



BHARAT HEAVY ELECTRICALS LIMITED
HEEP HARIDWAR INDIA-PIN 249403
FAX NO: 0091 1334 226462
PHONE NO: 0091 1334 284142

Enq. No.: **T/T212/2016/0388N1**

Date of issue : 17/05/2016

M/S.....

Sub: BHEL-HEEP/OPEN-TENDER (C&F)/2016

Dear Sir,

The Heavy Electricals Equipment Plant (HEEP) located in Haridwar, India is one of the major manufacturing plants of Bharat Heavy Electricals Ltd. The core business of HEEP includes design and manufacture of large steam and gas turbines, turbo generators and so on.

Sealed tenders with the Tender No. and opening date clearly super scribed on the cover are invited from the manufacturers (registered as well as unregistered) for the supply of the following items:-

S. No.	Tender No.	Description of Item	Delivery required	Qty. (Nos)
1	T/T212/2016/0388N1	W95310530029	30.09.16	4
		DRG: 41053056999 REV: 01	30.11.16	2
		FORGING FOR SEAL RING	31.03.17	2
		MATERIAL:NICR20TIAL	31.07.17	2
		SPEC: HW19391 REV: 2		

The details with required delivery are given in **Annexure-2**.

The tender documents can be downloaded from our web site www.bhel.com or www.bhelhwr.co.in or www.tenders.gov.in, after downloading the tender documents from web site, while submitting the tender as detailed in "Instruction to Bidders", intending vendors must remit tender fee of Rs. 2,000.00 for indigenous vendors (or equivalent amount in foreign currency for foreign vendors) against each tender if documents (in hard copies) are required from BHEL. Vendors must also remit the requisite EMD Rs 40,000/- (Rupees forty thousand) in the form of Cash (as permissible under Income Tax Act) / Pay Order / Demand draft. **If EMD is not submitted along with offer, then the offer may be out rightly rejected.** As per notification reference no. NSIC/HO/GP/15(4)/2013-14 dated 07.07.2013 Micro & Small Enterprises (MSEs) are not required to submit EMD & tender fees. A certificate issued from competent authority shall be submitted in support of Micro & Small Enterprises (MSEs). BHEL will not be responsible for any type of postal delay / incomplete information from vendor.

Central / State – PSUs / Government departments are exempted from submission of EMD subject to approval by BHEL management.

PMD vendors registered with HEEP, Haridwar for above mentioned material code vide vendor code M23019, M79037, S09897, S70061 are exempted from submitting of EMD.

The date for opening of tender shall be 08.06.2016. Tenders will be received up to 1.45 P.M. on **08.06.2016** and opened on the same day at 2.00 P.M. in the Tender Room. **Please note that tender received after due date & time (1.45 PM on 08.06.2016) will not be REPEAT will not be opened.** BHEL will not be responsible for any type of postal / courier delay.

Specifications & Drawing of the above items are available on our above mentioned website. Other cross referred documents can either be physically collected from BHEL, Haridwar or can be obtained by email sachin_m@bhelhwr.co.in, r_kumar@bhelhwr.co.in or jainv@bhelhwr.co.in against proof of draft of the tender fee in favor of BHEL, Haridwar. This draft is to be submitted along with offer. Amendments/Corrigendum, if any, will be hosted on our web site only. Other terms and conditions will be as per tender documents.

The total quantity may undergo change at the time of ordering.

Any vendor who is under hold (for the item)/ delisted/ banned with BHEL on the date of opening of Part – 1 should not quote for this tender. In case their offer is received, it may be out rightly rejected.

Documents submitted with the offer/bid by the bidder (original registered supplier) shall be *signed and stamped* in each page by authorized representative of the bidder. Documents *not signed and stamped* in each page by the authorized signatory of the bidder, shall not be accepted and considered for evaluation of the bid.

Please submit your Techno-Commercial offer only for the above requirement subject to our terms and conditions.

BIDS shall be opened at 2 PM on the due date in the presence of authorized representative of the bidders who may like to be present. The authorized representative should bring authority letter from their parent company (Manufacturer) for the specific tender no. attending the bid opening.

BHEL will forfeit the EMD if, the successful bidder / vendor refuses to honor the order after award of the same on him and / or withdraws his bid and / or unilaterally changes the offer and / or any of its terms & conditions within the validity period.

KINDLY READ “INSTRUCTIONS TO BIDDERS.” QUOTATION NOT IN ACCORDANCE WITH THE INSTRUCTIONS ARE LIABLE TO BE DISQUALIFIED AND IGNORED.

INSTRUCTIONS TO BIDDERS FOR OPEN TENDER

1.0 DEFINITION

Registered Vendors - Are those who are registered with BHEL, Haridwar for Megawatt rating/ Size/ Weight of tendered components in respective steel grade or machining of such components.

Un-registered Vendors - Are those who are not registered with BHEL, Haridwar for Megawatt rating/ Size/ Weight of tendered components in respective steel grade or machining of such components.

2.0 TECHNICAL QUALIFICATION

- Enclosed format – Annexure-3 to be submitted. It is a mandatory requirement. Offer of Vendors not meeting these requirements may not be considered.

3.0 ESSENTIAL INSTRUCTIONS

1. All un-registered vendors shall be approved by BHEL, if found suitable, on the basis of data furnished by them in Supplier Registration Form (SRF) Foreign Vendors or Indigenous Vendors. Vendor (s) shall not be considered for ordering if not approved by BHEL.
2. BHEL team may visit the vendor (s) works for verification of capability and capacity claimed in tender documents/offer (s).
3. The tenders shall be submitted in three parts as described below on or before the due date. Vendor Registration Form shall be submitted by unregistered vendors only.

i. Part I (Envelop I) – A. EMD & Tender Fee

or

Valid certificate towards exemption of EMD & tender fee, applicable for Micro and small Enterprises, as mentioned below:

MSE Suppliers can avail the intended benefits only if they submit along with the offer, attested copies of either EM II certificate having deemed validity (five years from the date of issue of acknowledgement in EM II) or valid NSIC certificate or EM II certificate along with attested copy of a CA certificate (format {Annexure-1} enclosed where deemed validity of EM II certificate of five years has expired) applicable for the relevant financial year (latest audited). Date to be reckoned for determining the deemed validity will be the date of bid opening (Part I in case of three part bid). Non submission of such documents will lead to disqualification of their offer. Documents should be notarized or attested by a Gazetted Officer.

B. Pre-Qualifying Requirement (PQR) – refer Annexure – 3.

C. Vendor Registration Form (SRF documents to be placed separately in part-I and not to be mixed with other documents).

ii. Part II (Envelop II) - Techno -Commercial Bid

iii. Part III (Envelop III) - Price Bid

4. The Quotation should be from the Principal / Original Manufacturer, failing which the quotation is likely to be ignored. However, if OEM / Principal insist on engaging the services of an agent, such agent shall not be allowed to represent more than one manufacturer / supplier in the same tender. Moreover, either the agent could bid on behalf of the manufacturer / supplier or the manufacturer / supplier could bid directly but not both. In case bids are received from both, the manufacturer / supplier and the agent, bid received from the agent shall be ignored. In Case the quotation is submitted through agent, the quotation must accompany original authorization letter from the Principal / Original Manufacturer.
5. The bidders will have to submit signed & stamped offer on each page / bid in original directly to BHEL. **Unsigned bids shall be ignored.**
6. The suppliers or their authorized person may be allowed to attend the tender opening, if duly authorized by their principals, through a specific letter for a particular enquiry or for specific price bid opening on that particular day. General authorization letter is not acceptable

7. Any corrections / amendments shall be properly & fully authenticated with signature. No overwriting is acceptable.
8. Compliance of technical/ commercial terms and conditions as per Annexure-4
9. Part-I will be opened on the date and time specified in the tender notice in the presence of those vendors who wish to attend.
10. Part-II bid will be opened of the vendors who successfully qualify the PQR requirements and have submitted tender fees & EMD or valid certificate towards exemption of EMD & tender fee, applicable for Micro and small Enterprises.
11. Part – III (Price Bids) along with supplementary price bids, if necessary, will be opened at a later date of only those bidders whose techno-commercial bid has been found acceptable.
12. Vendor to quote best possible deliveries in the offer. Offers of those vendors may not be considered if it is not found suitable to BHEL requirement.
13. Currency exchange rate will be applicable on the date of opening of Part-I for evaluation purpose.
14. Depending upon the delivery suitability, BHEL reserves the right to split order on more than one vendor.
15. Evaluation of Bid: - The bid shall be evaluated
 - a. Cost to BHEL basis. (Basic Cost + Insurance + Transportation + Duty)
 - b. The loading, if any, on account of LD penalty, payment terms or any other cost determined at later stage, which shall be communicated to the vendor.
16. Tenders when finalized shall be in the name of the bidder only and change of name during tender evaluation (without certificate from registrar of company) and after submission of the tender is liable to make the offer ineligible for participation.
17. All test certificates / Guarantee certificates to be submitted in TRIPLICATE along with dispatch documents.
18. BHEL reserves the right to open the price bid (part-III) along with the opening of techno-commercial offer at its option and in that case vendor will be informed accordingly.
19. BHEL reserves the right to go for reverse auction. Vendors are requested to give their best price. In case of failure of reverse auction the paper bid shall be processed. Bidder should clearly indicate their acceptance for reverse auctioning in Annexure-3. The bids of those vendors who do not agree for reverse auction may not be considered. The Terms & Condition for Reverse Auctioning are given below.
20. Total weight -- /Gross / Net in Kg. & also package size essentially should be indicated if not exact then approximate.
21. BHEL will evaluate the technical bids against essential criteria/requirements. BHEL may seek clarifications, if required, from the qualified bidders only. These clarifications will be communicated to the eligible vendors. The offers of those bidders, who are unable to respond in specified time frame, are likely to be ignored.
22. SETTLEMENT OF DISPUTES
 - Indigenous Vendors: In all cases of dispute the matter shall be referred for arbitration to any arbitrator to be appointed by the Executive Director or any officer who is the administrative head of Bharat Heavy Electricals Ltd., at Haridwar. The venue of arbitration shall invariably be Ranipur Haridwar. The award of the arbitrator shall be final and binding on both the parties. The arbitrator shall have the power to extend, from time to time, the time for making his award with the consent of the parties.
 - Foreign Vendors: In the event of any dispute or difference arising between the parties to this contract regarding execution of same or their respective rights and liabilities there under, the same shall except as otherwise expressly provided therein, be referred to the arbitration of the two arbitrators, one to be appointed by each party; or in the case of the said arbitrators not agreeing then an umpire to be appointed by the two arbitrators in writing before entering on that reference and provisions of the Indian Arbitration Act ,1940 or any statutory notification, or re-enactment therefore and rules framed there under from time to time shall apply to such arbitration . If the two arbitrators do not agree on the appointment of umpire, the nomination of the umpire shall be done by the International Chamber of Commerce, Paris(France).The decision of arbitrators, or in case of their not agreeing, that of the said umpire shall be binding both on seller and purchaser. The venue of the arbitration invariably be New Delhi.
23. JURISDICTION

All question, dispute or differences arising under, out of or in connection with the purchase order shall be subject to the exclusive jurisdiction of Haridwar courts.
24. OVER RIDING CLAUSE

All stipulations made in any correspondence other than those exchanged in regards to “instruction” in our tender documents / enquiry for submission of your offer, if at all shall be void to the extent they are repugnant to the conditions contained herein above and in the purchase order.
25. FINALITY OF MANAGEMENT DECISION

At all places in the preceding clauses BHEL Management’s decision shall be final.

26.GENERAL INSTRUCTIONS AND STANDARD TERMS & CONDITIONS (GISTC)

Please visit our site www.bhelhwr.co.in for General Instructions and Standard Terms & Conditions (GISTC) for Tender Enquiries. All the bidders/vendors must ensure compliance of these GISTC.

4.0 INSTRUCTIONS

PART-I (EMD & tender fees (or exemption certificate), PQR and SRF in envelope - I) shall comprise of following documents:

- a. Annexure-3 for Pre-qualification requirement. Point wise reply to all the points mentioned in Pre-Qualifying Requirement specified in the tender. Relevant documents as requested in Pre-Qualifying Requirement must be attached.
- b. Vendor Registration Form (SRF)
(Kindly follow the link and follow instructions: <http://supplier.bhel.in/>)
The SRF duly filled up will be assessed for manufacturing capability quality systems being followed, organizational soundness and financial worthiness. The same shall be submitted with Part-I by un-registered vendor only with BHEL, HEEL, Haridwar or the proof of submission through online portal. BHEL registered vendors (registered with permanent code M, N, S) need not to submit SRF.
For vendors registered with T code, SRF is to be submitted essentially along with the offer.
- c. Non-disclosure agreement as per Annexure 5. The agreement shall be duly stamped & signed.

PART-II (Technical clarification in envelope - II) shall comprise of following documents:

- a. Complete technical offer.
- b. Annexure-4 for compliance of technical/ commercial terms and conditions.
- c. Complete technical offer as per specification, drawings, technical requirement along with un-priced bid indicating C&F rate, separate Lloyd's/BV/TUV inspection charges (for Foreign vendors) and delivery schedule.
- d. Validity of offer to be indicated.
- e. Deviation with reference to specification/drawing, if any, should be clearly indicated on a separate sheet.
- f. Copy of price Bid (without prices).
- g. Vendor to send submit QP in the enclosed format (Annexure-6) for BHEL approval. Final inspection shall be by Third party inspection agency (LRS/TUV/BV) for foreign suppliers and by BHEL nominated inspection agency "TUV" for indigenous suppliers as per finally BHEL approved QP.
- h. Any additional documents.

PART -III (Price Bid)

- a. Price bid with prices to be submitted as part-III of the tender.
- b. If price bid is not submitted along with Part-I bid, the offer will be rejected out rightly.
- c. In case of foreign vendors, prices to be quoted on C&F Mumbai seaport basis. However, for air shipment the rates to be quoted on CPT Mumbai port basis. And air freight charges to be indicated separately in price bid. Further non-availability of flight/ship will not be accepted for rescheduling the delivery or waiver of penalties on account of delayed delivery.
- d. In case of Indigenous vendor, prices must be quoted on FOR-Destination-CPS-HEEL-BHEL basis. However, the insurance will be arranged by BHEL. Vendor can dispatch good through any BHEL/Indian Bank Association approved transporters having their branch at Haridwar / destination. For the convenience name and address of transporters approved by IBA and BHEL are posted at website www.bhelhwr.co.in. Further, non-availability of BHEL/ Indian Bank Association approved transporter will not be accepted for rescheduling of delivery or waiver of penalties.
- e. In case of foreign vendors, third party (Lloyd's/BV/TUV) inspection charges to be quoted separately as third party inspection (Lloyd's/BV/TUV) is in vendor's scope. For Indian vendors, inspection shall be by TUV/ BHEL nominated inspection agency. Prices shall be loaded by 0.2%

on account of TUV/ BHEL nominated inspection agency inspection charges. Third Party inspection shall be in BHEL scope.

- f. Prices should remain firm till the execution of the order. However, in case vendor prefers to maintain their own PVC formula, they can do so. Vendors must give upper & lower cap. However, lower cap has to be either equal or more in percentage point than the upper cap from base prices. This is **must** for evaluation purpose. **Upper price limit** will be considered for evaluation purpose.
- g. Insurance during transportation shall be taken care of by BHEL.
- h. Applicable sales Tax, Excise duty, service tax, educational cess and any other statutory levy should be indicated separately and clearly in the quotation.
- i. **Prices are to be written in both Figures & Words. In case of any difference between the two, If there is a discrepancy between words and figures, the amount in words shall prevail for evaluation and establishing L1 status.**
- j. **LD Penalty shall be applicable at the rate of 0.5% of the total order value per week of delay or part thereof subject to a maximum of 10% of the total order value. In case of any variation in LD penalty acceptance, your prices shall be loaded to the extent LD penalty not accepted by you.**
- k. Payment term shall be "100% payment against dispatch documents, through irrevocable LC (for foreign vendors) with bank charges as either side' and 100% after receipt and acceptance of material (for indigenous vendors)". **BHEL as a rule do not agree to release advance payment.**
- l. Irrevocable LC is opened for one quarter (3 months) & is established 30 days prior to delivery schedule. The charges of establishing the LC are on either side i.e. charges in India to be borne by BHEL and charges outside of India to be borne by vendor. If any vendor insists for LC for more than one quarter, vendor has to essentially bear all charges (Within & Outside India) for the period exceeding one quarter.
- m. **BHEL does not open confirmed LC even if vendor agrees to bear the confirmation charges.**
- n. **The comparison between foreign and indigenous bids shall be done based on the Total Landed cost at Destination basis.**

Note:

After tender opening (Part-I), if it is found that:

- The bidder has not submitted the requisite Tender Fee and EMD (If applicable)
- The bidder has claimed to be an MSE vendor but no supporting documents have been submitted in this regard.

In both the above cases the offer of the bidder may be rejected and no correspondence from the bidder in this regard shall be entertained.

However, offer of the bidder shall be treated as per the guideline in case the bidder has claimed to be an MSE vendor and submitted requisite MSE documents.

BHEL reserves the rights to place order for tendered quantity on more than one vendor

Superscription on envelopes:

The following shall be superscribed on the envelopes:

PART-I

1. TENDER NO. AND ITEMS DESCRIPTION
2. DUE DATE FOR OPENING.
3. TENDER FEE, EMD (IF APPLICABLE) OR MSE CERTIFICATE TOWARDS EXEMPTION OF EMD & TENDER FEE
4. PRE- QUALIFYING REQUIREMENT (PQR)
5. SUPPLIER REGISTRATION FORM (SRF)
6. NON-DISCLOSURE AGREEMENT (NDA)

PART-II

1. TENDER NO. AND ITEMS DESCRIPTION
2. DUE DATE FOR OPENING OF PART-I.
3. TECHNO-COMMERCIAL BID

PART-III

1. TENDER NO. AND ITEMS DESCRIPTION
2. DUE DATE FOR OPENING OF PART-I
3. PRICE BID

The part-I, part-II & part-III shall be individually sealed and super scribed as indicated above and shall be enclosed further in the envelop duly sealed and super scribed as :

“TENDER FOR (ITEM NAME) AGAINST TENDER NO.----- DUE ON -----
-----CONTAINING PART-I, PART-II & PART-III OF THIS OFFER.” Vendor’s full name and address should be clearly mentioned on the envelope and shall be addressed to:

To,
Head of Materials Management,
Heavy Electrical Equipment Plant,
BHEL,
Hardwar- 249403

Envelopes not marked as above are liable to be ignored and will not be opened.

IN CASE YOU ARE NOT MAKING AN OFFER AGAINST THIS ENQUIRY, THEN PLEASE ARRANGE TO SEND A LETTER OF REGRET IF YOU HAVE COLLECTED THE TENDER DOCUMENTS FROM BHEL.

TERMS AND CONDITIONS OF REVERSE AUCTIONING

Against this enquiry for the subject item /system with detailed scope of supply as per enquiry specifications, BHEL may resort to “REVERSE AUCTION PROCEDURE” i.e., ON LINE BIDDING ON INTERNET.

- For the proposed reverse auction, technically and commercially acceptable bidders only shall be eligible to participate.
- BHEL will engage the services of a service provider who will provide all necessary training and assistance before commencement of on-line bidding on internet.
- BHEL will inform the vendor in writing in case of reverse auction, the details of Service Provider to enable them to contact & get trained.
- Business rules like event date, time, start price, bid decrement, extensions etc. also will be communicated through service provider for compliance.
- Vendors have to fax the Compliance form in the prescribed format (provided by Service provider) before start of Reverse auction. Without this, the vendor will not be eligible to participate in the event.
- BHEL will provide the calculation sheet (e.g., EXCEL sheet) which will help to arrive at “Total Cost to BHEL” like Packing & forwarding charges, Taxes and Duties, Freight charges, Insurance, Service Tax for Services and loading factors (for non-compliance to BHEL standard Commercial terms & conditions) for each of the vendor to enable them to fill-in the price and keep it ready for keying in during the Auction.
- Reverse auction will be conducted on scheduled date & time.
- At the end of Reverse Auction event, the lowest bidder value will be known on the network.
- The lowest bidder has to Fax the duly signed Filled-in prescribed format as provided on case-to-case basis to BHEL through Service provider within 24 hours of Auction without fail.
- Any variation between the on-line bid value and the signed document will be considered as sabotaging the tender process and will invite disqualification of vendor to conduct business with BHEL as per prevailing procedure.
- In case BHEL decides not to go for Reverse Auction procedure for this tender enquiry, the Price bids and price impacts, if any, already submitted and available with BHEL shall be opened as per BHEL’s standard practice.
- In case BHEL decides to go for reverse auction, the H1 bidder (whose quote is highest in online sealed bid) may not be allowed to participate in further RA process.

Certificate by Chartered Accountant on letter head

This is to Certify that M/S
(hereinafter referred to as 'company') having its registered office at
..... is registered under MSMED Act 2006, (Entrepreneur
Memorandum No (Part-II) dtd:.....,
Category: (Micro/Small)). (Copy enclosed).

Further verified from the Books of Accounts that the investment of the company as on
date..... as per MSMED Act 2006 is as follows:

1. **For Manufacturing Enterprises:** Investment in plant and machinery (i.e. original cost excluding land and building and the items specified by the Ministry of Small Scale Industries vide its notification No.S.O.1722(E) dated October 5, 2006 :
Rs.....Lacs
2. **For Service Enterprises:** Investment in equipment (original cost excluding land and building and furniture, fittings and other items not directly related to the service rendered or as may be notified under the MSMED Act, 2006:
Rs.....Lacs

The above investment of Rs.....Lacs is within permissible limit of
Rs.....Lacs forMicro / Small (Strike off which is not applicable)
Category under MSMED Act 2006.

Date:

(Signature)

Name -

Membership number -

Seal of Chartered Accountant



Annexure- 2

S. No.	Tender No.	Description of Item	Delivery required	Qty (Nos)
1	T/T212/2016/0388N/1	W95310530029 DRG: 41053056999 REV: 01 FORGING FOR SEAL RING MATERIAL:NICR20TIAL SPEC: HW19391 REV: 2	30.09.16 30.11.16 31.03.17 31.07.17	4 2 2 2

Minimum qualification requirement for Forging for INDENT NO.: T/212/16/0388/N

Following are the mandatory requirements. Offers of vendors not meeting these requirements will not be considered.

- 1. Vendor must have manufactured and supplied at least 3 ring forgings in material grade NiCr20TiAl (material number 2.4952) in last three years.
In support of above, the vendor has to furnish details of supply of last 3 rings in the format below:

Sl. No	Purchase Order No	Customer Name and Address	Quantity	Year of Supply

Vendor to submit documents like purchase order/test certificates/dispatch certificate issued by third party like TUV/Lloyd/BV etc for above referred three rings in support of their experience of successfully manufacturing and supplying forgings of material grade NiCr20TiAl (material number 2.4952).

- 2. (a) Vendor must have in-house forging and heat treatment facility to manufacture forgings of material grade NiCr20TiAl of enquiry drawing dimensions. Details of in-house manufacturing facilities covering forging and heat treatment are to be submitted with offer.
- (b) Raw material NiCr20TiAl for forging shall be manufactured by **vacuum induction melting and subsequently electro slag refined or vacuum arc re-melted**. Vendor is to submit their in house melting and refining facility to manufacture raw material.
In case in house facility for raw material manufacturing is not available, vendor to submit their source for raw material. Details of raw material source provider covering their melting and refining facility and at least one mill test certificate in support of experience of raw material manufacturer to be submitted.
- (c) Details of in-house testing facilities are to be submitted with offer. In case of outsourcing of any test, vendor to agree to carry out testing at Government accredited labs only.

ANNEXURE- 4

COMPLIANCE SHEET FOR TECHNICAL/COMMERCIAL TERMS AND CONDITIONS FOR THREE PART TENDER

PLEASE FILL THIS ANNEXURE & ATTACH WITH YOUR TECHNO-COMMERCIAL BID.

You are requested to kindly confirm /clarify the following:-

S.No.	Description	Your Confirmation
1.	Vendor to confirm that they meet each & every clause of our Specifications/Drawings.	
2.	If “No” to serial number 1, vendor to specify each deviated clause & submit in a separate sheet.	
3.	Vendor to list out on a separate sheet any activity which is outsourced. Please furnish details of out sourced vendor.	
4.	Validity: confirm that validity of the offer shall be 90 days from the date of tender opening	
5.	Confirm that un-priced part of price bid is enclosed with technical commercial offer.	
6.	Confirm that prices have been quoted on C & F Mumbai Port basis (For Foreign vendors)	
7.	Confirm that Loading Port has been mentioned (For Foreign vendors).	
8.	Confirm that prices have been quoted on FOR BHEL Haridwar basis. (For Indigenous vendor)	
9.	Confirm that prices shall be firm and fixed throughout delivery period.	
10.	Confirm that preferably payment term shall be “100% payment after receipt and acceptance of material”.	
11.	LD Penalty shall be applicable at the rate of @ 0.5% of the total order value per week of delay or part thereof subject to a maximum of 10% of the total order value shall be applicable. In case of any variation in LD penalty, your prices shall be loaded to the extent LD penalty not accepted by you.	
12.	Confirm that all test certificates / Guarantee certificates to be submitted as per BHEL specification. in TRIPLICATE along with dispatch documents	
13.	Right of acceptance – BHEL reserves the right to reject any or all quotations without assigning any reasons thereof. BHEL also reserves the right to increase or decrease the tendered quantities. Vendors should be prepared to accept order for reduced quantities without any extra charges. Vendor should also be prepared for giving discount in case of increase in quantity.	
14.	Confirm specifically that material shall be supplied as per tender documents.	
15.	No grace period in delivery is acceptable. Please quote delivery accordingly.	
16.	Ink signed order acceptance shall be furnished within 15 days of order placement.	
17.	Confirm if there is Indian agency commission included in your price.	
18.	Please confirm your acceptance for Reverse Auctioning of these items.	
19.	In case of PO (if any), Invoices against goods and services have to be submitted immediately after supply of goods and services but not later than 30 days from the invoice date. In case of any delay, consequential losses like loss of input credit and non-availability of concessional forms etc., shall be to the vendor’s account (For Indigenous vendor)	
20.	Confirm that third party inspection charges (LRS/BV/TUV) quoted separately or mention that third party inspection charges are included in the quoted prices of the offer. If vendor do not quote third party inspection charges or not mention that third party inspection charges are included in quoted prices, then it shall be presumed that third party inspection charges are included in the quoted prices of the offer. No further clarification shall be asked in this regard after opening of techno-commercial bid.	

Annexure-5

NON-DISCLOSURE AND PROPRIETARY INFORMATION AGREEMENT

BETWEEN

_____ (**Name of the Vendor**),, having its register ed offices i n
_____ (**Address of Vendor**), registered under the no. _____
of the Companies' register of _____ (**Name of Place and Country**),
capital stock of _____ (**Value**), with a pl ace of business in
_____ (**Name of Place and Country**) (hereinafter referred to as
" _____ (**Name of Vendor**)");

AND

Bharat Heavy Electricals Ltd a company incorporated under the Indian Companies Act 1956 having its registered offices at BHEL House, Siri Fort, New Delhi -110 049 and having one of its works at Heavy Electrical Equipment Plant, Ranipur, Haridwar-249403 (Uttarakhand), India registered under the No. 4281 of 1964-65 of the companies register of Delhi, capital stock of Rs 4895.2 million with a place of registered office in New Delhi (hereinafter referred to as “BHEL”) hereinafter also referred to individually as “the Party” or collectively as “the Parties”.

BACKGROUND

This Agreement sets forth the rights and obligations of the Parties with respect to the use, handling, protection and safeguarding of Proprietary Information that is disclosed by and between the Parties.

WHEREAS

A) the Parties wish to pursue exploratory discussions concerning a possible collaboration between them in relation to the Program defined in Exhibit 1;

B) during the ensuing discussions and negotiations it may occur that either Party discloses to the other technical, financial or business information of a proprietary or confidential nature, which the Parties intend to protect against, making it available, by any means to any third person, and other unauthorized use and/or further disclosure by the recipient, in accordance with the terms and conditions set forth herein;

NOW, THEREFORE, the Parties have agreed as follows:

1. The term “Proprietary Information” shall mean any information or data of whatsoever kind of a confidential or proprietary nature, including but not limited to, commercial information, know how and technical information in the form of designs, drawings, concepts, requirements, specifications, software, interfaces, components, processes, or the like, that have been or will be disclosed by either Party to the other pursuant to this Agreement, either in writing, orally or other form, which is designated as “Proprietary” or “Confidential” by the disclosing Party by means of formal declaration or an appropriate stamp, legend or any other written or orally notice .
2. Proprietary Information may be conveyed, without limitation, through any written or printed documents, samples, models, electronic form on disk, tape, other storage media or any other means of disclosing such Proprietary Information that either Party may elect to use during the life of this Agreement, but if an originating Party originally discloses information orally or visually, the receiving Party will protect such information as Proprietary Information to the extent that the originating Party :
 - identifies the Information as Proprietary at the time of original disclosure,
 - summarizes the Proprietary Information in writing .

Information stored in electronic form on disk, tape, other storage media will be adequately marked if a proprietary legend displays when the information originally runs on a computer system and when the information is printed from its data file.

Proprietary Information also includes any information which can be obtained by examination, testing or analysis of any hardware or material substance or any component part of such hardware or material substance provided by the Disclosing Party even though the requirements in Clause 1 for marking and designation have not been fulfilled.

3. Each Party, to the extent of its rights to do so, shall disclose to the other only the Proprietary Information which the disclosing Party deems appropriate to fulfil the objectives of this Agreement. The Parties hereby represent that the disclosure of Proprietary Information by and between themselves shall be made in compliance with, and subject to the laws and regulations of the Disclosing Party's country.

4. The receiving Party hereby agrees and covenants that, from the effective date of this Agreement until the expiry date as per article 11 and the following period as per article 12, the Proprietary Information that either Party receives from the other shall:
 - a) be protected and kept in strict confidence by the receiving Party which must use the same degree of care it uses to protect its own confidential information and in no case less than a reasonable care;

 - b) be only disclosed to and used by those persons within the receiving Party's organization or that of its parent or controlled companies who have a need to know and solely for the purposes specified in this Agreement, and be treated by such persons or entities with the same degree of care and subject to the same restrictions;

 - c) to procure that each third party to whom Proprietary Information is disclosed under this Agreement is made aware of the provisions of this Agreement prior to such disclosure to it and that each such third party is

bound by obligations of confidentiality which are no less onerous than those contained in this Agreement;

- d) neither be disclosed nor caused to be disclosed or made available, either directly or indirectly, to any third Party or persons other than those mentioned in subparagraph b) above or other persons upon which both of the contractual Parties shall agree in an amendment to this Agreement;
- e) not to copy, reproduce or reduce to writing any part of such Proprietary Information except as may be reasonably necessary for the purpose referred to in the Recitals of this Agreement

PROVIDED THAT the Receiving Party shall be entitled to make any disclosure required by court order or government or regulatory requirement of the Disclosing Party's Proprietary Information subject to notifying the Disclosing Party as soon as possible of such requirement

- 5. Any Proprietary Information and copies thereof disclosed by either Party to the other shall remain the property of the disclosing Party and shall be immediately returned or destroyed by the receiving Party upon request.
- 6. The receiving Party shall have no obligations or restrictions with respect to any Proprietary Information for which the receiving Party can prove that:
 - a) is in or which comes into the public domain otherwise than as a result of a breach of this Agreement by any person to whom a disclosure of Proprietary Information is made as permitted under this Agreement or of any other duty of confidentiality relating to the Proprietary Information of which the Receiving Party has knowledge; or
 - b) it has been in its possession without restriction at the time of the disclosure, as evidenced by written documentation in its files; or
 - c) it has been lawfully received from a third Party without breach of this Agreement; or

- d) it has been or is published without violation of this Agreement; or
 - e) it has been independently developed in good faith by employees of the receiving Party who did not have access to the Proprietary Information; or
 - f) it has not been properly declared, designated or confirmed as Proprietary or Confidential; or
 - g) the protection period has expired according to articles 11 and 12 of this Agreement.
7. With respect to any exchange of Proprietary Information which may occur as a result of this Agreement, it is expressly understood and agreed that the persons listed in Exhibit 2 shall, on behalf of the respective Parties, be the exclusive individuals authorized to receive from and transmit to the other Party Proprietary Information under this Agreement. Each Party may replace at any time its respective authorized individuals identified in such Exhibit 2, within its own organization. Any such new designation by a Party shall be made by written notice to the other at the address indicated in such Exhibit 2.
8. Any Proprietary Information which is identified as "Classified Information", or whose export is subject to an export license, shall be identified as such by the disclosing Party at the time of disclosure and the disclosure, protection, use and handling thereof, shall remain subject to the security procedures and restrictions imposed by the disclosing Party's Government.
9. The disclosure of Proprietary Information under this Agreement by either Party to the other shall not be construed as granting to the receiving Party any right, whether express or implied by licence or otherwise, on the matters, inventions or discoveries to which such information pertains, or as granting any trademark, patents, copyrights, trade secret right or other form of intellectual property right.

10. Nothing in this Agreement may be construed as an obligation of either Party to disclose any Proprietary Information to the other, or to enter into any subsequent contractual relationship with such other Party.
11. This Agreement covers the exchange of Proprietary Information which may be made by either Party to the other until ten years from signing of the agreement or any extension thereto which may be agreed upon by the Parties in writing. Proprietary information relevant to the Program detailed in Exhibit 1, already made available to the other contractual Party before the effective date, shall also be protected under this Agreement.

It is understood by the parties that, prior to disclosure, the Disclosing Party shall have obtained any government authorisation needed for the export of the Proprietary Information

12. The expiry of the period contemplated in Article 11 of this Agreement shall not relieve the receiving Party from complying with the obligations imposed by Article 4 here above with respect to the use and protection of the Proprietary Information, received prior the date of such expiry, for a period of ten (10) years after such expiry.
13. The Parties are independent contractors. Each will bear all costs and expenses in connection with this Agreement. This Agreement is intended to facilitate only the exchange of Proprietary Information and is not intended to be, and shall not be construed to create a teaming agreement, joint venture, association, partnership, or other business organisation or a agency arrangement and no Party shall have the authority to bind the other without the other Party's separate prior written agreement.
14. This Agreement shall be governed by and shall be interpreted in accordance with the substantive federal laws of Switzerland excluding its choice of law rules.

Irrespective of the foregoing each Party shall remain bound by the provisions of its own national laws and regulations with respect to the transfer or use of Classified Information or information whose export is subject to an export license.

15. All disputes among the Parties, in connection with or arising out of the existence, validity, construction, performance and termination of this Agreement (or any terms thereof), which the Parties are unable to resolve among themselves, shall be finally settled by an Arbitration. The Arbitration shall be held in Geneva (CH) in English language, in accordance with the rules of the ICC – International Chamber of Commerce by three arbitrators appointed in accordance with said rules.
16. The foregoing constitutes the entire Agreement among the Parties with respect to the subject matter hereof and supersedes and cancels all prior representations, negotiations, commitments, undertakings, communications, either oral or written, acceptances, understandings and agreements among the Parties with respect to or in connection with any of the matters to which such Agreement applies or refers.
17. Notices to _____ (**Name of Vendor**) shall be made at the following address:

(Complete Address of Vendor)

Attention: Mr. _____ (**Name of the Authorised Person of Vendor**)

Notices to BHEL shall be made at the following address:

BHARAT HEAVY ELECTRICALS LIMITED,

HEAVY ELECTRICAL EQUIPMENT PLANT,

Ranipur, Haridwar-249403 (Uttarakhand), India

Attention: Shri B.M.Bansal, General Manager- Materials Management

18. The effective date of this Agreement shall be the date of the last signature appearing herein.

IN WITNESS WHEREOF, each of the Parties has caused this Agreement, to be executed by its duly authorized officer.

Date :

Signed for and on behalf of

Signed for and on behalf of

(Name of Vendor)

BHEL

By:

By:

Title:

Title:

Signature:

Signature:

EXHIBIT 1

to the

NON-DISCLOSURE AGREEMENT

between

_____ **(Name of Vendor)**

and

BHARAT HEAVY ELECTRICALS LIMITED

dated:

The Non Disclosure Agreement covers the exchange of Proprietary Information which may occur during the discussions and negotiations in view of a possible cooperation between the Parties in the following programs:

-Description of Material or Services for which the order is placed

_____ **(Name of Vendor)** list of products that require an exchange of Proprietary Information which may occur during the discussions and negotiations in view of a possible cooperation for the above programs :

EXHIBIT 2

to the

NON-DISCLOSURE AGREEMENT

between

_____ **(Name of Vendor)**

and

Bharat Heavy Electricals Ltd.

dated:

Personnel of the Parties authorized to receive and/or transmit Proprietary Information under this Agreement:

For **(Name of Vendor)**

(Name of Person)

Tel.

Fax

Address.

(Name of Person)

Tel.

Fax

Address.

For Bharat Heavy Electricals Ltd.

(Name of Person)

Tel.

Fax

Address.

(Name of Person)

Tel.

Fax

Address.

ANNEXURE-6

MANUFACTURER'S NAME AND ADDRESS		STANDARD QUALITY PLAN					TO BE FILLED BY BHEL		TO BE FILLED BY BHEL			
BHEL	VENDOR'S NAME	ITEM			QP NO.							
					REV							
		DRG. NO.	AS PER PO									
		SPEC.	AS PER PO									
	REV			Page 1 of 1								
SL. NO.	COMPONENT & OPERATIONS	CHARACTERISTICS	CLASS	TYPE OF CHECK	QUANTUM OF CHECK	REFERENCE DOCUMENT	ACCEPTANCE NORMS	FORMAT OF RECORDS	AGENCY			REMARKS
1	2	3	4	5	6	7	8	9	D	10	11	

MANUFACTURER/SUBCONTRACTOR	LEGEND:	FOR CUSTOMER USE	APPROVED BY
	! RECORDS IDENTIFIED WITH 'TICK' SHALL BE ESSENTIALLY INCLUDED BY CONTRACTOR IN QA DOCUMENTATION. M: MANUFACTURER / SUBCONTRACTOR B: BHEL / NOM. INSPECTION AGENCY N: CUSTOMER INDICATE 'P' PERFORM 'W' WITNESS AND 'V' VERIFICATION ALL 'W' INDICATED IN COLUMN 'N' SHALL BE 'CHP' OF CUSTOMER		

FIRST ANGLE PROJECTION (ALL DIMENSIONS ARE IN mm) FORM DG 39(B)

REV	DATE	ALTERED	REV	DATE	ALTERED RAJPAL sd/-	GMS No./ C.B.O.M.- NO.		STATUS OF DRG U		
		CHECKED	01	16.03.12	CHECKED ASHISH sd/-	01053056000				
ZONE			ZONE	SUPERSEDES THE OLD DRG. UNDER THE SAME NO. C/A. NO. MTE-12-F0013			AGREED DEPT	NAME	SIGN	DATE
							STE	DINESH	-Sd-	06.12.11
							TTX	SURENDRA	-Sd-	14.12.11
GRADE OF UNTOL.DIM			M/CG. ϕ /M/ \bar{A} -AA0230208			WELDING $\sqrt{B/\phi/D}$ AA0621104		GAS CUTTING-T3 AA0621101		

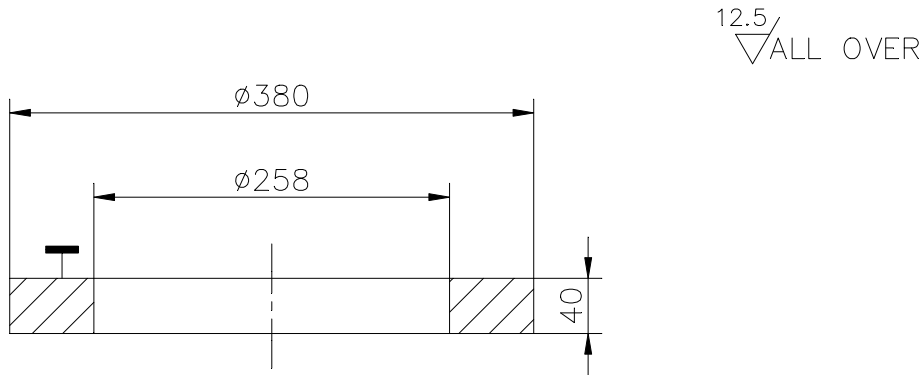

TECHNICAL REQUIREMENTS: -

1. FORGING SHALL BE SUPPLIED IN CONFORMITY WITH THE PURCHASE SPECIFICATION NO. HW19391.
2. TOLERANCE ON OUT SIDE DIMENSIONS +1 MM.
IN SIDE DIMENSIONS -1 MM.
3. THE SUPPLIER SHALL LOCATE THE POSITION OF TEST SAMPLE AND GET IT APPROVED FROM BHEL. PART OF TEST SAMPLE SHALL BE LEFT INTEGRAL FOR BHEL.
4. IDENTIFICATION MARKING SHALL BE DONE AT THE PLACE MARKED WITH ██████.

COPYRIGHT AND CONFIDENTIAL

THE INFORMATION ON THIS DOCUMENT IS THE PROPERTY OF BHARAT HEAVY ELECTRICALS LIMITED. IT MUST NOT BE USED DIRECTLY OR INDIRECTLY IN ANY WAY DETRIMENTAL TO THE INTEREST OF THE COMPANY.

Ref. Drawing No.	21053056007		FORGING FOR SEALING RING (R/M)		4-10530-56999		W95310530029		19 10	
			DESCRIPTION		DRAWING NO.		MATERIALCODE		UNIT WT.	
Sign & Date	STD		VAR		MATERIALSPEC		A		C	
	BHARAT HEAVY ELECTRICALS LTD. RANIPUR, HARDWAR		DRN		NAME		SIGN		DATE	
Inventory No.	DEPT MTE		SCALE		WEIGHT (KG)		REF. TO ASSY. DRG.		ITEM NO.	
	CODE 4300		1: 5		19.10		-		NO. OF ITEMS	
TITLE : FORGING FOR SEALING RING (ROUGH MACHINED)			CARD CODE		DRAWING NO.		4-10530-56999		22 23 24	
					SHEET No. 01		No. OF SHEETS		01	

दिनांक एवं हस्ताक्षर SIGN & DATE		संस्थान क्रय विनिर्देश (हीप - हरिद्वार) PLANT PURCHASE SPECIFICATION (HEEP - HARIDWAR)		HW 19391 पृष्ठ का Page 1 of 3	
		SUPERSEDES INVENTORY NO TLV 9520/04 Dec'08	<p align="center">ALLOY STEEL FORGINGS FOR HIGH TEMPERATURE SERVICE- +AT+P (Gr : NiCr20TiAl (Nimonic 80A))</p> <p>1.0 GENERAL: This specification governs the quality requirements of Alloy Steel Forgings or rolling for High temperature Service (Gr: NiCr20TiAl; material no. 2.4952) in precipitation hardened condition.</p> <p>2.0 APPLICATION: Used for turbine components such as Sealing ring $D \leq 2000$ mm.</p> <p>3.0 CONDITION OF DELIVERY: Solution annealed, stabilized and precipitation hardened. Unless otherwise specified in BHEL order / drawing, rough machining shall be carried out.</p> <p>4.0 DIMENSION AND TOLERANCES: Component shall be supplied to the dimensions and tolerances as per the ordering drawing.</p> <p>5.0 MANUFACTURING: Forgings shall be manufactured from steel produced by vacuum induction melting / electro-slag re-melting (VIM/ESR) or by vacuum induction melting / vacuum arc re-melting (VIM/VAR) process. The hot working shall be done in such a way that a uniform fine grained microstructure is achieved. Note: Raw material like Ingots/Blooms/Billets required for forgings shall be procured from BHEL approved sources along with test certificate."</p> <p>6.0 HEAT TREATMENT: The forging shall be heat treated as per EN 10269 to get the mechanical properties specified as per Clause 11.0. Solution annealing temperature shall be between $1050 - 1080^{\circ}\text{C}$ for 8 hours followed by air cooling. Stabilization treatment shall be carried out at $850 \pm 10^{\circ}\text{C}$ for 24 hours (air cooling) followed by precipitation hardening at $700 \pm 10^{\circ}\text{C}$ for 16 hours (air cooling).</p> <p>7.0 FINISH: As mentioned in the drawing.</p> <p>8.0 FREEDOM FROM DEFECTS The forgings shall be free from defects such as cracks, flakes, seams, segregation, non-metallic inclusions and other defects which may affect the utility of the forgings.</p>		
SUPERSEDES INVENTORY NO TLV 9520/04 Dec'08	<p align="center">ALLOY STEEL FORGINGS FOR HIGH TEMPERATURE SERVICE- +AT+P (Gr : NiCr20TiAl (Nimonic 80A))</p>				
COPYRIGHT AND CONFIDENTIAL The information on this document is the property of Bharat Heavy Electrical Limited. It must not be used directly or indirectly in any way detrimental to the interest of the company	<p>1.0 GENERAL: This specification governs the quality requirements of Alloy Steel Forgings or rolling for High temperature Service (Gr: NiCr20TiAl; material no. 2.4952) in precipitation hardened condition.</p> <p>2.0 APPLICATION: Used for turbine components such as Sealing ring $D \leq 2000$ mm.</p> <p>3.0 CONDITION OF DELIVERY: Solution annealed, stabilized and precipitation hardened. Unless otherwise specified in BHEL order / drawing, rough machining shall be carried out.</p> <p>4.0 DIMENSION AND TOLERANCES: Component shall be supplied to the dimensions and tolerances as per the ordering drawing.</p> <p>5.0 MANUFACTURING: Forgings shall be manufactured from steel produced by vacuum induction melting / electro-slag re-melting (VIM/ESR) or by vacuum induction melting / vacuum arc re-melting (VIM/VAR) process. The hot working shall be done in such a way that a uniform fine grained microstructure is achieved. Note: Raw material like Ingots/Blooms/Billets required for forgings shall be procured from BHEL approved sources along with test certificate."</p> <p>6.0 HEAT TREATMENT: The forging shall be heat treated as per EN 10269 to get the mechanical properties specified as per Clause 11.0. Solution annealing temperature shall be between $1050 - 1080^{\circ}\text{C}$ for 8 hours followed by air cooling. Stabilization treatment shall be carried out at $850 \pm 10^{\circ}\text{C}$ for 24 hours (air cooling) followed by precipitation hardening at $700 \pm 10^{\circ}\text{C}$ for 16 hours (air cooling).</p> <p>7.0 FINISH: As mentioned in the drawing.</p> <p>8.0 FREEDOM FROM DEFECTS The forgings shall be free from defects such as cracks, flakes, seams, segregation, non-metallic inclusions and other defects which may affect the utility of the forgings.</p>				
स्वत्वाधिकार एवं गोपनीय इस दस्तावेज में जो भी सूचना भारत हेवी इलेक्ट्रिकल्स की सम्पत्ति है, इसका प्रयोग एवं आरक्षण रूप से किसी भी तरह प्रयोग, जो कि कंपनी के हित में हानिकारक हो न किया जाए ।	<p>1.0 GENERAL: This specification governs the quality requirements of Alloy Steel Forgings or rolling for High temperature Service (Gr: NiCr20TiAl; material no. 2.4952) in precipitation hardened condition.</p> <p>2.0 APPLICATION: Used for turbine components such as Sealing ring $D \leq 2000$ mm.</p> <p>3.0 CONDITION OF DELIVERY: Solution annealed, stabilized and precipitation hardened. Unless otherwise specified in BHEL order / drawing, rough machining shall be carried out.</p> <p>4.0 DIMENSION AND TOLERANCES: Component shall be supplied to the dimensions and tolerances as per the ordering drawing.</p> <p>5.0 MANUFACTURING: Forgings shall be manufactured from steel produced by vacuum induction melting / electro-slag re-melting (VIM/ESR) or by vacuum induction melting / vacuum arc re-melting (VIM/VAR) process. The hot working shall be done in such a way that a uniform fine grained microstructure is achieved. Note: Raw material like Ingots/Blooms/Billets required for forgings shall be procured from BHEL approved sources along with test certificate."</p> <p>6.0 HEAT TREATMENT: The forging shall be heat treated as per EN 10269 to get the mechanical properties specified as per Clause 11.0. Solution annealing temperature shall be between $1050 - 1080^{\circ}\text{C}$ for 8 hours followed by air cooling. Stabilization treatment shall be carried out at $850 \pm 10^{\circ}\text{C}$ for 24 hours (air cooling) followed by precipitation hardening at $700 \pm 10^{\circ}\text{C}$ for 16 hours (air cooling).</p> <p>7.0 FINISH: As mentioned in the drawing.</p> <p>8.0 FREEDOM FROM DEFECTS The forgings shall be free from defects such as cracks, flakes, seams, segregation, non-metallic inclusions and other defects which may affect the utility of the forgings.</p>				
हस्ताक्षर एवं दिनांक SIGN & DATE 21/10/11	नाम NAME TSX	दिनांक एवं हस्ताक्षर SIGNATURE & DATE B. CHAUDHARY	अनुवादक TRANSLATED BY PSC	नाम NAME V. K. CHAUHAN	दिनांक एवं हस्ताक्षर SIGNATURE & DATE 21/10/11
सामग्री सूची संख्या INVENTORY NO Q-2007	सहमत विभाग AGREED DEPTT QAX	नाम NAME SUGANDH AGARWAL	जांचकर्ता CHECKED BY ASHISH RANJAN	पर्यवेक्षणकर्ता SUPERVISED BY GOPAL KRISHNAN	दिनांक एवं हस्ताक्षर SIGNATURE & DATE 21/10/11
स्वीकृति : संस्थान मानक समिति APPROVED : PLANT STANDARDS COMMITTEE		GP. NO 2.60		निर्माण : PREPARED : MTE	
जारी : मानक विभाग ISSUED : STANDARDS DIVISION		दिनांक : DATE : 23.11.1996		REV 02 SUPERSEDES 4.10.2011	

दिनांक एवं हस्ताक्षर SIGN & DATE		संस्थान क्रय विनिर्देश (हीप - हरिद्वार)	HW 19391
		PLANT PURCHASE SPECIFICATION (HEEP - HARIDWAR)	पृष्ठ का Page 2 of 3

सामग्री सूची संख्या को
INVENTORY NO

9.0 CHEMICAL COMPOSITION
Heat analysis in weight % shall be as per EN 10269 except for P, S and Ti+Al as follows:

C	0.04 - 0.10	Si	≤ 1.00	Mn	≤ 1.00
P	≤ 0.010	S	≤ 0.010	Al	1.00 - 1.80
B	≤ 0.008	Cr	18.00 - 21.00	Ni	≥ 65.00
Cu	≤ 0.20	Co	≤ 1.00	Ti	1.80 - 2.70
Fe	≤ 1.50	Ti+Al	≥ 3.50		

COPYRIGHT AND CONFIDENTIAL
The information on this document is the property of Bharat Heavy Electrical Limited. It must not be used directly or indirectly in any way detrimental to the interest of the company.

Following values shall be aimed at: Si ≤ 0.25; P ≤ 0.005; S ≤ 0.005

10.0 TEST SAMPLES:
A hardness test shall be performed on all rings at two diametrically opposite positions. At least three hardness indents per position are to be made.
The mechanical properties are to be determined at one forging per melt and heat treatment batch. The specimens are to be taken out of a test sample that has undergone an analogous forming process as the ring. The test sample shall be placed by the rings during the whole heat treatment.

11.0 MECHANICAL PROPERTIES:
The following properties shall be achieved in delivery condition at room temperature:

11.1 Tensile:
When tested as per IS: 1608, the test pieces after being heat treated as per Cl: 6.0 shall show the following properties. Following values are for information only. Actual values are to be taken from the standard.

0.2% Proof Strength (N/mm ²)	Tensile Strength (N/mm ²)	Elongation (l ₀ = 5d) (%)	Reduction In area (%)	Impact Energy (J) ¹	Hardness HB30
≥ 600	1000 - 1300	≥ 12	≥ 12	≥ 20	305 - 405

Average of 3 Charpy V-notch specimen

12.0 NONDESTRUCTIVE TESTING:
12.1 Following NDE shall be performed in delivery condition:
· Visual inspection
· Verification test
· 100% UT- inspection in simple shaped condition according to EN 10228-4 type 3b and 3c (table 2).
· 100% surface crack inspection in delivery condition according to EN 571-1 or to a similar procedure.
12.2 Criteria for registration and decision:
Regarding the UT- inspection quality class 3 (table 4) according to EN10228-4 shall be applied. The decision limit for loss of back wall echo is 3 dB and for the real reflector length 10mm.
Defects that will be cut during final machining shall be evaluated individually.
Surface crack inspection – All indications shall be recorded and evaluated individually.

13.0 RECTIFICATION OF DEFECTS:
Rectification of defects in forgings shall not be carried out by the supplier without the prior written permission of BHEL.



स्वत्वाधिकार एवं गोपनीय
इस प्रलेख में दी गई सूचना भारत हेवी इलेक्ट्रिकल्स की सम्पत्ति है इसका प्रयोग एवं आविष्कार रूप से किसी भी तरह प्रयोग, जो कि कंपनी के हित में हानिकारक हो न किया जाए।

दिनांक एवं हस्ताक्षर
SIGN & DATE

11/10/11

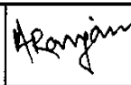
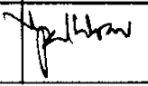
सामग्री सूची संख्या
INVENTORY NO

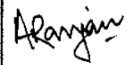
REV 02	निर्माणकर्ता WORKED BY	Ashish Ranjan		4.10.11
P-2007	जांचकर्ता CHECKED BY	Gopal Krishnan		4.10.11

दिनांक एवं हस्ताक्षर SIGN & DATE		<p align="center">संस्थान क्रय विनिर्देश (सीप - हरिद्वार)</p> <p align="center">PLANT PURCHASE SPECIFICATION</p> <p align="center">(HEEP - HARIDWAR)</p>	<p align="center">HW 19391</p> <p align="center">पृष्ठ का Page 3 of 3</p>
सामग्री सूची संख्या को SUPERSEDES INVENTORY NO. अधिकारित करना है	<p>14.0 TEST CERTIFICATES:</p> <p>Unless otherwise stated in the order, three copies of test certificates shall be supplied as per 3.1 of EN10204.</p> <p>In addition, the supplier shall ensure to enclose one copy of the test certificate along with their dispatch documents to facilitate quick clearance of the material.</p> <p>The following details shall be furnished in the test certificate:</p> <p>HW19391 : Alloy steel forgings for high temperature service+AT+P, NiCr20TiAl</p> <p>BHEL order</p> <p>Heat No. , and melting type.</p> <p>Dimensional inspection</p> <p>Details of heat treatment cycle followed.</p> <p>Results of chemical analysis including tramp elements.</p> <p>Results of mechanical tests, including hardness test. All individual values shall be reported.</p> <p>Results of ultrasonic tests</p> <p>Results of surface crack examination</p> <p>Confirmation of the visual inspection</p> <p>Confirmation of the verification inspection</p> <p>Results of additional tests called for in the drawing/order.</p> <p>Mill test certificate</p>		
COPYRIGHT AND CONFIDENTIAL <small>The information on this documents is the property of Bharat Heavy Electrical Limited It must not be used directly or indirectly in any way detrimental to the interest of the company</small>	<p>15.0 DEVIATIONS</p> <p>Any deviation from this delivery specification has to be reported to BHEL immediately using Performa PU-25 supplied with the order. Any deviation is generally accepted only if this has been approved by BHEL in a written form.</p>		
स्वत्वाधिकार एवं गोपनीय <small>इस प्रलेख में दी गई सूचना भारत के श्रेष्ठ इलेक्ट्रिकल्स की सम्पत्ति है इसका प्रत्यक्ष एवं अप्रत्यक्ष रूप से किसी भी तरह प्रयोग, जो कि कंपनी के हित में हानिकारक हो न किया जाए।</small>	<p>16.0 CLEARANCE FOR DELIVERY:</p> <p>The clearance for dispatch is based on the total results of all tests performed considering the service stresses of the component. BHEL has the right to accept deviations of the specified values, if it is shown by individual judgment that the service properties are not reduced.</p> <p>The clearance does not release the manufacturer from the responsibility for hidden defects that are detected at later stage of manufacturing.</p>		
हस्ताक्षर एवं दिनांक SIGN & DATE	<p>17.0 PACKING AND MARKING:</p> <p>Forgings shall be suitably packed to prevent corrosion and damage during transit. Machined surfaces shall be properly protected with anti-corrosive compounds.</p> <p>Each package or forging (when supplied separately) shall be legibly marked with the following information:</p> <p>HW19391</p> <p>BHEL Order No.</p> <p>Drawing no.</p> <p>Batch No.</p> <p>Weight.</p> <p>Supplier's name</p>		
सामग्री सूची संख्या INVENTORY NO. P-2007	REV 02	निर्माणकर्ता WORKED BY Ashish Ranjan	 04.10.11
		जांचकर्ता CHECKED BY Gopal Krishnan	 4.10.11