

B-B (0,03:1)

FF (0,03:1)

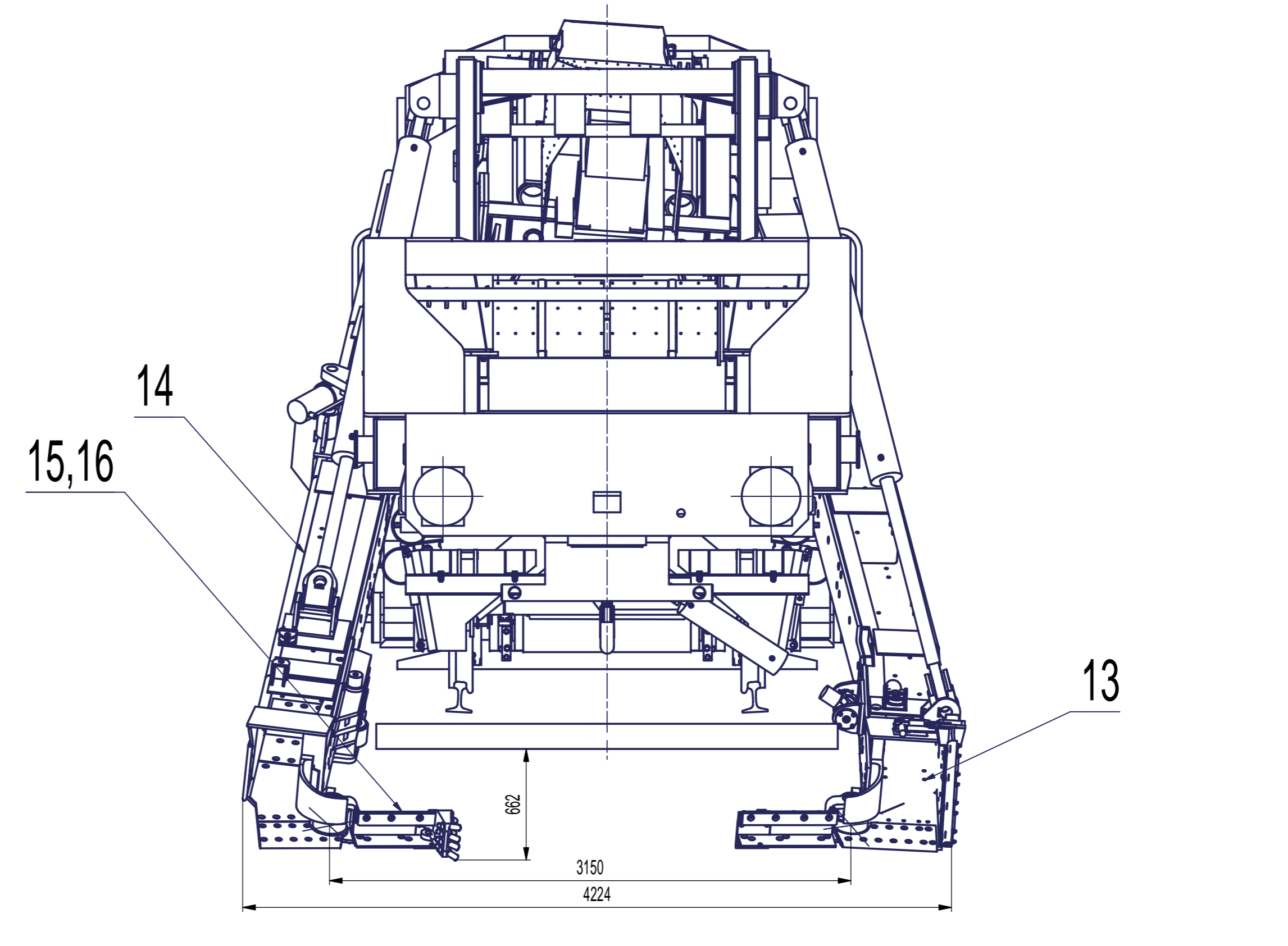
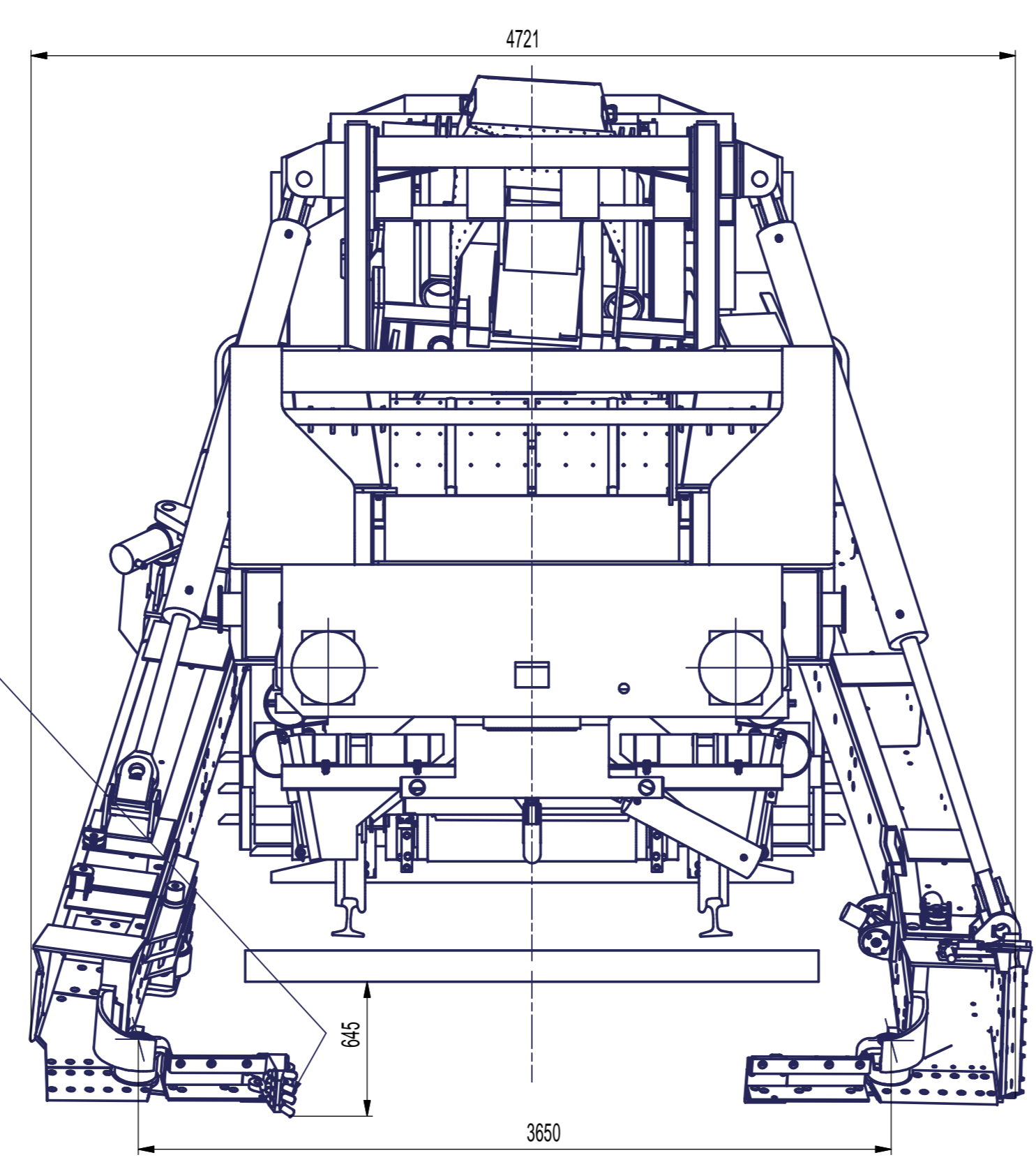
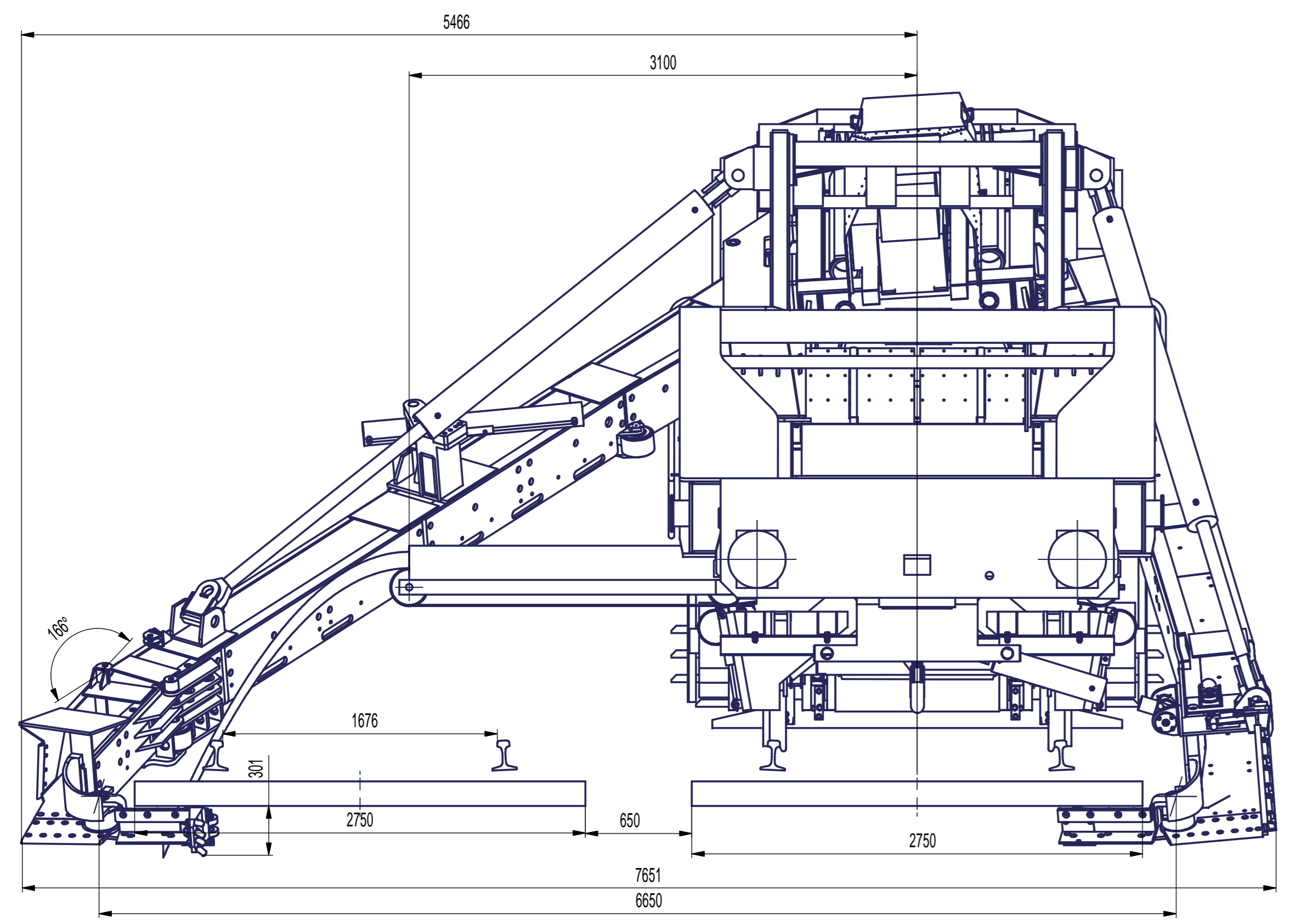
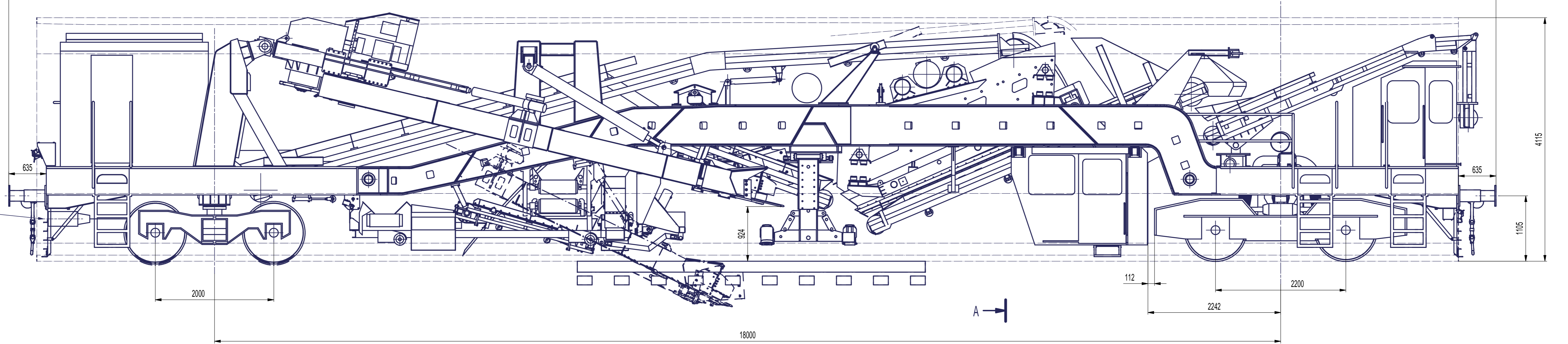
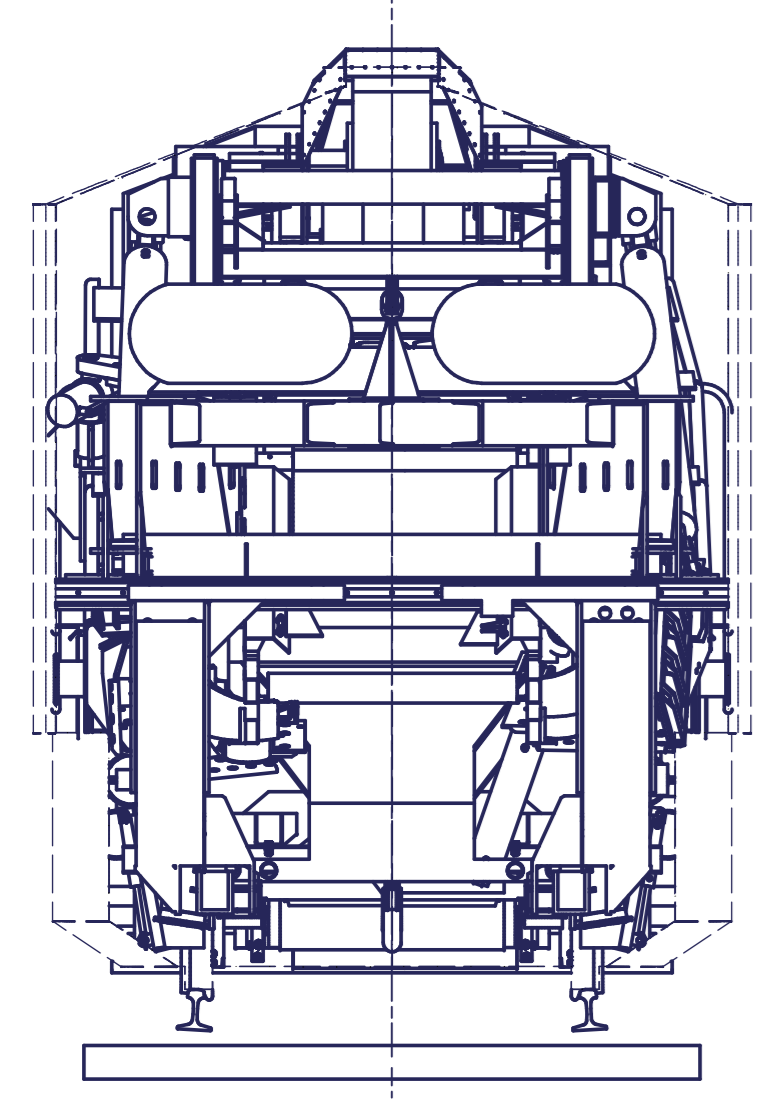
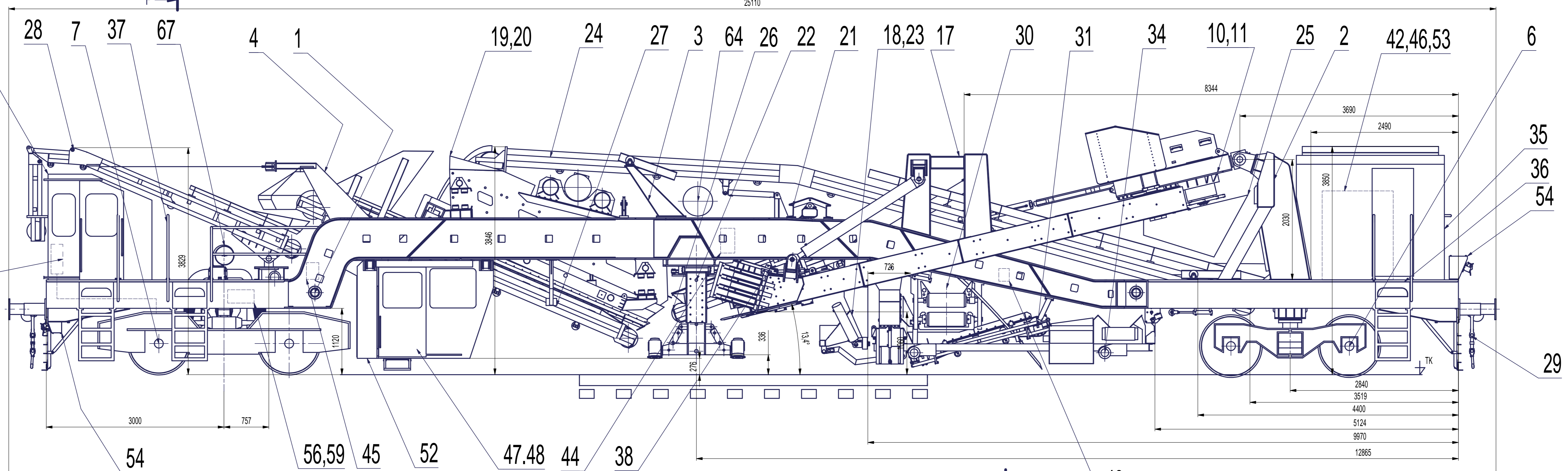
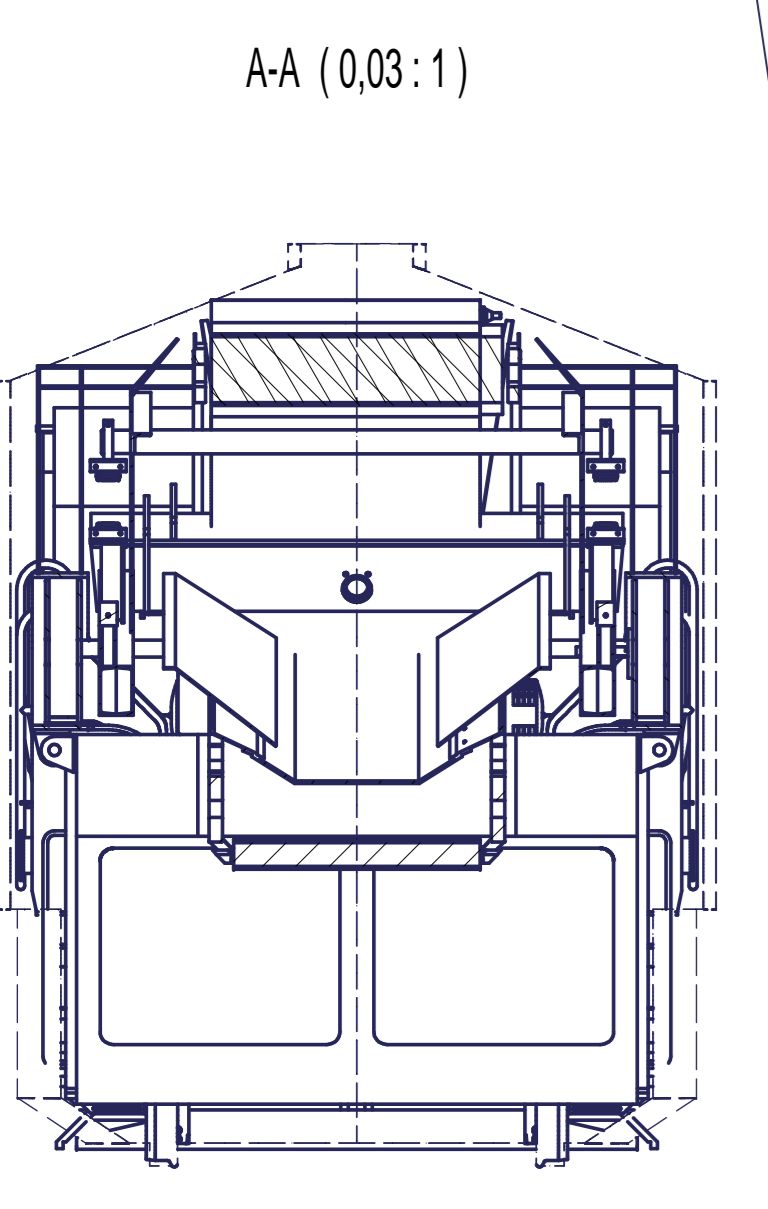
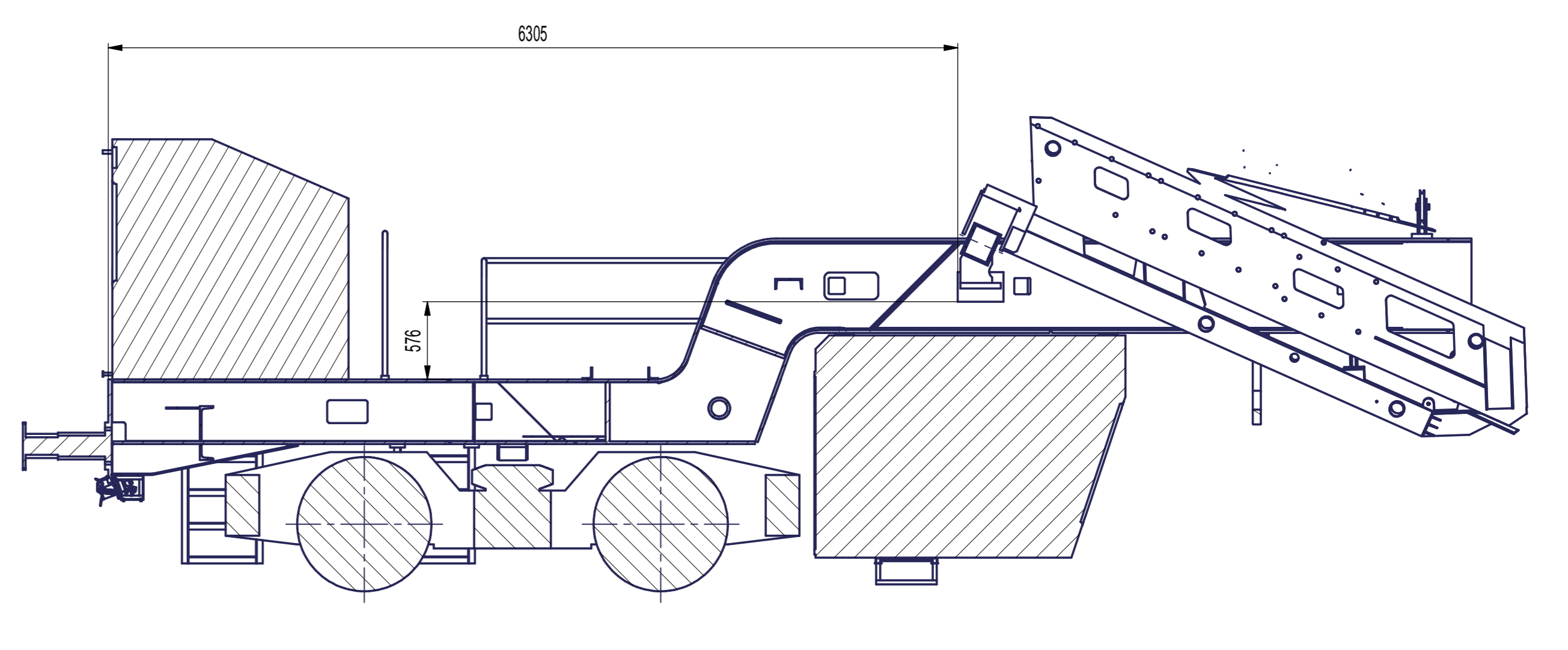
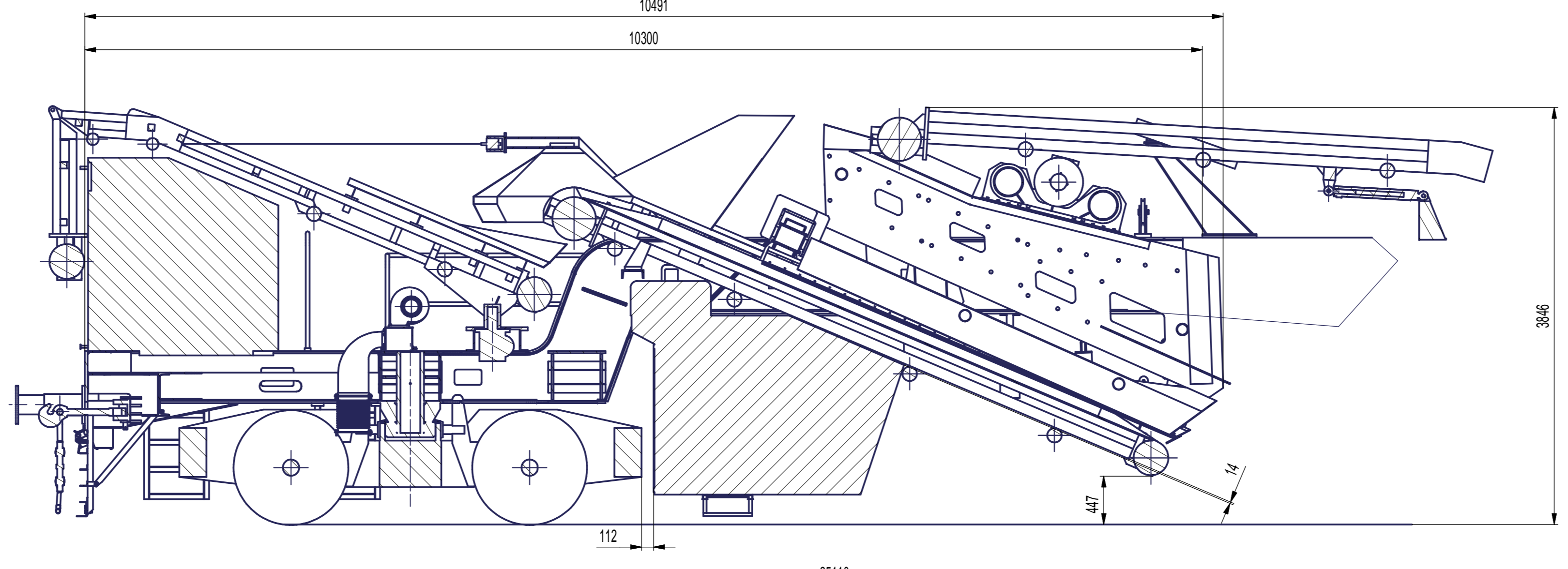
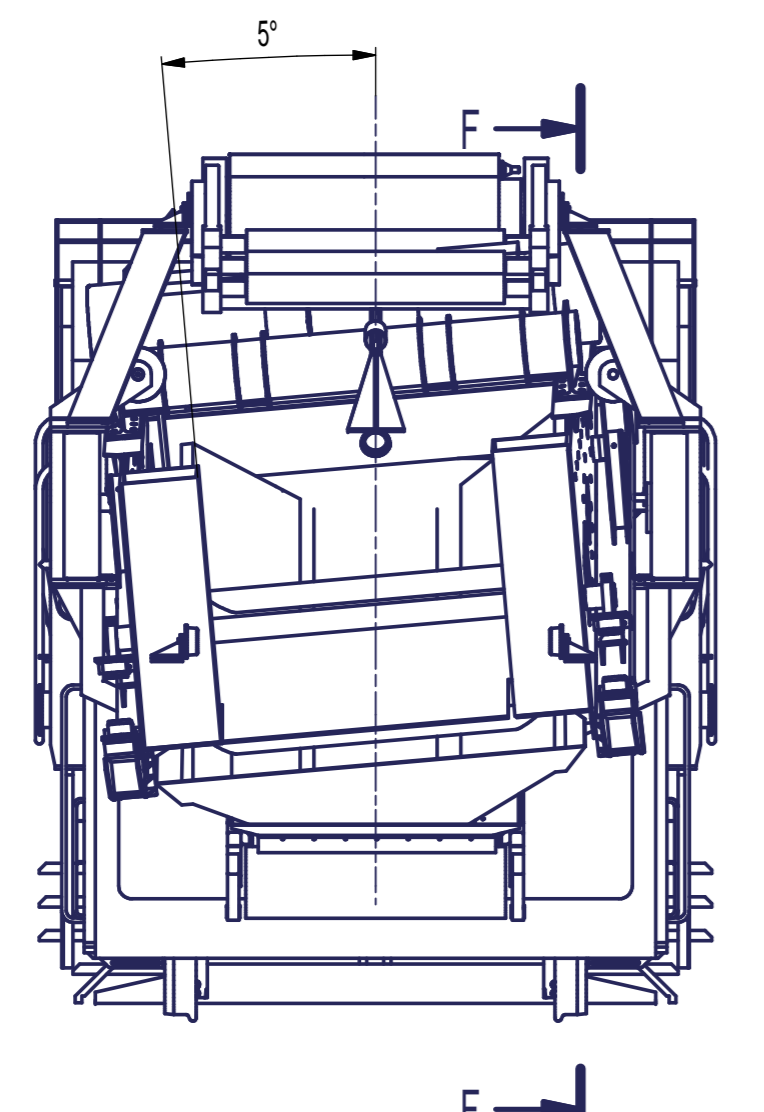
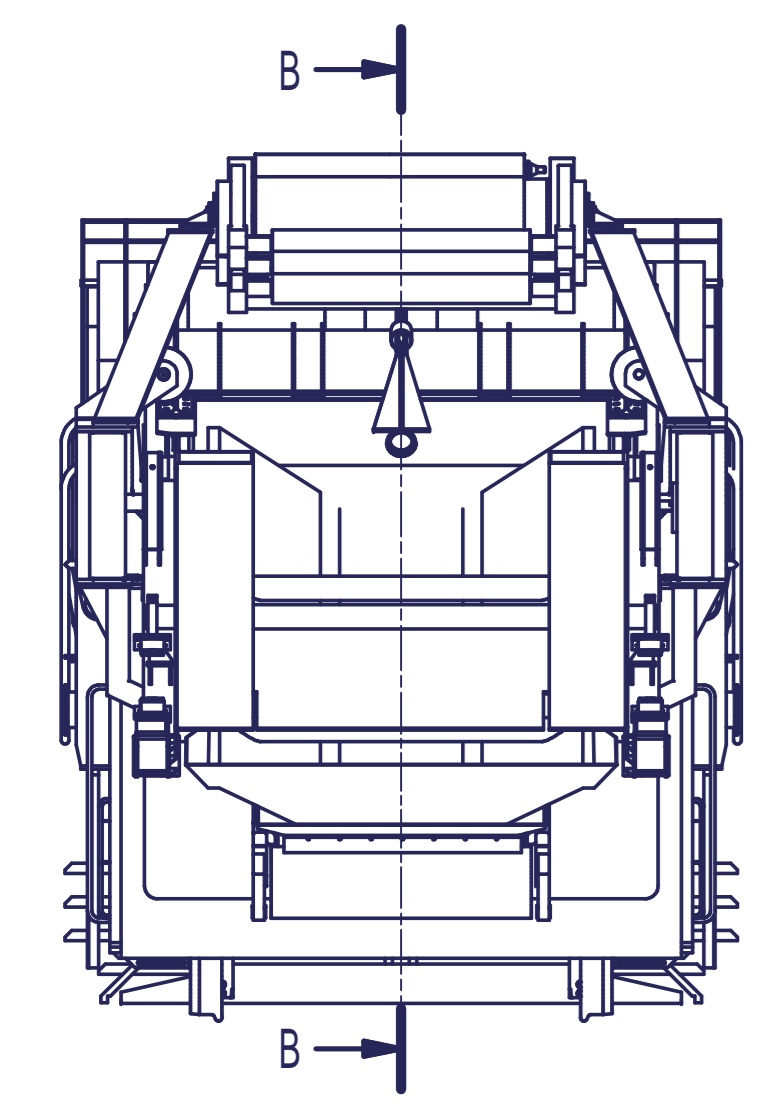

1	NÁTĚRY						3-317-69	70
1	NÁPISY							69
1	CHLAZENÍ TRAKČNÍCH MOTORŮ	130					2-317-67	68
1	NAKLÁPĚNÍ TRÍDIČE	50						66
1	CENTRÁLNÍ MAZÁNÍ	170					0-317-65A	65
1	ULOŽENÍ VZDUCHOJEMŮ	300						64
1	KRYT KLIMATIZACE	46					0-317-63	63
1	INSTALACE PNEUMATIKY TECHNOLOGICKÁ	500					0-317-62	62
1	INSTAL. PNEU. BRZDA	1000					02-27-1013	61
1	PNEU. SCHEMA TECHNOLOGICKÉ						3-317-60	60
1	PNEU. SCHEMA BRZDA						02-26-1016	59
1	ULOŽENÍ AKUMULÁTORŮ	200					1-317-58	58
1	PRÍSLUŠENSTVÍ	500					4-317-57	57
1	ELEKTRICKÝ AGREGÁT	60					2-43-21B	56
1	ČELNÍ RAMPA	200					2-317-54N	54
1	ROZVADĚČ RM-1	150					1-317-53	53
1	ROZVADĚČ RM-2	200					0-317-52	52
1	ELEKTRICKÁ INSTALACE	2388					3-317-51	51
1	FUNKČNÍ SCHEMA ELEKTRO						3-317-50	50
1	JÍZDNÍ KABINA	1456					0-317-48	49
1	VYSTRUJENÍ KABINY	122					2-317-48	48
1	PRACOVNÍ KABINA	1500					0-317-47	47
1	MOULDOVÝ HYDRAULICKÝ AGREGÁT	70					2-267-52.131A	46
1	BLOK IV	100					2-317-45	45
1	BLOK II	100					2-317-44	44
1	BLOK I	100					2-317-43	43
1	HYDRAULICKÝ AGREGÁT	500					0-317-42	42
1	HYDRAULICKÁ INSTALACE	500					0-317-41	41
1	FUNKČNÍ SCHEMA HYDRAULIKY						3-317-40	40
2	ZABRADLÍ OCHRANNÉ	40					1-317-38	39
1	ZABRADLÍ PŘEDNÍ	240					0-317-37	37
1	ZABRADLÍ ZADNÍ	120					1-317-36	36
1	KRYT AGREGÁTU	500					0-317-35A	35
1	SATELIT	1724					0-317-34	34
1	DOPRAVNÍK SATELITU	530					0-317-31	31
1	BOČNÍ DOPRAVNÍKY	1030					0-317-30	30
1	VYSTRUJENÍ RAMU	2600					0-317-29	29
1	OTOČNÝ DOPRAVNÍK	1481					1-317-28	28
1	DOPRAVNÍK ODPADU	1660					1-317-27	27
1	DOPRAVNÍK ŠTĚRKU	1116					1-317-26	26
1	NÁSPYKA	300						25
1	DOPRAVNÍK VYTŽEŇENÉHO MATERIÁLU	2500					1-317-24	24
1	ULOŽENÍ NÁSTAVCŮ	134					2-317-23	23
1	ZVEDACÍ ZAŘÍZENÍ	2800					0-317-22B	22
1	MANIPULACE S LÍSTY	252					1-317-21	21
1	ULOŽENÍ RAMU TRÍDIČE	1445					0-317-20N	20
1	TRÍDIČ	4285					0-317-19	19
1	ZÁVĚS SMĚROVACÍCH VÁLCOV A LÍSTY	468					1-317-18B	18
1	MANIPULACE SE ZLÁBY	2845					0-317-17B	17
7	NÁSTAVCE LÍSTY	850					0-317-16A	16
1	HRABACÍ LÍŠŤA	600					0-317-15A	15
1	ZLÁB SEŠŤUPNÝ	2150					0-317-14N	14
1	ZLÁB VZESTUPNÝ	2300					0-317-13N	13
1	BRZDA ZADNÍHO PODVOZKU	100					BHEL. I.HANSI	12
1	PODNOŽNÍ PŘETVŮ	3300					0-317-11N	11
1	KYVNÝ RAM	1700					0-317-10	10
1	HRABACÍ ŘETĚZ	3200					1-267-9	9
1	RUČNÍ BRZDA	300					BHEL. I.HANSI	8
1	HNAČÍ PODVOZEK	5000					BHEL. I.HANSI	7
1	NEHANNÝ PODVOZEK	2000					BHEL. I.HANSI	6
1	PODPĚRA OTOČNÉHO DOPRAVNÍKU	300					2-317-04	4
1	PODPĚRA DOPRAVNÍKU VYTŽEŇENÉHO MATERIÁLU	300					2-317-03	3
1	PODPĚRA HRABACÍHO ÚSTŘIŽNÍ	1500					1-317-02	2
1	Hlavní rám	18 000					0-317-01KR	1

P.k.	Název - Rozměr	Polotovary	Materiál	Sklad. pol.	Hm.	Číslo výkresu	Poz.
1	18 000						
2	300						
3	300						
4	300						
5	2000						
6	2000						
7	5000						
8	300						
9	300						
10	1500						
11	3300						
12	100						
13	2300						
14	2150						
15	600						
16	850						
17	2845						
18	468						
19	4285						
20	1445						
21	252						
22	2800						
23	134						
24	2500						
25	300						
26	1116						
27	1660						
28	1481						
29	2600						
30	1030						
31	530						
32							
33							
34	1724						
35	500						
36	120						
37	240						
38	40						
39							
40							
41	500						
42	500						
43	100						
44	100						
45	100						
46	70						
47	1500						
48	122						
49	1456						
50							
51	2388						
52	200						
53	150						
54	200						
55	60						
56							
57	500						
58	200						
59							
60							
61	1000						
62	500						
63	46						
64	300						
65	170						
66	50						
67	130						
68							
69							
70							