



Bharat Heavy Electricals Ltd
Boiler Auxiliaries Plant
Ranipet-632 406

EDC / AIR PREHEATERS
TECHNICAL SPECIFICATION
Effective Date: 02.09.2011

Specification No : RAH 429

Rev. No : 00

Page No : 01 of 03

01 Item : Main Drive Speed Reducer 9APB (3 Input, Down Shaft Output, 3 ORC)

02 Application

Used for driving the rotor of Regenerative Air Preheater in coal fired power stations. Two input shafts are required to connect them to the main Electric Motor drive and to the standby Electric Motor. A third input shaft is also required to connect to the emergency compressed Air Motor drive. All the input shafts should have over-running clutch built-in as a part of the speed reducer. A pinion is mounted on the output shaft of the reducer, which engages to a Pin rack provided in the rotor of the air heater. All the drive motors are mounted in brackets, which are to be attached to the speed reducer casing.

03 Prime Movers

- a) Main / Standby - Electric motor 3 Ph, 50 Hz.
- b) Emergency - Air motor of lower speed & lower KW

04 Input RPM

1450

05 Output RPM

14.74

06 Transmitting Power

- a) Continuous – 37 KW
- b) Peak – 111 KW
- c) Motor Rating - 37 KW

07 Peak Input Torque

74 Kg-m

08 Conditions of service

- a) Duration : continuous - 24 hours daily
- b) Nature of load : smooth
- c) Starting torque : 50 Kg-m
- d) Momentary Max over load : 400 %
- e) Ambient Temperature : 55°C
- f) Environment : Dusty and Humid
- g) Direction of rotation of high speed shaft : Must be capable of rotating in either direction (clockwise or counter-clockwise)

09 Coupling method

- a) High speed shaft - Electric motor by fluid coupling & Air motor by flexible coupling.
- b) Low speed shaft - Pinion mounted (Pitch circle dia of pinion - 1270 mm, Pressure angle - 20°)

00 02.09.11

[Signature]

[Signature]

[Signature]

Fresh issue

Rev.No Date Prepared Checked Approved Record of Revisions.

Specification No : RAH 429	Rev. No : 00	Page No : 02 of 03
10	General arrangement of Assembly, Input shaft details & Output Shaft details	As per sketch in page 03 of 03
11	<p>PAINTING</p> <ul style="list-style-type: none"> a) All external surfaces, which require painting, shall be cleaned by power tool before applying paint. b) 2 coats of Red Oxide Zinc Chrome (IS : 2074) primer paint shall be applied to have a dry film thickness of 50 microns. c) Finally, 3 coats of synthetic enamel (IS : 2932) finish paint of colour Smoke Grey shade no : 692 of IS : 5 shall be applied to have a dry film thickness of 60 microns. d) Total dry film thickness shall be 100 microns (minimum) after final coat. 	
12	<p>GENERAL</p> <ul style="list-style-type: none"> a) Dimensions mentioned in the sketches are not to be exceeded. b) Speed reducers have to satisfy AGMA specifications for durability of 120,000 hours life at rated KW. c) Service factor 1.25 d) Bearings to have minimum B-10 life of 50,000 hours at rated KW. e) Lubrication arrangement shall be provided for all bearings and gear meshes above oil level. f) At 400% of motor rating, tooth stress should not exceed 70% of yield point of tooth material. g) Over Running Clutches shall be mounted in all the input shafts such that when one input shaft is driven the other two input shafts shall not rotate. h) The Over Running Clutch shall be without Oil Seal and shall be suitable for Sump Oil Lubrication. It shall be of 'Daido', 'Formsprag' or 'Renold' Make only. i) Double seal is required at high speed shafts and at low speed shaft. j) In the event of first order on a vendor, the first lot of speed reducers will be subject to test at our works. The procedure before each starting is to obtain full backlash inside the reducer plus 1 degree backlash between the tooth of pinion on the low speed shaft and a stop. The motor is then turned on. This is to be done 500 times without fracture of speed reducer components. k) The casing of the speed reducer shall be of fine-grained Cast Iron per IS 210 FG 260 or equivalent. l) All input and output shafts shall be supplied with keys. m) 3 copies of O & M manual to be supplied along with Reducer. n) Only latest revision shall be referred for all the standards specified. 	
13	<ul style="list-style-type: none"> a) Vendor shall submit the Dimensional drawing indicating Materials of Construction of all the parts and Weight, for our approval. b) In the event of first order on a vendor, the vendor shall submit (i) Gear calculations as per AGMA, (ii) Tooth stress calculations at 400% rated power and (iii) Quality Plan, for our approval. 	
14	<p>INSPECTION</p> <ul style="list-style-type: none"> a) Inspection by BHEL. b) Necessary Material Compliance Certificate and No-load Run Test certificate (indicating Noise level, Vibration, and Temperature Rise) shall be submitted. 	

Speed Reducer 9APB – 3 Input, Output Downshaft, 3 ORC

GENERAL ARRANGEMENT

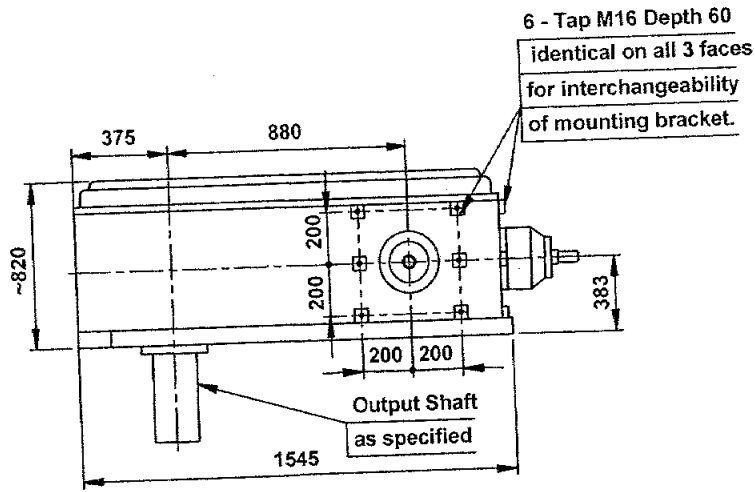

ELEVATION

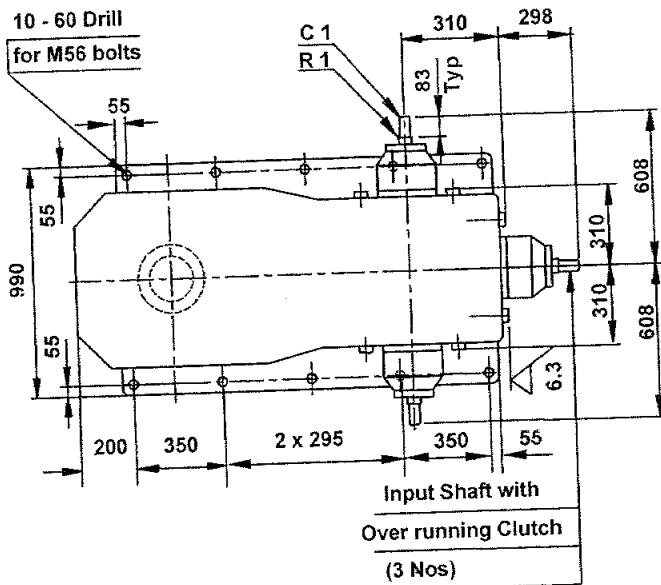

PLAN

All dimensions are in mm

OUTPUT SHAFT DETAILS

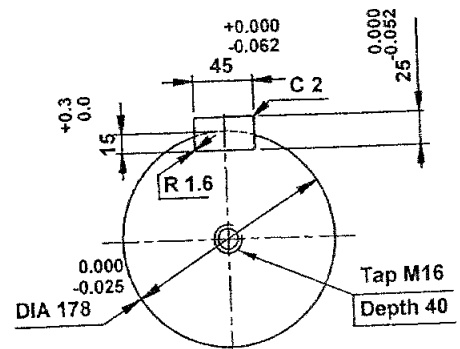
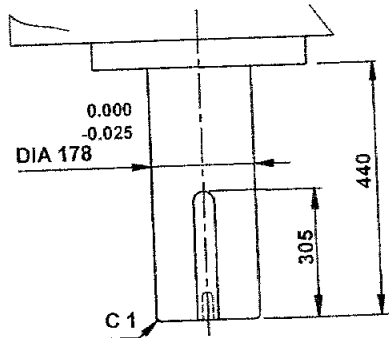

OUTPUT SHAFT END

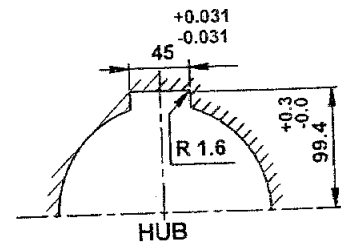

INPUT SHAFT DETAILS

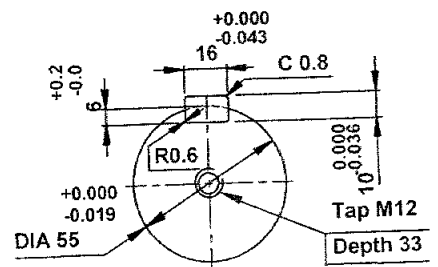

INPUT SHAFT END

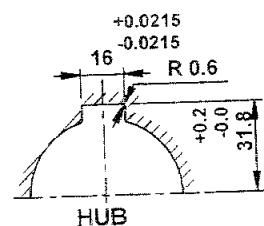



Quality Assurance
MANUFACTURER'S NAME & ADDRESS
 M/S BHEL: BAP/ RANIPET
 TAMIL NADU-632 406

STANDARD QUALITY PLAN

ITEM /SUB SYSTEM:
Speed Reducer
(Type I, II, III, 4HR, 8APB & 9APB)

DOC. NO SQP APH 111

Rev. No: 02

Date: 17/06/2015

Page: Page 1 of 5

SL NO	COMPONENT & OPERATION	CHARACTERISTICS	Class	TYPE OF CHECK	QUANTUM OF CHECK	REFERENCE DOCUMENTS	ACCEPTANCE NORMS	FORMAT OF RECORD	Agency		REMARKS
									M	B	
1	2	3	4	5	6	7	8	9	10	11	12

1.0	Raw Material Inspection										
1.1	Gear Case (CI)	Surface Defect	Major	Visual	100%	Vendor Drawing	As per relevant Standard	Inspection Report	W	V	Material specified as per BHEL approved drawing
1.2	Pinion shaft, Gears(Case hardened steel)and output shaft	Tensile Strength	-do-	Tensile Strength	Sample Per heat	-do-	-do-	-do-	W	V	
		Chemical	-do-	Chemical Analysis	-do-	-do-	-do-	-do-	W	V	
2.0	Inprocess Inspection	SOUNDNESS	-do-	UT	100%	-do-	-do-	-do-	W	V	
		Microstructure	-do-	Microtest	100%	-do-	-do-	-do-	W	V	
2.1	Gear Case	Shot blasting	-do-	Visual	100%		.sa 2 ½	-do-	W	V	
		Primer Painting (1 coat of zinc phosphate -white - shade)	-do-	-do-	100%	As per approved Drg	30 microns (Min)	-do-	W	V	

LEGENDS:
 M - Manufacturer, BHEL SHOP /Subcontractor,
 B - BHEL QC/ Authorized Inspection agency, P - Perform,
 V - Verification of reports, W - Witness, TC - Test certificate,
 R - Report, HT - Heat treatment.

Prepared By (S.DAMODARAN) DY.MANAGER / QA	Reviewed By (R.RUNACHALAM) SR MANAGER / QA	Approved By (J.RAVISHANKAR) SDGM/QA,BE,QC(Proc)
---	--	---



Quality Assurance
MANUFACTURER'S NAME & ADDRESS
 M/S BHEL: BAP/ RANIPET
 TAMIL NADU-632 406

RANIPET

STANDARD QUALITY PLAN

ITEM /SUB SYSTEM:

Speed Reducer

(Type I, II, III, 4HR, 8APB & 9APB)

DOC. NO **SQP APH 111**

Rev. No: **02**

Date: **17/06/2015**

Page: **Page 2 of 5**

SL NO	COMPONENT & OPERATION	CHARACTERISTICS	Class	TYPE OF CHECK	QUANTUM OF CHECK	REFERENCE DOCUMENTS	ACCEPTANCE NORMS	FORMAT OF RECORD	Agency		REMARKS
									M	B	
1	2	3	4	5	6	7	8	9	10	11	12

		Dimensions	-do-	Measurement	100%	BHEL appvd drawing / vendor drawing	BHEL appvd drawing / vendor drawing	-do-	W	V	(##) When back wall echo is set to 100% of FSH in sound area.
2.2	Pinion shaft & gears	Dimensions	-do-	-do-	-do-	-do-	-do-	-do-	W	V	
		Soundness	-do-	UT	100%	ASTM A 388 (##)		-do-	W	V	a) Defect echo not to exceed 20% of FSH during scan.
		Surface Hardness	-do-	Hardness	100%	BHEL appvd drawing / vendor drawing		-do-	W	V	
		Case Depth	-do-	Case Depth	100%	-do-		-do-	W	V	
2.3	Output Shaft & Input shaft	Dimension	Major	Measurement	100%	BHEL appvd drawing / vendor drawing	BHEL appvd drawing / vendor drawing	-do-	W	W	b) Back wall echo loss permissible 20% of FSH
		Soundness	-do-	UT	100%	ASTM A 388 (##)		-do-	W	V	
		Surface Hardness	-do-	Hardness	-do-	BHEL approved drawing.		-do-	W	V	
2.4	Pre Assembly Test	Blue match	-do-	Visual	-do-	-do-	25%min for Helical & 40%for Bevel gear DIN 3990	-do-	W	W#	W#- NOTE 1

LEGENDS:

M - Manufacturer, BHEL SHOP /Subcontractor,
 B - BHEL QC/ Authorized Inspection agency, P - Perform,
 V - Verification of reports, W - Witness, TC - Test certificate,
 R - Report, HT - Heat treatment.

Prepared By (S.DAMODARAN) DY.MANAGER / QA	Reviewed By (R.ARUNACHALAM) SR MANAGER / QA	Approved By (J.RAVISHANKAR) SDGM/QA,BE,QC(Proc)
---	---	---



Quality Assurance
MANUFACTURER'S NAME & ADDRESS
 M/S BHEL: BAP / RANIPET
 TAMIL NADU-632 406

STANDARD QUALITY PLAN

ITEM /SUB SYSTEM:
Speed Reducer
 (Type I, II, III, 4HR, 8APB & 9APB)

DOC. NO SQP APH 111

Rev. No: 02

Date: 17/06/2015



Page: Page 3 of 5

SL NO	COMPONENT & OPERATION	CHARACTERISTICS	Class	TYPE OF CHECK	QUANTUM OF CHECK	REFERENCE DOCUMENTS	ACCEPTANCE NORMS	FORMAT OF RECORD	Agency		REMARKS
									M	B	
1	2	3	4	5	6	7	8	9	10	11	12

		Bearings	-do-	make	-do-	-do-	-do-	-do-	W	V	
		Over running clutch	-do-	make	-do-	-do-	-do-	-do-	W	V	
3.0	Final Inspection										
3.1	Assembly	Verification of arrangement/ Direction of rotation	Critical	Visual	100%	BHEL appvd drawing /vendor drawing	BHEL appvd drawing /vendor drawing	-do-	W	W	
3.2	Mounting dimension (Air motor, electric motor, spare motor, distance between input drive /gear box to output shaft) etc	dimension	-do-	-do-	-do-	-do-	-do-	-do-	W	W	
3.3	No load test run	Leakage	Critical	Visual	100%	No leakage	No leakage	-do-	W	W	
		Reduction ratio	Major	Measurement	100%	BHEL appvd drawing /vendor drawing	BHEL appvd drawing /vendor drawing	-do-	W	W	
		Temperature rise (4hrs)	-do-	-do-	-do-	Ambient temperature	30 degree over ambient temperature	-do-	W	W	

LEGENDS:

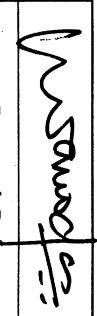
M - Manufacturer, BHEL SHOP /Subcontractor,
 B - BHEL QC/ Authorized Inspection agency, P - Perform,
 V - Verification of reports, W - Witness, TC - Test certificate,
 R - Report, HT - Heat treatment.

Prepared By (S.DAMODARAN) DY.MANAGER / QA 	Reviewed By (R.RAVINACHALAM) SR MANAGER / QA 
Approved By (J.RAVISHANKAR) SDGM/QA,BE,QC(Proc) 	



Quality Assurance
MANUFACTURER'S NAME & ADDRESS
 M/S BHEL: BAP / RANIPET
 TAMIL NADU-632 406

STANDARD QUALITY PLAN

ITEM /SUB SYSTEM:
Speed Reducer
 (Type I, II, III, 4HR, 8APB & 9APB)



DOC. NO SQP APH 111
Rev. No: 02
Date: 17/06/2015
 Page: Page 4 of 5

SL NO	COMPONENT & OPERATION	CHARACTERISTICS	Class	TYPE OF CHECK	QUANTUM OF CHECK	REFERENCE DOCUMENTS	ACCEPTANCE NORMS	FORMAT OF RECORD	Agency		REMARKS
									M	B	
1	2	3	4	5	6	7	8	9	10	11	12

		Noise level (85 db max , 4 hrs run) Maximum	Major	Measurement	100%	BHEL appvd drawing /vendor drawing	BHEL appvd drawing /vendor drawing	-do-	W	W	
		Vibration	-do-	-do-	100%	Velocity – Max. 7.5mm/sec Displacement- Max. 50 µ	Velocity – Max. 7.5mm/sec Displacement- Max. 50 µ	-do-	W	W	
		Lube oil pump	Major	Make	100%	BHEL appvd drawing /vendor drawing	BHEL appvd drawing /vendor drawing	-do-	W	W \$	W \$- NOTE-2
		Pressure gauge	Major	make	100%	BHEL appvd drawing /vendor drawing	BHEL appvd drawing /vendor drawing	-do-	W	W \$	
		Oil seals	Major	make	100%	BHEL appvd drawing /vendor drawing	BHEL appvd drawing /vendor drawing	-do-	W	V	

LEGENDS:

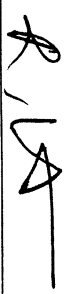
M - Manufacturer, BHEL SHOP /Subcontractor,
 B - BHEL QC/ Authorized Inspection agency , P - Perform,
 V - Verification of reports , W - Witness, TC - Test certificate,
 R - Report , HT - Heat treatment.

Prepared By (S.DAMODARAN) DY.MANAGER / QA 	Reviewed By (R.ARUNACHALAM) SR MANAGER / QA 	Approved By (J.RAVISHANKAR) SDGM/QA,BE,QC(Proc) 
--	--	--



Quality Assurance
MANUFACTURER'S NAME & ADDRESS
 M/S BHEL: BAP / RANIPET
 TAMIL NADU-632 406

STANDARD QUALITY PLAN

ITEM / SUB SYSTEM:
Speed Reducer
 (Type I, II, III, 4HR, 8APB & 9APB)

DOC. NO SQP APH 111

Rev. No: 02

Date: 17/06/2015

Page: Page 5 of 5

SL NO	COMPONENT & OPERATION	CHARACTERISTICS	Class	TYPE OF CHECK	QUANTUM OF CHECK	REFERENCE DOCUMENTS	ACCEPTANCE NORMS	FORMAT OF RECORD	Agency		REMARKS
									M	B	
1	2	3	4	5	6	7	8	9	10	11	12

4.0	Painting	Visual	Major	Visual	100%	2 coats of Red Oxide Zinc Phosphate Primer to IS: 12744 DFT of 60 micron min. and 3 coats of Synthetic Enamel to IS 2932 Smoke Grey Shade No. 692 of IS 5 DFT of 60 micron min. Total DFT of 120 micron min.	-do-	W	W		
5.0	Packing (polythene cover, wooden packing)	Visual	Major	Visual	100%	BHEL appvd drawing / vendor drawing	-do-	W	W@		

Note:-

- 1) W#-One number of each 50 nos will be dismantled to verify the record for Type I, II, 8APB & 9APB only.
- 2) W\$ - NOT APPLICABLE FOR SPEED REDUCER TYPE III & 4 HR.
- 3) Protection cover screws should not be of through hole type. 4) W @ Packing : One typical packing is to shown to TPI .

RECORD OF REVISION

DETAILS OF REVISION MADE

REV NO	DATE	DETAILS OF REVISION MADE
REV. 00	--	Original Issue - First submission
REV 01	25-02-2010	Type 4HR also added in the scope. Dismantling requirement is restricted to Type I&II only.
REV 02	17-06-2015	Type 8APB & 9APB also added in the scope. Vibration value updated. Dismantling requirement is restricted to Type I,II,8APB & 9APB only.

LEGENDS:
 M - Manufacturer, BHEL SHOP /Subcontractor,
 B - BHEL QC/ Authorized Inspection agency, P - Perform,
 V - Verification of reports, W - Witness, TC - Test certificate,
 R - Report, HT - Heat treatment.

 Prepared By (S.D.AMODARAN) DY.MANAGER / QA	 Reviewed By (R.ARUNACHALAM) SR MANAGER / QA	 Approved By (J.RAVISHANKAR) SDGM/QA,BE,QC(Proc)
--	---	---



ANNEXURE-A to Enquiry 3250478E dated 15.07.2015

Open Tender for Procurement of Main drive Speed Reducer 9 APB & Spares as per our Specification :RAH-429/Rev00

NOTICE INVITING TENDER

Sealed Tenders are invited for the supply of Main drive Speed Reducer 9 APB and Spares as per the Specification, Standards and Quantities as listed below.

SCOPE : SUPPLY OF Main drive Speed Reducer 9 APB: RAH-429/Rev00.

Sl No	Material code	Description	Model No	Material Specification	Unit	Qty	Delivery Schedule
01	R52407390001	Main drive Speed Reducer 9 APB (3 Input, Downshaft Output, 3 ORC), Output shaft Rotation- Clockwise (Viewed from Top)	-	RAH-429/Rev00	No	3	24.03.16
02	R52407390002	Main drive Speed Reducer 9 APB (3 Input, Downshaft Output, 3 ORC), Output shaft Rotation- Counter Clockwise (Viewed from Top)	-	RAH-429/Rev00	No	3	24.03.16
03	R52507980001	Main drive Speed Reducer 9 APB as per SI No 01	-	RAH-429/Rev00	No	1	24.06.16
04	R52407980002	Main drive Speed Reducer 9 APB as per SI No 02	-	RAH-429/Rev00	No	1	24.06.16
05	R52407980003	Set of Gears, Pinion & Shaft for 9APB Speed Reducer	-	-	ST	1	24.06.16
06	R52407980004	Set of Bearings for 9APB Speed Reducer	-	-	ST	1	24.06.16
07	R52407980005	Set of Seals,Gaskets & O Ring for 9APB Speed Reducer	-	-	ST	1	24.06.16
08	R52407980006	Over Running Clutch for 9APB Speed Reducer	-	-	No	1	24.06.16

The supplier shall follow our Specn:RAH-429/00 & QAP: SQP APH 111 Rev 02.
Destination : BHEL Stores, Ranipet 632406, Tamil Nadu

BHEL reserves the right that the Price Bid opening will be done through conventional sealed bid opening mode (OR) Reverse Auction method (English method),

New supplier/vendor shall submit SUPPLIER REGISTRRTION FORM (SRF) thro' ONLINE PORTAL. You are requested to visit our Web Site : www.bhel.com and click under heading 'Supplier Registration' and fill up the 'Supplier Registration Form' which is available in the Online Supplier Registration Portal. (or Copy the following URL Link and paste in the web link address: http://www.bhel.com/vender_registration/vender.php and proceed with). After successful submission, a hard copy of the same with all the annexures (as called for) may please be sent to

*Mr. K.Jothi Arulanandam, Manager-Purchase, Supplier Development Cell,
email: kj@bhelrpt.co.in, phone: 04172 284474 / 4333
Bharat Heavy Electricals Limited, RANIPET, Tamil Nadu, India. PIN:632 406*

Qualifying criteria for the new vendors -Pre-qualification creteria

1. The supply shall be as per our Specification RAH-429 Rev 00 & QAP: SQP APH 111 Rev 02 only. Deviation if any, the "deviation summary " shall be submitted for our technical evaluation.
2. The Bidder is required to meet the proven-ness criteria for Air Preheater Speed Reducer as per criteria stipulated below.

The Bidder should have previously designed, manufactured and supplied the Speed Reducer for Air Preheater in a 500 MW Boiler unit or higher rating and shall be in successful operation in at least one (1) plant for a period not less than one (1) year on the date of techno-commercial bid opening.

3. The following information should be submitted by the vendor where the Speed Reducer has been supplied:
 - a. Name of the customer where the Speed Reducers are installed.
 - b. MW rating of the Boiler.
 - c. Complete postal address of the customer.
 - d. Name, designation and contact details of the contact person of the customer.
 - e. Month & Year of commissioning.
 - f. Copy of performance certificate from the customers regarding satisfactory performance of the supplied items.
 4. BHEL reserves the right to verify the information provided by vendor. In case the information provided by vendor is found to be false / incorrect, the offer shall be rejected.
-