



EDC- Gates &
Dampers

Bharat Heavy Electricals Ltd
Boiler Auxiliaries Plant

Ranipet-632 406

TECHNICAL DOSSIER for 57-583

FGD BYPASS DAMPER

NTPC VINDHYACHAL -1x 500MW (R549)

PAGE NO 01 OF 01

SINo	Particulars	Document reference
1	General specification of FGD Bypass Bi-plane Damper	GDRS: 018
2	P&ID of FGD Bypass Damper & Seal Air Piping	4610-101-05RP
3a	BHEL Quality Plan	R502/04
b	Sample MQP format for Bidder's reference	1 page enclosure
4a	NTPC format for Evaluation Report	QS-01-QAI-P-04 / F1-R2 (1 page)
b	- For Bidders information - To be filled and submitted by Bidder	QS-01-QAI-P-04 / F2-R1(7 pages)
5	Painting schedule	PS VINDHYACHAL R549 Rev00 dt:16.08.2012
6	Technical Specification for LT Motor of Seal Air Blower	TECI: LT MOTOR: Rev01
7	Technical specification of Pneumatic cylinder	TCI: 143. Rev.08
8	Technical specification of Smart Positioner	TDC: TCI: 317 /REV.02
9	TB Wiring diagram of Power cylinder	3-97-599-21822 Rev.00
10	Quality Plan for Pneumatic Actuator	QA: CI: STD: QP: 42. Rev.04
11	Packing procedure for Actuators & Electrical equipments	QA: CI: STD: PR:03 /Rev.02
12	NTPC Technical specification for Instrumentation	Inst_Spec - 57583
13	Leak Tightness Type test procedure	G&D : LTTTP
14	Data sheet- FGD Bypass Damper	DS – 57583
15	Proforma Invoice - FGD Bypass Damper (Price Schedule)	PI – 57583
16	Document Submission Check list	CL-BL-57583

Filled up sl. nos. 4b and sl.nos. 14 to 16 to be submitted along with Technical Offer.

Rev. 00.dt.04/11/2014 : Original Issue

Prepared	Checked	Approved
M. Suresh Engineer –EDC /G&D	V. Kesavan Sr. Manager – EDC /G&D	D. Ashwin Dhinakar Sr. Manager – EDC /G&D

VINDHYACHAL– 1x 500MW (R549)
FGD BYPASS DAMPER

SPECIFICATION No.: GDRS: 018 / Rev.00

TECHNICAL SPECIFICATION

for

FLUE GAS DESULFURIZATION BYPASS BI-PLANE DAMPER

CUSTOMER : NTPC LIMITED



Prepared	Checked	Approved
	 04/11/2014	 04/11/2014
M. Suresh Engineer- EDC/ G&D	V. KESAVAN Sr. Manager- EDC/ G&D	D. ASHWIN DHINAKAR Sr. Manager– EDC/ G&D

Rev.01	

CONTENTS

SINo	Particulars	PageNo
1	Project Information	4
2	Application	5
3	Scope of supply	5
4	Working Environment	5 -6
5	Operational Requirement	6 -7
6	Design Criteria	7 - 8
7	Construction Details	8 -9
8	Material of Construction:-	9 - 10
9	Seal Air system	10
10	Actuator System for Damper	10 - 11
11	Painting Requirements:	11
12	Quality Plan &Testing	11 - 12
13	Packing for dispatch	12
14	Qualification Requirement (Offer Acceptance Criteria)	12 - 13
15	Responsibility	13 - 14
16	Assistance for Erection & Commissioning	14
17	Spares	14
18	Special Tools	15
19	Instrumentation in vendor's scope of supply	15
20	Auxiliary power consumption & Operating pressure details	15 -16
21	Documents to be submitted	17 -18
22	Key plan drawing of Bypass damper	19
23	Flue Gas property	20
24	P&ID of FGD Bypass damper & seal air piping	4610-101-05RP

25	BHEL Quality Plan	R502/ 04
26	MQP Sample format for reference only	1 page
27	NTPC format – Evaluation Report (for information only)	QS-01-QAI-P-04/ F1-R2 (page 1 of 1)
28	NTPC format – Evaluation Report (to be filled up and submitted by bidder)	QS-01-QAI-P-04/ F2-R1 (page 1 to 7 of 7)
29	Painting Schedule	PS VINDHYACHAL R549 REV.00 dt 16.08.2012 (1 page)
30	Technical Specification for LT Motor (Applicable for Motor of seal air blower)	TECI: :LT MOTOR: REV 01
31	Technical specification of Pneumatic cylinder	TCI: 143. Rev.08
32	Technical specification of Smart Positioner	TDC: TCI: 317 /REV.02
33	TB Wiring diagram of Power cylinder	3-97-599-21822 Rev.00
34	Quality Plan for Pneumatic Actuator	QA: CI: STD: QP: 42. Rev.04
35	Packing procedure for Actuators & Electrical equipments	QA: CI: STD: PR:03 /Rev.02
36	NTPC Technical Specification for Instrumentation	Inst_Spec-57583
37	Leak Tightness Type Test Procedure	G&D: LTTP
38	Data sheet for FGD Bypass damper	DS-57583
39	Total Final Price Schedule (Proforma Invoice)	PI- 57583
40	Check List for FGD Bypass damper	CL-BL-57583

Filled up sl. nos. 28 and 38 to 40 shall be submitted by bidder along with Technical Offer.

1.0.0	PROJECT INFORMATION	
	▪ Owner	NTPC Ltd.
	▪ Buyer	BHEL, Ranipet
	▪ Process/ application	Wet Lime Stone FGD system
1.1.0	SITE CONDITIONS	
	▪ Ambient temperature (Guarantee)	27 Deg C
	▪ Ambient temperature(Max.) ▪ Ambient temperature (Min.)	50 Deg C 6 Deg C
	▪ Relative Humidity	60%
1.2.0	LOCATION and APPROACH	
	▪ Project location	Vindhyachal STPS, Vindhyanagar
	▪ District	Singrauli
	▪ State	Madhya Pradesh
	▪ Height above sea level	281m
1.3.0	Other Project details	
	▪ Seismic load	As per IS: 1893 (Part I); 2002 and IS: 1893 (Part 4): 2005
1.4.0	Wind Load	As per IS: 875 (Part-3)
	a) Basic wind speed at 10 meters above the mean ground level	47 m/s
	b) Risk coefficient, " K"	1.07
	c) Category of terrain	Category – 2

2.0 Application:

Bi-plane * damper is located in between ID fan and chimney. This damper is required for diverting the flue gas into FGD plant for sulphur removal treatment instead of allowing the flue gas directly into the chimney (Refer Key plan, clause no. 22)

* - Twin blade louver damper i.e. Two plates mounted to a single shaft trunnions (stub shafts) and are reinforced with stiffeners between the plates or other approved tandem seal blade designs.

3.0 Scope of supply:

Design, Manufacture, Testing, Painting & Packing for Shipment and Assistance for Erection & Commissioning including:

- 3.1 Bi-plane damper assembly (1 No.) with mating flanges on both sides (Upstream & Downstream)
- 3.2 Electro Pneumatic Actuator(s) (quantity as per technical requirement , also refer specification for Power cylinder- TCI:143.Rev.08 & Smart positioner- TDC:TCI :317 Rev.02 enclosed)
- 3.3 Seal air system with–
 - (a) Blower with motor- 2 x 100%, with check valves at the outlet.
 - (b) Heater & its related accessories/ Instrumentation(Refer clause 19.0)
 - (c) Air operated knife edge gate, or butterfly valve with solenoid valve & air filter regulator and
 - (d) seal air piping from Blower till seal air opening in damper frame.(The seal air skid for this damper containing the Blowers with Motors, Heater, Isolating valves and all required Instrumentation is in vendor scope of supply and it shall be mounted on platform above the duct. Mounting platform for supporting seal air skid and access ladder alone will be supplied by Purchaser.)
 - (e) Pressure switch with root valve in common line (after junction of 2 x 100% seal air line, refer P&ID 4610-101-05RP)
- 3.4 Leak Tightness Type test(Volumetric flow method) to be conducted on the damper to be supplied for the first unit. Separate Break up price for this type test is to be indicated. (Refer clause no. 12.0)
- 3.5 Erection & Commissioning support. (Refer clause nos. 6.2, 6.3 & 16.0)
- 3.6 Mandatory spares (will be covered separately but vendor to quote with breakup price for the following)
 - (i) 1 set of seals of each type for the damper (Set means complete Replacement for one damper covering total duct cross section area of 72.042 m². In case 2 split dampers of modular design are being supplied to cover the duct area of 72.042 m², vendor has to supply complete set of seals for each of the 2 split dampers.)
 - (ii) 1 number Actuator (Pneumatic cylinder) for the damper

4.0 Working Environment:

The medium of flow in the gate is corrosive Flue gas and the properties of the medium is enclosed in Clause No.23.

5.0 Operational Requirement:

During start up of boiler both gates(FGD Inlet & Outlet)are in closed condition. When the FGD is ready to operate and ID fans are under normal running condition then FGD inlet and outlet gates are opened by control system. After ensuring 100% opening of both inlet and outlet gates through limit switches, the FGD bypass damper is then gradually closed for diverting the flue gas into the FGD plant for treatment. The pressure loss along the FGD is about 300 mm of water column. For taking shutdown maintenance of FGD plant, bypass damper is gradually opened, after ensuring 100 percent opening of bypass damper, both gates are allowed to close.

BHEL will only supply the power and control signals for damper operation. Compressed air at 4.5 kg/cm² (max) will be made available at site. Vendor shall provide details of actuator and its accessories during offer with write up to explain how the adjustable quick opening times are achievable in their offer. Provision of opening damper by hand wheel in case of emergency shall be provided.

Vendor shall submit the Pneumatic hook up diagram (as applicable) showing all accessories in the circuit and provide all important details of actuator and its accessories during Offer. BHEL will only supply the power and control signals for Electro-pneumatic actuator and compressed air and control signals for Pneumatic actuator. Limit switch and Solenoid valves have to be wired to a Terminal box mounted on damper frame by the vendor. All other accessories & inter connecting wiring / tubing are in vendor scope.

5.1 Normal closing of biplane damper with intermittent stop(40%-40%-20%)

After ensuring the opening of FGD inlet and outlet gates, command for closing of bypass damper will be issued manually through Distributed Control System(DCS).

a) On receiving closing command (4-20mA signal) from DCS, the actuator shall rotate up to 40% (36 degree rotation) and then it shall stop. The time of closure may be more than 24 seconds. After the above stoppage, the pressure monitoring system of the boiler is observed. The required pressure difference will be maintained by adjusting the ID fan / Booster fan speed, as applicable if required.

b) If all the pressure readings are normalized, the next closing command to actuator will be issued from DCS for closing (4-20mA signal) of another 40% (36 degree rotation) of bypass damper, The actuator shall stop automatically after reaching the above position. The time of closure may be more than 24 seconds. The pressure level of the boiler is monitored by adjusting the ID fan/ Booster fan speed as applicable.

c) If everything goes well, final command will be issued to actuator from DCS for closing (4-20mA signal) of remaining 20 % (18 degree rotation) of the bypass damper. Since closing of final 20% of bypass damper will cause more pressure variation of the boiler than closing the first / second 40% of the bypass damper, hence close

monitoring and communication for each system is required and more time will be allowed during this period. The time allowed will be more than 12 seconds for final closing in order to maintain the normal pressure level of the boiler by adjusting the ID fans / Booster fans speed as applicable.

5.2 Normal opening of biplane damper :

The sequence of opening will be reverse order of normal closing ie 3steps (20%,40% & 40%)

a) On receipt of Open command from DCS (4-20mA signal), the actuator opens first 20% (18 degree rotation) and then it shall stop. After the above step, the pressure monitoring system of the boiler is observed. The required pressure difference of the boiler will be maintained by adjusting the ID fan/ Booster fan speed as applicable.

b) Secondly, if all the pressure readings are normal, command will be issued from DCS for opening (4-20mA signal) of another 40% (36 degree rotation), then pressure readings are monitored.

c) Command for opening (4-20mA signal) the remaining 40% (36 degree rotation) will be issued to actuator after stabilizing the boiler pressure difference

5.3 Quick opening during emergency:

Quick opening is required to protect the FGD in case any trouble in the FGD equipment and allow the flue gas directly to chimney without affecting the operation of boiler. Actuator shall open the damper completely i.e. from full close to full open positions within 't' seconds without any intermittent stops. (t - the quick opening / closing time of damper should be **adjustable between 10 to 20 seconds** to meet the FGD supplier requirements)

Note : Vendor shall supply electro-pneumatic actuator including all accessories required for proper and safe operation of above damper. BHEL will only supply the power and control signals for damper operation. Vendor shall provide details of actuator and its accessories during offer.

6.0 Design Criteria:

Damper is to be designed to meet the criteria stated below

- Duct inner dimensions 6000mm width x 12007 mm height
- Data sheet for FGD Bypass damper ([DS-57583](#))
- Flue gas property (Clause no. [23.0](#)).

6.1 Modular/Combination of Modular & split design: Damper size being large, it is not possible to dispatch as single piece. Hence **only** modular design or a combination of modular & split design damper shall be supplied. After all applicable testing at vendor's works, this Damper is to be dismantled and packed for transportation. At site, it should be assembled for erection & installing in duct. Vendor has to specify the method of construction & mounting details during the offer.(Refer Clauseno.13.0 & 14.0)

6.2 Site Assembly Scope:

Considering that the Damper is shipped to project site in knocked down condition, site assembly (including consumables for welding / bolting etc. required for making it into a whole assembly), arranging for all necessary manpower for assembling the Damper at site, special tools, special equipment and special temporary attachments as applicable for safe erection on a rental basis are to be arranged by vendor as part of their scope of supply and the Damper is to be erected to the connecting duct by the vendor at site. However the welding of the damper mating flanges to the upstream and downstream connecting ducts and consumables required for welding the mating flanges of Damper to the Connecting ducts are in Purchaser's scope. Vendor is responsible for the erection of Damper in duct and has to estimate the requirements of manpower , their duration at site, the rentals for applicable items required for enabling erection in duct at site and quote suitably.

The above activity has to be done in the first visit i.e. Erection support visit. BHEL will inform the vendor sufficiently in advance when the Erection support (first visit) is required at site. The vendor has to make their own travel to site, boarding and lodging arrangements at / near site during this period including local travel. (Also refer clause 16.0)

6.3 Commissioning support at site:

The vendor has to offer commissioning support at the project site for the offered Damper and its accessories to enable successful completion of all commissioning and operation of applicable interlocks during the second visit of 2 days in site (Commissioning support visit).

BHEL will inform the vendor sufficiently in advance when the Commissioning support (second visit) is required at site.

The vendor has to make their own travel to site, boarding and lodging arrangements at / near site during this period including local travel.

The Bidder has to quote separate Breakup Price lumpsum(including charges of above clause nos. 6.2 and 6.3 meeting requirements of clause no. 16.0) in sl. no. 4 of Proforma Invoice (PI-57583).

7.0 Construction Details:

7.1 Casing:- Casing shall be fabricated to the dimension as per the datasheet with suitable thickness. It shall have a provision for seal air entry duct. Lifting lugs shall be provided for handling. The frame shall be suitably stiffened. Name plate details with Purchase order number, Vendor name, Address & email ID is to be fastened visibly on drive side on the frame. A Blade position indicator shall be mounted on the drive side of casing.

7.2 Locking device: manual locking device shall be provided both at full open and full close positions.

7.3 Blades:-Blades are designed in such a way that it should have deflection resistant configuration and have suitable thickness to withstand the pressure given in the datasheet. Vendor has to specify the blade design in the offer.

7.4 Shaft:- Suitable material shall be selected to withstand the high torque. Vendor has to specify the shaft design, material specification and provision for expansion of the blades.

7.5 Stuffing Boxes: Special external stuffing boxes are to be installed at drive side of the damper casing for tight sealing of the passage of the trunnion (stub shaft) through the damper casing. The stuffing box packing shall not deflect during blade movement or due to thermal expansion and shall remain gas tight. Vendor has to specify their design.

7.6 Bearings:- suitable bearing shall be provided for the shaft (either maintenance free flanged ball bearings or graphite based sleeve bearings) for supporting the trunnion (stub shaft). The bearings are to be designed to avoid jamming of the damper blades even under arduous conditions.

7.7 Sealing System: Alloy C276 or better material seals (based on springback properties) are to be installed on the periphery of the damper blades. Sealing arrangements shall ensure minimum 99.50% sealing efficiency on flow without seal air and 100% with seal air. Seals shall have minimum service life of three years before replacement. The seal fixing arrangement for blade to blade, blade to frame and jamb seal shall be clearly specified in the drawing. The seal and mounting design shall have the facility for easy replacement of seals during maintenance.

7.8 Linkage Mechanism: Vendor to furnish details.

8.0 Material of Construction:-

8.1) The Adjoining duct is made up of S-Ten1 material of 9mm thickness.

8.2) Bypass Damper:

- (a) **Frame:** (For all parts of frame in contact with flue gas)
S-Ten 1 / A36 lined with 5 mm thick SS317LMN or better material / C276 cladding (Refer note regarding cladding below) of sheet thickness 1.6 mm on downstream side. (The alternate better material should have a higher PREN value compared to SS317LMN when calculated using the chemical composition formula
" $PREN = \%Cr + 3.3*\%Mo + 16*\%N$ ")
- (b) **Blade:** (On downstream side of flow i.e. facing Chimney side)
SS317LMN or better material/ C276 cladding of sheet thickness 1.6 mm (Refer Note below).

Note: cladding shall be attached properly to the base to ensure that the base material does not come into contact with the corrosive gases under any circumstance.)

8.3) Seals:- HASTELLOY Alloy C-276 (**ASTMB575 UNSN10276**) or better material based on spring back properties.

8.4) Drive, Slave & Stub shaft: Vendor to specify suitable material for sulphuric acid corrosion resistance.

8.5) Note for Materials offered:

If alternate materials are offered like JIS, DIN etc., other than ASTM indicated in our specification/ datasheet, then vendor has to indicate nearest equivalent ASTM material codes in addition to their offered codes with chemical Composition for our review. (Chinese standard for materials are not acceptable). The alternate materials are to be equal or better than those corresponding specified. . Vendor has to submit justification for these, showing comparison of physical, chemical, strength, spring back property as applicable for the intended part/ service.

9.0 Seal Air system (2 x 100%)

Seal air is required during normal operation of the FGD (Bypass damper is in closed condition) to avoid leaking of upstream side hot flue gas (i.e. from ID Fan duct side) into chimney thereby minimizing atmospheric SO_x pollution. In the outlet of each blower, individual check valve (NRV) is required (Refer P&ID enclosed). **The offered damper design should require seal air only in Damper closed condition and blower and Heater will be switched off when Damper is in open condition.** Seal air system shall consist of blowers with motors, Electrical heater, air operated knife edge gate or butterfly valve with solenoid valve, filter cum regulator and connected piping arrangement (skid mounted) in vendor scope. Vendor to specify the seal air flow, pressure, blower kilo watt rating with the technical offer. The solenoid coil rating shall be 24VDC. Blower selected shall be suitable for 3 phase power supply, 50 Hz & 415V AC. The motors shall be Energy efficient motors, Efficiency class- IE2 conforming to IS12615. (Refer TECI :: LT MOTOR: REV.01 for motor spec of seal air blower). The noise level of Blower with motor at 1.5 meter above floor level & at 1 meter horizontal distance shall not exceed 85dBA. Electrical wiring termination shall be at termination box with double compression type nickel plated brass cable gland with insulated tinned copper crimping lug. Electrical Heater shall be provided to heat the seal air. Vendor shall size the heater suitably to avoid condensation of water vapour on Damper blades, ash deposition, to minimize the thermal differential across the damper and to meet the design criteria.

The electric Heater shall heat the seal air to at least 130°C (The dew point temperature of flue gas)

10 .0 Actuator System for Damper:

Electro Pneumatic actuator for modulation duty with double acting smart positioner. Damper shall have emergency opening on loss of power or pressure and manual hand

wheel over ride. One pair of integral limit switches each shall be provided in the actuator for the Open & Close positions. A continuous 4 – 20 mA position feedback signal shall be provided to enable achieving intermediate opening positions of 40% and 80% as specified in clause 5.1 & 5.2. Also specification requirements of SMART positioner (TDC: TCI: 317/ Rev.02) and Power Cylinder Regulating type (TCI:143 Rev.08) enclosed shall be complied.

11.0 Painting requirements: (Also refer PS VINDHYACHAL R549 REV.00 dt. 16/08/2012 , 1 page 11 of 12)

Power tool cleaning to St3 (SSPC-SP3) followed by

- i) Two coats of Heat resistant aluminum paint Gr. 2 as per IS 13183 with total film thickness of 40 microns for the gate surfaces.
- (ii) Painting is not applicable for stainless steel surface, C276 seals & cladding surfaces

12.0 Quality plan & Testing:

Vender shall submit QUALITY PLAN for approval covering the following:

a) Vender has to submit their QUALITY PLAN (QP) for customer (NTPC) approval. While preparing QP, vendor shall consider BHEL quality requirements as specified in the BHEL quality plan No: **R502/04 dated 30-09-2011** approved by NTPC . The vendor has to follow the same in line with NTPC Manufacturing QP (MQP) taking care of all the applicable clauses and the vendor has to submit the MQP accordingly for NTPC Approval. A sample MQP of a different vendor for a different product is enclosed for reference (1 page) . NTPC will require minimum 3 weeks time to approve the MQP.

b) Vendor has to submit GA drawing of damper assembly showing all important dimensions like overall height, dis-mantlable locations (modules) for shipping. The GA shall include all item details with BOM and material specification. Seal arrangement on all the four sides, blade construction, frame construction & sectional views on all four sides. Actuator location, platform requirement & arrangement for the seal air skid, Seal air entry interface details. Modular details for dispatch. Supplier's drawing should be approved by BHEL / Customer before start of manufacturing by vendor.

c) Detailed test procedure for (i) routine / acceptance test, (ii) Detailed test procedure with test parameters for leak tightness with & without seal air is to be prepared inline with BHEL/Ranipet test procedure No G&D: LTTP and same shall be submitted for customer approval with drawing showing the test set up and sample calculations.

The damper should be tested at manufacturer's works for operation, seal gap measurements and leak tightness without & with seal air to prove the guaranteed sealing efficiency of $\geq 99.5\% \& 100\%$ respectively and report should be submitted. **Vendor shall make their own arrangements for test stand, test equipment like blowers, Actuator, Air tanks and instruments.** The tests will be witnessed by BHEL and customer or their authorized inspection agency. Leak tightness test Report without seal air and with seal air should be submitted and it has to prove the guaranteed sealing efficiency. The damper is to be dispatched only on explicit clearance by BHEL after review of test records.

For testing the leak tightness, seal air at sufficient pressure above the operating pressure is to be supplied to ensure 100% leak tightness. Detailed test procedure for leak tightness testing (G&D: LTTP), 7 pages is enclosed. After Purchase Order is placed, vendor shall

submit their Test Procedure for Leak tightness test for approval. This has to be the same as that required in BHEL enclosure (G&D: LTTP). Alternate testing procedures(Bidder's counter offer) of leak tightness efficiency by surface area method or seal air consumption method as against volumetric flow specified in the test procedure No G&D:LTTP is not acceptable. Vendor has to give 15 days advance intimation for witnessing of leak tightness type test for making travel arrangement. The damper is to be dispatched only on explicit clearance by BHEL after review of test records.

- d) Damper material test certificates and Inspection records.
- e) Damper Open and Close testing using actuator
- f) NDT requirements of the weld.
- g) NTPC Approved painting procedure to be followed.
- h) Quality plan for Pneumatic actuator (QA:CI: STD: QP: 42) enclosed with this specification.
- i) Supplier's drawing should be approved by BHEL before manufacturing.
- j) NTPC format evaluation reports enclosed
 - 1) Format No. QS-01-QAI-P-04 / F1-R2 page 1 of 1 which will be filled up by BHEL and submitted to NTPC. This is for Bidder's information.
 - 2) Format No. QS-01-QAI-P-04 / F2-R1 pages 1 to 7 of 7. This has to be filled up and submitted by Bidder along with Technical offer.

13.0 Packing for dispatch:

Damper and accessories are to be painted and packaged to take care of corrosion due to sea voyage and handling at port & site. Packing has to withstand power station outdoor condition for the period of six months.

Packing shall be done in accordance with General shipping instructions.

Sufficient amount of transport stiffeners are to be welded on all the sides of gate to avoid distortion (if applicable) during transit & handling. Stiffeners should be painted yellow. Description, quantity &weight details of each items have to be neatly marked on each crate. Damper spares shall be packed in a crate separately.

Overall Transportation Limitations for Indian Roads(for guidance)

Width of road transport = 5500 mm maximum

Height of the consignment = 5000 mm maximum

Length of consignment = 20000mm

Weights of the consignment = 40000kg

Vendor shall submit shipping bill of material with packages, identified with overall size, quantity and weight. Overall dimensions shall be as per transport limitations furnished above.

14.0 Qualification Requirement (Offer Acceptance Criteria)

The Bidder to qualify should have engineered and supplied (manufactured by themselves or through their outsourced manufacturers or through their technology licensee) both the following 2 items (a) and (b) :

- (a) A large size Bi-plane damper (tandem louver) meeting the technical requirements of clause 6.1 of this specification for a large duct of at least 50 m² cross sectional area and a width of at least 5m. (All dimensions being internal dimensions of duct. For this purpose duct cross section for this Vindhychal project FGD bypass damper is 72.042 m² i.e. 6m x 12.007m). The damper engineered and supplied for the reference project may be either of the following 2 designs only:
- (i) A single damper assembly dispatched in 3 or more modules (The dismantlable joints being along the damper height) with 1 or maximum 2 pneumatic actuators.
 - (ii) A design combining both Modular and split damper features: A maximum of 2 split dampers vertically one above the other and each split damper having 1 or maximum 2 pneumatic actuators. Further each split damper should mandatorily be of a modular (dismantlable) design dispatched in 2 or more modules is acceptable.
- (b) A Guillotine gate or a Louver/Bi-plane Damper with special materials like SS317LMN / C2205/ 904L if the bidder proposes to supply the same for this FGD Bypass damper (or) a Gate / Louver/Bi-plane damper with C276 cladding for Blades and Frame if C276 is contemplated by the bidder for this project.

The above 2 items (a)(i) / (a)(ii) and (b) should have been erected and completed at least 1 year of satisfactory operation as on date of tender opening. If the Bidder has designed and supplied a Bi-plane damper meeting above 2 conditions (a)(i)/(a)(ii) and (b), then a single reference is sufficient.

(c) The Bidder shall provide their customer reference details for (a) and (b) above showing name of project, date of commissioning and service. Bidder shall also submit General Arrangement drawing for the above showing clearly Bidder / Licensee / Licensor name in title block as applicable, size of damper, BOM for proof of materials for (b) above, Assembled weight and proof that it is of dis-mantlable design as specified in clause no. 6.1 & 14.0 (a)(i) / 14.0(a)(ii).

(d) In case a Licensee is the bidder, the licensee shall furnish a Certificate from the qualified Licensor(meeting the technical requirements of (a) and (b) above, that the bidder is authorized to quote for this project and they will provide the Engineering support to enable the licensee to complete all deliverables indicated in scope of supply clause 3.0, 12.0 and 16.0. Also the reference details and G.A. drawings of the supplies made by the Licensor for (a) and (b) above shall be enclosed.

Non submission of details and back up documents specified in (c) and in the case of a Licensee (c) and (d) above will lead to rejection of Bidder's offer and the same will not be considered for further evaluation.

15.0 Responsibility

The extent of supply stated here in is not necessarily exhaustive and shall not relieve the supplier from his responsibilities to provide goods & services necessary to satisfy

the purchaser's performance criteria & required life, to be complete for installation & to be fit for purpose, safe, reliable, easily maintained and efficient in operation.

Bidder shall make all possible efforts to comply strictly with the requirements of this specification and other specifications/ attachments to inquiry/ order.

In general, deviations are not acceptable. In case, deviations are considered essential by the Bidder (after exhausting all possible efforts), these shall be separately listed in the Bidder's proposal titled as "List of Deviations/ Exceptions to the Enquiry Document". Deviation shall be listed separately for each document with cross reference to Page No./ Para etc. of the respective document supported with proper reasons for the deviation for purchaser's consideration. Any deviation, not listed under the above section, even if reflected in any other portion of the proposal, shall not be considered applicable. No deviation or exception shall be permitted without the written approval of the purchaser.

In case the Bidder considers requirement of additional instrumentation, controls, safety devices and any other accessories /auxiliaries essential for safe and satisfactory operation of the equipment, he shall recommend the same along with reasons in a separate section along with his proposal and include the same in his scope of supply.

16.0 Assistance for Erection & Commissioning:

The Bidder shall quote separate breakup price per diem basis for support to be rendered during erection and commissioning of the damper at the project site. The vendor has to offer erection support in the first visit as indicated in clause no. 6.2 and 2 separate days at site for commissioning in the second visit as indicated in clause no. 6.3. Payment will be made on certification by site engineer on satisfactory completion of both the erection and commissioning support. The vendor has to make their own travel to site, boarding and lodging arrangements at / near site during this period including local travel.

The Bidder has to quote separate Price lumpsum(including charges of above clause nos. 6.2 and 6.3 in sl. no. 4 of Proforma Invoice (PI-57583). Bidder shall indicate lumpsum value and not give counter offer by indicating travel, accommodation, man hour / man day, rental costs etc. in PI-57583.

17.0 Spares:

The Bidder shall offer for the following.

- a. Commissioning spares –Quantity with per unit rate
- b. Recommended spares for 3 years operation – Quantity with per unit rate

The above commissioning & Recommended spares will not be included for price comparison between vendors. BHEL reserves the option of procuring any or all of these at a later stage. Prices are to be valid for a period of period of 3 years from offer submission stage.

Vendor has to quote for the Mandatory spares indicated in PI-57583.

18.0 Special Tools:

The Gates shall be designed to be assembled, disassembled and maintained with standard hand tools. However, if at all the vendor desires special tools are required, the same has to be supplied along with the Gate. List of special tools if applicable is to be brought out clearly in " SCOPE OF SUPPLY".

19.0 Instrumentation in Vendor's Scope of supply: (Refer P&ID:4610-101-05RP)

- Local Pressure gauge with isolating root valve upstream of Heater.
- 1 Pressure switch in common Pneumatic line downstream of seal air blowers with isolating root valve.
- Flow switch for Heater protection (connection to FGD DCS by Purchaser)
- Seal Air Heater (3 ph, 415V, 50Hz. Should withstand a variation of $\pm 10\%$ in Input voltage, $\pm 5\%$ in frequency and a combined variation of $\pm 10\%$ and designed for continuous operation.) Control panel is in NTPC scope of supply.
- Temperature switch for Heater Protection (connection to FGD DCS by Purchaser)
- Temperature Transmitter for Heater Protection (connection to FGD DCS by Purchaser)
- Local control panel for mounting valves, pneumatic fittings & signal cables required for Pneumatic circuitry of damper for achieving Quick opening & normal timings in clause 5.1 & 5.2.
- Air tank (Air receiver), Pressure indicator, root valves, drain valves, safety relief valve, double acting smart positioner, pressure switch & solenoid valves for achieving emergency quick opening during loss of electrical or pneumatic signal are in vendor scope.

The Instrumentation / control cables for all the above instruments are to be terminated in Field Junction boxes to be supplied in vendor scope.

The above are in addition to other items specified in clause no. 3 – Scope of supply. Instrument air will be provided at a pressure of $4.5 \text{ kg /cm}^2(\text{g})$ for the pneumatic operation of the isolating valve in seal air line. The exact air regulator setting to be furnished by the vendor. Also for the pneumatic actuator of the isolating valve, Instrument air requirements in $\text{m}^3/\text{sec} \times \text{__ sec}$ (duration of open / close time) to be furnished by vendor. BHEL will only supply the power and control signals for Damper operation. All accessories & interconnection wiring / tubing and other instrumentation are in vendor scope.

20.0 (A) Auxiliary Power consumption:

The Bypass damper will be in Open condition when FGD is not in service and Damper blades will be in Closed condition when FGD is in service. When Damper is in closed condition, heated seal air will be supplied to the hollow volume of the damper blades by switching on the blower and heater. When the damper is open, the heater & blower will be switched off.

The design and material selection of all the Damper components is to be done such that when the FGD is not in operation (i.e. Damper Blades are in open condition), the Electrical heater and seal air blower will be switched off and no component of the Damper shall be corroded. All materials including Frame, blades, shaft and other internals exposed to Flue gas to be taken care to prevent sulfuric acid corrosion when Damper is in open condition. Vendor has to confirm in Check list enclosed that the heater and Blower can be switched off when Blade is in open condition. (This will minimize auxiliary power consumption to end user).

When the FGD is in operation (i.e. Damper Blades are in closed condition), the auxiliary power consumption of heater is estimated at 352 KW considering the Ambient air temperature of 27 deg C & 60% Relative humidity and heated to 130 deg C. The seal air blower power consumption is estimated as 45 KW for FGD in operation. **The total auxiliary power consumption in FGD mode is 397 KW(i.e. 352 + 45).** In the technical offer, if the bidder's power consumption in FGD mode exceeds 397 KW, a price loading @ Indian Rupees 2,25,000/- **per KW increase above 397 KW** will be added to the vendor's quoted price for price comparison purpose between different vendors. Hence bidder shall consider auxiliary power consumption values carefully for equipment selection. However bonus / preference is not applicable if the vendor's quoted auxiliary power consumption is less than 397 KW.

(B) Operating pressure for this Damper in mm WC:

Upstream side of Damper : Duct from ID Fan outlet (Refer Key plan drg in Clause 22.0)

Downstream side of Damper : Duct to Chimney

	When Damper open	When Damper closed
Upstream pressure mm WC Upstream Temp deg C	10 to 40 approx 130 to 145	10 to 40 approx 130 to 145
Downstream Pressure mm WC Downstream Temp deg C	10 to 40 approx 130 to 145	10 approx 100 to 105 deg C

21.0 DOCUMENTS:

Vendor shall submit the following documents and drawings in English

21.1 Documents to be submitted along with Offer.

Sl.no:	DOCUMENTS	Vendor Acceptance comments/
1	(i) Comments/deviation for the Specification No. GDRS 018 & related enclosures (ii) Filled up Data sheet for Damper: DS-57583 (iii) Sketch of Pneumatic circuitry and write up explaining how the timings specified in clause 5.0, 5.1 & 5.2 are proposed to be achieved (iv) Filled up Proforma Invoice (Un-Priced Price Bid) : PI-57583 (v) Filled up Checklist : CL-BL-57583	
2	General arrangement drawing with dimensions showing location of Accessories like Blower, Heater, Isolation valve, Actuator, Air Receiver, BOM & Weight.	
3	Vendor quality plan for review (should be in line with BHEL Quality Plan)	
4	Recommended spares list for commissioning & three year operations	
5	Reference list & documents of FGD Bypass damper– (as per Clause no.14.0) to prove Qualification Requirement	
6	Vendor confirmation for all documents submission in 21.2 , 21.3 & 21.4 for approval as specified after placement of purchase order	
7	Draft Erection & Commissioning Procedure applicable for the offered design and scope of supply.	

21.2 Vendor shall submit the following Documents for BHEL approval within 30 days after placing Purchase Order. Only after BHEL Approval, vendor can commence manufacturing activity.

SINo	Documents	No Copies required	Vendor acceptance comments / deviation
1	Revised Quality plan(if any)	1	
2	Test Setup & procedure for Leak tightness test	1	

3	Final Damper Datasheet	1	
4	Finalized details with make & model nos. for Air cylinder, Smart positioner, Instrumentation, local control panel etc.	1	
5	Basic engineering transmittal for approach and platform for maintenance	1	
6	G.A Dimensions and Mounting details of Damper and its Accessories, End to end dimensions of Damper with mating flanges, Skid mounting details / Layout arrangement of seal air skid (To enable BHEL design & supply platform for skid mounting & ladder for access), P&IDs, Power & Control schemes	1	

21.3 Documents to be submitted before dispatch

Sl. No.	Documents	No Copies required	Vendor acceptance comments / deviation
1	Complete inspection/ test records of Dampers & accessories.	2	
2	Leak test results with & without seal air	2	
3	Raw material Test Certificates	2	
4	Packing drawing & specification	2	
5	Erection drawing & Erection manual(in English for Damper, Actuator & all accessories)	3	
6	Protection / Interlocks, Operating Procedures / Trouble shooting & Maintenance etc.	3	

21.4 Documents to be submitted along with Dispatch

Sl. No.	Documents	No Copies required	Vendor acceptance comments / deviation
1	Shipping list / supply schedule	3	
2	List of spares dispatched	3	
3	O&M manual (in English for Damper, Accessories & Instrumentation)	3	

22.0 Key plan drawing of the FGD Gates & By pass Damper

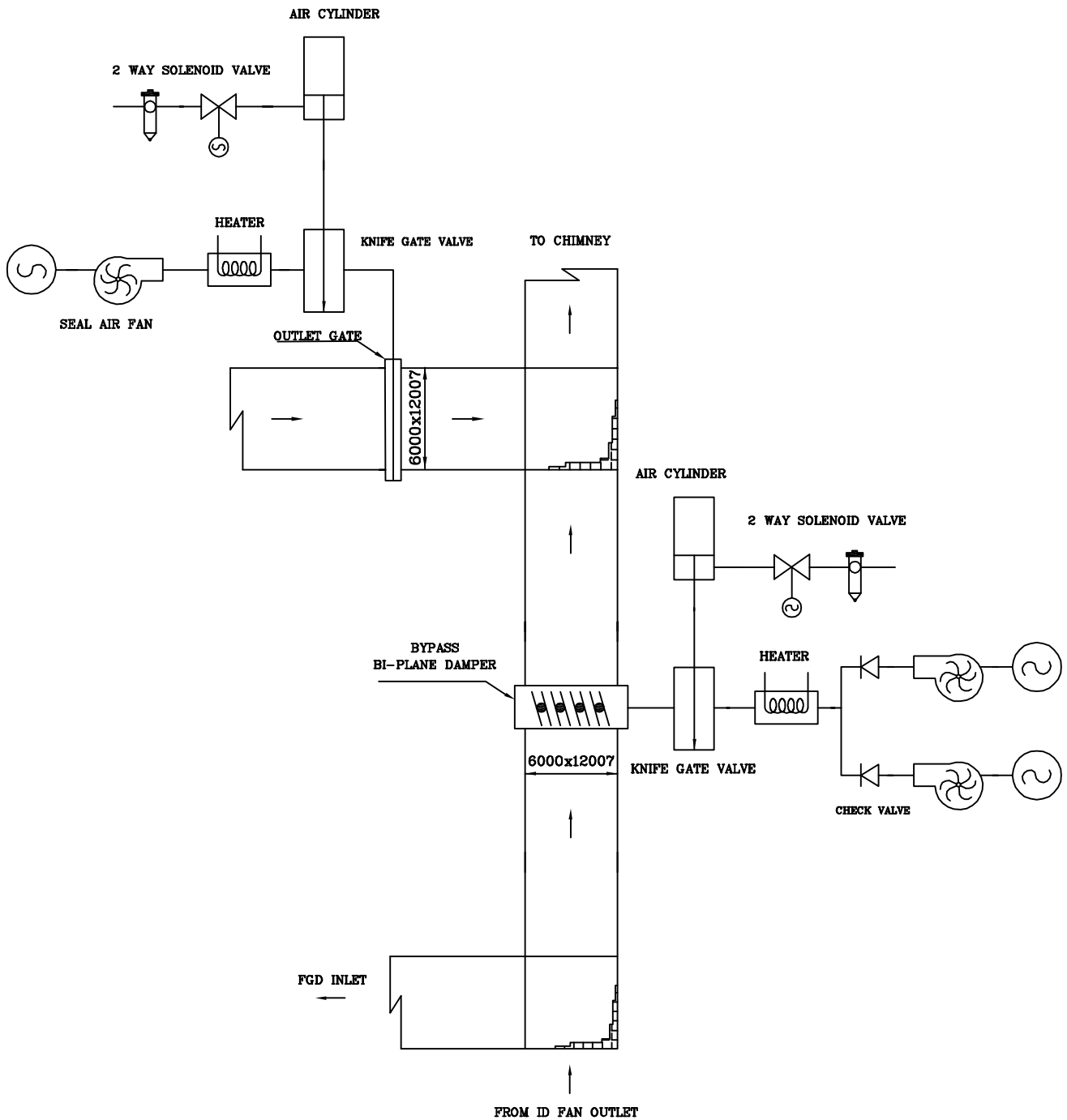

23.0 FLUE GAS Property

SI.No	Item Description	Unit	Values (Worst coal)
01	Inlet dust concentration to FGD	mg/Nm ³	50 - 200
02	SO ₂ concentration at FGD inlet gate	mg/Nm ³	GP -1912 DP -1852
03	SO ₂ concentration at FGD outlet gate	mg/Nm ³	GP – 180 DP - 178
04	Flue gas flow through Gate / Damper	Nm ³ /s	GP – 565.6 DP – 643.3
05	Density of flue gas	Kg/m ³	0.784
06	Inlet SO ₂	%(byvol)	0.07
07	SO ₃	%	1.5% (conversion from SO ₂)
08	SO ₂ removal efficiency	%	GP – 90.6 DP – 90.4
09	Moisture (wet basis)	%(by vol)	GP – 13.61 DP – 16.06
10	Flue gas temperature at FGD inlet	Deg. Centigrade	GP – 125 DP - 145
11	Flue Temperature of gas at FGD outlet gate	Deg. Centigrade	100
12	Ambient Air temperature	Deg. Centigrade	GP – 27 DP - 42
13	Relative humidity	%	60

Note: GP : Guarantee Point ; DP – Design Point

The Leak tightness type test is to be done for the Design Point parameters indicated.

NOTE: -

- (1). QTY SHOWN FOR 1(ONE) SYSTEM. TOTAL OF 1(ONE) SYSTEM REQUIRED.
- (2). DAMPER IS WITH PNEUMATIC CYLINDER & SMART POSITIONER.

PIPE LINE SYMBOLS: -



- FLUE GAS DUCT LINE
- SEAL AIR LINE
- INSTRUMENT AIR OR PNEUMATIC SIGNAL
- INSTRUMENT PROCESS PIPING OR CONNECTION TO PROCESS
- HYDRAULIC LINE
- ELECTRICAL SIGNAL
- MECHANICAL LINK
- BATTERY LIMIT SUPPLIER/CUSTOMER

△01 LEGEND: -

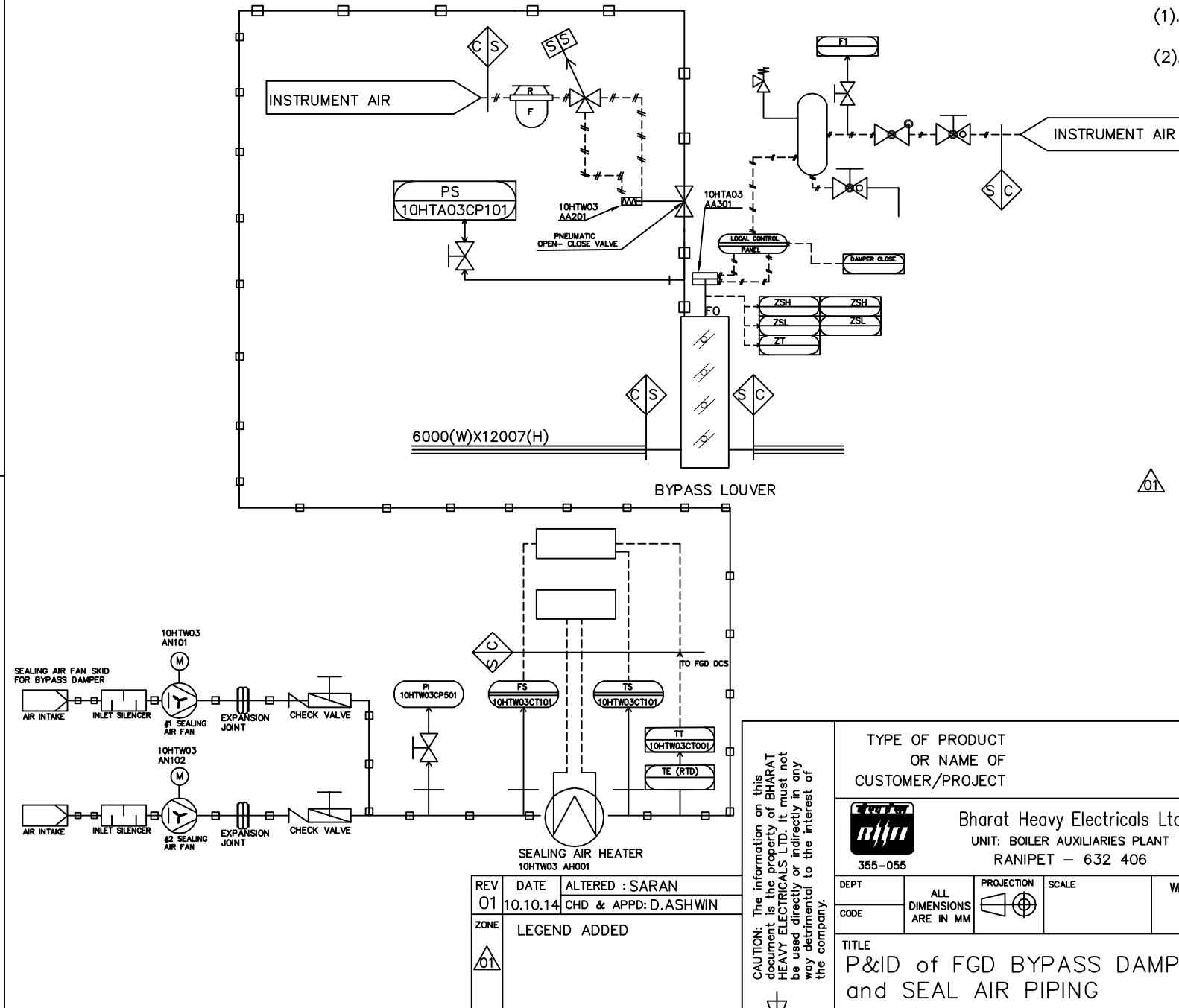
- PS - PRESSURE SWITCH
- PI - PRESSURE GAGE/ INDICATOR
- FS - FLOW SWITCH
- TS - TEMPERATURE SWITCH
- TT - TEMPERATURE TRANSMITTER
- TE - RTD
- RF - AIR FILTER REGULATOR
- SS - DUAL COIL SOLENOID VALVE

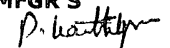

CAUTION: The information on this document is the property of BHARAT HEAVY ELECTRICALS LTD. It must not be used directly or indirectly in any way detrimental to the interest of the company.		TYPE OF PRODUCT OR NAME OF CUSTOMER/PROJECT			
		Bharat Heavy Electricals Ltd UNIT: BOILER AUXILIARIES PLANT RANIPET - 632 406 355-055		DRN NAME NEELA	SIGNATURE
DEPT CODE		ALL DIMENSIONS ARE IN MM		PROJECTION 	SCALE
TITLE P&ID of FGD BYPASS DAMPER and SEAL AIR PIPING		WEIGHT (Kg)		REF TO ASSY / OLD DWG	
REV 01 DATE 10.10.14 ALTERED : SARAN CHD & APPD: D.ASHWIN		ZONE LEGEND ADDED		DRAWING NO : 4610-101-05RP 01	

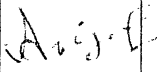
 Ranipet	MANUFACTURER'S NAME AND ADDRESS M/S BHEL RANIPET 632 406 TAMIL NADU	ITEM /EQUIPMENT: G&D SUB-SYSTEM: DAMPERS	Q.P NO	R502	SIGN. OF MFGR'S  P. KARTHIKEYAN MANAGER / QA	TO BE FILLED BY NTPC								
			REV / DATE	04/30 09 11		QP NO.:	0000-999-QVM-P-268	REVIEWED BY 	APPROVED BY 					
			PAGE NO	1 OF 4		REV NO/DATE	03/ DT 30092011							
						PAGE NO.:	1 of 4							
				VALID UP TO	29.09.2014									
SL. NO	COMPONENT & OPERATIONS	CHARACTERISTICS	CLASS	TYPE OF CHECK	QUANTUM OF CHECK		REFERENCE DOCUMENT#	ACCEPTANCE NORMS	FORMAT OF RECORD	AGENCY			REMARKS	
					M	C/N				M	C	N		
1.	2.	3.	4.	5.	6.		7.	8.		D	** 10.			11.

1.0	Raw Material												
1.1	Plates, Rolled Sections.	Chemical & Mechanical Properties	Major	TC Verification	100%	@@	Material specification as per GMS	TC		P	V	V	
		Soundness (UT)#	Critical	TC Verification	100%	@@	ASTM A 435	TC	√	P	V	V	
1.2	Rounds	Chemical & Mechanical properties	Major	TC Verification	100%	@@	Material specification as per GMS	TC		P	V	V	
		Soundness (UT) #	Critical	TC verification	100%	100%	ASTM A 388/AM 203.2 of ASME Sec VIII Div.2	TC	√	P	V	V	
1.3	Seals to ASTM B575 UNS N10276 ##	Chemical & Mechanical properties	Major	TC verification	100%	##	As per TDC: 304 Rev.00	TC		P	V	V	
1.4	Sub deliveries	Conformance to PO	Major	Review of Documents	100%	100%	Note 3	TC		P	V	V	

TC - Test Certificate

@@

- > Specification of material referred in QP is indicative only. Actual material shall be as per GMS.
- > Review of material TCs shall be for plates above 40 mm thickness only. For plates of thickness less than or equal to 40 mm, COC will be submitted by BHEL to NTPC.
- > TC verification of channels of size 400 mm and above (if applicable) and Beams of Size 450,500 and 600 mm.
- > # Plates of thickness more than 40 mm and Rounds of Dia. more than 50 mm shall be UT tested.
- > ## Surveillance checks of TC verification will be carried out at Raw materials stores.

LEGEND: * RECORDS, IDENTIFIED WITH "TICK" (√) SHALL BE ESSENTIALLY INCLUDED BY SUPPLIER IN QA DOCUMENTATION.
**** M:** MANUFACTURER/SUB-SUPPLIER **C:** MAIN SUPPLIER, **N:** NTPC **P:** PERFORM **W:** WITNESS **V:** VERIFICATION. AS APPROPRIATE, **CHP:** NTPC SHALL IDENTIFY IN COLUMN "N" AS 'W'

Note: # NTPC Inspection Engineer to check, Approval Date/Revision No .of reference documents at the time of inspection

Format No.: QS-01-QAI-P-10/F1-R1



ENGG, DIV, /QA&I

 Ranipet	MANUFACTURER'S NAME AND ADDRESS M/S BHEL RANIPET 632 406 TAMIL NADU	ITEM /EQUIPMENT: G&D SUB-SYSTEM: DAMPERS	Q.P NO	R502	SIGN. OF MFGR'S <i>P. Karthikeyan</i> P. KARTHIKEYAN MANAGER / QA	TO BE FILLED BY NTPC							
			REV / DATE	04/30 09 11		QP NO.:	0000-999-QVM-P-268	REVIEWED BY <i>[Signature]</i>	APPROVED BY <i>[Signature]</i>				
			PAGE NO	2 OF 4		REV NO/DATE	03/ DT 30092011						
						PAGE NO.:	2 of 4						
				VALID UP TO	29.09.2014								
SL. NO	COMPONENT & OPERATIONS	CHARACTERISTICS	CLASS	TYPE OF CHECK	QUANTUM OF CHECK		REFERENCE DOCUMENT#	ACCEPTANCE NORMS	FORMAT OF RECORD	AGENCY			REMARKS
					M	C/N				M	C	N	
1.	2.	3.	4.	5.	6.		7.	8.		D	** 10.		11.

2.0	In Process Control	Welders are qualified to AWS D 1.1 procedures are pre qualified & NTPC will review procedures and welders qualification records											
2.1	Weld Inspection	Weld Quality & Size	Major	Visual & Measurement	100 %	100%(C) 10% (N)	Note - 1	Report		P	W	V	
2.2	Welds of stud with gland plate & Butt Welds of Frame	Weld soundness	Major	MPI / LPI	100%	100%	BHE: NDT: RP: MT01/02 BHE: NDT: RP: PT01/02	Report	√	P	W	W	
2.3	Welds of Blade Block & all other welds	Weld soundness	Major	MPI / LPI	100%	10%	-DO-	Report	√	P	W	V	
2.4	Assembly	Overall Dimensions & Match marks	Major	Measurement	100%	100%	Drawing	Report		P	W	V	
3.0	Final Inspection												
3.1	Trial Operation	Free Operation	Major	Open/close Movement	100%	100%	Drawing & Note 2 (g)	Report		P	W	W	
		Seal tightness	Major	Check with feeler gauge	100%	100%	-DO-	Report	√	P	W	W	
3.2	Performance Leak Tightness Test (For Bi plane damper only)	Leak Tightness (as per contract)	Major	Performance Test	Refer Test Schedule	Refer Test Schedule	NTPC Engg approved test procedure & Damper test schedule & # Witness by NTPC Engg	Report	√	P	W	W	#
									√				

LEGEND: * RECORDS, IDENTIFIED WITH "TICK" (√) SHALL BE ESSENTIALLY INCLUDED BY SUPPLIER IN QA DOCUMENTATION.
 ** M: MANUFACTURER/SUB-SUPPLIER C: MAIN SUPPLIER, N: NTPC P: PERFORM W: WITNESS V: VERIFICATION. AS APPROPRIATE, CHP: NTPC SHALL IDENTIFY IN COLUMN "N" AS 'W'

Note: # NTPC Inspection Engineer to check, Approval Date/Revision No. of reference documents at the time of inspection

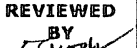
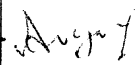
 Ranipet	MANUFACTURER'S NAME AND ADDRESS M/S BHEL RANIPET 632 406 TAMIL NADU	ITEM /EQUIPMENT: G&D SUB-SYSTEM: DAMPERS	QP NO	R502	SIGN. OF MFGR'S  P. KARTHIKEYAN MANAGER / QA	TO BE FILLED BY NTPC							
			REV / DATE	04/30 09 11		QP NO.:	0000-999-QVM-P-268	REVIEWED BY 		APPROVED BY 			
			PAGE NO	3 OF 4		REV NO/DATE	03/ DT 30092011	PAGE NO.: 3 of 4					
						VALID UP TO	29-09-2014						
SL. NO	COMPONENT & OPERATIONS	CHARACTERISTICS	CLASS	TYPE OF CHECK	QUANTUM OF CHECK		REFERENCE DOCUMENT#	ACCEPTANCE NORMS	FORMAT OF RECORD	AGENCY			REMARKS
					M	C/N				M	C	N	
1.	2.	3.	4.	5.	6.		7.	8.		D	** 10.		11.

3.3	Verification of completion	Overall dimensions, orientations,	Major	Verification & Visual	100%	100%	As per drawing All identified by "✓" "under D" in QP	Report	✓	P	W	V	
3.4	Painting, Preservation & Protection	Finish	Minor	Visual	100%	10%	Drawing	Report		P	W	V	
		Paint DFT	Major	Measurement	Random	Random	As per NTPC approved painting scheme	Report		P	W	V	

NOTE 1: VISUAL INSPECTIONS



- a) Visual inspection of welds shall be performed after completion of welding and subsequent cooling to room temperature.
- b) All welds shall be cleaned to remove slag, spatter etc and visually examined for defects like crack, undercut, porosity, lack of fusion etc.
- c) The welds shall also be examined for size, shape and re-enforcement.

Nature of defects	Acceptance Norms	Disposition
Crack, lack of fusion, overlap	Not accepted Repair and retest.	Confirm by LPI/MPI.
Crater	Not accepted	Fill by weld deposit
Undercut	Up to 0.8 mm accepted. >0.8 mm not accepted	----- Fill and grind smooth
Porosity for butt/fillet welds	One pore of dia < 2.4 mm every 100 mm length is permitted. However pores of dia > 2.4 mm not accepted.	----- To be repaired.

Weld contour

1.Face of fillet	Flat or concave accepted. Slightly convex also accepted provided convexity < 0.1 S + 1.5 mm where S is fillet size.
2. Size (Minimum)	As per drawing. Under size permitted up to 1.5 mm for a cumulative length of 10% of total length.
3 Re-enforcement	Max 3 mm up to 19 mm, Max 5 mm above 19 mm.

LEGEND: * RECORDS, IDENTIFIED WITH "TICK" (✓) SHALL BE ESSENTIALLY INCLUDED BY SUPPLIER IN QA DOCUMENTATION.
 ** M: MANUFACTURER/SUB-SUPPLIER C: MAIN SUPPLIER, N: NTPC P: PERFORM W: WITNESS V: VERIFICATION. AS APPROPRIATE, CHP: NTPC SHALL IDENTIFY IN COLUMN "N" AS 'W'
 Note: # NTPC Inspection Engineer to check, Approval Date/Revision No .of reference documents at the time of inspection

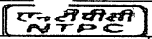
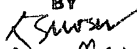
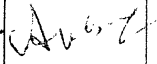
 Ranipet		MANUFACTURER'S NAME AND ADDRESS M/S BHEL RANIPET 632 406 TAMIL NADU		ITEM /EQUIPMENT: G&D SUB-SYSTEM: DAMPERS		QP NO	R502	SIGN. OF MFGR'S  P. KARTHIKEYAN MANAGER / QA	 TO BE FILLED BY NTPC					
						REV / DATE	04/30 09 11		QP NO.:	0000-999-QVM-P-268	REVIEWED BY		APPROVED BY	
						PAGE NO	4 OF 4		REV NO/DATE	03/ DT 30092011	BY 		BY 	
									PAGE NO.:	4 of 4	AGENCY		REMARKS	
		VALID UP TO	29.09.2014	M	C	N								
SL. NO	COMPONENT & OPERATIONS	CHARACTERISTICS	CLASS	TYPE OF CHECK	QUANTUM OF CHECK		REFERENCE DOCUMENT#	ACCEPTANCE NORMS	FORMAT OF RECORD					
					M	C/N								
1.	2.	3.	4.	5.	6.		7.	8.		D	** 10.	11.		

NOTE 2: DAMPER FINAL INSPECTION:-

- a) Dampers shall be tested in site orientation position. Proper support shall be provided and Damper shall be leveled by water level.
- b) Ensure that all components are installed and inspected.
- c) Damper shall be operated in through ten cycles.
- d) The Gap between the blades and blade jamb seals shall be checked using feeler gauge .The readings of gap shall be recorded.
- e) Bulb seals shall be tightened fully after setting the gap.
- f) After the completion of the test, Damper shall be visually inspected for, any damages to blades. Seals etc.
- g) Trial operation of Louver and Bi-plane damper (i.e., open/close) shall be carried out with job actuator or with equivalent actuator i.e., approved make, same type, size & rating and for control damper (i.e., open / close) shall be carried out with equivalent dead weight as per torque requirement of power cylinder.

NOTE 3: SUB DELIVERIES :-

- a) For electrical actuator refer the NTPC approved CQP.
- b) For all other items like blower with motor, actuator nylon bush, shaft collar, graphite filament packing, Graph oil bearings, Tee union, Male connecter and fasteners etc. Rfer the categorization list finalized with NTPC.BHEL will inspect as per Specification and dispatch.

RECORD OF REVISIONS

Record of revision	Revision Number	Date	Basis for change
	00	19 04 2003	Original Issue
	01	30 09 2004	Revised based on discussion with NTPC minutes of meeting Dated 11 09 04
	02	24 01 2005	Revised based on NTPC comments (Format Modified)
	03	17 05 2008	NO change in the RQP. Revised for extension of the Validity period only.
	04	30 09 2011	Note 1 details included in main QP under clause 2.0 and other notes re-numbered and re-submitted for validity date extension

LEGEND: * RECORDS, IDENTIFIED WITH "TICK" (✓) SHALL BE ESSENTIALLY INCLUDED BY SUPPLIER IN QA DOCUMENTATION.
 ** M: MANUFACTURER/SUB-SUPPLIER C: MAIN SUPPLIER, N: NTPC P: PERFORM W: WITNESS V: VERIFICATION. AS APPROPRIATE, CHP: NTPC SHALL IDENTIFY IN COLUM "N" AS 'W'

Note: # NTPC Inspection Engineer to check, Approval Date/Revision No .of reference documents at the time of inspection

	MANUFACTURER:	MANUFACTURING QUALITY PLAN		PROJECT: NTPC BHAR STP STAGE 2 UNIT 1 & 2
	M/S ECE INDUSTRIES LIMITED A-20, INDUSTRIAL AREA, MEERUT ROAD, GHAZIABAD- 201 001	ITEM : ELEVATOR	QP NO.: MQP 1963/1964 R0 REV.NO.: 0 DATE: 30/04/2013 PAGE: 1 OF 9. JOB NO. : SBA 1963 71964	PACKAGE: ESP CONTROL ROOM PACKAGE CODE : P O NO. : 4223230 DATED 01/03/2013 MAIN SUPPLIER : BHEL RANIPET

SL. NO	COMPONENT & OPERATIONS	CHARACTERISTICS	CLASS	TYPE OF CHECK	QUANTUM OF CHECK		REFERENCE DOCUMENT	ACCEPTANCE NORMS	FORMAT OF RECORD	AGENCY			REMARKS
					M	C/N				M	C	N	
1.	2.	3.	4.	5.	6.		7.	8.	9.	D*	**	10.	11.
1	CASTING (A) TRACTION SHEEVE GRADE - FG 350	VISUAL DIMENSIONAL HARDNESS CHEMICAL MECHANICAL	MAJOR " " " "	VISUAL MEASUREMENT MEASURE ANALYSIS ANALYSIS	100% 100% 1/HEAT 1/HEAT 1/HEAT		ECE STD ECE STD IS 210/APD DRG IS 210/APD DRG IS 210/APD DRG	ECE STD ECE STD IS 210/APD DRG IS 210/APD DRG IS 210/APD DRG	MTC MTC MTC	√ √ √	P P V V V	V V V V V	
	(B) OVERSPEED GOVERNOR WHEEL GRADE -FG 200	VISUAL DIMENSIONAL S CHEMICAL MECHANICAL HARDNESS	MAJOR " " " "	VISUAL MEASUREMENT ANALYSIS ANALYSIS MEASURE	100% 100% 1/HEAT 1/HEAT 1/HEAT		ECE STD ECE STD IS 210/APR DRG IS 210/APR DRG IS210/APR DRG	ECE STD ECE STD IS 210/APR DRG IS 210/APR DRG IS210/APR DRG	MTC MTC MTC	√ √ √	P P V V V	V V V V V	
	© DIVERTOR PULLY GRADE -FG 200	VISUAL DIMENSIONAL CHEMICAL MECHANICAL HARDNESS	MAJOR " " " "	VISUAL MEASUREMENT ANALYSIS ANALYSIS MEASURE	100% 100% 1/HEAT 1/HEAT "		ECE STD/ ECE STD IS 210/APR DRG IS 210/APR DRG "	ECE STD ECE STD IS 210/APR DRG IS 210/APR DRG "	MTC MTC MTC	√ √ √	P P V V V	V V V V V	

	MAIN-SUPPLIER	LEGEND: * RECORDS, IDENTIFIED WITH "TICK" (√) SHALL BE ESSENTIALLY INCLUDED BY SUPPLIER IN QA DOCUMENTATION ** M: MANUFACTURER/SUB-SUPPLIER C: BHEL/BHEL NOMINATED AGENCY. N NTPC P: PERFORM W WITNESS AND V: VERIFICATION AS APPROPRIATE, R REVIEW IR INSPECTION REPORT MTC MANUFACTURERS TEST CERTIFICATE CHP: NTPC SHALL IDENTIFY IN COLUM "N" AS "W"	FOR NTPC USE	DOC. NO.:	REV..... CAT.....
	SIGNATURE			REVIEWED BY	APPROVED BY

FORM NO. QS-01-QAI-P-09/F1-R1

I/1 ENGG. DIV./QA&I





MAIN CONTRACTOR'S EVALUATION REPORT
(For Proposed Sub-Supplier)

1. MAIN CONTRACTOR : _____ : M/S _____

2. PACKAGE & PROJECT NAME : _____

3. BRIEF SPEC. OF EQUIPMENT / ITEM / _____ : _____
PROCESS WITH MODEL / TYPE/ RATING /
CAPACITY/ SIZE/ TONNAGE ETC. (AS
APPLICABLE)

4. PROPOSED SUB-SUPPLIER'S _____ : _____
NAME & WORKS ADDRESS

5. BASIS OF RECOMMENDATIONS:

a) Main contractor's own supply experience

REFERENCE LIST (EXPERIENCE FOR THE PARTICULAR TYPE OF EQUIPMENT / ITEM /PROCESS) OF MAIN CONTRACTOR:

CUSTOMER NAME, PROJECT NAME	TYPE / RATING / MODEL/ CAPACITY/ SIZE / TONNAGE ETC (AS APPLICABLE)	SUPPLIED QUANTITY	DATE OF SUPPLY	NO. OF YEARS IN OPERATION/ DATE OF COMMISSIONING (*)

b) In absence of own supply experience:

ENCLOSE MAIN CONTRACTOR'S ASSESSMENT REPORT AS PER THEIR VENDOR APPROVAL SYSTEM ()**

NAME : _____ DESIG. : _____ SIGN : _____ Date: _____

List of Encl.: (Pl. Tick)

(*) a. User Certificate

(**) b. Self Assessment Report



SUB-SUPPLIER QUESTIONNAIRE
(To be filled in by the Proposed Sub Supplier)

Name of Equipment / Item / Process with Model/ Type/ Rating / Capacity/ Size/ Tonnage etc. (As applicable):

Trade Name of Product (if any) : _____

1. Name of Proposed Sub-Supplier: _____

Website: _____

2. Address of Regd. Office:

Details of contact person:

Name _____

Mobile no. _____

Desig. _____

E-mail:

3. Branch/ Liaison office in Delhi/NCR

Details of contact person:

Name _____

Mobile no. _____

Desig. _____

E-mail:

Weekly off day _____

4. Address of Works where Item is being manufactured

Details of contact person:

Name _____

Mobile no. _____

Desig. _____

E-mail:



SUB-SUPPLIER QUESTIONNAIRE
(To be filled in by the Proposed Sub Supplier)

5. Details of Proposed Works:

- a. Year of Establishment of present works : _____
- b. Year of Commencement of Manufacturing at the above works : _____
- c. Details of change in works address in past, if any : _____
- d. Total Area / Covered Area : _____
- e. Details of covered area like no. of sheds, Area of each shed etc. _____
- f. Electric power- Connected load: _____
Electric power- Stand by load & system: _____

6. Annual Turnover & Profit in past three years : _____

7. Do you have in-house Department for:

- a) Design Yes/No
- b) Research & Development Yes/No
- c) Quality control/Inspection Yes/No
- d) After Sales Service Yes/No

8. Shift works per day One/Two/Three

9. Present Manpower Status:

Division Status	Graduate		Diploma	Skilled	Un-Skilled	Remarks
	Technica I	Non-Technical				
Design						
Production						
Quality Control/ Inspection						
After Sales Service						



SUB-SUPPLIER QUESTIONNAIRE
(To be filled in by the Proposed Sub Supplier)

- a. Organization chart of the proposed works is enclosed as Annexure: _____
- b. Organization chart of QA / QC Deptt. is enclosed as Annexure: _____
- c. List of Qualified Welders with process etc. is enclosed as Annexure: _____
- d. List of Qualified NDT personnel with area of specialization is enclosed as Annexure: _____

10. Brief details of items manufactured:

Sl. No.	Item & Material (Type/Size/Rating/Model/ Capacity /Tonnage , as applicable)	Installed Capacity	Annual Production Capacity	Annual Production for last Three years		
				I	II	III

11. Details of foreign Collaboration, if any:

Sl. No.	Product	Name & Address of Collaborator	Collaboration		
			Scope	Year	Valid upto

12. **Type Test report for the proposed product (similar or higher rating)if applicable is enclosed as Annexure: _____**
13. **Approval / Certification by National / International standards / Accredited agency for the proposed product (if applicable) is enclosed as Annexure: _____**
14. **Statutory / mandatory certification for the proposed product (if applicable) is enclosed as Annexure: _____**
15. **Supply Experience list of the proposed product (similar or higher rating) is enclosed as Annexure: _____**

[List shall include Item description, (Type/Size/Rating/Model/Capacity/Tonnage, as applicable), Customer name, Quantity, Year of Supply and Year of commissioning]



SUB-SUPPLIER QUESTIONNAIRE
(To be filled in by the Proposed Sub Supplier)

16. **End User's operational feedback certificate for the proposed product is enclosed as Annexure: _____**

17. **List of equipment & machinery specific to the proposed product is enclosed as Annexure: _____**

(List shall include name of equipment, capacity & nos. etc.)

18. **Process Flow Diagram indicating in-house & outsourced process enclosed as Annexure: _____**

19. **General manufacturing facilities available in-house:**

Sl. No.	Description of machine	Type /Capacity / Size / Rating etc as applicable	Number
a)	Material Handling Mobile Crane Fork Lift Over Head Cranes		
b)	Metal Cutting & Bending		
c)	Casting		
d)	Forging		
e)	Fabrication		
f)	Welding		
g)	Machining		
h)	Heat Treatment		
i)	Surface Cleaning Sand Blasting Shot Blasting Pickling		
j)	Painting		
k)	Metal Coating		



SUB-SUPPLIER QUESTIONNAIRE
(To be filled in by the Proposed Sub Supplier)

l)	Packing		
m)	Other, if any		

20.

a. Inspection & Testing Facilities available in-house:

Sl. No.	Description	Capacity & Nos.	Make & year of Mfg.	Calibration Status	Validity period



SUB-SUPPLIER QUESTIONNAIRE
(To be filled in by the Proposed Sub Supplier)

b. List of Testing & Inspection Facilities outsourced, if any with Source of testing and Description enclosed as Annexure: _____

21. **Storage of finished goods (covered / open) :** _____

22. **List of the source / make with location of major raw material, bought out items and out sourced process enclosed as Annexure: _____**

23. **Quality management:**

23.1 **General**

23.1.1. Work Instruction for different processes available. (Y/N). ____

If yes, enclose list as Annexure _____

23.1.2. Evaluation system for raw material/bought out item's supplier is available. (Y/N) _____

23.1.3. Records generated during inspection maintained & available for review (Y/N) _____

23.1.4 Statistical quality control techniques used (Y/N) _____

23.1.5 ISO certificate for the works available (Y/N). ____ If yes, enclose copy as Annexure _____

23.2 **Corrective action**

23.2.1 Specifically confirm whether System for identification & disposition of Non Conformity in the process / product is available. (Y/N) _____

23.2.2 Specifically confirm whether System for Customer complains & their satisfactory disposal is available. (Y/N) _____

23.3. **Documentation Control**

23.3.1 Procedure available for documentation control (Y/N) ____

23.4. **Control of Inspection, Measuring & Testing equipments.**

23.4.1 Procedure for calibration of testing & measuring instrument available. (Y/N) ____

24. **Any Special Information:** _____



SUB-SUPPLIER QUESTIONNAIRE
(To be filled in by the Proposed Sub Supplier)

26. I CERTIFY THAT THE INFORMATION SUPPLIED HEREIN (INCLUDING ALL PAGES ATTACHED) IS CORRECT TO THE BEST OF MY KNOWLEDGE.

SEAL _____
M/S. _____
PLACE _____
DATE _____

SIGNATURE _____
NAME _____
DESIGNATION _____
MOBILE NO _____
EMAIL _____

LIST OF ENCLOSURE:

Certification by Main Supplier: Above information have been verified and found in order / minor changes which have been marked and initialed on this form itself / observed the following discrepancies.

Name : _____ Designation : _____ Signature : _____ Date : _____

NOTE :

- 1. COLUMN SHALL NOT BE LEFT UNFILLED..IN CASE OF NOT APPLICABLE / NOT AVAILABLE, THE SAME SHALL BE INDICATED IN THE PROVIDED SPACE.**
- 2. IN CASE PROVIDED SPACE IS NOT ADEQUATE, INFORMATION SHALL BE PROVIDED AS AN ATTACHMENT.**
- 3. PRODUCT CATALOGUE FOR THE PROPOSED EQUIPMENT/ITEM/PROCESS,IF AVAILABLE, SHALL BE ENCLOSED**

SI No	Surface Location	PGMA	Surface Preparation	Primer		Finish		Total DFT in (µm) min.
				Paint	DFT (µm) min.	Paint	DFT (µm) min.	

IV Gates and damper

01	Gates and Damper more than 95 Deg Centigrade	57 XXX	Power Tool Cleaning to St3 (SSPC-SP3)	Heat Resistant Aluminum Paint Gr 2 to IS 13183 (Two coats)	40	--	-	40
02	Gates and Damper less than 95 Deg Centigrade NOT APPLICABLE	57 XXX	Power Tool Cleaning to St3 (SSPC-SP3)	Red Oxide Zinc Phosphate Primer to IS: 12744(Two Coats)	40	Synthetic Enamel to IS 2932 Grey shade 692 of IS 5 (Two Coats)	40	80
03	Items other than in SL No 03	57 466	DO	DO	40	Synthetic Enamel to IS 2932 Grey shade 692 of IS 5 (Two Coats)	40	80
	Hand rails, Floor Grills	57 466	Hot dip Galvanizing to 610 gm per Sq.M (Minimum) and to a coating thickness of 87 microns (min)					



General Notes:

- ✓ 1) No painting is required for Galvanized items, non-ferrous items.& stainless steel items , except as indicated above.
- ✓ 2) Machined items are to be applied with one coat of temporary rust preventive oil.
- ✗ 3) ~~PGMAs under sub-vendor items viz SCAPH, Pent house ventilation fan & its coupling, seal air fan coupling, support bearing and sub delivery components of ESP, etc are not indicated. However the Painting schedule for all items supplied by all sub-vendors and B01 under the scope of BHEL shall be same as for main equipment covered in this document.~~
- ✓ 4) In components, wherever plates /sheets of thickness less than or equal to 5 mm and rods are used, power tool or hand tool cleaning to SSPC-SP3/SP2 shall be followed.
- ✗ 5) ~~Ground shade/colour of finish paints and identification tag/band for equipments, Fans, piping, pipe services, supporting structures and other components shall be followed as per NTPC doc at site~~
- ✗ 6) ~~All components covered under different PGMAs are to be painted. In case any component is left out, the same shall be deemed to be included under the relevant section~~

Page 1 of 1

VINDHYACHAL , STAGE V, 1X 500 MW, UNIT 13,
Painting Schedule: For APH, ESP, FAN AND GATES AND DAMPER
 PS VINDHYACHAL R549 REV 00 DTD 16 08 2012.
 Issued by Quality Assurance.

TITLE : TECHNICAL SPECIFICATION FOR BOUGHT OUT ITEMS
ITEM : LT MOTOR
Project : BHEL standard

	NAME	DESIGNATION	SIGNATURE	DATE
PREPARED	K S S MANIAN	Sr Addl Engr		29.5.14
CHECKED	S RANGARAJAN	S D G M		29.5.14
APPROVED	S JAYAPRAKASAM	A G M		29.5.14

ISSUED BY EDC ECI

Record of revision

REVISION NO : 01

CI 2.1 Reviewed & Revised

REVISION NO : 00

INITIAL RELEASE : 19.3.2013

Based on TDC TCI 140 Rev 08 & TFN LTM rev 05

CI No.	CHARACTERISTICS	REQUIREMENT	VENDOR COMPLIANCE (Refer Note: 2)
1.0	<u>SITE CONDITIONS</u>		
1.1	Altitude above mean sea level	> 1000 m.	
1.2	Ambient temperature condition	6 to 50°C.	
1.3	Relative humidity	100 %	
1.4	Atmosphere	Tropical ,Dusty, salty, corrosive & highly polluted	
2.0	<u>GENERAL</u>	in a coal based Thermal power plant.	
2.1	Reference standards 	IS 325, IS 1231, IS 4722, IS 6362, IS 2253, IS 12065, IS 12075 , IS 4691 & <u>IS 12615-</u> <u>Energy efficient</u>	
2.2	Design ambient	50 Deg C	
2.3	Application/ Type(Normal/ Energy efficient)	As per Enquiry & PO.	
2.4	Duty cycle	Continuous S1	
2.5	Rated voltage, frequency & Phases	415 V AC ±10%; 50 Hz ± 5%;(PI check enquiry for voltage) 10% absolute sum - 3 phase	
2.6	Minimum starting voltage	80% of the rated voltage	
2.7	Minimum voltage under which motor will run satisfactorily Capacity to restart (at voltage specified in point No. 2.4)	75% of the rated voltage for 5 minutes i. TWO successive starts from cold condition ii. Two HOT restarts starts from Hot condition iii. Three equally spread start per hour	
2.8	High speed bus transfer withstand capability	Suitable to withstand 150 % of rated voltage	
2.9	Type of balancing for rotor	Dynamic balancing	
2.10	Direction of rotation	Suitable for both direction	
2.11	Direction of cooling air	Non-drive end to driving end	
2.12	Class of insulation	Class F with temperature rise limited to Class B.	
2.13	Winding treatment	The insulation shall be given tropical and fungicidal treatment for successful operation of the motor in hot , humid & tropical climate.	
2.14	Allowed winding temperature rise at continuous full load	60°C by thermometer method & 70°C by resistance method	

CI No.	CHARACTERISTICS	REQUIREMENT	VENDOR COMPLIANCE (Refer Note: 2)
2.15	Starting current	Less than or equal to 600% full load current subject to tolerance as per IS.(Normal motor) Less than or equal to 700% full load current subject to tolerance as per IS.(Energy efficient)	
2.16	Starting time & locked rotor withstand time	The locked rotor withstand time (LRWT) at 110% rated voltage (RV) under HOT condition shall be at least 3 sec more than the starting time at 80% of rated voltage for motors with acceleration time upto 20 sec at RV and 5 sec where the accelerating time is more than 20 sec at RV.	
2.17	Vibration	The peak amplitude of vibration shall be as per IS 12075	
2.18	Noise level	Within the limits specified by IS 12065. (<80 db at full load condition) @ 1 metre distance.	
2.19	Type of enclosure	TEFC, IP 55 as per IS 4691.	
2.20	Type of mounting	Horizontal foot mounted.	
2.21	Bearings	Ball or roller type / bearings effectively sealed against ingress of dust. The bearing shall be so constructed that the loss of lubricating grease is kept to minimum. Sealed bearings are also acceptable.	
2.22	Lubricant Type	Grease	
2.23	Bearing life	Bearings shall have a minimum life of 40000 Working hours.	
2.24	Shaft extension	Motors shall be provided with key slotted bare shaft extension with key at the driving end.	
2.25	Terminal box Type	Weather proof IP 55 as per IS 4691, Capable of being turned through 360° in steps of 90°.	
2.26	Cable gland and lugs	Double compression type nickel plated brass cable glands and insulated tinned copper crimping lugs to suit the cable size shall be supplied along with the motor. i) Size of power cables will be intimated after PO. ii) For space heater cable glands and lugs suitable for 2CX2.5 to be provided	
2.27	Type of terminals	Stud / screw type with plain washers, spring washers / checknuts & lugs	

CI No.	CHARACTERISTICS	REQUIREMENT	VENDOR COMPLIANCE (Refer Note: 2)
2.28	Fault level	40 KA for 0.25 Sec (Suitable HRC fuse backup will be provided by BHEL in MCC/switchgear)	
2.29	Painting	Epoxy based paint (Colour shade 631/ Shade 632/ Shade 275/ RAL 5012 as per IS:5. This will be confirmed after PO.	
30.0	Space heaters		
30.0.A	Motors above 30 kW	Separate space heater suitable for 240V, 1 Phase, AC ,50 Hz shall be provided	
30.0.B	Motors below 30 kW	Winding shall be suitable for heating continuously at 24 V, Single phase, AC,50 Hz	
30.0.C	Terminals for space heater	Separately terminated with clear identification in main terminal box.	
31.0	RTD for winding	Two numbers of Thermistors / RTD for each phase as below are to be provided A. Motors above 37 Kw shall have thermistors Or RTD if specifically called for in enquiry. B. Motor rated 160kW and above shall have RTDs	
32.0	Bearing RTD	For motors 132 Kw and above bearing temperature detectors(RTD) shall also be offered.	
33.0	Terminals for RTD/ Thermistor	Thermistors/ RTDs shall be terminated in a auxiliary terminal box. Details shall be furnished in TB diagram.	
34.0	Earthing	Two no of earthing provisions on terminal box and on motor body	
35.0	Name plate	As per IS 325 and Addl data on name plate:: a. Bearing DE/ NDE details. b. Year of manufacture	
36.0	Lifting Device	Eye bolt or lugs to facilitate safe lifting	
37.0	<u>INSPECTION & TESTING</u>	As per applicable quality plan	

CI No.	CHARACTERISTICS	REQUIREMENT	VENDOR COMPLIANCE (Refer Note: 2)
38.0	<p><u>DOCUMENTS</u></p> <p>a) Along with offer:</p> <p>b) After placement of Purchase order (within 15 days)</p>	<p>One set of technical data sheet as per the enclosed format and Motor general arrangement drawing giving foundation details, shaft details.</p> <p>Three sets of the following for approval:</p> <ol style="list-style-type: none"> 1. Technical Data sheet as per the enclosed format of TECI LTMOTOR REV 00- sh 6 to 8 2. Motor general arrangement drawing giving foundation details, shaft details and weight 3. Motor Terminal box arrangement drawing 4. Motor characteristic curves . <p>The following shall be submitted</p> <ol style="list-style-type: none"> 1. Guarantee certificate. 2. O & M manuals. <p><u>3. Acceleration time and LRWT calculation shall be submitted for review.</u></p>	
39.0	<p><u>PACKING</u></p>	<p>As per Packing Procedure QA:CI:STD:PR:03 or as per Manufacturer's Standard Practice subject to approval . The packing shall meet the Transport , Environment & Storage hazards.</p> <p><u>Vendor shall check the applicable rated voltage in enquiry.</u></p>	

NOTE:

1. Refer current valid list for revision status of Quality Plan & Packing Procedure.
2. In 'Vendor compliance' column Vendor to indicate 'YES', 'NO' or 'NOT APPLICABLE'. Clarification , if any, in this column will not be considered.

PO no ::

DATA SHEET - Cust No ::

Project ::

CL. NO	CHARACTERISTICS	Vendor data (To be filled by vendor)
1.0	Application	
1.1	Fan / Load Curve referred	
2.0	Manufacturer	
3.0	Type & frame size	Normal / Energy efficient Frame size:
3.1	Degree of Protection	IP55
4.0	Rated output in kW	
4.1	Rated speed	
5.0	Rated voltage , frequency & phases	<ul style="list-style-type: none"> • 415 V AC ±10%; 50 Hz ± 5%; (Check voltage as per enqy), 10% absolute sum - 3 phase
6.0	Full load current	Amps
7.0	Energy efficient	As per IS 12615
8.0	Efficiency & power factor at Full load	Eff-- PF---
9.0	Efficiency & power factor at 75 % load	Eff-- PF---
10.0	Efficiency & power factor at 50 % load	Eff-- PF---
11.0	Duty Cycle	S1 - Continuous
12.0	Rated torque	
13.0	Starting current	600% of full load current
14.0	No load current (with mechanism coupled)	@ RV and Frequency
15.0	Starting torque in % of full load torque	
16.0	Pull up torque in % of full load torque	
17.0	Pull out torque in % of full load torque	
18.0	No load starting time (without mechanism coupled)	
19.0	Locked rotor withstand time at rated voltage	a. Hot b. Cold
20.0	Locked rotor withstand time at minimum starting voltage	a. Hot b. Cold
21.0	Locked rotor withstand time at 110% rated voltage	a. Hot b. Cold
22.0	Starting time at minimum starting voltage with mechanism coupled	
23.0	Starting time at rated voltage with mechanism coupled	
24.0	Maximum permissible starting time	
25.0	Stator thermal time constant	Minutes
26.0	Type & No of terminals brought out	

CI no	CHARACTERISTICS	Vendor Data (To be filled by vendor)
27.0	Stator winding connection	Delta / star
28.0	Class of insulation & temperature rise	Class F; 60°C by thermometer method / 70°C by resistance method.
29.0	Minimum permissible starting voltage	Volts
30.0	Resistance per phase @20 Deg C (Indicative)	Ohms
31.0	No of successive starts in Hot condition	ONE / TWO
32.0	Quantity and power consumption of space heater	Qty== Watts==
33.0	Direction of rotation	Bi-Directional.
34.0	Bearing make & type	Make:: Drive End; Non Drive End;
35.0	Lubricant quantity , grade & recommended interval of lubrication	
36.0	Type of mounting & shaft orientation <u>Terminal Box</u>	Foot mounting; Horizontal.
37.0	Location & angle of rotation	
38.0	Gland size for stator winding	
39.0	Gland size for space heater	Suitable for 2CX2.5 sq.mm(armoured), if applicable.
40.0	Cable entry	
41.0	GD ² of motor (kg-m ²)	
42.0	Total weight of motor (kg).	
43.0	Weight of stator (kg)	
44.0	Weight of rotor (kg)	
45.0	Anticipated bearing life in Hours	
46.0	Method of connection to driven equipment	
47.0	Limiting rotor temperature for determining safe stall time	<input type="checkbox"/>
48.0	RTD for winding/ Bearing	Applicable YES NO
49.0	Grade of balance of motor	
50.0	Standard continuous rating at 40 Deg C ambient.	
51.0	Derated rating of motor at 50 Deg C.	
52.0	a. Locked Rotor KVA b. Ratio of Locked rotor KVA / Rated KW	
53.0	a. Motor Dynamic Load b. Motor Static load	Upward/ Downward— Upward / Downward—
54.0	PAINT SHADE	

Vendor's signature and seal

Rev No ::

Date ::

The following curves are to be enclosed during datasheet approval.

1. GA drawing , Terminal box arrangement
2. Torque Vs Speed with load curve superimposed.
3. Speed Vs Current
4. Time Vs Current
5. Thermal with stand curve
6. Load Vs Efficiency
7. Load Vs Slip
8. Load Vs Power factor
9. Speed Vs Time
10. Load Vs Current.

The following information shall be specifically provided for motors suitable for VFD drive (if called for in eqny during datasheet approval in addition to datasheet.

1. **Stator RESISTANCE**
2. **Stator leakage reactance**
3. **Magnetising reactance**
4. **Rotor resistance referred to stator**
5. **Rotor reactance referred to stator**

Vendor's signature and seal.

Date ::

Bharat Heavy Electricals Limited

HIGH PRESSURE BOILER PLANT , TIRUCHIRAPPALLI 620 014.

TECHNICAL DELIVERY CONDITIONS





FOR SUB - DELIVERY COMPONENTS OF
CONTROLS AND INSTRUMENTATION/FB

TCI :143, Rev. 08

PAGE 01 OF 08

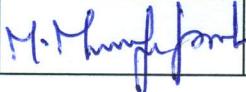
POWER CYLINDERS - REGULATING TYPE

Revision History

REV. NO.	DATE	DESCRIPTION	PREPARED	REVIEWED	APPROVED	
					Engg.	QAC
			M.Muruga Prabu	V.M.Selvaraaj	D.Mahendrababu	N.Sridhar
01 - 07	----	General Revisions	- Sd -	- Sd -	- Sd -	- Sd -
08	25-09-13	Revised after revisit				

SL. NO.	DETAILS	TECHNICAL REQUIREMENTS	
1.0	Site conditions :		
1.1	Ambient temperature	50° C	
1.2	Relative humidity	100 %	
1.3	Atmosphere	Dusty, Salty, Highly Polluted & Corrosive	
1.4	Altitude above MSL	1000 metre	
2.0	General :		
2.1	Application	Regulating Dampers	
2.2	Actuator type	Double acting piston type	
2.3	Air Supply	Power	Minimum : 3 kg/sq cm (g)
		Air	Maximum : 7 kg/sq cm(g)
		Signal Air	Minimum : 0.2 to 1kg/sq cm(g)
2.4	Duty Cycle	Continuous	
2.5	Location	Outdoor	
2.6	Mounting	Foot mounted, with output lever having an angular movement	
2.7	Angle of Travel	Refer Purchase Enquiry	
2.8	Operation Speed required.	Refer Purchase Enquiry	
2.9	Action on Loss of Power Air Supply.	Stay put (Fail freeze)	
2.10	Action on Loss of Command Signal.	Stay put (Fail freeze)	
2.11	Position indicator	1 No. local mechanical position indicator is required	
2.12	Provision for reversal of action	Required	
2.13	Type of stay put device	Self Reset	

SL. NO.	DETAILS	TECHNICAL REQUIREMENTS
3.0	Material :	
3.1	Piston rod	Hard chrome plated high strength steel
3.2	Piston	High Strength Steel
3.3	Cylinder barrel	Honed & hard chrome plated seamless Carbon steel
3.4	Piston& Cylinder seals	Viton
4.0	Accessories	
4.1	Limit Switch :	
4.1.1	Quantity	One for open and one for close
4.1.2	Number of contacts	In case of Conventional positioner 2 NO + 2 NC
		In case of SMART positioner 1 NO + 1 NC
4.1.3	Type	Snap action
4.1.4	Limit Switch Enclosure	Dust & Weather Proof, IP 65
4.1.5	Contact Rating	5A at 240 V AC / 0.2A at 220 V DC
4.1.6	Make	Shall be as per the manufacturer's standard
4.2	Positioner :	
4.2.1	Features	Input Signal Air: 0.2 to 1kg/sq cm (g). Positioner shall be suitable for working at an air pressure of 3 to 7 kg/sq.cm.(g) Shall be integrally mounted on the power cylinder and shall be suitable for both direct and reverse acting. Each Positioner shall be provided with three pressure gauges. One for Signal Air and one each on either side of the power air to the cylinder.
4.2.2	Cam characteristics	1 No. linear cam to be fixed on the positioner. 1 No. equal percentage, 1 No. square root and 1 No. blank cam to be supplied extra along with the Positioner in a separate pack. (Refer to Note-2)

SL. NO.	DETAILS	TECHNICAL REQUIREMENTS
4.2.3	Enclosure	Shall be as per manufacturer's standard
4.2.4	Applicability of SMART Positioner	Refer Purchase enquiry. Separate technical specification for SMART positioner will be attached, if applicable.
4.3	Air Lock Device :	
4.3.1	Type	Set point adjustable with Self Reset
4.4	Air filter cum regulator :	
4.4.1	Supply air pressure	7 Kg / sq.cm
4.4.2	Type	Diaphragm
4.4.3	Pressure rating	15 Kg / sq.cm
4.4.4	Material : (If there any project specific requirement the same will be indicated in the purchase enquiry)	
	a. Body	Die-cast aluminium
	b. Inner valve and seating	Stainless steel
	c. Spring	Stainless steel
4.4.5	Output pressure	0 – 7 Kg / sq.cm
4.4.6	Filter size	Pneumatic positioner - 25 microns.
		SMART positioner – 5 microns
4.4.7	Make	Placka/Shavo Norgren
4.4.8	Pressure gauge :	
	a. Dial	50 mm Diameter
	b. Type	Bourdon

SL. NO.	DETAILS	TECHNICAL REQUIREMENTS
	c. Material	Phosphor bronze (Bourdon)
	d. Range	0 – 10 Kg / sq cm
	e. Accuracy	± 5%
	f. Make	Shall be as per manufacturer's standard
4.4.9	Air connection inlet	Air connection inlet shall be suitable for accepting ¼" OD PVC sheathed copper tubing
4.5	Position Transmitter :	
	a. Type	Electronic, Inductive – Non-Contact type, 2 wire
	b. Output	4-20 mA, linear DC output@ 600 ohms max.
	c. Power supply	24VDC, Loop Powered from the control system
	d. Enclosure	Die-cast aluminium, Dust & Weatherproof IP 65
	e. Accuracy	± 1% of span
	f. Make	Shall be as per manufacturer's standard
4.6	Hand wheel / Lever	To be provided along with power cylinder for manual operation.
4.7	I/P convertor	Refer purchase enquiry for applicability.
4.8	Junction Box	
4.8.1	Junction Box	All the electrical connections from the accessories input and output signals, shall be wired suitably as per the wiring drawing to the junction box. Protection Class: IP-65. Terminal blocks shall be of Cage-Clamp type, suitable for 2.5 sq.mm. Cable.
4.8.2	Termination of external cable. Vendor to follow as per the project	3 nos. of double compression type brass with nickel plated weather proof cable glands suitable for cable OD of 18 mm

SL. NO.	DETAILS	TECHNICAL REQUIREMENTS
	specific BHEL Terminal block wiring drawing.	3 nos. of 9 pin plug & socket connector with socket mounted on terminal box and plug may be supplied as loose to suit cable of OD 18 mm.
5.0	Linkage rods	The Linkage rods shall be supplied as per the drawings referred in the purchase enquiry. The application names & tag nos. have to be painted on the linkage rods for easy identification.
6.0	Characteristics Power cylinder with Positioner	
6.1	Sensitivity	± 0.5 % of input span under no load.
6.2	Repeatability	± 1 % of output span under no load.
6.3	Accuracy	± 3 % of output span under no load
6.4	Hysteresis	± 1 % of output span under no load.
7.0	Standards	
8.0	Inspection & testing	As per quality plan CI:QAC:STD:QP:42 (latest revision) or project specific quality plan. The applicable quality plan will be indicated in the purchase enquiry.
9.0	Painting/Finish for both Power Cylinder & Linkage rods	
	a. Paint Shade	Shall be as per manufacturer's standard
	b. Finish	Corrosion resistant, Epoxy based resin.
10.0	Documents	
10.1	Documents to be submitted in soft copy with complete details, along with the offer & during approval stage.	<ol style="list-style-type: none"> 1. Vendor to submit a duly filled in power cylinder datasheet furnished by BHEL for evaluation. 2. General Arrangement drawing of Power Cylinder assembled with accessories indicating the dimensional details, mounting

SL. NO.	DETAILS	TECHNICAL REQUIREMENTS
		<p>arrangement& foundation details. Vendor has to submit a neat & legible, soft copy of the Auto Cad drawing in pdf version.</p> <p>3. Tubing drawing indicating all the accessories.</p> <p>4. Wiring drawing with terminal blocks numbers.</p> <p>5. Taking care of all the requirements indicated in the technical specification of the power cylinder, technical specification of the SMART Positioner (for applicable projects) & technical specification of the I to P Converter (for applicable projects)& terminal block wiring drawing, vendor has to submit the No-deviation format. In the "No Deviation format", vendor to specify the BHEL's enquiry details, project details &reference details of the documents/drawings referred above and should indicate as "No – Deviation". If vendor takes any deviation, the offer is considered as incomplete and the same is liable for rejection.</p> <p>6. Point wise Confirmation to the applicable quality plan & packing procedure.</p> <p>7. Offer for :</p> <p>a) Commissioning spares</p> <p>b) Maintenance spares for two years operation</p>

SL. NO.	DETAILS	TECHNICAL REQUIREMENTS
10.2	Operation & Maintenance Manuals	<p>1. 1 set of soft copy (loaded on a DVD) & 1 set of Hard Copy of the O&M manual comprising of the following documents shall be submitted to BHEL Trichy.</p> <ul style="list-style-type: none"> • Operation & Maintenance instruction set. • Power Cylinder datasheets. • Dimensional drawing of the assembled power cylinder. • Tubing drawing. • Wiring Drawing. • Erection/Calibration procedure. • Catalogues of the power cylinder & its accessories. <p>2. 1 No. of O&M manual and erection/calibration procedure shall be placed in each power cylinder package for usage during erection & commissioning activity.</p>
10.0	Packing	As per packing procedure No. QA:CI:STD:PR:03 (latest revision).
11.0	<p>Pre Qualification Requirements (For open tender case only)</p>	<p>Vendor should have supplied and commissioned similar products of suitable ratings to thermal power plant applications and the same shall be working satisfactorily for a period of minimum 2 years as on the date of techno-commercial bid opening.</p> <p>The bidder can offer and supply such equipment with collaboration or valid license agreement for design, engineering, manufacture, supply of such equipment in India provided the collaborator meets the above provenness criteria.</p>

NOTE :-

1. Refer current valid list for revision status of Quality Plan, Drawing No. & Packing Procedure.
2. Foundation bolts, Fasteners & Positioner cams shall be identified separately in shipping list/ Delivery challan.

Bharat Heavy Electricals Limited

HIGH PRESSURE BOILER PLANT , TIRUCHIRAPPALLI 620 014.

TECHNICAL DELIVERY CONDITIONS
FOR SUB-DELIVERY COMPONENTS OF
CONTROLS AND INSTRUMENTATION

TDC : TCI : 317 / REV 02

PAGE 01 OF 03

TECHNICAL SPECIFICATION
OF
SMART POSITIONER

Rev. No.	DATE	DESCRIPTION	PREPARED	REVIEWED	APPROVED	
					ENGG	QAC
			M.Muruga Prabu	V.M.Selvaraaj	D.Mahendrababu	N.Sridhar
00	11-12-2009	Initial Release	-sd-	-sd-	-sd-	-sd-
01	----	General Revisions	-sd-	-sd-	-sd-	-sd-
02	26-09-2013	Revised to edit the various clauses as per the site feedback	<i>M. Muruga Prabu</i>	<i>V.M. Selvaraaj</i>	<i>D. Mahendrababu</i>	<i>N. Sridhar</i>

General instructions to the vendor :-

- Vendor to quote the SMART positioner along with the position feedback module and alarm module.

SI. No	Technical Description/Requirement	
1	SITE CONDITIONS :- Altitude above Sea Level Atmosphere Relative humidity Design Ambient temperature	500 Meters Tropical, Dusty, Windy & Heavily polluted atmosphere 0 – 95 % 50 °C
2	Make	SIEMENS / ABB
3	Type of Input	4-20 mA, 24VDC , 2 wire system (Loop powered from the external supply)
4	Operational signal range	3.6 mA - 21 mA (4-20 mA). Split range operation shall also be possible.
5	Voltage	Vendor to specify.
6	Input impedance	Vendor to specify.
7	Supply Air pressure	5 – 7 kg/cm ²
8	Air Capacity	Vendor to match with the requirement of the actuator.
9	Sensitivity, Characteristic Deviation, Hysteresis	Vendor to match with the requirement of the actuator.
10	Type of Acting (Direct/Reverse)	Vendor to match with the requirement of the actuator.
11	Stroke time	Vendor to match with the requirement of the actuator.
12	No. of pneumatic outputs (Single/Double)	Vendor to match with the requirement of the actuator.
13	Pneumatic Process Connection	¼" NPT (F)

SI. No	Technical Description/Requirement	
14	Communication by Hart Protocol	SMART positioner shall be compatible for Remote calibration & Diagnostics using Hart Management System.
15	Calibration	SMART positioner shall be compatible for Auto Start with self calibration, Remote calibration & manual calibration using push buttons available on the positioner.
16	Position feed back	4-20mA position feedback signal shall be provided.
17	Indication for travel	Electronic Indication shall be provided.
18	Electrical Cable entry	Side or bottom entry to avoid water ingress.
19	Protection Class	IP 65 minimum
20	Action of actuator during 4 to 20 mA control signal failure.	SMART positioner shall be compatible for achieving Fail Open, Fail Close & Stay put (Fail freeze) functions.
21	Accessories	For Supply & output pressure, gauges shall be provided.
22	EMC Compliance	SMART positioner shall conform to IEC 61000-6-2, 3, IEC 61326; or equivalent standards.
23	Influence of Temperature rise & Vibration effect on SMART Positioner	Vendor to specify.

NOTE

THE FOLLOWING CABLE GLANDS / PLUG AND SOCKETS SHALL BE PROVIDED.

(a). FOR OPEN/CLOSE DUTY POWER CYLINDER

- (i). 2 Nos., 9 PIN PLUG & SOCKET (SOCKET MOUNTD ON TERMINAL BOX BUT PLUG MAY BE SUPPLIED AS LOOSE) TO SUIT 4PAIR x 0.5SQ.MM, INSTRUMENTATION CABLE OF OD 17MM.
- (ii). 1 No. CABLE GLAND TO SUIT 5C x 2.5 SQ.MM (Cu.) CONTROL CABLE OD 17MM OD

(b). FOR REGULATING DUTY POWER CYLINDERS

- (i). 3 Nos., 9 PIN PLUG & SOCKET (SOCKET MOUNTD ON TERMINAL BOX BUT PLUG MAY BE SUPPLIED AS LOOSE) TO SUIT 4PAIR x 0.5SQ.MM, INSTRUMENTATION CABLE OF OD 17MM

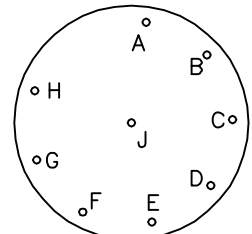

9 PIN PLUG & SOCKET ARRANGEMENT

TB DIAGRAM OF OPEN/CLOSE DUTY POWER CYLINDER

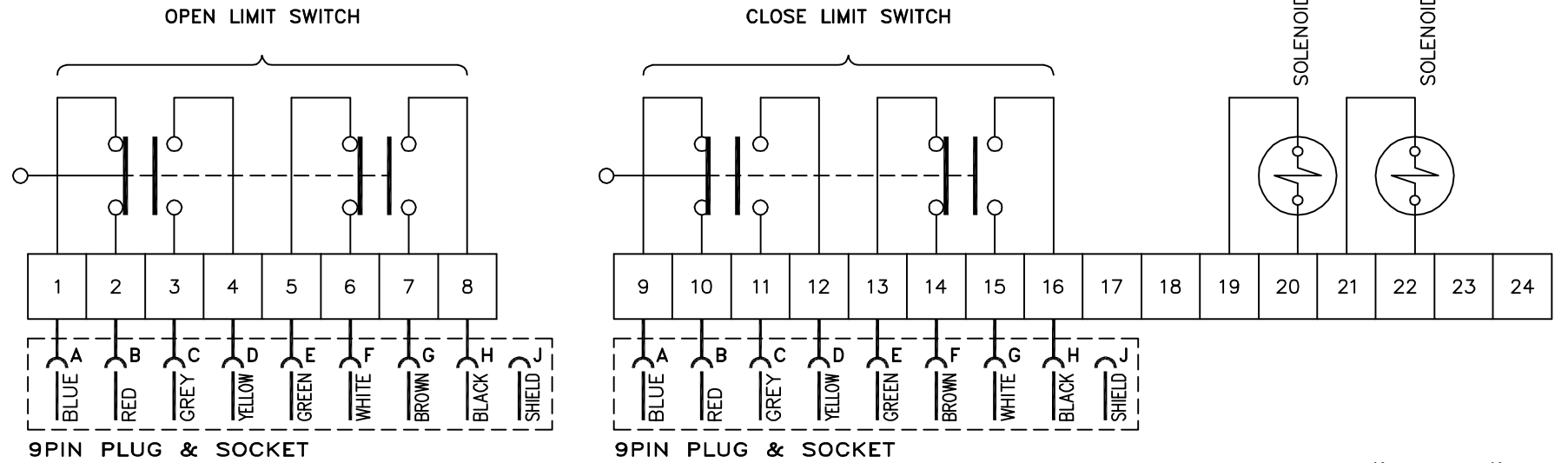

TB DIAGRAM OF REGULATING DUTY POWER CYLINDER

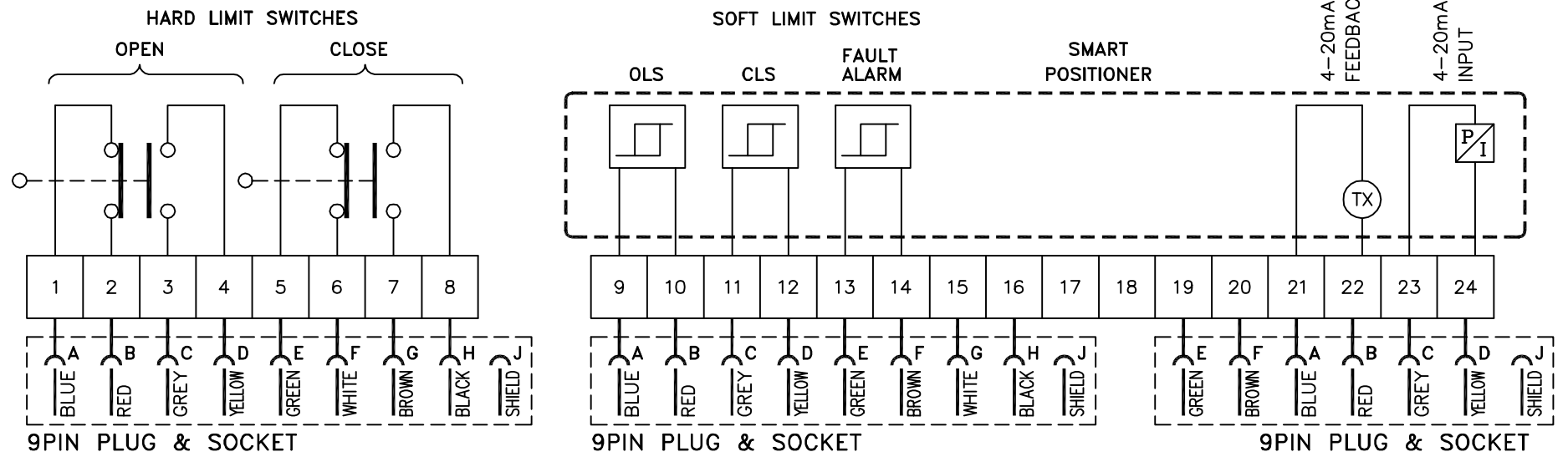

NTPC DRG. No. : 9572-102-PVM-L-XXX
Sheet 01 of 01

REV	DATE	ALTERED :
		CHD. / APPD. :
ZONE		

CAUTION: The information on this document is the property of BHARAT HEAVY ELECTRICALS LTD. It must not be used directly or indirectly in any way detrimental to the interest of the company.



PROJECT :		GADARWARA SUPER THERMAL POWER PROJECT				
		STAGE-1, 2 x 800 MW, Customer No. 1804 & 1805				
		STEAM GENERATOR PACKAGE				
CUSTOMER :		NTPC LIMITED (A GOVERNMENT OF INDIA ENTERPRISE)				
BHARAT HEAVY ELECTRICALS LTD UNIT: HIGH PRESSURE BOILER PLANT TIRUCHIRAPALLI - 620014	DRN	NAME	SIGNATURE	DATE	NO. OF VAR	
	CHD	A.ThambuRaj	<i>[Signature]</i>	27-11-13		—
	APPD	V.M.Selvaraj		27-11-13		
DEPT.-C & I	SCALE	WEIGHT (Kg)	REF TO ASSY / OLD DWG		No OF ITEMS	
CODE - 392	NTS		—			
TITLE		CARD CODE	BHEL DRG. No. :		REV	
TERMINAL BLOCK DIAGRAM FOR POWER CYLINDER (DRAWN FOR INTERMEDIATE POSITION OF PC)		U 01	3-97-599-21822		00	



CONTROLS AND INSTRUMENTATION/QA/FB

STANDARD QUALITY PLAN FOR

PNEUMATIC ACTUATOR (POWER CYLINDER) (OPEN / CLOSE AND REGULATING TYPE)

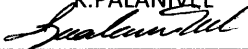
REV	DATE	PREPARED	REVIEWED	APPROVED	REVISION HISTORY
00	14/05/1993	Sd/-	Sd/-	Sd/-	Initial release.
01	16/06/1997	Sd/-	Sd/-	Sd/-	Format Revised.
02	21/06/2002	Sd/-	Sd/-	Sd/-	Department name changed, CTQ requirements added & General revision.
03	08/01/2004	Sd/-	Sd/-	Sd/-	Revised to include the Comments/ Feedback of internal discussion.
04	14/09/2010	RM.VAIRAVAN 	N.SRINIHAR 	K.PALANIVEL 	Format Changed. Revised as per Feedbacks from QC and Engineering during discussion.



BHARAT HEAVY ELECTRICALS LIMITED
TIRUCHIRAPPALLI - 620014

QUALITY PLAN FOR
PNEUMATIC ACTUATOR (POWER CYLINDER)
(OPEN / CLOSE AND REGULATING TYPE)

QA:CI:STD:QP:42
 Rev: 04 Page: 2 of 4

Sl. No	Component & Operation	Characteristics	Class	Type of Check	Quantum of check		Ref Doc. & Acceptance STD	Format of record	AGENCY			Remarks
					M	B/C			M	B	C	
A RAW MATERIALS & BOUGHT OUT ITEMS INSPECTION												
01	Cylinder Piston rod	a. Material	Critical	CHEM	One of sample	-	Specification, BS 970	TC	V	V	-	
		b. Dimension	Critical	MEAS	-do-	-	Mfr. Std.	IIR/LGB	P	-	-	
02	" O " ring	a. Material	Critical	CHEM	-do-	-	Specification	TC	V	V	-	
		b. Dimension	Critical	MEAS	-do-	-	Mfr. Std.	IIR/LGB	P	-	-	
		c. Hardness	Critical	MEAS	-do-	-	-do-	TC	V	V	-	
03	Cylinder Barrel & End Cover	a. Material	Critical	CHEM	-do-	-	Specification	TC	V	V	-	
		b. Dimension	Critical	MEAS	-do-	-	Mfr. Std.	IIR/LGB	P	-	-	
04	Piston Cylinder	a. Pressure Resistance Test	Major	PHYS	-do-	-	JIS B 8377	IIR/LGB	P	V	-	
05	Air filter Regulator	a. Make & Type	Major	PHYS	100%	-	Specification, Data Sheet	IIR/LGB	P	-	-	
		b. Output Gauge range	Major	PHYS	-do-	-	Specification	IIR/LGB	P	-	-	
		c. Process connection Size	Major	MEAS	-do-	-	-do-	IIR/LGB	P	-	-	
		d. Filter size in Microns	Major	PHYS	-do-	-	-do-	TC	V	V	-	
06	Limit Switches	a. Make & Type	Major	PHYS	-do-	-	Specification, Data Sheet	IIR/LGB	P	-	-	
		b. Functional check	Major	ELEC	-do-	-	Mfr. Std.	IIR/LGB	P	-	-	
07	Air Lock Relay	a. Make & Type	Major	PHYS	-do-	-	Specification	IIR/LGB	P	V	-	
		b. Functional check	Major	ELEC	-do-	-	Mfr. Std.	IIR/LGB	P	-	-	
08	Solenoid valve (Applicable Only for open / close)	a. Make & Type	Major	PHYS	-do-	-	Specification, Data Sheet	TC	P	-	-	
		b. Coil Voltage	Major	MEAS	-do-	-	-do-	TC	P	-	-	
		c. Class of Insulation	Major	PHYS	-do-	-	-do-	TC	P	-	-	
		d. Duty	Major	VISU	-do-	-	Mfr. Std.	TC	P	-	-	
		e. Functional check	Major	ELEC & MECH	-do-	-	-do-	IIR/LGB	P	-	-	
09	Positioner (Applicable only for regulating power Cylinder)	a. Make & Type	Major	VISU	-do-	-	Data Sheet	IIR/LGB	P	-	-	Performance to be checked during complete assembly testing

M- MANUFACTURER/ SUB-VENDOR; B - BHEL / TPI ; C - CUSTOMER / TPI
P - PERFORM; W - WITNESS V - VERIFICATION;



BHARAT HEAVY ELECTRICALS LIMITED
TIRUCHIRAPPALLI - 620014

QUALITY PLAN FOR
PNEUMATIC ACTUATOR (POWER CYLINDER)
(OPEN / CLOSE AND REGULATING TYPE)

QA:CI:STD:QP:42
 Rev: 04 Page: 3 of 4

Sl. No	Component & Operation	Characteristics	Class	Type of Check	Quantum of check		Ref Doc. & Acceptance STD	Format of record	AGENCY			Remarks
					M	B/C			M	B	C	
B INPROCESS INSPECTION												
01	Complete Assembly	a. Functional check	Major	PHYS & ELEC	100%	-	Mfr. Std.	IIR/LGB	P	-	-	
		b. Leak test	Major	PHYS	-do-	-	JIS B 8377	IIR/LGB	P	-	-	
C FINISHED PRODUCT INSPECTION												
01	Routine Test	a. No Load test	Major	PHYS	100%	20%	Mfr. Std.	IIR/LGB	P	W	-	
		b. Verification of Mounting of Accessories	Major	VISU	-do-	-do-	BHEL App. Drg.	IIR/LGB	P	W	-	
		c. Dimensional check including Process connections	Major	MEAS	-do-	-do-	BHEL App. Drg.	LGB	P	W	-	
		d. Verification of name plate for Type & Model Number	Major	VISU	-do-	-do-	BHEL App. Drg.	IIR/LGB	P	W	-	
		e. Stroke length & Time	Major	MEAS	-do-	-do-	Spec. & BHEL App. Data Sheet	IIR/LGB	P	W	-	
		f. Verification of accessories (Make and Model number)	Major	VISU	-do-	-do-	Spec. & BHEL App. Data Sheet	IIR/LGB	P	W	-	
		g. Performance test (Sensitivity, Hysterisis, Accuracy, Repeatability) Applicable for Regulating duty	Major	MEAS	-do-	-do-	Specification	IIR/LGB	P	W	-	
		h. Stay put device Operation	Major	PHYS	-do-	-do-	Mfr. Std.	IIR/LGB	P	W	-	
		i. Solenoid valve – Coil voltage rating, Insulation & duty (Applicable only for open/ close duty)	Major	VISU & ELEC	-do-	-do-	BHEL App. Data Sheet	IIR/LGB	P	W	-	
		j. Air Filter- Filter Element size in microns	Major	VISU	-do-	-do-	Specification	IIR/LGB	P	W	-	
02	Type Tests	a. Load operation test	Major	PHYS	One of sample	One of sample	Mfr. Std.	TC	P	V	-	
		b. Durability test	Major	PHYS	-do-	-do-	JIS B 8377	TC	P	V	-	

M- MANUFACTURER/ SUB-VENDOR; B - BHEL / TPI ; C - CUSTOMER / TPI
P - PERFORM; W - WITNESS V - VERIFICATION;



D.NOTES:

1.LEGENDS:

MECH	:	Mechanical	MEAS	:	Measurement
ELEC	:	Electrical	TC	:	Test certificate
TR	:	Test Report	CHEM	:	Chemical
VISU	:	Visual	IIR	:	Internal Inspection Report

2. The vendor shall arrange all testing facilities at their works. Tests for which facilities are not available are to be carried out at recognized National Test Houses like ETDC/CIL/NPL/ERTL etc., at vendor cost.
3. Through Log Book / any other documents available at the vendor's works, it shall be possible to correlate the finished products with raw material and in process stage checks / inspection carried out.
4. All Measuring and Testing Instruments shall be periodically calibrated from recognized test houses & certificates made available during inspection for verification.

5. Test reports for routine tests are to be furnished by the vendor.
6. Type test certificate shall not be earlier than 5 years from the date of Purchase enquiry.
7. Vendor to give tentative inspection program in advance and confirm exact date two weeks in advance for arranging BHEL's inspection.
8. Packing shall be as per the "PACKING PROCEDURE" indicated in the specification.

E. REFERENCE STANDARDS:

(For Indicated Standards Refer the Latest Version)



JIS B 8377	:	Specification for Pneumatic Cylinder
BS 970	:	Specification for Wrought Steel for Mechanical end

SQP42R4.DOC

**BHARAT HEAVY ELECTRICALS LIMITED
TIRUCHIRAPPALLI**

**CONTROLS AND INSTRUMENTATION / FB
QUALITY ASSURANCE**

**STANDARD PACKING PROCEDURE
FOR
ELECTRICAL ACTUATORS, POWER CYLINDERS AND
ELECTRICAL EQUIPMENTS**

Rev	Date	Prepared	Checked	Approved	Revision History
00	01.01.96	Sd/-	Sd/-	Sd/-	Initial History
01	28.03.02	A.J.OMPRAKASH Sd/-	R.VARADARAJAN Sd/-	G.MATHIYALAGAN Sd/-	Department name changed
02	26.02.07	RM.VAIRAVAN 	N. SRIDHAR 	S.SOMASUNDARAM 	Revised after discussion with Shipping Dept.

1.0 SCOPE

- 1.1 This procedure gives minimum guidelines to be complied with for packing of Electrical actuators, Power cylinders and other Electrical equipments. This packing shall be suitable for different handling operations and for the adverse conditions during transportation and during indoor / outdoor storage for periods more than one year.

2.0 WOOD SPECIFICATION FOR PACKING

- 2.1 Rubber wood as per manufacturer standard.
2.2 Silver Oak as per procedure PR:CHEM:017 or as per relevant International Standards.

3.0 PACKING

- 3.1 For Inland packing, rubber wood and export packing Silver Oak wood shall be used. The wood used shall be seasoned and treated.
- 3.2 The required wood case for the equipment to be packed shall be made out of individual planks of single length. The case should not have joints. Sufficient number of horizontal, vertical and diagonal planks (dimensions depending up on case size) shall be used for binding and strengthening runners have to be provided with metallic sling plates for handling.
- 3.3 Support planks are to be provided such that, no force is acting on the parts of equipment or its parts.
- 3.4 Power cylinders have to be packed with the piston in the closed condition.
- 3.5 Preservative chemicals are to be applied, wherever required.
- 3.6 Blank holes if any, shall be plugged.
- 3.7 Spring actuated equipments have to be de-energised before packing.
- 3.8 The equipments covered with a polythene sheet shall be kept inside the box, followed by coir, wooden bottoms, thermo coal, etc to prevent vibration effect during loading, transportation, etc.
- 3.9 The gap between job and the box shall be filled with suitable material like jute, coir, thermo coal, etc.
- 3.10 On all sides of the inner case, black polythene sheet shall be nailed.
- 3.11 Loose items of the equipment, if any, shall be packed separately.
- 3.12 Each case must have sufficient quantity of silica gel, packed in cotton cloth bags, shall be kept at different places as required.

The bags used shall have the following information marked on it.

Silica Gel activator type:

Blue: Active

Rose: Reduced active

White: No activity. To be replaced with fresh Silica gel.

4.0 MARKING

- 4.1 After completing the packing, Stencil marking, as per dispatch instructions and symbol marking as per Annexure – I shall be made. Please ensure the box is stenciled with “FRAGILE ITEM”, “HANDLE WITH CARE”

5.0 PACKING SLIP

- 5.1 A copy of the packing slip, kept in a polythene cover shall be kept inside the box. Another copy of the packing slip, kept in a polythene cover shall be kept out side the box and covered with a metallic plate to the case.

6.0 CAUTION

Do not pack any other Mechanical items with this case.

7.0 GENERAL

- 7.1 These packing procedures are the minimum requirements in addition to the standard instructions mentioned in the Purchase Order and Specification.
- 7.2 Deviation to meet the packing procedure requirements / non-clarity in packing approach in any quotation will be liable for rejection of offer.

ANNEXURE - 1

TO

PROCEDURE NO:CI:QAC:PR:02/00 ; PR:03/00 ; PR:04/00

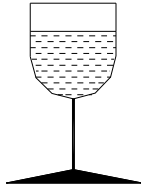

FRAGILE, HANDLE WITH CARE

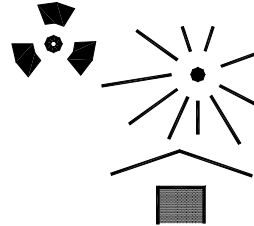

PROTECT FROM HEAT AND RADIOACTIVE SOURCES



USE NO HOOKS

NOTE: The design of heavy goods packages cannot always resist top lifting by grabhooks.



KEEP DRY

NOTE: Not all cases have waterproof internal liners: plywood used in the construction may not have a waterproof glueline.

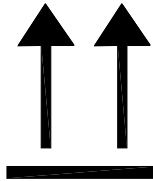

THIS WAY UP

NOTE: Certain designs of small cases make it difficult to distinguish top from bottom.

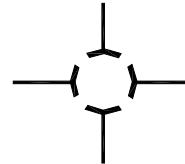

CENTRE OF GRAVITY

NOTE: This should be stencilled as a minimum on the two longest case sides (this information will normally be supplied by the manufacturer of the item(s) packed).

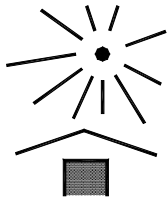

KEEP AWAY FROM HEAT

... kg max

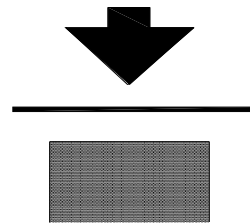

STACKING LIMITATION

NOTE: The maximum load in kilograms should be marked above the arrow.

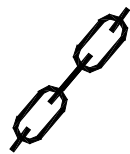

INTERNATIONAL "SLING HERE" SYMBOL

TECHNICAL SPECIFICATION DETAILS FOR INSTRUMENTATION FOR GATES & DAMPERS APPLICATION
IN FLUE GAS DESULFURIZATION (FGD) for VINDYACHAL STAGE-V

SL.NO	INSTRUMENTATION
01.	SPECIFICATION OF TRANSMITTERS FOR PRESSURE, D.P, FLOW & LEVEL
02.	SPECIFICATIONS OF PR. GAUGE, D.P. GAUGE, TEMP. GAUGE AND LEVEL GAUGE.
03.	SPECIFICATION OF PROCESS ACTUATED SWITCHES
04.	SPECIFICATION OF SOLENOID VALVES
05.	SPECIFICATION OF RESISTANCE TEMPERATURE DETECTOR (RTD)
06.	SPECIFICATION OF TEMPERATURE TRANSMITTER
07.	SPECIFICATION OF FLOW ELEMENTS
08.	SPECIFICATION OF FLOW NOZZLE

M. Nayaf
Prepared,

Approved,

CLAUSE NO.	TECHNICAL REQUIREMENTS		
1.00.00	All instruments shall be provided with durable epoxy coating for housings and all exposed surfaces of the instruments.		
2.00.00	SPECIFICATION FOR ELECTRONIC TRANSMITTER FOR PRESSURE, D.P., FLOW AND LEVEL		
	Sl. No.	Features	Essential/Minimum Requirements
1.	Type of Transmitter		Microprocessor based 2 wire type, HART protocol compatible.
2.	Accuracy		± 0.1% of calibrated span (minimum)
3.	Output signal range		4-20 mA DC (Analog) alongwith superimposed digital signal (based on HART protocol)
4.	Turn down ratio		10:1 for vacuum/very low pressure applications. 30:1 for other applications.
5.	Stability		± 0.1% of calibrated span for six months for Ranges up to and including 70 Kg/cm ² . ± 0.25% of calibrated span for six months for Ranges more than 70 Kg/cm ² (g).
6.	Zero and span drift		+/- 0.015% per deg.C at max span. +/-0.11% per deg.C at min. span.
7.	Load impedance		500 ohm (min.)
8.	Housing		Weather proof as per IP-55 with durable corrosion resistant coating.
9.	Over Pr.		150% of max. Operating pr.
10.	Connection (Electrical)		Plug and socket type
11.	Process connection		1/2 inch NPT (F)
VINDHYACHAL SUPER THERMAL POWER PROJECT STAGE-V (1X500 MW) FLUE GAS DESULPHURISATION (FGD) SYSTEM PACKAGE	TECHNICAL SPECIFICATION SECTION-VI BID DOCUMENT NO.: CS-2260-109-2	PART-B SUB-SECTION-III-C2 MEASURING INSTRUMENTS	Page 1 of 12

CLAUSE NO.	TECHNICAL REQUIREMENTS																													
	<table border="1"> <thead> <tr> <th data-bbox="380 176 516 260">Sl. No.</th> <th data-bbox="521 176 727 260">Features</th> <th data-bbox="732 176 1411 260">Essential/Minimum Requirements</th> </tr> </thead> <tr> <td data-bbox="380 266 516 394">12.</td> <td data-bbox="521 266 727 394">Span and Zero</td> <td data-bbox="732 266 1411 394">Continuous, tamper proof, Remote as well as adjustability manual from instrument with zero suppression and elevation facility.</td> </tr> <tr> <td data-bbox="380 401 516 772" rowspan="3">13.</td> <td data-bbox="521 401 727 772" rowspan="3">Accessories</td> <td data-bbox="732 401 1411 499">-Diaphragm seal, pulsation dampeners, syphon etc. as required by service and operating condition.</td> </tr> <tr> <td data-bbox="732 506 1411 667">-2 valve manifold for absolute pressure transmitters (3-valve manifold for gauge/ vacuum pressure transmitters) and 5 valve manifold for DP/level/flow transmitters.</td> </tr> <tr> <td data-bbox="732 674 1411 772">-For hazardous area, explosions proof enclosure as described in NEC article 500.</td> </tr> <tr> <td data-bbox="380 779 516 835">14.</td> <td data-bbox="521 779 727 835">Diagnostics</td> <td data-bbox="732 779 1411 835">Self Indicating feature</td> </tr> <tr> <td data-bbox="380 842 516 898">15.</td> <td data-bbox="521 842 727 898">Power supply</td> <td data-bbox="732 842 1411 898">24V DC \pm 10%.</td> </tr> <tr> <td data-bbox="380 905 516 1073">16.</td> <td data-bbox="521 905 727 1073">Adjustment/calibration/maintenance</td> <td data-bbox="732 905 1411 1073">Centralised PC based system (In Employer's Scope). In addition total two (2) no. of hand- held type universal calibrators compatible with HART protocol, shall be provided.</td> </tr> <tr> <td data-bbox="380 1079 516 1207">Notes.</td> <td colspan="2" data-bbox="521 1079 1411 1207">In case it becomes necessary to use a DP transmitter for pressure measurement then a 3-valve manifold should be used in place of 2-valve manifold.</td> </tr> <tr> <td colspan="3" data-bbox="380 1213 1411 1270">LVDT type is not acceptable.</td> </tr> <tr> <td colspan="3" data-bbox="380 1276 1411 1451">Where the process fluids are corrosive, viscous, solid bearing or slurry type, diaphragm seals shall be provided. Parts below the diaphragm shall be removable for cleaning. The entire volume above the diaphragm shall be completely filled with an inert liquid suitable for the application.</td> </tr> </table>	Sl. No.	Features	Essential/Minimum Requirements	12.	Span and Zero	Continuous, tamper proof, Remote as well as adjustability manual from instrument with zero suppression and elevation facility.	13.	Accessories	-Diaphragm seal, pulsation dampeners, syphon etc. as required by service and operating condition.	-2 valve manifold for absolute pressure transmitters (3-valve manifold for gauge/ vacuum pressure transmitters) and 5 valve manifold for DP/level/flow transmitters.	-For hazardous area, explosions proof enclosure as described in NEC article 500.	14.	Diagnostics	Self Indicating feature	15.	Power supply	24V DC \pm 10%.	16.	Adjustment/calibration/maintenance	Centralised PC based system (In Employer's Scope). In addition total two (2) no. of hand- held type universal calibrators compatible with HART protocol, shall be provided.	Notes.	In case it becomes necessary to use a DP transmitter for pressure measurement then a 3-valve manifold should be used in place of 2-valve manifold.		LVDT type is not acceptable.			Where the process fluids are corrosive, viscous, solid bearing or slurry type, diaphragm seals shall be provided. Parts below the diaphragm shall be removable for cleaning. The entire volume above the diaphragm shall be completely filled with an inert liquid suitable for the application.		
Sl. No.	Features	Essential/Minimum Requirements																												
12.	Span and Zero	Continuous, tamper proof, Remote as well as adjustability manual from instrument with zero suppression and elevation facility.																												
13.	Accessories	-Diaphragm seal, pulsation dampeners, syphon etc. as required by service and operating condition.																												
		-2 valve manifold for absolute pressure transmitters (3-valve manifold for gauge/ vacuum pressure transmitters) and 5 valve manifold for DP/level/flow transmitters.																												
		-For hazardous area, explosions proof enclosure as described in NEC article 500.																												
14.	Diagnostics	Self Indicating feature																												
15.	Power supply	24V DC \pm 10%.																												
16.	Adjustment/calibration/maintenance	Centralised PC based system (In Employer's Scope). In addition total two (2) no. of hand- held type universal calibrators compatible with HART protocol, shall be provided.																												
Notes.	In case it becomes necessary to use a DP transmitter for pressure measurement then a 3-valve manifold should be used in place of 2-valve manifold.																													
LVDT type is not acceptable.																														
Where the process fluids are corrosive, viscous, solid bearing or slurry type, diaphragm seals shall be provided. Parts below the diaphragm shall be removable for cleaning. The entire volume above the diaphragm shall be completely filled with an inert liquid suitable for the application.																														

~~3.00.00~~	**ULTRASONIC TYPE LEVEL TRANSMITTERS** NOT APPLICABLE		
	ULTRASONIC TYPE LEVEL TRANSMITTER NOT APPLICABLE		
VINDHYACHAL SUPER THERMAL POWER PROJECT STAGE-V (1X500 MW) FLUE GAS DESULPHURISATION (FGD) SYSTEM PACKAGE	TECHNICAL SPECIFICATION SECTION-VI BID DOCUMENT NO.: CS-2260-109-2	PART-B SUB-SECTION-III-C2 MEASURING INSTRUMENTS	Page 2 of 12

CLAUSE NO.	TECHNICAL REQUIREMENTS																		
4.00.00	ULTRASONIC TYPE LEVEL TRANSMITTER NOT APPLICABLE																		
	SPECIFICATION FOR PR. GAUGE, D.P. GAUGE, TEMP. GAUGE AND LEVEL GAUGE.																		
	<table border="1"> <thead> <tr> <th data-bbox="381 1207 454 1312">SI. No</th> <th data-bbox="454 1207 641 1312">FEATURES</th> <th colspan="3" data-bbox="641 1207 1422 1312">ESSENTIAL/MINIMUM REQUIREMENTS</th> </tr> </thead> <tbody> <tr> <td data-bbox="381 1312 454 1491"></td> <td data-bbox="454 1312 641 1491"></td> <td data-bbox="641 1312 852 1491">Pr. Gauge/ DP Gauge/ Draught gauges</td> <td data-bbox="852 1312 1120 1491">Temperature Gauge</td> <td data-bbox="1120 1312 1422 1491">Level Gauge</td> </tr> <tr> <td data-bbox="381 1491 454 1743">1</td> <td data-bbox="454 1491 641 1743">Sensing Element and material</td> <td data-bbox="641 1491 852 1743">Bourdon for high pressure, Diaphragm/Bellows for low pr. Of 316 SS</td> <td data-bbox="852 1491 1120 1743">Mercury in steel for below 450°C and inert gas actuated for above 450°C of SS bulb and capillary.</td> <td data-bbox="1120 1491 1422 1743">Tempered toughened Borosilicate gauge glass steel armoured reflex or transparent type.</td> </tr> </tbody> </table>	SI. No	FEATURES	ESSENTIAL/MINIMUM REQUIREMENTS					Pr. Gauge/ DP Gauge/ Draught gauges	Temperature Gauge	Level Gauge	1	Sensing Element and material	Bourdon for high pressure, Diaphragm/Bellows for low pr. Of 316 SS	Mercury in steel for below 450°C and inert gas actuated for above 450°C of SS bulb and capillary.	Tempered toughened Borosilicate gauge glass steel armoured reflex or transparent type.			
SI. No	FEATURES	ESSENTIAL/MINIMUM REQUIREMENTS																	
		Pr. Gauge/ DP Gauge/ Draught gauges	Temperature Gauge	Level Gauge															
1	Sensing Element and material	Bourdon for high pressure, Diaphragm/Bellows for low pr. Of 316 SS	Mercury in steel for below 450°C and inert gas actuated for above 450°C of SS bulb and capillary.	Tempered toughened Borosilicate gauge glass steel armoured reflex or transparent type.															
VINDHYACHAL SUPER THERMAL POWER PROJECT STAGE-V (1X500 MW) FLUE GAS DESULPHURISATION (FGD) SYSTEM PACKAGE	TECHNICAL SPECIFICATION SECTION-VI BID DOCUMENT NO.: CS-2260-109-2	PART-B SUB-SECTION-III-C2 MEASURING INSTRUMENTS	Page 3 of 12																

CLAUSE NO.	TECHNICAL REQUIREMENTS				
	SI. No	FEATURES	ESSENTIAL/MINIMUM REQUIREMENTS		
			Pr. Gauge/ DP Gauge/ Draught gauges	Temperature Gauge	Level Gauge
	2	Body material	Die-cast aluminium	Die-cast aluminium	Forged carbon steel/304 SS
	3	Dial size	150mm	150 mm	Tubular covering entire range
	4	End connection	1/2 inch NPT (F)	3/4" NPT (F)	Process connection as per ASME PTC and drain/vent 15 NB
	5	Accuracy	±1% of span	± 1% of span	± 2%
	6	Scale	Linear, 270° arc graduated in metric units	Linear, 270° arc graduated in °C	Linear vertical
	7	Range selection	Cover 125% of max. of scale	Cover 125% of max. of scale	Cover 125% of max. of scale
	8	Over range test	Test pr. for the assembly shall be 1.5 to the max. Design pr. at 38°C.		
	9	Housing	Weather and dust proof as per IP-55	Weather and dust proof as per IP-55	CS/304 SS leakproof
	10	Zero/span adjustment	Provided	Provided	--
	11	Identification	Engraved with service legend or laminated phenolic name plate		
	12	Accessories	Blow out disc, siphon, snubber, pulsation dampener, chemical seal	SS Thermowell	Gasket for all KEL-F shield for transparent type vent and drain valves of Steel/SS as per CS/Alloy process

CLAUSE NO.	TECHNICAL REQUIREMENTS				
5.00.00	SI. No	FEATURES	ESSENTIAL/MINIMUM REQUIREMENTS		
		Pr. Gauge/ DP Gauge/ Draught gauges	Temperature Gauge	Level Gauge	
		(if required by process) gauge isolation valve		Requirement.	
	13	Material of Bourdon/ movement	316 SS / 304 SS	316 SS / 304 SS	
	Notes:-				
	Length of gauge glass shall not be more than 1400 mm. If the vessel is higher, multiple gauge glasses with 50 mm overlapping shall be provided.				
	Where the process fluids are corrosive, viscous, solid bearing or slurry type, diaphragm seals shall be provided. Parts below the diaphragm shall be removable for cleaning. The entire volume above the diaphragm shall be completely filled with an inert liquid suitable for the application.				
	PROCESS ACTUATED SWITCHES				
	FEATURES	ESSENTIAL / MINIMUM REQUIREMENTS			
		Pressure/ Draft Switches/ DP Switches	Temperature switches	Level switches	
Sensing Element	Piston actuated for high pressure and diaphragm or bellows for low pr./ vacuum	Vapor pressure sensing, liquid filled bellow type with SS bulb and capillary (10 m minimum) above gland	Float type switches/RF type for applications as decided by Employer during detailed engineering. Radio-frequency/capacitance type for other application.		
VINDHYACHAL SUPER THERMAL POWER PROJECT STAGE-V (1X500 MW) FLUE GAS DESULPHURISATION (FGD) SYSTEM PACKAGE	TECHNICAL SPECIFICATION SECTION-VI BID DOCUMENT NO.: CS-2260-109-2	PART-B SUB-SECTION-III-C2 MEASURING INSTRUMENTS	Page 5 of 12		

CLAUSE NO.	TECHNICAL REQUIREMENTS																																																			
	<table border="1"> <thead> <tr> <th data-bbox="391 197 570 268">FEATURES</th> <th colspan="3" data-bbox="570 197 1416 268">ESSENTIAL / MINIMUM REQUIREMENTS</th> </tr> </thead> <tbody> <tr> <td data-bbox="391 268 570 411"></td> <td data-bbox="570 268 810 411">Pressure/ Draft Switches/ Switches</td> <td data-bbox="810 268 1066 411">Temperature switches</td> <td data-bbox="1066 268 1416 411">Level switches</td> </tr> <tr> <td data-bbox="391 411 570 520">Material</td> <td data-bbox="570 411 810 520">316 SS</td> <td data-bbox="810 411 1066 520">Bulb 316 SS/ capillary 304 SS</td> <td data-bbox="1066 411 1416 520">316 SS</td> </tr> <tr> <td data-bbox="391 520 570 621">End connection</td> <td data-bbox="570 520 810 621">½ inch NPT (F)</td> <td data-bbox="810 520 1066 621">½ inch NPT (F)</td> <td data-bbox="1066 520 1416 621">Manufacturer standard</td> </tr> <tr> <td data-bbox="391 621 570 764">Over range proof pressure</td> <td data-bbox="570 621 810 764">150% of max. design pr.</td> <td data-bbox="810 621 1066 764">-</td> <td data-bbox="1066 621 1416 764">150% of max. design pressure</td> </tr> <tr> <td data-bbox="391 764 570 869">Repeat-ability</td> <td colspan="3" data-bbox="570 764 1416 869">± 0.5% of full range</td> </tr> <tr> <td data-bbox="391 869 570 974">No. of contacts</td> <td colspan="3" data-bbox="570 869 1416 974">2 No.+2NC. SPDT snap action dry contact</td> </tr> <tr> <td data-bbox="391 974 570 1079">Rating of contacts</td> <td colspan="3" data-bbox="570 974 1416 1079">60 V DC, 6 VA (or more if required by or PLC)*</td> </tr> <tr> <td data-bbox="391 1079 570 1184">Elect. Connection</td> <td colspan="3" data-bbox="570 1079 1416 1184">Plug in socket</td> </tr> <tr> <td data-bbox="391 1184 570 1327">Set point/ dead band adjustment</td> <td colspan="3" data-bbox="570 1184 1416 1327">Provided over full range</td> </tr> <tr> <td data-bbox="391 1327 570 1398">Enclosure</td> <td colspan="3" data-bbox="570 1327 1416 1398">Weather and dust proof as per IP-55</td> </tr> <tr> <td data-bbox="391 1398 570 1680">Accessories</td> <td data-bbox="570 1398 810 1680">Syphon, snubber, chemical seal, pulsation dampeners as required by process</td> <td data-bbox="810 1398 1127 1680">Thermo well of 316 SS and packing glands</td> <td data-bbox="1127 1398 1416 1680">All mounting accessories</td> </tr> </tbody> </table>				FEATURES	ESSENTIAL / MINIMUM REQUIREMENTS				Pressure/ Draft Switches/ Switches	Temperature switches	Level switches	Material	316 SS	Bulb 316 SS/ capillary 304 SS	316 SS	End connection	½ inch NPT (F)	½ inch NPT (F)	Manufacturer standard	Over range proof pressure	150% of max. design pr.	-	150% of max. design pressure	Repeat-ability	± 0.5% of full range			No. of contacts	2 No.+2NC. SPDT snap action dry contact			Rating of contacts	60 V DC, 6 VA (or more if required by or PLC)*			Elect. Connection	Plug in socket			Set point/ dead band adjustment	Provided over full range			Enclosure	Weather and dust proof as per IP-55			Accessories	Syphon, snubber, chemical seal, pulsation dampeners as required by process	Thermo well of 316 SS and packing glands	All mounting accessories
FEATURES	ESSENTIAL / MINIMUM REQUIREMENTS																																																			
	Pressure/ Draft Switches/ Switches	Temperature switches	Level switches																																																	
Material	316 SS	Bulb 316 SS/ capillary 304 SS	316 SS																																																	
End connection	½ inch NPT (F)	½ inch NPT (F)	Manufacturer standard																																																	
Over range proof pressure	150% of max. design pr.	-	150% of max. design pressure																																																	
Repeat-ability	± 0.5% of full range																																																			
No. of contacts	2 No.+2NC. SPDT snap action dry contact																																																			
Rating of contacts	60 V DC, 6 VA (or more if required by or PLC)*																																																			
Elect. Connection	Plug in socket																																																			
Set point/ dead band adjustment	Provided over full range																																																			
Enclosure	Weather and dust proof as per IP-55																																																			
Accessories	Syphon, snubber, chemical seal, pulsation dampeners as required by process	Thermo well of 316 SS and packing glands	All mounting accessories																																																	
VINDHYACHAL SUPER THERMAL POWER PROJECT STAGE-V (1X500 MW) FLUE GAS DESULPHURISATION (FGD) SYSTEM PACKAGE	TECHNICAL SPECIFICATION SECTION-VI BID DOCUMENT NO.: CS-2260-109-2	PART-B SUB-SECTION-III-C2 MEASURING INSTRUMENTS	Page 6 of 12																																																	

CLAUSE NO.	TECHNICAL REQUIREMENTS			
<p>5.01.00</p> <p>6.00.00</p> <p>7.00.00</p> <p>7.01.00</p>	FEATURES	ESSENTIAL / MINIMUM REQUIREMENTS		
		Pressure/ Draft Switches/ Switches DP	Temperature switches	Level switches
	Mounting	Suitable for enclosure/ rack mounting or direct mounting	Suitable for rack mounting or mounting	-
	<p>Where the process fluids are corrosive, viscous, solid bearing or slurry type, diaphragm seals shall be provided. Parts below the diaphragm shall be removable for cleaning. The entire volume above the diaphragm shall be completely filled with an inert liquid suitable for the application.</p>			
<p>Limit switches shall be silver plated with high conductivity and non-corrosive type. Contact rating shall be sufficient to meet the requirement of Fire alarm Control System subject to a minimum of 60V, 6VA rating. Protection class shall be IP-55.</p>				
<p>SOLENOID VALVES</p> <p>Solenoid valves shall fulfill the following requirements : -</p> <p>a) Type 2/3/4 way SS 316/ forged brass (depending on the application subject to Employer's approval during detailed engg.)</p> <p>b) Power supply 24V DC.</p> <p>c) Plug in connector connection.</p> <p>d) Insulation : Class "H"</p>				
<p>TEMPERATURE ELEMENTS NOT APPLICABLE</p>				
<p>THERMOCOUPLE NOT APPLICABLE</p>				
<p>VINDHYACHAL SUPER THERMAL POWER PROJECT STAGE-V (1X500 MW) FLUE GAS DESULPHURISATION (FGD) SYSTEM PACKAGE</p>	<p>TECHNICAL SPECIFICATION SECTION-VI BID DOCUMENT NO.: CS-2260-109-2</p>	<p>PART-B SUB-SECTION-III-C2 MEASURING INSTRUMENTS</p>	<p>Page 7 of 12</p>	

CLAUSE NO.	TECHNICAL REQUIREMENTS																													
7.02.00	<p>THERMOCOUPLE NOT APPLICABLE</p> <p>Resistance Temperature Detector (RTD)</p> <hr/> <table border="0"> <thead> <tr> <th data-bbox="386 1003 483 1035">Sr. No.</th> <th colspan="2" data-bbox="792 1003 1369 1035">Features Essential/Minimum Requirements</th> </tr> </thead> <tbody> <tr> <td data-bbox="386 1073 402 1104">1</td> <td data-bbox="461 1073 630 1104">Type of RTD.</td> <td data-bbox="792 1073 1422 1140">: Four wire, Pt-100 (100 Ohms resistance at zero degree Centigrade).</td> </tr> <tr> <td data-bbox="386 1178 402 1209">2</td> <td data-bbox="461 1178 646 1209">No. of element</td> <td data-bbox="792 1178 927 1209">: Duplex</td> </tr> <tr> <td data-bbox="386 1247 402 1278">3</td> <td data-bbox="461 1247 643 1278">Housing/Head</td> <td data-bbox="792 1247 1422 1339">: IP-55/Diecast Aluminium. Plug in connectors are to be provided for external signal cable connection.</td> </tr> <tr> <td data-bbox="386 1377 402 1409">4</td> <td data-bbox="461 1377 683 1409">Sheathing of RTD</td> <td data-bbox="792 1377 1235 1409">: Metal sheathed, ceramic packed</td> </tr> <tr> <td data-bbox="386 1446 402 1478">5</td> <td data-bbox="461 1446 769 1478">Calibration and accuracy</td> <td data-bbox="792 1446 1268 1478">: As per DIN-43760 Class-A for RTD</td> </tr> <tr> <td data-bbox="386 1516 402 1547">6</td> <td data-bbox="461 1516 634 1547">Characteristic</td> <td data-bbox="792 1516 1422 1583">: Linear with respect to temp, within $\pm 1/2$ percent of top range value.</td> </tr> <tr> <td data-bbox="386 1621 402 1652">7</td> <td data-bbox="461 1621 613 1652">Accessories</td> <td data-bbox="792 1621 1422 1688">: Thermo well (as specified below) and shall be spring loaded for positive contacts with the well.</td> </tr> <tr> <td data-bbox="386 1726 402 1757">8</td> <td data-bbox="461 1726 578 1757">Standard</td> <td data-bbox="792 1726 1422 1793">: DIN-43760 for RTD and ASME PTC-19.3 for Thermo-well.</td> </tr> </tbody> </table>			Sr. No.	Features Essential/Minimum Requirements		1	Type of RTD.	: Four wire, Pt-100 (100 Ohms resistance at zero degree Centigrade).	2	No. of element	: Duplex	3	Housing/Head	: IP-55/Diecast Aluminium. Plug in connectors are to be provided for external signal cable connection.	4	Sheathing of RTD	: Metal sheathed, ceramic packed	5	Calibration and accuracy	: As per DIN-43760 Class-A for RTD	6	Characteristic	: Linear with respect to temp, within $\pm 1/2$ percent of top range value.	7	Accessories	: Thermo well (as specified below) and shall be spring loaded for positive contacts with the well.	8	Standard	: DIN-43760 for RTD and ASME PTC-19.3 for Thermo-well.
Sr. No.	Features Essential/Minimum Requirements																													
1	Type of RTD.	: Four wire, Pt-100 (100 Ohms resistance at zero degree Centigrade).																												
2	No. of element	: Duplex																												
3	Housing/Head	: IP-55/Diecast Aluminium. Plug in connectors are to be provided for external signal cable connection.																												
4	Sheathing of RTD	: Metal sheathed, ceramic packed																												
5	Calibration and accuracy	: As per DIN-43760 Class-A for RTD																												
6	Characteristic	: Linear with respect to temp, within $\pm 1/2$ percent of top range value.																												
7	Accessories	: Thermo well (as specified below) and shall be spring loaded for positive contacts with the well.																												
8	Standard	: DIN-43760 for RTD and ASME PTC-19.3 for Thermo-well.																												
<p>VINDHYACHAL SUPER THERMAL POWER PROJECT STAGE-V (1X500 MW) FLUE GAS DESULPHURISATION (FGD) SYSTEM PACKAGE</p>	<p>TECHNICAL SPECIFICATION SECTION-VI BID DOCUMENT NO.: CS-2260-109-2</p>	<p>PART-B SUB-SECTION-III-C2 MEASURING INSTRUMENTS</p>	<p>Page 8 of 12</p>																											

CLAUSE NO.	TECHNICAL REQUIREMENTS		
7.03.00	<p>Thermo well (for all process temp. elements)</p> <p>(a) Shall be one piece solid bored type of 315 SS of step-less tapered design. (As per ASME PTC 19.3 1974)</p> <p>(b) For Mill classifier outlet long life solid sintered tungsten carbide material of high abrasion resistance shall be provided.</p> <p>(c) For Air & Flue gas 316 SS protecting tube with welded cap. (However contractor shall provide better material for Flue gas service if require based on the specify boiler design parameters).</p> <p>(d) For furnace zone, impervious ceramic protecting tube of suitable material along with Incoloy supporting tubes and adjustable flanges.</p>		
8.00.00	<p>TEMPERATURE TRANSMITTER</p> <p>Following types of 2-wire temperature transmitter (directly powered from 4-20mA input cards of PLC) shall be provided. The temperature transmitter shall be fully compatible with thermocouples and RTDs being provided by the contractor. Temperature compensation of the thermocouples shall be performed in the temperature transmitter itself.</p> <p>a. Single Input Head mounted Temperature Transmitter</p> <p>These shall be suitable for mounting in the head of temperature element itself. The protection class of head of thermo well along with its plug-in connector shall be min. IP65.</p> <p>b. Single Input DIN-rail mounted Temperature Transmitter</p> <p>These shall be especially designed for DIN-rail mounting in JBs. The specifications of the JBs shall be same as indicated in Subsection-IV:17 (INST CABLE) with additional DIN-rails and IP 65 Protection class. This temperature transmitter shall be the ones which are specially designed for DIN-rail mounting with IP 20 protection class. These shall have terminals for input/output provided on front side when mounted on DIN-rail. Head mounted temperature transmitter with clamps to make it suitable for DIN-rail mounting shall not be acceptable under this category.</p> <p>c. Dual-input Temperature Transmitter With Indicator:</p> <p>The dual-input TTs shall be suitable for mounting in enclosures/racks and shall be provided with clamps. Indicator shall be provided with these transmitters. These transmitters shall have bump less change over facility to</p>		
<p>VINDHYACHAL SUPER THERMAL POWER PROJECT STAGE-V (1X500 MW) FLUE GAS DESULPHURISATION (FGD) SYSTEM PACKAGE</p>	<p>TECHNICAL SPECIFICATION SECTION-VI BID DOCUMENT NO.: CS-2260-109-2</p>	<p>PART-B SUB-SECTION-III-C2 MEASURING INSTRUMENTS</p>	<p>Page 9 of 12</p>

CLAUSE NO.	TECHNICAL REQUIREMENTS		
	<p>second sensor in case first sensor fails .This change-over is to be alarmed. Protection class shall be IP65 minimum.</p> <p>d. Common requirements for each of the above type of temperature transmitters</p> <p>Output : 2-wire (power supply from input card of Control System) with 4-20mA output with superimposed HART protocol signal.</p> <p>Input : Same transmitter shall be capable to handle Pt-100 RTD , Thermocouples -K&R types (input type to be selectable at site through HART terminal)</p> <p>Isolation : min. 500 V AC</p> <p>EMC compatibility : as per EN 61326</p> <p>Operating ambient temperature : 0 to 85 deg C (without indicator) 0 to 70 deg C (with indicator)</p> <p>Power supply compatible with input module of Control System</p> <p>Accessories Mounting arrangements including clamps etc.</p> <p>Composite (a) For head mounted and DIN-rail mounted</p> <p>Accuracy types:</p> <p>(Refer note 2) RTD =<0.4% of 0-250 deg C span T/C-K type =<0.4% of 0-600 deg C span T/C-R type =<0.4% of 0-1000 deg C span</p> <p>CJC accuracy (for thermocouples) shall be =< 1 deg C</p> <p>(b) For dual-input type:</p> <p>RTD =<0.25% of 0-250 deg C span T/C-K type =<0.2% of 0-600 deg C span CJC accuracy (for thermocouples) shall be =< 1 deg C</p>		
<p>VINDHYACHAL SUPER THERMAL POWER PROJECT STAGE-V (1X500 MW) FLUE GAS DESULPHURISATION (FGD) SYSTEM PACKAGE</p>	<p>TECHNICAL SPECIFICATION SECTION-VI BID DOCUMENT NO.: CS-2260-109-2</p>	<p>PART-B SUB-SECTION-III-C2 MEASURING INSTRUMENTS</p>	<p>Page 10 of 12</p>

CLAUSE NO.	TECHNICAL REQUIREMENTS																														
<p>9.00.00</p> <p>9.01.00</p>	<p>SPECIFICATION FOR FLOW ELEMENTS</p> <p>Orifice Plate</p> <hr/> <table border="0"> <thead> <tr> <th data-bbox="386 359 841 411">Features</th> <th data-bbox="844 359 1414 411">Essential/Minimum Requirements</th> </tr> </thead> <tbody> <tr> <td>Type</td> <td>Concentric as per ASME PTC-19.5 (Part-II), ISA RP-3.2, 1960 or BS-1042</td> </tr> <tr> <td>Material</td> <td>316 SS</td> </tr> <tr> <td>Thickness</td> <td>3 mm for main pipe diameter up to 300 mm and 6 mm for main pipe dia above 300 mm.</td> </tr> <tr> <td>Material of branch pipe</td> <td>Same as main pipe</td> </tr> <tr> <td>Root valve type</td> <td>Globe</td> </tr> <tr> <td>Root valve material</td> <td>316 SS</td> </tr> <tr> <td>Root valve size</td> <td>1 inch</td> </tr> <tr> <td>Impulse pipe of same material up to root valve</td> <td>Required</td> </tr> <tr> <td>Tappings</td> <td>Flanged weld neck. 3 pairs. of tapping.</td> </tr> <tr> <td>Beta Ratio</td> <td>0.34 to 0.7</td> </tr> <tr> <td>Beta Ratio calculation to be submitted</td> <td>Yes</td> </tr> <tr> <td>Assembly drg. and flow Vs DP Curves</td> <td>Yes</td> </tr> <tr> <td>Accessories</td> <td>Root valves, flanges, Vent/drain hole (As required)</td> </tr> </tbody> </table> <p>Contractor shall submit certified flow calculation and differential pressure vs. flow curves for each element for Employer's approval. Sizing calculation, precise flow calculation for all the flow elements, fabrication and assembly drawings and installation drawings shall be submitted for Employer's approval. One Flow element of each type shall be calibrated in the test laboratory for validation of computed flow calculations.</p>			Features	Essential/Minimum Requirements	Type	Concentric as per ASME PTC-19.5 (Part-II), ISA RP-3.2, 1960 or BS-1042	Material	316 SS	Thickness	3 mm for main pipe diameter up to 300 mm and 6 mm for main pipe dia above 300 mm.	Material of branch pipe	Same as main pipe	Root valve type	Globe	Root valve material	316 SS	Root valve size	1 inch	Impulse pipe of same material up to root valve	Required	Tappings	Flanged weld neck. 3 pairs. of tapping.	Beta Ratio	0.34 to 0.7	Beta Ratio calculation to be submitted	Yes	Assembly drg. and flow Vs DP Curves	Yes	Accessories	Root valves, flanges, Vent/drain hole (As required)
Features	Essential/Minimum Requirements																														
Type	Concentric as per ASME PTC-19.5 (Part-II), ISA RP-3.2, 1960 or BS-1042																														
Material	316 SS																														
Thickness	3 mm for main pipe diameter up to 300 mm and 6 mm for main pipe dia above 300 mm.																														
Material of branch pipe	Same as main pipe																														
Root valve type	Globe																														
Root valve material	316 SS																														
Root valve size	1 inch																														
Impulse pipe of same material up to root valve	Required																														
Tappings	Flanged weld neck. 3 pairs. of tapping.																														
Beta Ratio	0.34 to 0.7																														
Beta Ratio calculation to be submitted	Yes																														
Assembly drg. and flow Vs DP Curves	Yes																														
Accessories	Root valves, flanges, Vent/drain hole (As required)																														
<p>VINDHYACHAL SUPER THERMAL POWER PROJECT STAGE-V (1X500 MW) FLUE GAS DESULPHURISATION (FGD) SYSTEM PACKAGE</p>	<p>TECHNICAL SPECIFICATION SECTION-VI BID DOCUMENT NO.: CS-2260-109-2</p>	<p>PART-B SUB-SECTION-III-C2 MEASURING INSTRUMENTS</p>	<p>Page 11 of 12</p>																												

CLAUSE NO.	TECHNICAL REQUIREMENTS																																												
9.02.00	<p>Flow Nozzle</p> <hr/> <table border="0" data-bbox="386 289 1414 1392"> <thead> <tr> <th data-bbox="386 289 846 342">Features</th> <th colspan="2" data-bbox="846 289 1414 342">Essential/Minimum Requirements</th> </tr> </thead> <tbody> <tr> <td data-bbox="386 342 846 447">Type</td> <td colspan="2" data-bbox="846 342 1414 447">Long radius, welded type as per ASME PTC-19.5 (Part-III) or BS-1042</td> </tr> <tr> <td data-bbox="386 447 846 510">Material</td> <td colspan="2" data-bbox="846 447 1414 510">316 SS</td> </tr> <tr> <td data-bbox="386 510 846 573">Thickness</td> <td colspan="2" data-bbox="846 510 1414 573">Suitable for intended application.</td> </tr> <tr> <td data-bbox="386 573 846 636">Material of branch pipe</td> <td colspan="2" data-bbox="846 573 1414 636">Same as main pipe</td> </tr> <tr> <td data-bbox="386 636 846 699">Root valve type</td> <td colspan="2" data-bbox="846 636 1414 699">Globe</td> </tr> <tr> <td data-bbox="386 699 846 762">Root valve material</td> <td colspan="2" data-bbox="846 699 1414 762">316 SS</td> </tr> <tr> <td data-bbox="386 762 846 825">Root valve size</td> <td colspan="2" data-bbox="846 762 1414 825">1 inch</td> </tr> <tr> <td data-bbox="386 825 846 930">Impulse pipe of same material up to root valve</td> <td colspan="2" data-bbox="846 825 1414 930">Required</td> </tr> <tr> <td data-bbox="386 930 846 993">Tapping</td> <td colspan="2" data-bbox="846 930 1414 993">D and D/2 (3 Nos. of tappings)</td> </tr> <tr> <td data-bbox="386 993 846 1056">Beta Ratio</td> <td colspan="2" data-bbox="846 993 1414 1056">Around 0.7</td> </tr> <tr> <td data-bbox="386 1056 846 1161">Beta Ratio calculation to be submitted</td> <td colspan="2" data-bbox="846 1056 1414 1161">Yes</td> </tr> <tr> <td data-bbox="386 1161 846 1266">Assembly drg. and flow Vs DP Curves</td> <td colspan="2" data-bbox="846 1161 1414 1266">Yes</td> </tr> <tr> <td data-bbox="386 1266 846 1392">Accessories</td> <td colspan="2" data-bbox="846 1266 1414 1392">Root valves, vent and drain hole.</td> </tr> </tbody> </table> <hr/> <p data-bbox="386 1423 1414 1623">Contractor shall submit certified flow calculation and differential pressure vs. flow curves for each element for Employer's approval. Sizing calculation, precise flow calculation for all the flow elements, fabrication and assembly drawings and installation drawings shall be submitted for Employer's approval. One Flow element of each type shall be calibrated in the test laboratory for validation of computed flow calculations.</p>			Features	Essential/Minimum Requirements		Type	Long radius, welded type as per ASME PTC-19.5 (Part-III) or BS-1042		Material	316 SS		Thickness	Suitable for intended application.		Material of branch pipe	Same as main pipe		Root valve type	Globe		Root valve material	316 SS		Root valve size	1 inch		Impulse pipe of same material up to root valve	Required		Tapping	D and D/2 (3 Nos. of tappings)		Beta Ratio	Around 0.7		Beta Ratio calculation to be submitted	Yes		Assembly drg. and flow Vs DP Curves	Yes		Accessories	Root valves, vent and drain hole.	
Features	Essential/Minimum Requirements																																												
Type	Long radius, welded type as per ASME PTC-19.5 (Part-III) or BS-1042																																												
Material	316 SS																																												
Thickness	Suitable for intended application.																																												
Material of branch pipe	Same as main pipe																																												
Root valve type	Globe																																												
Root valve material	316 SS																																												
Root valve size	1 inch																																												
Impulse pipe of same material up to root valve	Required																																												
Tapping	D and D/2 (3 Nos. of tappings)																																												
Beta Ratio	Around 0.7																																												
Beta Ratio calculation to be submitted	Yes																																												
Assembly drg. and flow Vs DP Curves	Yes																																												
Accessories	Root valves, vent and drain hole.																																												
<p>VINDHYACHAL SUPER THERMAL POWER PROJECT STAGE-V (1X500 MW) FLUE GAS DESULPHURISATION (FGD) SYSTEM PACKAGE</p>	<p>TECHNICAL SPECIFICATION SECTION-VI BID DOCUMENT NO.: CS-2260-109-2</p>	<p>PART-B SUB-SECTION-III-C2 MEASURING INSTRUMENTS</p>	<p>Page 12 of 12</p>																																										

**PERFORMANCE TEST PROCEDURE OF GATE / Bi-Plane DAMPER
(On FLOW)**

PROJECT : NTPC VINDHYACHAL , Unit-13 (R549)

Rev.	Date	Description	Sign



**EDC-DP,GATES & DAMPERS
BHARAT HEAVY ELECTRICALS LIMITED**

Boiler Auxiliaries Plant

RANIPET – 632 406

Date	Prepared	Reviewed	Approved
13-10-2014	 Masabattula Suresh	 V. Kesavan	 D. Ashwin Dhinakar

1. Scope

This procedure deals with the Test set up, methodology and calculations involved in type testing of Gate / Damper for establishing the leak tightness of Gate / Damper used in pressurized systems.

2. Reference documents

- 2.1 Corresponding Drawings
- 2.2 Approved Quality Plan

3. General

- 3.1 The Gate & Flap damper shall be tested in vertical position and the damper shall be tested in horizontal position Approved Quality Plan.
- 3.2 The Gate / Damper shall be operated for a minimum of five (5) times, before testing.
- 3.3 One operation is defined as from fully closed position to fully open position and back to fully closed position.
- 3.4 Upon completion of testing, the Gate / Damper shall be visually inspected for any physical damage to its components.

4. Test Procedure

- 4.1 Equipment requirement for type test is detailed out and the arrangement of the test equipment shall be as shown in the Annexure – II & III when they are to be tested without using seal air and as per Annexure – IV & V when they are to be tested with seal air.
- 4.2 The Gate / Damper (Item No. 01) shall be kept closed.
- 4.3 Energize the pressurizing fan (Item No. 02) and by adjusting the by-pass valve (Item No. 06) set the plenum duct (Item No. 04) pressure to the Gate / Damper pressure at MCR condition by using pressure tap (Item No. 07) and U Tube Manometer / Digital manometer.
- 4.4 Measure and record the velocity head at Pitot tubes (Item No. 08). Minimum three readings will be taken in each measurement and average will be recorded. Readings will be tabulated as per Annexure –I.
- 4.5 Using the formulae given in clause 5.0, calculate the leakage flow rate and estimate the degree of leak tightness of Gate / Damper.

4.6 If Seal Air is applicable, the same shall be connected and leakage will measured and calculated with Seal Air as per the step 4.3 to 4.5. Refer test set up drawings, Annexure – IV & V)

5 Calculations

Variables

Q_s	-	Volumetric flow rate of medium at MCR	m^3/sec
D	-	ID of connecting pipe	mm
T	-	Temperature	deg C
P_{st}	-	Plenum Chamber Pressure (static)	mm WC
V_p	-	Velocity head	mm WC
d	-	Density of air	kg/m^3
A	-	Connecting duct area of Cross section	m^2
V	-	Velocity	m/sec
Q	-	Flow rate (leak rate)	m^3/sec

$$V = \frac{4.4222 \times K \times \sqrt{V_p}}{d}$$

Where V	-	Velocity of air in m /sec
V_p	-	Velocity head in mm of WC measured in pitot tube
K	-	Constant for single point reading (0.91 for single point reading)
d	-	Air density (kg/m^3) at test temperature and pressure.

$$d = \frac{1.225 \times (288.5)}{(273 + T^{\circ}C)} \times \frac{(10335 + P_{st})}{10335}$$

$$Q = A \times V$$

$$\% \text{ Leakage} = \frac{\text{Leakage flow (Q)}}{\text{Flow rate of medium at MCR}} \times 100$$

Correction for Temperature & Pressure:

$$Q_1 = Q \times (d/d_1)$$

Where,

Q_1 - Leak rate of medium at specified temperature & pressure

d_1 - Density of medium at specified temperature & pressure

Percentage Leak at site condition, $L_S = (Q_1/Q_S) \times 100$

Therefore Leak Tightness at site, $LT_S = (100 - L_S)\% = (1 - Q_1/Q_S) \times 100\%$

Equipment List

Item No.	Description
01	Typical Gate / Damper : Gate / Damper to be tested
02	Pressurizing Fan sized to provide air supply at rated pressure to the plenum duct (Item No. 04) for testing.
03	Connecting pipe to connect pressurizing fan and plenum duct.
04	Plenum Duct to apply pressure to the Gate / Damper
05	Thermometer to measure the Temperature.
06	Bypass Valve mounted on the connecting duct to regulate the pressure in the plenum duct.
07	Pressure Tap provided to measure the air pressure in the plenum duct.
08	Pitot tube to measure velocity head.
09	Seal Air Blower (In case of testing using seal air supply. Refer Annexure- IV & V)

Annexure – I

LEAKAGE TEST OF GATE / BIPLANE DAMPER / FLAP DAMPER						
Project :			Size :			
WO No :			Test Date :			
			Time :			
Measured Values	Unit	Test 1	Test 2	Test 3	Test 4	Test 5
Pressure (Atm),PB	mbar					
Wet bulb temp, tw	°C					
Dry bulb temp, td	°C					
Track temp, T	°C					
Plenum chamber st. pr, Pst	mmWC					
Track static pr, Pst- track	mmWC					
Track dynamic pr, Vp	mmWC					
Area of track, A	m ²					
Seal air Pr	mmWC					
Calculated Values						
Volume flow thro' gate (MCR) Qs	m ³ /s					
Density (site), d1	kg/ m ³					
Air density (test), d	kg/ m ³					
Air velocity, V	m/s					
Volume leak (test), Q	m ³ /s					
% of leak tightness (test)	%					
Volume leak (site),Q1	m ³ /s					
% of leak tightness (site)	%					
Tested by :			Witnessed by :			

ALL DIMENSION ARE IN MM
DRAWING NOT TO SCALE

PAGE-8

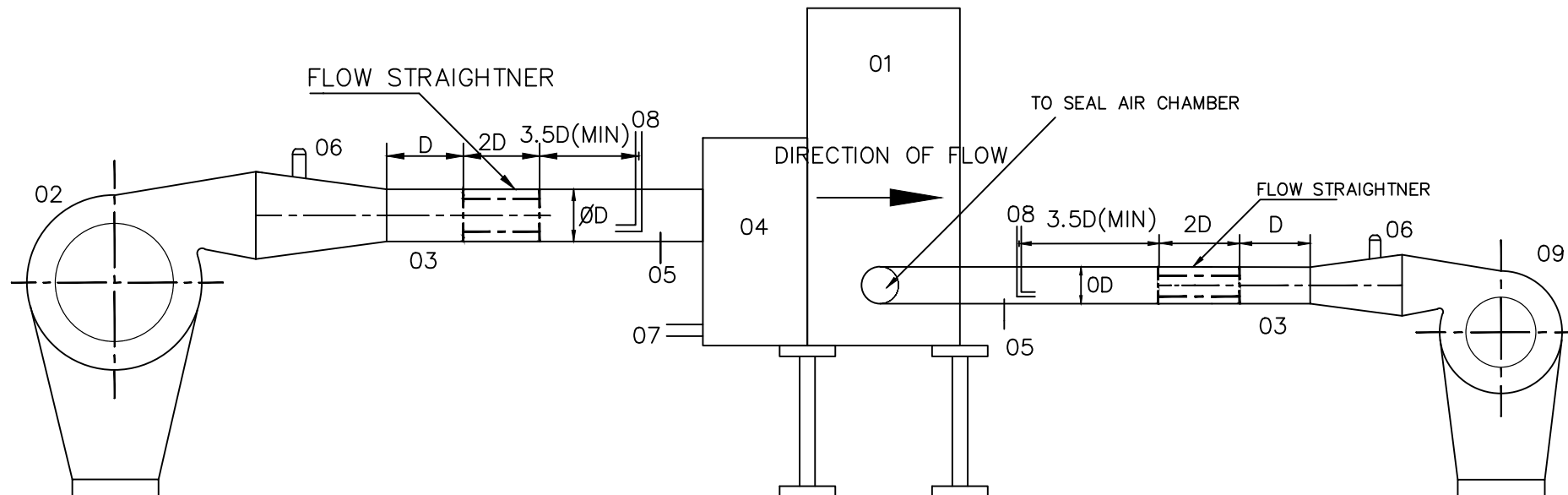

TIEM NO	ITEM NAME
01	GATE
02	PRESSURISING FAN
03	CONNECTING TRACK
04	PLENUM CHAMBER
05	THERMOMETER
06	BY PASS VALVE
07	PRESSURE TAP
08	PITOT TUBE
09	SEAL AIR BLOWER

 Bharat Heavy Electricals Ltd UNIT: BOLIER AUXILIARIES PLANT RANIPET - 632 406 355-052		TITLE TEST SETUP FOR GUILLOTINE GATE WITH SEAL AIR BLOWER		
DRAWN	APPROVED.	DATE	DRAWING NO :	REV
A. NATARAJ	M. THAGAVEL	06.03.12	ANNEXURE-IV	00

ALL DIMENSIONS ARE IN MM
DRAWING NOT TO SCALE

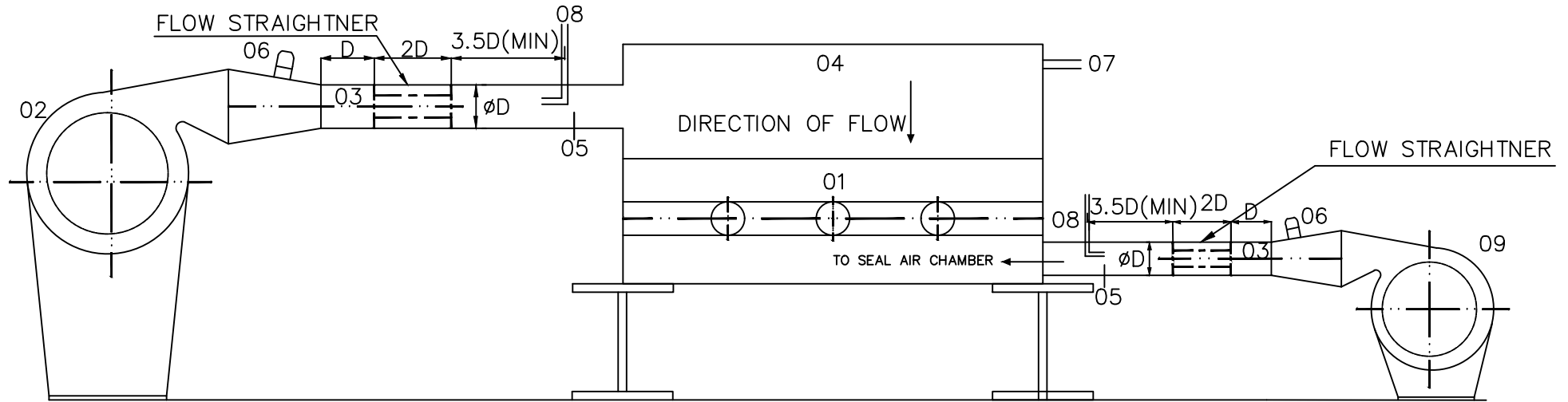

TIEM NO.	DESCRIPTION
01	DAMPER
02	PRESSURISING FAN
03	CONNECTING TRACK
04	PLENUM CHAMBER
05	THERMOMETER
06	BY PASS VALVE
07	PRESSURE TAP
08	PITOT TUBE
09	SEAL AIR BLOWER

 Bharat Heavy Electricals Ltd UNIT: BOLIER AUXILIARIES PLANT RANIPET - 632 406 <small>355-052</small>	TITLE: TEST SETUP FOR BI-PLANE DAMPER WITH SEAL AIR BLOWER			
	DRAWN	APPD	DATE:	DRAWING NO :
A. NATARAJ	M. THAGAVEL	06.03.12	ANNEXTURE-V	00

Project: VINDHYACHAL – 1 x 500MW (R549)

Qty/Boiler: 1 No

SL.No	Description	Outlet gate Requirement	Vendor Comments / Acceptance / Deviations
01	Duct inside dimension in mm (horizontal width(W) x vertical height(H))	6000(W) x 12007(H)	
02	Flow direction	Horizontal	
03	Duct material & thickness - mm	S-TEN1, 9 mm	
04	Outer casing thickness	9 mm or above. Vendor to mention	
05	Frame depth flange to flange (mm)	Vendor to specify	
06	Design & Operating pressure - mm of water column	Design ± 660 & Operating 40 (approx)	
07	Design Temperature	200°C	
08	Operating Temperature	FGD in service (Damper Closed) Upstream : 145°C Downstream : 100 to 105°C	
		FGD Bypassed (Damper Open) Upstream : 145°C Downstream : 145°C	
09	Velocity in m/sec	13	
10	Blade material	Upstream side	Vendor to specify
		Downstream side	SS317LMN or better/C276 cladding of 1.6 mm thickness
11	Frame material	Upstream side	Vendor to specify
		Downstream side	S-Ten1 /A36 lined with 5 mm thick SS317LMN or better / 1.6 mm thick C276 cladding
12	All seal material	ASTM B575 UNS N10276	
13	Damper Construction	Modular / Combination of split & modular vendor to specify	
14	Shaft material (To be suitable for Sulfuric acid corrosion resistance)	vendor to specify	
15	Damper Sealing efficiency without / with seal air (Volumetric flow method)	99.50 % / 100%	
16	Seal air system	2 x 100% (1 working + 1 standby blower)	
17	Seal air supply – Only Damper close position or continuously	Vendor to specify if seal air is required in Open position or	

	required	blower can be switched off.	
18	Blower mounting & seal air piping arrangement	Vendor to provide GA drg.	
19	Seal air volumetric flow (CFM) & pressure (mm WC) at i) Blower & ii) Damper frame inlet	Vendor to specify	
20	Blower motor rating in KW Blower Make & Model no.	Vendor to specify	
21	Damper Actuator Make& Model No. SMART Positioner Make& Model no.	Vendor to specify	
22	Actuation timings	a) Normal open /close timing without intermediate stops > 60 seconds	
		b) Quick open timings < t seconds (t should be adjustable between 10 to 20 seconds)	
23	Intermediate closing / opening positions	a)(i) First 40% closing (ii) Next 40% closing (iii) Final 20% closing	
		b) Opening is in the reverse order of above closing	
24	Air consumption for one operation (Open to close / close to open) in m ³ /sec for i) Normal operation & ii)Quick opening	Vendor to specify	
25	Integral limit switches at the actuator	Pair of limit switches shall be provided at open & Close positions and continuous position feedback of 4 -20 mA to achieve intermediate opening positions	
26	Actuator mounting with drive shaft	Vendor to specify	
27	Heater and related instrumentation for seal air – Make, Model no. & Rating KW	Vendor to specify	
28	Pressure switch – Make & Model no. Circuitry type Contacts rating	Vendor to specify Heavy duty DPDT (2NO+2NC) Continuous rating of 10A at 250V AC/ 0.1 A at 250V DC	

29	Auxiliary Power consumption in KW when FGD is in operation (Damper closed condition) i) Seal air Blower ii) Seal air Heater Considering ambient air temp of 27°C & 60% Relative humidity and heated to 130°C.	Vendor to specify	
29	Weight of Assembled Damper with all Accessories in kg	Vendor to specify	

VENDOR SIGNATURE :

SEAL:

PI-57583

PROFORMA INVOICE / PRICE BID for FGD BYPASS DAMPER

PROJECT : NTPC Vindhyachal #13 – 1 x 500 MW (R549) , ENQUIRY NO:_____

The scope of supply shall mandatorily cover the following items and the "Quantities" indicated against each item description in the table.

Sl. No.	ITEM DESCRIPTION	Unit Rate	Enquiry Quantity	Total Price
1	FGD Bypass Damper with mating flanges, Pneumatic Actuators and accessories as per specification GDRS: 018, Clause no. 3.0 & 19.0		1 set	
2	Mandatory spares consisting of : i) 1 no. Pneumatic actuator for the damper ii) 1 set of seals (set means for complete replacement of all damper(s) applicable in 1 duct of size 6m x 12.007m)		1 set	
3	Leak tightness type test charges (on Volumetric flow) as per GDRS: 018, clause no. 12.0		1	
4	Erection & commissioning support as per clause no. 6.2, 6.3 & 16.0 of GDRS: 018		1	
5	Grand Total price for above scope (sl nos. 1 to 4)			

Note:

In unpriced PRICE BID, bidder has to indicate "Quoted" against the columns "Unit Rate" and "Total Price" in above Table. The numerical values (Price) for all the above to be quoted in "price bid" only. No conditional clause shall be inserted into price bid by bidder. Any conditions added in price bid will cause rejection of bidder's offer. Certified that all items indicated in above table are covered in scope of supply.

BIDDER's SIGNATURE :

BIDDER's SEAL :

CHECKLIST for FGD BYPASS Bi-Plane Damper (Vindhyachal 500 MW, R549)

(Vendor shall submit this checklist duly filled along with Technical offer)

Sl. no:	DOCUMENTS	Furnished status / Confirmation (Yes/No)
1	Filled up Data sheets - DS-57583	
2	Comments /Acceptance/Deviations against the General specification as per GDRS: 018	
3	Proforma Invoice – PI-57583 filled and enclosed and all items as per cl.no.3.0 of GDRS: 018 included in scope of supply.	
4	Mandatory spares (Pneumatic Actuator & set of seals) price considered in the proforma Invoice PI-57583	
5	Leak tightness test charges considered in the proforma Invoice PI-57583 for one damper	
6	Erection and commissioning support charges confirming to cl.nos. 6.2, 6.3 & 16.0 in Technical specification GDRS: 018 First visit - for erection, second visit - 2 days for commissioning considered in Proforma Invoice PI-57583, sl.no.4	
7	Scope of supply clearly indicating terminal points & exclusions.	
8	General arrangement drawing enclosed with Technical offer showing: a) Overall Dimensions of Damper with all accessories with BOM, b) Material of construction, c) Split / modular details , d) Seals arrangement on all the four sides , e) Blade construction detail & f) weight details.	
9	i) Quality plan in line with BHEL QP & ii) filled up NTPC format no. QS-01-QAI-P-04/ F2-R1 (7 pages) enclosed	
10	Spares list quoted & valid for a period of 3 years: a) Commissioning spares b) Recommended spares for three years trouble free operation	
11	Reference list details & G.A. drawings satisfying the Qualification Requirements enclosed as per cl. No. 14.0 (c) & (d) of GDRS: 018	
12	Vendor confirmation for submission of specified drawing / document for approval (as specified in the general specification GDRS: 018 clause no. 21.2, 21.3 & 21.4) after placement of purchase order	
13	Bidder's confirmation of leak tightness testing to meet $\geq 99.50\%$ efficiency without seal air and 100% with seal air by volumetric flow method and as per enclosure G&D:LTTP (7 pages)	
14	Confirmation to painting requirement as per PS VINDHYACHAL R549 REV.00 .dt. 16.08.2012 (1 page)	
15	Confirmation that Damper proposed is of Modular(dismantlable)/ combination of Split & Moduar design for transportation & Assembly at site as per GDRS:018, Clause no. 6.1.	
16	Confirmation that all Instrumentation as specified in GDRS: 018 & BHEL P&ID : 4610-101-05RP and Inst_Spec-57583 are supplied in vendor scope.	
17	Confirmation that Electrical Heater and Blower can be switched off when the Damper Blades are in Open condition (FGD not in operation) and none of the flue gas exposed parts will be subject to corrosion (as per cl. No. 20.0 (A))	