



Boiler Auxiliary Plant , Bharat Heavy Electricals
Limited , Ranipet Tamilnadu- 632406

Purchase Department

Enquiry No: BAP/PUR/PB & TB/9550653E dt.12.08.2015
Due on:08.09.2015

Item : Plain Bearing and Thrust Bearing

Synopsis :

(i) Annexure-I

- (a) Pre-Qualification Requirement
- (b) Rate contract terms and conditions
- (b) Description of item , R/C Quantity details , Drawing and Relevant specification

(ii) Annexure-II: General terms and conditions of the tender.

(iii) Annexure-III: Commercial terms and conditions Annexure, MSME split provision & CA certificate format.

Contact Details

Shri. T Venugopal
Sr Manger/Purchase
Email : tvgopal@bhelrpt.co.in
Phone : 04172- 284621
Fax : 04172-241131

Shri. Biswajit Rath
Engineer / Purchase
Email : biswajit@bhelrpt.co.in
Phone : 04172-284007
Fax : 04172-241131

Annexure-I To Open Tender ref: BAP/PUR/PB & TB/9550653E dt.12.08.2015
For Supply Of “Plain Bearing ” & “Thrust Bearing” , Due on : 08.09.2015
Pre-Qualification Requirement

01. The bidder shall have experience of having successfully executed general fabrication of mild steel components and have successfully manufactured and supplied as per applicable codes and standards and shall submit the reference for BHEL review. The Vendor shall furnish at least one job order executed/under execution for steel fabrication specific requirement of the offered job.
02. The manufacture/supplier must be having their own fabrication shed with adequate plants and machineries to carry out the general fabrication to manufacture and supply of the indented items to ensure quality product with timely delivery. Details such as a) Address b) Contact Person etc. of the should be furnished.
03. The Manufacturer must submit copies of Work Order/ Purchase Order and Client's certificate detailing about (i) Time of Completion, (ii) Quality of Work & (iii) Value of work completed for the general fabrication the bidder manufactured and supplied.
04. The bidder should procure raw materials from the reputed sources and should be able to furnish the test certificates.
05. The bidder should employ the skilled man power as required for the intended component manufacturing meeting design drawing requirements.
06. The bidder should have necessary quality procedures/quality plans in place to ensure component quality.
07. The bidder should have all required plant and machineries (Viz Welding, Grinding, Drilling, Press of required capacity, Machining, Electrode oven etc.) in house to ensure complete manufacturing and supply of the intended component.
08. Offers of the Vendor/Supplier not agreeing/failing to submit required documents to any of the above will be liable for rejection.

Annexure-I To Open Tender ref: BAP/PUR/PB & TB/9550653E dt.12.08.2015
For Supply Of “Plain Bearing ” & “Thrust Bearing” , Due on : 08.09.2015
Rate Contract terms and conditions

Tender will be processed Through Rate contract with validity of 01 year from the date of Rate Contract LOI/PO.

1. Rate shall be firm and fixed till completion of supplies.
2. The framework agreement shall be valid for one year from the date of finalization of LOI/PO.
3. Separate addendum will be issued against firm requirement as and when requirement is there.
4. Framework Agreement quantity is tentative. No minimum qty is guaranteed.
5. Applicable duties and taxes shall be quoted extra separately.
6. BHEL reserves the right for performance monitoring, quality surveillance at supplier's end and short closing of contract.

Annexure-I To Open Tender ref: BAP/PUR/PB & TB/9550653E dt.12.08.2015

For Supply Of "Plain Bearing" & "Thrust Bearing" , Due on : 08.09.2015

Description of Item, Qty, Drawing and Relevant Specification

Sl No	Description of Itrm	R/C (Qty)	Unit	Delivery Destination
01	942850500000 Plain Bearing As Per Drg: 6172-0066/Rev 03, Test Certificate Verification For Hardness and Dimensional Inspection. For Machined Surface Temp Rust Preventive oil Minimum DFT = 20 Micron. Other surfaces Red Oxide Zinc Chrome Primer To IS 2074 Minimum DFT= 25 Micron. Synthetic Enamel Finish Paint To IS 2932 Minimum DFT=20 Micron. (SHADE: SMOKE GREY)	22500	No	BHEL/Stores/Ranipet
02	940670600000 Thrust Bearing As Per Drg: 6172-0051/Rev 00 With TC Verification For Hardness & Dimensional Inspection. Temporary Rust Preventive Oil Minimum DFT=20 Micron.	1500	No	BHEL/Stores/Ranipet

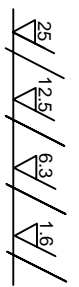

Note: 25 microns roughness is to be maintained wherever machining roughness are not indicated. 25 microns roughness is a raw material roughness obtained for a sand casting. If 25 microns is measured, no further machining is required on cast surface.

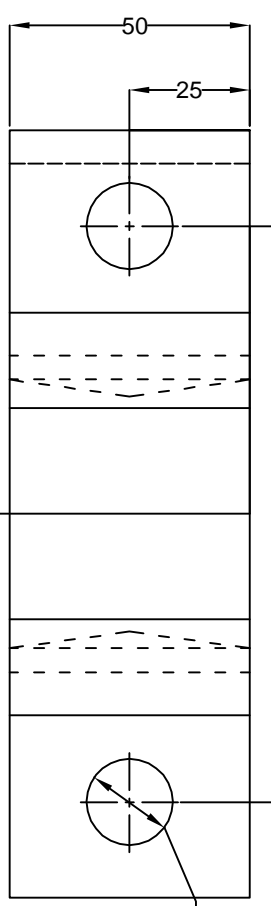
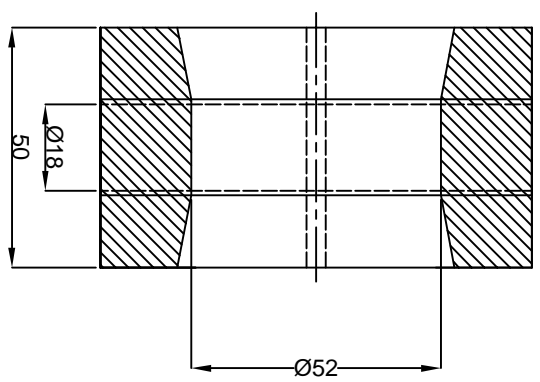
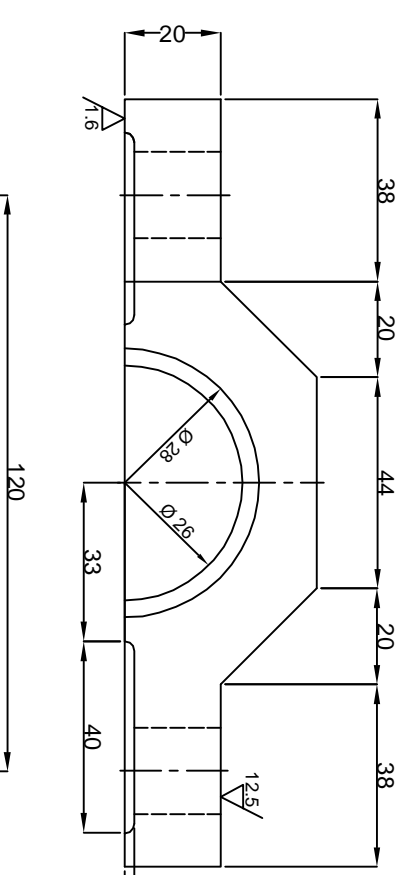
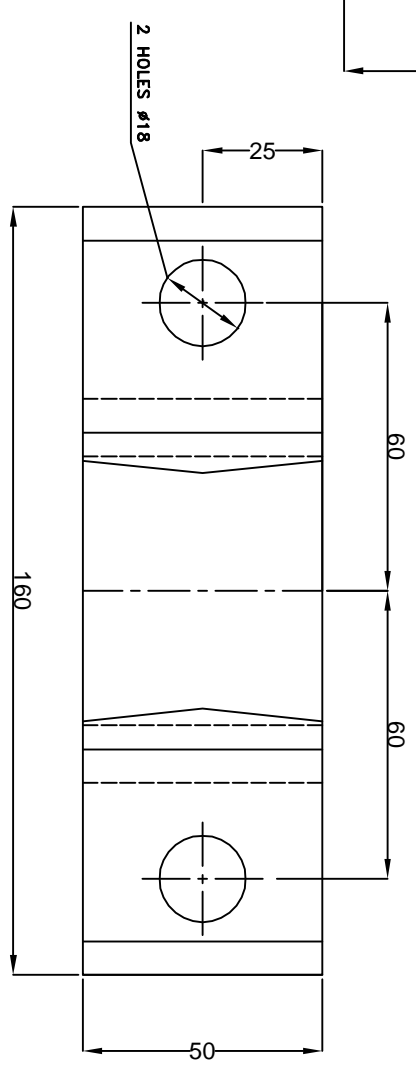
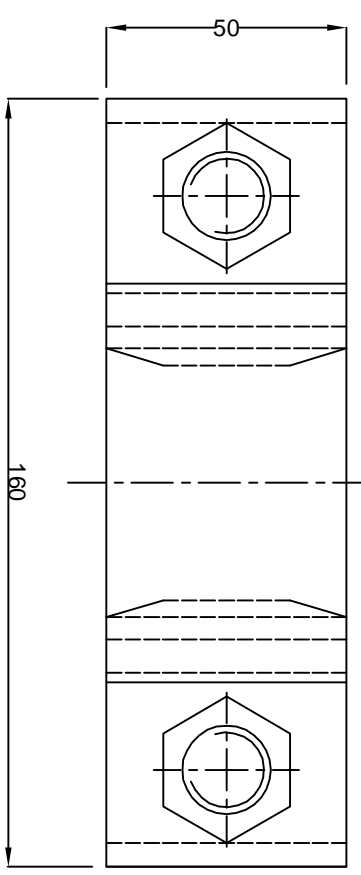
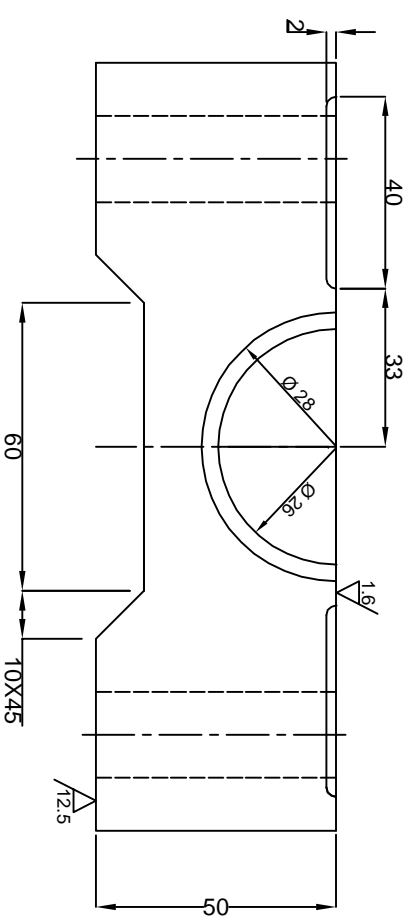
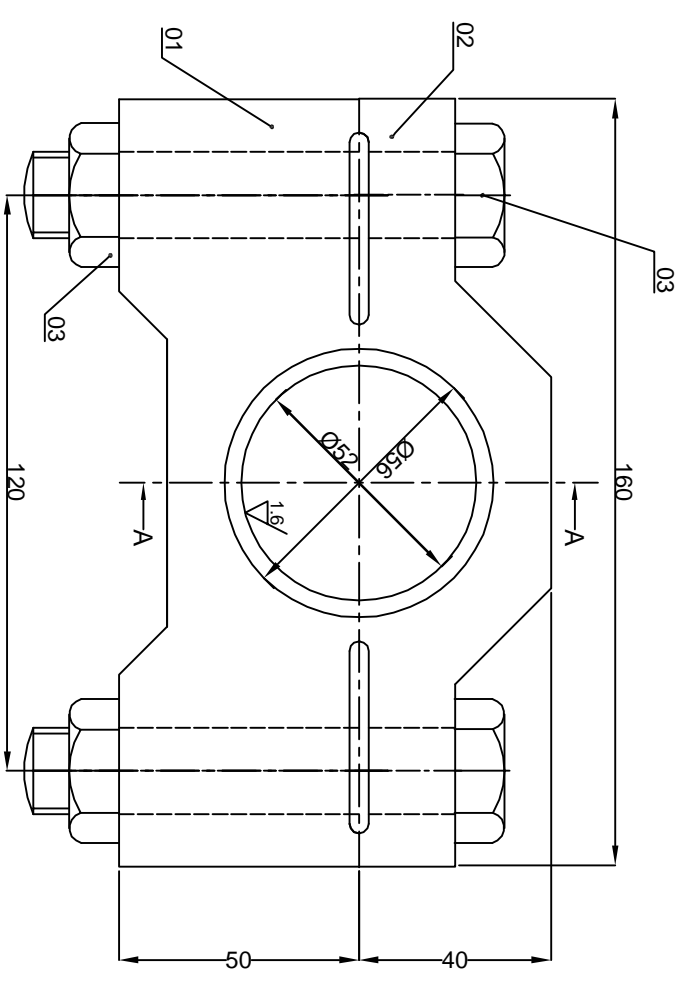

VAR No.	ITEM No.	DESCRIPTION	ES	DRAWING NO.	ITEM No.	MATL. CODE	UNIT WT.	QTY.	NO. OF ITEMS
	03	BOLT & NUT HEX GR. C 4.6 M16X100				412561610000	0.220	2	
	02	BEARING UPPER PART				92-005-605	1.085	1	
	01	BEARING LOWER PART				92-005-604	1.995	1	

REV	DATE	ALTERED	Address
03	15.08.14	CHECKED	C.Ganesh

REV	DATE	ALTERED	Address
02	25.03.2014	CHECKED	C.Ganesh
01	08.05.98	CHECKED	C.Ganesh

CAUTION: The information on this document is the property of BHARAT HEAVY ELECTRICALS LTD. It must not be used directly or indirectly in any way detrimental to the interest of the company.

TYPE OF PRODUCT OR NAME OF CUSTOMER/PROJECT

BHARAT HEAVY ELECTRICALS LTD.
 UNIT: BOILER AUXILIARIES PLANT.
 RAIPUR - 832 406.

DEPT ACSS GRADE OF UNTOLODIM SCALE WEIGHT (KG) CARD CODE

CODE 987 S/M/R N.T.S 3.520 U 01

TITLE **PLAIN BEARING**

NAME Address SIGN DATE

C.Ganesh C.Ganesh 28MAR2014

REF. TO ASSY/OLD DRG. 2-79-025-00259/01

DRAWING NO. **6172-0066**

NO. OF ITEMS **03**

FIRST ANGLE PROJECTION (ALL DIMENSIONS IN MILLIMETRE)

REV 01	DATE	ALTERED	REV 02	DATE	ALTERED
		CHECKED			CHECKED

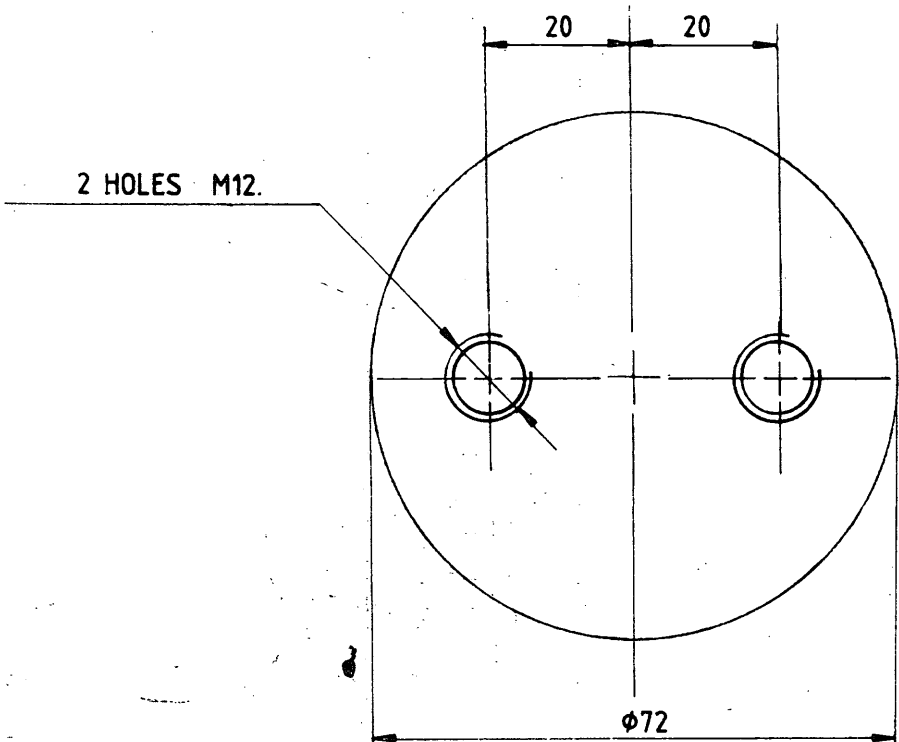
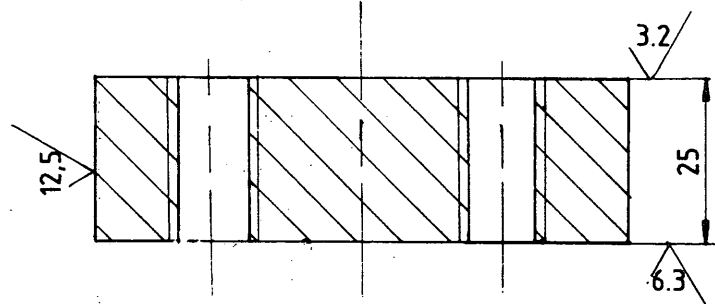
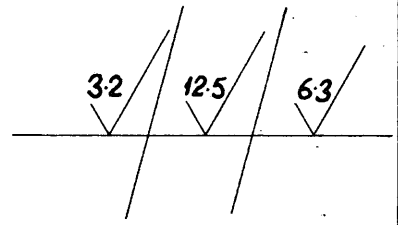

CAUTION THE INFORMATION ON THIS DOCUMENT IS THE PROPERTY OF BHARAT HEAVY ELECTRICALS LTD. IT MUST NOT BE USED DIRECTLY OR INDIRECTLY IN ANY WAY DETRIMENTAL TO THE INTEREST OF THE COMPANY

01	GREY IRON CASTING PAT. NO. 47901600161.	6172 0051 21	94 067 060 IS 210 Gr. 25.		0.79
VAR NO.	DESCRIPTION	BPS CODE	MATL. CODE	A/C	UNIT WT.
			MATL. SPEC.	UNIT	QTY.



Bharat Heavy Electricals Ltd.,
BOILER AUXILIARIES PROJECT
RANIPET 632 406.

DRN	NAME KJA	SIGN	DATE SEP '86
CHD			
APPD.	SN		

DEPT STD CODE 867	GRADE OF UNTOL DIM C/M/F		SCALE NTS	WEIGHT (KG) 0.79	REF TO ASSY/OLD DRG 4-79-016-00161./00.	ITEM NO. -
----------------------------	--------------------------------	--	--------------	---------------------	--	------------------

TITLE THRUST BEARING	CARD CODE U 01	DRAWING NO. 6172 0051	REV. NO. 00
--------------------------------	----------------------	---------------------------------	--------------------------