

**Index**  
**For tender documents (Technical)**  
**Tender no B/4222/2014/4303V/1**

<b>Content</b>	<b>Page no. of pdf file</b>
<b>Annexure/ Drawing no 31611770021 rev 00</b>	<b>Pg. 2 to Pg. 4</b>
<b>QAP NO QP/QA/BI/QP/006 rev 04</b>	<b>Pg. 5 to Pg. 8</b>
<b>Specification HE57016 rev b</b>	<b>Pg. 9 to Pg. 37</b>

4

COPYRIGHT AND CONFIDENTIAL  
THE INFORMATION ON THIS DOCUMENT IS THE PROPERTY OF  
BHARAT HEAVY ELECTRICALS LIMITED. IT MUST NOT BE USED  
DIRECTLY OR INDIRECTLY IN ANY WAY DETERMINAL TO THE  
INTEREST OF THE COMPANY.

1200/L1191C

ON SHAWARO/level indicator

एक कोण प्रक्षेपण / FIRST ANGLE PROJECTION

CONDENSER AIR EVACUATION PACKAGE UNIT

1. DESIGN DATA:

- 1) No. of Units required per TG set : Two (2)
- 2) No. of Units normally working (Holding) : One (1)
- 3) No. of Units working during Start-up (Hogging) : Two (2)
- 4) All flanges should be to ANSIB16.5

Note: C.W. for Vacuum pump Heat Exchanger is same as that of Condenser.

2. CAPACITY OF PUMP (as per HEI):

- 1) Design capacity (Holding) : 30 SCFM at 1" Hg abs at condenser design ITD
- 2) Dry Air Quantity: 135 lbs/hr
- 3) Water vapour to saturate : 297 lbs/hr
- 4) Total mixture Quantity: 432 lbs/hr
- 5) Air+Steam mixture temperature: Sub-cooled by 4.17 °C
- 6) Volume to be evacuated (approx) : 2200 m<sup>3</sup>
- 7) Time for initial evacuation : As per HEI (condenser)
- 8) Hogging capacity each pump : 800SCFM (minimum)

3. MATERIAL OF CONSTRUCTION (FOR NORMAL WATER APPLICATION)

- 1) Main Vacuum Pump & Re-circulation Pump: Cast Iron (CG 9439, HT 250)/ASTM A48, CLASS-35
- Impeller : Carbon Steel, En-8 or better
- Shaft Sleeve : (If applicable) Nodular Iron/ASTM A536, Gr.65-45-12 or Better
- Stainless Steel
- 2) Heat Exchanger (Shell & Tube Type) Shell : Carbon Steel, SA285 Gr.C
- Tubes : Welded SS, TP 316
- Tube Plate : Carbon Steel, SA285 Gr.C
- Water Box (Channel) : Carbon Steel, SA285, Gr.C/ Cast Iron
- Tube plate & Water box inside should be epoxy coated.

Extra 20% Margin in area shall be provided  
Cooling Water Pressure drop shall be limited to 3.5 MWC

4. MATERIAL OF CONSTRUCTION (FOR SEA WATER APPLICATION)

- 1) Main Vacuum Pump & Re-circulation Pump: Cast Iron (CG 9439, HT 250)/ASTM A48, CLASS-35
- Impeller : Carbon Steel, En-8 or better
- Shaft Sleeve : (If applicable) Nodular Iron/ASTM A536, Gr.65-45-12 or Better
- Stainless Steel
- 2) Heat Exchanger (Shell & Tube Type) Shell : Carbon Steel, SA285 Gr.C
- Tubes : Welded TI, SB338, Gr.2
- Tube Plate : Titanium/ Ti-clad Steel
- Water Box (Channel) : Carbon Steel, SA285, Gr.C/ Cast Iron
- Water box & affected piping inside surfaces shall be suitably coated against Sea water application.

Extra 20% Margin in area shall be provided  
Cooling Water Pressure drop shall be limited to 3.5 MWC.  
Vendor to furnish calculation to prove 20% margin in area and 3.5 MWC CW Pressure drop.

5. SPECIAL REQUIREMENTS :

- I) CI 12.1 shall read as "... is required within 3-weeks after award of ..."
- II) In case of Air Ejector with Vacuum Pump, total package power consumption with Ejector operation and without Ejector operation shall be furnished.
- III) The vibration level of the unit shall conform to "Good" range as per VDI: 2056 (Criteria for assessing mechanical vibration of machines)
- IV) The tapping for LEVEL INDICATOR & LEVEL SWITCH for separator tank of vacuum pump should be separate and both (L & LS) should work independently.

6. Item S1.Nc.11(3) of Vac.pump datasheet (Appendix D) is to be treated as deleted.

The following requirement shall be met for various primary instruments :

- (a) All instrument shall be suitable for 0-55 deg.C, 0-95% RH and degree of protection: IP55.
- (b) Accuracy for pressure/ temp. gauges shall be ±1% of full scale deflection.
- (c) Temperature element shall be 4 wire PT-100, duplex, conforming to DIN: 437600 or equivalent.
- 7. Of the two vacuum pump packages, required per TG set (2x100% design), tube withdrawal space of heat-exchanger in one shall be from inlet end and in the other, from outlet end (as indicated below):

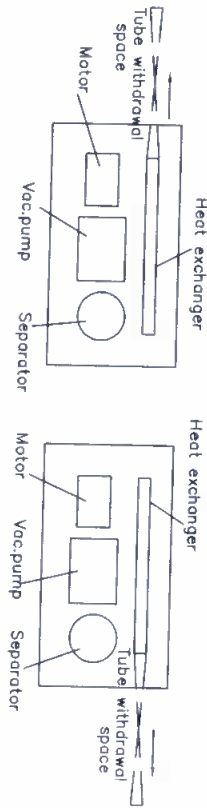

उत्पाद को प्रकार या ग्राहक/परियोजना का नाम  
TYPE OF PRODUCT OR NAME OF CUSTOMER/PROJECT  
30 SCFM VACUUM PUMP PACKAGE  
(CODE NO. W90716150204)

भाग DEPT. HXE	अनुभाग/SCALE	भार/वजन WEIGHT (KG)	कार्ड कोड CARD CODE
कॉड/कोड			
शीट/शीट			
ANNEX. TO HE57016			

क्र.सं./Sl. No.	नाम/NAME	आवृत्ति/SGN	दिनांक/DATE	सं. सं./No. of Ver.
1	SHIVA	Sd	01/12/14	
2	SHIVA	Sd	01/12/14	
3	SKANT	Sd	01/12/14	

शीट नं./DRAWING NO.	REV
31611770021	04
22	24

A3 शीट/A3 SIZE

शीट नं. (शीट)/FORM 38 (8)

सं. सं./INVENTORY NO.	ग्राहक और दिनांक/SGN & DATE	संदर्भ आरेख सं. सं./REFERENCE DRG. NO.
-----------------------	-----------------------------	--

संशोधित एवं गोपनीय  
यह प्रयोग में आने वाले दस्तावेज़ भारत भारती इलेक्ट्रिकल्स लिमिटेड की  
संपत्ति है। इसका प्रयोग या प्रकाशक रूप में किसी भी तरह  
प्रयोग नहीं किया जाए जो कंपनी के हित में हानिकारक हो।



5

L200L/11915

ON SHAWND/First Angle Projection

पहला कोण प्रक्षेपण / FIRST ANGLE PROJECTION

सर्व विमाएँ मिलिमीटर में हैं / ALL DIMENSIONS ARE IN mm.

फॉर्म क्र. 38 (अ) / FORM 38 (B)

# CONDENSER AIR EVACUATION SYSTEM

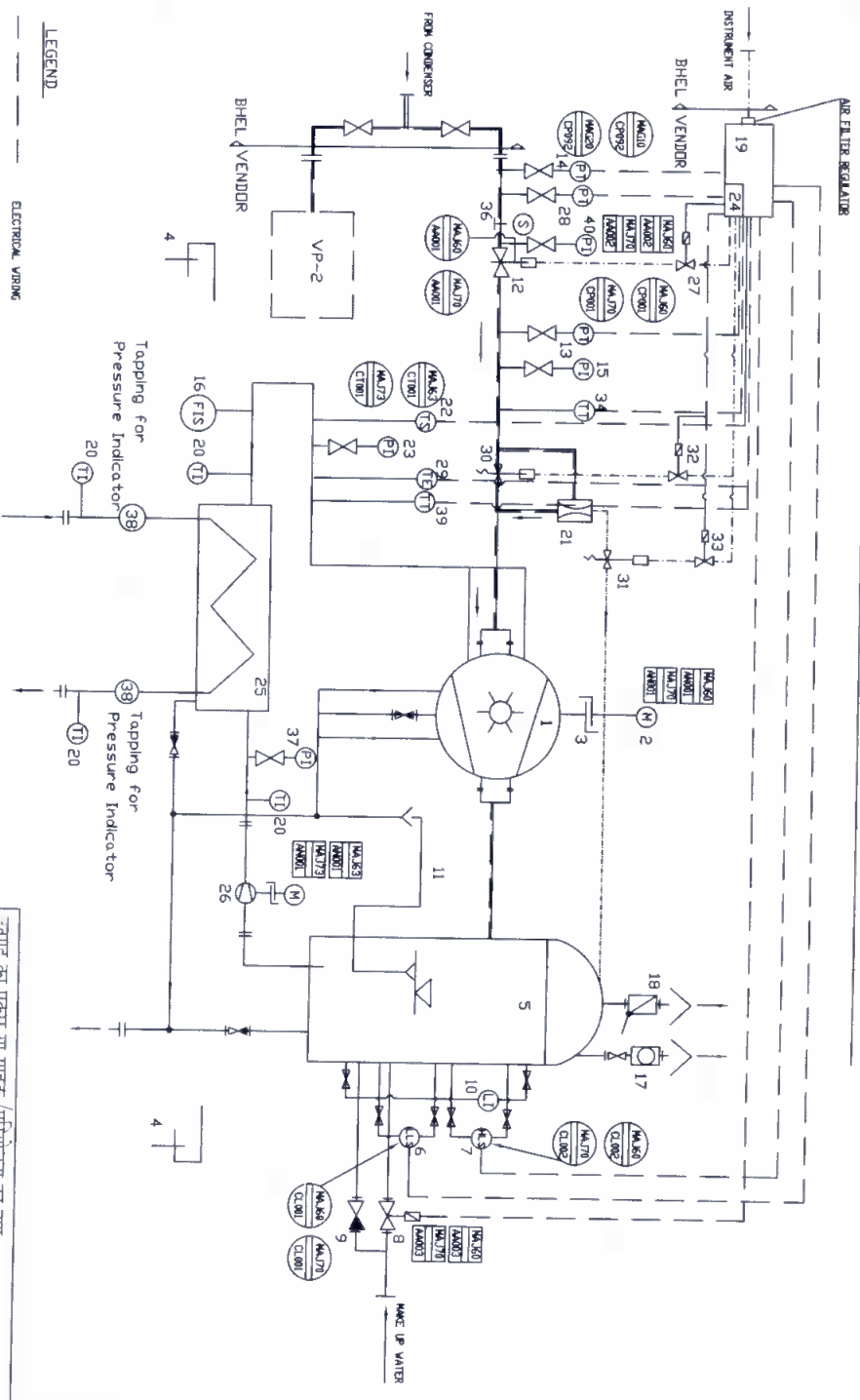

ITEM	DESCRIPTION
1.	VACUUM PUMP, 2-STAGE (OR 1-STAGE)
2.	MOTOR
3.	COUPLING
4.	FOUNDATION BOLT+NUT+WASHER
5.	SEPARATOR
6.	LOW LEVEL SWITCH WITH ISOLATION VALVE
7.	HIGH LEVEL SWITCH WITH ISOLATION VALVE
8.	MAKEUP WATER INLET VALVE
9.	MAKEUP WATER BYPASS VALVE
10.	LEVEL INDICATOR WITH ISOLATION VALVE
11.	OVERLEVEL SYPHON LOOP
12.	SYSTEM INLET VALVE WITH OPEN/CLOSE LIMIT SWITCH
13.	PRESSURE TRANSMITTER FOR INLET VALVE OPEN
14.	P.R. TRANSMITTER FOR STANDBY PUMP OPEN
15.	PRESSURE INDICATOR WITH VALVE
16.	SEAL WATER FLOW METER (ROTAMETER)
17.	AIR FLOW METER (ROTAMETER)
18.	AIR OUTLET CHECK VALVE WITH HANDLE
19.	JUNCTION BOX (GREEN DRG. NO.)
20.	TEMPERATURE INDICATOR
21.	EJECTOR (IF APPLICABLE)
22.	TEMPERATURE SWITCH
23.	PRESSURE INDICATOR WITH VALVE
24.	P.I.C. FOR EJECTOR (IF APPLICABLE)
25.	HEAT EXCHANGER
26.	SEAL WATER PUMP WITH MOTOR
27.	SOLENOID VALVE (24 V DC)
28.	P.R. TRANSMITTER FOR EJECTOR (IF APPLICABLE)
29.	TEMP. ELEMENT FOR SEAL WATER FOR EJECTOR (IF APPLICABLE)
30.	BY-PASS VALVE FOR EJECTOR (IF APPLICABLE)
31.	MOTIVE AIR VALVE FOR EJECTOR (IF APPLICABLE)
32.	SOLENOID VALVE (24V DC) FOR EJECTOR (IF APPLICABLE)
33.	SOLENOID VALVE (24V DC) FOR EJECTOR (IF APPLICABLE)
34.	TEMPERATURE TRANSMITTER IN SUCTION LINE
35.	-----
36.	TEMPORARY INLET SCREEN
37.	PRESSURE INDICATOR WITH VALVE
38.	TAPPING FOR PRESSURE INDICATOR
39.	TEMP. TRANSMITTER FOR SEAL WATER
40.	PRESSURE INDICATOR WITH VALVE

संशोधन और दिनांक/SIGN & DATE  
 संदर्भित डॉक्यूमेंट नम्बर REFERENCE DRG. NO.

NOTE: 1. THE GASKETS, FLANGES, CASSETS ETC. FOR FLANGED CONNECTIONS SHALL BE IN THE SCOPE OF VENDOR.  
 2. INLET NOZZLE (PROCESS INLET) CONNECTION TO BE MADE HORIZONTAL OR SUITABLE REDUCER AND BEND TO BE PROVIDED BY VENDOR.

LEGEND  
 ----- ELECTRICAL WIRING  
 ----- AIR PIPING  
 ----- AIR & STEAM MIXTURE PIPING  
 ----- WATER PIPING

उत्पाद का प्रकार या ग्राहक/परियोजना का नाम TYPE OF PRODUCT OR NAME OF CUSTOMER/PROJECT  
**30 SCFM VACUUM PUMP PACKAGE**

विकासकर्ता/DESIGNER	SHIVA	दिनांक/DATE	01/12/14
ड्राफ्ट्समैन/DRAFTER	SHIVA	दिनांक/DATE	01/12/14
चेक/CHIEF	SKANT	दिनांक/DATE	01/12/14

भारत हेवी इलेक्ट्रिकल्स लिमिटेड, रानीपुर, हरियाणा  
 BHARAT HEAVY ELECTRICALS LIMITED,  
 RANIPUR, HARYANWAR

भाग/SCALE WEIGHT (KG)  
 अनुपात/SCALE

शीट/TITLE  
**PID - CONDENSER AIR EVACUATION SYSTEM**

कार्ड कोड/CARD CODE  
**31611770021**

श्री/क्रमांक/REV  
 22 23 24

A3 शीट/A3 SIZE

5

<b>BHEL</b>		<b>MANUFACTURERS NAME &amp; ADDRESS</b>				<b>INSPECTION AND TEST PLAN</b>				PROJECT : ENNORE PACKAGE: TG	
		ITEM: Vacuum Pump Unit				QP NO. QA/BI/QP/006				CONTRACT NO.:	
		SUB-SYSTEM:				REV.: 04				CONTRACTOR: BHEL	
		TYPE OF CHECK				DATE: 06.06.12				FORMAT OF RECORD	
		CLASS				PAGE: Page 1 of 4				M C N	
Sf. No		CHARACTERISTICS		QUANTUM OF CHECK		REFERENCE /ACCEPTANCE NORMS		D		REMARKS	
1.		3.		4.		5.		6.		7.	
2.		4.		5.		6.		8.		9.	
3.		5.		6.		7.		8.		9.	

Sf. No	COMPONENT / OPERATION	CHARACTERISTICS	CLASS	TYPE OF CHECK	QUANTUM OF CHECK	REFERENCE /ACCEPTANCE NORMS	FORMAT OF RECORD	AGENCY	REMARKS						
1.	2.	3.	4.	5.	6.	7.	8.	M C N	9.						
1.	MAIN PARTS FOR VACUUM PUMP • CASING • IMPELLER • SHAFT	CHEMICAL & MECHANICAL PROPERTIES	MAJOR	CHEMICAL & MECHANICAL	PER HEAT	AS PER APPROVED DRAWING / DATASHEET	AS PER APPROVED DRAWING / DATASHEET	AS PER APPROVED DRAWING / DATASHEET	AS PER APPROVED DRAWING / DATASHEET	ASME VIII DIV 1 APPENDIX 7	TC	✓	P	V	NO WELD REPAIR PERMITTED
2.	PIPE / FITTINGS (For System Pipe Work)	EXAMINATION OF MACHINED SURFACES	MAJOR	VISUAL & DPT	100%	AS PER APPROVED DRAWING / DATASHEET	AS PER APPROVED DRAWING / DATASHEET	AS PER APPROVED DRAWING / DATASHEET	AS PER APPROVED DRAWING / DATASHEET	TC	TC	✓	P	V	
3.	PUMP BEARINGS	CHEMICAL & MECHANICAL PROPERTIES	MAJOR	CHEMICAL & MECHANICAL	100%	AS PER APPROVED DRAWING / DATASHEET	AS PER APPROVED DRAWING / DATASHEET	AS PER APPROVED DRAWING / DATASHEET	AS PER APPROVED DRAWING / DATASHEET	TC	COC	✓	P	V	
4.	IMPELLER	DIMENSIONS MAKE/TYPE	MAJOR	VISUAL	100%	AS PER APPROVED DRAWING / DATASHEET	AS PER APPROVED DRAWING / DATASHEET	AS PER APPROVED DRAWING / DATASHEET	AS PER APPROVED DRAWING / DATASHEET	TC	TC	✓	P	V	
5.	SHAFT	DYNAMIC BALANCING	MAJOR	BALANCING AT RATED SPEED	100%	VENDOR'S STD	VENDOR'S STD	VENDOR'S STD	VENDOR'S STD	TC	TC	✓	P	V	
4a.	HEAT EXCHANGER (TUBE / SHELL)	UT TEST	MAJOR	CHECK	100%	ASTM A 388	ASTM A 388	ASTM A 388	ASTM A 388	TC	TC	✓	P	V	
		VISUAL & DIMENSIONAL	MAJOR	MEASUREMENT / VISUAL	100%	VENDOR'S DRAWING	VENDOR'S DRAWING	VENDOR'S DRAWING	VENDOR'S DRAWING	TC	-	-	P	-	
		CHEMICAL &	MAJOR	CHEMICAL &	PER	APPROVED	APPROVED	APPROVED	APPROVED	TC	TC	✓	P	V	

MANUFACTURER/SUB CONTRACTOR		CONTRACTOR		FOR CUSTOMER		DOC NO.	
REVIEWED BY		APPROVED BY		REVIEWED BY		APPROVED BY	
C: CONTRACTOR / NOM		N: CUSTOMER		INDICATE 'P' PERFORM 'W' WITNESS AND 'V' VERIFICATION		ALL 'W' INDICATED IN COLUMN 'N' SHALL BE 'CHP' OF CUSTOMER	

*[Signature]*  
*[Signature]*  
 Smt/Vibhuti Shah  
 Smt/Vibhuti Engineer

Quality Assurance  
 BHEL Handwar

BHEL

MANUFACTURERS NAME & ADDRESS

INSPECTION AND TEST PLAN

PROJECT : ENNORE  
PACKAGE : TG

ITEM: Vacuum Pump Unit  
SUB-SYSTEM:

CONTRACT NO.:  
CONTRACTOR: BHEL

Sr No	COMPONENT / OPERATION	CHARACTERISTICS	CLASS	TYPE OF CHECK	QUANTUM OF CHECK	REFERENCE /ACCEPTANCE NORMS	FORMAT OF RECORD			REMARKS
							M	C	N	
1.	2	3	4	5	6	7.	8	9	10.	

QP NO.QA/BI/QP/006  
REV.: 04  
DATE: 06.06.12  
PAGE: Page 2 of 4

Sr No	COMPONENT / OPERATION	CHARACTERISTICS	CLASS	TYPE OF CHECK	QUANTUM OF CHECK	REFERENCE /ACCEPTANCE NORMS	FORMAT OF RECORD	AGENCY	REMARKS
								M C N	
		MECHANICAL PROPERTIES OF TUBES /TUBE SHEET / SHELL EDDY CURRENT TEST ON TUBES	MAJOR	ECT	100%	HEAT	DRAWING / DATASHEET		
		SOUNDNESS OF WELD	MAJOR	X RAY OF BUTT WELDS	10%	MECHANICAL	DRAWING / DATASHEET		
		HYDRAUSTATIC TEST	MAJOR	PRESSURE TEST SHELL & TUBE SIDES	100%	MECHANICAL	DRAWING / DATASHEET		
5.	MOTOR	IDENTITY ROUTINE TEST TYPE REPORT	MAJOR	VISUAL & MEASUREMENT TEST TEST	100% 100% 100%	MECHANICAL	DRAWING / DATASHEET		
6.	INSTRUMENTS TEMP / PRESSURE GAUGES	CALIBRATION AND ACCURACY	MAJOR	CALIBRATION	100%	MECHANICAL	DRAWING / DATASHEET		

FOR CUSTOMER		DOC NO.
REVIEWED BY	APPROVED BY	
LEGEND: ' RECORDS IDENTIFIED WITH 'TICK' SHALL BE ESSENTIALLY INCLUDED BY CONTRACTOR IN QA DOCUMENTATION '!' M: MANUFACTURER / SUBCONTRACTOR '!' N: CUSTOMER '!' I: INSPECTION AGENCY '!' W: WITNESS AND 'V' VERIFICATION ALL 'W' INDICATED IN COLUMN 'N' SHALL BE 'CHP' OF CUSTOMER		
MANUFACTURER/SUB CONTRACTOR	CONTRACTOR	

**Shah Vibhuti Shah**  
 Quality Assurance Engineer  
 Quality Assurance  
 BHEL Haridwar







PRODUCT STANDARD  
HEAT EXCHANGER ENGINEERING

HE 57016

PAGE 1 OF 29

THIS SUPERSEDES THE OLD STANDARD UNDER THE SAME NUMBER

TECHNICAL SPECIFICATION  
CONDENSER AIR EVACUATION UNIT

SIGN & DATE

SUPERSEDES INVENTORY NO.

COPYRIGHT AND CONFIDENTIAL  
The information on this document is the property of BHARAT HEAVY ELECTRICALS LIMITED. It must not be used directly or indirectly in any way detrimental to the interest of the company.

1.0 SCOPE :

This specification covers the design, manufacture, inspection, performance testing, painting and packing of mechanical vacuum pumps alongwith drive motor, control instruments and accessories, to be used for evacuation of air and other non-condensable gases with associated water vapour, from surface type steam condenser for power plant application, during hogging and holding operations.

2.0 CODES AND STANDARDS :

The design, manufacture, inspection, performance testing, painting and packing of main pump and accessories should be proven and to well known international standards like Pneurop 6612, HEI-Performance Standard for Liquid Ring Vacuum Pumps etc. (bidder to specify the code number in his offer).

Sizing of the main pump shall be as per HEI-Standards for Steam Surface Condensers, unless otherwise specified in the Annexure.

3.0 DESIGN REQUIREMENTS :

3.1 The mechanical vacuum pumps and accessories shall be used for continuous duty, to create and maintain vacuum by removing air and other non-condensable gases with associated water vapour, from the steam condenser during the power plant operation. Final selection should consider compatible operation of the condenser and the pump over the full range of anticipated condenser operating pressures as indicated in the Condenser Performance Curves enclosed in the Annexure. The selection of design parameters for vacuum pump and its accessories and condenser design conditions are given in the Annexure.

SIGN & DATE

4-10-93

INVENTORY NO.

P-5778

AGREED		NAME	SIGN & DATE
		DRAWN	VIMAL 7.9.93
TSX	P.S. Saxena	WORKED	N.S. 7.9.93
QAX	S.S. Chauhan	CHECKED	N.P.M. 11.9.93
DEPT.	NAME	SUPERVISED	V.K.S. 11.9.93
REV.	DATE	Distribution	Qty
Approved: A. SINGH			HE
SR.DGM (HXE)			8.30
Prepared	Issued HXE HARDWAR	Date 28-9-93	



**PRODUCT STANDARD**  
**HEAT EXCHANGER ENGINEERING**

**HE 57016**

PAGE 2 OF 29

SIGN & DATE

SUPERSEDES INVENTORY NO.

COPYRIGHT AND CONFIDENTIAL

The information on this document is the property of BHARAT HEAVY ELECTRICALS LIMITED. It must not be used directly or indirectly in any way detrimental to the interest of the company.

SIGN & DATE

4-10-93

INVENTORY NO.

P. 5778

3.2 The pumps shall be of single stage or two stage liquid ring type with suitable compression ratio, to meet the conditions specified in the Annexure and the Condenser Performance Curves, ensuring no cavitation under all operating conditions. Bidder shall indicate the arrangement being offered to avoid cavitation.

~~3.3 The pump in operation should have a minimum recommended capacity of 40 % of the free dry air capacity as specified in the Annexure, at 0.5" Hg abs. suction pressure and a saturated temperature of 51.3 deg F.~~

3.4 The pumps shall be of liquid ring design with both the stages (if it is a two stage pump) mounted on a common shaft. The unit shall require no external lubrication and shall not be damaged by ~~water droplets or slugs of water and entrained gases.~~

3.5 Each pump unit with the accessories shall be furnished as a package unit mounted on a common steel base plate.

3.6 The pumps shall be connected to its motors by flexible couplings. All couplings shall have suitable rigid steel coupling guards having closed ends and anchored to the base plate.

3.7 Each vacuum pump unit shall include, but not be limited to, the items listed under SCOPE OF SUPPLY in Appendix-D and <sup>indicated on</sup> the SYSTEM FLOW DIAGRAM at Appendix-A. The bidder shall furnish his flow diagram covering complete Scope of Supply.

3.8 Provision shall be made in the design of the equipment to prevent loss of vacuum by flow of atmospheric air back into the condenser upon shut down of the pump.

3.9 The design pressure to be considered for the cooling water circuit is 5.0 kg/sq.cm g and for the make-up water circuit as 45 kg/sq.cm g. The source of make-up and sealing water is D.M.water. (condensate quality).

3.10 It shall be sufficient for the owner to connect air and water terminal points to a common Terminal Block and the wiring to the motor's terminal boxes. Shut down drains must be terminated at one point with the valve.

REV.	b	s			WKD. BY	N.SANYAL	<i>[Signature]</i>	7.9.93
SIGN. & DATE	<i>[Signature]</i>	15/10/93			CHD. BY	N.P.MATHUR	<i>[Signature]</i>	14-9-93



**PRODUCT STANDARD**  
**HEAT EXCHANGER ENGINEERING**

**HE 57016**

PAGE 3 OF 29

SIGN & DATE

INVENTORY NO.

COPYRIGHT AND CONFIDENTIAL  
The information on this document is the property of BHARAT HEAVY ELECTRICALS LIMITED. It must not be used directly or indirectly in any way detrimental to the interest of the company.

SIGN & DATE

INVENTORY NO.

3.11 All components including spares and spare assemblies (if any) of all the pumps and accessories shall be completely interchangeable.

3.12 The condenser air evacuation unit shall perform continuously without exceeding the noise level of 85 dBA at a distance of 1.0 metre from the unit for a surrounding of the inside of a turbine hall. Silencer shall be provided if required. The vibration levels of the pump unit shall conform to "good" range as per VDI-2056 (Criteria for assessing mech. vibr. of machines).

3.13 The materials of construction of all the parts including all accessories shall be suitable to the fluids being handled/used. The source of cooling water shall be as given in the Annexure. The materials of construction shall not be inferior to that specified in the Annexure.

3.14 Provision shall be made in Heat Exchanger to permit access to tubes without disturbing CW-piping connections. Tube size shall not be less than 5/8".

**4.0 CONTROL AND INTERLOCK REQUIREMENTS:**

Automatic Turbine Run up System (ATRS) is being used by purchaser for the turbine. Pump supplier has to supply all necessary fittings and accessories to enable ATRS to carry out following operations:

All process signals from the switches etc. (in pump supplier's scope) will be fed to ATRS and command/signals from ATRS shall be fed to the pump, motors, solenoids etc. (in pump supplier's scope) for carrying out required operations. For further details, refer ATRS/VACUUM PUMP INTER-FACE diagram at Appendix-B.

Bidder shall provide all the required instruments, devices, out puts, interfacing equipments etc. as required for completeness of his system and as required to make it compatible with the purchaser's ATRS. The exact requirement shall be finalised with the successful bidder while finalising the logic diagram.

The following operations shall be carried out through ATRS:

- a) Hogging operation for quick evacuation of condenser during turbine start up, upto a predetermined vacuum.
  - b) Automatic change over from hogging to holding operation at the preset vacuum.
  - c) Automatic starting of the standby unit in the event of fall in vacuum at a preset value.
- The range of pressure/vacuum switches selected should be suitable for the condenser operating condition.

REV.	b	z			WKD. BY	N.SAMYAL	<i>[Signature]</i>	7.9.93
SIGN. & DATE	<i>[Signature]</i>	<i>[Signature]</i>			CHD. BY	N.P.MATHUR	<i>[Signature]</i>	14-9-93

4-10-93

P-5778



**PRODUCT STANDARD**  
**HEAT EXCHANGER ENGINEERING**

**HE 57016**

PAGE 4 OF 29

SIGN & DATE

SUPERSEDES INVENTORY NO.

COPYRIGHT AND CONFIDENTIAL

The information on this document is the property of BHARAT HEAVY ELECTRICALS LIMITED. It must not be used directly or indirectly in any way detrimental to the interest of the company.

Control of anticavitation arrangement shall not be through ATRS. This must be a part of vacuum pump supply, self contained, and shall be mounted on the pump.

The operation of the cooling water inlet/outlet valves shall be manual (not in pump supplier's scope).

All pneumatic valves shall have limit switches for open and closed positions.

b) All switches shall be of 2-SPDT contacts. Repeatability for switches to be  $\pm 0.5\%$ .

**5.0 DRIVE MOTOR:**

5.1 Drive motor shall be furnished and mounted by the bidder on the pump unit and the complete assembly shipped as one unit. The horse power of the motor shall not be less than 110% of the maximum BHP required at the pump end.

5.2 Drive motors shall comply with the specification in Appendix-C.

**6.0 QUALITY REQUIREMENTS:**

The vendor shall prepare & submit detailed Quality Plan in the format prescribed, enclosed with the enquiry, for all items / components / equipments being manufactured / supplied by the vendor.

The Quality Plan will set-out various stages of manufacture, the quality practices & procedures to be followed by them, the relevant reference documents / standards, acceptance level, inspection records raised etc. The Quality Plan shall be approved by the owner. The owner shall identify customer-hold-points on the final Quality Plan beyond which work shall not proceed without owner's consent in writing. An indicative programme of inspection / test, envisaged by BHEL is given below. This is however not intended to form a comprehensive inspection & testing programme, as it is the vendor's responsibility to draw-up & carry-out necessary checks from operation, safety & reliability point of view.

**6.1 Tests:**

Following minimum tests shall be carried-out:

(a) All rotating parts of pumps shall be dynamically balanced as per ISO:1940, G 6.3.

SIGN & DATE

4-10-93

INVENTORY NO.

P-5778

REV.	b	i			WRD. BY	N. SANYAL	<i>[Signature]</i>	7.9.93
SIGN. & DATE	<i>[Signature]</i>	15/9/99			CHD. BY	N. R. MATHUR	<i>[Signature]</i>	14-9-93



PRODUCT STANDARD

HE 57016

HEAT EXCHANGER ENGINEERING

PAGE 5 OF 29

SIGN & DATE

SUPERVISOR'S INVENTORY NO.

COPYRIGHT AND CONFIDENTIAL  
The information on this document is the property of BHARAT HEAVY ELECTRICALS LIMITED. It must not be used directly or indirectly in any way detrimental to the interest of the company.

SIGN & DATE

4/10/93

INVENTORY NO.

P-5778

(b) Shafts shall be subjected to ultra-sonic test. After finish machining, shaft shall be subjected to magnetic particle / dye penetrate test.

(c) Pump casings & Heat Exchanger shall be subjected to hydraulic test at 1.5 times the design pressure or twice the maximum operating pressure.

(d) Tests to demonstrate ability to meet the guaranteed performance (refer clause V of Appendix-D). The tests must be conducted at rated speed and with its corresponding motor. Bidder to submit correction curves, based upon actual test data, if tests are not conducted at rated conditions.

(e) Saturated air performance test, to prove the capacity at guaranteed conditions and visual cavitation test (type tests) to be carried out. The test procedure for these tests shall be furnished to BHEL for review & approval. If such type tests are already carried out on same size and model pump earlier, test results and test procedures are to be submitted with the bid for BHEL's review & acceptance.

(f) Functional test of the package for demonstrating that the requisite functions/interlocks are being performed by the pump and all the accessories.

(g) Type & routine tests for motors as per Appendix-C. In case Type tests on motors are already carried out then the Test reports shall be furnished to BHEL along with the bid for review & acceptance information.

(h) Complete equipment and all accessories are subject to visual inspection and witnessing of performance tests by BHEL or its representative at bidder's works for which atleast 60 days advance notice shall be given by the bidder. Complete testing schedule must be furnished within 30 days of letter of intent.

(i) The minimum inspection and testing requirement shall conform to the relevant codes / standards, whether or not specifically mentioned in the specification. The bidder shall give full consideration to the observations of the inspecting agency regarding acceptance of workmanship and or equipment.

REV.	6	2			WKD. BY	N. SANYAL	<i>[Signature]</i>	7.9.93
SIGN. & DATE	<i>[Signature]</i>	15/2/93			CHD. BY	N. R. MATHUR	<i>[Signature]</i>	14-9-93



**PRODUCT STANDARD**  
**HEAT EXCHANGER ENGINEERING**

**HE 57016**

PAGE 6 OF 29

SIGN & DATE

SUPERSEDES INVENTORY NO.

COPYRIGHT AND CONFIDENTIAL  
 The information on this document is the property of BHARAT HEAVY ELECTRICALS LIMITED. It must not be used directly or indirectly in any way detrimental to the interest of the company.

SIGN & DATE

INVENTORY NO.

6.2 The bidder shall be responsible for all necessary tests during fabrication/manufacture and before shipment to ensure that the equipment meets the specification and will operate satisfactorily as an assembled unit. Approval or passing of test/inspection and thereby issue of test certificate or waiver of inspection by the inspection agency shall not relieve the bidder of his responsibilities and obligations under the contract as well as shall not bind BHEL to accept the equipment, should it, on further tests after erection, be found not complying with the contract.

6.3 The bidder shall furnish the list of customers to whom the offered model pump have been sold in the past along with dates of installation & commissioning of the units, MW rating of the Power Plants and the no. of pump units employed in each unit of the Power Plants.

**7.0 SPARES:**

**7.1 Start-up (erection & commissioning) spares:**

Bidder shall give separate offer for start-up spares with item-wise price break-up. Such spares shall be supplied alongwith the main pump order.

**7.2 Recommended spares:**

Bidder shall give separate offer for the recommended maintenance spares for five years of normal operation considering one set (two pump units), two sets and three sets basis respectively. Quantity recommended must be indicated separately according to the No. of sets under consideration. Details of spares, with item-wise price break-up, must be given with the offer.

**7.3 Mandatory spares:**

Bidder to quote unit price of the spares, if listed in the Annexure.

Note: Selected spares out of 7.2 & 7.3 above may be ordered simultaneously with the main order, or, at a later date, as may be decided by BHEL.

7.4 Each spare item shall be properly identified and marked as per spare order list and despatched in a separate packing box marked "SPARES".

4.10.93

P-5778

REV.	b	1				WKD. BY	N. SANYAL	<i>[Signature]</i>	7.9.93
SIGN. & DATE	<i>[Signature]</i>	12/2/93				CHD. BY	N.P. MATHUR	<i>[Signature]</i>	14-9-93



**PRODUCT STANDARD**  
**HEAT EXCHANGER ENGINEERING**

**HE 57016**

PAGE 7 OF 29

SIGN & DATE

SUPERSEDES INVENTORY NO.

COPYRIGHT AND CONFIDENTIAL  
 The information on this document is the property of BHARAT HEAVY ELECTRICALS LIMITED. It must not be used directly or indirectly in any way detrimental to the interest of the company.

SIGN & DATE

4/10-93

INVENTORY NO.

P-5778

**8.0 GUARANTEES:**

The bidder shall meet the guaranteed performance requirement as specified in clause V of Appendix-D.

**9.0 PACKING:**

Condenser air evacuation unit must be suitably packed to avoid any damage during handling and transport. Packing must be sea-worthy to avoid any damage/corrosion to all the parts during sea shipment. All the loose items should be properly tacked. Details of handling the package shall be clearly indicated on the packing box.

Packing list clearly indicating the items to be shipped in each package must be sent to BHEL, 2 months in advance. All the loose items and the items likely to be loosened during transit should be listed separately, to ensure the ~~supply to be completeness of supply.~~ <sup>(b)</sup>

Two copies of the <sup>inside</sup> ~~list of contents~~ <sup>packing</sup> must be put at safe places, one <sup>the</sup> ~~the~~ package and <sup>the other</sup> ~~outside~~ the package. <sup>(b)</sup>

**10.0 AFTER SALES SERVICE:**

Bidder shall extend free after sales service for the supplies made against this offer for a period of 5 years from the date of commissioning of the pump units. Bidder shall depute his engineer to the site in case of failure/malfunction of the equipment and auxiliaries, he has supplied against this specification. This will have no commercial implication from the bidder's side.

Bidder to indicate clearly the specific arrangement made by him for after sales service in India.

**11.0 DATA/DOCUMENT REQUIRED WITH THE BID:**

Bidder shall invariably furnish three copies of the following documents in English language:

11.1 General arrangement drawing of vacuum pump package showing overall dimensions, maintenance clearances required, mounting and connection details, weights-empty/operating/flooded/motor/bare pump, list of items with their location in the package unit, foundation bolts and their grouting details etc.

REV.	b	2			WKD. BY	N. SANYAL	<i>[Signature]</i>	7.9.93
SIGN. & DATE	<i>[Signature]</i>	15/10/93			CHD. BY	N. R. MATHUR	<i>[Signature]</i>	14-9-93



PRODUCT STANDARD  
HEAT EXCHANGER ENGINEERING

HE 57016

PAGE 8 OF 29

SIGN &amp; DATE

SUPERSEDES  
INVENTORY NO.

11.2 Sectional arrangement drawing of the pump showing all components with their material specn., numbers etc.

11.3 Flow diagram <sup>indicating terminal points and</sup> ~~showing~~ scope of supply with all the equipments/instruments/switches/valves etc. being supplied. <sup>⑥</sup>

11.4 Logic diagram showing sequence of operation, with the conditions to be fulfilled, from initial start to stand by pump start and stop.

11.5 Appendix-D & E, duly filled in for the pump & the motor data respectively.

11.6 Performance characteristic curves:

① a) Dry air capacity of pump (saturated with water vapour at 4.17°C under cooling) Capacity vs Suction Pressure, at rated speed and different ITDs <sup>of and</sup> around the rated ITD (saturation temperature corresponding to suction pressure minus CW inlet temperature to the heat exchanger).

b) Suction pressure vs Cooling water inlet temperature to heat exchanger, for different air leakage rates, covering atleast 2.5 times the design air handling capacity of the pump at 1"Hg abs. suction pressure.

c) Power consumption vs suction pressure at rated ITD. <sup>⑥</sup>

d) Time vs Vacuum, while evacuating the volume specified in the Annexure.

e) Dry air performance test curves and seal water temp. correction curves <sup>⑥</sup>

11.7 Saturated air test results and visual cavitation test results with procedure and scheme, if such tests are already carried out on proposed size & model pump.

11.8 Wiring diagrams for all devices connected to the terminal box for feedback to ATRS and control signals from ATRS, clearly showing the break-up of the scope of supply between the bidder and the purchaser (refer Appendix-B).

11.9 Bill of materials of all instruments (instrument schedule) alongwith the manufacturer's catalogues for critical items and also the recommended set point.

11.10 Complete list of feeder loads (power supply requirements for various drives) including solenoid valves. <sup>⑥</sup>

11.11 Reference list of past supplies as specified in clause 6.3 above.

COPYRIGHT AND CONFIDENTIAL  
The information on this document is the property of BHARAT HEAVY ELECTRICALS LIMITED. It must not be used directly or indirectly in any way detrimental to the interest of the company

SIGN &amp; DATE

A-10-93

INVENTORY NO.

P-5778

REV.

b

5

WKD. BY

N. SANYAL

7.9.93

SIGN. &  
DATE

15/2/99

CHD. BY

N. P. MATUR

14-9-93



**PRODUCT STANDARD**  
**HEAT EXCHANGER ENGINEERING**

**HE 57016**

PAGE 9 OF 29

SIGN & DATE

SUPERSEDES INVENTORY NO.

COPYRIGHT AND CONFIDENTIAL  
 The information on this document is the property of BHARAT HEAVY ELECTRICALS LIMITED. It must not be used directly or indirectly in any way detrimental to the interest of the company.

SIGN & DATE

04-10-93

INVENTORY NO.

P-5778

- 11.12 List of start up, recommended and mandatory (if specified in the Annexure) spares, with unit price and quantity installed per pump.
- 11.13 Quality Plan on BHEL format alongwith the testing procedures.
- 12.0 DATA/DOCUMENT AFTER AWARD OF ORDER:
- 12.1 Following data/document is required within 45 days after award of letter of intent in 20 copies per project:
  - 12.1.1 General arrangement drawing of the pump unit, along with a reproducible, as per clause 11.1 above.
  - 12.1.2 Sectional arrangement drawing as per clause 11.2 above.
  - 12.1.3 Flow diagram as per clause 11.3 above.
  - 12.1.4 Logic diagram as per clause 11.4 above.
  - 12.1.5 Appendix D & E, duly filled-in for the pump and the motor data respectively.
  - 12.1.6 Characteristic curves:
    - a) Performance characteristic curves as per clause 11.6 above.
    - b) Motor characteristic curves as per clause 4.0 of Appendix-E.
  - 12.1.7 General arrangement drawing of the motor indicating overall dimensions, weights (rotor, total), fixing details, rotor removal space etc..
  - 12.1.8 Foundation drawing clearly indicating loads on each foundation bolt (due to weight and dynamic loads), pocket size, foundation bolts etc., grouting required etc.
  - 12.1.9 Instrument schedule alongwith manufacturer's catalogues.
  - 12.1.10 List of feeder loads as per clause 11-10 above.
  - 12.1.11 General and sectional arrangement drawings of seal water recirculation pump & heat exchanger.

REV					WKD. BY	N. SANYAL	<i>[Signature]</i>	7.9.93
SIGN. & DATE					CHD. BY	N.P. MATHUR	<i>[Signature]</i>	14-9-93



**PRODUCT STANDARD**  
**HEAT EXCHANGER ENGINEERING**

**HE 57016**

PAGE 10 OF 29

SIGN & DATE

SUPERSEDES INVENTORY NO.

COPYRIGHT AND CONFIDENTIAL

The information on this document is the property of BHARAT HEAVY ELECTRICALS LIMITED. It must not be used directly or indirectly in any way detrimental to the interest of the company.

12.1.12 Wiring diagram as per clause 11.8 above.

12.1.13 General arrangement drawing and wiring diagram of anticavitation device (if provided).

**NOTE:** Exchange of technical information from the date of receipt of quotation till placement of order may warrant changes in drgs./data furnished during the bid; in such event "Preliminary data/documents" shall be furnished as per clause 12.0 above in 3 copies for our review/comments/approval within 2 weeks of LOI. Final data/documents (in 20 copies) to be supplied subsequently as per clause 12.0 above, after incorporating our comments, if any.

12.1.14 To assess progress at different stages of manufacturing, testing & despatch of equipment (major parts) spares, L2 network shall be furnished.

12.2 Quality assurance document package:

Following certificates/inspection reports, NDT reports (in 3 copies per pump) are required after test. Equipment should be despatched only after acceptance of the test certificates.

12.2.1 Material test certificates of ~~major parts e.g.~~ body, shaft, impeller, sleeves of main pump, and seal water pump, tubes, shell and water boxes of heat exchanger etc..

12.2.2 Hydraulic test certificates of main and seal water pumps, heat exchanger, valves etc..

12.2.3 Performance test results of seal water pump.

12.2.4 Performance test readings alongwith test set up and procedure for main vacuum pump with correction curves/factors and calculations to prove the capacity of the pump.

12.2.5 Routine and type test results of main and seal water pump motors.

12.2.6 Test certificates of ~~other fittings e.g.~~ all switches, solenoid valves, all valves, calibration certificates of all instruments.

12.2.7 Other certificates/reports as per approved quality plan.

SIGN & DATE

4-10-93

INVENTORY NO.

P-5778

REV.	6	3			WKD. BY	N. SANYAL		7-9-93
SIGN. & DATE	[Signature]				CHD. BY	N. P. MATHUR	[Signature]	14-9-93



**PRODUCT STANDARD**  
**HEAT EXCHANGER ENGINEERING**

**HE 57016**

PAGE 11 OF 29

SIGN & DATE

SUPERSEDES INVENTORY NO.

COPYRIGHT AND CONFIDENTIAL  
 The information on this document is the property of BHARAT HEAVY ELECTRICALS LIMITED. It must not be used directly or indirectly in any way detrimental to the interest of the company

SIGN & DATE

4-10-93

P-5778

**12.3 Operating and maintenance instructions:**

Bidder shall furnish 20 copies of operation and maintenance manual for the pump, motor and all the accessories under his scope, clearly indicating the models and sizes supplied with the unit, for each site/BHEL contract.

**13.0 ADDITIONAL TECHNICAL INFORMATION:**

**13.1 APPENDICES:** The following appendices, as referred in subsequent pages of this specification, are the integral part of this specification and shall be complied-with fully:

- APPENDIX-A : System Flow Diagram
- APPENDIX-B : ATRS/Vacuum Pump Interface
- APPENDIX-C : Induction Motor Specification
- APPENDIX-D : Vacuum Pump Data-Sheet
- APPENDIX-E : Motor Data-Sheet

**13.2 ANNEXURE:** The technical requirements relating to the specific design conditions, water chemistry, special material requirement of client, condenser performance curves, capacity or any other special requirement from the client shall be supplied as "ANNEXURE". This information would vary from contract to contract, and shall be treated as integral part of this specification.

To avoid any ambiguity, all the sheets of the ANNEXURE for each order/contract shall be identified as under:

ANNEXURE to HE57016 (-----*-----)	sheet-- of --
--------------------------------------	---------------

\* name of project shall be indicated here.

REV.					WKD. BY	N. SANYAL	<i>[Signature]</i>	7.9.93
SIGN. & DATE					CHD. BY	N.R. MATNUR	<i>[Signature]</i>	14-9-93



SIGN & DATE

SUPERSEDES INVENTORY NO.

COPYRIGHT AND CONFIDENTIAL  
The information on this document is the property of BHARAT HEAVY ELECTRICALS LIMITED. It must not be used directly or indirectly in any way detrimental to the interest of the company.

SIGN & DATE

P-5778  
4-10-93

SYSTEM FLOW DIAGRAM

APPENDIX-A

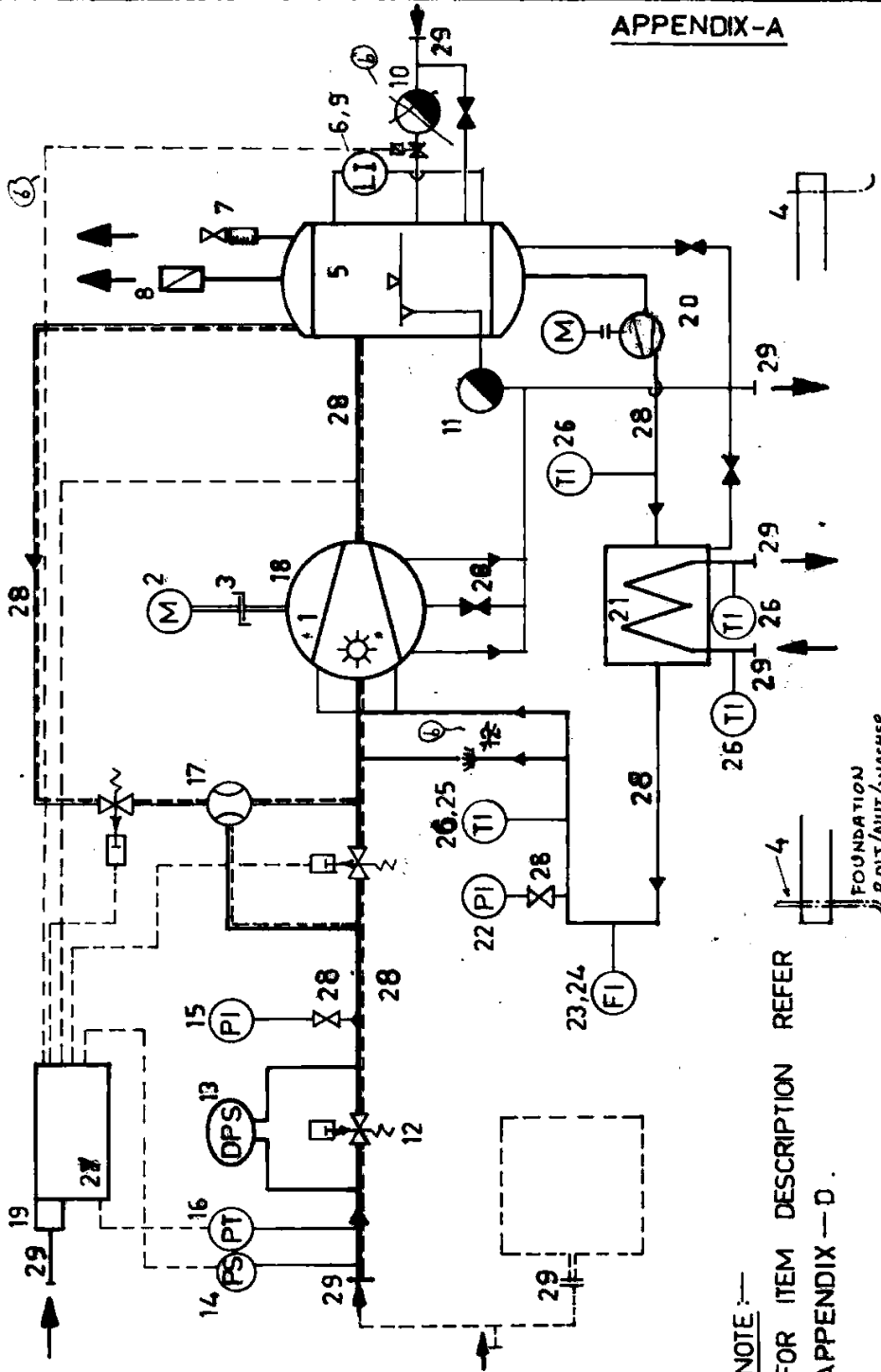

NOTE: --  
FOR ITEM DESCRIPTION REFER  
APPENDIX - D.

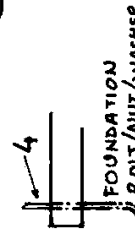

REV.	b	4	WKD. BY	N.SANYAL	7-9-93
SIGN. & DATE	<i>[Signature]</i>	5/2/93	CHD. BY	N.R.MATHUR	14-9-93



PRODUCT STANDARD  
HEAT EXCHANGER ENGINEERING

HE 57016

PAGE 13 OF 29

SIGN & DATE

SUPERSEDES INVENTORY NO.

COPYRIGHT AND CONFIDENTIAL  
The information on this document is the property of BHARAT HEAVY ELECTRICALS LIMITED. It must not be used directly or indirectly in any way detrimental to the interest of the company

SIGN & DATE

4-10-93

INVENTORY NO.

P-5778

ATRS / VACUUM PUMP INTERFACE

APPENDIX-B

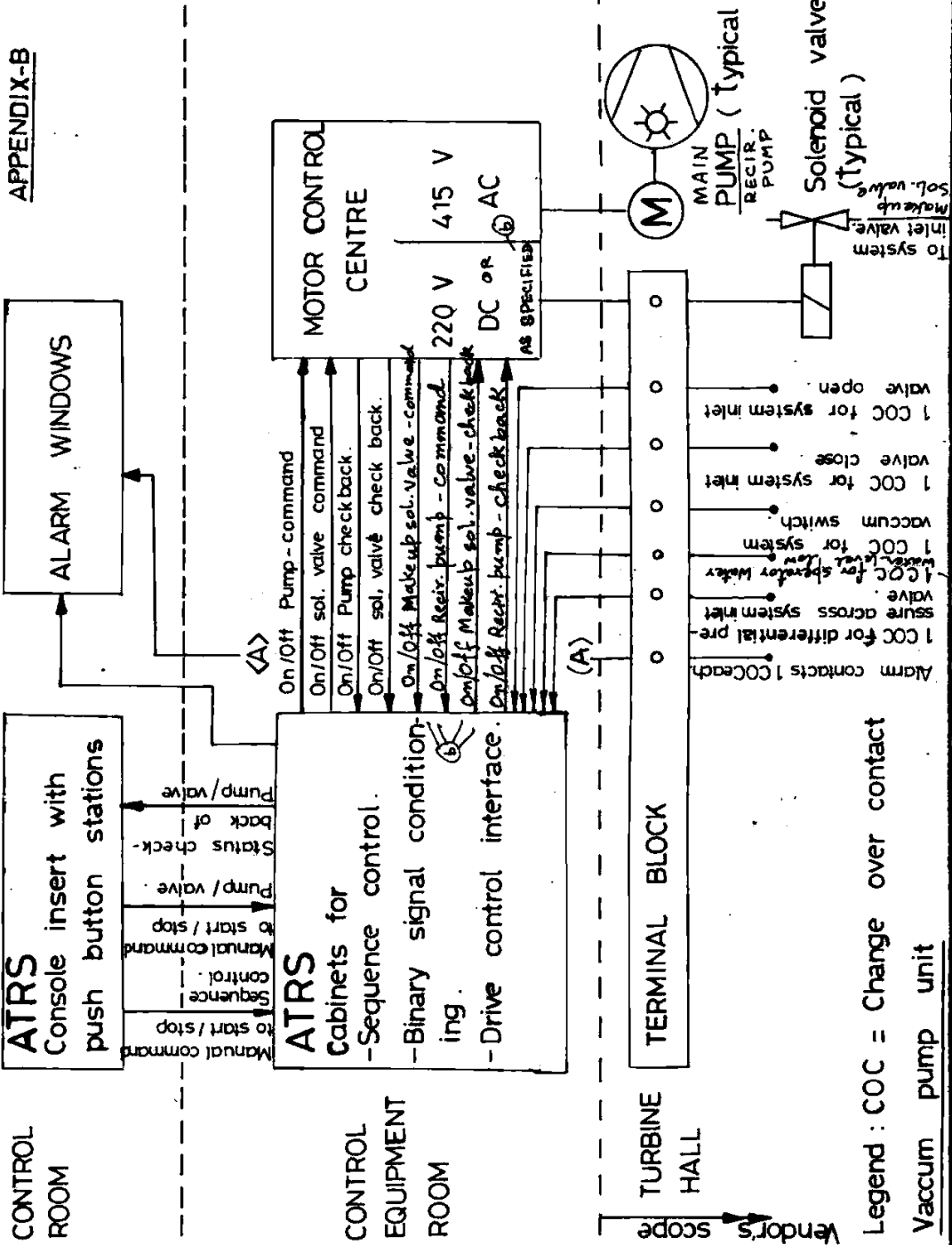

Legend : COC = Change over contact  
Vacuum pump unit

REV.	b	4	WKD. BY	N. SANYAL	7.9.93
SIGN. & DATE	<i>[Signature]</i>	15/7/93	CHD. BY	N.P. MATHUR	14-9-93



PRODUCT STANDARD  
HEAT EXCHANGER ENGINEERING

HE 57016

PAGE 14 OF 29

SIGN & DATE

SUPPLIER'S INVENTORY NO.

COPYRIGHT AND CONFIDENTIAL  
The information on this document is the property of BHARAT HEAVY ELECTRICALS LIMITED. It must not be used directly or indirectly in any way detrimental to the interest of the company.

SIGN & DATE

INVENTORY NO.

4-10-93

P-5778

APPENDIX-C

INDUCTION MOTOR

1.0 SCOPE:

This specification covers the design, manufacture, painting, inspection and testing at vendor's/subvendor's works of three phase squirrel cage induction motor. These requirements shall however be read alongwith the requirements of the respective driven equipment being supplied under the specification.

2.0 CODES AND STANDARDS:

2.1 All motors shall conform to the latest applicable standards of IS and IEC except where modified or supplemented by this specification.

2.2 Motors shall conform to the latest revisions of the following Indian Standards or equivalent IEC/VDE standards for the applicable motor type and rating.

- IS: 325 Specification for three phase induction motors.
- IS: 1231 Dimensions of three phase foot mounted induction motors
- IS: 2253 Types of construction and mounting of motors.
- IS: 3202 Code of practice for climate proofing of electrical equipment.
- IS: 4029 Guide for testing three phase induction motors.
- IS: 4691 Degree of protection provided by enclosure for electrical machines.
- IS: 4722 Specification of rotating electrical machines.
- IS: 6362 Designation of method of cooling of rotating electrical machines.
- IS: 12075 Mechanical vibration of rotating electrical m/cs...
- ~~IEC Document 2 (Central office) 432: Three phase induction motors.~~
- ~~VDE 0530 part 1/1.66 Three phase induction motors.~~

REV.	6	3			WRD. BY	N.SANYAL	<i>[Signature]</i>	7.9.93
SIGN. & DATE	<i>[Signature]</i>	<i>[Signature]</i>			CHD. BY	N.RMATHUR	<i>[Signature]</i>	14-9-93



**PRODUCT STANDARD**  
**HEAT EXCHANGER ENGINEERING**

**HE 57016**

PAGE 15 OF 29

SIGN & DATE

SUPERSEDES INVENTORY NO.

COPYRIGHT AND CONFIDENTIAL  
The information on this document is the property of BHARAT HEAVY ELECTRICALS LIMITED. It must not be used directly or indirectly in any way detrimental to the interest of the company.

SIGN & DATE

INVENTORY NO.

2.3 Other standards which ensures equal or better quality than specified may be acceptable, however differences are to be brought clearly.

2.4 The design, manufacture, installation and performance of motors shall conform to the provisions of latest Indian Electricity Act and Indian Electricity Rules. Nothing in these specifications shall be construed to relieve the contractor of this responsibility.

2.5 Degree of protection for motor should be IP54 or better.

**3.0 DRIVEN EQUIPMENT:**

*rated for continuous duty (S1) for*  
Motors shall be ~~capable of~~ giving satisfactory operation for the application and duty as required by the driven equipment at all conditions of operation.

**4.0 PERFORMANCE AND CHARACTERISTICS:**

4.1 Motors shall be capable of giving rated output without reduction in expected life span when operated continuously in the system having the following particulars.

- a) Rated voltage 415 volts (3 phase, 50 Hz).
- b) Variation in voltage  $\pm 10\%$ .
- c) Variation in frequency  $\pm 5\%$ .
- d) Combined voltage and frequency variation 10% *(sum of absolute values)*

4.2 Motors shall be suitable for full direct on line starting. These shall be capable of starting and accelerating to the rated speed alongwith the driven equipment without exceeding the acceptable winding temperature even when the supply voltage is 80% of the rated voltage, the permissible voltage specified above.

4.3 The locked rotor current shall not exceed 600% of rated full load current inclusive of tolerances.

4.4 Motors shall be designed as to be capable of withstanding the voltage and torque stresses developed due to the difference between the motor residual voltage and incoming voltage equal to 150% of rated voltage during fast change over of buses.

4.5 Motors shall be capable of developing rated full load torque even when the supply voltage drops to 70% of rated voltage. Such operation is envisaged for a period of one second. The pull out torque of the motor to meet this requirement shall not be less than 205% of full load torque.

REV.	6	3			WKD BY	N.SANYAL	<i>[Signature]</i>	7.9.93
SIGN. & DATE	<i>[Signature]</i>	15/11/93			CHD. BY	N.P.MATHUR	<i>[Signature]</i>	14-9-93

4-10-93

P-5778



PRODUCT STANDARD  
HEAT EXCHANGER ENGINEERING

HE 57016

PAGE 16 OF 29

SIGN & DATE

SUPERSEDES INVENTORY NO.

COPYRIGHT AND CONFIDENTIAL  
The information on this document is the property of BHARAT HEAVY ELECTRICALS LIMITED. It must not be used directly or indirectly in any way detrimental to the interest of the company.

SIGN & DATE

INVENTORY NO.  
P-5778

4-18-93

4.6 Motors shall be designed to withstand 120% of rated speed for two minutes without any mechanical damage in either direction of rotation.

4.7 Motors shall be capable of satisfactory operation of full load at a supply voltage of 80% of rated voltage for 5 minutes, commencing from hot condition.

4.8 The locked rotor with-stand time under hot condition at rated voltage shall be atleast 2.5 seconds more than the starting time.

4.9 Motors when started with the drive imposing its full starting torque under the specified supply voltage variations (see clause 4.1) shall be capable of withstanding atleast two starts in succession under the specified conditions of load, torque and inertia, with the motor initially at its normal running temperature windings. The motors shall also be suitable for three equally spread starts per hour under above specified supply conditions. (b)

5.0 INSULATION AND WINDINGS:

All insulated winding conductor shall be of copper. Class of insulation must be atleast class-B. The winding shall be suitable for hot, humid, tropical climate with ambient temperature of 50.0 deg C. The insulation shall be given fungicidal and tropical treatment as per IS-3202.

6.0 TEMPERATURE RISE:

The maximum permissible temperature rise over the ambient temperature of 50 deg C shall be within limits specified in IS-325 (for 3-phase induction motors) after adjustment to increased ambient temperature specified above.

7.0 CONSTRUCTIONAL FEATURES:

7.1 The motor construction shall be suitable for easy disassembly and reassembly. The enclosure shall be sturdy and shall permit easy removal of any part of the motor for inspection/repairs.

7.2 Rotor shall be properly balanced so as to keep the vibration under running condition within the limits specified in relevant standards.

REV.	6	1			WKD. BY	N. SANYAL	<i>[Signature]</i>	7-9-93
SIGN. & DATE	<i>[Signature]</i>	15/2/99			CHD. BY	N.P. MATHUR	<i>[Signature]</i>	14-9-93



**PRODUCT STANDARD**  
**HEAT EXCHANGER ENGINEERING**

**HE 57016**

PAGE 17 OF 29

SIGN & DATE

SUPERSEDES INVENTORY NO.

COPYRIGHT AND CONFIDENTIAL  
 The information on this document is the property of BHARAT HEAVY ELECTRICALS LIMITED. It must not be used directly or indirectly in any way detrimental to the interest of the company.

SIGN & DATE

INVENTORY NO.

7.3 Rotors shall be so designed as to keep the combined critical speed with the driven equipment away from the running speed by at least 20%.

7.4 Two independent earthing points shall be provided on opposite side of the motor for bolted connection for owner's earthing conductor. *Size of earthing conductor is to be specified.*

7.5 Motors shall have drain plugs so located that they will drain water resulting from condensation or other causes from all pockets in the motor casing.

7.6 Motors weighing more than 25 Kg. shall be provided with eye bolt lugs or other suitable means to facilitate lifting.

**8.0 BEARINGS:**

8.1 Greased ball and roller bearings shall be of reputed make. The minimum standard life of bearings shall not be less than 30,000 working hours taking all motor and driven loads into account. These shall be pressure grease gun lubricated type, fitted with grease nipples and shall have relief device.

8.2 Bearings and their housings shall be so constructed that loss of grease and its creeping along the shaft into motor housing is prevented. It shall also prevent dirt and water from getting into the motor.

**9.0 SPACE HEATERS:**

9.1 Space heaters shall be provided for all motors above 30 KW capacity suitable for 240 volts single phase, 50 Hz supply.

9.2 Terminals of the space heaters shall be brought out on a separate terminal box.

**10.0 TERMINAL BOX AND LEADS:**

10.1 Separate terminal box should be provided for each of the following:

- a) Stator leads.
- b) Space heaters.

REV.	6	1			WKD. BY	N.SANYAL	<i>[Signature]</i>	7.9.93
SIGN. & DATE	<i>[Signature]</i>	15/9/93			CHD. BY	N.P.MATHUR	<i>[Signature]</i>	14-9-93

4/10/93

P-5778



# PRODUCT STANDARD HEAT EXCHANGER ENGINEERING

## HE 57016

PAGE 18 OF 29

REV. & DATE

INVENTORY NO.

**COPYRIGHT AND CONFIDENTIAL**  
The information on this document is the property of BHARAT HEAVY ELECTRICALS LIMITED. It must not be used directly or indirectly in any way determined to the interest of the company.

REV. & DATE

INVENTORY NO.

10.2 Terminal boxes shall be of weather proof construction designed for outdoor service. To eliminate entry of dust and water, gaskets of neoprene or approved equivalent shall be provided at cover joints and between box and motor frame.

10.3 Terminal box shall be suitable for top and bottom entry of cables.

10.4 Unless otherwise approved, the terminal box shall be capable of being turned through 360 degrees in steps of 90 degrees.

10.5 All 415 volts terminal boxes shall be suitable for receiving 1.1 KV grade PVC insulated, PVC sheathed cables conforming to IS-1554.

10.6 Suitable tinned brass compression type cable glands and cable lugs shall be supplied by the contractor to match owner's cables.

10.7 Marking of all terminals shall be in accordance with IS-4728.

### 11.0 RATING PLATES:

11.1 Rating plates shall be provided for all motors, giving the details as called in the relevant standard e.g. IS 325 for three phase squirrel cage induction motor.

11.2 In addition to above, the rating plates shall indicate the following:

- a) Temperature rise in deg C under normal working conditions.
- b) Phase sequence corresponding to the direction of rotation for the application.
- c) Bearing identification number (in case of ball/roller bearing) and recommended lubricant.

### 12.0 TESTS:

12.1 Motors after complete assembly shall be subjected to both type and routine tests as per <sup>applicable</sup> relevant standards. ~~e.g. IS 325 and IS 4089 for 3 phase induction motors.~~ If however, the motor being supplied is a standard one, type test results carried out earlier on prototype or on any other machine of the same frame size shall be furnished alongwith the bid for BHEL's ~~review & approval~~ information.

REV.	6	2			WKD. BY	N. SANYAL	<i>[Signature]</i>	7.9.93
SIGN. & DATE	<i>[Signature]</i>	15/2/99			CHD. BY	N.P. MATHUR	<i>[Signature]</i>	14-9-93

P-5778  
4-10-85



**PRODUCT STANDARD**  
**HEAT EXCHANGER ENGINEERING**

**HE 57016**

PAGE 19 OF 29

SIGN & DATE

SUPERVISOR'S INVENTORY NO.

**COPYRIGHT AND CONFIDENTIAL**  
The information on this document is the property of BHARAT HEAVY ELECTRICALS LIMITED. It must not be used directly or indirectly in any way detrimental to the interest of the company

SIGN & DATE

4.10.93

INVENTORY NO.

P-5778

12.2 In addition, the following tests shall also be carried out.

a) Motors shall be designed to withstand 1.2 times the maximum rated speed for 2 minutes duration as specified in IS: 325.

b) Measurement of vibration shall be carried out as specified in IS: 12075.

12.3 Results of routine tests on all motors and results of type tests in accordance with the relevant standards shall be furnished in 4 copies to BHEL for its scrutiny and approval.

REV.					WKD.BY	N.SANYAL	<i>[Signature]</i>	7-9-93
SIGN. & DATE					CHD.BY	NP.MATHUR	<i>[Signature]</i>	14-9-93



PRODUCT STANDARD  
HEAT EXCHANGER ENGINEERING

HE 57016

PAGE 20 OF 29

SIGN &amp; DATE

SUPERVISOR'S  
INVENTORY NO.APPENDIX-DVACUUM PUMP : DATA SHEET

(To be filled-in &amp; submitted with the bid)

I GENERAL

- 1 Duty : Condenser air evacuation  
2 Type : Liquid Ring Type  
3 Bidder's name :  
4 Model No.:

II SCOPE OF SUPPLY

(Refer system flow diagram at Appendix-A, for identification of various parts/components)

- 1 Vacuum Pump Yes  
2 Main drive motor with space heater Yes  
3 Coupling with coupling-guard Yes  
4 Combined base plate (with foundation bolts, shims, nuts, washers etc.) Yes  
5 Air water separator Yes  
6 Water level gauge (on separator) Yes  
7 Rotameter with isolating valve Yes  
8 Check valve at separator outlet (with silencer, if required) Yes  
9 High & low level switches for alarm Yes  
10 Seal water float operated make-up <sup>solenoid</sup> valve Yes  
11 Seal water float operated overflow valve/  
or overflow drain lock Yes  
12 System inlet valve Yes  
13 Differential pressure switch Yes  
14 Vacuum switch for standby pump operation Yes  
15 Vacuum gauge with valve Yes  
16 Pressure transmitter Yes/No  
17 Air ejector system Yes/No  
18 Anti-cavitation device with control Yes  
19 Instrument air filter with regulator Yes  
20 Seal water recirculation pump with motor Yes  
21 Heat exchanger (shell & tube type) Yes  
(tube O.D. shall not be less than 5/8")  
22 Pressure gauge with valve Yes  
23 Seal water flow indicator Yes  
(for seal water flow measurement)  
24 Seal water flow switch Yes/No  
25 Seal water temperature switch Yes/No  
26 Temperature gauge with thermowell Yes  
(at all the four terminals of the heat exchanger)

COPYRIGHT AND CONFIDENTIAL

The information on this document is the property of BHARAT HEAVY ELECTRICALS LIMITED. It must not be used directly or indirectly in any way detrimental to the interest of the company.

SIGN &amp; DATE

4.10.93

INVENTORY NO.

P-5778

REV.

6

1

WKD.BY.

N.SANYAL

7.9.93

SIGN &amp; DATE

CHD. BY

N.P.MATHUR

14-9-93



**PRODUCT STANDARD**  
**HEAT EXCHANGER ENGINEERING**

**HE 57016**

PAGE 21 OF 29

SIGN & DATE

SUPERVISOR'S INVENTORY NO.

COPYRIGHT AND CONFIDENTIAL  
The information on this document is the property of BHARAT HEAVY ELECTRICALS LIMITED. It must not be used directly or indirectly in any way detrimental to the interest of the company.

SIGN & DATE

INVENTORY NO.

- 27 Terminal box Yes
- 28 Necessary valves/piping/instruments etc. (to make the system complete) Yes
- 29 Companion flanges with gaskets, fasteners etc. (for purchaser's terminal points) Yes
- 30 Items not included above (list the items)

**III DESIGN AND PERFORMANCE**

- 1 Codes and Standards :
- 2 Capacity in free dry air saturated with water vapour at suction pressure of 1" Hg absolute and subcooled by 7.5 deg F : SCFM
- 3 Capacity in free dry air saturated with water vapour at suction pressure of 0.5" Hg absolute and subcooled by 7.5 deg F : SCFM
- 4 Discharge Pressure : Atmospheric
- 5 Blank off suction pressure : mbar  
(with cooling water temperature at Condenser design point as specified in the Annexure)
- 6 Power required at motor terminals :
  - a. Maximum. kW
  - b. At Pump design point (1"Hg abs. suction pr.) kW
  - c. At Condenser design point (as specified in Annex.) kW
- 7 Cooling water required : cu.m/hr
- 8 Cooling water pressure drop : mwc  
(across heat exchanger terminals)
- 9 Sealing water flow : cu.m/hr
- 10 Sealing water pressure drop : mwc  
(across heat exchanger terminals)
- 11 Pump down time : min  
(with two pumps, c.w.temp. at Condenser design point & volume to be evacuated as specified in the Annexure)
- 12 Instrument air requirement with pressure:
- 13 Vacuum Pump
  - 13.1 No. of stages :
  - 13.2 Pump rated speed : rpm

4-10-93

P-5778

REV.					WKD. BY	N.SANYAL	<i>[Signature]</i>	7-9-93
SIGN. & DATE					CHD. BY	N.P.MATHUR	<i>[Signature]</i>	14-9-93



**PRODUCT STANDARD**  
**HEAT EXCHANGER ENGINEERING**

**HE 57016**

PAGE 22 OF 29

SIGN & DATE

SUPERSEDES INVENTORY NO.

**COPYRIGHT AND CONFIDENTIAL**  
The information on this document is the property of BHARAT HEAVY ELECTRICALS LIMITED. It must not be used directly or indirectly in any way detrimental to the interest of the company

SIGN & DATE

INVENTORY NO.

4-10-93  
P-5778

- 13.3 Rotor vane tip speed : m/sec
  - 13.4 Moment of Inertia :
    - a. Pump : kg-sq.m
    - b. Pump Motor set : kg-sq.m
  - 13.5 Pump starting torque : kg.m
  - 13.6 Pump design torque : kg.m
  
  - 14 Seal water heat exchanger
    - 14.1 Type : Shell and tube
    - 14.2 Range of c.w.inlet temp. : As indicated in Annexure
    - 14.3 Heat transfer area : sq.m

At Pump design point (1" Hg abs. suction pressure):

  - 14.4(A) Total heat load : kcal/hr
  - 14.5(A) Heat exchanger terminal-temperatures:
    - a. At Cooling water inlet (considered) : deg C
    - b. At Cooling water outlet : deg C
    - c. At Seal water inlet : deg C
    - d. At Seal water outlet : deg C
  - 14.6(A) Heat transfer rate : kcal/hr-sq.m-deg C
  

At Condenser design point-as specified in the Annexure

  - 14.4(B) Total heat load : kcal/hr
  - 14.5(B) Heat exchanger terminal-temperatures:
    - a. At Cooling water inlet (considered) : deg C
    - b. At Cooling water outlet : deg C
    - c. At Seal water inlet : deg C
    - d. At Seal water outlet : deg C
  - 14.6(B) Heat transfer rate : kcal/hr-sq.m-deg C
- 14.7 Design pressure
  - a. Shell side : kg/sq.cm g
  - b. Tube side : kg/sq.cm g
- 14.8 Test pressure
  - a. Shell side : kg/sq.cm g
  - b. Tube side : kg/sq.cm g
- 15 Seal water recirculation pump
  - 15.1 Design capacity : cubic m/hr
  - 15.2 Total Developed Head at design capacity : mwc
  - 15.3 Shut off head : mwc
  - 15.4 Power absorbed (at motor terminals) : kW
  - 15.5 Motor rating : kW

REV.					WKD.BY	N.SANYAL	<i>[Signature]</i>	7.9.93
SIGN. & DATE					CHD.BY	N.P.MATHUR	<i>[Signature]</i>	14-9-93



**PRODUCT STANDARD**  
**HEAT EXCHANGER ENGINEERING**

**HE 57016**

PAGE 23 OF 29

SIGN & DATE

SUPERSEDES INVENTORY NO.

**COPYRIGHT AND CONFIDENTIAL**  
The information on this document is the property of BHARAT HEAVY ELECTRICALS LIMITED. It must not be used directly or indirectly in any way detrimental to the interest of the company.

SIGN & DATE

INVENTORY NO.

4-10-73

P-5778

**IV Construction features and material of construction**

- 1 Vacuum Pump
  - a. Manufacturer
  - b. Model No.
  - c. No. of stages.
  - d. Rotation (when viewed from drive end)
  - e. Bearings (1st stage)  
No., type and size (each end)
  - f. Bearings (2nd stage, if applicable)  
No., type and size (each end)
  - g. Suction connection size. mm NB
  - h. Discharge connection size. mm NB
  - i. Casing material
  - j. Impeller material
  - k. Wearing sleeve material
  - l. Shaft material
  
- 2 Heat exchanger
  - a. Manufacturer
  - b. Type of tubes Straight
  - c. No. of passes on tube side.
  - d. Tube size (O/D X thickness X length) mm
  - e. Tube material
  - f. Tube plate material
  - g. Shell material
  - h. Water box (Bonnet/Channel) material
  
- 3 Seal water recirculation pump
  - a. Manufacturer
  - b. Type Centrifugal
  - c. Model
  - d. Casing material
  - e. Impeller material
  - f. Shaft material
  - g. Material of shaft sleeves (if provided)
  
- 4 Air Ejector (if provided)
  - a. Manufacturer
  - b. Suction size. mm NB
  - c. Discharge size. mm NB
  - d. Nozzle material
  - e. Diffuser material
  
- 5 Space heaters
  - a. Manufacturer
  - b. Model No.
  - c. Wattage rating
  - d. Nos. each kW
  - e. Rated Voltage and No. of phases.

REV.					WKD. BY	N.SANYAL	<i>Nf</i>	7.9.93
SIGN. & DATE					CHD. BY	N.P.MATHUR	<i>Nm and</i>	14-9-93



**PRODUCT STANDARD**  
**HEAT EXCHANGER ENGINEERING**

**HE 57016**

PAGE 24 OF 29

SIGN & DATE

SUPERSEDES INVENTORY NO.

**COPYRIGHT AND CONFIDENTIAL**

The information on this document is the property of BHARAT HEAVY ELECTRICALS LIMITED. It must not be used directly or indirectly in any way detrimental to the interest of the company.

SIGN & DATE

4-10-93

INVENTORY NO.

P-5778

- 6 Air Water Separator
  - a. Manufacturer
  - b. Size, dia. X length and volume
  - c. Material
- 7 Air flow meter (Rotameter)
  - a. Manufacturer
  - b. Type
  - c. Model no.
  - d. Range (must be atleast 1.5 times the pump capacity at 76.0 mm Hg abs. suction pressure) kg/hr
- 8 Check Valve (at separator outlet)
  - a. Manufacturer
  - b. Model No.
  - c. Size mm NB
  - d. Seat material
- 9 ~~Float operated Seal water makeup valve~~ <sup>solenoid</sup> (6)
  - a. Manufacturer
  - b. Model No.
  - c. Size mm NB
  - d. Seat material
- 10 Float operated seal water over flow valve (if provided) (6)
  - a. Manufacturer
  - b. Model No.
  - c. Size mm NB
  - d. Seat material
- 11 Duplex filter (if specified in the Annexure)
  - a. Manufacturer
  - b. Model No.
  - c. Mesh size
  - d. Valve seat material
  - e. Baskets & inserts material
  - f. Pressure drop (at design c.w. flow) mwc

**V Guaranteed Performance**

- a. Capacity in free dry air saturated with water vapour at suction pressure of 1" Hg absolute and subcooled by 7.5 deg F at design ITD. SCFM
- b. Total Power consumption at motor terminals at condenser design point (including seal water pump) kW  
Bidder is liable to pay as penalty an amount/kW (if specified in the Annexure) for extra power consumption over the guaranteed value.

REV.	6	1			WKD. BY	N. SANYAL	<i>[Signature]</i>	7-9-93
SIGN. & DATE	<i>[Signature]</i>	15/2/99			CHD. BY	N.P. MATHUR	<i>[Signature]</i>	14-9-93



**PRODUCT STANDARD**  
**HEAT EXCHANGER ENGINEERING**

**HE 57016**

PAGE 25 OF 29

SIGN & DATE

SUPERSEDES  
INVENTORY NO.

**COPYRIGHT AND CONFIDENTIAL**  
The information on this document is the property of BHARAT HEAVY ELECTRICALS LIMITED. It must not be used directly or indirectly in any way detrimental to the interest of the company.

c. Pump down time to evacuate vol. shown in the Annexure from atm. pressure to 10" Hg abs. minutes

**VI Tests and inspection**

Will all the tests, inspection and test certificates detailed in the specification be conducted/furnished ?

If no, please furnish details of non-compliance. Yes/No

**VII Weights and Spaces**

- 1 Weights.
  - a. Complete package (dry) kg
  - b. Complete package (operating) kg
  - c. Pump alone. kg
  - d. Motor alone. kg
- 2 Floor space required. mmXmm
- 3 Maintenance space required.

SIGN & DATE

4/10/93

INVENTORY NO.

P-5778

REV.					WKD. BY	N.SANYAL	<i>[Signature]</i>	7.9.93
SIGN. & DATE					CHD. BY	N.P.MATHUR	<i>[Signature]</i>	14-9-93



**PRODUCT STANDARD**  
**HEAT EXCHANGER ENGINEERING**

**HE 57016**

PAGE 26 OF 29

**APPENDIX-E**

**MOTOR: DATA SHEET**

(to be filled-in & submitted with the bid)

**1.0 GENERAL**

- i) Manufacturer. i) -----
- ii) Equipment driven by motor. ii) -----
- iii) Motor type. iii) -----
- iv) Country of origin. iv) -----

**2.0 DESIGN AND PERFORMANCE**

- i) Frame size. i) -----
- ii) Type of duty. ii) -----
- iii) Type of enclosure and method of cooling. iii) -----
- iv) Degree of protection. iv) -----
- v) Applicable standard to which motor generally conforms, v) -----
- vi) Type of mounting. vi) -----
- vii) Direction of rotation as viewed from non-driving end. vii) -----
- viii) Standard continuous rating at 40.0 deg C ambient temp. as per Indian Standard. (KW) viii) -----
- ix) Derated rating for specified ambient temp. of 50.0 deg C (KW) ix) -----
- x) Rated voltage. (Volts) x) -----
- xi) Permissible variation of \* xi) -----
  - a) Voltage. a) -----
  - b) Frequency. b) -----
  - c) Combined voltage and frequency. c) -----
- \* (Not less than asked for in the specification.)
- xii) Minimum permissible starting voltage (volts) \* xii) -----
  - \* (Not more than asked for in the specification.)
- xiii) Rated speed at rated voltage and frequency. (rpm.) xiii) -----
- xiv) Full load current. (amps.) xiv) -----
- xv) No load current. (amps.) xv) -----

SIGN & DATE

COPYRIGHT AND CONFIDENTIAL  
The information on this document is the property of BHARAT HEAVY ELECTRICALS LIMITED. It must not be used directly or indirectly in any way detrimental to the interest of the company

SIGN & DATE

INVENTORY NO.  
P-5778

REV.					WKD. BY	N. SANYAL	<i>[Signature]</i>	7.9.93
SIGN. & DATE					CHD. BY	N.P. MATHUR	<i>[Signature]</i>	14-9-93



PRODUCT STANDARD  
HEAT EXCHANGER ENGINEERING

HE 57016

PAGE 27 OF 29

SIGN & DATE

SUPERSEDES INVENTORY NO.

COPYRIGHT AND CONFIDENTIAL  
The information on this document is the property of BHARAT HEAVY ELECTRICALS LIMITED. It must not be used directly or indirectly in any way detrimental to the interest of the company.

SIGN & DATE

INVENTORY NO.

4-10-93

P-5778

- xvi) Power factor at
  - a) 100% load.
  - b) 75% load.
  - c) 50% load.
  - d) No load.
- xvii) Efficiency at rated voltage and frequency at (%)
  - a) 100% load.
  - b) 75% load.
  - c) 50% load.
- xviii) Starting current at (amps.)
  - a) 100% voltage.
  - b) 80% voltage.
- xix) Starting time with minimum permissible voltage of 80% of rated voltage.(secs.)for
  - a) Without driven equipment coupled.
  - b) With driven equipment coupled.
- xx) Starting time with 100% of rated voltage.(secs.)for
  - a) Without driven equipment coupled.
  - b) With driven equipment coupled.
- xxi) Safe stall time with 110% of rated voltage. (secs.) for
  - a) From hot condition.
  - b) From cold condition.
- xxii) Safe stall time with 100% of rated voltage. (secs.) for
  - a) From hot condition.
  - b) From cold condition.
- xxiii) Torque (Kg.Metre) at
  - a) Starting (at minimum permissible voltage)
  - b) Pull up.
  - c) Pull out.
  - d) Rated load.
- xxiv) Stator winding resistance per phase. (ohms).
- xxv) Fly wheel moment of inertia (GDsquare) of motor(Kg-sq.m)
- xxvi) Size of earthing conductor

- xvi)
  - a) -----
  - b) -----
  - c) -----
  - d) -----
- xvii)
  - a) -----
  - b) -----
  - c) -----
- xviii)
  - a) -----
  - b) -----
- xix)
  - a) -----
  - b) -----
- xx)
  - a) -----
  - b) -----
- xxi)
  - a) -----
  - b) -----
- xxii)
  - a) -----
  - b) -----
- xxiii)
  - a) -----
  - b) -----
  - c) -----
  - d) -----
- xxiv) -----
- xxv) -----
- xxvi) -----

REV.	6	1			WKD. BY	N.SANYAL		7.9.93
SIGN. & DATE		15/11/93			CHD. BY	N.P.MATUR		14-9-93



PRODUCT STANDARD  
HEAT EXCHANGER ENGINEERING

HE 57016

PAGE 28 OF 29

SIGN & DATE

SUPERSEDES INVENTORY NO.

COPYRIGHT AND CONFIDENTIAL

The information on this document is the property of BHARAT HEAVY ELECTRICALS LIMITED. It must not be used directly or indirectly in any way detrimental to the interest of the company.

SIGN & DATE

4.10.93

INVENTORY NO.

P-5778

3.0 CONSTRUCTIONAL FEATURES

- i) Stator winding insulation.
  - a) Tropicalised (Yes/No). i) -----
  - b) Class & Type. a) -----
  - c) Temperature rise over 50.0 deg C ambient temp. (deg C) b) -----
  - d) Stator winding connections. c) -----
  - e) Number of terminals brought out. d) -----
- ii) Type of terminal box for
  - a) Stator leads. e) -----
  - b) Space heater. ii) -----
- iii) For main terminal box (suggestive).
  - a) Location. iii) -----
  - b) Entry of cables. a) -----
  - c) Recommended cable size. b) -----
  - d) Fault level. (MVA) KA/sec. c) -----
  - iv) Drive end/Non-Drive end. d) 50 -----
- iv) For Bearings.
  - a) Type. iv) -----
  - b) Manufacturer. a) -----
  - c) Size. b) -----
  - d) Recommended lubricant. c) -----
- v) Space heaters.
  - a) Numbers. v) -----
  - b) Location. a) -----
  - c) Power requirement. (KW) b) -----
- vi) Weight (Kg.) of
  - a) Motor stator. c) -----
  - b) Motor rotor. vi) -----
  - c) Total motor. a) -----

4.0 CHARACTERISTIC CURVES (AT 80%, 100% & 110% OF RATED VOLTAGE)

- i) Current v/s speed. Curve No. i) -----
- ii) Torque v/s speed. ii) -----
- iii) Thermal withstand curve. iii) -----
- iv) Current v/s time. iv) -----

REV.	b	1			WKD. BY	N. SANYAL	<i>[Signature]</i>	7.9.93
SIGN. & DATE	<i>[Signature]</i>	15/2/93			CHD. BY	N. R. MATHUR	<i>[Signature]</i>	14-9-93

