

DRAWING NO. 3-V-0000-23992

6.3 / 3.2 / 1.6

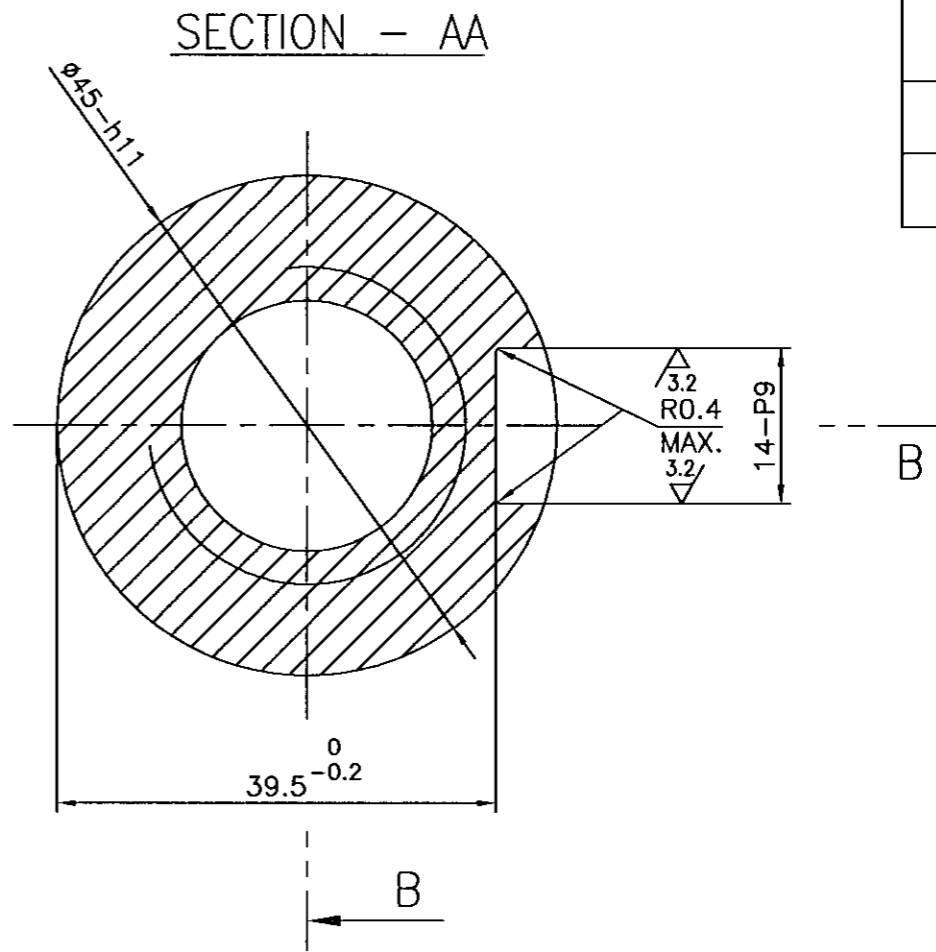
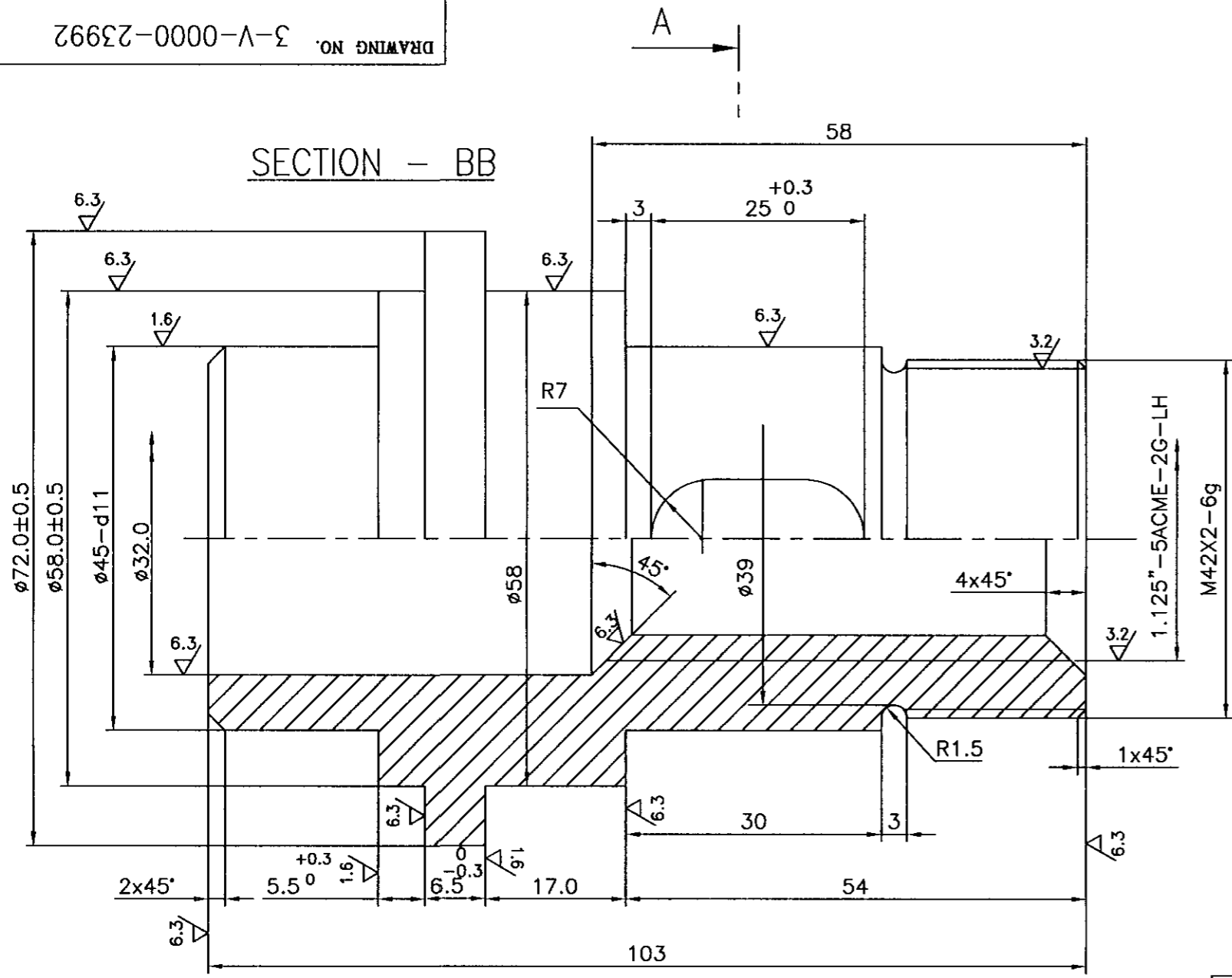

Ø45-d11	-0.080 -0.240
Ø45-h11	-0.160 0
14-P9	-0.018 -0.061

NOTE:

01. BREAK ALL SHARP CORNERS.

NO OFF	DESCRIPTION	MATL CODE	MATL SPECN	HEAT TREATMENT	SCRAP SORT	NET WT (kg)	GROSS WT (kg)	DRAWING No	ITEM No
02	SUGG.MIN.SIZE DIA 75 X 115	16 024 039	IS305 GR.AB1 CERTIFY	-	60	1.02	3.99	3.V.U184.23992 931108230000	-
01	CASTING	92 201 426	DUCTILE IRON CERTIFY	-	10	1.02	2.20	3.V.NC06.23992 931107850000	-

CAUTION: The information on this document is the property of BHARAT HEAVY ELECTRICALS LTD. It must not be used directly or indirectly in any way detrimental to the interest of the company.

TYPE OF PRODUCT OR NAME OF CUSTOMER/PROJECT									
BHARAT HEAVY ELECTRICALS LTD., UNIT: HIGH PRESSURE BOILER PLANT. TIRUCHIRAPALLI-620014.					DRN	NAME	SIGN	DATE	NO.OF VAR.
					CHD	P.Boomnathan		05.04.03	
					APPD	K.S.Raman		05.04.03	
DEPT	VL	SCALE	WEIGHT (KG)	REFERENCE INFORMATION			NO. OF ITEMS		
320		NTS	1.07	CAD :C323992					
TITLE					CARD CODE	DRAWING NO.			REV
YOKE BUSH					U 01	3-V-0000-23992			

REV	DATE	ALTERED
		CHD & APPD

96627-0000-V-3
DRAWING NO.

12.5 / 6.3 / 3.2

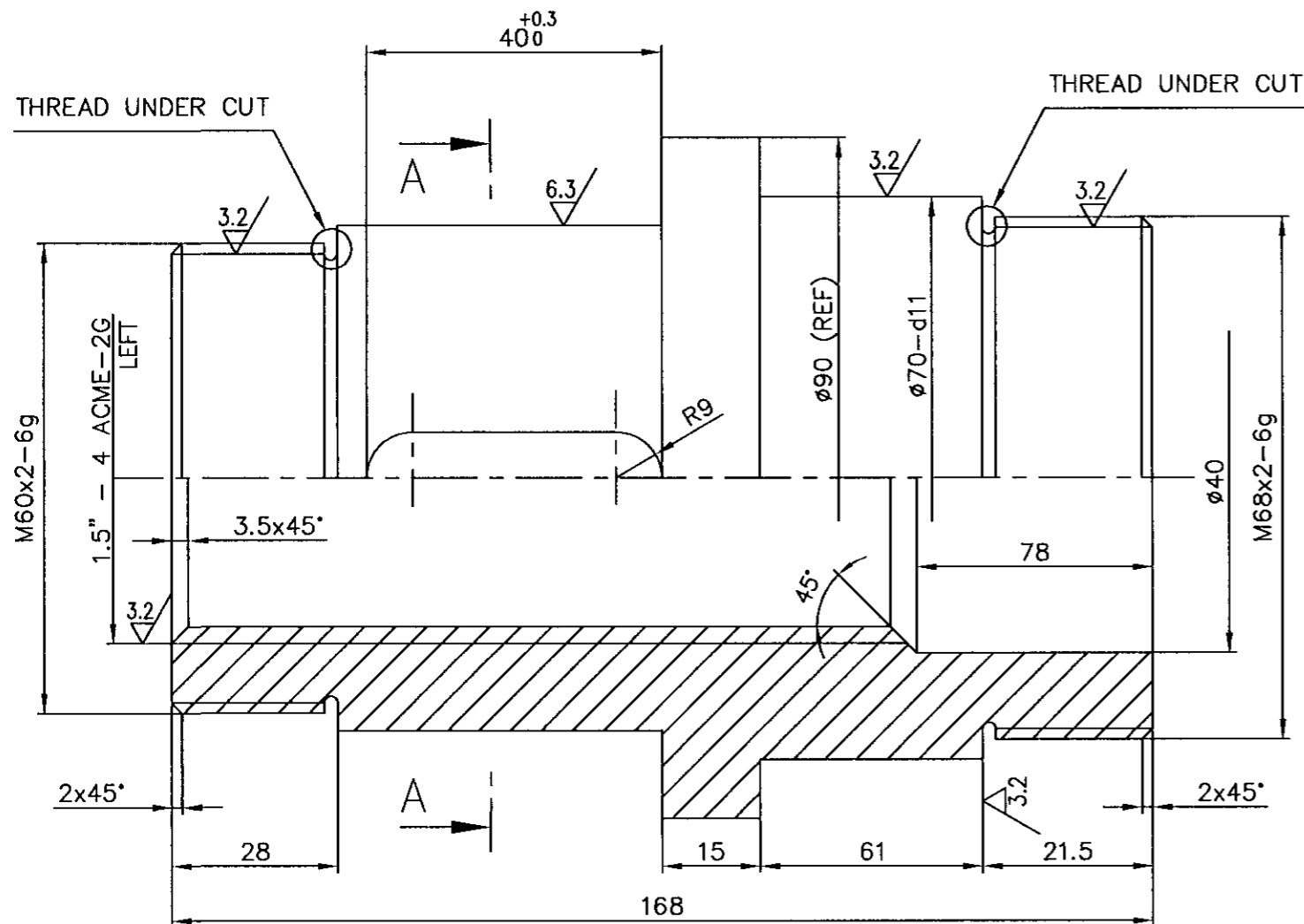

SECTION-AA

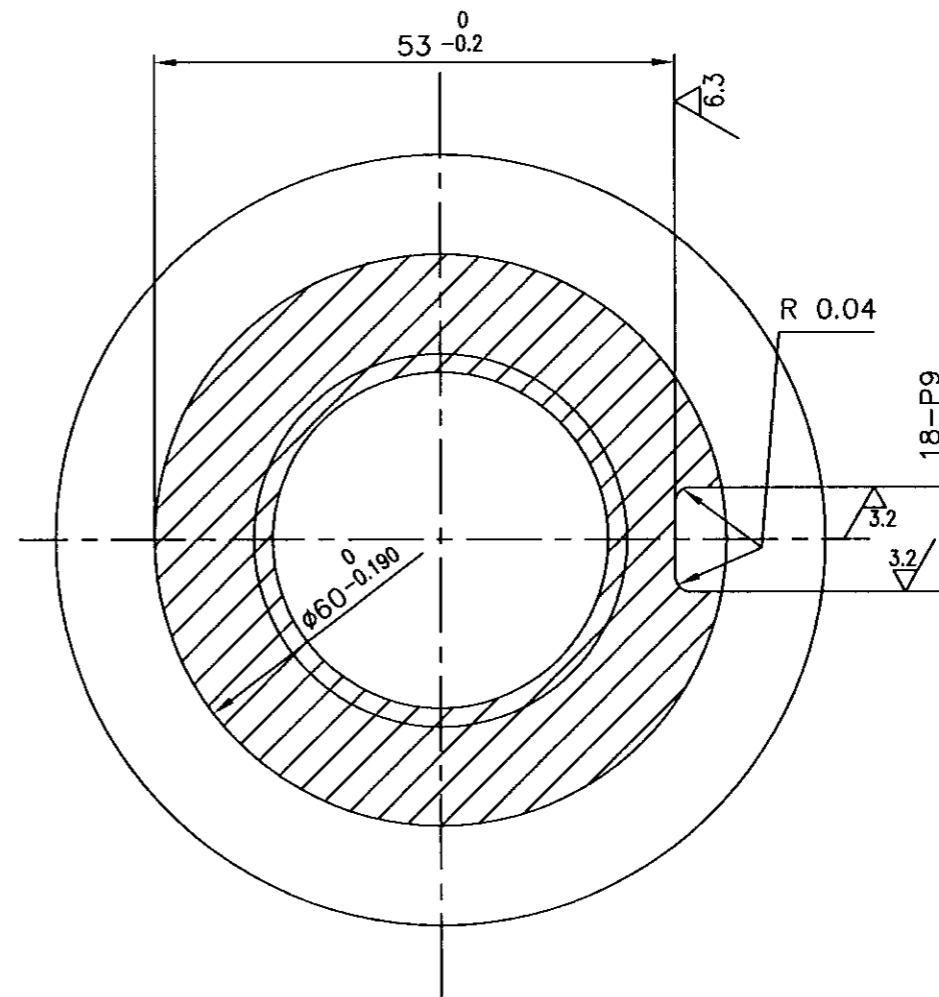

Ø70-d11	-0.100
	-0.290
18-P9	-0.018
	-0.061

02	Ø90x28x180	16 024 025	IS 305 Gr.AB1 CERTIFY	--	60	4.1	8.1	3.V.U185.23996 931108210000	--
01	CASTING	92 201 432	S.G.IRON CERTIFY	--	10	4.1	4.8	3.V.NC12.23996 931108010000	--
SL No.	DESCRIPTION	MATL CODE	MATL SPECN	HEAT TREATMENT	SCRAP SORT	NET WT (kg)	GROSS WT (kg)	DRAWING No COMPONENT CODE	ITEM No

CAUTION: The information on this document is the property of BHARAT HEAVY ELECTRICALS LTD. It must not be used directly or indirectly in any way detrimental to the interest of the company.

TYPE OF PRODUCT OR NAME OF CUSTOMER/PROJECT		CS	
DEPT VL CODE 320		BHARAT HEAVY ELECTRICALS LTD. UNIT: HIGH PRESSURE BOILER PLANT. TIRUCHIRAPALLI 620014.	
SCALE NTS		WEIGHT (KG) 4.1	
TITLE YOKE BUSH		REFERENCE INFORMATION CAD : C323996	
CARD CODE U 01		DRAWING NO. 3-V-0000-23996	
NO. OF VAR.		NO. OF ITEMS	
REV		REV	

REV	DATE	ALTERED
		CHD & APPD

DRAWING NO. 3-V-0000-24009/1

SL. No.	DRAWING No.	COMP. CODE	MATL. CODE	MATL. SPECN	DIMENSIONS																	DIA INCH N ACME-2G LEFT	NET WT. (Kg.)	REMARKS
					∅d	∅D	∅D1	∅D2	H	W	R	L	L1	L2	L3	L4	L5	L6	L7	L8	MDxP			
01	3-V-NC08-24009	931108160000	922014370000	SG IRON, NR, CERTIFY	34	60	85	65	53	18	9	120	56	64	15	38	41	26	35	2.5	M60x2	1.25"-4 ACME	2.4	8"/150 CL.
02	3-V-NC10-24009	931300460000	922014780000		37	60	85	65	53	18	9	130	60	70	15	48	41	26	35	2.5	M60x2	1.375"-4 ACME	2.8	10"/150 CL.

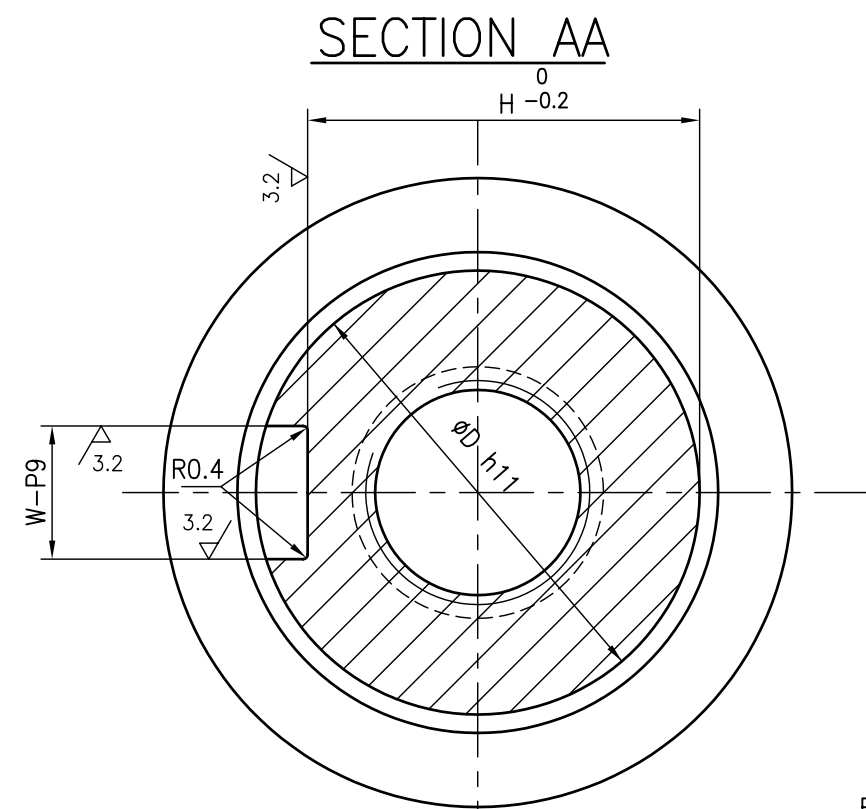
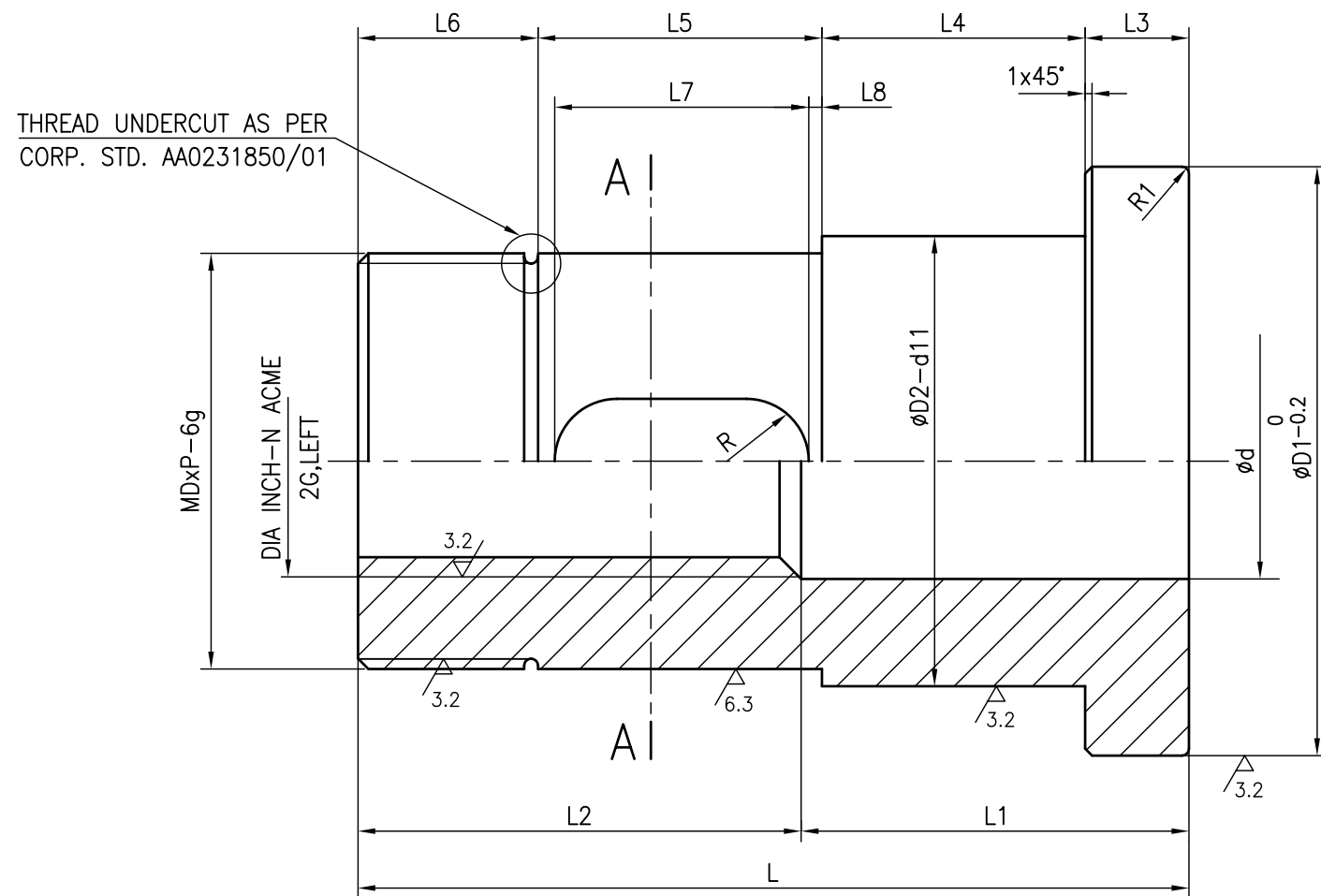

∅60-h11	0
	-0.190
18-P9	-0.018
	-0.061
∅65-d11	-0.100
	-0.290

NO OFF	DESCRIPTION	MATL CODE	MATL SPECN	HEAT TREATMENT	SCRAP SORT	NET WT (kg)	GROSS WT (kg)	DRAWING No	ITEM No

REV	DATE	ALTERED VB
1	03.11.03	CHD & APPD MRK

SL. No.02 INCLUDED.

CAUTION: The information on this document is the property of BHARAT HEAVY ELECTRICALS LTD. It must not be used directly or indirectly in any way detrimental to the interest of the company.

TYPE OF PRODUCT OR NAME OF CUSTOMER/PROJECT

BHARAT HEAVY ELECTRICALS LTD.,
 UNIT: HIGH PRESSURE BOILER PLANT.
 TIRUCHIRAPALLI-620014.

DRN	V.BAIRAVAN	SIGN	DATE	NO.OF VAR.
CHD	R.L.NARAYANAN		03.11.03	
APPD	M.RAJAKUMAR		03.11.03	

DEPT	VL	SCALE	WEIGHT (KG).	REFERENCE INFORMATION	NO. OF ITEMS
CODE	320	N T S		CAD REF: C324009	

TITLE YOKE BUSH

CARD CODE	DRAWING NO.	REV
U 01	3-V-0000-24009	1

Price Bid Annexure to Enquiry No.1415-114 Dated 13.11.2014, Due date 04.12.2014

Enq Sl. No.	Code	Description of material	Drg No	Qty (Nos)	Unit Basic Price, Rs. per No. (In figures)	Unit Basic Price, Rs. per No. (In Words)
1	931107850000P	MACHINED YOKE BUSH-NC06 (SG IRON)	3VNC0623992/00	150		
2	931108010000P	MACHINED YOKE BUSH-NC12 (SG IRON)	3VNC1223996/00	150		
3	931108160000P	MACHINED YOKE BUSH-NC08 (SG IRON)	3VNC0824009/00	320		
4	931300460000P	MACHINED YOKE BUSH-NC10 (SG IRON)	3VNC1024009/00	200		

Authorised signatory with seal

Techno-Commercial Bid Annexure to Enquiry No.1415-114 Dated 13.11.2014, Due date 04.12.2014

Enq Sl. No.	Code	Description of material	Drg No	Qty (Nos)	Unit Basic Price, Rs. per No.
1	931107850000P	MACHINED YOKE BUSH-NC06 (SG IRON)	3VNC0623992/00	150.00	Please see price bid
2	931108010000P	MACHINED YOKE BUSH-NC12 (SG IRON)	3VNC1223996/00	150.00	Please see price bid
3	931108160000P	MACHINED YOKE BUSH-NC08 (SG IRON)	3VNC0824009/00	320.00	Please see price bid
4	931300460000P	MACHINED YOKE BUSH-NC10 (SG IRON)	3VNC1024009/00	200.00	Please see price bid

Excise Duty rate (mention in % if applicable, mention as **NIL** if not applicable)

Cess on ED rate (mention in % if applicable)

CST (%) / VAT (%)

Validity of offers (**As per BHEL terms 60 days validity is required**)

The above prices are **Firm, without any price escalation; are Rs. per piece; and are on FOR Goindwal Sahib basis.**

We accept all terms and conditions of the Enquiry No.1415-114 Dated 13.11.2014, Due date 04.12.2014

Authorised signatory with seal

Certificate by Chartered Accountant on letter head

This is to Cert'fy that M/S,
(hereinafter referred to as 'company') having its registered office at
..... is registered under MSMED Act 2006, (Entrepreneur
Memorandum No (Part-11) dtd:.....,
Category:..... (Micro/Small)). (Copy enclosed).

Further verified from the Books of Accounts that the investment of the company as per the
latest audited financial year as per MSMED Act 2006 is as follows:

1. **For Manufacturing Enterprises:** Investment in plant and machinery (i.e. original cost
excluding land and building and the items specified by the Ministry of Small Scale Industries vide its
notification No.S.O.1722(E) dated October 5, 2006 :
Rs.....Lacs
2. **For Service Enterprises:** Investment in equipment (original cost excluding land and building and
furniture, fittings and other items not directly related to the service rendered or as may be notified under the MSMED
Act, 2006:
Rs.....Lacs

(Strike off whichever is not applicable)

The above investment of Rs.....Lacs is within permissible limit of
Rs.....Lacs forMicro / Small (Strike off which is not applicable)
Category under MSMED Act 2006.

Or

The company has been graduated from its original category {Micro/ Small} (Strike off which is not
applicable) and the date of graduation of such enterprise from its original category is
(dd/mm/yyyy) which is within the period of 3 years from the date of graduation of such
enterprise from its original category as notified vide S.O. No. 3322(E) dated 01.11.2013 published
in the gazette notification dated 04.11.2013 by Ministry of MSME.

Date:

(Signature)

Name-

Membership number-

Seal of Chartered Accountant