



**Bharat Heavy Electricals Limited  
Piping Centre Chennai-17**

Specification Number	Rev.no.	Sheet Number
PC:TSP:APRDS:BARH	00	1 of 27

**TECHNICAL SPECIFICATION FOR AUX.PRDS CONTROL VALVES**

**NTPC-BARH STPP (3X660 MW)**

**CONTENTS**

1.0	IMPORTANT NOTE TO THE BIDDER
2.0	SECTION I INTENT OF SPECIFICATION
3.0	SECTION II SCOPE OF WORK AND SUPPLY
4.0	SECTION III EQUIPMENT SPECIFICATION
5.0	SECTION IV GENERAL TECHNICAL REQUIREMENTS
6.0	SECTION V SPARES & SPECIAL TOOLS
7.0	TABLE V-A LIST OF SPARES
8.0	TABLE V-B LIST OF SPECIAL TOOLS
9.0	TABLE V-C LIST OF MANDATORY SPARES
10.0	SECTION VI QUALITY ASSURANCE, INSPECTION & TESTING
11.0	SECTION VII DOCUMENTS TO BE SUBMITTED ALONG WITH OFFER
12.0	SECTION VIII DOCUMENTS TO BE SUBMITTED AFTER AWARD OF CONTRACT
13.0	ANNEXURE-D APPLICABLE QUALITY PLAN

00	29.05.2015	Fresh Issue	SD/-	SD/-	SD/-
			S.KAVITA	R PRABHA	SARAVANAN C
Rev	Date	Alteration	Prepared	Approved(C&I)	Approved (Mech.)



**Bharat Heavy Electricals Limited  
Piping Centre Chennai-17**

Specification Number	Rev.no.	Sheet Number
PC:TSP:APRDS:BARH	00	2 of 27

**TECHNICAL SPECIFICATION FOR AUX.PRDS CONTROL VALVES**

Important note to the Bidder

Bidder is to take Photostat copy of Table V-A & Table V-B, control valve data sheets, Section VII and section VIII of this specification, fill it by neatly typing and submit the same along with the offer. Non-compliance of the above shall lead to rejection of the offer. Information called for in the above tables, sections of the Technical specification furnished in any other format shall be considered only for information.





**Bharat Heavy Electricals Limited  
Piping Centre Chennai-17**

Specification Number	Rev.no.	Sheet Number
PC:TSP:APRDS:BARH	00	3 of 27

**TECHNICAL SPECIFICATION FOR AUX.PRDS CONTROL VALVES**

**SECTION - I**  
**INTENT OF SPECIFICATION**

- 1.0 This specification is intended to cover the design, engineering, manufacture, shop Fabrication, assembly, tests and inspection at manufacturer's works, packing and despatch of control valves for the mentioned project.
- 2.0 The equipment to be supplied as per this Technical specification shall be suitable for the site conditions specified in Equipment specification (Section III)
- 3.0 It is not the intent to completely specify herein all aspects of design and construction of equipment. Nevertheless the equipment shall conform to all aspects of high standards of engineering , design and workmanship and shall be capable of performing in continuous commercial operation in a manner acceptable to the purchaser who will interpret the meaning of the specification, drawings and shall have right to accept or reject any work or material which in his assessment is not complete to meet the requirements of this specification and/or applicable national and/or international standards mentioned elsewhere in the specification.
- 4.0 If any provision of this specification departs from the bidder's usual construction sufficiently to materially increase cost of equipment without (in bidders opinion) providing a corresponding increase in quality or if the bidder considers that his usual construction would provide better quality, the Bidder shall call this to the attention of the Purchaser by submitting an alternate bid. However in any case, a base bid shall be submitted based on the equipment and services as specified.



**Bharat Heavy Electricals Limited  
Piping Centre Chennai-17**

Specification Number	Rev.no.	Sheet Number
PC:TSP:APRDS:BARH	00	4 of 27

**TECHNICAL SPECIFICATION FOR AUX.PRDS CONTROL VALVES**

**SECTION - II**

**SCOPE OF WORK AND SUPPLY**

**1.0 SCOPE OF WORK**

The scope of work of this specification shall include design, manufacture and delivery of control valves as detailed in various sections of this specification.

**2.0 SCOPE OF SUPPLY**

<b><u>S.No</u></b>	<b><u>Service</u></b>	<b><u>Tag name</u></b>
1	MS to Aux. steam system(HC PRV)	LBG11 AA001
2	CRH to Aux. steam system(LC PRV)	LBG12 AA001
3	CEP Spray to APRDS valves	LCE11 AA001, LCE11 AA002, LCE11 AA003, LCE11 AA004
4	HC PRV D/s. Desuperheater	LBG11 AC001
5	LT header Desuperheater	LBG11 AC002

Complete accessories such as pneumatic diaphragm actuators, smart positioners, air lock valve, limit switches, air-set (air filter with regulators and gauges), solenoid valves, junction box and hand wheel for all control valves. All accessories shall be mounted integrally, tubed and supplied.



**Bharat Heavy Electricals Limited**  
**Piping Centre Chennai-17**

Specification Number	Rev.no.	Sheet Number
PC:TSP:APRDS:BARH	00	5 of 27

**TECHNICAL SPECIFICATION FOR AUX.PRDS CONTROL VALVES**

**SECTION - III**

**EQUIPMENT SPECIFICATION**

<b><u>S.No</u></b>	<b><u>Service</u></b>	<b><u>Datasheet No.</u></b>
1	MS to Aux. steam system (HC PRV)	4-00-306-40721 (3 SHEETS)
2	CRH to Aux. steam system (LC PRV)	4-00-306-40724 (3 SHEETS)
3	CEP Spray to APRDS valves	4-00-306-40727 ((3 SHEETS), 4-00-306-40728(3 SHEETS)
4	HC PRV D/s. Desuperheater	4-00-306-40722 (1 SHEET)
5	LT header Desuperheater	4-00-306-40725 (1 SHEET)
6	Schematic Arrangement of Aux. PRDS station	4-00-306-40729 (1 SHEET)



**Bharat Heavy Electricals Limited  
Piping Centre Chennai-17**

Specification Number	Rev.no.	Sheet Number
PC:TSP:APRDS:BARH	00	6 of 27

**TECHNICAL SPECIFICATION FOR AUX.PRDS CONTROL VALVES**

**Section IV**

**General Technical Requirements**

- 1.0 The Control valves and accessories furnished by the bidder shall be designed, constructed and tested in accordance with the latest applicable requirements of code for power piping ASME B31.1, the ASME Boiler & Pressure vessel code, Indian Boiler Regulation (IBR), ISA, and other standards specified elsewhere as well as in accordance with all applicable requirements of the "Federal Occupational Safety and Health Standards, USA" or acceptable equal standards. All the control valves, their actuators and accessories with the modulating loops covered under the specification.
- 2.0 The design of all valve bodies shall meet the specification requirements and shall conform to the requirements of ANSI(USA) for dimensions, material thickness and material specification for their respective pressure classes. The general technical requirements shall conform to "NTPC technical specification – Part-B, Sub-section IV-18, Clause 1.00.00 to 8.05.00, Page No. 1 of 6 to Page No. 6 of 6.
- 3.0 The valve sizing shall be suitable for obtaining maximum flow conditions with valve openings at approximately 80% of total valve stem travel and minimum flow conditions with valve stem travel not less than 10% of total valve stem travel. All the valves shall be capable of handling at least 120% of the required maximum flow. Further the valve stem travel range from minimum flow condition to maximum flow condition shall not be less than 50% of total valve stem travel. The sizing shall be in accordance with the latest edition of ISA handbook on control valves. While deciding the size of valves, Bidder shall ensure that velocity at valve outlet does not exceed 8 m/sec for liquid service, 150 m/sec for steam services and 50% of sonic velocity for flashing services. Bidder shall furnish the sizing calculations clearly indicating the outlet velocity achieved with the valve size selected by him as well as noise calculations, which will be subject to Owner's approval during detailed engineering.



**Bharat Heavy Electricals Limited  
Piping Centre Chennai-17**

Specification Number	Rev.no.	Sheet Number
PC:TSP:APRDS:BARH	00	7 of 27

**TECHNICAL SPECIFICATION FOR AUX.PRDS CONTROL VALVES**

- 4.0 Control valves for steam and water applications shall be designed to prevent cavitation, wire drawing, flashing on the downstream side of valve and downstream piping. Thus for cavitation / flashing service, only valve with anti cavitation trim shall be provided. Detailed calculations to establish whether cavitation will occur or not for any given application shall be furnished.
- 5.0 Control valves for spray water application shall have leakage rate as per leakage class V. All other control valves shall have leakage rate as per leakage class IV
- 6.0 The control valve induced noise shall be limited to 85 dba at 1.0 meter from the valve surface under actual operating conditions. The noise abatement shall be achieved by valve body and trim design and not by use of silencers.
- 7.0 The characteristic of control valves shall be determined based on the application / service.
- 8.0 **Valve construction:**
  - 8.1 All valves shall be of globe body design & straightway pattern with single or double port, unless otherwise specified or recommended by the manufacturer to be of angle body type. Rotary valve may alternatively be offered when pressure and temp. drops permit.
  - 8.2 Valves with high lift cage-guided plugs & quick-change trims shall be supplied.
  - 8.3 Cast Iron valves are not acceptable.



**Bharat Heavy Electricals Limited**  
**Piping Centre Chennai-17**

Specification Number	Rev.no.	Sheet Number
PC:TSP:APRDS:BARH	00	8 of 27

**TECHNICAL SPECIFICATION FOR AUX.PRDS CONTROL VALVES**

- 8.4 Bonnet joints for all control valves shall be of flanged and bolted type or other construction acceptable to the owner. Bonnet joints of internal threaded or union type are not acceptable.
- 8.5 Plug shall be of one-piece construction either cast, forged or machined from solid bar stock. Plug shall be screwed and pinned to valve stems or shall be integral with the valve stems.
- 8.6 All valves connected to vacuum on down stream side shall be provided with packing suitable for vacuum application (e.g Double Vee type chevron packing)
- 8.7 Valve characteristic shall match with the process characteristics.
- 8.8 Extension Bonnets shall be provided when the maximum temperature of following fluid is greater than 280° C
- 8.9 Flanged valves shall be rated at no less than ANSI pressure class of 300 lbs.
- 9.0 **Valve Actuators:**
- 9.1 All control valves shall be furnished with pneumatic actuators. The Bidder shall be responsible for proper selection and sizing of valve actuators in accordance with the pressure drop and maximum shut off pressure and leakage class requirements. The valve actuators shall be capable of operating at 60° C continuously.
- 9.2 Valve actuators and stems shall be adequate to handle the unbalanced forces occurring under the specified flow conditions or the maximum differential pressure specified. An adequate allowance for stem force, at least 0.15 Kg/cm<sup>2</sup> per linear millimetre of seating surface, shall be provided in the selection of actuator to ensure tight seating unless otherwise specified.
- 9.3 The travel time for the actuators shall not exceed 10 seconds.



**Bharat Heavy Electricals Limited  
Piping Centre Chennai-17**

Specification Number	Rev.no.	Sheet Number
PC:TSP:APRDS:BARH	00	9 of 27

**TECHNICAL SPECIFICATION FOR AUX.PRDS CONTROL VALVES**

**10.0 Control valve Accessory Devices:**

10.1 All control valve accessories such air locks, hand wheels / hand-jacks, Torque switches, smart positioners, solenoid valves, diffusers, external volume chambers, tubing and air sets and junction boxes etc. Shall be provided as per requirements.

**11.0 NAME PLATE:**

11.1 Name plate shall be of engraved chromium plate or label with engraving filled with enamel. Nameplate data shall be inscribed on the plate in such a manner that it cannot erode or peel off. Name Plate inscriptions shall be bilingual in Hindi followed by English. Alternatively two separate plates one with Hindi and other with English inscriptions may be provided.

11.2 Name plate shall be marked in accordance with MSS standard SP-25 and ASME B16.34 as a minimum.

11.3 Valves shall be identified by owner's tag no. on a metal tag permanently attached to a non-pressure part, such as the yoke by a stainless steel wire.

11.4 All exposed steel surfaces are to be painted before despatch as per technical requirements.



**Bharat Heavy Electricals Limited  
Piping Centre Chennai-17**

Specification Number	Rev.no.	Sheet Number
PC:TSP:APRDS:BARH	00	10 of 27

**TECHNICAL SPECIFICATION FOR AUX.PRDS CONTROL VALVES**

**Section V  
Spares & Special Tools**

1.0 Commissioning spares

Commissioning spares are those spares, which may be required during start up, and commissioning of the unit. Bidder must quote for these spares and unit prices to be indicated.

2.0 Recommended spares

Recommended spares for all the items for three-year operation. Bidder must quote unit prices. Bidder shall indicate the shelf life for gaskets, packing etc. The recommended spares list shall be independent of the list of mandatory spares. The purchaser reserves the right to buy any or all of the recommended spare parts.

3.0 Mandatory spares

Mandatory spares are those spares, which are considered essential by the purchaser for Normal operation of the plant. If such spares are indicated, bidder shall indicate the Price for each and every item in the schedule of mandatory spares whether or not the Bidder considers it necessary for the purchaser to have it. If the bidder fails to comply with the above or fails to quote the price of any mandatory spares the cost of such Spares shall be deemed to be included in the contract price.



**Bharat Heavy Electricals Limited**  
**Piping Centre Chennai-17**

Specification Number	Rev.no.	Sheet Number
PC:TSP:APRDS:BARH	00	11 of 27

**TECHNICAL SPECIFICATION FOR AUX.PRDS CONTROL VALVES**

- 4.0 Bidder shall quote separately the special tools if any required for erection, commissioning and maintenance of the equipment if the bidder considers it as essential whether or not the requirement of such tools are indicated in this specification. However, if the requirements of such tools are indicated, bidder shall indicate the price for each and every item of the special tools indicated. If the bidder fails to comply with the above or fails to quote the price of special tools indicated, the cost of such special tools shall be deemed to be included in the contract price. All tools shall be new and unused.
- 5.0 Bidder shall identify the Commissioning spares, Recommended spares and Mandatory Spares in the cross sectional drawing or in the catalogue for easy reference.
- 6.0 All spares supplied under this contract shall be strictly interchangeable with the parts for which they are intended for replacements. The spares shall be treated and packed for long storage under the climatic conditions prevailing at the site. eg. Small Items shall be packed in sealed transparent plastic bags with dissector packs as necessary.
- 7.0 Each spare shall be clearly marked or labelled on the outside of the packing with its description. When more than one spare part is packed in a single case a general description of the contents shall be indicated on the outside of such cases and a detailed list enclosed. All cases, containers and other package must be suitably marked and numbered for the purpose of identification.
- 8.0 All spare parts furnished shall be new and unused. The contractor shall guarantee that in the event of any of the spares offered goes out of production notice shall be given to



**Bharat Heavy Electricals Limited  
Piping Centre Chennai-17**

Specification Number	Rev.no.	Sheet Number
PC:TSP:APRDS:BARH	00	12 of 27

**TECHNICAL SPECIFICATION FOR AUX.PRDS CONTROL VALVES**

the owner sufficiently in advance to enable him to order this requirement of spares in one lot, if he so desires.

9.0 Bidder shall indicate the service expectancy period for the spare parts under normal operating conditions before the replacement is necessary.

10.0 Complete manufacturing drawings of items shall be given to the owner as and when any spare parts is discontinued from manufacturing.

11.0 Bidder shall furnish the list of spare and special tools required as per the Table V-A and V-B.

12.0 Requirement of Mandatory Spares are indicated in Table V-C.

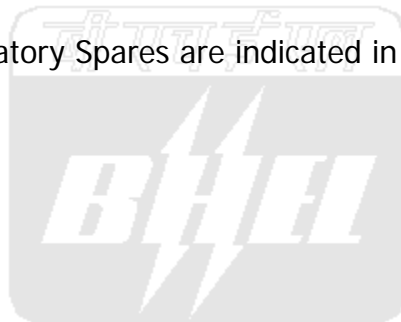



**Bharat Heavy Electricals Limited**  
**Piping Centre Chennai-17**

Specification Number	Rev.no.	Sheet Number
PC:TSP:APRDS:BARH	00	13 of 27

**TECHNICAL SPECIFICATION FOR AUX.PRDS CONTROL VALVES**

**TABLE V-A**

LIST OF SPARES  
(To be filled in by the bidder)

Sl. no	Description of spare	Reference Drawing.	Item no.	Qty. reqd For commissioning Spare.	Qty. reqd For Recommended Spare.	Qty. reqd For mandatory Spare.	COST / No

Signature of the bidder.



**Bharat Heavy Electricals Limited**  
**Piping Centre Chennai-17**

Specification Number	Rev.no.	Sheet Number
PC:TSP:APRDS:BARH	00	14 of 27

**TECHNICAL SPECIFICATION FOR AUX.PRDS CONTROL VALVES**

**TABLE V-B**

LIST OF special tools  
(To be filled in by the bidder)

Sl. no	Description of the tool	Reference Drawing.	Item no.	Quantity	COST / No

Signature of the bidder.



**Bharat Heavy Electricals Limited  
Piping Centre Chennai-17**

Specification Number	Rev.no.	Sheet Number
PC:TSP:APRDS:BARH	00	15 of 27

**TECHNICAL SPECIFICATION FOR AUX.PRDS CONTROL VALVES**

**TABLE-V-C  
MANDATORY SPARES**

- Vendor to work out quantity of spare as per logic specified by customer in the below table.
- Vendor to indicate the make/model of each of the items listed below.
- Duplicate items should not be quoted as mandatory spare.

1	MS to Aux. steam system (HC PRV)	4-00-306-40721	Qty for 3 units as per Indent :3	
	Item	Logic	Qty reqd	UNIT
	Pneumatic and electro-hydraulic actuator assembly	10% or 1 No. of each type,model and rating, whichever is more	1	NO
	Position feed back transmitter	20% or 2 Nos. of each type, whichever is more.	2	NO
	Valve trim (including cage, plug, stem, seat rings, guide bushings etc.)	10% or One Set for each type whichever is more.	1	SET
	Diaphragms, O' rings, seals etc.	200% of all types, make etc.	6	NO
	Pneumatic air-filter/Regulator of each type, make, rating etc.	10% or 2 Nos. whichever is more	2	NO
	Pressure Gauges of all types, make, rating etc.	10% or 2 Nos. whichever is more	2	NO
	Solenoid valves	10% or 2 Nos. whichever is more	2	NO
	Air lock relays	10% or 2 Nos. whichever is more	2	NO
	Pneumatic relays	10% or 2 Nos. whichever is more	2	NO
	Positioner unit	20% or 1 Nos. of each type, whichever is more.	1	NO
2	CRH to Aux. steam system(LC PRV)	4-00-306-40724	Qty for 3 units as per Indent :3	
	Item	Logic	Qty reqd	UNIT
	Pneumatic and electro-hydraulic actuator assembly	10% or 1 No. of each type,model and rating, whichever is more	1	NO
	Position feed back transmitter	20% or 2 Nos. of each type, whichever is more.	2	NO
	Valve trim (including cage, plug, stem, seat rings, guide bushings	10% or One Set for each type whichever is more.	1	SET



**Bharat Heavy Electricals Limited  
Piping Centre Chennai-17**

Specification Number	Rev.no.	Sheet Number
PC:TSP:APRDS:BARH	00	16 of 27

**TECHNICAL SPECIFICATION FOR AUX.PRDS CONTROL VALVES**

	etc.)			
	Diaphragms, O' rings, seals etc.	200% of all types, make etc.	6	NO
	Pneumatic air-filter/Regulator of each type, make, rating etc.	10% or 2 Nos. whichever is more	2	NO
	Pressure Gauges of all types, make, rating etc.	10% or 2 Nos. whichever is more	2	NO
	Solenoid valves	10% or 2 Nos. whichever is more	2	NO
	Air lock relays	10% or 2 Nos. whichever is more	2	NO
	Pneumatic relays	10% or 2 Nos. whichever is more	2	NO
	Positioner unit	20% or 1 Nos. of each type, whichever is more.	1	NO
<b>3</b>	<b>CEP Spray to APRDS valves</b>		<b>Qty for 3 units as per Indent : 6 nos each</b>	
	<b>High capacity spray control valve</b>	<b>4-00-306-40727</b>		
	<b>Item</b>	<b>Logic</b>	<b>Qty reqd</b>	<b>UNIT</b>
	Pneumatic and electro-hydraulic actuator assembly	10% or 1 No. of each type,model and rating, whichever is more	1	NO
	Position feed back transmitter	20% or 2 Nos. of each type, whichever is more.	2	NO
	Valve trim (including cage, plug, stem, seat rings, guide bushings etc.)	10% or One Set for each type whichever is more.	1	SET
	Diaphragms, O' rings, seals etc.	200% of all types, make etc.	12	NO
	Pneumatic air-filter/Regulator of each type, make, rating etc.	10% or 2 Nos. whichever is more	2	NO
	Pressure Gauges of all types, make, rating etc.	10% or 2 Nos. whichever is more	2	NO
	Solenoid valves	10% or 2 Nos. whichever is more	2	NO
	Air lock relays	10% or 2 Nos. whichever is more	2	NO
	Pneumatic relays	10% or 2 Nos. whichever is more	2	NO



**Bharat Heavy Electricals Limited  
Piping Centre Chennai-17**

Specification Number	Rev.no.	Sheet Number
PC:TSP:APRDS:BARH	00	17 of 27

**TECHNICAL SPECIFICATION FOR AUX.PRDS CONTROL VALVES**

	Positioner unit	20% or 1 Nos. of each type, whichever is more.	1	NO
	<b>Low capacity spray control valve</b>	<b>4-00-306-40728</b>	<b>Qty reqd</b>	<b>UNIT</b>
	Pneumatic and electro-hydraulic actuator assembly	10% or 1 No. of each type,model and rating, whichever is more	1	NO
	Position feed back transmitter	20% or 2 Nos. of each type, whichever is more.	2	NO
	Valve trim (including cage, plug, stem, seat rings, guide bushings etc.)	10% or One Set for each type whichever is more.	1	SET
	Diaphragms, O' rings, seals etc.	200% of all types, make etc.	12	NO
	Pneumatic air-filter/Regulator of each type, make, rating etc.	10% or 2 Nos. whichever is more	2	NO
	Pressure Gauges of all types, make, rating etc.	10% or 2 Nos. whichever is more	2	NO
	Solenoid valves	10% or 2 Nos. whichever is more	2	NO
	Air lock relays	10% or 2 Nos. whichever is more	2	NO
	Pneumatic relays	10% or 2 Nos. whichever is more	2	NO
	Positioner unit	20% or 1 Nos. of each type, whichever is more.	1	NO
<b>4</b>	<b>HC PRV D/s. Desuperheater</b>	<b>4-00-306-40722</b>	<b>Qty for 3 units as per Indent : 3</b>	
	<b>Item</b>	<b>Logic</b>	<b>Qty reqd</b>	
	Pneumatic and electro-hydraulic actuator assembly	10% or 1 No. of each type,model and rating, whichever is more	1	NO
	Position feed back transmitter	20% or 2 Nos. of each type, whichever is more.	2	NO
	Valve trim (including cage, plug, stem, seat rings, guide bushings etc.)	10% or One Set for each type whichever is more.	1	SET
	Diaphragms, O' rings, seals etc.	200% of all types, make etc.	6	NO
	Pneumatic air-filter/Regulator of each type, make, rating etc.	10% or 2 Nos. whichever is more	2	NO
	Pressure Gauges of all types, make, rating etc.	10% or 2 Nos. whichever is more	2	NO



**Bharat Heavy Electricals Limited  
Piping Centre Chennai-17**

Specification Number	Rev.no.	Sheet Number
PC:TSP:APRDS:BARH	00	18 of 27

**TECHNICAL SPECIFICATION FOR AUX.PRDS CONTROL VALVES**

	Solenoid valves	10% or 2 Nos. whichever is more	2	NO
	Air lock relays	10% or 2 Nos. whichever is more	2	NO
	Pneumatic relays	10% or 2 Nos. whichever is more	2	NO
	Positioner unit	20% or 1 Nos. of each type, whichever is more.	1	NO
<b>5</b>	<b>LT header Desuperheater</b>	<b>4-00-306-40725</b>	<b>Qty for 3 units as per Indent :3</b>	
	<b>Item</b>	<b>Logic</b>	<b>Qty reqd</b>	<b>UNIT</b>
	Pneumatic and electro-hydraulic actuator assembly	10% or 1 No. of each type,model and rating, whichever is more	1	NO
	Position feed back transmitter	20% or 2 Nos. of each type, whichever is more.	2	NO
	Valve trim (including cage, plug, stem, seat rings, guide bushings etc.)	10% or One Set for each type whichever is more.	1	SET
	Diaphragms, O' rings, seals etc.	200% of all types, make etc.	6	NO
	Pneumatic air-filter/Regulator of each type, make, rating etc.	10% or 2 Nos. whichever is more	2	NO
	Pressure Gauges of all types, make, rating etc.	10% or 2 Nos. whichever is more	2	NO
	Solenoid valves	10% or 2 Nos. whichever is more	2	NO
	Air lock relays	10% or 2 Nos. whichever is more	2	NO
	Pneumatic relays	10% or 2 Nos. whichever is more	2	NO
	Positioner unit	20% or 1 Nos. of each type, whichever is more.	1	NO



**Bharat Heavy Electricals Limited**  
**Piping Centre Chennai-17**

Specification Number	Rev.no.	Sheet Number
PC:TSP:APRDS:BARH	00	19 of 27

**TECHNICAL SPECIFICATION FOR AUX.PRDS CONTROL VALVES**

**Quality Assurance, Inspection and Testing**

1.0 General:

1.1 All equipment covered under this specification shall be subject to inspection and test by the purchaser during manufacture, erection and commissioning. The approval of the purchaser of the results of the tests and inspection will not however, prejudice the right of the owner to reject the equipment if it does not comply with the specification when erected or does not give complete satisfactory service. The cost of all such tests shall be borne by the contractor.

1.2 Testing / Inspection procedures as detailed herein to give a basic quality control programme to be followed by the Bidder, are in no way comprehensive and in no way form a complete quality assurance programme. Any other inspection stage not mentioned in these clauses but required as per the Bidder's process control shall be deemed to be included. Any tests necessary from operation, safety and reliability point of view shall also be included. Such tests shall be subject to the approval / recommendation of the Purchaser.

1.3 The Bidder shall furnish the quality control procedures to be adopted for assuring quality of each equipment under this specification from the receipt of material at site, during storage, erection, pre-commissioning to final trial run and commissioning of the valves. These procedures shall necessarily include all checks / tests conducted at site for preservation, pre-assembly, alignment, positioning of equipment, foundation preparation, welding / bolting, heat



**Bharat Heavy Electricals Limited**  
**Piping Centre Chennai-17**

Specification Number	Rev.no.	Sheet Number
PC:TSP:APRDS:BARH	00	20 of 27

**TECHNICAL SPECIFICATION FOR AUX.PRDS CONTROL VALVES**

treatment, non-destructive examination, hydraulic test, performance test etc. The above shall be discussed and finalised with the Purchaser.

2.0 Shop Tests:

2.1 The contractor shall permit the Purchaser, if he so desires to maintain one or more of his representatives in the Contractor's shops and/or at the shops of his sub-contractors for the purpose of inspecting the various steps in the shop fabrication and the various tests to be performed for the materials supplied under this specification. The Purchaser's representative(s) shall have complete access to all parts of the shop wherein work under this specification is to be performed.

2.2 The contractor shall adopt good quality control procedures and provide inspection in his works and that of his sub-contractors to ensure the mechanical accuracy of components, compliance with drawings, identify and acceptability of all material, part and equipment. He shall conduct all tests required to ensure that the equipment furnished conforms to the requirements of the applicable codes. All tests and test procedures proposed by the manufacturer/fabricator shall be submitted to the purchaser for his prior approval. The purchaser shall be notified well in advance of the fabrication and major tests of the appurtenances and equipment, for the purpose of making general inspections and progress reports.

2.3 The Purchaser's representative shall have full access to the shops where the equipment to be supplied is being tested and all test records including records on heat treatment, radiography, ultrasonic test, magnetic particle test, material



**Bharat Heavy Electricals Limited**  
**Piping Centre Chennai-17**

Specification Number	Rev.no.	Sheet Number
PC:TSP:APRDS:BARH	00	21 of 27

**TECHNICAL SPECIFICATION FOR AUX.PRDS CONTROL VALVES**

analyses etc. shall be made available to him. When the contractor offers finished equipment for final inspection, notice of at least 15 days shall be given to the purchaser to enable his inspector to plan and carry out the inspection.

2.4 No material shall be despatched to the site from the manufacturers works until the owner has arranged for and carried out inspection to his satisfaction or has waived this requirement in writing.

2.5 Material test and analysis:

All materials shall be furnished in strict accordance with the applicable codes and the detailed specifications herein. All sources of material shall be disclosed and relevant test certificates giving precise details of identification of material, the physical and chemical properties of the material shall be submitted to the owner for approval. Test coupons shall be cast from the same melt for the body & disc.

2.6 Shell Test:-

All valves shall be subjected to shell test as per ANSI B16.34 and MSS-SP-61. All gaskets used for test shall be of the same material and design as specified for the finished products. Where mechanical gasket joints are broken following tests, new gaskets shall be fitted with the equipment and the joints shall be re-tested.

2.7 100% visual check shall be carried out for dimensions, end connection details and Surface finish of the equipment.

2.8 The complete inspection shall be carried out as per the owner's quality plan.

2.9 The inspection shall be carried out as per the drawing approved by the purchaser



**Bharat Heavy Electricals Limited**  
**Piping Centre Chennai-17**

Specification Number	Rev.no.	Sheet Number
PC:TSP:APRDS:BARH	00	22 of 27

**TECHNICAL SPECIFICATION FOR AUX.PRDS CONTROL VALVES**

**Section VII**

**Documents to be furnished along with the offer**

- Note: a) All documents shall be in ENGLISH language only  
b) Only units followed in this specification are to be used.

Sl.no	Description	To be filled by the bidder. Bidder's drawing or document reference (if not furnished "not furnished" with reason
1.0	General arrangement drawing of the valves with operators and other special accessories indicating clearly  a) overall dimensions,  b) Weight of valve, actuator & special accessories,  c) Model no.  d) Make & country of Manufacture,  e) Rating/Design code  f) Type  g) End connection details  h) Type of operator  i) Make of operator and Model No.  j) Valve Tag nos.	
2.0	Cross sectional drawing of the valve with operators and special accessories indicating minimum the following:	



**Bharat Heavy Electricals Limited**  
**Piping Centre Chennai-17**

Specification Number	Rev.no.	Sheet Number
PC:TSP:APRDS:BARH	00	23 of 27

**TECHNICAL SPECIFICATION FOR AUX.PRDS CONTROL VALVES**

3.0	<p>i) Names of all parts</p> <p>ii) Material of construction of all parts(Material specification shall not be in general terms like carbon steel, Alloy steel etc. Material specification shall conform to International standards. In case of Material specification other than ASTM, equivalent ASTM material specification to be indicated. No part of the valve to be left in the Tabulation).</p> <p>Minimum the following parts to be covered if applicable.</p> <ul style="list-style-type: none"><li>a) Body</li><li>b) Bonnet, Cap</li><li>c) Disc</li><li>d) Stem</li><li>e) Plug</li><li>f) Disc seat</li><li>g) Stem guide</li><li>h) Gasket</li><li>i) Gland packing</li><li>j) Bolts &amp; studs</li></ul>	
-----	--	--



**Bharat Heavy Electricals Limited**  
**Piping Centre Chennai-17**

Specification Number	Rev.no.	Sheet Number
PC:TSP:APRDS:BARH	00	24 of 27

**TECHNICAL SPECIFICATION FOR AUX.PRDS CONTROL VALVES**

	<p>k) Nuts</p> <p>l) Hand wheel</p> <p>iii) Weight of all parts</p> <p>iv) Erection, commissioning and Mandatory Spares identification along with their Quantity.</p> <p>v) Weight of valve &amp; actuator separately</p> <p>Total weight and flooded weight</p> <p>vi) Class rating as per ASME B16.34</p> <p>vii) Make &amp; Country of Manufacture</p> <p>viii) Actuator Make &amp; Type</p> <p>ix) End connection details</p> <p>Relevant catalogues for the valves</p>	
4.0	List of Tender deviations (It will be presumed	
5.0	that the bidder has no tender deviations in case bidder failing to furnish the same).	

Certified that all the information called for is available in the document or drawing indicated above.

Certified that our supply of valves will be in line with the Technical specification except the deviations furnished in Table IIIA and in the list of Tender deviations enclosed if any.

(Signature of the bidder)



**Bharat Heavy Electricals Limited  
Piping Centre Chennai-17**

Specification Number	Rev.no.	Sheet Number
PC:TSP:APRDS:BARH	00	25 of 27

**TECHNICAL SPECIFICATION FOR AUX.PRDS CONTROL VALVES**

**SECTION VIII**

**Documents to be furnished after award of the contract**

- Note:
- a) All documents shall be in ENGLISH language only
  - b) Only units followed in this specification are to be used.
  - c) All documents shall contain the project name
  - d) Applicable valve tag nos.

Sl.no	Description	Ref. Drawing	No of days reqd. To submit for approval after LOA / TOA or to resubmit for approval after BHEL comments.	No. of copies to be sent for approval.	No of days to furnish final drg after final approval.	No of copies to be furnished after final approval.
1.0	General arrangement drawing as per point 1 , section VII.		15	5	5	15
2.0	Cross sectional drawing as per point 2 , section VII		15	5	5	15
3.0	Applicable catalogue of valve.		15	5	5	15
4.0	Erection, commissioning, operation and maintenance Manuel containing minimum of the following detail.		LATER	5	5	15



**Bharat Heavy Electricals Limited**  
**Piping Centre Chennai-17**

Specification Number	Rev.no.	Sheet Number
PC:TSP:APRDS:BARH	00	27 of 27

**TECHNICAL SPECIFICATION FOR AUX.PRDS CONTROL VALVES**

	1) General arrgt. & cross sectional arrgt. Drgs as per point 1&2 of section VII respectively		15	5	5	15
	2) Actuator data sheet and wiring diagram of actuators.					
	3) List of Ball & Roller bearing schedule.					
	4) List of lubrication oil schedule					
	5) Do's and Do not's for valves & actuators.					
	6) Erection procedure & precautions to be taken.					
	7) Commissioning procedure & precautions to be taken.					
	8) Operating & maintenance instructions.					
5.0	Test certificates.		Not Applicable.	Nil	45	15



**Bharat Heavy Electricals Limited**  
**Piping Centre Chennai-17**

Specification Number	Rev.no.	Sheet Number
PC:TSP:APRDS:BARH	00	27 of 27

**TECHNICAL SPECIFICATION FOR AUX.PRDS CONTROL VALVES**

	1) Raw material test certificates (chemical & mechanical)					
	2) Hydro test certificates.					
	3) Seat test certificates					
	4) Back seat test certificates					
	5) NDT & other test certificates as per ASME B 31.1					
6.0	IBR and other mandatory requirements if required.		Not Applicable	Nil	45	15
7.0	Drawings in sl no: 1.0 & 2.0 recorded in CD		Not Applicable	Nil	60	15

Certified that the drawings / documents will be submitted / furnished as per the above Table.

(Signature of the Bidder)

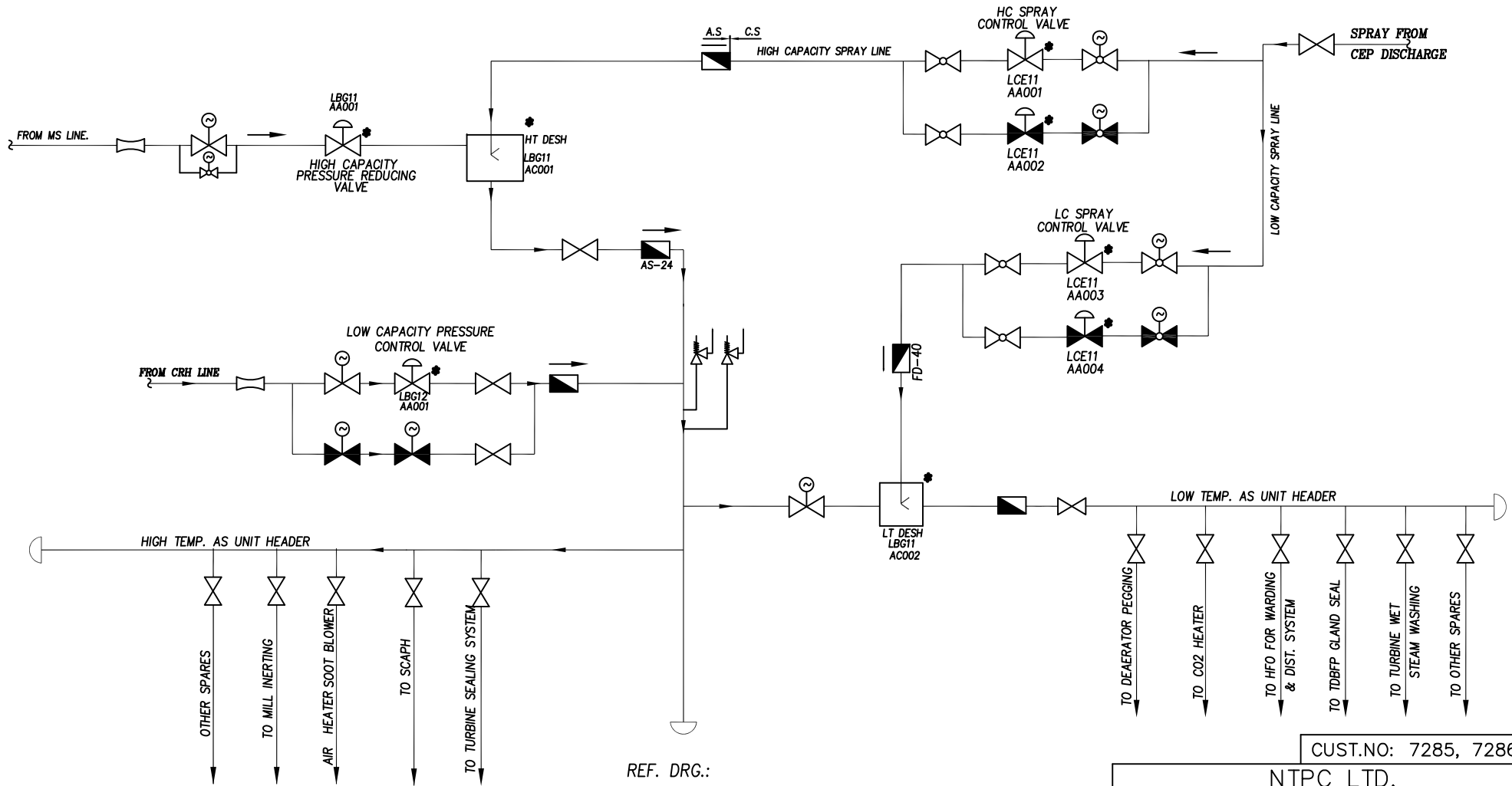

REF. DRG.:

1. P&ID OF AUXILIARY STEAM SYSTEM  
NTPC DRG NO BARH-1-SG-M-52-LBG-0013
- 2.\* DENOTES ITEMS TO BE DELIVERED BY THE BIDDER

CUST.NO: 7285, 7286 & 7287			
<b>NTPC LTD.</b> BARH STPP,STAGE-1(3X660MW) POWER CYCLE PIPING PACKAGE			
DRAWN	CHECKED	APPROVED	DATE
E.KRITHIGA	C.SARAVANAN	R.PRABA	28.05.15
TITLE		DRAWING No	
AUX. PRDS STATION SCHEME		4-00-306-40729/00	

CI 12/A



# CONTROL VALVE SPECIFICATION SHEET

( IN ACCORDANCE WITH I.S.A. FORM S20.51 )

PROJECT:  
NTPC-BARH STPP, STAGE-I(3X660MW)

CUST.No:7285,7286&7287

**GENERAL: THIS IS TO BE READ ALONG WITH TECHNICAL SPECIFICATION** PC: TSP: APRDS: BARH

- |  |                                |
|--|--------------------------------|
| 1. Valve tag No. : LBG11 AA001                     | 5. Manufacturer : *            |
| 2. Service : High capacity pressure reducing valve | 6. Model No. : *               |
| 3. Line No./Vessel No. :                           | 7. Rating : As per ASME B16.34 |
| 4. Qty. required per unit : ONE                    | 8. Total Qty Required : 3 Nos. |

**BODY:**

- |  |  |
|--|--|
| 9. Type : Thru <input checked="" type="checkbox"/> 3 Way <input type="checkbox"/>  | 16. Bonnet type : Standard <input type="checkbox"/> Finned <input checked="" type="checkbox"/> |
| Z type <input type="checkbox"/> Angle <input type="checkbox"/>                     | Extended <input checked="" type="checkbox"/> Pr. seal <input type="checkbox"/>                 |
| 10. Form : Globe <input checked="" type="checkbox"/> Ball <input type="checkbox"/> |  |
| Butterfly <input type="checkbox"/>   |  |
| 11. Size : *   | 17. Material : Body : ASTM SA182F91  |
| 12. Port Size : *  | Packing: GRAFOIL   |
| 13. Connecting pipe sizes:   | Bolting : *  |
| Control valve Inlet : OD 219.1 x 32(A335P91)                                       | 18. Flow direction : HORIZONTAL  |
| Control valve Outlet : ID 345 x 64.09(A335P91)                                     | 19. Suitable matching pieces to match with pipe size specified shall be offered.               |
| 14. Body rating : As per ASME B16.34   |  |

- |  |   |                             |
|--|---|-----------------------------|
| 15. Type of end connections : Screwed <input type="checkbox"/> | BW <input checked="" type="checkbox"/> (Steam and spray side) | SW <input type="checkbox"/> |
| NPI <input type="checkbox"/>                                   | BSPT <input type="checkbox"/>                                 | BS <input type="checkbox"/> |
| Flanged <input type="checkbox"/>                               | <input type="checkbox"/>                                      | <input type="checkbox"/>    |
| ANSI <input type="checkbox"/>                                  | DIN <input type="checkbox"/>                                  |                             |

Edge Preparation as per BPS.

**TRIM:**

- |   |  |                      |
|---|--|----------------------|
| 20. No. of ports : *  | 24. Stem material :                              | } 440C OR EQUIVALENT |
| 21. Type : Balanced <input checked="" type="checkbox"/> Unbalanced <input type="checkbox"/>                       | 25. Plug material :                              |                      |
| 22. Plug characteristics: <del>L/LV/EP</del> / <del>MODIFIED EP</del>   | 26. Seat material :                              |                      |
| 23. Guiding : Cage <input checked="" type="checkbox"/> Port <input type="checkbox"/> Top <input type="checkbox"/> | 27. Disc material :                              |                      |
| Bottom <input type="checkbox"/>   | 28. stem guide material :                        |                      |
|   | 29. Cage Material : F22 Ion Nitrided (or) Better |                      |

**ACTUATOR:**

- |  |  |
|--|--|
| 30. Type : Electric <input type="checkbox"/>                                     | 34. Diaphragm/Cylinder pressure at Valve full open : *             |
| Hydraulic <input type="checkbox"/> Pneumatic <input checked="" type="checkbox"/> | Valve full close : *   |
| DA/RA(Air To Close)  | 35. Force required for process & Force available at actuator. : *  |
| 31. Size : *   | 36. Actuator sizing ΔP : *   |
| 32. Supply : 5-6 Kg/cm <sup>2</sup>  | 37. If actuator electric fill in data sheet as per annexure : NAPL |
| Shut off Pressure: 6 Kg/cm <sup>2</sup>  | furnished and shall comply with annexure-I specification.          |
| 33. Failsafe position : Stayput <input checked="" type="checkbox"/>              |  |
| Full Close <input type="checkbox"/> Full Open <input type="checkbox"/>           |  |

00	28.05.15	FRESH ISSUE	E.KRITHIGA	C.SARAVANAN	R.PRABA
REV	DATE	ALTERATION	PREPARED	APPD./C&I	APPROVED

DRG. NO:

4-00-306-40721

REV

00

**POSITIONER:**

38. Type : Pneumatic  Electronic   
 DA/RA Electro Pneumatic   
 (SMART WITH FAIL FREEZE FACILITY)#

39. If Electronic : Type :  
 Model : Solid plate deversing contactors

Main contactor : Solid state thyristor:   
 Relay Switching :

Also refer annexure - II  
 position indicator reqd. for Valve & VCB

40. If Pneumatic : Type :  
 Model : \*  
 Split range : Yes  No   
 Controller Input & Output Signal Value : 4-20 mA  
 Air supply : 45 PSIG  
 Input/Output Pr. guage: Required : Yes  No   
 By pass provision : Yes  No   
 Action : Direct  Reverse  Both   
 Cam : =%  Linear  Both

**ACCESSORIES:**

41. Handwheel : Yes  Side  Top   
 42. Air filter : Yes  No   
 Filter Size : 5 Micron  25 Micron   
 43. Limit Switches : Yes  No   
 Qty. : 1 at full open & 1 at full close  
 Rating : 240v. 5Amp. ac  
 No of contacts per switch : 2No + 2NC

44. Solenoid valve to effect  
 Stayput : Yes  No   
 Type : 3 Way universal: Yes  No   
 Rating : 24V DC 2 wire  
 Class H coil : Yes  No

45. Vol. booster : Yes  No   
 46. Travel time : \*  
 47. Installation : Indoor  Outdoor   
 48. All accessories enclosure : IP55

49. Isolated Position transmitter : Yes  No   
 Type : Pneumatic :  Electronic Non contact type   
 Rating : 2 wire 24V DC:   
 Output : 4-20 ma :  3-15 paig   
 50. Torque Switches : Yes  No   
 Qty. :  
 Rating :  
 51. Air lock : Yes  No   
 Function : TO EFFECT STAYPUT  
 Type \* : 3 Way single acting   
 : 3 Way double acting   
 52. Ambience : Dusty corrosive   
 Toxic hazardous :   
 53.1. Local position Indicator : Required.  
 53.3 Integral JB : 36 Way JB required  
 53.4 All electrical terminating : plug & socket type

**MISCELLANEOUS:**

54. Seat leakage : FCI 70.2 class  CLASS IV <sup>\$</sup>  
 I.S.A :

55. Approx. weight (total) : \*  
 56. Space requirements for online servicing : \*

57. Valve sizing as per ISA 75.01 : Yes  No   
 58. Noise Level : Less than 85 DBA at 1m from Valve & Piping System.  
 59. Intertubing Diagram : As per Enclosed.  
 60. Performance Data  
 Linearity : ± 1 % Hysterisis : ± 0.5 %  
 Sensitivity : ± 0.5 % Accuracy (overall) : ± 2 %

**VALVE SIZING DATA:**

61. Medium : SH Steam  Sat. Steam   
 Water

62. Flow rate in T/Hr  
 63. Operating inlet pressure in Kg/cm<sup>2</sup> (a)  
 64. Operating inlet temperature in °C  
 65. Outlet pressure in Kg/cm<sup>2</sup> (a)  
 66. Viscosity : --  
 67. Operating (required) Cv  
 68. Operating noise level at 1.0 metre from valve surface  
 69. Outlet velocity

CONDITION				
1	2	3	4	5
REFER DRAWING No. 4-00-306-40723 FOR VALVE SIZING DATA				
REFER STANDARD TABLE				
<85	dba	(for all conditions)		

28.05.15	E.KRITHIGA	C.SARAVANAN	R.PRABA	DRG. NO:	4-00-306-40721	REV	00
DATE	PREPARED	APPD./C&I	APPROVED				

**DESIGN DATA:**

	(A)	(B)
	Steam	Spray

70. Design Pressure Kg/cm<sup>2</sup>(g) : 272.4 42 }\*

71. Design Temperature °C : 546 100 }\*

72. Rated/Design/Selected Cv of valve : \*

73. Velocity restriction : \*

74. Operating lift restriction : 10 to 80 %<sup>\$</sup>.

\* {MAX.CLASS RATING BETWEEN (A)&(B) SHALL BE THE CLASS RATING FOR THE TOTAL VALVE }

75. lift at various operating Conditions 1 TO 6 : \*

76. Down stream limitations : \*

77. Up stream limitations : \*

78. Increase in signal Air : To open the Valve

**TESTING/INSPECTION:**

79. Hydraulic test report : Yes  No

80. Radiography : Critical Parts :  Total   
Not required :

81. IBR test report : Req'd. :

82. Type test : Capacity Evolution by \*  
ISA S39.2/5 39.4 : Required

83. Valve functional test : Yes  No

\* Type test to be done atleast for one no on this consignment.

84. Accessories functional : Yes  No   
Test :

85. Seat leakage test : Yes  No

86. Material test report : Yes  No

87. Customer Inspection :  
In process : Yes  No   
Final : Yes  No

88. Third Party inspection : Yes  No

**DOCUMENTATION: (Required)**

89. With bid. (3 sets)

Catalogues : Yes  No

Dimensional drawing : Yes  No

All data sheets : Yes  No

Recommendation / Limitation : Yes  No

Confirmatory report : Yes  No

Contrary report : Yes  No

Deviation report : Yes  No

90. Quality plan : Yes  No

91. With equipment :

Dimensional drawing : 15 Sets

O & M \*\* : --do--

Data Sheets : --do--

Test certificate : 1CD + 3 Sets

92. Valve sizing, actuator sizing, noise level calculations required with bid(with formulae) : Yes  No

93. --

**SPARES:**

94. Commissioning spares : \*

95. Mandatory spares : As per specification

96. 2/3 Years maintenance spares : \*

**OTHERS:**

97. Bidders experience list : Required  Not required

98. Operational feed back of such valves supplied elsewhere : Required  Not required

99. Equipment guarantee : Required  Not required

100. System guarantee : Required  Not required

101. Service contract for 5 Years : - To quote seperately

102. Commissioning of the valves : Required  Not required

**NOTES:**

1. \* DENOTES BIDDER TO SPECIFY; 2.\*\*VIDEO MANUAL PREFERRED; 3. \$ AS PER TENDER SPECIFICATION
4. # AFTER INSPECTION, SMART POSITIONER TO BE PACKED SEPARATELY ALONG WITH THE CONTROL VALVE AND MOUNTING ACCESSORIES. THE SAME WILL BE OPENED AND INSTALLED ONLY DURING COMMISSIONING.

28.05.15	E.KRITHIGA	C.SARAVANAN	R.PRABA	DRG. NO:	4-00-306-40721	REV
DATE	PREPARED	APPD./C&I	APPROVED	31		00

**HIGH CAPACITY DESUPERHEATER SPECIFICATION SHEET**

- 01. Designation/Tag No : Auxiliary steam line / LBG11 AC001
- 02. Quantity Required per unit : One
- 03. Total quantity : Three
- 04. Turndown ratio : Bidder to specify
- 05. Material : A 335 Gr.P91
- 06. Inlet connection/Outlet connection } : ID 345 x 64.09(A335P91)/  
(Steam side) } ID 500 x 82.56(A335P91)
- 07. End connection (Steam side) : Butt Welded
- 08. Spray water connection : OD 48.3 x 12.5(A335P22)
- 09. End connection : Butt Welded / Socket Welded
- 10. Mounting arrangement : Horizontal
- 11. Minimum straight length required U/S of Desuperheater : Bidder to specify.
- 12. Minimum distance required } : Bidder to specify.  
downstream of DSH }
- 13. Sizing Parameters : Refer Drg. No. 4-00-306-40723
- 14 . Design Pressure : 272.4 Kg/cm<sup>2</sup> (g)
- 15. Design Temperature : 546 °C
- 16. Minimum distance required in D/S } : Bidder to specify.  
of DESH for temp. control sensing element }
- 17. Minimum distance required in D/S } : Bidder to specify.  
of DESH for pressure control sensing element }
- 18. IBR Certification required : Yes
- 19. Testing/Inspection : As per purchaser approved vendor QP
- 20. Documents required during offer :

Catalogues, filled up data sheets, Sizing calculations, Turn down ration calculation, Detailed drawing with BOM, Material specifications, Weight, Special requirements such as Liner, Upstream & Downstream straight length, O & M manual. Quality plan indicating various checks for raw material in process & final inspection stage.

21. Documents required after Placement of Order

Catalogues, Final detailed drawing with BOM, Material } 20 sets plus  
specification, Weight,Final sizing, Turn down ratio calculation, } 2 sets on CD  
Testcertificates as per QP and O & M manual.

28.05.15	E.KRITHIGA	C.SARAVANAN	R.PRABA	DRG. NO:	4-00-306-40722	REV
DATE	PREPARED	APPD.	APPD/C&I	32		00

## NTPC-BARH STPP, STAGE-I (3X660MW)

## POWER CYCLE PIPING PACKAGE



## SIZING DATA FOR HIGH CAPACITY PRESSURE REDUCING VALVE, HT DESUPERHEATER &amp; HC SPRAY VALVES

S.NO		1	2	3	4
PARAMETERS		STARTUP (LOAD: 7.5+30%)  AUX. STEAM: FROM HP PRDS  LIVE STEAM PARAMETERS: 60-90 kg/sqcm 350-425 deg C	NORMAL OPERATION + CONT. STEAM EXTRACTIONS & PERIODICAL STEAM CONSUMPTION  AUX. STEAM: FROM HP PRDS  LIVE STEAM PARAMETERS: 255 kg/sqcm 540 deg C	NORMAL OPERATION + STARTUP OF OTHER UNIT  AUX. STEAM: FROM HP PRDS  LIVE STEAM PARAMETERS: 255 kg/sqcm 540 deg C	MECH. DESIGN PARAMETERS
1.0	INLET OF AUX. PRDS				
1.1	PRESSURE (kg/sqcm(a))	61.00	256.0	256.0	273.4
1.2	TEMPERATURE (deg C)	350	540	540	546
1.3	FLOW (t/hr)	44.26	68.22	161.09	
2.0	OUTLET OF AUX. PRDS (AFTER DESUPERHEATING)				
2.1	PRESSURE (kg/sqcm(a))	16.0	16.0	16.0	23.0
2.2	TEMPERATURE (deg C)	310	310	310	330
2.3	FLOW (t/hr)	44.26	74.71	176.42	
3.0	HC PRDS SPRAY WATER				
3.1	PRESSURE (kg/sqcm(a))	37.6	37.6	37.6	43.0
3.2	TEMPERATURE (deg C)	59	59	59	100
3.3	FLOW (t/hr)	0.00	6.49	15.33	

NOTES: - THIS SIZING TABLE TO BE USED FOR HC PRV (TAG NO: LBG11 AA001), HT DESUPERHEATER (TAG NO: LBG11 AC001) AND HC SPRAY VALVES (TAG NO: LCE11 AA001 & LCE11 AA002)

PREPARED	CHECKED	APPROVED	DATE	DRG.No. 4-00-306-40723	SH. 1 OF 1	REV. 00
E.KRITHIGA	C.SARAVANAN	R.PRABA	28.05.15			

CI 12/A



# CONTROL VALVE SPECIFICATION SHEET

( IN ACCORDANCE WITH I.S.A. FORM S20.51 )

**PROJECT:**  
NTPC-BARH STPP,STAGE-I(3X660MW)

**CUST.No:** 7285,7286&7287

**GENERAL:THIS IS TO BE READ ALONG WITH TECHNICAL SPECIFICATION** PC: TSP: APRDS: BARH

<p>1. Valve tag No. : LBG12 AA001</p> <p>2. Service : Low capacity Pressure Control valve</p> <p>3. Line No./Vessel No. :</p> <p>4. Qty. required per unit : 1 No.</p>	<p>5. Manufacturer : *</p> <p>6. Model No. : *</p> <p>7. Rating : ASME CL. 600</p> <p>8. Total Qty Required : 3 Nos.</p>
<p><b>BODY:</b></p> <p>9. Type : Thru <input checked="" type="checkbox"/> 3 Way <input type="checkbox"/> Z type <input type="checkbox"/> Angle <input type="checkbox"/> <input type="checkbox"/></p> <p>10. Form : Globe <input checked="" type="checkbox"/> Ball <input type="checkbox"/> Butterfly <input type="checkbox"/> <input type="checkbox"/></p> <p>11. Size : *</p> <p>12. Port Size : *</p> <p>13. Connecting pipe size : Inlet :OD 273x9.27(A106Gr.C) Outlet:OD 273X9.27(A106Gr.C)</p> <p>14. Body rating : ASME CL. 600</p>	<p>16. Bonnet type : Standard <input type="checkbox"/> Finned <input checked="" type="checkbox"/> Extended <input checked="" type="checkbox"/> Pr. seal <input type="checkbox"/> <input type="checkbox"/></p> <p>17. Material : Body : ASTM A 216 Gr WCC Packing: GRAFOIL Bolting : *</p> <p>18. Flow direction : HORIZONTAL</p> <p>19. Suitable matching pieces to match with pipe/bold size specified shall be offered.</p>

<p>15. Type of end connections : Screwed <input type="checkbox"/> NPI <input type="checkbox"/> Flanged <input type="checkbox"/> ANSI <input type="checkbox"/></p>	<p>BW <input checked="" type="checkbox"/> SW <input type="checkbox"/> BSPT <input type="checkbox"/> BS <input type="checkbox"/> <input type="checkbox"/> <input type="checkbox"/> DIN <input type="checkbox"/></p>
---	--

Edge Preparation as per BPS.

<p><b>TRIM:</b></p> <p>20. No. of ports : *</p> <p>21. Type : Balanced <input checked="" type="checkbox"/> Unbalanced <input type="checkbox"/></p> <p>22. Plug characteristics: <del>L/LV/EP</del> / <del>MODIFIED EP</del></p> <p>23. Guiding : Cage <input checked="" type="checkbox"/> Port <input type="checkbox"/> Top <input type="checkbox"/> Bottom <input type="checkbox"/></p>	<p>24. Stem material : } 25. Plug material : } 17.4 PH SST 26. Seat material : } OR EQUIVALENT 27. Disc material : } 28. stem guide material : } 29. --</p>
--	---

<p><b>ACTUATOR:</b></p> <p>30. Type : Electric Hydraulic <input type="checkbox"/> Pneumatic <input checked="" type="checkbox"/></p> <p>31. Size : * <input type="checkbox"/> DA/RA(Air To Close) <input checked="" type="checkbox"/></p> <p>32. Supply : 5-6 Kg/cm<sup>2</sup> Shut off Pressure: 6 Kg/cm<sup>2</sup></p> <p>33. Failsafe position : Stayput <input checked="" type="checkbox"/> Full Close <input type="checkbox"/> Full Open <input type="checkbox"/></p>	<p>34. Diaphragm/Cylinder pressure at Valve full open : * Valve full close : *</p> <p>35. Force required for process &amp; Force available at actuator. : *</p> <p>36. Actuator sizing ΔP : *</p> <p>37. If actuator electric fill in data sheet as per annexure : NAPL furnished and shall comply with annexure-I specification.</p>
---	---

00	28.05.15	FRESH ISSUE	E.KRITHIGA	C.SARAVANAN	R.PRABA	DRG. NO: 4-00-306-40724				REV 00
REV	DATE	ALTERATION	PREPARED	APPROVED	APPD/C&I					

**POSITIONER:**

38. Type : Pneumatic  Electronic   
 DA/RA Electro Pneumatic   
 (SMART WITH FAIL FREEZE FACILITY)#  
 39. If Electronic : Type :  
 Model : Solid plate deversing  
 contactors  
 Main contactor : Solid state thyristor:   
 Relay Switching :   
 Also refer annexure - II  
 position indicator reqd. for Valve & VCB

40. If Pneumatic : Type : \*  
 Model : \*  
 Split range : Yes  No   
 Controller Input & Output Signal Value : 4-20 mA  
 Air supply : 45 PSIG  
 Input/Output Pr. guage:  
 Required : Yes  No   
 By pass provision : Yes  No   
 Action : Direct  Reverse  Both   
 Cam : =%  Linear  Both

**ACCESSORIES:**

41. Handwheel : Yes  Side  Top   
 42. Air filter : Yes  No   
 Filter Size : 5 Micron  25 Micron   
 43. Limit Switches : Yes  No   
 Qty. : 1 at full open &  
 : 1 at full close  
 Rating : 240v. 5Amp. ac  
 No of contacts per switch : 2No + 2NC  
 44. Solenoid valve to effect  
 Stayput : Yes  No   
 Type : 3 Way universal: Yes  No   
 Rating : 24V DC 2 wire  
 Class H coil : Yes  No   
 45. Vol. booster : Yes  No   
 46. Travel time : \*  
 47. Installation : Indoor  Outdoor   
 48. All accessories enclosure : IP55\$

49. Isolated Position transmitter : Yes  No   
 Type : Pneumatic :  Electronic Non contact type   
 Rating : 2 wire 24V DC:   
 Output : 4-20 ma :  3-15 paig   
 50. Torque Switches : Yes  No   
 Qty. :  
 Rating :  
 51. Air lock : Yes  No   
 Function : TO EFFECT STAYPUT  
 Type \* : 3 Way single acting   
 : 3 Way double acting   
 52. Ambience : Dusty corrosive   
 Toxic hazardous :   
 53.1. Local position Indicator : Required.  
 53.2. Integral JB : 36 Way JB required  
 53.3. All electrical terminating : plug & socket type

**MISCELLANEOUS:**

54. Seat leakage : FCI 70.2 class  CLASS IV \$  
 I.S.A :    
 55. Approx. weight (total) : \*  
 56. Space requirements for online servicing : \*

57. Valve sizing as per ISA 75.01 Yes  No   
 58. Noise Level : Less than 85 DBA at 1m from Valve & Piping System.  
 59. Intertubing Diagram : As per Enclosed.  
 60. Performance Data  
 Linearity : ± 1 % Hyterisis : ± 0.5 %  
 Sensitivity : ± 0.5 % Accuracy (overall) : ± 2 %

**VALVE SIZING DATA:**

61. Medium : SH Steam  Sat. Steam  Water

S.No	1	2	3	4
PARAMETERS	Normal operation + Cont.steam extractions Aux. steam: from LP PRDS Reheat steam Parameters: Pr.: 24-45kg/sqcm; Temp:283-293 deg C	Normal flow Parameters	Max. flow Parameters	Mech Design Parameters
INLET OF PRV				
62 Pressure(kg/sqcm(a))	24.0	45	45	57.5
63 Temperature(deg C)	283	293	293	331
64 Flow(T/hr)	19.09	19.09	70.63	
OUTLET OF AUX.PRV				
65 Pressure(kg/sqcm(a))	16.0	16.0	16.0	23.0
66 Viscosity	Refer Standard table			
67 Operating(reqd) Cv				
68 Operating noise level at 1.0 mtr from valve surface	<85 dba(for all conditions)			
69 Outlet velocity	Bidder to specify			

28.05.15 E.KRITHIGA C.SARAVANAN R.PRABA DRG. NO: 4-00-306-40724 REV  
 DATE PREPARED APPD APPD/C&I 35 00

**DESIGN DATA:**

70. Design Pressure Kg/cm<sup>2</sup>(g) : 56.5 Kg/Cm<sup>2</sup>(g)
71. Design Temperature °C : 331 °C
72. Rated/Design/Selected Cv of valve : \*
73. Velocity restriction : \*
74. Operating lift restriction : 10 to 80 %.
75. lift at various operating Conditions 1 TO 6 : \*
76. Down stream limitations : \*
77. Up stream limitations : \*
78. Increase in signal Air : To open the Valve

**TESTING/INSPECTION:**

79. Hydraulic test report : Yes  No
80. Radiography : Critical Parts :  Total   
Not required :
81. IBR test report : Req'd. :
82. Type test : Capacity Evolution by \*  
ISA S39.2/5 39.4 : Required
83. Valve functional test : Yes  No
- \* Type test to be done atleast for one no on this consignment.
84. Accessories functional : Yes  No   
Test :
85. Seat leakage test : Yes  No
86. Material test report : Yes  No
87. Customer Inspection :  
In process : Yes  No   
Final : Yes  No
88. Third Party inspection : Yes  No

**DOCUMENTATION: (Required)**

89. With bid. (3 sets)
- Catalogues : Yes  No
- Dimensional drawing : Yes  No
- All data sheets : Yes  No
- Recommendation / Limitation : Yes  No
- Confirmatory report : Yes  No
- Contrary report : Yes  No
- Deviation report : Yes  No
90. Quality plan : Yes  No
91. With equipment :
- Dimensional drawing : 15 Sets
- O & M\*\* : --do--
- Data Sheets : --do--
- Test certificate : 1 CD + 3 Sets
92. Valve sizing, actuator sizing, noise level calculations required with bid(with formulae) : Yes  No
93. --

**SPARES:**

94. Commissioning spares : \*
95. Mandatory spares : As per specification
96. 2/3 Years maintenance spares : \*

**OTHERS:**

97. Bidders experience list : Required  Not required
98. Operational feed back of such valves supplied elsewhere : Required  Not required
99. Equipment guarantee : Required  Not required
100. System guarantee : Required  Not required
101. Service contract for 5 Years : - To quote seperately
102. Commissioning of the valves : Required  Not required

**NOTES:**

1. \* DENOTES BIDDER TO SPECIFY; 2.\*\*VIDEO MANUAL PREFERRED; 3. \$ AS PER TENDER SPECIFICATION
4. # AFTER INSPECTION, SMART POSITIONER TO BE PACKED SEPARATELY ALONG WITH THE CONTROL VALVE AND MOUNTING ACCESSORIES. THE SAME WILL BE OPENED AND INSTALLED ONLY DURING COMMISSIONING.

28.05.15	E.KRITHIGA	C.SARAVANAN	R.PRABA	DRG. NO:	4-00-306-40724	REV
DATE	PREPARED	APPD	APPD/C&I	36		00

**L.T. DESUPERHEATER SPECIFICATION SHEET**

01. Designation/Tag No : Auxiliary steam line / LBG11 AC002
02. Quantity Required per unit : One
03. Total quantity : Three
04. Turndown ratio : Bidder to specify
05. Material : ASTM A 106 Gr B
06. Inlet connection/Outlet connection } :  $\phi 457 \times 9.53(A106Gr.B)/$   
(Steam side) }  $\phi 457 \times 9.53(A106Gr.B)$
07. End connection (Steam side) : Butt Welded
08. Spray water connection : OD 48.3 x 5.08(A106Gr.B)
09. End connection : Butt Welded / Socket Welded
10. Mounting arrangement : Horizontal
11. Minimum straight length required : Bidder to specify.  
U/S of Desuperheater
12. Minimum distance required } : Bidder to specify.  
downstream of DSH }
13. Sizing Parameters : Refer Drg. No. 4-00-306-40726
- 14 . Design Pressure : 22 Kg / cm<sup>2</sup> (g)
15. Design Temperature : 330 °C
16. Minimum distance required in D/S } : Bidder to specify.  
of DESH for temp. control sensing element }
17. Minimum distance required in D/S } : Bidder to specify.  
of DESH for pressure control sensing element }
18. IBR Certification required : Yes
19. Testing/Inspection : As per purchaser approved vendor QP
20. Documents required during offer :

Catalogues, filled up data sheets, Sizing calculations, Turn down ration calculation, Detailed drawing with BOM, Material specifications, Weight, Special requirements such as Liner, Upstream & Downstream straight length, O & M manual Quality plan indicating various checks for raw material in process & final inspection stage.

21. Documents required after Placement of Order

Catalogues, Final detailed drawing with BOM, Material } 20 sets plus  
specification, Weight,Final sizing, Turn down ratio calculation, } 2 sets on CD  
Testcertificates as per QP and O & M manual.

28.05.15	E.KRITHIGA	C.SARAVANAN	R.PRABA	DRG. NO:	4-00-306-40725	REV
DATE	PREPARED	APPD.	APPD/C&I	37		00



NTPC-BARH STPP, STAGE-I (3X660MW) CUST. No: 7285, 7286, 7287  
 POWER CYCLE PIPING PACKAGE  
 SIZING DATA FOR LT DESUPERHEATER AND LC SPRAY VALVES

S.NO		1	2	3	4
PARAMETERS		NORMAL OPERATION + CONT.STEAM EXTRACTIONS  AUX. STEAM: FROM LP PRDS  REHEAT STEAM PARAMETERS: 24-45 kg/sqcm 283-293 deg C	NORMAL OPERATION + CONT.STEAM EXTRACTIONS & PERIODICAL STEAM CONSUMPTION  AUX. STEAM: FROM HP PRDS  LIVE STEAM PARAMETERS: 255 kg/sqcm 540 deg C	NORMAL OPERATION +STARTUP OF OTHER UNIT  AUX. STEAM: FROM HP PRDS  LIVE STEAM PARAMETERS: 255 kg/sqcm 540 deg C	MECH. DESIGN PARAMETERS
1.0	INLET OF DESUPERHEATER				
1.1	PRESSURE (kg/sqcm(a))	16.00	16.00	16.00	23.0
1.2	TEMPERATURE (deg C)	283	310	310	330
1.3	FLOW (t/hr)	15.83	39.95	130.16	
2.0	OUTLET OF DESUPERHEATER				
2.1	PRESSURE (kg/sqcm(a))	16.0	16.0	16.0	23.0
2.2	TEMPERATURE (deg C)	210	210	210	230
2.3	FLOW (t/hr)	16.78	42.35	137.99	
3.0	HC PRDS SPRAY WATER				
3.1	PRESSURE (kg/sqcm(a))	37.6	37.6	37.6	43.0
3.2	TEMPERATURE (deg C)	59	59	59	100
3.3	FLOW (t/hr)	0.95	2.4	7.83	

**NOTES: -**  
 THIS SIZING TABLE TO BE USED FOR LT DESUPERHEATER (TAG NO: LBG11 AC002) AND LC SPRAY VALVES (TAG NO: LCE11 AA003 & LCE11 AA004)

PREPARED	CHECKED	APPROVED	DATE	DRG.No. 4-00-306-40726	SH. 1 OF 1	REV. 00
E.KRITHIGA	C.SARAVANAN	PRABA	28.05.2015			

CI 12/A



# CONTROL VALVE SPECIFICATION SHEET

( IN ACCORDANCE WITH I.S.A. FORM S20.51 )

PROJECT: NTPC-BARH STPP,STAGE-I(3X660MW)

CUST.No: 7285,7286&7287

**GENERAL:THIS IS TO BE READ ALONG WITH TECHNICAL SPECIFICATION** PC:TSP:APRDS

- |   |                                |
|---|--------------------------------|
| 1. Valve tag No. : LCE11 AA001 & LCE11 AA002          | 5. Manufacturer : *            |
| 2. Service : High capacity Spray Control valve        | 6. Model No. : *               |
| 3. Line No./Vessel No. :                              | 7. Rating : ASME CL. 300       |
| 4. Qty. required per unit : 2 Nos.(1 No. in each tag) | 8. Total Qty Required : 6 Nos. |

**BODY:**

- |   |   |
|---|---|
| 9. Type : Thru <input checked="" type="checkbox"/> 3 Way <input type="checkbox"/><br>Z type <input type="checkbox"/> Angle <input type="checkbox"/> | 16. Bonnet type : Standard <input checked="" type="checkbox"/> Finned <input type="checkbox"/><br>Extended <input type="checkbox"/> Pr. seal <input type="checkbox"/> |
| 10. Form : Globe <input checked="" type="checkbox"/> Ball <input type="checkbox"/><br>Butterfly <input type="checkbox"/>                            | 17. Material : Body : A105<br>Packing: GRAFOIL<br>Bolting : *   |
| 11. Size : *  | 18. Flow direction : HORIZONTAL   |
| 12. Port Size : *   | 19. Suitable matching pieces to match with pipe/bold size specified shall be offered.   |
| 13. Connecting pipe size: Inlet : OD 48.3x5.08(A106Gr.B)<br>Outlet : OD 48.3x5.08(A106Gr.B)   |   |
| 14. Body rating : ASME CL.300   |   |

- |  |  |                             |
|--|--|-----------------------------|
| 15. Type of end connections : Screwed <input type="checkbox"/> | BW <input checked="" type="checkbox"/> | SW <input type="checkbox"/> |
| NPI <input type="checkbox"/>                                   | BSPT <input type="checkbox"/>          | BS <input type="checkbox"/> |
| Flanged <input type="checkbox"/>                               | <input type="checkbox"/>               | <input type="checkbox"/>    |
| ANSI <input type="checkbox"/>                                  | DIN <input type="checkbox"/>           |                             |

Edge Preparation as per BPS.

**TRIM: MULTI STAGE, LOW RECOVERY / \***

- |  |                            |  |
|--|----------------------------|--|
| 20. No. of ports : *   | 24. Stem material :        | } SS316 SST Strain Hardened<br>OR EQUIVALENT |
| 21. Type : Balanced <input checked="" type="checkbox"/> Unbalanced <input type="checkbox"/>  | 25. Plug material :        |  |
| 22. Plug characteristics: <del>L/LV/EP</del> / <del>MODIFIED EP</del>  | 26. Seat material :        |  |
| 23. Guiding : Cage <input checked="" type="checkbox"/> Port <input type="checkbox"/> Top <input type="checkbox"/><br>Bottom <input type="checkbox"/> | 27. Disc material :        |  |
|  | 28. stem guide material: } |  |
|  | 29. --                     |  |

**ACTUATOR:**

- |   |   |
|---|---|
| 30. Type : Electric <input type="checkbox"/> Pneumatic <input checked="" type="checkbox"/><br>Hydraulic <input type="checkbox"/> DA/RA(Air To Close)    | 34. Diaphragm/Cylinder pressure at<br>Valve full open : *<br>Valve full close : *   |
| 31. Size : *  | 35. Force required for process &<br>Force available at actuator. : *  |
| 32. Supply : 5-6 Kg/cm <sup>2</sup><br>Shut off Pressure: 6 Kg/cm <sup>2</sup>  | 36. Actuator sizing ΔP : *  |
| 33. Failsafe position : Stayput <input checked="" type="checkbox"/><br>of valve. Full Close <input type="checkbox"/> Full Open <input type="checkbox"/> | 37. If actuator electric fill in<br>data sheet as per annexure : NAPL<br>furnished and shall comply<br>with annexure-I specification. |

00	28.05.15	FRESH ISSUE	E.KRITHIGA	C.SARAVANAN	R.PRABA	DRG. NO:	4-00-306-40727	REV	00
REV	DATE	ALTERATION	PREPARED	APPD.	APPD/C&I				

**POSITIONER:**

38. Type : Pneumatic  Electronic   
 DA/RA  Electro Pneumatic   
 (SMART WITH FAIL FREEZE FACILITY)#  
 39. If Electronic : Type :  
 Model : Solid plate deversing contactors  
 Main contactor : Solid state thyristor:   
 Relay Switching :   
 Also refer annexure - II  
 position indicator reqd. for Valve & VCB

40. If Pneumatic : Type : \*  
 Model : \*  
 Split range : Yes  No   
 Controller Input & Output Signal Value : 4-20 mA  
 Air supply : 45 PSIG  
 Input/Output Pr. guage:  
 Required : Yes  No   
 By pass provision : Yes  No   
 Action : Direct  Reverse  Both   
 Cam : =%  Linear  Both

**ACCESSORIES:**

41. Handwheel : Yes  Side  Top   
 42. Air filter : Yes  No   
 Filter Size : 5 Micron  25 Micron   
 43. Limit Switches : Yes  No   
 Qty. : 1 at full open & 1 at full close  
 Rating : 240v. 5Amp. ac  
 No of contacts per switch : 2No + 2NC  
 44. Solenoid valve to effect  
 Stayput : Yes  No   
 Type : 3 Way universal: Yes  No   
 Rating : 24V DC 2 wire  
 Class H coil : Yes  No   
 45. Vol. booster : Yes  No   
 46. Travel time : \*  
 47. Installation : Indoor  Outdoor   
 48. All accessories enclosure : IP55<sup>\$</sup>

49. Isolated Position transmitter : Yes  No   
 Type : Pneumatic :  Electronic Non contact type   
 Rating : 2 wire 24V DC:   
 Output : 4-20 ma :  3-15 paig   
 50. Torque Switches : Yes  No   
 Qty. :  
 Rating :  
 51. Air lock : Yes  No   
 Function : TO EFFECT STAYPUT  
 Type : 3 Way single acting   
 : 3 Way double acting   
 52. Ambience : Dusty corrosive   
 Toxic hazardous :   
 53.1. Local position Indicator : Required.  
 53.2. Integral JB : 36 Way JB required  
 53.3. All electrical terminating : plug & socket type

**MISCELLANEOUS:**

54. Seat leakage : FCI 70.2 class  CLASS IV<sup>\$</sup>  
 I.S.A :    
 55. Approx. weight (total) : \*  
 56. Space requirements for online servicing : \*

57. Valve sizing as per ISA 75.01 : Yes  No   
 58. Noise Level : Less than 85 DBA at 1m from Valve & Piping System.  
 59. Intertubing Diagram : As per Enclosed.  
 60. Performance Data  
 Linearity : ± 1 % Hysterisis : ± 0.5 %  
 Sensitivity : ± 0.5 % Accuracy (overall) : ± 2 %

**VALVE SIZING DATA:**

61. Medium : SH Steam  Sat. Steam   
 Water   
 62. Flow rate in T/Hr  
 63. Operating inlet pressure in Kg/cm<sup>2</sup> (a)  
 64. Operating inlet temperature in °C  
 65. Outlet pressure in Kg/cm<sup>2</sup> (a)  
 66. Viscosity : --  
 67. Operating (required) Cv  
 68. Operating noise level at 1.0 metre from valve surface  
 69. Outlet velocity

CONDITION				
1	2	3	4	5
REFER DRAWING No. 4-00-306-40723 FOR VALVE SIZING DATA				
REFER STANDARD TABLE				
<85	dba	(for all conditions)		

28.05.15	E.KRITHIGA	C.SARAVANAN	R.PRABA	DRG. NO:	4-00-306-40727	REV	00
DATE	PREPARED	APPD.	APPD/C&I				

**DESIGN DATA:**

70. Design Pressure Kg/cm<sup>2</sup>(g) : 42 Kg/Cm<sup>2</sup> (g)
71. Design Temperature °C : 100 °C
72. Rated/Design/Selected Cv of valve : \*
73. Velocity restriction : \*
74. Operating lift restriction : 10 to 80 %<sup>\$</sup>.
75. lift at various operating Conditions : \*
76. Down stream limitations : \*
77. Up stream limitations : \*
78. Increase in signal Air : To open the Valve

**TESTING/INSPECTION:** (AS PER M/S NTPC APPROVED QUALITY PLAN: )

79. Hydraulic test report : Yes  No
80. Radiography : Critical Parts :  Total   
Not required :
81. IBR test report : Req'd. :
82. Type test : Capacity Evolution by \*  
ISA S39.2/5 39.4 : Required
83. Valve functional test : Yes  No
- \* Type test to be done atleast for one no on this consignment.
84. Accessories functional : Yes  No   
Test :
85. Seat leakage test : Yes  No
86. Material test report : Yes  No
87. Customer Inspection :  
In process : Yes  No   
Final : Yes  No
88. Third Party inspection : Yes  No

**DOCUMENTATION:** (Required)

89. With bid. (3 sets)
- Catalogues : Yes  No
- Dimensional drawing : Yes  No
- All data sheets : Yes  No
- Recommendation / Limitation : Yes  No
- Confirmatory report : Yes  No
- Contrary report : Yes  No
- Deviation report : Yes  No
90. Quality plan : Yes  No
91. With equipment :
- Dimensional drawing : 15 Sets
- O & M\*\* : --do--
- Data Sheets : --do--
- Test certificate : 1 CD + 3 Sets
92. Valve sizing, actuator sizing, Cavitation check, noise level calculations required with bid(with formulae) : Yes  No
93. --

**SPARES:**

94. Commissioning spares : \*
95. Mandatory spares : As per specification
96. 2/3 Years maintenance spares : \*

**OTHERS:**

97. Bidders experience list : Required  Not required
98. Operational feed back of such valves supplied elsewhere : Required  Not required
99. Equipment guarantee : Required  Not required
100. System guarantee : Required  Not required
101. Service contract for 5 Years : - To quote seperately
102. Commissioning of the valves : Required  Not required

**NOTES:**

1. \* DENOTES BIDDER TO SPECIFY; 2.\*\*VIDEO MANUAL PREFERRED; 3. \$ AS PER TENDER SPECIFICATION
4. # AFTER INSPECTION, SMART POSITIONER TO BE PACKED SEPARATELY ALONG WITH THE CONTROL VALVE AND MOUNTING ACCESSORIES. THE SAME WILL BE OPENED AND INSTALLED ONLY DURING COMMISSIONING.

28.05.15	E.KRITHIGA	C.SARAVANAN	R.PRABA	DRG. NO:	REV
DATE	PREPARED	APPD.	APPD/C&I	4-00-306-40727	00

CI 12/A



# CONTROL VALVE SPECIFICATION SHEET

( IN ACCORDANCE WITH I.S.A. FORM S20.51 )

PROJECT:  
NTPC-BARH STPP,STAGE-I(3X660MW)

CUST.No: 7285,7286&7287

**GENERAL:THIS IS TO BE READ ALONG WITH TECHNICAL SPECIFICATION** PC: TSP: APRDS

- |  |                                |
|--|--------------------------------|
| 1. Valve tag No. : LCE11 AA003 & LCE11 AA004         | 5. Manufacturer : *            |
| 2. Service : Low capacity Spray Control valve        | 6. Model No. : *               |
| 3. Line No./Vessel No. :                             | 7. Rating : ASME CI 300        |
| 4. Qty. required per unit : 2 Nos.(1No. in each tag) | 8. Total Qty Required : 6 Nos. |

**BODY:**

- |  |   |
|--|---|
| 9. Type :<br>Thru <input checked="" type="checkbox"/> 3 Way <input type="checkbox"/><br>Z type <input type="checkbox"/> Angle <input type="checkbox"/><br><input type="checkbox"/> | 16. Bonnet type : Standard <input checked="" type="checkbox"/> Finned <input type="checkbox"/><br>Extended <input type="checkbox"/> Pr. seal <input type="checkbox"/><br><input type="checkbox"/> |
| 10. Form :<br>Globe <input checked="" type="checkbox"/> Ball <input type="checkbox"/><br>Butterfly <input type="checkbox"/> <input type="checkbox"/>                               | 17. Material : Body : A105<br>Packing: GRAFOIL<br>Bolting : *   |
| 11. Size : *   | 18. Flow direction : HORIZONTAL   |
| 12. Port Size : *  | 19. Suitable matching pieces to match with pipe size specified shall be offered.  |
| 13. Connecting pipe size: Inlet: OD 48.3 x 5.08(A106Gr.B)<br>Outlet: OD 48.3 x 5.08(A106Gr.B)  |   |
| 14. Body rating : ASME CI 300  |   |

- |  |  |                             |
|--|--|-----------------------------|
| 15. Type of end connections : Screwed <input type="checkbox"/> | BW <input checked="" type="checkbox"/> | SW <input type="checkbox"/> |
| NPI <input type="checkbox"/>                                   | BSPT <input type="checkbox"/>          | BS <input type="checkbox"/> |
| Flanged <input type="checkbox"/>                               | <input type="checkbox"/>               | <input type="checkbox"/>    |
| ANSI <input type="checkbox"/>                                  | DIN <input type="checkbox"/>           |                             |

Edge Preparation as per BPS.

**TRIM: MULTI STAGE, LOW RECOVERY / \***

- |  |                            |
|--|----------------------------|
| 20. No. of ports : *   | 24. Stem material :        |
| 21. Type : Balanced/Unbalanced   | 25. Plug material :        |
| 22. Plug characteristics: L/LV/EP/MODIFIED EP  | 26. Seat material :        |
| 23. Guiding : Cage <input checked="" type="checkbox"/> Port <input type="checkbox"/> Top <input type="checkbox"/><br>Bottom <input type="checkbox"/> | 27. Disc material :        |
|  | 28. stem guide material: } |
|  | 29. --                     |
- } SS316 SST Strain Hardened  
OR EQUIVALENT

**ACTUATOR:**

- |   |   |
|---|---|
| 30. Type :<br>Electric <input type="checkbox"/> Pneumatic <input checked="" type="checkbox"/><br>Hydraulic <input type="checkbox"/> DA/RA(Air To Close) <input checked="" type="checkbox"/> | 34. Diaphragm/Cylinder pressure at<br>Valve full open : *<br>Valve full close : *   |
| 31. Size : *  | 35. Force required for process &<br>Force available at actuator. : *  |
| 32. Supply : 5-6 Kg/cm <sup>2</sup><br>Shut off Pressure : 6 Kg/cm <sup>2</sup>   | 36. Actuator sizing ΔP : *  |
| 33. Failsafe position : Stayput <input checked="" type="checkbox"/><br>of valve.<br>Full Close <input type="checkbox"/> Full Open <input type="checkbox"/>                                  | 37. If actuator electric fill in<br>data sheet as per annexure : NAPL<br>furnished and shall comply<br>with annexure-I specification. |

00	28.05.15	FRESH ISSUE	E.KRITHIGA	C.SARAVANAN	R.PRABA
REV	DATE	ALTERATION	PREPARED	APPD	APPD/C&I

DRG. NO:

4-00-306-40728

REV

00

**POSITIONER:**

38. Type : Pneumatic  Electronic   
 DA/RA Electro Pneumatic   
 (SMART WITH FAIL FREEZE FACILITY)#  
 39. If Electronic : Type :  
 Model : Solid plate deversing  
 contactors  
 Main contactor : Solid state thyristor:   
 Relay Switching :   
 Also refer annexure - II  
 position indicator reqd. for Valve & VCB

40. If Pneumatic : Type : \*  
 Model : \*  
 Split range : Yes  No   
 Controller Input & Output Signal Value : 4-20 mA  
 Air supply : 45 PSIG  
 Input/Output Pr. guage:  
 Required : Yes  No   
 By pass provision : Yes  No   
 Action : Direct  Reverse  Both   
 Cam : =%  Linear  Both

**ACCESSORIES:**

41. Handwheel : Yes  Side  Top   
 42. Air filter : Yes  No   
 Filter Size : 5 Micron  25 Micron   
 43. Limit Switches : Yes  No   
 Qty. : 1 at full open &  
 : 1 at full close  
 Rating : 240v. 5Amp. ac  
 No of contacts per switch : 2No + 2NC  
 44. Solenoid valve as  
 Stayput : Yes  No   
 Type : 3 Way universal: Yes  No   
 Rating : 24V DC 2 wire  
 Class H coil : Yes  No   
 45. Vol. booster : Yes  No   
 46. Travel time : \*  
 47. Installation : Indoor  Outdoor   
 48. All accessories enclosure : IP55\$

49. Isolated Position transmitter : Yes  No   
 Type : Pneumatic :  Electronic Non contact type   
 Rating : 2 wire 24V DC:   
 Output : 4-20 ma :  3-15 paig   
 50. Torque Switches : Yes  No   
 Qty. :  
 Rating :  
 51. Air lock : Yes  No   
 Function : TO EFFECT STAYPUT  
 Type \* : 3 Way single acting   
 : 3 Way double acting   
 52. Ambience : Dusty corrosive   
 Toxic hazardous :   
 53.1. Local position Indicator: Required.  
 53.2. Integral JB : 36 Way JB required  
 53.3. All electrical terminating : plug & socket type

**MISCELLANEOUS:**

54. Seat leakage : FCI 70.2 class  CLASS IV \$  
 I.S.A :    
 55. Approx. weight (total) : \*  
 56. Space requirements for online servicing : \*

57. Valve sizing as per ISA 75.01 : Yes  No   
 58. Noise Level : Less than 85 DBA at 1m from Valve & Piping System.  
 59. Intertubing Diagram : As per Enclosed.  
 60. Performance Data  
 Linearity : ± 1 % Hysterisis : ± 0.5 %  
 Sensitivity : ± 0.5 % Accuracy (overall) : ± 2 %

**VALVE SIZING DATA:**

61. Medium : SH Steam  Sat. Steam   
 Water   
 62. Flow rate in T/Hr  
 63. Operating inlet pressure in Kg/cm<sup>2</sup> (a)  
 64. Operating inlet temperature in °C  
 65. Outlet pressure in Kg/cm<sup>2</sup> (a)  
 66. Viscosity : --  
 67. Operating (required) Cv  
 68. Operating noise level at 1.0 metre from valve surface  
 69. Outlet velocity

CONDITION				
1	2	3	4	5
REFER DRAWING No. 4-00-306-40726 FOR VALVE SIZING DATA				
REFER STANDARD TABLE				
<85	dba	(for all conditions)		

28.05.15	E.KRITHIGA	C.SARAVANAN	R.PRABA	DRG. NO:	REV
DATE	PREPARED	APPD	APPD/C&I	4-00-306-40728	00

**DESIGN DATA:**

70. Design Pressure Kg/cm<sup>2</sup>(g) : 42 Kg/Cm<sup>2</sup> (g)
71. Design Temperature °C : 100 °C
72. Rated/Design/Selected Cv of valve : \*
73. Velocity restriction : \*
74. Operating lift restriction : 10 to 80 %<sup>§</sup>.
75. lift at various operating Conditions 1 TO 6 : \*
76. Down stream limitations : \*
77. Up stream limitations : \*
78. Increase in signal Air : To open the Valve

**TESTING/INSPECTION:** (AS PER M/S NTPC APPROVED QUALITY PLAN: )

79. Hydraulic test report : Yes  No
80. Radiography : Critical Parts :  Total   
Not required :
81. IBR test report : Req'd. :
82. Type test : Capacity Evolution by \*  
ISA S39.2/5 39.4 : Required
83. Valve functional test : Yes  No
- \* Type test to be done atleast for one no on this consignment.
84. Accessories functional : Yes  No   
Test :
85. Seat leakage test : Yes  No
86. Material test report : Yes  No
87. Customer Inspection :  
In process : Yes  No   
Final : Yes  No
88. Third Party inspection : Yes  No

**DOCUMENTATION:** (Required)

89. With bid. (3 sets)
- Catalogues : Yes  No
- Dimensional drawing : Yes  No
- All data sheets : Yes  No
- Recommendation / Limitation : Yes  No
- Confirmatory report : Yes  No
- Contrary report : Yes  No
- Deviation report : Yes  No
90. Quality plan : Yes  No
91. With equipment :
- Dimensional drawing : 15 Sets
- O & M\*\* : --do--
- Data Sheets : --do--
- Test certificate : 1 CD + 3 Sets
92. Valve sizing, actuator sizing, Cavitation check, noise level calculations required with bid(with formulae) : Yes  No
93. --

**SPARES:**

94. Commissioning spares : \*
95. Mandatory spares : As per specification
96. 2/3 Years maintenance spares : \*

**OTHERS:**

97. Bidders experience list : Required  Not required
98. Operational feed back of such valves supplied elsewhere : Required  Not required
99. Equipment guarantee : Required  Not required
100. System guarantee : Required  Not required
101. Service contract for 5 Years : - To quote seperately
102. Commissioning of the valves : Required  Not required

**NOTES:**

1. \* DENOTES BIDDER TO SPECIFY; 2.\*\*VIDEO MANUAL PREFERRED; 3. § AS PER TENDER SPECIFICATION
4. # AFTER INSPECTION, SMART POSITIONER TO BE PACKED SEPARATELY ALONG WITH THE CONTROL VALVE AND MOUNTING ACCESSORIES. THE SAME WILL BE OPENED AND INSTALLED ONLY DURING COMMISSIONING.

28.05.15	E.KRITHIGA	C.SARAVANAN	R.PRABA	DRG. NO:	4-00-306-40728	REV
DATE	PREPARED	APPD	APPD/C&I	44		00