

1X800 MW WANAKBORI TPS EXT. UNIT-8

VOLUME – IIB

**TECHNICAL SPECIFICATION
FOR
BUTTERFLY VALVES (STEAM SERVICE)**

SPECIFICATION NO. PE-TS-408-100-M016



**BHARAT HEAVY ELECTRICALS LIMITED, POWER SECTOR
PROJECT ENGINEERING MANAGEMENT
NOIDA, INDIA**

	TITLE:	SPECIFICATION NO. PE-SS-999-100-Q001	
	PREAMBLE	VOLUME	
		SECTION	
		REV. NO.	DATE: 26/08/2011
		SHEET	1 OF 1

1.0 The tender document contains three (3) volumes. The bidder shall meet the requirements of all the three volumes.

1.1 **Volume-I (CONDITIONS OF CONTRACT)**

This consists of four parts as below:-

- Volume-IA : This part contains instructions to bidders for making bids to BHEL.
- Volume-IB : This part contains general commercial conditions of the tender & includes provision that vendor is responsible for the quality of item supplied by their sub-vendors.
- Volume-IC : This part contains special conditions of contract.
- Volume-ID : This part contains commercial conditions for erection & commissioning site work, as applicable.

1.2 **Volume-II TECHNICAL SPECIFICATIONS**

Technical requirements are stipulated in Volume-II which comprises of :-

- Volume-IIA : General Technical Conditions
- Volume-IIB : Technical Specification including Drawings, if any.

1.2.1 **Volume-IIB**

This volume is sub-divided into following sections:-

- Section-A : This section outlines the scope of enquiry.
- Section-B : This section provides "Project Information".
- Section-C : This section indicates technical requirements specific to the contract, not covered in Section-D.
- Section-D : This section comprises of technical specifications of equipments complete with data sheet A, B and C.

Data Sheet - A Specifies data and other requirements pertaining to the Equipment.

Data Sheet - B Specifies data to be filled by the bidder (Data Sheet-B is contained in Volume-III).

Data Sheet -C Indicates data/documents to be furnished after the award of contract as per agreed schedule by the vendor (as applicable).

1.2.2 **Volume-III (TECHNICAL SCHEDULES)**

This volume contains technical schedules and Data Sheets-B, which are to be duly filled by the bidder and the same shall be furnished with the technical bid.

2.0 The requirements mentioned in Section-C / Data Sheets-A of section-D shall prevail and govern in case of conflict between the same and the corresponding requirements mentioned in the descriptive portion in Section-D

	TECHNICAL SPECIFICATION BUTTERFLY VALVES (STEAM SERVICE) 1X800 MW WANAKBORI TPS EXT. UNIT-8	SPECIFICATION NO. PE-TS-408-100-M016	
		VOLUME : IIB	
		SECTION:	
		REV. NO.: 00	DATE: 25.09.2015
		SHEET 1	OF 1

CONTENTS

SECTION	TITLE
A	SCOPE OF ENQUIRY
B	PROJECT INFORMATION
C	SPECIFIC TECHNICAL REQUIREMENTS
D	STANDARD TECHNICAL SPECIFICATIONS
D1	VALVES <ul style="list-style-type: none"> ▪ STANDARD TECHNICAL SPECIFICATION FOR BUTTERFLY VALVES (STEAM SERVICE) ▪ DATA SHEET – A1 ▪ QUALITY PLAN
D2	ACTUATORS <ul style="list-style-type: none"> ▪ DATA SHEET – A2 ▪ WIRING DIAGRAM
	DATA SHEET – C

	TECHNICAL SPECIFICATION BUTTERFLY VALVES (STEAM SERVICE)	SPECIFICATION NO. PE-TS-408-100-M016	
		VOLUME : IIB	
		SECTION: A	
		REV. NO.: 00	DATE: 25.09.2015
		SHEET 1	OF 1

SECTION-A

SCOPE OF ENQUIRY

	TECHNICAL SPECIFICATION BUTTERFLY VALVES (STEAM SERVICE) 1X800 MW WANAKBORI TPS EXT. UNIT-8	SPECIFICATION NO. PE-TS-408-100-M016	
		VOLUME : IIB	
		SECTION: A	
		REV. NO.: 00	DATE: 25.09.2015
		SHEET 1	OF 1

SCOPE OF ENQUIRY

1. SCOPE

This enquiry covers the Design, Manufacture, Inspection & Testing at vendor's and/or his sub-vendor's works, proper packing and delivery to site of Butterfly Valves(steam service) complete with all accessories as per the requirements mentioned in different sections of the specification for 1X800 MW WANAKBORI TPS EXT. UNIT-8.

2. GENERAL TECHNICAL INSTRUCTIONS

- a) It is not the intent to specify herein all the details of design and manufacture. However the equipment shall conform in all respects to high standards of design, engineering and workmanship, and shall be capable of performing the required duties in a manner acceptable to Engineer/ Owner, who will interpret the meaning of drawing and specifications, and shall be entitled to reject any component or material, which in his judgement is not in full accordance herewith.
- b) The omission of specific reference to any component/ accessories necessary for the proper performance of Butterfly Valves (steam service) shall not relieve the bidder of the responsibility of providing such facilities to complete the supply of Butterfly Valves (steam service) at quoted prices.
- c) Design/ drawings/ data sheets etc. shall be subject to approval of BHEL as per specification, in the event of order.
- d) BHEL's / customer's representative shall be given access to the shop in which the equipment are being manufactured or tested and all test records shall be made available to him.
- e) The equipment covered under this specification shall not be despatched unless the same have been finally inspected, accepted and shipping release issued by BHEL.

	TECHNICAL SPECIFICATION BUTTERFLY VALVES (STEAM SERVICE)	SPECIFICATION NO. PE-TS-408-100-M016	
		VOLUME : IIB	
		SECTION: B	
		REV. NO.: 00	DATE: 25.09.2015
		SHEET	1 OF 1

SECTION-B

PROJECT INFORMATION

	TECHNICAL SPECIFICATION BUTTERFLY VALVES (STEAM SERVICE) 1X800 MW WANAKBORI TPS EXT. UNIT-8	SPECIFICATION NO. PE-TS-408-100-M016	
		VOLUME : IIB	
		SECTION: B	
		REV. NO.: 00	DATE: 25.09.2015
		SHEET 1 OF 1	

PROJECT INFORMATION

The bidder shall acquaint himself by a visit to the site, if felt necessary, with the Conditions prevailing at site before submission of the bid. The information provided in this section will be for general guidance and shall not be contractually bidding on BHEL/OWNER. All relevant site data/information as may be necessary shall have to be obtained /collected by the bidder.

Project information mentioned below:

INTRODUCTION

The proposed 1x800 MW Supercritical Thermal Power Project would be set up by Gujarat State Electricity Corporation Limited (GSECL) at Kheda district of Gujarat. The proposed extension unit will be developed in the existing Wanakbori Thermal Power Station and will be located north east side of the existing plot in the Kheda District of Gujarat. The Bidder shall acquaint himself by a visit to the site, if felt necessary, with the conditions prevailing at site before submission of the bid. The information given here in under is for general guidance and shall not be contractually binding on the Owner. All relevant site data /information as may be necessary shall have to be obtained /collected by the Bidder.

APPROACH TO SITE

The proposed site is located in Kheda district about 13 kilometres from the nearest commercial town of Balasinor & 10 kilometres from Sevalia town. The National Highway, NH-08, connecting Dakor – Godhra is about 10 kilometres from the site. The State Highway SH – 59 connecting Balasinor –Sevalia is about 2 Kilometres from the site. Nearest railway station to the existing site is Sevalia, located about 8 kilometres from the site on Anand –Godhara main broad gauge line of Western Railway. Nearby Air Ports are Ahmedabad at a distance of about 110 kilometres from the site and Vadodara at a distance of about 85 kilometres from the site.

	TECHNICAL SPECIFICATION BUTTERFLY VALVES (STEAM SERVICE)	SPECIFICATION NO. PE-TS-408-100-M016	
		VOLUME : IIB	
		SECTION: C	
		REV. NO.: 00	DATE: 25.09.2015
		SHEET	1 OF 1

SECTION-C

SPECIFIC TECHNICAL REQUIREMENTS

	SPECIFIC TECHNICAL REQUIREMENTS BUTTERFLY VALVES (STEAM SERVICE) 1X800 MW WANAKBORI TPS EXT. UNIT-8	SPECIFICATION NO. PE-TS-408-100-M016	
		SECTION C	
		REV. NO.: 00	DATE: 25.09.2015
		Sheet 1 of 2	

1. GENERAL

- 1.1 The valves shall meet the technical requirements and conform to the standard technical specifications, Data sheet A-1 & Data sheet-A2 of Section D. In addition, the requirements of this Section-C shall also be complied with. However, wherever the details given in standard technical specification of Section-D and Data sheets A-1 & A2 are different, the requirements of Data sheet A-1 & A2 shall prevail. Similarly in the event of contradictions between Section –C & Section –D/ Data sheet A-1 & A2, Section –C will prevail.
- 1.2 The technical requirements for valves shall, in general, be as per the attached standard Technical specification for Valves, and Data sheets A-1 and A-2 of Vol. II B Section D.

2. SCOPE OF SUPPLY

- 2.1 The valves complete with all accessories shall be supplied as per Data sheets A-1 & Data sheet-A2 of Section D. For detail refer the same. Each valve (quantity and other details specified in Data Sheet-A-1) shall be complete with the following accessories.
- i) Lifting arrangement provision for handling i.e., lifting lugs, eye bolts etc.
ii) Actuators and limit switches as required to make valve complete in all respects.
- 2.2 Commissioning spares.
2.3 Set of special tools and tackles if required for the maintenance, erection etc. of the equipment supplied.
2.4 Mandatory spares as per Datasheet-A1.
2.5 Finish paints for touch-up painting of equipment after erection at site in sealed containers.
2.6 Various drawings, datasheets, operation and maintenance manuals etc., as specified in Data Sheet-C.

3 EXCLUSIONS:

Erection & Commissioning of valve at site.

4 QUALITY ASSURANCE

The Quality Plans enclosed with this specification specify minimum quality control requirement. During contract stage vendor shall furnish these Quality Plans duly signed & stamped for their compliance. Quality plans shall be approved by BHEL and customer (If necessary). All inspection and testing shall be carried out by BHEL and CUSTOMER (if necessary). In case inspection is by both BHEL and CUSTOMER, then the inspection can be carried out jointly or separately, which will be informed later.

	SPECIFIC TECHNICAL REQUIREMENTS BUTTERFLY VALVES (STEAM SERVICE) 1X800 MW WANAKBORI TPS EXT. UNIT-8	SPECIFICATION NO. PE-TS-408-100-M016	
		SECTION C	
		REV. NO.: 00	DATE: 25.09.2015
		Sheet 2 of 2	

5 PAINTING REQUIREMENT:

Surface preparation shall be as per SSPC-SP-3/ Power Tool Cleaning followed by 2 coat of Heat Resistance Aluminium paint to IS 13183 Gr. I or equivalent, paint shade Aluminium and total DFT of paint will be equal to 120 microns minimum. The paint shade for the actuator will be informed after during drawing approval.

6 PACKING INSTRUCTIONS:

- a) Each valve shall be drained, cleaned, prepared and suitably protected in such a way so as to minimize the possibility of damage and deterioration during transit and storage.
- b) The valve has to be dispatched in total assembled form.
- c) Discs of all valves shall be properly secured while dispatching so that there is no risk of damage to the disc & seat.
- d) Body ends shall be suitably sealed to protect them against damage during transit and storage.
- e) Valves with butt-welding ends shall be protected by means of polythene caps/rubber and protectors to prevent damage to ends & also to avoid foreign material entering the valve while shipment & storage.
- f) Valve Tag Nos. shall be incorporated in all the dispatch documents.
- g) Proper care shall be taken to avoid damage to the painted surface during transit.
- h) All the valves shall be packed suitably in wooden cases in order to avoid damage during transit and also during storage at site in tropical climate conditions for a period of 15-18 months.

7 SPARES

- a) **Mandatory Spares:** These shall be as per Data Sheet-A1.
- b) Order for the spares may be placed simultaneously or otherwise at the option of purchaser.

8 DOCUMENTS TO BE SUBMITTED ALONG WITH OFFER

Bidder shall submit the following documents (enclosed in Vol III) duly filled, signed and stamped along with the bid:

- a) Compliance sheet
- b) Schedule of Deviations if any.
- c) Schedules of Price & Unit Price for each project.
- d) Schedule of declaration.

The above are the only documents which will be used for technical evaluation unless other documents are asked for during technical clarifications. Any other technical document enclosed with the bid shall be ignored for the purpose of technical evaluation. All other documents attached with the specification are for information of the vendor and no comments shall be marked on these.

	TECHNICAL SPECIFICATION BUTTERFLY VALVES (STEAM SERVICE)	SPECIFICATION NO. PE-TS-408-100-M016	
		VOLUME : IIB	
		SECTION: D	
		REV. NO.: 00	DATE: 25.09.2015
		SHEET 1	OF 1

SECTION-D

STANDARD TECHNICAL SPECIFICATIONS

D1: FOR VALVES

D2: FOR ACTUATORS

DATA SHEET – C

	TECHNICAL SPECIFICATION BUTTERFLY VALVES (STEAM SERVICE)	SPECIFICATION NO. PE-TS-408-100-M016	
		VOLUME : IIB	
		SECTION: D	
		REV. NO.: 00	DATE: 25.09.2015
		SHEET	1 OF 1

SECTION-D1

VALVES

STANDARD TECHNICAL SPECIFICATION QUALITY PLAN DATA SHEET – A1



TITLE:
**STANDARD TECHNICAL SPECIFICATION
FOR BUTTERFLY VALVES
(STEAM SERVICE)**

SPECIFICATION NO. PE-SS-999-100-M016
VOLUME. II B
SECTION D
REV. NO. 04 DATE. 02.08.2013
SHEET 1 OF 5

1.0 GENERAL

This specification covers the design, materials, construction features, manufacture and testing comprising of Butterfly valves (steam service) at Vendor's or/ and sub-Vendor's works inclusive of painting and packing requirements.

2.0 CODES AND STANDARDS:

The design, manufacture, inspection and testing of the butterfly valves shall suit the design parameters specified in datasheet-A1 & comply with the requirements of latest revisions of the following standards. However, the testing shall be as per American Water Works Association AWWA C504-10 and C516-10 (whichever is applicable) including disc strength test (all sizes of valves), gear box POD Test & Valve POD test.

- a) AWWA C504-10 upto size 1800 mm.
- b) AWWA C516-10 upto for size 2000 mm and above.

2.1 In case of any conflict between the above Codes/Standards and this specification, the later shall prevail and in case any further conflict in this matter, the interpretation of the specification by the BHEL engineer shall be final & binding.

3.0 DESIGN REQUIREMENTS:

3.1 All valves shall be suitable for the service conditions i.e. flow, temperature and pressure under which they are required to operate and those performing similar duties shall be interchangeable with each other unless otherwise specified.

3.2 The butterfly valves shall be suitable for Indoor/outdoor installation with shaft either in horizontal or vertical position.

3.3 The valves shall have double off-set type disc (design with shaft eccentric to disc) long body design for AWWA C504-10 or maximum laying length for AWWA C516-10 as specified in Data sheet-A1.

3.4 The butterfly valves shall be with butt welded ends as specified in Data sheet-A1 and designed to ensure bubble tight shut off at the rated pressure of valve.

3.5 MATERIALS

3.5.1 The materials of construction of main parts of the butterfly valves (steam service) shall be specified in Data sheet-A1.

3.5.2 The materials of construction of the remaining parts shall be as per relevant standard governing the valves and to suit the service conditions. These materials shall be subject to approval of the purchaser.

3.5.3 Materials used in manufacture of valves shall be of tested quality.

4.0 CONSTRUCTION FEATURES:

4.1 Valve Body

4.1.1 The valve body shall have integral hubs for shaft bearing housing. The minimum body shell thickness and minimum diameter of seat bore shall be as per requirement of the applicable table/equation of AWWA-C504-10/C516-10 (whichever is applicable). Material of construction of body and valve parts shall be as per materials indicated in Data sheet-A1.



TITLE:
**STANDARD TECHNICAL SPECIFICATION
FOR BUTTERFLY VALVES
(STEAM SERVICE)**

SPECIFICATION NO. PE-SS-999-100-M016

VOLUME. II B

SECTION D

REV. NO. 04

DATE. 02.08.2013

SHEET 2 OF 5

4.1.2 An arrow shall be embossed/ engraved and painted on the outside of body to clearly indicate the direction of flow.

4.2 Valve Shaft

4.2.1 The shaft of each butterfly valve shall be securely attached to the disc through Bolting, Riveting, threading, upsetting or cross pinning, adequately locked.

4.2.2 Valve shaft design shall consist of one piece unit extending completely through the valve disc. or may be the "Stub Shaft" type which consists of two separate shafts inserted into the disc. Each stub shaft shall be inserted into the valve disc hubs for a minimum distance of at least 1.5 times shaft diameter. The connection between the shaft and the disc shall be designed to transmit shaft torque equivalent to at least 75% of the torsional strength of the minimum required shaft diameter. The minimum shaft diameter shall be as per the relevant standard and shall be such that it will safely sustain the maximum differential pressure across the closed valve and transmit the maximum torque required to operate the valve.

4.2.3 Surface finish for shaft shall be minimum 16 RMS in the area of gland packing.

4.3 Valve Disc:

The valve disc shall have no external ribs transverse to the flow and shall sustain full differential pressure across closed valve disc without exceeding working stress of one fifth of the tensile strength of the material used. The thickness of the valve disc shall not be more than $2 \frac{1}{4}$ times the shaft diameter listed in AWWA-C504-10/C516-10 (whichever is applicable). The valve disc shall be designed to rotate 90° from full open to tight shut off position. Material of Disc shall be as per the Data sheet-A1.

4.4 Body Seat & Disc Seal (Valve seat)

The soft seat shall be of replaceable type of suitable grade resilient material, adequately reinforced, securely attached to the disc or to the body, and shall be designed to provide bubble tight shut off under all operating conditions. The soft seat/ seal shall be attached by clamping ring, bolting or other suitable methods as per the standard design of the manufacturer. All clamping rings, bolts/studs, nuts used shall be of stainless steel. The sealing ring on the disc shall be continuous type and easily replaceable. The mating seat surface accordingly shall be on valve body or disc and shall be of stainless steel and securely attached to the body/disc by directly clamping, bolting or suitable methods. All clamps, retaining rings, nuts, screws / all hardware shall be of stainless steel.

4.5 Valve Bearing:

Each butterfly valve shall be fitted with sleeve type bearings contained in the hub of the valve body. The bearing shall be of self-lubricating type and the coefficient of friction of bearing material shall not exceed 0.25 when rubbing at the maximum bearing pressure. The housing for this bearing shall be rigidly attached to the valve body. Thrust bearings shall also be provided for vertical shaft installation. For valves of 350 NB and larger, the bearing should be capable of taking axial thrust also. The material of the bearing shall be self-lubricated type & low coefficient of friction in accordance with the relevant standard.

4.6 Shaft Seal:

Wherever the shaft project through the valve body for actuator connection, a shaft seal shall be provided. Shaft seal shall be designed for use of Standard 'O' rings seals and they shall be contained in a removable corrosion resistant recess. Shaft seals shall be designed to allow its replacement without removal of the valve shaft.

4.7 The hand wheel shall be of malleable iron or equivalent.



TITLE:
**STANDARD TECHNICAL SPECIFICATION
FOR BUTTERFLY VALVES
(STEAM SERVICE)**

SPECIFICATION NO. PE-SS-999-100-M016

VOLUME. II B

SECTION D

REV. NO. 04

DATE. 02.08.2013

SHEET 3 OF 5

4.8 Body Ends:

These shall be as butt welded as per ASME B 16.25 as specified in Data sheet-A1.

4.9 Nameplate:

Each valve shall be fitted with a circular Stainless steel 2mm thick nameplate indicating the valve Tag No. and service description given in Data sheet-A1. All details shall be engraved 1 mm deep and filled with black enamel paint.

4.10 The stops which limit the travel of any valve in the 'Open' or 'Shut' position shall be arranged exterior to the valve body.

4.11 All valves shall be closed by rotating the handwheel in a clockwise direction when looking at the face of the handwheel. The pulling force required on handwheel rim shall not exceed 25 Kgf when operating the valve under full flow and operating pressure. The face of each hand wheel shall be clearly marked with the words 'Open' and 'Shut' with adjacent arrows to indicate the direction of rotation to which each refers.

4.12 Special attention shall be given to the operating mechanism for large size valves in order that quick and easy operation is obtained and maintenance is kept to a minimum.

4.13 Eyebolts shall be provided where necessary to facilitate handling heavy valves or part of valves.

4.14 Wherever practical, valves (including actuator, drive motor, integral bypass etc.) of total weight equal to or greater than 500 Kg shall be provided with suitable lugs to permit direct suspension by hanger rods or direct resting on bottom support, as applicable.

4.15 The valves as well as accessories shall be designed for easy dismantling and maintenance.

4.16 The disc shall rotate through 90° from full open to the tight shut position. The disc shall be contoured to ensure the least possible resistance to flow and be suitable for throttling operation. While the disc is in throttled position, the valve shall not create any noise or vibration.

4.17 It may be noted that all construction features design and parameters will be governed by AWWA-C504-10 for sizes upto 1800 mm and AWWA-C516-10 for sizes 2000 mm and above.

5.0 SPECIAL FEATURES:

5.1 Gland Sealing Arrangement:

Butterfly valves, provided with gland sealing arrangement, shall be vacuum tested. All valves required with this arrangement shall be provided with G3/8" connection (duly plugged) for water sealing. Sealing water shall be supplied at 4 ata and 50°C unless otherwise specifically indicated for the particular project.

5.2 Motorised Valves:

5.2.1 The motorised valves shall be offered with the electric actuators of reputed make. A particular make and type of actuator shall be designed for the maximum differential working pressure. However, the stall torque of the selected actuators shall be minimum 1.5 times the valve unseating torque requirement at the maximum differential



TITLE:
**STANDARD TECHNICAL SPECIFICATION
FOR BUTTERFLY VALVES
(STEAM SERVICE)**

SPECIFICATION NO. PE-SS-999-100-M016
VOLUME. II B
SECTION D
REV. NO. 04 DATE. 02.08.2013
SHEET 4 OF 5

working pressure (design pressure) and required operating time as mentioned in in Datasheet A-1/Datasheet A-2.

- 5.2.2 Electric actuators shall be mounted directly on the valves.
- 5.2.3 The motors, gearing and disengaging hand wheel shall be adequate to open and close the valve under maximum differential pressure and shall be completely assembled on the respective valve and shop tested before shipment.
- 5.2.4 Gear box and Electric Actuator shall also meet the inspection & testing requirements of latest revision of AWWA-C504-10 /AWWA C542-10 respectively.

6.0 INSPECTION AND TESTING:-

All inspection & Testing for valve, Gear box and actuators shall be as per the requirements of the relevant standard.

The minimum NDT/testing and inspection requirements for valve, Gear Box, electric actuator etc. shall be as per the attached Quality Plan. However, in case of order, final inspection and testing shall be carried out as per the final approved quality plan without any price implications.

6.1 P.O.D. Tests:

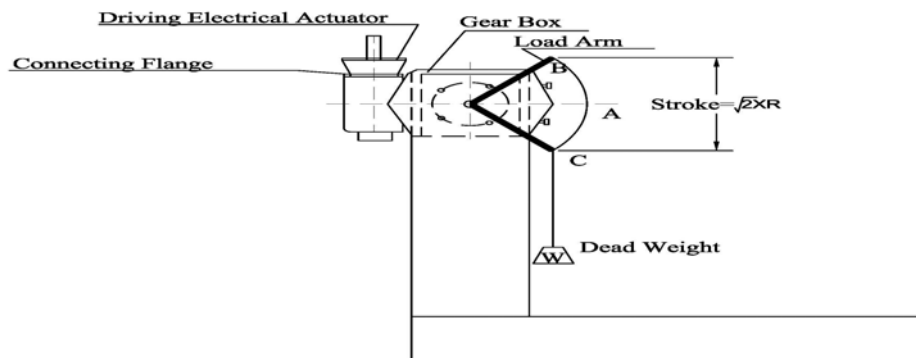

TEST SET UP

FIG. 1

- a) POD (Proof-of-design) Test as per AWWA-C504-10/C516-10 (whichever is applicable) is required to be carried out for valves. In case the valve POD Test has been done earlier, only Test Report of POD test for same model/ type/size/ rating is required to be submitted for verification.
- b) Gear Box and Electric Actuator shall be designed & tested in accordance with latest editions of AWWA C 504-10(gearbox) and AWWA C 542-10 (actuator) respectively. Gear Box shall be designed to hold the valve disc in intermediate position between full open and full closed position without creeping or fluttering.
- c) For valves designed and manufactured as per AWWA POD shall follow the guidelines of AWWA-C504-10/C516-10 (whichever is applicable) and Actuators shall meet the requirements of POD test of AWWA-C-542-10.
- d) Gear box POD test: - Valve POD and gear box POD tests should be done separately on each one of the valve & the gear box. Gear box POD test shall be done as per the procedure described below or as per the procedure agreed between purchaser & vendor.



TITLE:
**STANDARD TECHNICAL SPECIFICATION
FOR BUTTERFLY VALVES
(STEAM SERVICE)**

SPECIFICATION NO. PE-SS-999-100-M016	
VOLUME. II B	
SECTION D	
REV. NO. 04	DATE. 02.08.2013
SHEET 5 OF 5	

e) Gear box POD Test shall be carried out only at full rated torque of gear box, throughout the full cycle of testing i.e. at no point during each full cycle of testing; the applied torque should be less than the full rated torque of Gear Box. Refer Sketch for Gear Box POD test set up. Dead weight and length of arm shall be so selected that the torque generated at point "C" and "B" shall in no case be less than the full rated torque of the gear box. (refer fig.1)

f) Irrespective of the requirement of conducting the type tests, the vendor shall submit the reports of the type tests carried out within last five years from the date of bid opening. These reports should be for the tests conducted on the equipment same (model / type/ size / rating) to those proposed to be supplied. Tests should have been conducted at an independent laboratory or should have been witnessed by a client.

6.2 These valves are for vacuum service and shall be provided with gland sealing arrangement which shall be vacuum tested with vacuum and helium gas.

7.0 PERFORMANCE GUARANTEE:

7.1 The vendor shall guarantee the material & workmanship of all components as well as operation of the equipment as per the requirements of the specification.

7.2 The vendor shall also guarantee the following for each butterfly valve:

- a) Pressure drop as per the approved drop vs. opening curve.
- b) The valve opening and closing time.

8.0 SURFACE PREPARATION & PAINTING

The surface preparation of all exterior and interior surfaces of valves shall include the following:

- a) Removal of oil, grease and dirt.
- b) Removal of rust and scale etc.
- c) Sand blasting/ shot blasting.

All exterior surfaces of valves shall be painted with primer and finish coated with coating of min. 80 microns thickness. Color shade etc. shall be subject to BHEL/ Customer approval.

9.0 CLEANING AND PROTECTION FOR DESPATCH:

9.1 Each valve shall be drained, cleaned, prepared and suitably protected in such a way so as to minimize the possibility of damage and deterioration during transit and storage.

9.2 Discs of all valves shall be unseated when they are despatched but care shall be taken to ensure that there is no risk of damage to the disc.

9.3 Body ends shall be suitably sealed to protect them against damage during transit and storage.

9.4 Valve Tag Nos. shall be incorporated in all the despatch documents.



**DATA SHEET- A1
BUTTERFLY VALVE (STEAM SERVICE)
1X800 MW WANAKBORI TPS EXT. UNIT-8**

SPECIFICATION NO. PE-TS-408-100-M016

VOLUME - IIB

SECTION: D

REV. NO.: 00

DATE: 25.09.2015

SHEET 1 OF 4

1	2	3	4	5	6		7	8	9	11	12	13		14	15	16	17	18									
					DESIGN	SERVICE						MATCHING PIPE OD X THKN						COMMISSIONING SPARES				MANDATORY SPARES COMPLETE VALVE ASSEMBLY WITH ACTUATOR WITHOUT COST OF COMMISSIONING SPARES					
SL NO.	TAG NOS.	TYPE OF VALVE	SIZE mm (NB)	OPERATION			PRESSURE KG/CM2(G)	TEMP (DEG °C)	RATING, DESIGN & TESTING CODE	BODY & DISC MATERIAL	END CONN	SPECIAL FEATURES	MM	MM	MAIN VALVES QTY WITHOUT COMMISSIONING SPARES NOS.	GLAND PACKING (VALVES) (SETS)	BOTTOM GASKET (VALVES) (SETS)	O' RING AND SEALS FOR ELECTRIC ACTUATOR S(SETS)	DISC SEAL (SETS)	COMPLETE VALVE ASSEMBLY WITH ACTUATOR & GEAR BOX WITHOUT COMMISSIONING SPARES (As per Sno. IV (3.1)) (No.)	COMPLETE ACTUATOR (As per Sno. 13.1) (No.)	LIMIT SWITCH (As per Sno. 13.2) (No.)	TORQUE SWITCH (As per Sno. 13.3) (No.)	AUXILIARY CONTACT (As per Sno. 13.4) (No.)	COMPLETE MOTOR USED IN ACTUATOR (As per Sno. 13.5) (No.)	COMPLETE SEAL KIT (As per Sno. 13.6) (SETS)	COMPLETE O' RING SET (As per Sno. 13.7) (SETS)
1	EXV-31, EXV-32 (1 EACH)	BUTTERFLY VALVE (STEAM SERVICE)	2000	MO	Full vacuum and 2 kg/cm2	100	BFP DRIVE TURBINE EXHAUST LINE	CL.75B (MINIMUM) OF AWWA C516- 2010	CCS (ASTM A216 GR. WCB)	BW AS PER ASME B16.25	SG, MO, OT = 50 - 90 SEC, SHAFT AXIS ORIENTATION HORIZONTAL/ VERTICAL SUITABLE FOR BOTH DIRECTIONS; ELECTRIC ACTUATOR WITHOUT INTEGRAL STARTER.	2032	16	2	2	2	2	2	1	1	2	2	1	1	1	1	

ABBREVIATIONS:-
 BW- BUTT WELDED, CCS - CAST CARBON STEEL, SG - SEALED GLAND, MO - MOTORISED ELECTRIC ACTUATOR OT - OPENING/CLOSING TIME OF VALVE WITH ELECTRIC ACTUATOR OPERATION
 1. Valve POD , Gear box POD & Actuator POD test, if already carried out by bidder for similar model/ type/ size/ rating for any BHEL/NTPC/REPUTED CUSTOMER project within the last 5 years from the date of bid opening of this project, i.e. 21-Oct-2014, shall be considered applicable for this project, if found satisfactory by BHEL & NTPC.
 2. Valve POD, Gear box POD & Actuator POD test, if required, as per technical specification & AWWA C516, then the charges for the same shall deemed to be included in the unit quoted prices of main valves. Bidder shall not indicate these charges as a separate head in the price bids.
 3. Main valve prices shall BE EXCLUSIVE of cost of Commissioning Spares prices.
 4. Bidder is required to quote unit price of each item under commissioning spares separately & individually i.e. prices of all commissioning spares shall not be clubbed/ included in the unit price of Main valves.
 5. Commissioning spares --> One set each of Bottom/ Cover Gasket with O' Rings & Seals, Gland Packing with 'O' ring & seals in Gland packing area and actuator "o" rings and seal as applicable.
 6. All the mandatory spares are to be quoted individually & separately.

Signature of the bidder with name, designation, date and company's seal

	DATA SHEET-A1 BUTTERFLY VALVES (STEAM SERVICE) 1X800 MW WANAKBORI TPS EXT. UNIT-8	SPECIFICATION NO. PE-TS-408-100-M016	
		VOLUME-IIB	
		SECTION : D	
		REV. NO.: 00	DATE: 25.09.2015
		Sheet Page 2 of 4	

Material of Construction

SL NO.	PART NAME	MATERIALS
VALVE		
a.	Valve Body Butt welded: (Long body butt weld ends)	ASTM A-216 Gr. WCB
b.	Valve Disc.	ASTM A-216 Gr.WCB
c.	Shaft	ASTM A182 Gr..F304
d.	Disc Seal/Seat	EPDM (70 ~ 75 SHORE 'A')
e.	Valve body seat edge	AISI 316 (WELD OVERLAY/ DEPOSIT)
f.	Seat retaining ring and internal Bolts etc.	SS 304/316
g.	Bearing	SLEEVE TYPE, SELF LUBRICATED
h.	Shaft seal :	'O' RINGS TYPE (65~70 SHORE 'A')
i.	Fasteners (bolts & nuts)	ASTM A193 Gr. B7 (BOLTS) / ASTM A194 Gr. 2H(NUTS)
j.	Hand wheel (actuator)	MALLEABLE IRON (NO OTHER ALTERNATE MATERIAL ACCEPTABLE)
GEAR BOX. (Bevel type)		
k.	Main Housing /Cover (Totally enclosed construction)	Cast Iron IS:210 Gr. FG 220/260
l.	Input shaft	13/% Cr SS/ EN8 (~200 BN)
m.	Worm	EN8 (~200 BN)
n.	Worm Wheel	Ductile iron / S.G iron
o.	Hand wheel	Malleable Iron

	DATA SHEET-A1 BUTTERFLY VALVES (STEAM SERVICE) 1X800 MW WANAKBORI TPS EXT. UNIT-8	SPECIFICATION NO. PE-TS-408-100-M016	
		VOLUME-IIB	
		SECTION : D	
		REV. NO.: 00	DATE: 25.09.2015
		Sheet Page 3 of 4	

TECHNICAL REQUIREMENTS

1. Tag no. : EXV-31 & EXV-32
2. Quantity : One each (total 2 nos.) per unit
3. Total Qty. : total 2 nos
4. Type : Resilient seal.
5. Service : Butterfly valves shall be located in the exhaust ducts of the auxiliary drive turbines of the boiler feed pumps to isolate the aux. drive turbine from the surface condenser.
6. Size (Nominal) mm : 2000
7. Flow medium : Wet Steam, 2-7% moisture
8. Flow Velocity (Design) : 100 m/sec
9. Operating parameters : At normal condition At maximum condition
 - 9.1 Pressure (kg/cm² (a)) : 0.0836 0.0871
 - 9.2 Flow (T/hr) : 59.481 67.069
 - 9.3 Dryness fraction : 0.94 0.938

	DATA SHEET-A1 BUTTERFLY VALVES (STEAM SERVICE) 1X800 MW WANAKBORI TPS EXT. UNIT-8	SPECIFICATION NO. PE-TS-408-100-M016	
		VOLUME-IIB	
		SECTION : D	
		REV. NO.: 00	DATE: 25.09.2015
		Sheet Page 4 of 4	

TECHNICAL DATA

1. Design Pressure : Full vacuum and 2 kg/cm² (g)
2. Design temp. : 100 Deg. C
3. End Connections : Butt welded
4. Connecting pipe size and material : OD 2032 x 16 thk.
SA672 Gr. B60 Cl.12/22
5. Valve operation type : Motor operated
6. Shaft Axis orientation : Horizontal
7. Pipe line axis orientation : Horizontal
8. Operation : Full open & full close
9. Design pressure drop at max. flow.: 0.0002 kg/cm² (max.)
10. Valve rating : Class 75 B (minimum) of AWWA C516/10



QUALITY PLAN

CUSTOMER: M/S GSECL
VENDOR: LATER

PROJECT: 1X800 MW WANAKBORI TPS EXT. UNIT-8
REV.00 dtd. 25-09-2015
QP NO.: PE-QP-408-100-M016

SPEC NO.: PE-TS-408-100-M016

SPEC. TITLE STANDARD SPEC. FOR TWO WAY
BF VALVE FOR STEAM SERVICE

SECTION - VOLUME

SHEET 2 OF 8

SYSTEM STEAM SERVICE

ITEM: CAST CARBON STEEL BUTTERFLY VALVE
UPTO SIZE 2000 NB MOTORIZED

S.N O.	COMPONENT/ OPERATION	CHARACTERISTICS CHECKED	CAT E-GO RY	TYPE/METH- OD OF CHECK	EXTENT OF CHECK	REFERENCE DOCUMENT	ACCEPTANCE NORMS	FORMAT OF RECORD	AGENCY	REMARKS
									P W V	

1.3	DISC SEAL (FROM VENDOR'S REGULAR & APPROVED SOURCE)	1. VISUAL INSPN	MA	VISUAL	100%	APPD DRG	APPD DRG	INSPN REPORT	3/2	2	1	
		2. DIMENSIONS	MA	MEASURE- MENT	100%	APPD DRG	APPD DRG	LOG BOOK	3/2	2	1	
		3. TENSILE AND HARDNESS FOR VULCANISING	MA	MEASUREM ENT	100%	APPD DRG	APPD DRG	TEST CERT	3/2	2	1	
		4. OZONE CRACK RESISTANCE	MA	TESTING	1/BATCH	TECH. SPEC + ASTM D1149	TECH. SPEC + ASTM D1149* AWWA C 504	TEST CERT.	3/2	2	1	SPECIMEN TYPE A, 40 DEG CENTIGRADE FOR 70 HRS
		5. ELONGATION	MA	TESTING	1/BATCH	IS-3400 PART-I	250% MIN	TEST CERT	3/2	2	1	
		6. BLEED RESISTANCE	MA	TESTING	1/BATCH	SAMPLE TO BE KEPT IN 33% HCL. DM WATER, 48% NaOH FOR 72 HRS.	NO DISCOLO- URATION. WEIGHT GAIN +/- 0 TO 2%	TEST CERT	3/2	2	1	
		7. AGEING TEST	MA	TESTING	1/BATCH	TECH. SPEC + IS 3400 PART IV	TECH. SPEC + IS3400 PART IV *	TEST CERT	3/2	2	1	*-TEST TEMP. 125 DEG C, TEST DURATION 72 HRS, MAX CHANGE IN TENSILE STRENGTH. 20% ELOGATION: 20%, HARDNESS:3%
		8. HYDRAULIC STABILITY TEST (AFTER AGEING)	MA	TESTING	1/BATCH	TECH SPEC./ REL STD.	TECH SPEC./ REL STD.	TEST CERT	3/2	2	1	
		9. WEAR RESISTANCE	MA	TESTING	TYPE TEST	AWWA C-504/C516	NO DAMAGE	TEST REPORT	3/2	2	1	TYPE TEST REPORT WILL BE FURNISHED FOR REVIEW
1.4	FASTENERS ASTM 193 GR B7, ASTM 194 GR2H, GRB8M	1. VERIFICATION OF MAKE, GRADE, REVIEW OF TEST CERTIFICATE	MI	VISUAL	100%	TECH. SPEC/ DATA SHEET	TECH. SPEC/ DATA SHEET	INSPN REPORT	3/2	2	1	
		2. DIMENSIONS	MA	MEASURE- MENT	SAMPL- ING PLAN	APPD DRG	APPD DRG	INSP REPORT	2	2	1	

BHEL		BIDDER/VENDOR	
	PARTICULARS		
	NAME		
	SIGNATURE		
	DATE		
		BIDDER'S/ VENDOR'S COMPANY SEAL	

Anuj Awasthi
Engineer, MPL



QUALITY PLAN

SHEET 4 OF 8

CUSTOMER: M/S GSECL
VENDOR: LATER

PROJECT: 1X800 MW WANAKBORI TPS EXT. UNIT-8
QP NO.: PE-QP-408-100-M016
REV.00 dtd. 25-09-2015

SPEC NO.: PE-TS-408-100-M016
SPEC. TITLE STANDARD SPEC. FOR TWO WAY
BF VALVE FOR STEAM SERVICE

SYSTEM: STEAM SERVICE
ITEM: CAST CARBON STEEL BUTTERFLY VALVE
UPTO SIZE 2000 NB MOTORISED

SECTION - VOLUME

S.N O.	COMPONENT/ OPERATION	CHARACTERISTICS CHECKED	CAT E-GO RY	TYPE/METH- OD OF CHECK	EXTENT OF CHECK	REFERENCE DOCUMENT	ACCEPTANCE NORMS	FORMAT OF RECORD	AGENCY	REMARKS
									P W V	

2.	TRAVEL/STROKE		MA	}}							
3.	TRAVEL TIME		MA	}}							
4.	OPERATION OF LIMIT SWITCH		MA	}}							
5.	MANUAL OPERATION THROUGH HAND WHEEL		MA	}}							
6.	OPERATION TEST WITH POWER SUPPLY VARIATION ENERGISES TO OPEN/CLOSE		MA	}}							
7.	IR.HV,IR		MA	}}							
8.	DEGREE OF PROTECTION		MA	}}	1/TYPE	TECH. SPEC./ APPD. DRG./ DATA SHEET/ IS:9334	TECH. SPEC./ APPD. DRG./ DATA SHEET/ IS:9334	3 RD PARTY TEST CERT.	3	-	1
9.	DESIGN VERIFICATION		MA	}}	1/TYPE TEST (CYCLE TEST)	AWWA C504/C-516 & AWWA C542	AWWA C504/C-516 & AWWA C542	TEST CERT	3/2	2	1

2.0 INPROCESS CONTROL:-

2.1 BODY & DISC	1 DIMENSIONS	MA	MEASURE- MENT	100%	MFG DRG	MFG DRG	INSPN. REPORT	2	--	1
-----------------	--------------	----	---------------	------	---------	---------	---------------	---	----	---

BHEL		PARTICULARS		BIDDER/VENDOR	
		NAME			
		SIGNATURE			
		DATE			

ANUJ AWASTHI
Engineer, MPL

BIDDER'S/ VENDOR'S COMPANY SEAL



QUALITY PLAN

CUSTOMER: M/S GSECL
VENDOR: LATER

PROJECT: 1X800 MW WANAKBORI TPS EXT. UNIT-8
REV.00 dtd. 25-09-2015
QP NO.: PE-QP-408-100-M016

SPEC NO.: PE-TS-408-100-M016
SPEC. TITLE STANDARD SPEC. FOR TWO WAY
BF VALVE FOR STEAM SERVICE

SHEET 5 OF 8

SYSTEM STEAM SERVICE
ITEM: CAST CARBON STEEL BUTTERFLY VALVE
UPTO SIZE 2000 NB MOTORIZED

SECTION - VOLUME

S.N O.	COMPONENT/ OPERATION	CHARACTERISTICS CHECKED	CAT E-GO RY	TYPE/METH- OD OF CHECK	EXTENT OF CHECK	REFERENCE DOCUMENT	ACCEPTANCE NORMS	INSPN. REPORT	FORMAT OF RECORD	AGENCY	REMARKS
										P W V	

		2. SURFACE DEFECTS	CR	P.T.	100%	ASTM E165	ANSI B 16.34 APPENDIX III	INSPN. REPORT		2	1	ON MACHINED AREA ONLY.
2.2	WELDING OVERLAY DEPOSIT	WELDING PROCEDURE AND WELDER PERFORMANCE QUALIFICATION CLADDING	CR	VISUAL MECH. TESTS	100%	ASME IX	ASME IX	INSPN. REPORT		3/2	--	ONLY BHEL / CUSTOMER QUALIFIED WELDERS SHALL BE ENGAGED FOR WELDING. WPS SHALL BE SUBMITTED FOR APPROVAL.
			MA	DEPTH MEASUREMENT	100%	MFG. DWG	MFG. DWG	TEST REPORT		2	1	
			MA	SURFACE DEFECT LPI ON WELD OVERLAY AND ADJACENT AREA	100%	ASTM 165	FREE FROM POROSITY / CRACK	NDT REPORT		2	1	
2.2.1	SEAT RING	1. SUB-SURFACE DEFECTS	MA	RT/UT	100%	ASME B16.34	ASME B16.34	INSPN REPORT		3/2	2	
		2. SURFACE DEFECT	MA	LPI	100%	ASTM A165	FREE FROM CRACKS	INSPN REPORT		2	1	
2.3	BODY (BUTT WELD ENDS)	SUB-SURFACE DEFECT INTERNAL DEFECTS	CR	MPI	100% ON BW AREA	ASTM A709	ANSI B 16.34 APPENDIX III	NDT REPORT		2	1	
			CR	RT	100% ON BW AREA	ASME B16.34	ASME B16.34	RT REPORT				RT (100%) ON BW ENDS AS PER SL. NO. 1.1 CLAUSE NO.2
2.4	SHAFT	1. DIMENSION	MA	MEASURE- MENT	100%	MFG DRG	MFG DRG	LOG BOOK		2	--	
		2.SURFACE DEFECTS	MA	P.T.	100%	ASTME165.	ANSI B 16.34 APPENDIX III	INSPN REPORT		2	1	

BHEL		PARTICULARS		BIDDER/VENDOR	
		NAME			
		SIGNATURE			
		DATE			
		BIDDER'S/ VENDOR'S COMPANY SEAL			

Anuj Awasthi
Engineer, MPL



QUALITY PLAN

SHEET 6 OF 8

CUSTOMER: LATER
VENDOR: LATER

PROJECT : LATER
QP NO. . PE-QP-392-100-M024

REV. 00 DT. 07-04-14

SPEC. NO : PE-MOU-999-100-M016
SPEC. TITLE STANDARD SPEC. FOR TWO WAY
BF VALVE FOR STEAM SERVICE

SYSTEM STEAM SERVICE
ITEM: CAST CARBON STEEL BUTTERFLY VALVE
UPTO SIZE 2000 NB MOTORIZED

SECTION - VOLUME

S.N O.	COMPONENT/ OPERATION	CHARACTERISTICS CHECKED	CAT E- GO RY	TYPE/METH- OD OF CHECK	EXTENT OF CHECK	REFERENCE DOCUMENT	ACCEPTANCE NORMS	FORMAT OF RECORD	AGENCY	REMARKS
									P W V	

3.1	VERIFICATION OF ALL PREVIOUS TESTS AND DOCUMENTS	VERIFICATION OF RECORDS	MA	---	100%	TECH SPEC	TECH SPEC	---	2 1 1	
3.2	TESTS (HYDRAULIC)	1. BODY TEST	CR	HYDRO TEST	100%	AWWA C-504/C- 516/APPD DRG.	NO LEAKAGE	INSP. REPORT	2 1 --	
		2. DISC STRENGTH	CR	HYDRO TEST	100%	AWWA C-504/C- 516 APPD.DRG.	NO DEFORMATION/ NO STRUCTURAL DAMAGE TO DISC	INSP. REPORT	2 1 -	ONE VALVE/SIZE SHALL BE TESTED FOR TWICE THE DESIGN PRESSURE FROM BOTH SIDE OF THE VALVE IN ADDITION TO 100% TESTING IN THE NORMAL FLOW DIRECTION. NO PART OF DISC/ VALVE SHALL BE PERMANENTLY DEFORMED/ DAMAGED. DISC DEFORMATION IS MEASURED USING DIAL GAUGE AND BODY DEFORMATION BY MEASURING TAPE
		3. SEAT LEAKAGE WITH ACTUATOR (BOTH DIRECTION)	CR	HYDRO/AIR TEST	100%	AWWA C-504/C- 516/APPD. DRG.	NO LEAKAGE	INSP. REPORT	2 1 -	
		4. PERFORMANCE TEST	CR	PERFORM- ANCE	100%	AWWA C-504/C- 516*	SMOOTH OPERATION	INSP. REPORT	2 1 -	* COMPLETE VALVE ASSEMBLY ALONG WITH ACTUATOR SHALL BE SHOP OPERATED IN HORIZONTAL & VERTICAL POSITION 1) UNDER AT NO LOAD (25 CYCLES) 2) UNDER PRESSURE (CRACK OPEN 3 CYCLES) IN HORIZONTAL POSITION ONLY AND FOLLOWING SHALL BE CHECKED - OPERATING & CLOSING TIME - OPERATION OF TORQUE &

BHEL		PARTICULARS		BIDDER/VENDOR	
		NAME			
		SIGNATURE			
		DATE			

ANUJ AWASTHI
Engineer, MPL

BIDDER'S/ VENDOR'S COMPANY SEAL



QUALITY PLAN

SHEET 7 OF 8

CUSTOMER: M/S GSECL
VENDOR: LATER

SYSTEM STEAM SERVICE

PROJECT: 1X800 MW WANAKBORI TPS EXT. UNIT-8
Q.P. NO.: PE-QP-408-100-M016
REV.00 dtd. 25-09-2015

ITEM: CAST CARBON STEEL BUTTERFLY VALVE
UPTO SIZE 2000 NB MOTORIZED

SPEC NO.: PE-TS-408-100-M016

SPEC. TITLE STANDARD SPEC. FOR TWO WAY
BF VALVE FOR STEAM SERVICE

SECTION - VOLUME

S.N O.	COMPONENT/ OPERATION	CHARACTERISTICS CHECKED	CAT E- GO RY	TYPE/METH- OD OF CHECK	EXTENT OF CHECK	REFERENCE DOCUMENT	ACCEPTANCE NORMS	FORMAT OF RECORD	AGENCY	REMARKS
									P W V	

		5. GLAND LEAK TEST (TOP GLAND AND BOTTOM FLANGES)	CR	HELIUM LEAK TESTS	100%	APPROVED TEST PROCEDURE	APPROVED TEST PROCEDURE	INSP. REPORT	2 1 -	LIMIT SWITCHES CURRENT DRAWN BY ACTUATORS
		6. VACUUM TEST	CR	VACUUM TEST	100%	APPROVED TEST PROCEDURE	APPROVED TEST PROCEDURE	INSP. REPORT	2 1 --	
		7. PROOF OF DESIGN TEST (LIFE CYCLE TEST)	CR	CYCLE TEST	AS PER AWWA C504 ON ONE SIZE/ TYPE/ SIZE GROUP/ RATING	APPROVED TEST PROCEDURE / AWWA C504/C-516	INSP REPORT	2 1 *		*VERIFICATION OF TEST REPORT OF POD TEST ON SAME. MODEL/TYPE/SIZE/RATING CARRIED OUT EARLIER FOR NTPC PROJECT/ REPUTED CUSTOMER.
4.0	SHIPPING RELEASE									
4.1	FINAL INSPECTION		MA	MEAS.	100%	APPD DRG	INSP REPORT	2 1 -		
		1. OVERALL DIMENSION	MA	REVIEW	100%	APPD DRG/ TECH SPEC	INSP REPORT	2 1 -		
		2. DOCUMENTATION REVIEW	MA	VISUAL	100%	APPD DRG/ TECH SPEC	INSP REPORT	2 1 -		
		3. CLEANLINESS	MA	VIAUAL	100%	APPD DRG/ TECH SPEC	INSP REPORT	2 1 -		
		4. NAMEPLATE	MA	VISUAL & MEASURE- MENT	100%	APPROVED DATA SHEET FROM BHEL/ CUSTOMER	INSPN REPORT	2 2 1		
5.0	PAINTING	1. SURFACE PREPARATION 2. UNIFORMITY & THICKNESS	MA	VISUAL	100%	AS PER TECH SPECIFICATION	(SOFT COPY OF PHOTOGRAPHS)	2 2 1		PHOTOGRAPHS OF VALVES AFTER PACKING TO BE VERIFIED BY BHEL BEFORE ISSUING MDCC
6.0	PACKING	AS PER TECHNICAL SPECIFICATION	MA	VISUAL	100%	AS PER TECH SPECIFICATION		2 2 1		

BHEL		BIDDER/VENDOR	
PARTICULARS		NAME	
SIGNATURE		SIGNATURE	
DATE		DATE	
ANUJ AWASTHI Engineer, MPL			
		BIDDER'S/ VENDOR'S COMPANY SEAL	

		QUALITY PLAN		CUSTOMER: M/S GSECL VENDOR: LATER		PROJECT: 1X800 MW WANAKBORI TPS EXT. UNIT-8 QP NO.: PE-QP-408-100-M016		SPEC NO.: PE-TS-408-100-M016 SPEC. TITLE STANDARD SPEC. FOR TWO WAY BF VALVE FOR STEAM SERVICE		
		SHEET 8 OF 8		SYSTEM STEAM SERVICE		ITEM: CAST CARBON STEEL BUTTERFLY VALVE UPTO SIZE 2000 NB MOTORISED		SECTION - VOLUME		
S.N O.	COMPONENT/ OPERATION	CHARACTERISTICS CHECKED	CAT E- GO RY	TYPE/METH- OD OF CHECK	EXTENT OF CHECK	REFERENCE DOCUMENT	ACCEPTANCE NORMS	FORMAT OF RECORD	AGENCY P W V	REMARKS

NOTES:- CR- MEANS CRITICAL MA- MEANS MAJOR MI- MINOR
 PT-PENETRATION TEST UT- ULTRA SOUND TEST MPI= MAGNETIC PARTICAL EXAMINATION RT= RADIOGRAPHIC TEST
 1- BHEL (PURCHASER) & CUSTOMER 2- VENDOR (MAIN) 3- SUB-VENDOR OF VENDOR

ALL MATERIALS SHALL BE AS PER APPROVED DRGS/ DATA SHEET FOR VALVES. LATEST EDITIONS OF ALL THE ABOVE MENTIONED STANDARDS SHALL BE FOLLOWED.

BHEL		PARTICULARS		BIDDER/VENDOR	
		NAME			
		SIGNATURE			
		DATE			
				BIDDER'S/ VENDOR'S COMPANY SEAL	

Anuj Awasthi
 Engineer, MPL

	TECHNICAL SPECIFICATION BUTTERFLY VALVES (STEAM SERVICE)	SPECIFICATION NO. PE-TS-408-100-M016	
		VOLUME : IIB	
		SECTION: D	
		REV. NO.: 00	DATE: 25.09.2015
		SHEET 1	OF 1

SECTION-D2

ACTUATORS

DATA SHEET – A2 WIRING DIAGRAM

	SPECIFICATION FOR MOTORISED VALVE ACTUATOR	SPECIFICATION NO.: PE-ID-408-145-I902		
		VOLUME	II B	
		SECTION	D	
		REV. NO.	00	DATE: 04.04.15
		SHEET	1	OF 4
Data Sheet A & B				
DATA SHEET-A (TO BE FILLED BY PURCHASER)		DATA SHEET-B (TO BE FILLED-UP BY BIDDER)		

408

GENERAL*	* PROJECT	1X800 MW WANAKBORI TPS Ext. UNIT-8	
	OFFER REFERENCE		
	* TAG NO. SERVICE	EXV-31, EXV-32	TDBFP EXHAUST
	* DUTY	<input checked="" type="checkbox"/> ON / OFF	<input type="checkbox"/> INCHING
	* LINE SIZE (inlet/outlet): MATERIAL		
	* VALVE TYPE	<input type="checkbox"/> GLOBE <input type="checkbox"/> GATE <input type="checkbox"/> REG. GLOBE <input checked="" type="checkbox"/> BUTTERFLY	
	* OPENING / CLOSING TIME		
	* WORKING PRESSURE		
	AMBIENT CONDITION	SHALL BE SUITABLE FOR CONTINUOUS OPERATION UNDER AN AMBIENT TEMP. OF 0-55 DEG C AND RELATIVE HUMIDITY OF 0-95%	
	VALVE SEAT TEST PRESS	BIDDER TO SPECIFY	
	REQUIRED VALVE TORQUE	BIDDER TO SPECIFY	
ACTUATOR RATED TORQUE	BIDDER TO SPECIFY		
CONSTRUCTION AND SIZING	CONSTRUCTION	TOTALLY ENCLOSED, WEATHER PROOF, IPW:55	
	MECHANICAL POSITION INDICATOR	TO BE PROVIDED FOR 0-100% TRAVEL	
	BEARINGS	DOUBLE SHIELDED, GREASE LUBRICATED ANTI-FRICTION.	
	GEAR TRAIN FOR LIMIT SWITCH/TORQUE SWITCH OPERATION	METAL (NOT FIBRE GEARS). SELF-LOCKING TO PREVENT DRIFT UNDER TORQUE SWITCH SPRING PRESSURE WHEN MOTOR IS DE-ENERGIZED.	
	SIZING	OPEN/CLOSE AT RATED SPEED AGAINST DESIGNED DIFFERENTIAL PRESSURE AT 85% OF RATED VOLTAGE. FOR ISOLATING SERVICE THREE SUCCESSIVE OPEN-CLOSE OPERATIONS OR 15 MINS. WHICHEVER IS HIGHER FOR INCHING SERVICE - 150 STARTS/HR MINIMUM & FOR REGULATING SERVICE - 600 STARTS/HR MINIMUM.	
HANDWHEEL	* REQUIRED	<input checked="" type="checkbox"/> YES <input type="checkbox"/> NO	
	* ORIENTATION	<input type="checkbox"/> TOP MOUNTED <input type="checkbox"/> SIDE MOUNTED	
	*TO DISENGAGE AUTOMATICALLY DURING MOTOR OPERATION.		
ELECTRIC ACTUATOR	ACTUATOR MAKE/MODEL	BIDDER TO SPECIFY	
	MOTOR MAKE / MODEL / TYPE / RATING (KW)	BIDDER TO SPECIFY	
	@ MOTOR TYPE	SQUIRREL CAGE INDUCTION MOTOR, STARTING CURRENT LIMITED TO SIX TIMES THE RATED CURRENT- INCLUSIVE OF I.S. TOLERANCE	
	ACTUATOR APPLICABLE WIRING DIAGRAM	<input checked="" type="checkbox"/> ENCLOSED (BIDDER TO CONFIRM) A: <input type="checkbox"/> DRG. NO. 3-V-MISC-24227 R00 B: <input type="checkbox"/> DRG. NO. 3-V-MISC-24550 R00 C: <input type="checkbox"/> DRG. NO. 3-V-MISC-24283 R00 D: <input checked="" type="checkbox"/> DRG. NO. 4-V-MISC-90271 R11 E: <input type="checkbox"/> For Thyristor based Integral starter, Bidder/Vendor to furnish wiring diagram	
	COLOUR SHADE	<input type="checkbox"/> BLUE (RAL 5012) <input type="checkbox"/> (TO BE DECIDED BY BHEL DURING DETAIL ENGG.)	
	PAINT TYPE (## Refer Notes)	<input type="checkbox"/> ENAMEL <input type="checkbox"/> EPOXY <input type="checkbox"/> (TO BE DECIDED BY BHEL DURING DETAIL ENGG.)	
	SHAFT RPM	BIDDER TO SPECIFY	
	OLR SET VALUE	BIDDER TO SPECIFY	
	@ STARTING / FULL LOAD CURRENT	BIDDER TO SPECIFY	
	NO. OF REV FOR FULL TRAVEL	BIDDER TO SPECIFY	

	SPECIFICATION FOR MOTORISED VALVE ACTUATOR	SPECIFICATION NO.: PE-ID-408-145-I902		
		VOLUME	II B	
		SECTION	D	
		REV. NO.	00	DATE: 04.04.15
		SHEET	2	OF 4
Data Sheet A & B				
DATA SHEET-A (TO BE FILLED BY PURCHASER)		DATA SHEET-B (TO BE FILLED-UP BY BIDDER)		

408

	@ PWR SUPP TO MTR / STARTER	415V, 3PH, AC	
	@ CONTROL VOLTAGE REQUIREMENT	TO BE DERIVED FROM THE POWER SUPPLY TO THE STARTER <input type="checkbox"/> 230 V <input checked="" type="checkbox"/> 110 V	
	@ ENCLOSURE CLASS OF MOTOR	<input checked="" type="checkbox"/> IP 65 <input type="checkbox"/> FLAME PROOF	
	@ INSULATION CLASS	CLASS-F TEMP. RISE LIMITED TO CLASS-B	
	@ WINDING TEMP PROTECTION	<input checked="" type="checkbox"/> THERMOSTAT (3 Nos., 1 IN EACH PHASE) <input checked="" type="checkbox"/> ---THERMOSTAT- 1 NO+1 NC CONTACT -----	
	SINGLE PHASE / WRONG PHASE SEQUENCE PROTECTION	REQUIRED	
INTEGRAL STARTER	INTEGRAL STARTER	<input type="checkbox"/> REQUIRED <input checked="" type="checkbox"/> NOT REQUIRED	
	TYPE OF SWITCHING DEVICE	<input type="checkbox"/> CONTACTORS <input type="checkbox"/> THYRISTORS	
	TYPE	<input type="checkbox"/> CONVENTIONAL <input type="checkbox"/> SMART (NON-INTRUSIVE)	
	IF SMART		
	a) SERIAL LINK INTERFACE	<input type="checkbox"/> INTEGRAL <input type="checkbox"/> FIELD MOUNTED	
	b) SERIAL LINK PROTOCOL	<input type="checkbox"/> FOUNDATION FIELD-BUS <input type="checkbox"/> PROFI-BUS <input type="checkbox"/> DEVICE NET <input type="checkbox"/>	
	c) SERIAL LINK MEDIA	<input type="checkbox"/> TWISTED PAIR Cu-CBL <input type="checkbox"/> CO-AXIAL Cu-CBL <input type="checkbox"/> OFC	
	d) HAND HELD PROGRAMMER	<input type="checkbox"/> REQUIRED <input type="checkbox"/> NOT REQUIRED	
	e) TYPE OF HAND HELD PROGRAMMER	<input type="checkbox"/> BLUETOOTH <input type="checkbox"/> INFRARED <input type="checkbox"/>	
	f) MASTER STATION	<input type="checkbox"/> REQUIRED <input type="checkbox"/> NOT REQUIRED	
	g) MASTER STN INTRFACE WITH DCS	<input type="checkbox"/> MODBUS <input type="checkbox"/> TCP/IP	
	h) DETAILS OF SPECIAL CABLE	<input type="checkbox"/> ENCLOSED <input type="checkbox"/> NOT REQUIRED	
	STEP DOWN CONT. TRANSFORMER	<input type="checkbox"/> REQUIRED	
	OPEN / CLOSE PB	<input type="checkbox"/> REQUIRED <input type="checkbox"/> NOT REQUIRED	
	STOP PB	<input type="checkbox"/> REQUIRED <input type="checkbox"/> NOT REQUIRED	
	INDICATING LAMPS	<input type="checkbox"/> REQUIRED <input type="checkbox"/> NOT REQUIRED	
	LOCAL REMOTE S/S	<input type="checkbox"/> REQUIRED <input type="checkbox"/> NOT REQUIRED	
STATUS CONTACTS FOR MONITORING	<input type="checkbox"/> REQUIRED <input type="checkbox"/> NOT REQUIRED		
INTEGRAL STARTER DISTURBED SIGNAL	REQUIRED (O/L RELAY OPERATED, CONT./POWER SUPPLY FAILED, S/S IN LOCAL, TORQUE SWITCH OPTD. MID WAY)		
INTERPOSING RELAY/OPTO COUPLER (Applicable for integral Starter)	TYPE OF ISOLATING DEVICE	<input type="checkbox"/> INTERPOSING RELAY <input type="checkbox"/> OPTO COUPLER <input type="checkbox"/> EITHER	
	QUANTITY	<input type="checkbox"/> 2 NOs. <input type="checkbox"/> 3 NOs.	
	DRIVING VOLTAGE	<input checked="" type="checkbox"/> 20.5 – 24V DC <input type="checkbox"/> _____ V DC	
	DRIVING CURRENT	<input checked="" type="checkbox"/> 125mA MAX <input type="checkbox"/> _____ mA MAX	
	LOAD RESISTANCE	<input checked="" type="checkbox"/> > 192 ohms - <25 k ohms <input type="checkbox"/> > _____ ohms - < _____ ohms	
TORQUE SWITCH (Not Applicable for Smart Actuator) (\$\$ Refer Notes)	MFR & MODEL NO.	BIDDER TO SPECIFY	
	OPEN / CLOSE	<input checked="" type="checkbox"/> 1 No. <input type="checkbox"/> 2Nos. / <input checked="" type="checkbox"/> 1 No. <input type="checkbox"/> 2Nos	
	CONTACT TYPE	2 NO + 2 NC	
	RATING	5A 240V AC AND 0.5A 220V DC	
	CALIBRATED KNOBS(OPEN&CLOSE TS)	REQUIRED FOR SETTING DESIRED TORQUE	
	ACCURACY	+3% OF SET VALUE	

	SPECIFICATION FOR MOTORISED VALVE ACTUATOR	SPECIFICATION NO.: PE-ID-408-145-I902		
		VOLUME	II B	
		SECTION	D	
		REV. NO.	00	DATE: 04.04.15
		SHEET	3	OF 4
Data Sheet A & B				
DATA SHEET-A (TO BE FILLED BY PURCHASER)			DATA SHEET-B (TO BE FILLED-UP BY BIDDER)	

408

LIMIT SWITCH (Not Applicable for Smart Actuator) (\$\$ Refer Notes)	MFR & MODEL NO.	BIDDER TO SPECIFY		
	OPEN : INT : CLOSE	<input type="checkbox"/> 1 No. <input checked="" type="checkbox"/> 2 Nos.	2 Nos. (ADJ.)	<input type="checkbox"/> 1 No. <input checked="" type="checkbox"/> 2Nos.
	CONTACT TYPE	2 NO + 2 NC		
	RATING (AC / DC)	5A 240V AC AND 0.5A 220V DC		

POSITION TRANSMITTER	POSITION TRANSMITTER (For inching duty & other specific applications)	<input checked="" type="checkbox"/> REQUIRED <input type="checkbox"/> NOT REQUIRED
	MFR & MODEL NO.	BIDDER TO SPECIFY
	TYPE	<input checked="" type="checkbox"/> ELECTRONIC (2 WIRE) R/I CONVERTER <input type="checkbox"/> ELECTRONIC (2 WIRE) CONTACTLESS
	SUPPLY	<input checked="" type="checkbox"/> 24V DC <input type="checkbox"/>
	OUTPUT	<input checked="" type="checkbox"/> 4-20mA
	ACCURACY	± 1% FS
SPACE HEATER	@SPACE HEATER	REQUIRED
	@ POWER SUPPLY (NON INTEGRAL)	230V AC, 1 PH., 50 Hz
	@ POWER SUPPLY (INTEGRAL)	BIDDER TO SPECIFY
	@ RATING	decided as per load data received tender stage
TERMINAL BOX	ACTUATOR/MOTOR TERMINAL BOX	REQUIRED
	ENCL CLASS ACTUATOR/MOTOR T.B.	@ <input type="checkbox"/> IP 68 @ <input type="checkbox"/>
	@ EARTHING TERMINAL	REQUIRED
	PLUG & SOCKET (9 PIN) (FOR COMMD, LS/TS FEED BACK, PoT)	<input type="checkbox"/> REQUIRED <input type="checkbox"/> NOT REQUIRED <input type="checkbox"/> 2 NOS. <input type="checkbox"/>
CABLE GLANDS	@ POWER CABLE GLAND	SIZE: decided as per load data received tender stage
	@ SPACE HEATER CABLE GLAND	SIZE: decided as per load data received tender stage
	OTHER CONTROL CABLE GLANDS-1	<input type="checkbox"/> 1No. for BFV of CW PUMP (Cable size 2Px1.5mm ²)
	OTHER CONTROL CABLE GLANDS-2	QUANTITY & SIZE :-

	SPECIFICATION FOR MOTORISED VALVE ACTUATOR	SPECIFICATION NO.: PE-ID-408-145-I902		
		VOLUME	II B	
		SECTION	D	
		REV. NO.	00	DATE: 04.04.15
		SHEET	4	OF 4
Data Sheet A & B				
DATA SHEET-A (TO BE FILLED BY PURCHASER)			DATA SHEET-B (TO BE FILLED-UP BY BIDDER)	

408

WEIGHT	TOTAL WEIGHT (ACTUATOR + ACCESSORIES)	BIDDER TO SPECIFY	_____ Kg.	
<p>NOTES:</p> <ol style="list-style-type: none"> SCOPE: DESIGN, MANUFACTURE, INSPECTION, TESTING AND DELIVERY TO SITE OF ELECTRIC ACTUATOR FOR INCHING OR OPEN / CLOSE DUTY. CODES & STANDARDS: DESIGN AND MATERIALS USED SHALL COMPLY WITH THE RELEVANT LATEST NATIONAL AND INTERNATIONAL STANDARD. AS A MINIMUM, THE FOLLOWING STANDARDS SHALL BE COMPLIED WITH: IS-9334, IS-2147, IS-2148, IS-325, IS-2959, IS-4691 AND IS-4722 TEMPERATURE RISE SHALL BE RESTRICTED TO 70 DEG. C FOR AMBIENT TEMPERATURE OF 50 DEG C. CABLE GLANDS OF DOUBLE COMPRESSION TYPE, BRASS MATERIAL SHALL BE PROVIDED. THE TORQUE SWITCHES SHALL BE PROVIDED WITH MECHANICAL LATCHING DEVICE TO PREVENT OPERATION WHEN UNSEATING FROM THE END POSITIONS. THE LATCHING DEVICE SHALL UNLATCH AS SOON AS THE VALVE LEAVES THE END POSITION. IF SUCH PROVISION IS NOT POSSIBLE, THE TORQUE SWITCHES SHALL BE BYPASSED BY END-POSITION LIMIT SWITCHES WHICH OPENS ON VALVE LEAVING END POSITION. THESE LIMIT SWITCHES ARE ADDITIONAL TO THE NUMBER OF LIMIT SWITCHES SPECIFIED ELSEWHERE. THE MOTOR SHALL OPERATE SATISFACTORILY UNDER THE +/- 10% SUPPLY VOLTAGE VARIATION AT RATED FREQUENCY, -5% TO +3% VARIATION IN FREQUENCY AT RATED SUPPLY VOLTAGE, SIMULTANEOUS VARIATION IN VOLTAGE & FREQUENCY THE SUM OF ABSOLUTE PERCENTAGE NOT EXCEEDING 10%. THE MOTOR SHALL BE SUITABLE FOR DIRECT ON LINE STARTING. CANOPY FOR OUTDOOR SERVICES SHALL BE PROVIDED. <p>\$\$ TORQUE SWITCH & LIMIT SWITCH SHALL ACT INDEPENDENT OF EACH OTHER. TANDEM OPERATION IS NOT ACCEPTABLE.</p> <p>## EPOXY PAINT IS RECOMMENDED FOR COASTAL AREAS.</p>				
NAME SIGNATURE DATE	PREPARED BY	CHECKED BY	APPROVED BY	VENDOR COMPANY SEAL NAME SIGNATURE DATE
<p>NOTES* = TO BE FILLED BY MPL (LEAD AGENCY). @ = TO BE FILLED BY ES</p>				

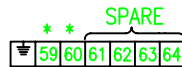
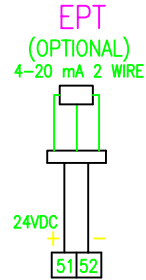
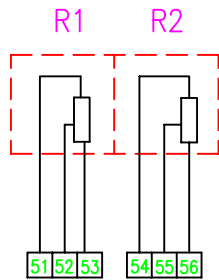
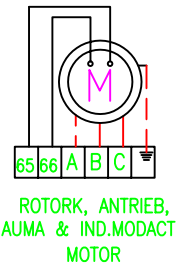
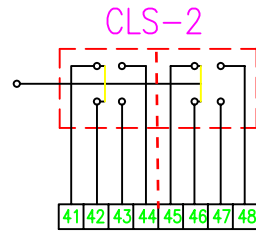
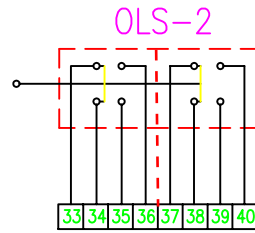
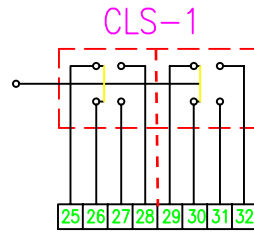
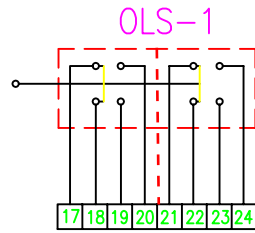
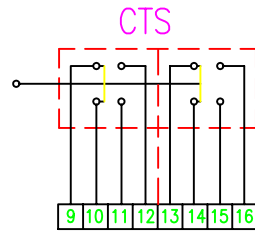
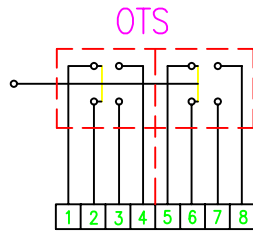
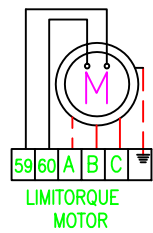

* - SPARE FOR ROTORK, AUMA, ANTRIEB & IND.MODACT

SWITCHES - ALL ARE POTENTIAL FREE AND TWO PAIR OF CONTACTS CAN BE USED FOR DIFFERENT SUPPLY
THERMOSTAT - 65-66 (ROTORK, AUMA, ANTRIEB & IND.MODACT), 59-60 (LIMITORQUE).

EPT - ELECTRONIC POSITION TRANSMITTER (POTENTIOMETRIC TYPE, FOR INCHING DUTY)

THERMOSTAT TERMINALS - TERMINATED IN MOTOR TB IN ANTRIEB & IND.MODACT AND IN MAIN TB IN OTHER MAKES

CTS - TORQUE SWITCHES FOR CW ROTATION (CLOSE) - 2 NO+2 NC

OTS - TORQUE SWITCHES FOR CCW ROTATION (OPEN) - 2 NO+2 NC

OLS-1, OLS-2 - LIMITSWITCHES FOR POSITION OPEN - 2 NO+2 NC

CLS-1, CLS-2 - LIMITSWITCHES FOR POSITION CLOSE - 2 NO+2 NC

OTS, CTS - TWO INDEPENDENT SWITCHES IN ANTRIEB & LIMITORQUE

OLS-2 & CLS-2 - CAM DISC IN ROTORK & ANTRIEB

R1-R2- POTENTIOMETER 2 x 100 OHMS

H - SPACE HEATER 1ϕ 240V AC SUPPLY

M - MOTOR 3ϕ 415V 50 Hz AC SUPPLY

SETTING PROCEDURE OF POSITION LIMIT AND TORQUE SWITCH				
VALVES	OPEN		CLOSE	
	MAIN	BACK UP	MAIN	BACK UP
GATE VALVE OF 100 mm AND ABOVE IN 1500 CL AND ABOVE RATINGS	OLS	OTS	CLS	CTS
ALL OTHER GATE & GLOBE VALVES	OLS	OTS	CTS	⊙

⊙ - CLS NOT TO BE CONNECTED IN TRIP CIRCUIT

NOTE:

1. BYPASS OTS FOR INITIAL 5% OF TRAVEL (FOR GATE VALVES ONLY)
2. CONNECT THERMOSTAT WITHOUT FAIL IN THE STARTER CIRCUIT

CONTACT DEVELOPMENT DIAGRAM				
OTS	1-2	OFF AT OVER TORQUE DURING OPENING TRAVEL		
	3-4	ON AT OVER TORQUE DURING OPENING TRAVEL		
	5-6	OFF AT OVER TORQUE DURING OPENING TRAVEL		
CTS	7-8	ON AT OVER TORQUE DURING OPENING TRAVEL		
	9-10	OFF AT OVER TORQUE DURING CLOSING TRAVEL		
	11-12	ON AT OVER TORQUE DURING CLOSING TRAVEL		
OLS-1	13-14			
	15-16			
	17-18			
CLS-1	19-20			
	21-22			
	23-24			
OLS-2	25-26			
	27-28			
	29-30			
CLS-2	31-32			
	33-34			
	35-36			
SWITCH	37-38			
	39-40			
	41-42			
TERMINAL NO.	43-44			
	45-46			
	47-48			
	FULL OPEN	a	INTERMEDIATE	b
		VALVE POSITION		
		INDICATES CONTACT CLOSED		
		INDICATES CONTACT OPEN		

CONTACT RATING: 5A AT 250V AC & 0.5A AT 220V DC

						BHARAT HEAVY ELECTRICALS LTD. UNIT: HIGH PRESSURE BOILER PLANT. TIRUCHIRAPALLI 620014.	
				365-139			
		DRAWN		N.P.ESWAR		TITLE	
		CHECKED		K.ARUNACHALAM		INTERNAL WIRING DIAGRAM	
		APPROVED		P.LOGANATHAN		FOR	
		DATE		09.09.2000		ELECTRICAL VALVE ACTUATORS (AC)	
		CONTACT DEV. FIG.ADDED.				(DRAWN FOR INTERMEDIATE POSITION OF VALVES)	
11	09.09.2000						
REV	DATE	CHD	APPD	DESCRIPTION	DRAWING No.	4-V-MISC-90271	REV 11

RETRACED WITH REVISION 11

	TECHNICAL SPECIFICATION BUTTERFLY VALVES (STEAM SERVICE) 1X800 MW WANAKBORI TPS EXT. UNIT-8	SPECIFICATION NO. PE-TS-408-100-M016	
		VOLUME : IIB	
		SECTION: D	
		REV. NO.: 00	DATE: 25.09.2015
		SHEET 1 OF 1	

DATA SHEET - C

Drawings/documents distribution schedule to be followed by the successful bidder:

1.0 The successful bidder shall submit the following drawings/documents within two weeks after award of contact.

1.1 Relevant drawings/leaflets for the valves showing following information.

- i) Complete cross sectional arrangement of the valve.
- ii) Binding dimensions, dismantling clearances & weights.
- iii) Bill of material incorporating all the materials of construction of various parts along with BS/ASTM/IS standards to which the materials conform to.
- iv) Special features, if any, as called for in the specific requirement
- v) Type of oil/Grease wherever required and its annual consumption.

1.2 Relevant catalogue/leaflet of the actuators

1.3 Torque calculations of actuator selected.

1.4 Actuator data sheet with Wiring Diagram.

1.5 Quality Plan duly signed & stamped with bidder's seal.

2.0 The following shall be submitted within the stipulated time period as per vendor's drawings/ documents schedule, but not later than one month before first dispatch.

- a) Drawings of components & details as deemed necessary.
- b) Instruction manual for erection, operation and maintenance.
- c) Storage instructions.

3.0 Before dispatch of the equipment the vendor shall furnish the following.

- a) Material Test certificates.
- b) Shop test reports and certificates.

4.0 Distribution of drawings / documents for all projects:

After award of the contract the successful bidder shall furnish drawings/ documents as per following distribution schedule.

Sl. No.	Type of Document	No of Hard copies	No. of Soft copies
1	Documents submitted for Approval	2 Nos.	1 Nos.
2	Final Distribution(Approved Documents)	10 Nos.	4 Nos.
3	O&M Manuals	11 Nos.	4 Nos.

1X800 MW WANAKBORI TPS EXT. UNIT-8

VOLUME – III

TECHNICAL SCHEDULES

FOR

BUTTERFLY VALVES (STEAM SERVICE)

SPECIFICATION NO. PE-TS-408-100-M016



**BHARAT HEAVY ELECTRICALS LIMITED, POWER SECTOR
PROJECT ENGINEERING MANAGEMENT
NOIDA, INDIA**

	BUTTERFLY VALVES (STEAM SERVICE) 1X800 MW WANAKBORI TPS EXT. UNIT-8	SPECIFICATION NO. PE-TS-408-100-M016	
		VOLUME : III	
		SECTION:	
		REV. NO.: 00	DATE: 25.09.2015
		SHEET 1 OF 1	

CONTENTS

SL.NO	TITLE
1	COMPLIANCE SHEET
2	SCHEDULE OF DEVIATIONS
3	SCHEDULE OF DECLARATIONS
4	SCHEDULE OF PRICES

	COMPLIANCE SHEET BUTTERFLY VALVES (STEAM SERVICE) 1X800 MW WANAKBORI TPS EXT. UNIT-8	SPECIFICATION NO.:PE-TS-408-100-M016	
		VOLUME : III	
		SECTION:	
		REV. NO. 00	DATE : 25.09.2015
		SHEET 1 OF 2	

The bidder shall sign and return a copy of this compliance sheet along with his offer, indicating his compliance to the points specified herein:

A) Technical Details: Bidder to tick whichever is applicable.

1.	Technical requirements as per Data sheet-A1 & Standard Technical Specification of Vol IIB Section-D	Accepted	Not Accepted
2.	Technical requirements as per Data sheet-A2 (Actuator data sheet with wiring diagram) of Vol IIB Section-D	Accepted	Not Accepted
3.	Quality Plan	Accepted	Not Accepted
4.	Specific Technical requirements of Vol IIB Section-C	Accepted	Not Accepted
5.	Documentation requirement as per Data sheet-C of Vol IIB Section-D	Accepted	Not Accepted

B) Deviations to the technical specification are not acceptable. However, if there are any deviations due to unavoidable reasons then the same to be clearly specified in the schedule of deviation. In case of no deviations, schedule of deviations to be filled as NIL by bidder.

C) The offered materials should be either equivalent or superior to those specified. Also for components where material is not specified, the material used shall be suitable for intended duty.

D) QP/ test procedures shall be submitted in the event of order based on the guidelines given in the specification & QP enclosed therein. QP will be subject to BHEL/Customer approval in the event of order & customer hold points for inspection/ testing shall be marked in the QP at the contract stage. All Inspection/ testing shall be as per approved QP. The charges for 3rd party inspection (Lloyds, TUV or equivalent) for foreign bidders shall be included in the base price of the equipment by the bidder. This 3rd party inspection agency shall be approved by BHEL and will be decided in contract stage.

E) Valve POD test, Gear box POD test and Actuator POD test or any other test required as per this technical specification & AWWA-C516-10, vendor shall submit the reports of the type tests carried out within last 5 years from the date of bid opening i.e. (21-Oct-2014) of project and shall be considered applicable for this project only, if found satisfactorily by BHEL. These reports should be for the tests conducted on the equipment/items same (model / type/ size / rating) to those proposed to be supplied. Tests should have been conducted at an independent laboratory or should have been witnessed by a client.

PARTICULARS OF BIDDER / AUTHORISED REPRESENTATIVE				
NAME	DESIGNATION	SIGNATURE	DATE	COMPANY SEAL

	COMPLIANCE SHEET BUTTERFLY VALVES (STEAM SERVICE) 1X800 MW WANAKBORI TPS EXT. UNIT-8	SPECIFICATION NO.:PE-TS-408-100-M016	
		VOLUME : III	
		SECTION:	
		REV. NO. 00	DATE : 25.09.2015
		SHEET 2 OF 2	

- F) In case the bidder has not carried Valve POD test, Gear box POD test and Actuator POD test or any other test required as per this technical specification & AWWA-C516-10 then the charges for the same shall deemed to be included in the unit Quoted prices of main valves as these tests are mandatory requirements of valve governing Standard AWWA-C516-10 and this enquiry specification. No extra charge on this account is admissible to bidders.
- G) All drawings/data – sheets etc. to be submitted during contract shall be subject to BHEL/Customer review/ approval.
- H) GA drawings, as submitted with offer at tender stage are for reference purpose only and shall be subject to approval during contract stage.
- I) The commissioning spares (if any) are supplied on ‘As Required Basis’ & prices for same shall be quoted in the price bid format. If the bidder has not quoted for commissioning spares at tender stage and if the same are actually required during commissioning, then the same shall be supplied by bidder without any cost to BHEL.
- J) All drawings/documents in soft as well as hard copy shall be submitted within 2 weeks from placement of Purchase orders in the event of order. A technical representative of bidder shall come for meeting with BHEL along with revised documents within one week of receipt of BHEL comments to resolve all issues and incorporate all comments in the soft copy for further submission to customer if required. Further, on receipt of customer comments on the documents a technical representative from bidder shall come for meeting to resolve all issues and incorporate all comments in the soft copy at BHEL and resubmit the drawings /documents for CAT I approval and shall visit customer/customer’s consultant if required for across the table approval of documents.
- K) Any special tools & tackles, if required, shall be in bidder’s scope.
- L) The offered model design should be of bidder’s proven model and they should have designed, manufactured, supplied and tested the equipment of similar type and rating in at least Two (2) projects and be in satisfactory operation for last two (2) years.

PARTICULARS OF BIDDER / AUTHORISED REPRESENTATIVE				
NAME	DESIGNATION	SIGNATURE	DATE	COMPANY SEAL



TITLE
*** SCHEDULE OF DEVIATIONS**
() From Technical Specifications (Volume –II B)

SPECIFICATION NO
PE-TS-408-100-M16

VOL III

SHEET..... OF.....

We the undersigned hereby certify that the above mentioned are the only deviations.

PARTICULARS OF BIDDER / AUTHORISED REPRESENTATIVE				COMPANY SEAL
NAME	DESIGNATION	SIGNATURE	DATE	

	TITLE *SCHEDULE OF DECLARATIONS	SPECIFICATION NO PE-TS-408-100-M016
		VOL III
		SHEET..... OF.....

* Bidder shall include this schedule both in technical and Price offers

DECLARATION

Icertify that all the technical data and information pertaining to this specification are correct and are true representation of the equipment/system covered by our format proposal number Dated and there is no deviation to the specification other than those listed in “Schedule of deviations” of this Vol III.

I hereby certify that I am duly authorized representative of the Bidder’s company whose name appears above my signature.

Bidder’s Company Name

Authorized representatives
Signature

Name

Bidder’s Name

The bidder hereby agrees to fully comply with the requirements and intent of this specification for the price indicated

PARTICULARS OF BIDDER / AUTHORISED REPRESENTATIVE				
NAME	DESIGNATION	SIGNATURE	DATE	
				COMPANY SEAL