



**Bharat Heavy Electrical Ltd
Electronics Division
Mysore Road, Bangalore-560026**

**Tender Document (Techno-commercial)
for the work of:**

**“AIR CONDITIONING SYSTEM FOR BUILDING
NO.18.”**

Opening Date: 22.03.2013

This Tender document contains 93+05 pages

- I. Technical Bid: Pages from 1-93(Part-I)
- II. Price Bid : Pages from 1-5(Part-II)

Issued to:



Phone: 26998424 / 26989192

NOTICE INVITING TENDERS

01. Tender Number : BHEL/EDN/FS/PK/B18/AC/12-13
02. Name of work : “ **Air Conditioning System for building no.18.**”
03. Completion Time : 10 Months
04. Estimated Cost : Rs.45.50 Lakh (Rupees Forty Five lakh Fifty Thousand only)
05. Earnest Money Deposit : Rs. 1,00,000/- (Rupees one Lakh only)
06. Last Date & Time for the Receipt of Completed Tender. : Before 2.30 PM on 22.03.2013
07. Date & Time for Tender Opening : At 2.45 PM on 22.03.2013
08. Place of submission of Tender : Tender Box marked as “Factory Services” and located at Reception Area of Electronics Division, BHEL Mysore Road, Bangalore-26.
09. Tender Contents: This tender document contains 93 Pages (Part-I) and 05 pages (Part-II) consisting of the following:
 - i. Technical-cum-Commercial Bid (Part-I): Comprising the following:-
 - a) NIT, Instructions to Tenderers.
 - b) Scope of work (Technical Specifications / Standards / Norms including makes of equipments / material).
 - c) Details of technical parameters to be furnished by tenderers.
 - d) Block diagram showing arrangement of equipment at Building 18 & Tentative layout of ducting in the Catering area.
 - e) Questionnaire
 - f) General Conditions of Contract
 - ii. Schedule of Work / Price Bid (Part-II): Comprising Bill of Quantities where in the tenderers will submit their Price Bid furnishing the rates and amounts.
10. **Note:**
 1. The tenderer shall read the tender documents carefully and fill all the columns neatly. Incomplete tenders may be rejected.
 2. The tenderer shall return the duly filled in tender document after affixing signature on all pages.
 3. The Tenderers shall ensure and put “Technical-cum-Commercial bid (Part - I)” & “Instructions to Tenderers” together in one cover and “Schedule of Work / Price bid (Part-II)” in a separate cover. Both these covers shall be separately sealed and then put together in a single cover and sealed. Name of work and due date for opening shall be super scribed on the envelopes and all the sealed covers shall be properly identified with necessary information such as Tender reference, type of document put inside, date of tender opening to enable to open the correct document cover only.
 4. The tenderer shall submit EMD of Rs.1,00,000/-(Rupees One Lakh) in favour of BHEL/EDN. Pay order/cash(As permissible under Income Tax Act)



PART-1

TECHNICAL-CUM-COMMERCIAL BIDS

Name of Work: “ Air Conditioning System for building no.18.”

Tender Ref : BHEL/EDN/FS/PK/B18/AC/12-13

Completion Period :10 Months

A. Information Part:

S.N.	Particulars	To be Filled by Bidder
1.0	Name of the Contractor	
2.0	Address (Office)	
3.0	Telephone Number	
	Office	
	Fax No.	
	Mobile No.	
4.0	E-mail ID	
5.0	Technical Staff Details (Use separate sheet if reqd.)	Furnished / Not Furnished
6.0	Working Staff Details (Use separate sheet if reqd.)	Furnished / Not Furnished
7.0	Plant & Equipment details (Use separate sheet if reqd.)	Furnished / Not Furnished



B. Essential Criteria for Techno-Commercial Acceptance of Bid:

S.N.	Particulars	To be Filled by Bidder
1.0	Experience Certificate for having successfully completed centralised Air-conditioning works during immediate last 7 years as mentioned below : One work not less than 80% of the estimated cost of this NIT or Two works of not less than 50% of the estimated cost of this NIT or Three works of not less than 40% of the estimated cost of this NIT copy of completion certificates from the organization where the work is executed is to be enclosed mentioning the completed value of each single work executed and performance certificate issued by the client. (submission of work order copy is not adequate)	
2.0	Average Turn Over of the last three years (not less than 30% of the estimated cost of the NIT)	
2.1	Turn over – Previous financial year	Rs.
2.2	Turn over – 1 Year before previous financial year	Rs.
2.3	Turn over – 2 Years before previous financial year	Rs.
3.0	Solvency : Not less than 30% of the estimated cost of the NIT, Certificate from the Bank (not older than one year to be furnished)	Furnished / Not Furnished.
4.0	Whether Registered with ESI / PF Authority	Yes / No
4.1	If Yes, indicate PF Registration No. (Copy of last month contribution paid receipt to be enclosed)	Enclosed / Not Enclosed.
4.2	If Yes, indicate ESI Registration No. (Copy of last month contribution paid receipt to be enclosed)	Enclosed / Not Enclosed.
4.3	If No, whether the tenderer is willing to obtain ESI and PF registration before commencement of work .	Yes / No. (If No Tender shall be rejected)
5.0	PAN No. of the tenderer(Copy of the same is to be enclosed)	Enclosed / Not Enclosed

Note: If any of the above-mentioned criteria is not met the bid will be rejected.



C. Other Conditions:

S.N.	Particulars	To be Filled by Bidder
1.0	Form of EMD furnished (Cheque is not acceptable)	DD / Pay Order / Cash(as permissible under the Income Tax Act) Document No. to be mentioned.
2.0	Electronic Funds Transfer(EFT) form (Ref Annexure A in the Tender Document) Duly Filled and certified through bank may be enclosed	Enclosed/Not Enclosed
3.0	Has the Tenderer read General Conditions of Contract & NIT	Tender Conditions Acceptable / Not Acceptable
4.0	Completion period mentioned in NIT	Acceptable / Not Acceptable
5.0	Payment Terms defined in NIT	Acceptable / Not Acceptable
6.0	Security Deposit	Acceptable / Not Acceptable



INSTRUCTIONS TO TENDERERS

1. Sealed Tenders for the above noted work are hereby invited from Contractors experienced in works of similar kind and magnitude.
2. Tenders should be addressed to Dy. General Manager (FS), Electronics Division, Bharat Heavy Electricals Limited, Mysore Road, Bangalore – 560 026. The full name and address of the tenderer, name of the work and the date of opening should be indicated on the cover.
- 2.1 The local address of the Contractor, the name of the person to whom all the correspondence are to be addressed should be indicated with office telephone number , FAX /e-mail address, Mobile phone No. etc.
3. All entries in the tender documents should be in the same ink. Erasures and over writing are not permitted. The tenderer concerned with proper indication of the name, designation and address of the person signing should duly sign all cancellations and insertions.
4. Tenderers shall fill in all the required particulars in the blank spaces provided for this purpose in the tender documents and also sign each and every page of the tender document including the drawings (wherever applicable) attached there to before submitting tender.
5. Unit rates should be quoted in figures as well as in words in Indian Currency only i.e. Rupees and Paise with reference to each item and for all the items shown in the attached schedule. The rates shall include all taxes and duties payable on account of Service Tax, Sales Tax etc., and also expenses towards PF and ESI contributions (see clauses 8, 39 and Annexure ‘C’). Amount of each item and the total on each sheet as also the grand total amount of the whole contract shall be filled by the tenderers.
6. In case the rate quoted in figures differ from those quoted in words, the lower of the rates will be taken as the tendered rate and shall be binding on the tenderers.
7. In quoting their rates, the tenderers are advised to take into account all factors including any fluctuations in market rates. No claim for enhanced rates will be entertained on this account after acceptance of the tender or during the currency of the contract.
8. The rates to be quoted by the tenderer shall be firm and shall cover and include all statutory levies arising from Acts, passed by Parliament or by State legislature and rules framed there under. The rates shall further be deemed to include statutory levies arising from such Acts, Central or State, which may come into force, subsequent to submission of tenders. The tenderer shall note that no claim for enhancement of rates, on the ground that existing statutory levies have been increased or that new statutory levies have come into effect after tender, or on any other ground, will be entertained on any account.
9. (a) The rates quoted in the tender shall remain valid for a period of ‘THREE MONTHS’ from the date of opening of tender.

(b) Tenderer shall not increase their quoted rates, once the tenderer has submitted his quotation and during execution of the contract in case his tender is accepted.



10. Quantities shown in the attached schedule are only approximate and are liable to variation without entitling the Contractor to any compensation, provided the total value of the contract does not vary by more than 20 % (twenty percent).
11. Before tendering, the tenderers are advised to inspect the site of work and its environments and be well acquainted with the actual working and other prevailing conditions, position of materials and labour. They should be well versed with BHEL General Conditions of Contract, Instructions to tenderers, drawing wherever applicable and specifications and all other documents which form part of the agreement to be entered into subsequent to award of work. The tenderers shall specially note that it is the tenderer's responsibility to provide any item which is not specially mentioned in the specification or drawing, but which is necessary to complete the work.
12. Details and quantities of each item of work shown in the "Bill of Quantities" attached here to be only approximate. They are given as a guide for the purpose of tendering only and are liable to variation and alteration at the discretion of the competent authority. The work under each item as executed shall be measured and priced at the corresponding rates to be quoted by the contractor in the Bill of Quantities attached here to.
13. Should a tenderer find discrepancies or omissions in the drawings wherever applicable / Specifications / Scope of work / Terms & Conditions attached to the tender documents or should be in doubt as to their meaning, he should at once address to the authority inviting the tender for clarifications.
Every endeavour is made to avoid any error which can materially affect the basis of the tender but the successful tenderer shall take upon himself to provide for the risk of any error which may be subsequently discovered and shall make no subsequent claim on account thereof.
14. In the event of tender being submitted by a firm, the tender must be signed separately and legibly by each partner or member of the firm or in their absence, by the person holding the power of Attorney on behalf of the firm concerned. In the latter case, a copy of the power of attorney duly attested by a Gazetted officer must accompany the tender.
15. In case, the date of tender opening falls on Holiday, the tender will be opened on the next working day.
16. Every tender must be accompanied by deposit receipt for the amount mentioned as Earnest Money Deposit. This earnest money will be refunded to the unsuccessful tenderers after finalisation of the award of work. In the case of successful tenderer, the earnest money will be retained as part of the Security Deposit for satisfactory completion of the work. Tenders without Earnest Money Deposit receipts are liable to be rejected. No interest will be paid on the earnest money deposits.
17. The Earnest Money Deposit shall be submitted along with Technical bid and may be furnished in any of the following forms :
 - (a) Cash(As permissible under income Tax Act)
 - (b) Pay Order / Demand Draft in favour of BHEL EDN
18. Unless the Contractor whose tender is accepted signs the contract agreement within fifteen days (15 days) of the date of the order directing him to do so, the amount of Earnest Money already deposited by him may be forfeited and acceptance of his tender withdrawn.



19. If, after opening of tenders, a tenderer revokes his tender or increases his earlier quoted rates or after acceptance of his tender does not commence the work in accordance with the instructions of Engineer-in-charge, the Earnest Money Deposited by him will be forfeited and acceptance of his tender withdrawn. If only a part of the work included in the tender had been awarded to the tenderer, the amount of Earnest Money to be forfeited will be based on the value of the contract so awarded.
20. BHARAT HEAVY ELECTRICALS LIMITED reserves the right to reject any or all the tenders received or accept any tender or part thereof without assigning any reason thereof. In the case of acceptance of a part of tender, the time for completion may also be reduced to the extent considered appropriate by the accepting authority.
21. Conditional and unsigned tenders, tenders containing absurd rates and amounts, tenders which are incomplete or otherwise considered defective, tenders which are not in accordance with the tender conditions laid down by the Accepting Officer and tenders not submitted in the prescribed forms are liable to be rejected.
22. The contractors who are not on the approved list of contractors of this organisation must submit the following testimonials simultaneously with their tenders. These testimonials shall be signed by the person (s) issuing the same indicating their name, designation and full address.
 - i) A certificate to establish that the tenderer is an independent contractor working on his own.
 - ii) At least 2 certificates from responsible officers of Government or firms of repute, regarding the tenderer's capacity to undertake and carryout the work tendered for / similar work satisfactorily.
 - iii) A certificate from a Bank of standing or magistrate regarding the tenderer's financial position.

Note: (a) Copies of testimonials unless attested by a Gazetted Officer will not be accepted.
(b) Non – submission of the above testimonials simultaneously with the tenders may result in the tenders being rejected.
23. The tenders should be accompanied by a list of contracts already held by the Contractor at the time of submitting the tender and giving the following particulars:
 - (a) Name of work, value and address.
 - (b) The balance work remaining to be done on the same.
24. Tenders submitted by post should be sent by "Registered Post with Acknowledgement due". These should be posted with due consideration for any delay in postal delivery. Tenders received after the due date of opening of tenders are liable to be rejected.
25. The Contractor's responsibility under this contract shall commence from the date of receipt of the order or acceptance of his tender.



26. If a tenderer expires after the submission of his tender or after the acceptance of his tender, BHEL may, at their discretion, cancel such tender.
- If a partner of the firm expires after the submission of the Tender, after the acceptance of the Tender, BHEL may cancel such Tender at the discretion unless the firm retains its character(s).
27. BHARAT HEAVY ELECTRICALS LIMITED will not be bound by any power of Attorney granted by the tenderer or by changes in the composition of the firm made subsequent to the execution of the contract. They may however, recognise such power of Attorney and changes after obtaining proper legal advice, the cost of which will be chargeable to the contractor concerned.
28. If the tenderer deliberately gives wrong information in his tender, BHEL reserves the right to reject such tender at any stage. Further the tenderer will be liable for any damage caused.
29. Words imparting the singular number shall be deemed to include the plural number and vice-versa where the context so requires.
30. The General and Special Conditions of Contract are complementary to each other and where they are in conflict, the special condition shall prevail.
31. The expenses for completing the stamping the agreement shall be paid by the contractor.
32. Unless and otherwise stated all tendered work includes supply, erection, testing and commissioning of equipment as agreed to in the contract.
33. After completion of the job, the contractor has to furnish actual drawings of work done in consultation with Engineer-in-charge.
34. Any covering letter and comments of the Contractor should be submitted in duplicate along with the offer.
35. The Contractor shall provide all the materials needed for trial run, testing including chemicals, consumables etc. In quoting their rates, the Contractors are advised to take into account the cost of the above materials.
36. Should a tenderer or a contractor on the list of approved contractors have a relative or in the case of firm or Company of Contractors any of its share holder's relative is employed in a Gazetted Capacity in the Electronics Division of Bharat Heavy Electricals Limited, Bangalore-26, the authority inviting tenders shall be informed of this fact at the time of submission of the tender, failing which tender may be disqualified or if such a fact subsequently come to light, the relevant provisions of the General Conditions of Contract will apply.
37. These 'INSTRUCTIONS TO TENDERERS' & 'GENERAL CONDITIONS OF CONTRACT OF BHEL shall be deemed to form an integral part of the contract agreement for the work to be entered into. In cases of variation between the two in any matter, the conditions in the 'THE INSTRUCTIONS TO TENDERERS' shall prevail. Extracts of some of the important clauses of BHEL GCC are enclosed (Annexure



- containing extracts of clauses 20, 38 and 58 of BHEL GCC). The contractor has to obtain, at his cost, a copy of the BHEL GCC, scrutinize the same, and when submitting his tender, indicate his acceptance of BHEL GCC in the proforma enclosed at Annexure B.
- 38 All operations to be carried out by the Contractor during the execution of the contract such as drilling, welding etc., shall be done with proper equipment brought by the tenderer. Suitable power point will be provided and tapping from the power point to equipment shall be done using proper size of cable, equipment and after getting approval of connections from our Engineer-in-charge.
- 39 The Contractor shall comply with the provision of Employees Provident Fund and Miscellaneous Provisions Act 1952 and rules, regulations and other orders issued there under. He, as an employer, shall be liable to pay employer's contribution/deductions towards PF under the PF Act in respect of all labour employed by him, for the execution of the contract in accordance with the provisions of the Employees Provident Funds and Miscellaneous Provisions Act, 1952 as amended from time to time. For this purpose he shall indicate the code number obtained from the Regional Provident Fund Commissioner or he should obtain a code number if he has not and produce the Photostat copy of the challan / receipt of monthly remittance of the contribution made by him to the PF Commissioner. Final payments due to him will be released only on production of a "No due certificate" from the Regional Provident Fund Commissioner wherever applicable. He shall also furnish such returns as are due, under the Act, to be sent to the appropriate authorities through the Principal Employer".
- 40 The Contractor should get himself registered with the E.S.I. Authorities as an independent Employer, obtain a separate code number and remit the dues in respect of the labour employed by him for the work and produce the Challans / Receipts of remittance of the ESI contributions due under the E.S.I. Act to the Company authorities. He shall also furnish such returns, as are due, under the Act, to be sent to the appropriate authorities through the Principal Employer.
- 40.1 If any action is brought in by P.F. Commissioner/ESI authorities on BHEL for the work done by the Contractor for his labourers regarding PF/ESI amount due, short remittances, non remittances etc., the Contractor shall defend the case on behalf of BHEL and/or reimburse BHEL the expenses so incurred.
- 40.2 If applicable, the Contractor shall apply and obtain license under Contract labour (R&A) Act 1970 and comply with the relevant provisions of this Act in respect of the labour employed by him for executing this contract. The Contractor shall furnish necessary returns to the authority through the Principal Employer.
- 41 If applicable, the Contractor shall insure all his labourers and materials. Any claim by his employees for the damages shall be settled by the contractor even action is against BHEL or to reimburse the legal expenses incurred by BHEL
- 42 Any action brought in by anybody on BHEL regarding patent, right etc., used by contractor in execution of work shall be defended by the contractor and / or reimburse to BHEL the cost of the same.
- 43 Contractor shall produce necessary records, documents, explanation whenever he is called upon to do, by any Government. Agencies like ESI, PF, VIGILANCE etc.



44 TERMS OF PAYMENT :

- a) 56.25% of total contract value will be paid against the supply of materials at site and acceptance on prorata basis.
- b) 33.75 % of the contract value will be paid on completion of erection on prorata basis.
- c) Balance 10 % of the contract value will be paid after;
 - i) Satisfactory commissioning and handing over the entire system and
 - ii) On your submitting a Bank Guarantee for a value of 50 % of the Security Deposit towards performance guarantee to the extent required to cover the warrantee period.
 - iii) For the works which do not involve supply of materials, erection and commissioning, the terms of payment will be as per discretion of Executive in charge of BHEL.

45 SECURITY DEPOSIT

45.1 The successful tenderer shall deposit the Security deposit before start of the work. The rate of Security deposit will be as below.

Upto Rs. 10 Lakhs	10 %
Above Rs. 10 Lakhs upto Rs. 50 Lakhs	Rs. 1 Lakh + 7.5% of the amount exceeding Rs. 10 Lakhs
Above Rs. 50 Lakhs	Rs. 4 Lakhs + 5 % of the amount exceeding Rs. 50 Lakhs

45.2 Security deposit may be furnished in any one of the following forms

- i) Cash (as permissible under the Income Tax Act)
- ii) Pay Order, Demand Draft in favour of BHEL
- iii) Local Cheques of scheduled banks, subject to realization.
- iv) Securities available from Post Offices such as National Savings Certificates, Kisan Vikas Patras etc. (Certificates should be held in the name of Contractor furnishing the security and duly pledged in favour of BHEL and discharged on the back)
- v) Bank Guarantee from scheduled Banks / Public Financial Institutions as defined in the Companies Act. The Bank Guarantee format should have the approval of BHEL.
- vi) Fixed Deposit Receipt issued by Scheduled Banks / Public Financial Institutions as defined in the Companies Act. The FDR should be in the name of the contractor, A/C. BHEL, duly discharged on the back.



- vii) Security Deposit can also be recovered at the rate of 10% from the running bills. However in such cases at least 50% of Security Deposit shall be deposited before start of the work and the balance 50% may be recovered from the running bills.
- viii) EMD of the successful tenderer shall be converted and adjusted against the security deposit.
- ix) The Security deposit shall not carry any interest.

(NOTE: Acceptance of Security Deposit against Sl. No. (iv) and (vi) above will subject to hypothecation or endorsement on the document in favour of BHEL. However, BHEL will not be liable or responsible in any matter for the collection of interest or renewal of the documents or in any other matter connected therewith.)

46 RUNNING ACCOUNT PAYMENTS

During execution of work, payments of all works in place will be made on the basis of measurements recorded in measurement sheet / book in respect of items executed but no claim on the account will be entertained, if for any reason payments are not so made.

- 47 The work shall be carried out as per detailed specifications enclosed with the tender. The items for which there is no mention in the drawings, detailed specifications to relevant IS Specifications (latest edition) shall be followed.

48 CLEANING OF SITE:

After completion of the work, the contractor shall remove all debris, take away left over construction materials, machine, equipment, temporary offices, stores, work shop etc. and make the area neat and clean. The cost of this work shall be included in the quoted rate.

49 COMPLETION OF WORK AND MEASUREMENT

- a) On completion of the work, the contractor must submit to the Engineer-in-charge the following documents for passing of works.
- b) A copy of the working drawing showing thereon all addition and alterations in the process of execution and.
- c) The authorised Contractor's representative and a representative of the Employer shall jointly sign a certificate of handing over of any completed work and the date of signature of that certificate will be that the date from which the maintenance period of that unit will be reckoned.

50 MAINTENANCE OF WORKS

The contractor will be responsible for the maintenance of works during the period of execution until the various items are taken over, and for a further period of Six months, from the date of taking over.

51 EXTRA ITEMS :

No extra items of work shall be carried out by the contractor other than those authorised to do so in writing by the Engineer. For any such items of work executed as per instructions of Engineer. The rates will be fixed on the basis indicated under clause 50 of BHEL GCC.



52 SUPPLY OF MATERIALS BY CONTRACTOR :

- i) The work is for a completed job including labour and supply of all except those otherwise specified in the bid document.
- ii) All materials supplied by the contractor according to the contract conditions shall be subject to inspection and passing by the Engineer-in-charge or his representatives from time to time, the contractor shall provide all facilities for such inspection free cost. BHEL officers connected with the contract shall have the power at any time to inspect and examine any stores or materials intended to be used in or on the work, whether on the site or at any factory or workshop or other place the same are laying and the contractor shall give necessary facilities for such inspection and examination.
- iii) The contractor shall submit necessary Test Certificate / Calibration certificate for the critical items wherever necessary.

53 INTERRUPTION TO WORKS :

- i) In quoting the rates / prices the contractor should take in to account the fact that due to the design or other stipulations at site, or the necessity to follow a particular sequence of overall construction operation, or non – supply of particular drawings, or the connected work or other reasons, interruptions are likely to be encountered in a work of this nature and magnitude. No claims for such interruption will be entertained on any account.
- ii) Extension of time or penalty / liquidated damages as the case may be will be determined as stipulated in clause 7, 9 and 41 of BHEL General Conditions of Contract.



SCOPE OF WORK

INTRODUCTION

The Building no.18 is located in Bharat Heavy Electricals Ltd Electronics Division premises at Mysore Road ,Bangalore-26. Presently the building is under construction and is coming fast. The building will have three floors where in one floor has been earmarked for production area. The proposed Air conditioned system will be catering to the production area .The specifications cover supply, installation, testing, commissioning and handing over of Air-conditioning systems for proposed PV Module Area at Building no.18. The scheme and type of equipments which will be used for providing air conditioning system shall comprise of following :-

1. Supply, installation ,testing and commissioning of Air conditioning system with Horizontal Type double skinned ,floor mounted DX type Air Handling Units of Capacity 12500 cfm ,33TR with housing, fan, motor, filters, Thermostatic expansion valve and cooling coil.
2. Supply installation, testing and commissioning of air cooled condensing units(Outdoor Units) of capacity 11 TR with scroll compressor(S), condenser coils and fans.
3. The scheme of air conditioning system has been briefly explained with block diagram attached at page no.29. It is proposed to install three sets of 33 TR System wherein each set will comprise of one DX-AHU(12500 cfm,33TR) connected to three condensing units of 11 TR with copper pipes ,valves and other accessories. For catering the air-conditioned area two such system will remain as working and one set will remain as stand-by.
4. Supply, installation, testing and commissioning of suitable copper pipes with nitrile rubber insulation.
5. Supply, installation, testing commissioning of microprocessor based control panel with suitable starters and interlocks for each set of 33TR System. The control Panel shall have feature to re-start automatically on resumption of power supply after power failure.
6. Supply ,installation, testing and commissioning of main power panel along with laying of associated power cable/control cable/earthing/grounding between panel and various components of Air conditioning system.
7. The distribution of air inside the catering area will be done uniformly through grille with dampers on Spiral/Elliptical ducting. The supply air Spiral/Elliptical ducting will be connected to plenum through rectangular duct /transition piece. The return air will be drawn to AHU room through opening in catering area and rectangular duct. All ducts which will be exposed to atmosphere will be insulated. A drawing showing tentative layout of ducting inside has been enclosed at page no 30.
8. Supply ,Installation and Testing & Commissioning of Volume control Dampers of required size with flexible canvas from Outlet of AHUs to the plenum.
9. Supply ,Installation and Testing & Commissioning of G.I Fire dampers with fusible plug in



supply air duct. All branches of the main duct in the catering area shall be provided with Volume Control Dampers.

10. Supply ,Installation and Testing & Commissioning of G.I back draft dampers in return air opening .
11. The contractor shall include all minor civil works such as breaking and making good of openings in wall / ceiling / floor for the passage of refrigerant pipes, drain pipes, cables, supply & return ducts and earth wires.
12. The successful contractor has to co-ordinate with other agencies such as electrical, civil, fire fighting, etc. as required.
13. Tail end thermal insulation of ducting shall be provided as required.
14. Necessary mounting frames / supporting arrangements for the AHUs, condensing units panel etc. shall be provided by the air conditioning contractor.
15. The air conditioning system should have provision for interlocking with the fire alarm system. Suitable potential free contact points shall be included for the above purpose.
16. The successful contractor shall employ sufficient number of labour force to maintain the required rate of progress at the project site.
17. The contractor shall guarantee that all the equipments shall be free from defect due to defective materials and bad workmanship and that the equipment shall operate satisfactorily and the performance and efficiencies of the equipments shall not be less than the guaranteed values. The guarantee shall be valid for a period of 12 months from the date of handing over from the contractor. Any parts found defective during this period shall be replaced free of cost by the contractor. During the guarantee period, the services of the contractor's representatives if requisitioned shall be made available free of cost.
18. The contractor shall during the defects liability period carry out without any extra cost all routine and special maintenance of the equipment and attend to break down calls that may arise in the operation of the equipments. If the defects for the above mentioned reasons are not attended to by the contractor within a reasonable period, BHEL may proceed with the work at contractor's risk and claim the expenses incurred from the contractor. If for any reason the plant is out of operation due to defects for more than one month during the defects liability period, then the defects liability period will get extended by that period of time for which the plant was out of order.
 - a. The guarantee shall cover loss of refrigerant and oil which arises from the defective materials and workmanship.
19. No alterations shall be made by the tenderer in the form of tender or in the tender specifications and schedules. However the tenderer may submit alternate proposals with the complete details including advantages, salient features, design calculations, etc. Acceptance of the alternate proposal rests with BHEL.



DRAWINGS

1. The drawings attached to the specifications are general in nature ,just to describe the scope in brief and cannot be regarded as working drawings. The contractor shall prepare his own detailed working drawings and get them approved by BHEL before execution. Cost of all such drawings, fabrication drawings and details to be furnished by the contractor shall be deemed to be included in the tendered rates for the work.
2. Space allocated for major air conditioning equipment shall be taken into consideration before ordering the equipment and they shall fit into the space provided with required clearances all around as per relevant rules and regulations.
3. Prior to submission for approval, the contractor shall be responsible for thoroughly checking all drawings to ensure that they comply with the intent and the requirement of the contract specifications and that they fit in with the overall building layout.
4. The contractor shall secure the approval of the BHEL for detailed working drawings before proceeding with the works. For this purpose they shall submit 3 sets of drawings. Any alterations proposed by BHEL shall be incorporated in the drawings by the contractor and the corrected drawings shall be submitted once again for approval.
5. The approval of the drawing by BHEL shall not be construed as a complete dimensional check but will indicate that the general method of construction and detailing is satisfactory. The contractor shall be responsible for the dimensions and the design of adequate connections, supports, details, etc and for the satisfactory construction of the work. They shall also bear the extra costs, if any, for all alterations due to discrepancies or omissions in the drawings or other particulars supplied by them, whether such drawings have been approved by BHEL or not.
6. After the installation is completed, 6 sets of “As built drawings” shall be prepared in full incorporating all the changes and submitted to BHEL within one month of the date of completion of installation.

RATES

7. The rates quoted shall be deemed to allow for all minor extras and constructional details which are not specifically shown on the drawings or given in the specifications but are essential for the execution of the works to conform to good workmanship and sound engineering practice. BHEL reserves the right to make any minor changes during the execution without any extra payment.

WORKMANSHIP

8. The successful contractor should coordinate properly for ensuring the best workmanship. In case quality of the works of the contractor is not acceptable, the same shall be redone to the entire satisfaction of BHEL failing which BHEL reserves the right to get the work executed on their own or through other agencies and the expenses incurred will be debited accordingly.



ACCEPTANCE OF EQUIPMENTS / MATERIALS

9. The equipments proposed by the contractor should have proved its performance satisfactorily elsewhere. BHEL has the liberty to obtain more data to judge the performance of the equipment for which the contractor has to render reasonable assistance. The decision of accepting or rejecting the equipments / materials will rest with BHEL and will be binding on the contractor.
10. In case the contractor proposes alternate makes of equipments / materials, they should bring out the salient features and advantages of the same in comparison to the proposed makes of equipments / materials. The decision of BHEL in this regard is final and binding.

TESTING

11. After manufacture of the equipment, all the necessary routine tests shall be carried out as per the relevant standards and as listed in the respective sections. Routine and type tests for the various items of equipment shall be performed at the contractor's/manufacturer's works and test certificates shall be furnished. BHEL may depute their authorised representatives to be present during these tests if they desire to do so. The contractor shall provide all test equipments, labour and other services required for these tests free of cost.
12. Upon notification from the contractor that the installation has been completed, the contractor shall conduct under the direction and in the presence of BHEL's Engineer, tests on the plant as per Performa furnished in the section 'TESTS' in technical specifications. In the event full load due to appliances as specified in design data in technical specifications is not available when the plant is ready for testing and commissioning and/or if the date of test does not coincide with peak summer or monsoon or winter seasons as the case may be, the contractor shall nevertheless conduct tests in the prevailing conditions but shall also repeat them as and when full load due to appliances materializes and during peak seasons during the defects liability period. During such tests, the plant shall be kept running continuously for a period of 48 hours. In case the work does not meet the full intent of the specifications and further tests are considered necessary, the contractor shall bear all expenses thereof.
13. The contractor shall conduct performance tests by keeping the plant running continuously for a period of 48 hours. These tests shall be carried out during all seasons, i.e., summer, monsoon and winter.
14. The contractor shall operate, test and adjust all components as required including the adjustment of all regulating dampers for the purpose of equalising the flow of air to and through all ducts leading to each and every outlet.

OPERATING INSTRUCTIONS

15. The contractor shall furnish a neatly typed set of operating instructions securely framed. These instructions shall include information and guidance on operating pressures, temperatures, air quantities, etc. The contractor shall submit 3 copies of operation and maintenance manuals. Such manuals shall include the equipment catalogues, technical details, wiring diagrams, list of spares, part numbers, etc.



TRAINING OF PERSONNEL

16. The contractor shall train the BHEL's operating and maintenance staff in the operation, repairs and maintenance procedures during installation and maintenance period. Routine operation of the plant for a period of 15 days after putting the plant to beneficial use by the contractor will be done by the BHEL's operating staff along with the contractor's representatives. The contractor shall impart training to the staff during planning, installation, testing and commissioning of the plant also.

BYE – LAWS

17. The contractor shall comply with all bye-laws and regulations of local and other statutory authorities having jurisdiction over the works and shall be responsible for the payment of all fees and other charges and the giving and receiving of all necessary notices and keep BHEL informed of the said compliance with the bye-laws, payments made, notices issued and received.
18. The contractor shall indemnify BHEL against all claims in respect of patent rights, design, trademarks or name or other protected rights in respect of any plant, machine, work or material used for or in connection with the works or temporary works and from and against all claims, demands, proceedings, damages costs, charges and expenses whatsoever in respect thereof or in relation thereto. The contractor shall defend all actions arising from such claims and shall himself pay all royalties, license fees, damages, cost and charges of all and every sort that may be legally incurred in respect thereof.

WORKS AT SITE

19. Access to the works site shall be allowed only to the contractor or his duly appointed representatives. The contractor shall not object to the execution of the work by other contractors or labourers and shall afford them every facility for execution of their works. Work at BHEL's premises shall be carried out at such times as approved by BHEL. The contractor shall take all safety precautions to ensure safety of properties and life at site. The contractor shall obey central, local and state regulations and enactments pertaining to workmen and labour and BHEL shall have the right to enquire into the matter and decide all complaints on such matters.

TAKING OVER

20. The works when completed at site shall be deemed to have been taken over by BHEL when it is certified in writing that the plant has fulfilled the contract conditions

CLEARING OF SITE

21. On or before the scheduled date of completion, the site shall be cleared and handed over in a perfect condition. Till this date the contractor is liable for all expenses, damages and thefts which may occur at the site. The work damaged or destroyed before finally being taken over by BHEL either through the negligence of the contractor or carelessness of the subcontractors or representatives shall be rebuilt by the contractor at his cost or shall be rectified by BHEL



and the costs incurred shall be debited to the contractor.

STANDARDS

22. Wherever reference has been made to various standards in the technical specifications, the latest version of the same at the time of tendering shall be applicable.

WORKS TO BE DONE BY THE TENDERER

23. The tenderer shall include the following works along with the other works specified in the tender:

- a) All foundation bolts, vibration isolation pads, etc for the equipments, MS framework / foundation for the outdoor air cooled condensers of the a/c units.
- b) Providing supports for all pipes, ducts, cables, cable trays, etc.
- c) Providing drain piping for the packaged a/c units up to a point where it can be lead out.
- d) Painting of all supply air return air grilles, diffusers, etc., to match with the interior decor.
- e) All minor civil works such as breaking and making good of openings in walls / ceilings / floors for the passage of pipes, cables, wires, etc.
- f) Any other works connected with the air conditioning system, which is deemed to have been included in the scope of this contract to ensure satisfactory performance of the plant.

WORKS TO BE CARRIED OUT BY BHEL / OTHER AGENCIES

24. The following works shall be done by BHEL and / or by other agencies:

- a) Provision of 3 phase power supply of required capacity along with earthing in the AC plant room of required capacity and rating.

LIST OF SIMILAR INSTALLATIONS

25. The tenderer shall bring out specifically in the tender about his set up available in Bangalore for execution of the project. He shall also bring out the list of similar installations carried out.

POST WARRANTY MAINTENANCE

26. The tenderer shall quote separately rates for post warranty maintenance of the plant on comprehensive basis inclusive of materials and labour. Alternatively they shall also quote only on labour basis, in which case they shall indicate the list of spares to be arranged by the owner and their availability.



EQUIPMENT SPECIFICATIONS

1. DIRECT EXAPNSIONAIR HANDLING UNITS (DX-AHUs)

The housing of DX air handling units shall be double skinned type of min 25 mm thick panel. The panel of the housing shall be fabricated out of of 0.6mm pre-coated/pre-plasticized galvanised steel inner and outer skin with CFC free PUF insulation of density 38KG/M3 injected in between inner and outer skin. The panels shall be screwed on to frame work of Extruded Aluminium type sections. The AHU shall be equipped with Backward Curved DIDW type centrifugal fan of (Nicotra/Kruger) make. The wheel and housing shall be made of heavy gauge galvanised steel. The fan shall be selected for a noise level less than 85db(A) and it shall be statically and dynamically balanced.

The AHU shall have Direct Expansion heat exchanger with Thermostatic Expansion valve. The Heat exchanger will be finned heat exchanger consisting of minimum 6 rows copper tube and Aluminium fins. The tubes shall be of 12.5 to 15 mm diameter of minimum 0.4/0.5 mm thick wall with Aluminium fins firmly bonded to copper tubes assembled in Galvanised/Stainless steel frame. The coil shall be factory tested at a pressure of 21 Kg/Sq.cm air pressure under water.

The fan motor shall be TEFC with IP-55 protection and shall be suitable for operation on 415 +/- 10% V, 3 phase, 50Hz power supply. Drive to fan shall be provided through Belt Drive arrangement.

The AHU shall have condensate drain pan from 18 Gauge stainless steel with all corners welded. It shall be provided with proper slope and insulated with Nitrile rubber.

Pre-Filter with efficiency 90% down to 10 microns shall be provided. The filters shall be synthetic washable type. Proper arrangement of illumination may be provided for inside the AHU.

Test certificates shall be furnished for Air Handling Units. BHEL may depute their authorized representatives to witness the tests at the factory if so desired.

2. Condensing Units(ODUs)

The condensing units shall be air cooled type with scroll compressor(S) and condenser coil and fans. The casing of outdoor units shall be fabricated out of heavy gauge hot dip galvanized steel sheets and shall be fixed properly and rigidly. The units shall be treated for corrosion resistance and powder coated / painted finish.

The compressor shall be hermetic/ semi-hermetic scroll type of Danfoss make, suitable for use with R-134A /410A/407C(Eco-Friendly Refrigerant). It shall be complete with suction and discharge shut off valves, crank case heater, controls such as HP/LP cut-out and oil pressure failure switch.

The condenser coil shall be made out of copper tubes and aluminium fins. The coils shall be sized so as to optimise performance with respect to air flow rate, pressure drop, condensing temperature, power consumption etc. The condenser fans shall be of propeller type, statically and dynamically balanced. The fan motor shall have IP-55 protection and shall be suitable for outdoor installation.

Provision in the condensing units shall be made for integrating with microprocessor based controller. On failure and resumption of power supply, the units shall restart automatically. The units shall be suitable for operation on 415 +/-10% V, 3 phase, 50Hz power supply. Test certificates shall be furnished for the packaged units. BHEL may depute their authorized representatives to witness the tests at the factory if so desired.



3. SHEET METAL WORK

The scope of this section comprises supply fabrication, installation and testing of all sheet metal ducts, supply, installation, testing and balancing of all diffusers. All sheet metal ducting shall be fabricated as per IS 655:2006(Air duct specification) from galvanised steel sheet conforming to IS: 277. The zinc coating in the sheets shall conform to class VI. Flanges and stiffeners used in duct sections shall be rolled steel angles / flats. All bolts, nuts and washers shall be of zinc plated steel and all rivets shall be galvanised or made of aluminium alloy. 3 mm thick neoprene rubber gaskets shall be used at the duct joints and the same shall be leak proof. Only new, clean unsoiled and bright sheets shall be used. BHEL reserves the right to reject the sheets not meeting the above requirements.

A. Plenum Duct

The plenum duct shall be of rectangular type. All ducts shall be fabricated from galvanized steel sheets of the following thickness as indicated in Schedule of Quantities.

	G S S	ALUMINIUM
Rectangular ducts upto 750 mm	24 gauge	22 gauge
Rectangular ducts 760 to 1500 mm and all round ducts.	22 gauge	20 gauge
Rectangular ducts 1501 to 2250 mm	20 gauge	18 gauge
Rectangular ducts greater the 225 cm	18 gauge	16 gauge

B. SPIRAL/ELLIPTICAL DUCTING (WITHIN AIR-CONDITIONED SPACE)

Ducting inside the air conditioned area shall be factory fabricated pre-painted spiral/elliptical ducts and duct fittings (bends, reducers, tees, branch collars, off sets, flanges and end caps) and supporting clamps at 2.0 mtrs spacing. All ducts shall be fabricated from galvanized steel sheets of the following thickness as indicated in Schedule of Quantities.

Diameter (mm)	Thickness mm (Gauge)
75 to 250	0.40 (28 G)
251 to 350	0.50 (26 G)
351 to 600	0.63 (24 G)
601 to 900	0.80 (22 G)
901 to 1250	1.00 (20 G)

C. DAMPERS

- i. Dampers: All duct dampers shall be opposed blade louver dampers of robust 16 G GSS construction and tight fitting. The design, method of handling and control shall be suitable for the location and service required.
- ii. Dampers shall be provided with suitable links levers and quadrants as required for their proper operation. Control or setting device shall be made robust, easily operable and accessible through suitable access door in the duct. Every damper shall have an indicating



- device clearly showing the damper position at all times.
- iii. Dampers shall be placed in ducts at every branch supply or return air duct connection for the proper volume control and balancing of the air distribution system.
- D. All angles, rods and other MS members, materials etc., used for supports shall be provided with a coat of red oxide primer, both before and after being placed in position.
- E. All duct Joints shall be made air tight by provision of necessary gaskets and all interior surfaces shall be smooth. Bends shall be made with radius not less than one half the width of the duct or with properly designed inside curved vanes. Turning vanes shall be provided at all branch take-offs and collars wherever applicable.
- F. Volume control dampers shall be provided in the branch ducts for the purpose of air balancing. Suitable links, levers and quadrants shall be provided for proper operation and setting of the dampers. The dampers shall have provision to indicate clearly the damper position at all the times.
- G. Main branch which will be entering insides the catering area shall be provided with Fire dampers which will be of louver type complete with fusible links and shall be provided as required.
- H. Duct connections to the evaporator units shall be made by inserting 100 mm flexible double canvass.
- I. Where sheet metal ducts or sleeves terminate in wood work, brick or masonry openings, tight joints shall be made by means of closely fitted heavy flanged collars.
- J. All air outlets, air intakes and accessories shall be made out of either MS or aluminium as indicated in the bill of quantities. A sample of each type of air outlet or intake shall be submitted for approval and the same shall be kept at the site.
- K. All supply air grilles shall be of double deflection type with both horizontal and vertical vanes being adjustable. The supply air grilles shall be provided with volume control multilouvre dampers which shall be key operated from the front of the grilles.
- L. The return air grilles where employed shall have only horizontal louvers and these shall be fixed.
- M. After installation, the entire ducts shall be tested for leaks. The air distribution system shall be balanced using an anemometer. Air quantities measured after balancing shall be within 5 % of the specified Air quantities. The position of various dampers shall be permanently marked after completion of air balancing to ensure the correct position even if disturbed later.

4. REFRIGERANT PIPING

This section describes the general requirements for the design, supply, installation and testing of the refrigerant piping involved in this project.

1. Refrigerant piping shall be made out of hard drawn copper or soft copper tubing. Copper pipes shall be used for hermetic/semi hermetic compressors.



2. All pipes shall be new, fresh and clean. Dirt/muck inside the pipes shall be flushed out before laying.
3. Refrigerant piping shall be sized in such a way that due consideration of inter-distance between Dx-AHUs and condensing units may be taken care of as per relevant Indian/International standard of the same.
4. Copper pipes shall be brazed using brazing alloy of silver-copper-phosphorous type and shall be made by the flow of brazing alloy by capillary action along the annular space between the two mating surfaces. Jointing between two MS tubes or MS tube and fitting shall be done by electric arc welding. MS tubing shall be cut to form proper 'V' at the mating ends before welding. Gas flame shall not be used for this purpose.
5. Refrigerant pipe lines shall be properly designed to ensure proper oil return and avoid slope over into the compressors. The pipes shall be supported properly and should be able to withstand the thermal stresses and vibrations encountered during normal operations.
6. The system shall include refrigerant controls such as thermostatic expansion valves, pilot solenoid valve and system components such as liquid strainers, liquid moisture indicators, purge relief and charging valves.
7. While installing the piping, adequate clearance shall be provided for insulation wherever insulation is required.
8. Refrigerant pipe/tube ends shall be kept plugged or kept closed at all times before installation at site, to prevent ingress of moisture and foreign matters. Piping supports shall not be spaced more than 2000 mm apart and substantial enough to prevent bending stresses.
9. On completion of erection, the pipes shall be pressure tested with dry nitrogen or carbon-dioxide. The test pressures shall be as under.
 - a. High pressure side 25 kg / sqcm
 - b. Low pressure side 10.5 kg / sqcm
10. All joints shall be tested for leakages with soap solution. Leaks shall be marked, pressure released and rectified. System shall be recharged and tested till all leaks are arrested. Pressure gauges and controls may be valved off during pressure testing.
11. Upon completion of pressure testing, vaccumising shall be carried out with a two stage rotary vane vacuum pump connected to both the high and low sides of the system. Vacuum pump shall be operated to reduce the pressure to 500 microns absolute and allowed to operate at this pressure for 8 hours. Vacuum shall then be broken with a mixture of dry nitrogen and a small quantity of refrigerant and re vacuumised. The vacuum achieved shall be at least as deep as 500| microns and shall be maintained for a period of at least 24 hours after the vacuum pump has been shut off. After ensuring that there are no leaks, correct quantity of refrigerant gas shall be charged.
12. No insulation shall be applied to pipes unless the pressure testing is completed to the satisfaction of BHEL. Insulation shall be done for the suction line and Liquid after the plant has been run for about 48 hours.
13. BHEL shall be notified well in advance by the contractor of his intention to test piping and all



testing shall be witnessed by the authorised representatives. Further, test certificates duly signed by the contractor and BHEL representatives shall be submitted after completion of the tests.

14. Refrigerant lines shall be given 2 coats of enamel paint before placing insulation.

5. INSULATION WORK

The scope of this section comprises the supply and application of insulation to refrigerant piping, sheet metal ducting, walls and ceiling.

1. All ducts which is exposed to ambience shall be insulated with Nitrile rubber insulation with Aluminium foil on exposed surface .The thickness of insulation shall not be less than 18 mm for supply air and 12 mm for return air.
2. All the copper pipes suction as well as liquid lines shall be provided with nitrile rubber insulation of suitable thickness.
3. All insulation on equipment and piping shall be applied only after the system has been pressure tested.
4. Plenum shall be provided with 25 mm thick resin bolded fibre glass minimum 32 Kg/m³ (inside the ducts) for acoustic lining. The insulation shall be covered with 26 G perforated aluminium sheet having at least 10% perforations and fixed using GI bolts, nuts and plate washers.
5. BHEL's authorised representatives reserve the right to check the weights, dimensions, etc., of the insulation material supplied. The successful contractor shall submit samples of different types of insulation material specified. BHEL shall have the right to reject all materials which do not conform to the specifications.

6. CONTROL PANEL

This section covers specifications for the supply, installation, testing and commissioning of the wall mounted microprocessor based control panel and instruments and supply, installation, testing and commissioning of Control cables as per tender schedule. The control panel shall be facilitated with following feature.

- 1) Safety controls such as high / low pressure cut-outs, oil pressure failure switch, external overload relay, single phasing preventer, under voltage relay, and inbuilt thermal protection for compressor shall be provided.
- 2) The control panel shall be equipped with starters. The motor starter shall conform to IS:1622 and shall be totally enclosed and dust proof DOL starters shall be used for squirrel cage induction motors up to 7.5 HP and star delta starters for motors of capacity 7.5 HP and above.
- 3) The starters shall be provided with thermal overload relay with built in single phasing protection. If mentioned specifically, voltage sensing single phasing preventer and under/over voltage protection shall be provided



- 4) Thermostat shall be provided for automatic switching on and off of the air conditioning units.
- 5) The control panel of a/c units shall have electronic control cum annunciation panel with digital display indication and safety features.
- 6) The DX a/c units shall have provision to be electrically interlocked with the fire fighting system by which the entire air conditioning system gets switched off automatically in case of fire in any zones.
- 7) All control wiring between Control panel, AHUs, Condensing units shall be done with armoured XLPE copper cable 1.5 sq mm 6 core.
- 8) All automatic controls and instruments shall be factory calibrated and provided with necessary instructions for site calibration and testing. These shall be tested for accuracy and reliability at the site as required.

7. ELECTRICAL WORK

The scope of this section comprises of fabrication, supply, erection, testing and commissioning of electrical control panel, wiring and earthing/grounding of all air conditioning equipments. The electrical equipments shall be suitable for operation on $415V \pm 10\%$, 50 Hz, earthed neutral, three / single phase AC supply. The entire electrical installation shall conform in all respects to the latest relevant Indian Standards. The detailed specification for electrical work shall comprise of the following .

1. The panel shall be made of 14 SWG sheet steel for frames & front and Back Doors and the enclosure (Internal partitions and end sheets) shall be made of 16 SWG Sheet steel and shall be compartmentalized. The enclosure along with frame shall be pre-treated (Phosphate) and powder coated. The colour of the panel shall be as per Engineer-In charge's choice.
2. All the Bus-Bar shall be of Aluminium and shall be mounted with proper insulator mount.
3. The panel shall have one incomer compartment with 315 Amps SDFU, one metering compartment and four compartment with 125 Amps SDFU.
4. The metering compartment shall be provided with one Digital Multifunction meter with selector switches and all other four compartments shall be equipped with Analog Ammeter with selector switches.
5. The metering compartment shall be provided with indicating lamps for R, Y, B phases. And all four compartment with 125 Amps shall be provided with indication lamps for unit on/off indication.

POWER WIRING / CABLING

6. 4 core PVC insulated sheathed armoured cables having Voltage Grade 1100/6600 volts and conforming to IS 1554 shall be used for connecting various three phase motors in the system to the main electrical panel board.
7. The sizing and selection of cables shall be made taking into consideration the maximum rating current of the equipment, permissible voltage drop, ambient temperatures and the applicable derating factors.



8. Cabling shall be laid in cable trays suspended with hangers. Cables shall be terminated using glands with al. cable sockets.
9. For current requirements up to 400 A, 2 nos. GI earth electrodes shall be used. No earth electrode shall have ohmic resistance of more than 5 ohms.
10. Earth lead of GI/copper wire/strip shall be taken from the main earth station and shall be of adequate cross section. Earth leads laid underground shall be drawn through GI pipes to protect against mechanical damages.

MOTORS

11. The motors shall be squirrel cage Totally Enclosed Fan Cooled (TEFC) or Screen Protected Drip proof (SPDP) type with minimum class B insulation. Terminals shall be amply sized and housed in a terminal box which shall be suitable for cable or conduit entry. Two earthing terminals shall be provided. The motor shall have suitable starting torque. Motors shall be suitable for $415V \pm 10\%$, 3phase, 50 cycles AC supply. Motors shall conform to IS:325.

8. MEASUREMENTS

The following procedures for measurements shall be adopted for variable items.

DUCTING & DUCT INSULATION

- 1) Ducting shall be measured on the external surface area. The unit rate per sqm of external surface shall include flanges, bolts, nuts, gaskets, duct supports, anchor fasteners, vanes, splitter dampers and painting. Duct measurements shall be taken before application of insulation.
- 2) The area of duct insulation shall be the same as the area the uninsulated ducts.
- 3) Grilles, diffusers and dampers shall be measured on the cross sectional area basis excluding flanges.

PIPING & PIPING INSULATION

- 4) Piping shall be measured on linear basis and shall include all fittings, flanges, unions, gaskets, bolts, nuts, pipe supports, flexible connections, vibration isolators, painting and piping insulation. One Rmt of BOQ shall be construed as one meter of suction line and one meter of liquid line along with insulation taken together.

Cables(Power/Control)

- 5) All cables shall measure on linear basis from outside of the panel to equipment. And it shall include all fitting like termination, glands etc.



9. TESTS

The following readings shall be taken during the testing of the plant. All instruments required for testing shall be provided by the contractor. The readings shall be taken in the presence of the BHEL representatives and duly signed by all concerned. A copy of the test readings along with detailed calculations for capacities shall be submitted.

Ambient Air Conditions

Dry bulb temperature	deg C
wet bulb temperature	deg C
Relative humidity	%

Inside Conditions

Dry bulb temperature	deg C
Wet bulb temperature	deg C
Relative humidity	%

GRILLE LEAVING TEMPERATURE

Dry bulb temperature	deg C
wet bulb temperature	deg C
Relative humidity	%
Air Volume through each grille	cfm



16.0 LIST OF APPROVED MAKES FOR EQUIPMENT & MATERIAL

Only approved makes for different materials / equipments as given below shall be used for this air conditioning work. No other make shall be accepted. Any make listed below but not conforming to Technical Specs/ Standards prescribed in the Tender shall not be accepted.

Details of Materials / Equipment Make	Make (Manufacturer's Name)
DX AHUs	: Voltas, Blue star, ETA, Systemair, Edgetech ,Zeco.
Condensing units	: Voltas, Blue star, ETA, LG, Clivet, Daikin.
GI sheets	: SAIL, Nippon Denro(JSW), Jindal
Aluminium grilles	: Airmaster, Dynamic, Opela, Tanus
Pipe Insulation	: Vidoflex, Insulflex, Superlon, Supreme,K-flex
Dampers	: Airmaster, Ravi Star, Dynamic, Humidin
Duct insulation	: Vidoflex, Insulflex, Superlon, Supreme,K-flex
Contactors, Overload relays	: L&T, Siemens, Crompton, BCH
Push buttons & P.B.stations	: L&T, Siemens, Crompton, BCH
Single phasing preventers	: L&T, Siemens, Crompton
Earth leakage relays	: Prok devices
Under/over voltage protection	: Prok devices
LT current transformers	: Kappa, TELK, Indcoil
Voltmeters, Ammeters	: MECO, Toshniwal, Auto Elec, IMP
Selector switches	: Kaycee, Thaker, Switchon
Indicating lamps	: Siemens, Vaishnov
Switches / Switch disconnectors	: L&T / EE / seeders / GEC
Units / Isolators	
MCBs	: MDS
Cables	: CCI, ICC, Universal, Fort, glosser, Asian, NICCO, Premier
PVC insulated copper wires	: Finolex, Wincap,Anchor,Skystone
Cable trays	: MEK / Indiana
Conduit pipes & accessories	: GB / BI
Motors	: BHEL, Siemens, Kirloskar, ABB, Crompton, AEI

NOTE:

Contractors intending to supply other makes of materials than those listed above , shall indicate the makes considered in their offers highlighting the salient features and advantages of the same along with the catalogues. The right of accepting such alternate makes rests with the customers .

Drawing of the Proposed Arrangements of Equipments

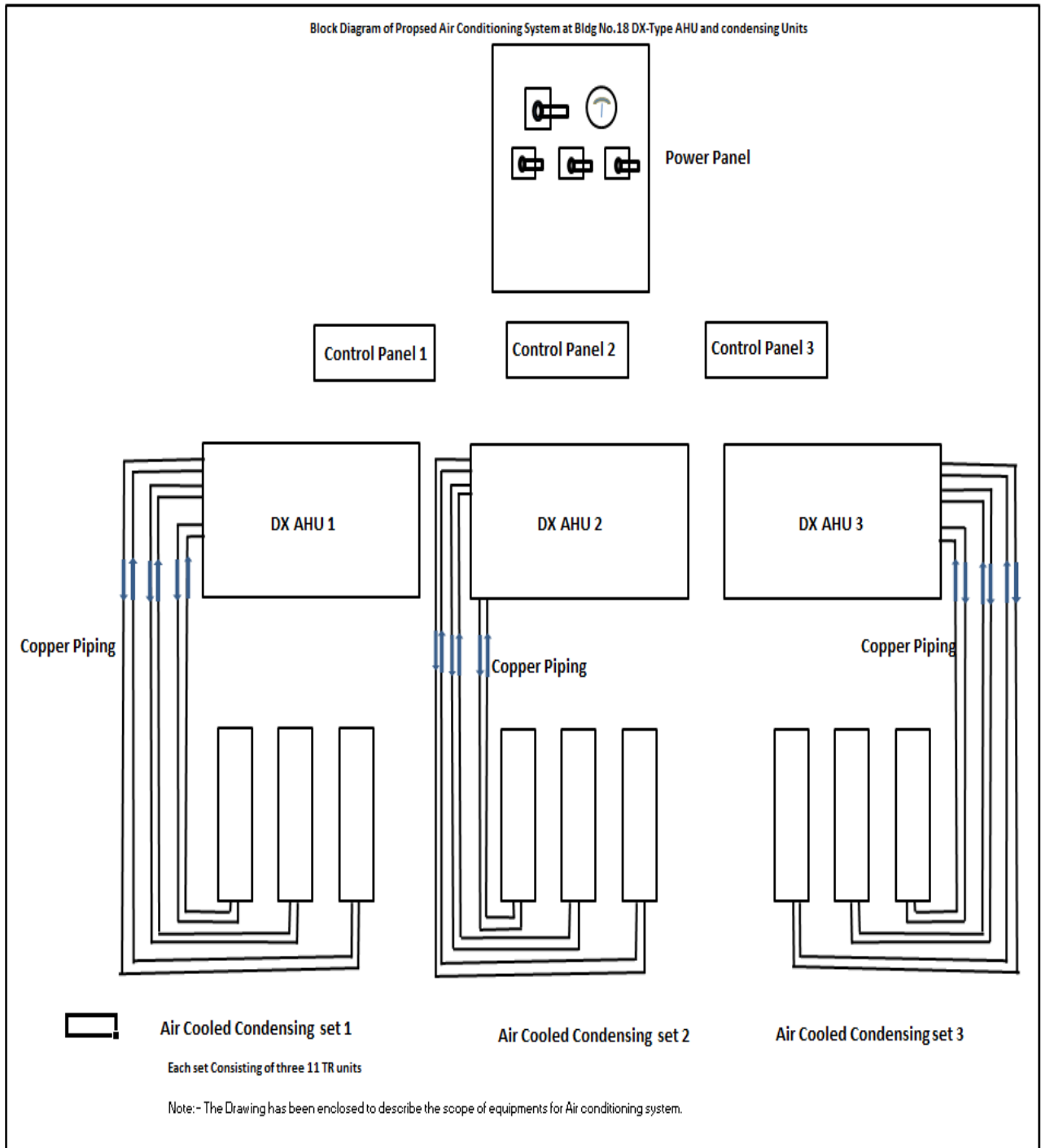

Drawing of Tentative Arrangement of Duct inside the catering area

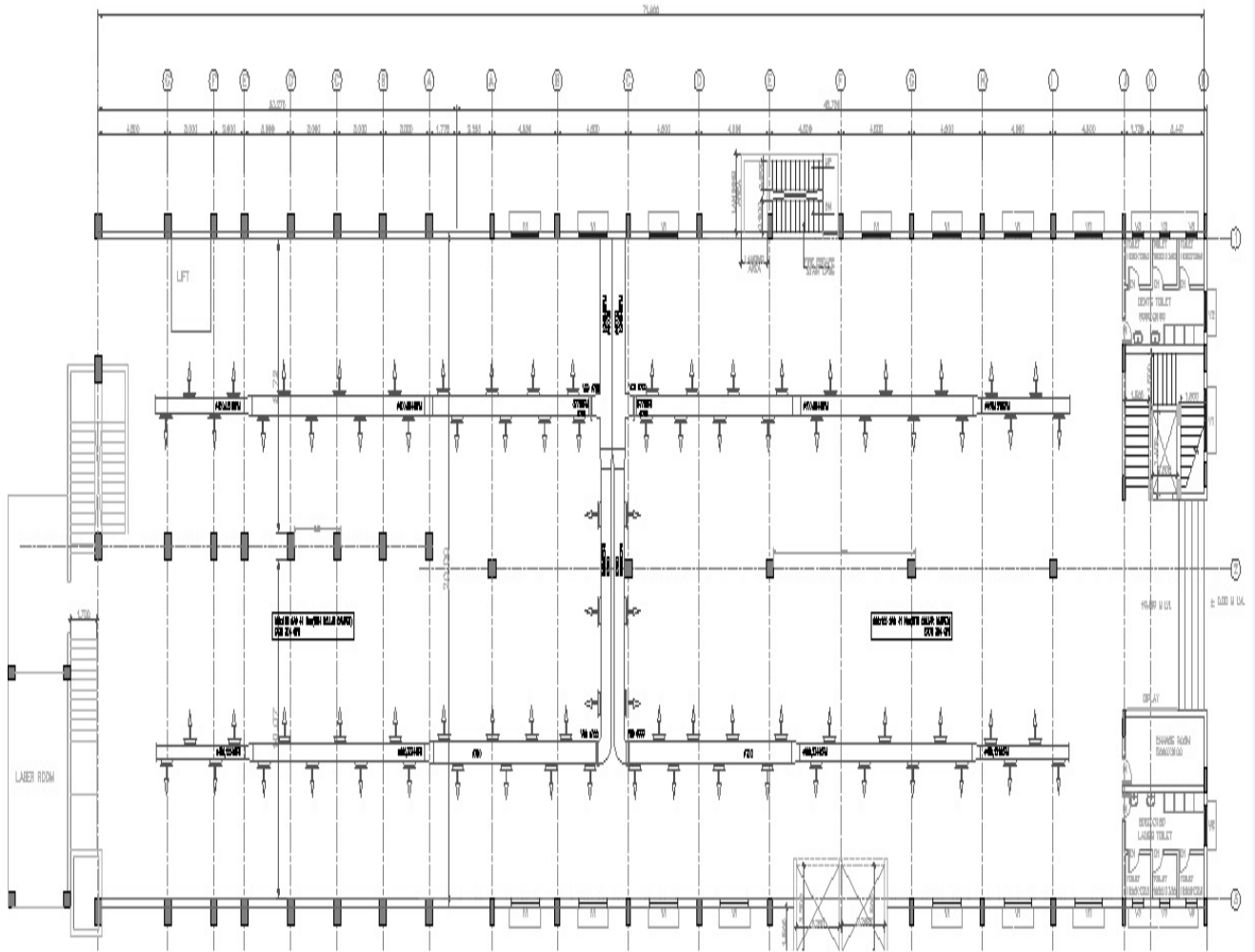



LIST OF INDIAN STANDARD

I.S. 325	-	-	Three phase induction Motors.
I.S. 1822	-	-	Motor starters of voltage not exceeding 1000 volts
I.S. 996	-	-	Single phase small A.C. and universal motors.
I.S. 277	-	-	Galvanized steel sheets.
I.S. 655	-	-	Metal Air ducts.
I.S. 900	-	-	Code of practice for installation and maintenance of induction motors.
I.S. 2208	-	-	HRC cartridge fuse-links upto 650 volts.
I.S. 1554 (I)	-	-	PVC insulated (heavy duty) Electric cables for working voltage upto and including 1100 volts.



APPENDIX - III

I.S. SAFETY CODES

I.S. 660	-	-	-	Safety code for mechanical refrigeration.
I.S. 659	-	-	-	Safety code for air conditioning
I.S. 3016	-	-	-	Code of practice for fire precautions in welding and cutting operations.
I.S. 818	-	-	-	Code of practice for safety and Health requirements in electrical & gas welding and cutting operations.
I.S.5216	-	-	-	Code for safety procedures and practices in Electrical works.
I.S. 3696	-	-	-	Safety code for scaffolds and ladders.



TECHNICAL DATA

DX- AHUs

Make	:
Model	:
Total Air quantity(CFM)	:
Static pressure at Outlet (MM of water column)	:
Cooling Capacity in TR	:
Material of Housing(Sheet)	:
Thickness of Housing Panel	:
Expansion Valve	:
Rows of Tubes (In Evaporator)	:
Material of Tubes	:
Material of Fins	:
Dia & Thickness of Tubes	:
Electrical Characteristics (415±10% V, 3φ, 50Hz)	:
Class of Insulation	:
Motor Protection	:
Motor rating	:
Mode of starting	:
Make of Fan	:
Material of Fan	:
Whether statically and dynamically balanced.	:
Size and no. of pre-filters	:
Arrestance and efficiency	:
Noise Level (dB)	:

CONDENSING UNITS

Manufacturer	:
Model	:
No. of compressors per machine	:
Type of compressor	:
Operating speed RPM	:
Capacity at 4.4 deg C suction and 54.5 deg C condensing temp – TR	:
Power consumed at the above conditions	:
Type of lubrication	:
Range of working voltage & frequency	:
Class of protection	:
Weight	:
Type of starter	:
AIRCOOLED CONDENSER FAN	:



Total air quantity - cum/hr :
No. of fans :
Type of fan :
Make of fan :
Fan diameter mm :
Fan speed RPM :
Fan motor kw :
No. of fan blades :
Material of blade and hub :
Type of motor :
Degree of motor protection :
Whether statically and dynamically :
balanced. :
Type of power supply 1 or 3 phase :

CONTROLS

HP / LP cutout : Yes / No
Oil pressure failure switch : Yes / No
Overload relay : Yes / No
Over/under voltage relay : Yes / No
Time delay relay : Yes / No
Inbuilt compressor protection : Yes / No
Microprocessor based control : Yes / No

DIMENSIONS

DX AHU UNIT

Width (mm) :
Depth (mm) :
Height (mm) :
Weight. (kg) :

OUTDOOR UNIT

width (mm) :
Depth (mm) :
Height. (mm) :
Weight (kg) :

DUCTING

Make of GI sheets :
Class / Grade :

GRILLES / DIFFUSERS

Make/ Material of construction :

DAMPERS

Make :
Material of construction :
Type of blades - parallel / opposed :



ANNEXURE-II

Questionnaire

Questionnaire to be answered by the tenderer by ticking the suitable boxes

S.No.	Description	Yes	No
01	Whether the tenderer has understood the scope of work as indicated in the tender. (If there is any clarification required, the same may be got cleared from the Executive in charge, before submitting the offer.)		
02	Whether the tenderer has agreed to all terms and Conditions given in the tender. (If there is any deviation, the same may be mentioned in separate sheet.)		
03	Whether the tenderer agrees for the payment terms mentioned in the tender.		
04	Whether the tenderer has their own code for ESI and PF. (If the tenderer does not possess whether the tenderer has agreed to obtain ESI/PF code before commencement of the work).		
05	Whether the tenderer agrees to comply with all statutory regulation.		
06	Whether the tenderer agrees to give validity of offer for 3 months from the date of opening of technical bid.		
07	Whether the tenderer agrees to company with all safety Standards as mentioned in the tender specification.		
08	Whether the tenderer has agreed to submit EMD of Rs. 1,00,000/- (Rupees One lakh only) and has submitted the same along with technical bid. (If not enclosed, the tender will not be considered.)		
09	Whether the tenderer has service Tax registration No. (If they do not have the same, the offer will not be considered.)		
10	Whether the tenderer has agreed to submit Security Deposit immediately after receipt of the work order as mentioned in the tender.		
11	Whether the tenderer has enclosed the list of clients with addresses and contact person.		
12	Whether the tenderer has enclosed the list of similar works already done / being done with the addresses and contact person.		



S.No.	Description	Yes	No
13	Whether the tenderer has enclosed the certificates received from Government / Reputed organization for the similar work done.		
14	Whether the tenderer has enclosed the list of technical personnel their qualification and experience who will be in charge for this work.		
15	Whether the tenderer has indicated the address of their local offer in Bangalore along with the phone no. & fax no. etc.		
16	Whether the tenderer has enclosed the solvency certificate obtained from a bank for a value not less than 30% of estimated cost of the work.		
17	Whether the tenderer has enclosed the copy of Power of Attorney (if applicable)		
18	Whether the tenderer has enclosed the certificate to establish that the tenderer is an independent contractor working on his own.		
19	Whether the tenderer has agreed to supply materials as per the Approved makes as mentioned in the tender.		
20	Whether tenderer has agreed to insure all supplying materials and his labours.		
21	Whether tenderer has enclosed the copy of PAN No.		

Note : If any of the question is not applicable, please mention as “Not Applicable”



ANEXURE: 'A'

**Electronic Funds Transfer (EFT) OR
 Paylink Direct Credit Form**

Please Fill up the form in **CAPITAL LETTERS** only.

TYPE OF REQUEST(Tick one): _____ CREATE _____ CHANGE

BHEL Vendor / Supplier Code:	<input type="text"/>
Company Name :	<input type="text"/>
Permanent Account Number(PAN):	<input type="text"/>
Address	<input type="text"/>
	<input type="text"/>
	<input type="text"/>

City:	<input type="text"/>	PINCODE	<input type="text"/>	STATE	<input type="text"/>
-------	----------------------	---------	----------------------	-------	----------------------

Contact Person(s)	<input type="text"/>
Telephone No:	<input type="text"/>
Fax No:	<input type="text"/>
e-mail id:	<input type="text"/>

1 Bank Name:	<input type="text"/>
2 Bank Address:	<input type="text"/>
	<input type="text"/>
	<input type="text"/>

3 Bank Telephone No:	<input type="text"/>
4 Bank Account No:	<input type="text"/>
5 Account Type: Savings/Cash Credit	<input type="text"/>
6 9 Digit Code Number of Bank and branch appearing on MICR cheque issued by Bank	<input type="text"/>
7 Bank swift Code(applicable for EFT only)	<input type="text"/>
8 Bank IFSC code(applicable for RTGS)	<input type="text"/>
9 Bank IFSC code(applicable for NEFT)	<input type="text"/>

A I hereby certify that the particulars given above are true, correct and complete and that I, as a representative for the above named Company, hereby authorise BHEL, EDN, Bangalore to electronically deposit payments to the designated bank account.

B If the transaction is delayed or not effected at all for reasons of incomplete or incorrect information, I would not hold BHEL / transferring Bank responsible.

C This authority remains in full force until BHEL, EDN; Bangalore receives written notification requesting a change or cancellation.



I have read the contents of the covering letter and agree to discharge the responsibility expected of me as a participant under ECS / EFT.

Date:

Authorised Signatory:
Designation:

Telephone NO. with STD Code

Company Seal

Bank Certificate

We certify that _____ has an Account No _____ with us and we confirm that the bank details given above are correct as per our records.

Date:
Place

(.....)
Signature

Please return completed form along with a blank cancelled cheque or photocopy thereof to:
Bharat Heavy Electricals Ltd,
Attn:
Electronics Division, Mysore Road,
BANGALORE - 560 026
In case of any Query, please call : 080-26998406 / 26989192 or fax no. 080-26989217



ANEXURE: 'B'

GENERAL CONDITIONS OF CONTRACT

It is hereby agreed by me/us that the BHEL General Conditions of Contract including subsequent amendments/ additions/ deletions to clauses if any, and conditions pertaining to the settlement of disputes by Arbitration form an integral part of the tender documents and that the tender submitted by me / us is subject to the aforesaid BHEL General Conditions of Contract which has been read and accepted by me/us.



ANNEXURE 'C'

CLAUSE 20 OF GENERAL CONDITIONS OF CONTRACT

LABOUR

The Contractor shall employ labour in sufficient numbers either directly or through sub-contractors to maintain the required date of progress and of quality to ensure workmanship to the degree specified in the contract and to the satisfaction of the Engineer-in-charge. The contractor shall not employ, in connection with the works, any person who has not completed eighteen years of age.

The Contractor shall furnish to the Engineer-in-charge, at the intervals specified by him, a distribution return of the number and description by trades of the work people employed on the works. The Contractor shall also submit on the 4th and 19th of every month to the Engineer-in-charge a true statement showing in respect of the second half of the preceding month and the first half of the current month (i) the accidents that occurred during the said fortnight showing the circumstances under which they happened and the extent of damage and injury caused by them and (ii) the number of female workers who have been allowed maternity benefits as provided in the Maternity Benefit Act, 1961 or Rules made there under and the amount paid to them.

liquidated damages for every default, breach, or furnishing, making, submitting, filling materially incorrect statements as may be fixed by the Engineer The Contractor shall pay to labour employed by him, either directly or through sub-contractors, wages not less than fair wages, as defined in the Contractor's Labour Regulations.

The Contractor shall in respect of labour employed by him, either directly or through sub-contractors, comply with or cause to be complied with contractor's labour Regulations in regard to all matters provided therein.

The Contractor shall comply with the provisions of the payment of Wages Act, 1936, Minimum Wages Act, 1948, Workmen's Compensation Act 1923, Industrial Disputes Act, 1947, Maternity Benefit Act 1961, or any modifications thereof or any other law relating there to and rules made thereunder from time to time.

The Contractor shall be liable to pay his contribution and the employees' contribution of the State Insurance Scheme in respect of all labour employed by him for the execution of the contract, in accordance with the provision of "The Employees' State Insurance Act, 1948," as amended from time to time. The Contractor shall apply to the ESI Authorities, get himself registered with them and obtain a code Number. He shall pay the remittances under his Code Number only.

The Contractor shall be liable to his contribution and the employees contribution towards PF as per Provident Fund Rules and Regulations, in respect of all labour employed by him for the execution of the contract. The Contractor shall apply to the PF Authorities, get himself registered and obtain a code number from them. He shall pay the remittances towards PF under his code number only.



The Engineer-in-charge shall, on a report having been made by an Inspecting Officer as defined in the Contractor's Labour Regulations, have the power to deduct from the moneys due to the contractor any sum required or estimated to be required, for making good the loss suffered by a worker or workers by reason of non fulfillment of the conditions of the contract for the benefit of workers, non-payment of wages or of deductions made from his or their wages which are not justified by the terms of the Contract of non observance of the said Contractor's Labour Regulations.

The Contractor shall indemnify BHEL against any payment to be made under and for observance of the Regulations aforesaid without prejudice to his right to claim indemnity from his sub-contractors.

In the event of the Contractor committing a default or breach of any of the provisions of the aforesaid contractor's Labour Regulations, as amended from time to time or furnishing any information or submitting or filling any form / Register / Slip under the provisions of these Regulations which is materially incorrect, then, on the report of the Inspecting Officers as defined in the Contractors Labour Regulations, the Contractor shall without prejudice to any other liability pay to BHEL a sum not exceeding Rs. 50/- as – In – Charge and in the event of the contractor's default continuing in this respect, the liquidated damages may be enhanced to Rs. 50/- per day for each day of default subject to a maximum percent of the estimated cost of works put to tender. The Contractor shall defend the case by himself any action brought in by such Government Agencies for non-compliance of any Labour Regulations and / or reimburse the expenses incurred by BHEL in this regard.

The Engineer-in-charge shall deduct such amount from bills or security deposit of the Contractor and credit the same to the welfare fund constituted under Regulations. The decisions of the Engineer-in-charge in this respect shall be final and binding.

MODEL RULES FOR LABOUR WELFARE

The Contractor shall, at his own expense, comply with or cause to be complied with Model Rules for Labour Welfare as appended to these conditions or rules framed by Government from time to time, for the protection of health and for making sanitary arrangements for workers employed directly or indirectly on the works. In case the Contractor fails to make arrangements as aforesaid, the Engineer-in-charge shall be entitled to do so and recover the cost thereof from the contractor.

\



SAFETY CODE

RESPONSIBILITIES OF THE CONTRACTOR IN RESPECT OF SAFETY OF MEN, EQUIPMENT, MATERIAL AND ENVIRONMENT

Before commencing the work, the contractor is required to submit a “SAFETY PLAN” to the authorised BHEL Official. The ‘Safety Plan’ shall indicate, in detail, the measure that would be taken by the contractor to ensure safety of men, equipment, material and environment during execution of the work. The plan shall take care to satisfy all requirements specified hereunder. The contractor shall submit safety plan along with his offer. During negotiations before placing of work order and during execution of the contract, BHEL shall have right to review and suggest modification in the Safety Plan. The contractor shall abide by BHEL’s decision in this respect.

The contractor shall take all necessary safety precautions and arrange for appropriate appliances as per direction of BHEL, or its authorised officials, to prevent loss of human lives, injuries to personnel engaged, and damage to property and environment.

The contractor shall provide to its work force and ensure the use of the following personal protective equipment as found necessary and as directed by the authorised BHEL officials:-

- (i) Safety Helmets conforming to IS – 2925: 1984.
- (ii) Safety Belts conforming to IS – 3521: 1983.
- (iii) Safety Shoes conforming to IS – 1989: 1978.
- (iv) Eye and Face Protection devices conforming to IS – 8520: 1977
and IS – 8940: 1978.
- (V) Hand and body protection devices conforming to:
 - IS – 2573: 1975
 - IS – 6994: 1973
 - IS – 8807: 1978
 - IS – 8519: 1977.

All tools, tackles, lifting appliances, material handling equipment, scaffolds, cradles, safety nets, ladders, equipment etc. used by the contractor shall be of safe design and construction. These shall be tested and certificate of fitness obtained, before putting them to use and from time to time as instructed by authorised BHEL official who shall have the right to ban the use of any item.

All electrical equipment, connections and wiring for constructions, power, its Distribution and use shall conform to the requirement of Indian Electricity Act and Rules. Only electricians licensed by the appropriate statutory authority shall be employed by the contractor to carry out all types of electrical works. All electrical appliances including portable electric tools used by the contractor shall have safe plugging system to source of power and be appropriately earthed.

The Contractor shall not use any hand – lamp energised by electric power with supply voltage of more than 24 Volts. For work in confined spaces, lighting shall be arranged with power source of not more than 24 Volts.

The contractor shall adopt all fire safety measures as laid down in the “Code for Fire Safety at Construction sites” issued by the Safety Department of the Construction management



(HQ) of BHEL and as per the directions of the authorised BHEL official. A copy of the above referred

“Code of Fire Safety at Construction Sites” shall be made available by BHEL to the contractor for reference, on demand by the contractor, during tendering stage itself.

Where it becomes necessary to provide and/or store Petroleum Products, explosives, chemicals and liquid or gaseous fuel or any other substance that may cause fire or explosion, the contractor shall be responsible for carrying out such provisions and/or storage in accordance with the rules and regulations laid down in the relevant government acts, such as Petroleum Act, Petroleum and Carbides of Calcium Manual of the Chief Controller of Explosives, Govt. of India etc., Prior approval of the authorised BHEL official at the site shall also be taken by the contractor in all such matters.

The contractor shall arrange at his cost (wherever not specified), appropriate illumination at all work spots for safe working when natural daylight may not be adequate for clear visibility.

The contractor shall be held responsible for any violation of statutory regulations local, state or central and BHEL instructions, that may endanger safety of men, equipment, material and environment in his scope of work or another contractor's or agency's. Cost of damages if any, to life and property arising out of such violation of statutory regulations and BHEL instructions, shall be borne by the contractor.

In case of a fatal or disabling injury / accident to any person at construction sites due to lapses by the contractor, the victim and/or his/her dependents shall be compensated by the contractor as per statutory requirements. However, if considered necessary, BHEL have the right to impose appropriate financial penalty on the contractor and recover the same from payments due to the contractor for suitably compensating the victim and/or his/her dependents. Before imposing any such penalty, appropriate enquiry shall be held by BHEL giving opportunity to the contractor to present his case.

In case of any damage to property due to lapses by the contractor, BHEL shall have the right to recover cost of such damages from payments due to the contractor after holding an appropriate enquiry.

In case of any delay in the completion of a job due to mishaps attributable to lapses by the contractor, BHEL shall have right to recover cost of such delay from payments due to the contractor, after notifying the contractor suitably and giving him opportunity to present his case.

If the contractor fails to improve the standards of safety in its operation, to the satisfaction of BHEL, after being given a reasonable opportunity to do so and / or / if the contractor fails to take appropriate safety precautions or to provide necessary safety devices and equipment or to carry out instructions regarding safety issued by the authorised BHEL official, BHEL shall have the right to take corrective steps at the risk and cost of the contractor, after giving a notice of not less than seven days, indicating the steps that would be taken by BHEL.

The contractor shall submit report of all accidents, fires and property damage, dangerous occurrence to the authorised BHEL official immediately after such occurrence, but in any case not later than twelve hours of the occurrence. Such reports shall be furnished in the



manner prescribed by the contractor to the authorised BHEL official from time to time as prescribed.

Before commencing the work, the contractor shall appoint/nominate a responsible officer to supervise implementation of all safety measures and liaison with his counterpart of BHEL. If the Safety record of the contractor is to the satisfaction of Safety Department of BHEL, issue of an appropriate certificate to recognise the safety performance of the contractor may be considered by BHEL after completion of the job.



ANNEXURE: 'D'

CLAUSE 38 OF BHEL GENERAL CONDITIONS OF CONTRACT

INSURANCE OF WORKS AGAINST DAMAGE AND LOSS DUE TO FIRE, STRIKE, TEMPEST, FLOODS, EARTHQUAKE, RIOT AND AGAINST DAMAGE BY AIRCRAFT

The contractor shall, within one month after the date of acceptance of the contract, insure the work against loss and damage by fire, tempest, floods, earthquake, riots, strike and against damage by aircraft with an insurance office approved by the accepting officer, from the date of acceptance of work or actual commencement of work whichever is earlier. Such insurance shall be effected in the name of BHEL and shall be for the full value of the contract sum. The contractor shall lodge with BHEL the policies and receipts of the premiums for such insurance and shall maintain such policies in force until the entire completion of the work as certified by the Engineer – In - Charge.

If the contractor fails to comply with the terms of this condition, the accepting officer may insure the work and may deduct the amount of premiums from any money that may become payable to the contractor or may at his discretion refuse payment of any advance/payment to the contractor until the contractor shall have complied with the terms of this condition.

Such insurance whether effected by the Accepting officer or the Contractor shall not be a limit or bar to the liability and obligation of the contractor to complete the entire work in all respects as certified by the Engineer – In – Charge.

In case of such a loss or damage as aforesaid, the money payable under any such insurance shall be received and may be retained by BHEL until the work is finally completed and shall then be credited to the contractor in the final statement of accounts in the event of the contract not having been previously cancelled under these conditions, after taking into account the delay in completion, settlement to his workers for damages, damage to BHEL's Property etc.



ANNEXURE 'E'

CLAUSE 58 OF GENERAL CONDITIONS OF CONTRACT

ARBITRATION:

Except where otherwise provided for in the contract, all questions and disputes relating to the meaning of the specifications, designs, drawings and instructions herein before mentioned and as to the quality of workmanship or materials used on the work or as to any other question, claim, right, matter or thing whatever in any way arising out of or relating to the contract, designs, drawings, specifications, estimates, instructions, orders or these conditions or otherwise concerning the works, or the execution or failure to execute the same whether arising during the progress of the work or after the completion or abandonment thereof shall be referred to the sole arbitration of the Executive Director/General Manager of BHEL and if the Executive Director/General Manager is unable or unwilling to act to the sole arbitration, some other person appointed by the Executive Director/General Manager, willing to act as such Arbitrator. There will be no objection if the arbitrator so appointed is an employee of BHEL-EDN or an employee of any other unit of BHEL and that he had to deal with the matters to which the contract relates and that in the course of his duties as such he had expressed views on all or any of the matters in dispute or difference. The Arbitration to whom the matter is originally referred being transferred or vacating his office or being unable to act for any reason, such Executive Director/General Manager as aforesaid at the time of such transfer, vacation of office or inability to act, shall appoint another person to act as Arbitrator in accordance with the terms of the contract. Such person shall be entitled to proceed with the reference from the stage at which it was left by his predecessor. It is also a term of this contract that no person other than a person appointed by such Executive Director/General Manager or an employee appointed as Arbitrator as aforesaid should act as Arbitrator and the Arbitrator shall give reasons for the award.

Subject as aforesaid the provision of the Arbitration Act, 1940 or any statutory modification or re-enactment thereof and the rules made there under and for the time being in force shall apply to the arbitration proceeding under this clause.

It is a term of the contract that the party invoking arbitration shall specify the dispute or disputes to be referred to arbitration under this clause, together with the amount or amounts claimed in respect of each such dispute.

The arbitrator (s) may from time to time with consent of the parties extend the time, for making and publishing the award.

The work under the contract shall, if reasonably possible, continue during the arbitration proceedings and no payment due or payable to the contractor shall be withheld on account of such proceedings.

The arbitrator shall be deemed to have entered on the reference on the date he issues notice to both the parties fixing the date of the first hearing. The arbitrator shall give a separate speaking award in respect of each dispute or difference referred to him.



The venue of arbitration shall be such place as may be fixed by the arbitrator in his sole discretion. The award of the arbitrator shall be final, conclusive and binding on all parties to this contract.

ANNEXURE 'F'

HEALTH, SAFETY & ENVIRONMENTAL POLICY

The Management is committed to be an environmentally sound company in its activities, products, services and to provide safe and healthy working environment covering its employees, products & services as an integral part of business performance through :

- ★ **Compliance with applicable Legislation and Regulations**
- ★ **Setting objectives and targets to eliminate / control / minimise environmental pollution, risks due to Occupational Health and Safety Hazards**
- ★ **Promotion of activities for conservation of resources by environmental management with focus on oil, electrical energy and chemicals**
- ★ **Enhancement of Environmental, Safety and Occupational Health awareness amongst employees, customers, suppliers, contractors by pro-active communication**
- ★ **Regular evaluation and pro-active measures for prevention & control of environmental pollution/accidents / occupational diseases**
- ★ **Appropriate training of employees and interested parties on Health, Safety & Environmental (HSE) aspects**
- ★ **Formulation and maintenance of HSE Management Programs for continual improvement**
- ★ **Periodic review & audit of HSE Management System to ensure its continuing suitability, adequacy and effectiveness**
- ★ **Communication of HSE Policy to all employees and interested parties**
- ★ **Co-operation with concerned agencies / regulatory bodies engaged in HSE activities.**

EXECUTIVE DIRECTOR
BHEL (EDN) BANGALORE



BHARAT HEAVY ELECTRICALS LIMITED
ELECTRONICS DIVISION
BANGALORE – 560026



GENERAL CONDITIONS OF CONTRACT
FOR
LUMP-SUM, ITEM-RATE AND PERCENTAGE
CONTRACT



REVISED GENERAL CONDITIONS OF CONTRACT w.e. f. 1-4-1975

CONTENTS

Condition
Number Description

CHAPTER –I

1. Definitions

CHAPTER-II

2. Heading to the contractor
3. Contract documents
4. Works to be carried out
5. Provisional items
6. Deviations
7. Time
8. Stores & materials
9. Delay & Extension of time
10. Patent Rights
11. Octroi & other duties
12. Royalties
13. Plant & Equipment
14. Assignment or Transfer of contract
 - a) Sub -contract
15. Compliance to Regulations and Bye –laws

CHAPTER –III

16. Security Deposit
17. Orders under the contract
18. Admission to site
19. Contractor's Supervision
20. Labour
21. Water
22. Temporary Workshops, stores etc.,
23. Stores & materials-on-site etc
24. Tools & plant on site
25. Statement of Hire charges
26. Precautions against Risks
27. Notices & Fees
28. Setting out of the works and protecting & maintaining signal marks
29. Site drainage
30. Excavations, relics, etc.,



31. Foundations
32. Covering in work
33. Approval of works by stages
34. Execution of works
35. Day work
36. Inspection of the work
37. Responsibility for building

38. Insurance of works against damage and loss, due to fire, tempest, floods etc.
39. Damage or loss to private property and injury to workman.
40. Completion
41. Compensation for delay.
42. Laws governing the contract.
43. Cancellation of contract for corrupt act.
44. Cancellation of contract for insolvency, assignment or sub-letting of contract
45. Cancellation of contract for default.
46. Termination of contract for death.
47. Special powers or determination.
48. Fair wage.

CHAPTER-IV

VALUATION & PAYMENT

49. Records and measurements.
50. Valuation of deviations.
51. Reimbursement / refund on variation in price.
52. Advances on account.
53. Final bill.
54. Payment of bills.
55. Recovery from contractor.
56. Post-technical audit of work and bills.
57. Refund of security deposit.

Annexure-‘A’

BHEL contractor’s Labour Regulation and BHEL safety code (See Condition 20)



1. DEFINITIONS

In these general conditions of contract, the following terms shall have the meaning hereby assigned to them except where the context otherwise requires:

- a) The “CONTRACT” means the documents forming the tender and acceptance thereof , together with all the document referred to therein including general and Special Conditions of Contract, Schedules ‘A’, ‘B’, ‘C’, ‘D’, ‘E’ and/or General Summary attached to the form of tender, the Karnataka P.W.D. Schedule of Rates as amended up to 1979-80 the specifications and the Drawings. All these documents as applicable taken together shall be deemed to form one contract and shall be complementary to one another.
- b) The “TENDER DOCUMENTS” means the form of tender, the applicable schedules ‘A’, ‘B’, ‘C’, ‘D’, ‘E’ and / or General summary, General and Special conditions of contract and the specifications and / or drawings as given to contractors on payment for the purpose of preparing their tenders
- c) The ‘WORK’ means the work described in the tender documents, in individual work orders and/ or accompanying drawings and specifications as may be issued from time to time to the Contractor by the Engineer or deputy manager (projects) or the Engineer- in- charge within the powers conferred upon them, including all modified or additional works and obligations to be carried out either at the site or at any Factory workshop or other place as required for the performance of the contract.
- d) The “SITE” means the land and /or other places on, in, into or through which the work is to be executed under the contract or any adjacent land , path or street which may be allotted to or used for the purpose of carrying out the contract.
- e) The “CONTRACTOR” means the individual, firm or company, whether incorporated or not, undertaking the work and shall include the legal personal representatives of such individuals or the persons composing the firm or company, or the successors of the firm or Company and the permitted assigns of such individual or firm or company.
- f) The abbreviations DGM/P, Sr. M/P, S.E/C means Dy. General Manager /Projects, Senior Manager / Projects, and Senior Engineer respectively, who direct the contract and the letters E/C means Engineer in-charge of the particular work pertaining to the contract.
- g) The “Engineer – in – charge” means the Engineer who is overall in charge of the work or deputed to supervise the work, or part of the work.
- h) “APPROVED” and “DIRECTED” means the approval or direction of the DGM/P. Sr. M/P, or S.E/C, Engineer-in-charge. or person deputed by them for the particular purpose.
- i) “BHARAT HEAVY ELECTRICALS LIMITED” hereinafter referred to as BHEL Shall mean the board of directors, Resident Director, General Manager/ Project Administrator or other



Administrative Officers, of the said company including the project officer, Sr, Manager / Projects, Senior Engineer or Engineer authorised to invite tenders and enter into the contracts for works on behalf of “Bharat Heavy Electrical Limited”, unit : Electronics Division, Mysore Road, Bangalore – 26.

- j) In the case of lumpsum contracts, CONTRACTOR’S PERCENTAGE” means the percentage offered by the contractor as addition to or deduction from the cost of buildings, or other works listed in schedule, ‘A’ to provide a lump sum quotation for performance of the contract inclusive of all extra costs, profit, establishment charges, carriage, insurance etc., complete.
1. In the case of percentage rate contracts, “ Contractor’s percentage” shall, if the context so permits, mean the uniform percentage tendered by the contractor and accepted by the Accepting Officer, and the expression “ CONTRACT RATE” shall like wise mean the rates in the K.P.W.D. schedule of rate as amended up to 1979-80 as adjusted by the said Contractor’s percentage, if any.
- k) The “ CONTRACTOR SUM” means the sum accepted, or the sum calculated in accordance with the prices accepted in the tender and / or the contract rates as payable to the Contractor for the entire execution and full completion of the work.
- l) the “FINAL SUM” means the actual amount payable under the contract by BHEL, to the Contractor for the entire execution and full completion of the work.
- m) The “ DATE OF COMPLETION” is the date or dates for completion of the whole or any part of the work as set out in or ascertained in accordance with the individual work orders or the tender documents ,or any subsequent agreed amendments thereto.
- n) A “WEEK” means seven days without regard to the number of hours worked or not worked in any day in that week.
- o) A”DAY” means a day of 24 (Twenty four) hours irrespective of number of hours worked or not in that day.
- p) A “WORKING DAY” means any day other than that prescribed by the Negotiable instruments ACT as being a holiday , consists of the number of hours of labour as commonly recognised by good employers in the trade in the District where the work is carried out or as laid down in the BHEL Regulations.
- q) “DEVIATION ORDER” means an order given by the Engineer-in-charge to effect an alteration ,addition or deduction, which dose not radically affect the scope of nature of the contract.
- r) “EMERGNCY WORK” means any urgent measures which , in the opinion of the Engineer-in-charge , become necessary during the progress of the work to obviate any risk of accident or failure or which become necessary for security.
- s) “PROVISIONAL SUM” or “PROVISIONAL LUMPSUM” means a lump-sum included by the BHEL in the tender documents and represents the estimated value of work for which details are not available at the time of inviting the tender.
- t) “PROVISIONAL ITEMS” means items for which approximate quantities have been included in the tender documents.
- u) “DAY WORK” means on item of work requiring the employment of labour with or without materials as the case may be , which, in the opinion of the Engineer -in-charge, is not capable of being evaluated by the accepted methods of measurement or assessment and is paid for on the basis of the actual labour and materials utilised on the particular item of work referred to.



Chapter-II

SCOPE OF CONTRACT

2. HEADING TO THE CONTRACT

The heading to these conditions shall not affect the interpretation thereof

3. CONTRACT DOCUMENTS:

The accepting officers shall furnish to the Contractor on demand "FREE OF COST" three copies of signed Drawings and one copy of the signed agreement comprising of preamble to Agreement, General and Special Specifications, Schedules 'A' 'B' 'C' 'D' and 'E' etc. (but excluding General Conditions of Contract and Drawings) and three copies of all further drawings issued during the progress of work.

However, for any additional copies of the agreement or drawings required by the Contractor, the same will be supplied on payment of the Specified Cost.

The contractor shall keep one copy of all the drawings and of the specifications on the site and the Engineer-in-charge or his representative shall at all reasonable times have access to them.

4. WORK TO BE CARRIED OUT :

The Contract shall, except as provided under Schedules 'B' and 'C' include all labour, materials, tools, plant, equipment and transport which may be required in preparation for, and in the entire execution and full completion of the work. Schedule 'A' shall be deemed to have been prepared in accordance with good practice and recognised principles and unless otherwise stated, the descriptions given therein shall be held to include waste on materials, carriage and cartage, lead, return of empties, hoisting, setting, fitting in position and all other labour necessary in and for the entire execution and full completion aforesaid. Any error in description or quantity in Schedule 'A' or any omission therefrom shall not vitiate the Contract or release the Contractor from the execution of the whole or any part of the work comprised therein according to the drawings and specifications, or from any of his obligations under the contract. The insertion of the name of any firm of suppliers in the Tender Documents is for the purpose of obtaining a particular class or quality of materials or workmanship but the articles or materials specified may be obtained from any other firm subject to the prior written approval of the Engineer-in-charge.

In the case of a discrepancy between Schedule 'A' the Specifications and/or the Drawings, the accepting officer shall be the sole deciding authority as to which shall prevail and his decision shall be final and conclusive. If neither drawings nor specifications contain any mention of minor details of construction, which in the opinion of the Accepting Officer whose decision shall be final and conclusive, are reasonable and obvious and fairly intended for the satisfactory completion of the work, such details shall be provided by the Contractor without any extra cost as if they were specially mentioned and shall be deemed to be included in the contract.



The Contractor will be deemed to have satisfied himself as to the nature of the site , local facilities of access and all matters affecting the execution and completion of the work. **No extra** charges consequent on any misunderstanding in these respects or otherwise will be allowed.

5. PROVISIONAL ITEMS:

The full amount of provisional lump-sum and the value annexed to each provisional item inserted in the Tender documents shall be deducted from the contract sum and the value of work ordered and executed there under shall be ascertained by measurement or valuation as for deviations.

No work under these items is to be begun without instructions in writing from the Engineer- in – charge.

The extent of quantities or items described as “ provisional “ shall not be held to guarantee or limit the amount and description of the work to be executed by the Contractor either in respect of the item concerned or the work as a whole.

No addition or deduction shall be made by the Contractor to the amount of the provisional lump-sums as included in the tender documents.

6. DIVIATIONS:

The contractor shall not make any alteration in addition to or omission from the work as described in the tender documents except in pursuance of the written instruction of the Engineer –in charge. No such deviation from the work described in the tender documents shall be valid unless the same has been specifically confirmed and accepted by the Accepting Officer in writing and incorporated in the contract.

The accepting Officer may deviate, either by way of addition or deduction, from the work so described, provided that the contractor sum is not thereby varied on the whole by more than the percentage set out in the tender documents. The value of all additions and deductions will be added to, or deducted from the contract sum. Whenever the Accepting Officer intends to exercise such a right, his intention shall specify the deviation which are to be made, the lump sum assessment or the proposed basis of payment, the extra time allowed, if, any and the date for completion of the entire contract.

Any objection by the Contractor to any matter concerning the order shall be notified by him in writing to the Engineer-in-charge within SEVEN DAYS from the date of such order, but under no circumstances shall the work be stopped (unless so ordered by the Engineer-in-charge) owing to differences or controversy that may arise from such an objection. In the absence of such a notification of objection, by the contractor, he will be deemed to have accepted the order and the conditions stated therein. In the event of the contractor, failing to agree with the Engineer-in-charge regarding the terms of the proposed deviation, the objections shall be referred to the DGM/P/Sr.M/P, whose decision shall be final, conclusive and binding on the Contractor.

7. TIME:

Time is the essence of the contract and is specified in the tender document or in each individual work order.



As soon as possible after the contract is let or any substantial work order is placed and before work under it is begun, the Senior Engineer or Engineer-in-charge and the contractor shall (if so required by the Sr. E/C/ Engineer-in-charge agree to a time and Progress chart. The chart shall be prepared in direct relation to the time stated in the tender documents or the Work Order for the completion of the individual items thereof, and/or the contract or Orders as a whole. It shall indicate the forecast of the dates for the commencement and completion of the various trade processes or sequences of the work, and shall be amended as may be required by agreement between the Sr. E/C or Engineer-in-charge, and the contractor within the limitation of the time imposed in the tender documents or ORDER.

In the absence of any specific Time and Progress Chart to be agreed to between the Contractor and the Sr. E/C. or Engineer –in-charge, the contractor shall ensure and maintain uninterrupted progress of the work such that the entire work shall be completed within the time imposed in the tender document or order and that the proportion of work completed up to any time in relation to the entire work to be done under the Contract or Order shall not be less than the proportion that the time elapsed bears to total time of completion provided in the Tender Documents or Order.

The Contractor shall suspend the execution of the work, or any part or parts there of whenever called upon in writing by the Engineer –in –charge to do so, and shall not resume work thereon until so directed in writing by the Engineer –in –charge. The Contractor will be allowed an extension of time for completion not less than the period of suspension but no other claim in this respect for compensation or otherwise how so ever will be admitted. This may also be extended to allow for alteration of work made by the deviation order.

8. STORES AND MATERIALS:

The contractor shall, at his own expense , supply all stores and materials required for the contract, other than those listed in Schedule ‘B’ which may be provided by Bharat Heavy Electricals Limited at the rates detailed therein subject to their availability at the place of issue indicated therein. All stores and materials to be supplied by the Contractor shall be of the best kind as described in the Specifications and the Contractor shall, if required by the Engineer-in-charge furnish him with proof to his satisfaction that the stores and materials so comply with the specifications.

The contractor shall, at his expense and without delay, supply samples of stores and materials proposed to be used in the execution of the work for the approval of the Engineer-in-charge, who may reject all stores and materials not corresponding either in quality or character to the approved samples.

In the case of stores provided under Schedule ‘B’ the Contractor shall bear the cost of loading, transporting to site, unloading, storing under cover as required, assembling & jointing the several parts together as necessary and incorporating & fixing these stores & materials in the work, including all preparatory work of whatever description that may be required, and closing, preparing, loading and returning empty cases or containers to the place of issue without any extra charges.

9. DELAY AND EXTENSION OF TIME:

If, in the opinion of Engineer-in-charge the work is delayed:



- i) by reason of abnormally bad weather, or
- ii) by reason of serious loss or damage by fire, or
- iii) by reason of civil commotion, local combination of workmen, strike or lockout, affecting any of the trades employed on the work, or
- iv) by delay on the part of the agency or tradesman engaged by BHEL in executing work not forming part of this contract, or
- v) by reason of any other cause which in the absolute discretion of the Sr. M/P. Sr. E/C. or E/C is (when he is the Accepting Officer of the Contract) beyond the contractors control, then in any such case, the Accepting Officer, on the recommendation of the Sr. E/C., E/C (or higher authority) may make fair and reasonable extension in the completion dates of the individual items of work or the contract as a whole. Such extension which will be communicated to the contractor by the Sr. E/C./E/C. in writing shall be final and binding on the contractor. No other claim in this respect for compensation or otherwise howsoever is admissible. Upon the happening of any such event causing delay, the contractor shall immediately give notice thereof in writing to the Engineer-in-charge but shall nevertheless use constantly his best endeavour to prevent or make good the delay and shall do all that may reasonably be required to the satisfaction of the Engineer-in-charge to proceed with the work.

10. PATENT RIGHTS:

The contractor shall fully indemnify BHEL, or the agent, servant, or employee of BHEL, against any action, claim or proceeding relating to infringement or the use of any patent or design or any alleged patent or design rights, and shall pay any royalties which may be payable in respect of any article/ or part thereof included in the contract.

In the event of any claims being made or action brought against BHEL, or any agent, or servant or employee of BHEL., in respect of any of the matters aforesaid, the contractor shall immediately be notified thereof for taking necessary action provided that payment of indemnity shall not apply when such infringement has taken place in complying with the specific directions issued by the BHEL....but the contractor shall pay any royalties payable in respect of any such use.

11. OCTROI AND OTHER DUTIES:

All charges on account of octroi, Terminal or Sales Tax and / or other duties on materials obtained for the work (excluding materials provided by BHEL, on payment) shall be borne by the contractor.

12. ROYALTIES:

Royalties fixed from time to time as per prevalent local rules will be recovered for materials, which the contractor may be allowed to remove from quarries situated on land which is in charge of the BHEL ., authorities.



13. PLANT AND EQUIPMENT:

The contractor, shall at his own expenses, supply all tools, plant and equipment (herein-after referred to as T & P) required for the execution of the contract, as specified in the tender documents.

14. ASSIGNMENT OR TRANSFER OF CONTRACT:

The contractor shall not, without the prior written approval of the Accepting Officer, assign or transfer the contract or any part thereof, or any share, or interest therein to any other person. No sum of money which may become payable under the contract shall be payable to any person other than the contractor unless the prior written approval of the Accepting Officer to the assignment or transfer of such money is given.

a) SUB-CONTRACT:

The contractor shall not sub-let any portion of the contract without the prior written approval of the Accepting Officer

15. COMPLIANCE TO REGULATION AND BYE-LAWS :

The contractor shall conform to the provisions of any statute relating to the work and regulations and bye-law of any local authority and of any water and lighting Companies or Undertakings with those system the works is proposed to be connected. He shall before making any variation from the drawings or the specification that may be necessitated for such connection give the Engineer-in-charge notice, specifying the variation proposed to be made and the reason therefore and shall not vary out any such variation until he has received instructions from the Engineer-in-charge in respect thereof. The contractor shall be bound to give all notices required by statute regulations or bye-laws as aforesaid and to pay all fees and taxes payable to any authority in respect thereof.

CHAPTER-III

PERFORMANCE OF THE CONTRACT

~~16. SECURITY DEPOSIT:~~

- ~~i) The amount of security money to be deposited for proper fulfillment of the contract will be as follows:~~
- | | | |
|---|------------------|--|
| a) For contract valued upto Rs. 1.00 lakh. | | 10% of the contract value. |
| b) For contract valued above Rs. 1.00 lakh but not exceeding Rs. 2.00 lakhs. | | 10% on the 1st Rs. 1.00 lakh Plus 7 ½ % on the balance of the contract Value. |
| c) For contracts valued above Rs. 2.00 lakhs. | | 10% on the 1st Rs. 1.00 lakh Plus 7 ½ on the next Rs.1.00 lakh Plus 5% on the balance of the contract value. |
- ~~ii) The contractor whose tender may be accepted shall within seven days of receipt by him of the notification of acceptance of his tender, deposit with the BHEL, Unit: Bangalore the prescribed sum as per Clause 16 (i) above towards security deposit.~~

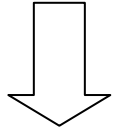

Refer clause no. 45.1 of Instruction to tenderer.

The Earnest Money Deposited at the time of tender will be treated as part of the Security Deposit and the balance amount to make up the full Security Deposit as referred to in Clause 16(i) above may be furnished in Cash or in any of the following forms duly pledged to the BHEL Limited.

- Call Deposit Receipt, Pay Order or Demand Draft.
- Post Office cash certificates, National Savings Certificates, Treasury Saving Deposit Certificates, National Plan Saving Certificates, 12 year National Defence Certificates and 10 year Deposit Certificates.
- Fixed Deposit Receipt issued by State Bank of India/ Nationalised Bank/ Scheduled Bank.
- Bank Guarantee from Nationalised /Scheduled Bank valid for a period inclusive of the maintenance period also after the date of completion of the work, wherever warranted.
- Insurance Guarantee issued by L.I.C. or any of the four General Insurance Corporations valid for a period inclusive of the maintenance period also after the date of completion of work, where warranted.

Alternatively the requisite amount to make up the full Security Deposit may also be deducted, from each Running bill in respect of the particular contract concerned at 10% (ten percent) of the value of the work done by the Contractor as billed till such deductions along with the Earnest money already deposited by him shall make up the full Security Deposit as per para 16 (i) above.

No interest shall be allowed on Security Deposits.



BHEL, shall not be responsible for any loss of Securities due to liquidation or any other reason whatsoever or any depreciation in the value of the Securities while in their charge or for any loss of interest thereon.

- iii) All compensation or other sums of money payable by the Contractor to BHEL under the terms of this contract or under any other contract with BHEL, may be deducted from the Security Deposit or realised by the Sale of Securities or from the Interest arising therefrom or from any sums which may be due or may become due to the Contractor payable by BHEL, on any account whatsoever against this contract or any other contract with BHEL, and in the event of his Security Deposit being reduced by reason of such deduction or sale as aforesaid, the contractor shall, within seven days thereafter, make good in cash or in securities endorsed as aforesaid, any sums by which the Security Deposit has been so reduced.
- iv) 50% of the Security Deposit may be refunded on completion of the work after payment of the final bill and the balance 50% of the Security Deposit is refunded only after the expiry of the maintenance period of six (6) months from date of completion of work or as stipulated in the contract concerned.

17. ORDERS UNDER THE CONTRACT:

All orders, notices etc. to be given under the contract shall be in writing, type script of printed and if sent by registered post to the address given in the tender of the contractor, shall be deemed to have been served on the date when in the ordinary course they would have been delivered to him.

The contractor shall carry out without delay all orders given to him.

18. ADMISSION TO SITE:

The contractor shall not enter on (other than for inspection purposes) or take possession of the site unless permitted to do so by the Engineer-in-charge. The portions of the site to be occupied by the Contractor will be clearly defined and marked on the site plan, and the contractor will on no account be allowed to extend his operations beyond these areas. The Contractor shall provide, if necessary, or required at the site, temporary access thereto and shall alter, modify and maintain the same as required from time to time. He shall take out and clear away the access route when no longer required restoring the area to its original conditions.

The Engineer-in-charge shall have power to execute other works (whether or not connected with the work in the contract agreement) in the site contemporaneously with the execution of the original work and contractor shall give reasonable facilities for this purpose.

BHEL, reserves the right of taking over, at any time, and portion of the site which they may require and the contractor shall at his own expense clear such portion forthwith. No photographs of the site or of the work or any part thereof shall be taken, published or otherwise circulated, without the prior approval of the Engineer-in-charge.

No such approval shall however exempt the contractor from complying with any statutory provisions in regard to the taking and publication of such photographs.

BHEL officials connected with the contract shall have the right of entry to the site at all times.



Engineer-in-charge shall have the power to exclude from the site any person whose admission thereto may, in his opinion, be undesirable for any reason whatsoever.

19. CONTRACTORS SUPERVISION:

The Contractor shall either himself supervise the execution of the Contract or shall appoint a competent Agent approved by the Engineer-in-charge to act in his stead.

The contractor shall employ an Engineer/Agent having atleast a 'Degree of Bachelor of Engineering' from a recognised University/on any work with a Contract value exceeding rupees two lakhs and having atleast a 'Diploma in Engineering' from a recognised college on work with a contract value exceeding Rs. 50,000/- but not exceeding rupees two lakhs.

The employment of an Engineer/Agent as aforesaid, shall not be necessary if the contractor is in possession of a recognised technical qualification and is in opinion of the Engineer-in-charge capable of receiving instructions of the Engineer-in-charge and of executing the work to the satisfaction of the Engineer-in-charge.

If the contractor fails to appoint a suitable Engineer/Agent as aforesaid, the Engineer-in-charge shall have full powers to suspend the execution of work and stop payment of any advances that may have become due until such date as a suitable Engineer/Agent is appointed and the contractor shall be held responsible for the delay caused to the work and no extension of time on this account shall be given to him as stipulated in condition (9) above.

Orders given to the contractors Agent/Engineer shall be considered to have the same force as if they had been given to the contractor himself.

The contractor or his agent shall be in attendance at the site during all working hours and shall superintend the execution of work with such additional assistance in each trade as the Engineer-in-charge may consider necessary.

The contractor or his accredited agent shall attend, when required and without making any claim for doing so, either the Office of the Engineer-in-charge or the work-site to receive instructions.

The Engineer-in-charge shall have full powers, and without assigning any reason, to require the contractor immediately to cease to employ in connection with this contract any agent, servant or employee whose continued employment is, in his opinion, undesirable.

The contractor shall not be allowed any compensation on this account.

20. LABOUR:

The contractor shall employ labour in sufficient numbers either directly or through sub-contractors to maintain the required date of progress and of quality to ensure workmanship of the degree specified in the contract and to the satisfaction of the Engineer-in-charge. The contractor shall not employ in connection with the works any person who has not completed his fifteen years of age.

The contractor shall furnish to the Engineer-in-charge at the intervals specified by him, a distribution return of the number and description by trades of the work people employed on the works. The contractor shall also submit on the 4th and 19th of every month to the Engineer-in-



charge a true statement showing in respect of the second half of the preceding month and the first half of the current month (i) the accident that occurred during the said fortnight showing the circumstances under which they happened and the extent of damage and injury caused by them and (ii) the number of female workers who have been allowed maternity benefit as provided in the maternity benefit Act, 1961 or Rules made there under and the amount paid to them.

The contractor shall pay to labour employed by him either directly or through sub-contractors wages not less than fair wages as defined in the contractors labour regulations.

The contractor shall in respect of labour employed by him either directly or through sub-contractors comply with or cause to be complied with contractors Labour Regulations in regard to all matters provided therein.

The contractor shall comply with the provisions of the payment of Wages Act, 1936, Minimum Wages Act, 1948, Employers Liability Act 1938. Workman's Compensation Act, 1923, industrial Disputes Act, 1947, Maternity Benefit Act, 1961 and Mines Act 1952 or any modifications thereof or any other law relating there to and rules and there under from time to time.

The contractor shall be liable to pay his contribution and the employees contribution to the State Insurance Scheme in respect of all labour employed by him for the execution of the contract, in accordance with the provision "The Employees" State Insurance Act, 1948" as amended from time to time. In case the contractor fails to submit full details of his account of labour employed and the contribution payable, the Engineer-in-charge shall recover from the running bills of contractor an amount of contribution as assessed by him. The amount so recovered shall be adjusted against the actual contribution payable for employees' State Insurance.

The Engineer-in-charge shall on a report having been made by an inspecting Officer as defined in the contractors labour regulations have the power to deduct from the moneys due to the Contractor any sum required or estimated to be required for making good the loss suffered by a worker or workers by reason of non-fulfillment of the conditions of the contract for the benefit of workers, non-payment of wages or of deductions made from his or their wages which are not justified by the terms of the contract or non-observance of the said contractors labour Regulations.

The contractor shall indemnify the BHEL against any payments to be made under for observances of the Regulations aforesaid without prejudice to his right to claim indemnify from his sub-contractors.

In the event of the Contractor committing a default or breach of any of the provisions of the aforesaid Contractors Labour Regulations, as amended from time to time or furnishing any information or submitting or filling any form/Register/Slip under the provisions of these regulations which is materially incorrect, then on the report of the Inspecting Officers as defined in the Contractors Labour Regulation, the contractor shall without prejudice to any other liability pay to the BHEL a sum not exceeding to Rs.50/- as liquidated damages for every default breach or furnishing, making, submitting, filling materially incorrect statement as may be fixed by the Engineer-in-charge and in the event of the contractors default continuing in this respect, the liquidated damages may be enhanced to Rs. 50/- per day for each day of default subject to a maximum percent of the estimated cost of works put to tender.



The Engineer-in-charge, shall deduct such amount from bills or security deposit of the contractor and credit the same to the Welfare fund constituted under Regulations. The decision of the Engineer-in-charge in this respect shall be final and binding.

MODEL RULES FOR LABOUR WELFARE:

The contractor shall at his own expense comply with or cause to be complied with model Rules for Labour Welfare as appended to these conditions as rules framed by Government from time to time for the protection of health and for making sanitary arrangements for workers employed directly or indirectly on the works. In case the contractor fails to make arrangements as aforesaid, the Engineer-in-charge shall be entitled to do so and recover the cost thereof from the Contractor.

SAFETY CODE:

The contractor shall at his own expense arrange for the safety provisions as appended to these conditions or as required by the Engineer-in-charge, in respect of all labour directly or indirectly employed for performance of the works and shall provide all facilities in connection therewith. In case the contractor fails to make arrangements and provide necessary facilities as aforesaid, the Engineer-in-charge shall be entitled to do so and recover the cost thereof from the contractor.

Failure to comply with model Rules for Labour Welfare, Safety Code, or of the provisions relating to report on accidents and to grant of maternity benefits to female workers shall make the Contractor liable to pay to the BHEL as liquidated damages an amount not exceeding Rs 50/- for each default or materially incorrect statement. The decision of the Engineer-in-charge in such matters based on reports from the Inspecting Officers as defined in the contractors Labour Regulation as appended to these conditions shall be final and binding and deductions for recovery of such liquidated damages may be made from any amount payable to the Contractor.

21. WATER :

The contractor shall allow in his tender and provide at his cost all water required for the work or his employees on the work, together with all pipes and fittings or other means that may be necessary or required to ensure a proper and ample supply of water for all purposes connected with the work.

In the event of a provision existing in the Tender documents for supply of water on payment by Bharat Heavy Electricals Limited, water will be supplied from the BHEL supply System, or other sources at any points fixed by the Engineer-in-charge on the site of work. The contractor shall make necessary arrangement for lifting, pumping, carrying or conveying the water as required at his own cost. The levy of water charges to be borne by the Contractor in such case shall be specifically mentioned in the Tender documents.

22. TEMPORARY WORKSHOPS, STORES ETC :

The Contractor shall, during the progress of the work provide, erect and maintain at his own expenses all necessary temporary workshops, stores, offices etc., required for the proper and efficient execution of the work. The planning, sitting and erection of these buildigs. Shall have the approval of the Engineer-in-charge and the Contractor shall at all times keep them tidy and in a clean and sanitary condition to the entire satisfaction of the Engineer-in-charge.



On completion of the work all such temporary buildings shall be cleared away and the site restored and left in a clean and tidy condition to the entire satisfaction of the Engineer-in-charge.

23. STORES AND MATERIALS ON SITE :

All stores and materials required for the work are to be deposited by the Contractor only in places to be indicated by the Engineer-in-charge.

Where in accordance with the contract stipulations certain Stores and Materials (for incorporation in the work) are to be issued to the Contractor by the BHEL as detailed under Schedule 'E' such times will be so issued only to the extent required for the actual completion of the work as stipulated in the Contract. The decision of the Engineer-in-charge regarding the quantities to be issued as above shall be final and binding on the Contractor. For any excess quantities consumed on the work their cost will be recovered from the Contractor at punitive rates which will be 100% (hundred percent) more than the issue rates of the BHEL.

In regard to the materials and stores which may be issued to the contractor by BHEL the Contractor shall give the Engineer-in-charge reasonable notice in writing of his requirements of such stores and materials and on the approval of his demand being notified to him, he shall make immediate arrangements for drawing the same. Such stores and materials shall be transported by Contractor at his own expenses direct from the place of issue to the site of the work, unless prior written approval is obtained from the Engineer-in-charge to take them to a store or workshop elsewhere.

The Contractor shall have to build a weather-proof shed for the storage of cement required for 15 days consumption of the work.

BHEL officers connected with the Contract shall have the power at any time to inspect and examine any stores or materials indented to be used in or on the work, whether on the site or at any factory or workshop or other place where such stores or materials are being fabricated or manufactured or at any place where the same are lying and the contractor shall give necessary facilities for such inspection and examination.

The Engineer-in-charge shall be entitled to have tests made of any stores or materials supplied by the Contractor who shall provide at his own expense all facilities which the Engineer-in-charge may require for this purpose. If at the discretion of the Engineer-in-charge an independent expert is employed to make any such tests his charges shall be borne by the contractor only if the test discloses that the said stores or materials are not in accordance with the provisions of the contract.

Should the Engineer-in-charge consider at any time during the construction or re-construction, on prior to the expiry of the 'MAINTENANCE PERIOD', that the stores or materials provided by the Contractor are unsound or of a quality inferior to that contracted for, or otherwise not in accordance with the Contract, (in respect whereof the decision of the Engineer-in-charge shall be final and conclusive) the contractor shall on demand, in writing from the Engineer-in-charge specifying the stores or materials complained of, notwithstanding that the same may have been inadvertently passed, certified and paid for, forthwith remove the stores or materials so specified and provide other proper and suitable store or materials at his own expense; to the entire satisfaction of the Engineer-in-charge and in the event of his failing to do so within a period to be specified by the Engineer-in-charge in his demand aforesaid, the Engineer-in-charge may



replace within others the stores or materials complained of at the risk and expense in all respects of the Contractor. The liability of the contractor under this condition shall not extend beyond the maintenance period aforesaid except as regards stores or materials, which the Engineer-in-charge shall have previously given notice of to the contractor to replace. (Maintenance period for any work under this organisation will be six months from the date of actual completion of the particular work and handing over to BHEL).

All stores and materials brought to the site shall become and remain the property of BHEL and shall not be removed from the site without the prior written approval of the Engineer-in-charge. However, when the work is finally completed the Contractor shall at his own expense forthwith remove from the site all surplus stores and materials originally supplied by him and upon such removal, the same shall re-vest in and become the property of contractor. All BHEL stores and materials issued to Contractor for incorporation or fixing in the work and which, making due allowance for reasonable wear and tear/or waste, have not on completion of the work been so incorporated or fixed, shall be returned by the Contractor at his own expense to the place of issue.

Credit for surplus and/or materials returned by the contractor to BHEL will be given to him at a price based on the prevailing market rate but not exceeding that at which the said stores and materials were originally issued to him but due consideration shall be given to the allowance claimed by BHEL in respect of any depreciation or damages suffered by the stores and/or materials whilst in the custody of the contractor regarding which the decision of Engineer-in-charge shall be final and conclusive.

If , in the opinion of the Engineer-in-charge (which shall be final and conclusive) any stores supplied by BHEL have either during currency of the work or after completion of the work whilst under the custody of the contractor, become damaged to such an extent that they cannot be usefully utilised, either in the same work or in other works, the Engineer-in-charge shall not accept the stores and in the extent of his rejecting , the Contractor shall be charged for the said stores at a rate fixed by the Accepting Officer. The Contractor shall not be entitled to any claim what-so-ever on this account.

23(a).DEFECTS LIABILTY PERIOD :

The contractor shall be responsible to make good and remedy at his own expenses within such period as may be stipulated by the Engineer-in-charge, any defect which may develop or may be noticed before the expiry of the maintenance period of six months hereto from the certified date of completion and intimation of which has been sent to the contractor within seven days of the expiry of the said period by a letter sent by hand delivery or by registered post.

24. TOOLS AND PLANT ON SITE :

All tools, plant and equipment brought to the site shall become the property of BHEL and shall not be removed from the site without the prior written approval of the Engineer-in-charge. When the work is finally completed or the Contractor is determined for reasons other than the defaults of the contract, he shall forthwith remove from the site all tools, plants, equipment etc., (other than those as may have been provided by BHEL) and upon such removal, the same shall re-vest in, and become the property of the contractor.



25. STATEMENT OF HIRE CHARGES :

A monthly detailed statement of the hire charges incurred in respect of BHEL tools, plants, equipment etc., shall be given to the contractor by the Engineer-in-charge.

26. PRECAUTIONS AGAINST RISK :

The contractor shall be responsible for providing at his own expense, for all precautions to prevent loss or damage from any and all risks and to minimise the amount of any such loss or damage and for the necessary steps to be taken for the said purpose until the works have been handed over complete in all respects to the Engineer-in-charge.

The contractor shall provide all watchmen necessary, for the protection of the site, the work, the materials, tools, plant, equipment and anything else lying on the site during the progress of the work. He shall solely be responsible for and shall take all reasonable and proper steps for protecting, securing, lighting and watching all places on or about the work and the site which may be dangerous to any person whom so ever.

27. NOTICES AND FEES :

The contractor shall give all notices required by any statutory provision or by the regulations and/ or bye-laws of any local authority and / or of any Public Service, Company or Authority affected by the work or with whose system the same are or will be connected. The contractor shall pay and indemnify BHEL against any fees and charges, demandable by law under such Acts, Regulations and/ or bye-laws in respect of the work and shall make and supply all drawings and plans required in connection with any such notice.

28. SETTING OUT OF THE WORKS AND PROTECTIVE AND MAINTAINING SIGNALS AND WORKS :

The engineer-in-charge shall supply dimensioned drawing, levels and other information necessary to enable the contractor to set out the work. The contractor shall at his own expense set out accurately according to the drawing and figured dimension thereon, all the work comprised in the contract and any extras or additions thereto and shall be solely responsible for their being so set out and executed.

All bench marks, pegs, signals, on the surface, alignment stones, milestones and all similar marks whether put in by BHEL Authority for the purpose of checking the contractors work or in the nature of permanent survey marks will during the tenure of the contract, be under the care of the contractor who shall , at his own expense , take all proper and reasonable precautions and care to preserve and maintain them in their true position. In the event of these marks being disturbed or obliterated by accident or due to any other cause whatsoever, the same may, if deemed necessary to be replaced by the Sr.E/C/. E/C at the contractors expense and the cost thereof deducted from any money then or thereafter becoming due to the contractor.

Where requested by the contractor, the level marks centre line and chainage pegs corresponding to those shown on the drawing will be pointed out to the contractor on the ground but all bench marks or chainage pegs additional to those shown on the drawing will be set out by BHEL authorities.



29. SITE DRAINAGE :

All water that may accumulate on the site during the process of the work, or in trenches and excavations shall be removed to the entire satisfaction of the Engineer-in-charge and at Contractors expense.

30. EXCAVATIONS, RELICS, ETC :

Material of any kind obtained from excavation on the site shall remain the property of BHEL and shall be disposed off as the Engineer-in-charge directs.

All gold, silver, oil and other minerals of any description and all precious stones, coins, treasured, relics, antiquities and other similar items which may be found in or upon the site shall be the property of Bharat Heavy Electricals Limited and Contractor shall duly preserve the same to the satisfaction of the BHEL and shall from time to time deliver the same to such person or persons as the Bharat Heavy Electricals Limited, may appoint to receive the same.

31. FOUNDATIONS :

The contractor shall not lay any foundations until the excavations for the same have been examined and approved in writing by the Engineer-in-charge.

32. COVERING-IN WORK :

The contractor shall give reasonable notice in writing to the Engineer-in-charge whenever any work is to be permanently covered up or concealed, whether by earth or other means so that it can finally be inspected or measured, if necessary. In default of so doing, the contractor shall, if required by the Engineer-in-charge uncover such work at his own expense.

33. APPROVAL OF WORKS BY STAGES :

All work embracing more than one process shall be subject to examination and approval at each stage thereof and the contractor shall give due notice in writing to the Engineer-in-charge when each stage is ready. In default of such notice being received, the Engineer-in-charge shall be entitled to approve the quality and extent thereof at any time he may choose and in the event of any dispute, the decision of the Engineer-in-charge thereon shall be final and conclusive.

34. EXECUTION OF THE WORK :

The work shall be executed in a workman-like manner and to the satisfaction in all respects of the Engineer-in-charge.

The Engineer-in-charge will communicate or confirm his instructions to the Contractor in respect to the execution of the work in a “ work Site Order Book ” maintained at his office and contractor shall visit this office daily and shall confirm receipt of such instructions by signing the relevant entries in this book. Such entries will rank as order or notices in writing within the intent and meaning of these conditions.



35. DAY WORK :

No day-work shall be performed without the prior written instructions of the Accepting Officer.

The Contractor shall give to the Engineer-in-charge reasonable notice of the start of any work ordered to be executed by day-work and shall deliver to the Engineer-in-charge within two days of end of each pay-week return in duplicate giving full detailed accounts of labour and materials for that pay week. One copy of each of these returns, if found correct, will be certified by the Engineer-in-charge and returned to the contractor and must be produced at the time of adjustment of accounts.

An invoice in duplicate signed by the Contractor or his agent shall be sent with each delivery of materials for day-work and the contractor will be furnished with a receipt signed by the Engineer-in-charge specifying the description, quantities weight or measurement (as the case may be) of the articles approved, reference will be made in this receipt in the return aforesaid and the receipt itself is to be produced in support of the Contractors bill.

In the case of Lump-sum contracts, the rates to be changed and the percentage addition for profit and establishment charges, etc, will be agreed upon between the Accepting Officer and the Contractor prior to the execution of the work.

36. INSPECTION OF THE WORK :

BHEL Officers concerned with the Contractor shall have power at any time to inspect and examine any part of the work and the contractor shall give such facilities as may be required to be given for such inspection and examination.

Should Engineer-in-charge consider at any time during the expiry of maintenance period, that any work has been executed with unsound, imperfect or unskilled workmanship or of quality inferior to that contracted for or not otherwise in accordance with contract (in respect whereof the decision of the Engineer-in-charge. shall be final and conclusive) the contractor shall, on demand in writing from the Engineer-in-charge specifying the fault notwithstanding that the same may have been inadvertently passed, certified and paid for, forthwith rectify or remove and reconstruct the work so specified, in whole or in part as the case may be require at his own expense to the entire satisfaction of the Engineer-in-charge in the event of his failing to do so within a period to be specified by the Engineer-in-charge in his demand aforesaid, the Engineer-in-charge. may carry out the work by other means at the risk and expense in all respect of the contractor. However, the liability of the contractor under this condition shall not extend beyond the maintenance period except as regard workmanship which the Engineer-in-charge shall have previously given notice of to the contractor to rectify.

37. RESPONSIBILITY FOR BUILDING :

In the event of any building, or part of any building being handed over to the Contractor for the execution of work thereto under the provisions of the Contract, he shall give a written receipt for all fixtures, glass etc., and he shall be required to make good at his own expense all damages resulting from any cause whatsoever while in his charge and on completion of the work to deliver up the said building or part thereof a clean state complete in every particular to the entire satisfaction of the Engineer-in-charge.



38. INSURANCE OF WORKS AGAINST DAMAGE AND LOSS DUE TO FIRE, TEMPEST, FLOODS, EARTHQUAKE, RIOT AND AGAINST DAMAGE BY AIR-CRAFT.

The contractor shall, within one month after the date of acceptance of the contract, insure the work against loss and damage by fire, tempest, floods, earthquake, riots and against damage by air-craft with an insurance office approved by the Accepting Officer. Such insurance shall be affected in the name of BHEL and shall be for the full value of the contract sum. The Contractor shall lodge with the BHEL policies and receipt of the premiums for such insurance and shall maintain such policies in force until the entire completion of the work as certified by the Engineer-in-charge.

If the contractor fails to comply with the terms of this condition that the Accepting Officer may insure the work and may deduct the amount of premiums from any money become payable to the contractor or may at his discretion refuse payment of any advances to the Contractor until the contractor shall have complied with the terms of the condition.

Such insurance whether effected by the Accepting Officer or the Contractor shall not be a limit or bar to the liability and obligation of the contractor to complete the entire work in all respects as certified by the Engineer-in-charge.

In case of such a loss or damage as aforesaid, the money payable under any such insurance shall be received and may be retained by the BHEL until the work is finally completed and shall then be credited to the contractor in the final statement of accounts in the event of his contract not having been previously cancelled under these conditions.

39. DAMAGE AND LOSS TO PRIVATE PROPERTY & INJURY TO WORKMAN :

The contractor shall at his own expense reinstate and make good to the satisfaction of the Engineer-in-charge and pay compensation for any injury, loss or damage occasioned to any property or rights whatever including property and rights of BHEL, (or Agents, servants or employees of BHEL) the injury loss or damage arising out of or in any way in-connection with the execution of purported execution of the contract and further the contractor shall indemnify BHEL against all claims enforceable against BHEL (or any agent, servant or employee of BHEL or which would be so enforceable against BHEL) where a private person, in respect of any such injury (including injury resulting in death loss or damage to any person) whosoever or property, including all claims which may arise under the workman's Compensation Act or otherwise.

40. COMPLETION:

The works shall be completed to the entire satisfaction of the Engineer-in-charge and in accordance with the Contractors forecast of Time and Progress where operative, and all unused stores and materials, tools plant, equipment, temporary buildings, and things shall be removed and the site and work cleared of rubbish and all waste materials and delivered up clean and tidy to the satisfaction of the Engineer-in-charge at the Contractors expense on/or before the Scheduled date of completion.

The BHEL shall have power to take over from the Contractor from time to time such sections of the work as have been completed to the satisfaction of the Engineer-in-charge.

The Engineer-in-charge shall certify to the Contractor the date on which the work is completed and the state thereof.



If the contract shall :

- a) Offer or give or agree to give to any person in BHEL, service any gift or consideration of any kind as an inducement or reward for doing or forbearing to do or for having done or forborne to do any act in relation to the obtaining or execution of this or any other contract for BHEL service,

OR

- b) Enter into a contract with BHEL in connection with which commission has been paid or agreed to be paid by him or with his knowledge, unless the particulars of any such commission and the terms of payment thereof have previously been disclosed in writing to the Accepting Officer,

OR

- c) Obtain a contract with BHEL as a result of RING tendering or by non-bonafide methods of competitive tendering without first disclosing the fact in writing to the Accepting Officer.

44. CANCELLATION OF CONTRACT FOR INSOLVENCY, ASSIGNMENT OR TRANSFER OR SUB LETTING OF CONTRACT :

The Accepting Officer, without prejudice to any other right or remedy which shall have accrued or shall accrue thereafter to BHEL shall cancel the contract in any of the following cases:-

If the contractor:

- a) Being an individual, or if a firm any partner thereof, shall at any time be adjusted bankrupt or have a receiving order or orders for administration of his Estate made against him or shall take any proceedings, for liquidation or composition under Bankruptcy Act for the time being in force or make any conveyance or assignment of his effects of composition or arrangements for the benefit of his creditor or purport to do so, or if any application be made under any Bankruptcy Act for the time being in force for the sequestration of his estate or if a trust deed be granted by him on behalf of his creditors;

OR

- b) Being a company, shall pass a resolution or the court shall make an order for the liquidation of its affairs, or a Receiver or a Manager on behalf of the debentures holders shall be appointed or circumstances shall arise which entitle the court or debentures holders to appoint a Receiver or Manager;

OR

- c) Assigns, transfers, sub-let or attempt to assign transfer or sub-let any portion of the work without the prior return approval of the Accepting Officer.

Whenever the Accepting Officer exercise his authority to cancel the contract under this condition he may complete the work by any means at the contractor risk and expense provided always that in the event of the cost of completion (as certified by Engineer-in-charge which is the final and conclusive) being less than the contract cost, the advantage shall accrue to the BHEL and that if the cost of completion exceeds the moneys due to the contractor under the contract, the contractor shall either pay the excess amount ordered by Engineer-in-charge or the same shall be recovered from the contractor by other means.



In case of BHEL completes the work under the provisions of this condition the cost of such completion to be taken into account in determining the excess cost to be charged to the contractor under this condition shall consist of the cost of material purchased and /or labour provided by the BHEL with an addition of such percentage to cover superintendence and establishment charges as may be decided by the Sr. Manager (P) / Engineer-in-charge whose decision shall be final and conclusive.

45 CANCELLATION OF CONTRACT IN PART OR IN FULL FOR CONTRACTOR'S DEFAULT :

If the contractor;

- a) Makes default in commencing the work within a reasonable time form date of handing over of the site and continues in that state after a reasonable notice from Engineer-in-charge

OR

- b) In the opinion of the Engineer-in-charge at any time, whether before or after the date or extended date for completion, make default in proceeding with the work, with due diligence and continues in that state after a reasonable notice from Engineer-in-charge.

OR

- c) Fails of comply with any of terms and conditions of the contract or after reasonable notice in writing with orders properly issued thereunder :

OR

- d) Fails to complete the work, work order and items of work with individual dates for completion and clear the site on or before the date of completion, or fails to achieve the progress as set out under clause 7 of these General Conditions of Contract.

The Accepting Officer may, without prejudice to any other rights or remedies which shall have accrued or shall accrue thereafter to BHEL cancel the contract as a whole or in part thereof or only such work order or items of work in default from the contract. Whenever the Accepting Officer exercises his authority to cancel the contract as a whole or in part under this condition he may complete the work at the contractor risk and cost, provided always that in the event of the cost of completion (as certified by Engineer-in-charge which is final and conclusive) being less than the contract cost, the advantage shall accrue to the BHEL if the cost of the excess amount ordered by Sr. M.P./Engineer-in-charge or the same shall be received from the contractor by other means.

In case the BHEL completes the work or any part thereof under the provisions of this condition the cost of such completion to be taken into account in determining the excess cost to be charged to the contractor under this condition shall consist of the cost of the materials purchased and /or labour provided by the BHEL with an addition of such percentage to cover superintendence and establishment charges as may be decided by the Sr. M.P./ Engineer-in-charge. whose decision shall be final and conclusive.



46 TERMINATION OF CONTRACT FOR DEATH :

Without prejudice to any of the rights or remedies under this contract, if the contractor dies, Accepting Officer shall have the opinion of terminating the contract without compensation to the contractor.

47. SPECIAL POWER OF DETERMINATION:

If at any time after the Acceptance of the tender, BHEL shall for any reason whatsoever not require the whole or any part of the work, to be carried out, the Sr. M.P./Engineer-in-charge shall give notice in writing of the fact to the contractor who shall have no claim to any payment of compensation or otherwise how-so-ever on account of any profit or advantage which he might have derived from the execution of the work in full but which he did not derive in consequence of the force-closing of the work.

He shall be paid at Contract rate, for the full amount of the work executed including such additional works, e.g. clearing of site, etc., as may be rendered necessary by the said force-closing. He shall also be allowed reasonable payment (as decided by the Accepting Officer) for any expenses sustained on account of labour and materials collected but which could not be utilised on the work, as verified the Engineer-in-charge. Neither shall the contractor has any claim for compensation on account of any alterations having been made in the original specifications, drawings, designs and instructions, involving any curtailment of the work as originally contemplated.

48. FAIR WAGE :

- a) The Contractor shall pay not less than the 'Fair Wage' to labourers engaged by him on the work.
'Fair Wage' means wage whether for time or piece work notified at the time of inviting tenders for the work and where such wages have not been notified, the wages prescribed by the Sr. Manager(Projects)/ Engineer-in-charge for the stations at which the work is done.
- b) The contractor shall, notwithstanding the provision of any contract to the contrary, cause to be paid a 'Fair Wage' to labourers indirectly engaged on the work, including any labour engaged by his sub-contractors in connection with the said wok, as if the labourers had been directly employed by him.
- c) In respect of all labours directly or indirectly employed on the work for the performance of the contractor's part of this Agreement, the contractor shall comply with or cause to be complied with the BHEL contractor's labour Regulations (appended hereto as Annexure 'A' to these conditions) in regard to payment of wages, wage period, deductions from wages, recovery of wages, not paid and deductions, unauthorised, maintenance of wage book, wage slips, publication of scale of wages and other terms of employment, inspection and submission of periodical returns and all other matters of a like nature.
- d) The Engineer-in-charge concerned shall have the right to deduct from the moneys due to the Contractor any sum required or estimated to be required for making good the loss suffered by a worker or workers by reason of non-fulfilment of the conditions of the contract for the benefit of the workers, non-payment of wags or of deductions made from this or their wages which are not justified by the terms of the contract or non-observance of the regulations.



- e) Vis-à-vis BHEL, the Contractor shall be liable primarily for all payments to be made under the contract and for the observances of the Regulations aforesaid without prejudice to his right to claim indemnity from his sub-contractors.
- f) The regulations aforesaid shall be deemed to be a part of this contract and any breach thereof shall be deemed to be a breach of this contract.



CHAPTER-IV

VALUATION AND PAYMENT

49. RECORDS AND MEASUREMENTS :

All items having a financial value shall be entered in the BHEL Measurement Book so that a complete record is obtained of all works performed under the contract.

Building etc. priced in schedule 'A' as a unit lump-sum will be entered by number at the unit lump-sum. Work carried out for agreed lump-sums will be described and similarly recorded.

Lump-sum omissions will be entered for deduction. Measurement shall be restricted to that required to ascertain the financial liability of BHEL under the contract.

Work which fails to be measured in detail shall be measured physically, without reference to any local custom that may obtain excepting where it may otherwise be directed in the tender documents. The measurements shall be taken jointly by any person duly authorised on the part of the BHEL and by the contractor.

The Engineer-in-charge shall give reasonable notice in writing to the Contractor of appointment for measurement.

The contractor shall, without extra charge, provide assistance with appliances and other things necessary for measurement.

The Contractor shall bear all the cost of measurement of his work.

Measurement shall be entered in the BHEL Measurement book and signed and dated by both parties each day at the site on completion of measurement. If the contractor objects to any of the measurement recorded on behalf of the BHEL a note to that effect will be made in the BHEL measurement book or against the item or items objected to; and such note shall be signed and dated by both the parties engaged in taking the measurement.

If, as a result of such objection, it becomes necessary to re-measure the work wholly or in part, the expense of such re-measurement shall be borne by the party requiring the measurement to be re-taken provided that a net error is found by this re-measurement to amount to less than 5% (five percent) of the value as recorded by the first measurement. But, where the net errors amount to 5% and over of the said value, then the cost is to be borne by the other party. In any case, if the net value of errors found exceeds Rs. 500/- the expense of re-measurement is to be borne by the other party.

If the Contractors representative fails to attend when required, the Engineer-in-charge shall have power to proceed by himself to take measurements and in that case these measurements shall be accepted by the Contractor as final.

The contractor shall, once every month submit to the Engineer-in-charge with a copy to the Sr. M(P)/ Engineer-in-charge details of his claims for the work done by him upto and including the previous months which are not covered by his contract Agreement in any of the following respects.



- a) Deviation from the items and Specifications provided in the contract documents.
- b) Extra items/New items of work.
- c) Quantities in excess of those provided in the contract schedule.
- d) Items in respect of which rates have not been settled. He should, in addition, furnish a clear certificate to the effect that the claims submitted by him as aforesaid cover all his claims and that no further claims shall be raised by him in respect of the work done upto and including the period under report.

50. VALUATION OF DEVIATIONS :

Rates for deviated items of work will be fixed as follows:

- I. For any item of work required to be carried out after the contract has been awarded and which is not covered by Contractors Schedule but is covered by K.P.W.D. schedule of rates the rate payable for such a fresh item will be derived from K.P.W.D. Schedule by the method of proportion as follows:
 - a) In the same proportion to the rate in K.P.W.D. Schedule of Rates as the tendered rate for the nearest analogous items of work in Contractors Schedule bears to the rate for the particular analogous item or work in K.P.W.D. schedule of Rates.
 - b) If a single appropriate analogous item of work is not available in both Contractor's Schedule and K.P.W.D. Schedule, then the method of proportion will be applied to the nearest analogous group of items available in both the Schedules referred i.e. in the same proportion as the total tendered cost of that particular group of items (the sum of the products of the tendered rates and the quantities for which orders are placed) bears to the total cost of the same items and quantities at the K.P.W.D. Schedule of Rates.
 - c) If even an appropriate analogous group of items is not available in Contractor's Schedule and K.P.W.D. Schedule, then the methods of proportion will be applied to all those items of the whole work, which are available in both the Schedules and for which orders have been placed on the Contractor, i.e., In the same proportion as the total cost of all these items of work (the sum of the products of the tendered rates and the quantities for which orders are placed) bears to the total cost of the same items and quantities at the K.P.W.D. Schedule of Rates.
- II. If any work not covered by any of the foregoing is ordered on the Contractor, the basis of payment shall be decided by the Accepting Officer whose decision shall be final and conclusive and binding on the parties.

The selection of analogous item or analogue group of items referred to above shall be done by the Engineer-in-charge. Where the rates for deviated items or new items of work can be derived by the selection of different analogous items or analogous group of items, the lowest of all such derived rates shall be taken as the correct rate.

In the case of the contracts for which the Engineer-in-charge is the Accepting Officer, all disputes regarding the settlement of rates of deviated or new items of work shall be referred to the Engineer-in-charge. whose decision shall be final and conclusive.



51. REIMBURSEMENT/REFUND ON VARIATION IN PRICE, MATERIALS :

In after submission of the tender and/or during the progress of the works, the price of any materials (not being a material supplied from the BHEL, stores in accordance with the Conditions of the Contract) is increased or decreased by an Act of Legislature (Central or state) and /or any notification thereunder or on account of new duties or levies such as octroi or on account of increase or decrease in such duties affecting the price of materials required for incorporation in the works or the price of any item to be incorporated in the works and made from materials of which the price has increased or decreased as aforesaid and the Contractor has thereupon to pay in respect of such material or item a price which is higher or lower than the price of that material or item as prevailing immediately before the passing of such Act or levying, increasing/decreasing of such duty, the BHEL., shall in case of increase in price or the duty reimburse the Contractor the increase in price or additional increased duty paid by the Contractor and in case of decrease in price, the BHEL shall be entitled to a refund of the reduction in duty. Provided however no reimbursement or refund shall be made if the increase /decrease is not more than plus 10% of the said price, and if so, the reimbursement or refund shall be made only on the excess over 10% provided always that any such increase shall not be payable if, in the opinion of the Engineer-in-charge whose decision shall be final and conclusive the increase is attributable to the delay in the execution of the contract within the control of the Contract, or that any such increase has become operative after the contracted/or extended date completion of the work or items of works in question.

The Contractor shall , for the propose of this condition, keep such books of account and other document as are necessary to show the amount of any increase claimed or any reduction available and shall allow inspection of the same by any duly authorised representative of the BHEL and further shall at the request of the Sr, E/C/E/C. furnish for verification such other information as the Engineer-in-charge may require.

The contractor shall within a reasonable time of his becoming aware of any alteration in the prices of any such materials, give notice thereof in writing to the Engineer-in-charge stating that the rate is submitted in pursuance to this condition together with all information relating there to which he may be in a position to supply.

52. ADVANCES ON ACCOUNT :

No payment shall be made for work estimated to cost less than Rupees One Thousand till after the whole of the work shall have been completed and a certificate of completion given by the Competent authority.

In the case of work estimated to cost more than Rupees One Thousand the contractor may at intervals of not less than one month or as otherwise provided for in the Contract documents, counting from the date on which order to commence work given by Engineer-in-charge submit claims on BHEL forms for payment of advance on account of work done and of materials delivered in connection with the Contract.

The Contractor shall be paid in respect of such claims to the extent approved and passed by the Engineer-in-charge subject to a maximum of 90% of the value of the work actually executed in site provided the work has been executed to the satisfaction of the Engineer-in-charge. The certificate of the Engineer-in-charge regarding such approval and passing of the sums so payable shall be final and conclusive against the Contractor.



“After the full amount of Security Deposit is made up through the 10% deductions from ‘On Account’ bills, 100% of all subsequent bills may be made to the Contractor”.

The Contractor may also be paid during the progress of the work 75% of the value of any materials which are in the opinion of the Engineer-in-charge in accordance with contract, and are actually required for incorporation in the work and which have reasonably been brought to the site in-connection therewith and are adequately stored and/or protected against damage by weather or other causes, but which have not at the time of payment of the advance been incorporated in the work. Payment of such advances however shall be purely at the discretion of the Engineer-in-charge provided always that payments shall not be made under these periodical certificates in respect of perishable materials like lime, cement, timber, sand kankar etc.

Any sums/due from the Contractor on account of tools and plant, stores or any other items provided by BHEL shall be deducted from the respective advances.

The Engineer-in-charge shall from time to time certify the sums payable to the Contractor after retaining the reserves.

Any certificate relating to work done or materials delivered may be modified or corrected by any subsequent interim certificate or by the final certificate and no certificate of the Engineer-in-charge supporting an advance payment shall itself be conclusive evidence that any work or materials to which it relates are in accordance with the contract. All such intermediate payments shall be regarded as advances against the final payment only and shall not be considered as an admission of the due performance of the contract or any part thereof in respect or the accruing of any claim whatsoever. Such intermediate payments shall not conclude, determine or effect in any way the powers of the Engineer-in-charge as to the final settlement and adjustment of the account or otherwise, or in any way vary or affect the Contract.

53. FINAL BILL :

As soon as possible after the completion of the work to the satisfaction of the Engineer-in-charge, the contractor shall forward a certified final account on BHEL forms, in duplicate. It shall be accompanied by all abstracts, vouchers etc., in support thereof and shall be prepared in the manner prescribed by the Engineer-in-charge. No claim will be entertained after the receipt of the final bill.

The contractor shall be entitled to be paid the final sum less the value of payments already made on account, subject to certification of the final bill by the Engineer-in-charge any sums due from the contractor on account of Tools and plant, Stores or any other items provided by BHEL not yet recovered from the contractor shall be deducted from the final sum aforesaid.

No charge shall be allowed to the contractor on account of the preparation of the final bill.



54. PAYMENT OF BILLS :

All payments to be made to the Contractor under this contract shall be by “Crossed Cheque” marked “A/C payee only” (within a reasonable time after the certification by the Engineer-in-charge at the..... located in the station where either the work is executed or service rendered or at their branch nearest to the station where the Office of the Engineer-in-charge is located.)

55. RECOVERY FROM CONTRACTOR :

Whenever under the contract any sum of money shall be recoverable from or payable by the contractor the same may be deducted from any sum then due or which at any time thereafter may become due to the contractor under the contract or under any other contract with BHEL or from his Security Deposit or he shall pay the claim on demand.

56. POST TECHNICAL AUDIT OF WORK AND BILLS :

BHEL reserves the right to carry out a post-payment audit and technical examination of the work and final bill including all supporting vouchers, abstract etc., and to enforce recovery of any sums becoming due as a result thereof in the manner provided in the preceding sub-paragraph’s provided however that no such recovery shall be enforced after three years of passing the final bill.

57. REFUND OF SECURITY DEPOSIT :

50% of the Security Deposit mentioned in condition 16 above, may be refunded to the contractor in respect of all contracts on completion of work and after payment of final bill and the balance 50% on expiry of the maintenance period, (Described under clause 23) provided the contractor shall have rendered a “ No Demand Certificate.” In case of works where maintenance period is not involved 100% of the security deposit may be refunded after payment of final bill provided that the contractor shall have rendered a “ No Demand Certificate.”

58. ARBITRATION :

Except where otherwise provided for in the contract all question and disputes relating to the meaning of the specifications, design, drawings and instructions herein before mentioned and as to the quality of workmanship or materials used on the work or as been other questions, claim, right, matter or things whatsoever in any way arising out of or relating to the contract, design, drawing, specification, estimates, instructions, orders or these conditions or otherwise concerning the works or the execution or failure to execute the same whether arising during the program of the work or after the completion or abandonment thereof shall be referred to the sole arbitration of the Managing Director/Chief Engineer of BHEL and if the Managing Director/Chief Engineer is unable or unwilling to Act, to the sole arbitration of some other person appointed by the Managing Director/General Manager/Chief Engineer, willing to Act as such arbitrator. The cases referred to arbitration shall be other than those for which the decision of the Engineer-in-charge. is expressed in the contract to be final and conclusive. There will be no objection if the arbitrator so appointed is an employee of BHEL and that he



had to deal with the matters to which the contract relates and that in the course of his duties as such he had expressed views on all or any of the matters in dispute or difference. The arbitrator to whom the matter is originally referred being transferred by vacating his office or being unable to act for any reason, such Managing Director/ General Manager/Chief Engineer as aforesaid at the time of such transfer, vacation of office or inability to act, shall appoint another person to act as arbitrator in accordance with the terms of the contract, such person shall be entitled to proceed with the reference from the state at which it was left by his predecessor.

Subject as aforesaid the provision of the Arbitration Act, 1940 or any statutory modification or re-enactment thereof and the rules made thereunder and for the time being in force shall apply to the arbitration proceedings under this clause.

It is a term of contract that the party involving arbitration shall specify the dispute or disputes to be referred to arbitration under this clause together with the amount or amounts claimed in respect of each such dispute.

The arbitrator (s) may from time to time with consent of the parties enlarge the time, for making and publishing the awards.

The work under the contract shall, if reasonably possible, continue during the arbitration proceedings and no payment due to payable to the contractor shall be withheld on account of such proceedings.

The Arbitrator shall be deemed to have entered on the reference on the date he issues notice to both the parties fixing the date of the first hearing.

The Arbitrator shall give a separate award in respect of each dispute or difference referred to him.

The venue of arbitration shall be such place as may be fixed by the arbitrator in his sole discretion.

The award of the arbitrator shall be final, conclusive and binding all parties to this contract.



ANNEXURE- 'A'

BHEL CONTRACTOR'S LABOUR REGULATIONS.

(See condition 20)

1. DEFINITION:

In these regulations, unless otherwise expressed or indicated, the following words and expressions shall have the meaning hereby assigned to them.

- a) " Labour " means workers employed by a contractor directly or indirectly through a sub-contractor, or by an agent on his behalf on a payment not exceeding Rs. 500/- per month.
- b) " Fair Wage " means wages, which shall include wages for weekly day of rest and other allowances, whether for time or piece work, after taking into consideration prevailing market rates for similar employment in the neighborhood but shall not be less than the minimum rates of wages fixed under the Minimum wages Act.
- c) " Contractor " for the purpose of these Regulations shall include an agent or sub-contractor employing labour on the work taken on contract.
- d) " Inspecting Officer " means any Labour Enforcement Officer or Assistant Labour Commissioner of the Chief Labour Commissioner's organisation.
- e) " Form " means a form appended to these Regulations.

2. NOTICE OF COMMENCEMENT:

The contractor shall, within seven days of commencement of the work, furnish in writing to the Inspecting Officer of the area concerned the following information, with copy to the Engineer- in-charge.

- a) Name and situation of the work.
- b) Contractor's name and address.
- c) Particulars of the Department for which the work is undertaken.
- d) Name and address of the sub-contractors as and when they are appointed.
- e) Commencement and probable duration of the work.
- f) Number of workers employed and likely to be employed.
- g) 'Fair Wages' for different categories of workers.

3. I) Number of hours, which shall constitute a normal working day. The number of hours which shall constitute a normal working day for an adult shall be NINE hours. The working day of an adult worker shall be so arranged that of intervals, if any for rest it shall not spread over more than 12 hours on any day, when an adult worker is made to work for more than NINE hours on any day or for more than 48 hours in any week he shall in respect of over time work, be paid wages at double the ordinary rate of wages.

II) Weekly day of rest: Every worker shall be given a weekly day of rest, which shall be fixed and notified at least 10 days in advance. A worker shall not be required or allowed to work on the weekly rest day unless he has or will have a substitution rest day, on one of the five days immediately before or after the rest day, provided that no substitution shall be made which will result in the worker working for more than 10 days consecutively without a rest day for a whole day.

Where in accordance with the foregoing provisions a worker works on the rest day and has been given a substituted rest day he shall be paid wages for the work done on the weekly rest day at the overtime rate of wages.

NOTE: The expression ' Ordinary rate of wages ' means the fair wage the worker is entitled to.



4. DISPLAY OF NOTICE REGARDING WAGES, WEEKLY DAY OF REST ETC.

The Contractor shall before he commences his work on contract display and correctly maintain and continue to display and correctly maintain in a clean legible condition in conspicuous places on the works, notice in English and in the local Indian languages, spoken by majority of workers, giving the rate of fair wages, the hours of work for which such wages are payable, the weekly rest days workers are entitled to and name and address of the Inspecting Officer. The Contractor shall send a copy of each of such notice to the Inspecting Officers and the Engineer- in- charge.

5. FIXATION OF WAGE PEIODS:

The contractor shall fix wage periods in respect of which wages shall be payable. No wage period shall normally exceed one work.

6. PAYMENT OF WAGES:

- i) Wages due to every worker shall be paid to him direct. All wages shall be paid in current coins or currency or in both.
- ii) Wages of every worker employed on the contract shall be paid where the wage period is one week ,within three days from the end of the wage period, and in any other case before the expiry of the 7th day or 10th day from the end of the wage period according as the number of workers does not exceeds 1000.
- iii) When employment of any worker is terminated by or on behalf of the contractor, the wages earned by him shall be paid before expiry of the day succeeding the one on which his employment is terminated.
- iv) Payment of wages shall be made at the work site on a working day except when the work is completed before expiry of the wage period, in which case final payment shall be made at the work site with in 48 hours of the last working day and during normal working time.

Note:

The term “working day” means a day on which the work, on which labour is employed, is in progress .

7. REGISTER OF WORKMEN:

A register of workmen shall be maintained in the form appended to these regulations and kept at the work site or as near to it as possible, and the relevant particulars of every workmen shall be entered therein within 3 days of his employment.

8. EMPLOYMENT CARD:

The contractor shall issue an employment card in the form appended to these regulations to each worker on the day of work or entry into his employment. If a worker has already any such card with him issued by the previous employer the contractor shall merely endorse that employment card with relevant entries. On termination of employment the employment card shall again be endorsed by the contractor and returned to the worker.

9. REGISTER OF WAGES ETC :

- i) A register of wages- cum-muster roll in the form appended to these regulations shall be maintained and kept at the work site or as near to it as possible.
- ii) A wage slip in the form appended to these regulations shall be issued to every worker employed by the contractor atleast a day prior to disbursement of wages.



10. FINES AND DEDUCTIONS WHICH MAY BE MADE FROM WAGES:

- i) Wages of worker shall be paid to him without any deductions of any kind except the following:
 - a) Fines.
 - b) Deductions for absence from duty, i.e. from the place or the places where by the terms office employment is required to work. The amount of deduction shall be in proportion to the period for which he was absent.
 - c) Deduction for damage to or loss of goods expressly entrusted to the employed person for custody, or for less of money which he is required to account for, where such damage or loss is directly attributable to his neglect or default ;
 - d) Deductions for recovery of advances or for adjustment of over payment of wages. Advances granted shall be entered in a register ; and
 - e) Any other deduction which the BHEL may from time to time allow.
- ii) No fines shall be imposed on a worker save in respect of such acts and omissions on his part as have been approved by the chief Labour Commissioner.
- iii) No fines shall be imposed on a worker and no deductions for damage for loss shall be made from his wages until the worker has been given an opportunity of showing – cause against such fines or deductions.
- iv) The total amount of fines which may be imposed in any one wage period on a worker shall not exceed an amount equal to three paise in a rupee of the wages payable to him in respect of that wage period.
- v) No fine imposed on a worker shall be recovered from him in instalments, or after expiry of sixty days from the date on which it was imposed. Every fine shall be deemed to have been imposed on the day of the act or omission in respect which it was imposed.
- vi) The contractor shall maintain both in English and the local Indian language a list, approved by the Chief Labour Commissioner, clearly stating the acts and omissions for which penalty or fine may be imposed on a workman and display it in good condition in a conspicuous place on the work site.
- vii) The contractor shall maintain a register of fines and the register of deductions for damage or loss in the forms appended to these regulations which should be kept at the place of work.

11. REGISTER OF ACCIDENTS:

The contractor shall maintain a register of accidents in such form as may be convenient at the work place but the same shall include the following particulars :-

- a) Full particulars of the labourers who met with the accident.
- b) Rates of wages
- c) Sex.
- d) Age.
- e) Nature of accident and cause of accident.
- f) Time and date of accident.
- g) Date and time when admitted in hospital.
- h) Date of discharge from the hospital.
- i) Period of treatment and result of treatment.
- j) Percentage of loss of earning capacity and disability as assessed by Medical officer.
- k) Claim required to be paid under workmen's composition Act.



- l) Date of payment of compensation.
- m) Amount paid with details of the person to whom the same was paid.
- n) Authority by whom the compensation was assessed.
- o) Remarks.

12. PRESERVATION OF REGISTERS:

The register of workmen and the Register of wages-Cum-Muster Roll required to be maintained under these Regulations shall be preserved for 3 years after the date on which the last entry is made therein.

13. ENFORCEMENT:

The Inspecting Officer shall either on his own motion or on a complaint received by him carry out investigations and send a report to the Engineer-in-charge specifying the amount representing / workers dues and amount of penalty to be imposed on the contractor for breach of these regulations, that have to be recovered from the contractor, indicating full details of the recoveries proposed and the reasons, therefor. It shall be obligatory on the part of the Engineer-in-charge on receipt of such a report to deduct such amounts from payments due to the contractor.

14. DISPOSAL OF AMOUNTS RECOVERED FROM THE CONTRACTORS:

The engineer- in -charge shall arrange payment to workers concerned within 45 days from receipt of a report from the Inspecting Officer except in cases where the contractor had made an appeal under regulation. 16. Of these regulations. In cases where there is an appeal, payment of worker dues would be arranged by the Engineer -in -charge, wherever such payments arise, with in 30 days from the date of receipt of the decision of the Regional Labour Commissioner (RLC).

15. WELFARE FUND :

All moneys that are recovered by the Engineer-in-charge by way of workers due which could not be disbursed to workers with in the time-limit prescribed above, due to reasons such as where about or workers not being known, death of a worker, etc., and also amounts recovered as penalty, shall be credited to a fund to be kept under the custody or BHEL for such benefits and welfare of workmen employed by the contractors.

16. APPEAL AGAINST DECISION OF INSPECTING OFFICER:

Any person aggrieved by a decision of the Inspecting Officer may appeal against such decision to the Regional Labour Commissioner concerned within 30 days from the date of decision, forwarding simultaneously a copy of his appeal to the Engineer-in-charge. The decision of the Regional Labour Commissioner Shall be final and binding upon the contractor and the work men.

17. REPRESENTATION OF PARTIES :

- i) A workman shall be entitled to be represented in any investigation or enquiry under these Regulations by an officer of a registered trade union of which the said trade union is affiliated or where the work man is not a member of any registered trade union, by an officer of a registered trade union, connected with, or any other workmen employed in, the industry in which the worker is employed.
- ii) A contractor shall be entitled to be represented in any investigation or enquiry under these Regulations by an officer of an association of contractors of which he is member or by an officer of a Federation of associations of contractors to which the said association is affiliated



or where the contractor is not a member of any association of employers, connected with, or by any other employer engaged in the industry in which the contractor is engaged.

- iii) No party shall be entitled to be represented by a legal practitioner in any investigation or enquiry under these Regulations.

18. INSPECTION OF BOOKS AND OTHER DOCUMENTS:

The contractor shall allow Inspection of the registers and other documents prescribed under these regulations by inspecting officers and the Engineer-in-charge or his authorised representative at any time and by the worker or his agent on receipt of due notice at a convenient time.

19. INTERPRETATION ETC. :

On any question as to the application, interpretation or effect of these Regulations, the decision of the Chief Labour Commissioner or Deputy Chief Labour Commissioner (Central) shall be final and binding.

20. AMENDMENTS :

Central Government may, from time to time, add to or amend the Contractors Labour Regulations and issue such directions as it may consider necessary for the proper implementation of the Contractors Labour Regulations for the purpose of removing any difficulty which may arise in the administration thereof, based on which the BHEL Contractors Labour Regulation here in contained shall be subject to revision.



BHEL SAFETY CODE

(See condition 20)

1. Suitable scaffolds shall be provided for workmen for all work that cannot safely be done from the ground, or from solid construction except such short period work as can be done safely from ladders. When a ladder is used one extra mazdoor shall be engaged for holding the ladder and if the ladder is used for carrying materials as well, suitable footholds and handholds shall be provided on the ladder and the ladder shall be given an inclination not steeper than $\frac{1}{4}$ to 1 (1/4 horizontal and 1 vertical).
2. Scaffolding or staging more than 3.25 meters above the ground or floor, swing or suspended from an overhead support or erected with stationery support, shall have a guard rail properly attached, bolted, braced and otherwise secured atleast 1 meter high above the floor or platform of such scaffolding or staging and extending along with the entire length of the outside and ends thereof with only such openings as may be necessary for the delivery or materials, such scaffolding or staging shall be so fastened as to prevent it from swaying from the building or structure.
3. Working platform, gangways and stairways shall be so constructed that they do not sag unduly or unequally, and if height of a platform or gangway or stairway is more than 3.25 meters above ground level or floor level it shall be closely boarded, have adequate width and be suitably fenced, as described in 2 above.
4. Every opening in floor of a building or in a working platform shall be provided with suitable means to prevent fall of persons or materials by providing suitable fencing or failing with a minimum height of 1 meter.
5. Safe means of access shall be provided to all working platform and other working places, Every ladder shall be securely fixed. No portable single ladder shall be over 9 meters in length. Width between side rails in a rung ladder shall in no case be less than 30cm. For ladders upto and including 3 meters in length. For longer ladders this width shall be increased by atleast 6mm for each additional 30 cms of length. Uniform step spacing shall not exceed 30 cm.

Adequate precautions shall be taken to prevent danger from electrical equipment. No materials on any of the sites shall be so stacked or placed as to cause danger or inconvenience to any person or the public. The contractor shall provide all necessary fencing and lights to protect public from accidents and shall be bound to bear expenses of defence of every suit action or other proceedings at law that may be brought by any person for injury sustaining owing to neglect of the above precautions, and pay any damages and costs which may be awarded in any such suit, action or proceedings to any such person or which may with the consent of the contractor be paid to compromise any claim by any such person.

6. EXCAVATION AND TRENCHING :

All trenches, 1.5 meters or more in depth, shall at all times be supplied with atleast one ladder for each 30 m length or fraction thereof. Ladder shall to be extended from bottom of trench to atleast, 1 meter above surface of the ground. Sides of a trench 1.5 meters or more in depth shall be stepped back to give suitable slope, or securely held by timber bracing, so as to avoid the danger of sides collapsing. Excavated materials shall not be placed within 1.5 meters of the edge of trench or half the depth of trench, whichever is more. Cutting shall be done from top to bottom. Under no circumstances shall undermining or undercutting be done.

7. DEMOLITION:

Before any demolition work is commenced and also during the process of the work.

- a) All roads and open areas adjacent to the work site shall either be enclosed or suitably protected;



- b) No electric cable or apparatus which is liable to be source of danger over a cable or apparatus used by operator shall remain electrically charged.
- c) All present steps shall be taken to prevent danger to persons employed, from risk or fire or explosion or No floor, roof or other part of a building shall be so overloaded with debris or materials as to render it unsafe.
8. All necessary personal safety equipment as considered adequate by the Engineer-in-charge shall be available for use of persons employed on the site and maintained in a condition suitable for immediate use and the contractor shall take adequate steps to ensure proper use of equipment by those concerned.
 - a) Workers employed on mixing asphaltic materials cement and lime mortars/concrete shall be provided with protective footwear and protective goggles.
 - b) Those engaged in handling any materials which is injurious to the eye shall be provided with protective goggles.
 - c) Those engaged in welding works shall be provided with welder's protective eye shields.
 - d) Stone breaker shall be provided with protective goggles and protective clothing and seated at sufficiently safe intervals.
 - e) When workers are employed in sewer and manholes which are in use, the contractor shall ensure that manholes covers are opened and manholes are ventilated at least for an hour before workers are allowed to get in to them. Manholes so opened shall be cordoned off with suitable railing and provided with warning signals or boards to prevent accident to public.
 - f) The contractor shall not employ men below the age of 18 and women on the work of painting with products containing lead in any form. Wherever men above the age of 18 are employed on the work of lead painting the following precautions shall be taken.
 - i) No paint containing lead or lead products shall be used except in the form of paste or readymade paint.
 - ii) Suitable face masks shall be supplied by the contractor for use by workers when paint is applied in the form of spray or a surface having lead paint is dry rubbed and scrapped.
 - iii) Overalls shall be supplied by the Contractor to workmen and adequate facilities shall be provided to enable working painters to wash during and cessation of work.
9. When work is done near any where there is risk of drowning, all necessary equipment shall be provided and kept ready for use and all necessary steps taken for prompt rescue of any person in danger and adequate provision made for prompt first aid treatment of all injuries likely to be sustained during the course of the work.
10. Use of hoisting machine and tackles including their attachments, anchorage and supports shall conform to the following:
 - a)
 - i) These shall be of good mechanical construction, sound material and adequate strength and free from defects.
 - ii) Every rope used in hoisting or lowering materials or as a means of suspension shall be durable quality and adequate strength, and free from defects.
 - b) Every crane driver or hoisting appliance operator shall be properly qualified and no person under the age of 21 years shall be in-charge of any hoisting machine including any scaffolding winch or give signals to operator.
 - c) In case of every hoisting machine and of every chain, ring, hook, shackle, swivel and pulley block used in hoisting, or lowering or as means of suspension safe working load shall be ascertained by adequate means. Every hoisting machine and all gear referred to above shall have the safe working load plainly marked thereon. In case of a hoisting machine having a variable safe working load, each safe working load, and the conditions under which it is



- applicable shall be clearly indicated. No part of any machine or any gear referred to above in this paragraph shall be loaded beyond the safe working load except for the purpose of testing.
- 10.d) In case of departmental machine, safe working load shall be notified by the Engineer-in-charge. As regards contractor's machines the contractor shall notify safe working load of each machine to the Engineer-in-charge whenever he brings it to site of work and get it verified by the Engineer-in-charge.
11. Motors gearing, transmission, electric wiring and other dangerous parts of hoisting appliances shall be provided with efficient safeguards, hoisting appliances shall be provided with such means as will reduce to the minimum risk of accidental descent of load. Adequate precautions shall be taken to reduce to the minimum risk of any part of a suspended load becoming accidentally displaced. When workers are employed on electrical installations which are already energised, insulating mats, working apparel such as gloves, sleeves, and boots, as may be necessary shall be provided. Workers shall not wear any rings, watches carry keys or other materials which are good conductors of electricity.
12. All scaffolding, ladders and other safety devices mentioned or described herein shall be maintained in a safe condition and no scaffold, ladder or equipment shall be altered or removed while it is in use. Adequate washing facilities shall be provided at or near the places of work.
13. These safety provisions shall be brought to the notice of all concerned by display on a notice board at a prominent place at the work spot. Persons responsible for ensuring compliance with the safety code shall be named there on by the contractor.
14. To ensure effective enforcement of the rules and regulations relating to safety precautions, arrangements made by the contractor shall be open to inspection by the Engineer-in-charge or his representative and the inspection officers as defined in the contractor's Labour Regulations.
15. Notwithstanding the above conditions 1 to 14, the Contractor is not exempted from the operation of any other Act or Rule in force.



FROM OF REGISTER OF WORKMEN
(Regulation 7)

- (i) Name and address of the contractor :.....
- (ii) Number and date of the contract agreement/work order :.....
- (iii) Name and address of the department awarding the contract:.....
- (iv) Nature of the contract and location of the work:.....
- (v) Duration of the contract :.....

Sl.No	Name and Surname of the workers	Age & Sex	Father's Husband's Name	Nature of employment designation.	Permanent/home address of employee (village Dist. Tana)	Present address.	Date of commencement of employment	Date of termination or leaving of employment	Signature or thumb impression of the employee	Remarks.
1	2	3	4	5	6	7	8	9	10	11



FORM OF EMPLOYMENT CARD (Regulation 8)

- (i) Name and sex of the worker :.....
- (ii) Father's/Husband's Name :.....
- (iii) Address :.....
- (iv) Age or date of birth :.....
- (v) Identification marks :.....

Particulars of next of kin (wife/husband and children, if any, or/dependant next of kin in case the worker has no wife/husband or child) :
 Name :.....
 Full address of dependants :.....
 (Specify village, Dist., and State) :.....

Sl.No	Name and address of Employer (specify whether a contractor or a sub- contractor).	Particulars of location of work site and description of work done.	Total period for which the worker is employed (from- to)	Actual Number of days worked	Leave taken (No. of days should be specified)	Nature of work done by the worker	Wage rate with particulars of unit in case piece-work	Total wages earned by the worker during the period shown under col.5.	Remarks	Signature of the employer.
1	2	3	4	5	6	7	8	9	10	11

N.B. for a worker employed at one time one piece-work basis and at another on daily wages, relevant entries in respect of each type of employment should be made separately.



**FORM OF WAGE SLIP
 (REGULATION 9)**

(i) **Name of the contractor**.....
 (ii) **Place**.....

- 1. **Name of the workers with father's/husband's Name** :
 - 2. **Nature of employment** :
 - 3. **Wage period** :
 - 4. **Rate of wages payable** :

 - 5. **Total attendance/unit of work done** :

 - 6. **Dates on which overtime Worked.** :

 - 7. **Overtime wages.** :

 - 8. **Gross Wages payable** :

 - 9. **Total deductions (indicating nature of deduction).**

 - 10. **Net Wages Payable** :
-

**CONTRACTOR'S SIGNATURE/
 THUMB IMPRESSION.**

**EMPLOYEES SIGNATURE/
 THUMB IMPRESSION.**



FORM OF RESISTER OF WAGES-CUM-MUSTER ROLL

(Regulation 9)

- (i) Name and address of the contractor:.....
- (ii) No. & Date of the contract agreement/work order :.....
- (iii) Name and address of the dept. awarding the contract :.....
- (iv) Nature of the contract and location of the work :.....
- (v) Duration of the contract :.....
- (vi) Wage period :.....

							Fair wages payable.		Wages paid .		Overtime worked.			Deduction from wages.									
Serial Number	No. and Surname of the worker.	Father's/husband's Name	Sex	Designation nature of work.	Daily attendance (No. of units worked)	Total attendance units.	Basic	D.A.and other allowances	Basic	D.A.and other allowances	Date	No. of hours.	Over time wages earned .	Total wages paid	Fine	Deduction for damage or loss	House rent.	Revenue of advances.	Other deductions	Net wages payable.	Date of payment	Signature or thumb impression	Remarks.
1	2	3	4	5	6	7	8	9	10	11	12	13	14	15	16	17	18	19	20	21	22	23	24



**FORM OF REGISTER OF
DEDUCTIONS FOR DAMAGE OR LOSS CAUSED TO THE BHEL BY THE NEGLIGENCE OR
DEFAULT OF THE EMPLOYED PERSONS.**

(Regulation No. 10 (vii)).

Sl.No	Name	Father's/ Husband's Name.	Sex.	Dept	Damage or loss caused with date.	Whether worker showed cause against deduction if so, enter date.	Date and amount of deduction imposed.	Number of instalment if any.	Date on which total amount realised	Remarks.
1	2	3	4	5	6	7	8	9	10	11



FORM OF REGISTER OF FINES (REGULATIONS No. 10 (VII))

Sl.No.	Name	Father's/ Husband's Name.	Sex.	Dept.	Nature and date of the offence for which fine imposed	Whether workman showed cause against fine or not, enter date.	Rate of wages .	Date and amount of fine imposed.	Date on which fine realised.	Remarks.
1	2	3	4	5	6	7	8	9	10	11



Bharat Heavy Electrical Ltd
Electronics Division
Mysore Road, Bangalore-560026

Price Bid
for the work of:

"AIR CONDITIONING SYSTEM FOR BUILDING NO.18"

Issued to: M/S

Bill of Quantities

Notes :-

- 1 All items of work under this Contract shall be executed strictly to fulfill the requirements laid down under "Basis of Design" in the specifications. Type of equipment, material specifications, methods of installation, testing, and type of controls shall be in accordance with the Specifications, the relevant BIS codes and other Standards and approved shop Drawings i.e. detailed fabrication drawings of various sizes of ducts / pipes and all associated accessories keeping in view the final commissioning and air / water balancing of the installation to give specified performance. However, capacity of each component and their quantities shall be such as to fulfill the above-mentioned requirement.
- 2 The rate for each item of work included in the Schedule of Quantities shall, unless expressly stated otherwise, include cost of :
 - a. All materials, fixing materials, accessories, appliances, tools, plants, equipment, transport, labour and incidentals required in preparation for and in the full and entire execution, testing, balancing, commissioning and completion of the work called for in the item and as per specifications and Drawings.
 - b. Wastage on materials and labour.
 - c. Customs clearance, loading, transporting, unloading, handling / double handling, hoisting to all levels, setting, fitting and fixing in position, protecting, disposal of debris and all other labour necessary in and for the full and entire execution and to fully complete the work in accordance with the contract documents, good practice and recognized principles.
 - d. Liabilities, obligations and risks arising out of Conditions of Contract.
 - e. All requirements of Specifications, whether such requirements are mentioned in the item or not. The Specifications and Drawings where available, are to be read as complimentary to and part of the Schedule of Quantities and any work called for in one shall be taken as required for all.
- 3 In the event of conflict between Schedule of Quantities and other documents including the Specifications, the most stringent shall apply and the interpretation of BHEL /Owner shall be final and binding.
- 4 All equipment, quantities and technical data indicated in this Schedule are for the Contractor's guidance only; This Schedule must be read in conjunction with these documents. The Contractor shall be paid for the actual quantity of work executed by him in accordance with the approved Shop Drawings at the contract rates and the actual measurement. All measurements for ducts & insulation, pipes and insulated pipes, fittings, bends and valves etc. shall be taken along the center line.
- 5 The quantities given in this schedule are provisional, BHEL reserves the right to increase or decrease the quantities of work or to totally omit any items of work and the Contractor shall not be entitled to claim any extras or damages on these grounds. These variations shall be permitted until such time Contractor's shop drawings are approved. For items with variable quantities, the payment will be made on the basis of actual quantity executed at site.

- 6 This Schedule of Price Bid shall be fully priced and the extensions and totals duly checked. The rates for all items shall be filled in same ink.
- 7 No alteration whatsoever is to be made to the text or quantities of this Schedule unless such alteration is authorized in writing by BHEL. Any such alterations, notes or additions shall, unless authorized in writing, be disregarded when tender documents are considered.
- 8 In the event of an error occurring in the amount column of the Schedule, as a result of wrong extension of the unit rate and quantity, the unit rate quoted by the Tenderer shall be regarded as firm and the extensions shall be amended on the basis of the rates.
- 9 Any errors in totaling in the amount column and in carrying forward totals shall be corrected. Any error, in description or in quantity or omission of items from this schedule shall not vitiate this Contract but shall be corrected and deemed to be a variation required by Owners.
- 10 Rates quoted for all items in BOQ shall be on indivisible works contract basis and shall include excise duty, customs duty, sales tax, octroi, transportation, works contract tax or any other taxes.
- 11 Generally, no foreign exchange or assistance for import of any equipment / component shall be provided by BHEL. It shall be Contractor's responsibility.
- 12 The drawings accompanying the tender shall be read in conjunction with Architectural / Structural drawings.
- 13 Owners reserve the right to get any equipment / material tested / checked, before accepting its delivery at site or at original manufacturers works or at any approved Govt. laboratory at Contractor's cost to establish conformity of quality / rating with tender specifications and the entire cost in this regard will be borne by the Contractor.
- 14 Samples of material / equipments / controls etc as required by the Engineer-in-Charge will be submitted for approval before delivering the equipment / material at site. No material / equipment will be delivered without approval of the sample.
- 15 Actual execution of work will start only after approval of Contractor's shop drawings.
- 16 Buried pipes crossing roads / hard /finished floorings will be provided with adequate retaining brick walls on side and RCC slab on the top to protect the pipes from any damage due to movements of heavy vehicles etc.
- 17 The prices are to be quoted in the BOQ format given herewith and shall include, as also mentioned above, the supply, installation, testing and commissioning at site, of all the equipments, ancillary materials as specified and shall be inclusive of all taxes, duties etc at the prevailing rates and all such items whatsoever which may be required to fulfil the intent and purpose as laid down in the specification and/or the drawings.

Bill of Quantities
AIR CONDITIONING SYSTEM FOR BUILDING NO. 18.

Sl.no.	DESCRIPTION	UNIT	QTY	RATE	Amount (C)=(A x B)	K-VAT/WCT	SERVICE TAX	Total Amount (F)=(C + D+ E)
			(A)	(B)	(C)	(D)	(E)	(F)
1	DX AIR HANDLING UNITS Supply, Installation, Testing & commissioning of Horizontal type Double Skin DX Air Handling units of Capacity:- Air Volume 12500 CFM ,External Static Pressure 50 MM WG of 33 TR with DX-Coil suitable for R407C/R134-a/R410a Eco-Friendly refrigerant & Thermostatic Expansion Valve with 10 Micron pre-Filter efficiency 90% (As per details in Scope Of Work/Specification).	Set	3					
2	CONDENSING UNITS:- Supply, Installation, testing & commissioning of Air cooled Condensing units(Outdoor Units) of 11 TR Capacity with Scroll Compressors suitable for Eco-Friendly refrigerant R407C/R134-a/R410a with Condenser Coil & fans.(As per details in Scope of Work/Specification)	Set	9					
3	Eco-Friendly Refrigerant gas R407C/R134-a/R410a	kg	200					
4	Supply, Installation, Testing & commissioning of suitable diameter HD copper refrigerant piping between DX AHU and condensing units with Nitrile Rubber Insulation. (1RMT will be calculated as one Meter of suction line and one Meter of Liquid line each along with insulation Taken together.) Measurement shall be taken between the outlet of the units.	Rmt	225					
5	Supply, fabrication and erection of rectangular GI ducting with necessary MS flanges, suspension rods, anchor bolts, bolts, nuts and supports.							
a	18G(for Plenum)	Sqm	80					
b	20G	Sqm	140					
6	Supply and fixing of 25mm thick acoustic glass wool insulation of 32Kg/Cu.m density with R.P.Tissue paper, 26G perforated aluminium sheet etc.	Sqm	80					
7	Supply and fixing of Nitrile rubber insulation with Al foil on exposed surface for Supply and Return Rectangular air duct (For Supply Air Duct from Plenum to Spiral Duct and for Return Air Duct from Catering area to AHU room.							
a	Nitrile Rubber Insulation of thickness not less than 18mm for supply air	Sqm	50					
b	Nitrile Rubber Insulation of thickness not less than 12mm for Return air	Sqm	90					
8	Supply, Fabrication, erection and painting of Pre Fabricated Spiral/Elliptical GI ducting with necessary vanes, flanges, suspension rods, anchor bolts, bolts, nuts and supports.							
a	22G	Sqm	200					
b	24G	Sqm	150					
9	Supply, Installation, Testing and commissioning of G.I Back Draft Damper	Sqm	5					
10	Supply, Installation, Testing and commissioning of Flexible Canvas Connection	Nos	3					
11	Supply, Installation, Testing and commissioning of G.I Volume control damper	Sqm	3					
12	Supply, Installation, Testing and commissioning of G.I Fire damper with fusible plug	Sqm	3					
13	Supply Installation of aluminium extruded supply air grills with collar damper	Sqm	8					
14	Supply Installation of aluminium extruded Return air grills	Sqm	4					

Sl.no.	DESCRIPTION	UNIT	QTY	RATE	Amount (C)=(A x B)	K-VAT/WCT	SERVICE TAX	Total Amount (F)=(C + D+ E)
			(A)	(B)	(C)	(D)	(E)	(F)
15	Supply & fixing of painted MS supports.	Kg	750					
16	Supply & fixing of PVC Drain pipe	m	100					
17	Supply, Installation, Testing and commissioning of Microprocessor based Control Panel (Wall mounted Type) with LCD display and Control Cable connection of Controller with ODUs and AHUs	Nos.	3					
a.	Supply Installation Testing and commissioning of Armoured XLPE Copper cable 1.5 Sq MM 6 Core from Control Panel to AHUs and Condensing units(ODUs)	RMT	385					
18	Electrical panel including power cables: Supply Installation Testing and commissioning of Main Control Panel Comprising of the followings:- One compartment with Incomer 315 A TPN SDFU with HRC Fuse of 315 A One compartment for Digital Multi Function Meter, Analog Voltmeter& Ammeter. Four Compartments with Outgoing feeder of 125 A TPN SDFU with HRC Fuse of 125 A , Analog Ammeter.	No	1					
a	Supply Installation Testing and commissioning of Armoured XLPE Aluminium cable 70 Sq MM 3.5 Core from Electrical panel to Control Panel	RMT	40					
b	Supply Installation Testing and commissioning of Armoured XLPE Aluminium cable 10 Sq MM 3 Core	RMT	285					
c	Supply Installation Testing and commissioning of Armoured XLPE Aluminium cable 4 Sq MM 3 Core	RMT	450					
19	Supply, fixing and commissioning of the following sizes of Hot dipped GI Ladder type cable trays with all required accessories like Couplers, Tees, Bends, Reducers, suitable support brackets, anchor fasteners, etc.							
a	600 mm wide x 75mm height x 2.0mm thick.	RMT	75					
b	300 mm wide x 75mm height x 2.0mm thick.	RMT	30					
Grand Total								
In words:								