

SL NO	Drawing/Document No	Title	DESIGNATION
1	EP-4-CS-053-001	SCHEME FOR INCOMER-A TO PMCC CONTROLLED FROM ECP & DDCMIS	DAET IC
2	EP-4-CS-053-002	SCHEME FOR INCOMER-B TO PMCC CONTROLLED FROM ECP & DDCMIS	DAET IC
3	EP-4-CS-053-003	SCHEME FOR BUSCOUPLER OF PMCC CONTROLLED FROM ECP & DDCMIS	DAE BC
4	EP-4-CS-053-004	SCHEME FOR INCOMER-A CONTROLLED FROM DDCMIS ONLY	DAE IC
5	EP-4-CS-053-005	SCHEME FOR INCOMER-B CONTROLLED FROM DDCMIS ONLY	DAE IC
6	EP-4-CS-053-006	SCHEME FOR BUSCOUPLER CONTROLLED FROM DDCMIS ONLY	DAE BC
7	EP-4-CS-053-007	SCHEME FOR MAIN DG INCOMER OF EMERGE CNY MCC CONTROLLED FROM ECP & DDCMIS	DAEG IC (M)
8	EP-4-CS-053-008	SCHEME FOR STANDBY DG INCOMER OF EMERGE CNY MCC CONTROLLED FROM ECP & DDCMIS	DAEG IC (S)
9	EP-4-CS-053-009	SCHEME FOR NORMAL INCOMER-A TO EMERGENCY MCC CONTROLLED FROM ECP & DDCMIS	DAE IC (DG)
10	EP-4-CS-053-010	SCHEME FOR NORMAL INCOMER-B TO EMERGENCY MCC CONTROLLED FROM ECP & DDCMIS	DAE IC (DG)
11	EP-4-CS-053-011	SCHEME FOR BUSCOUPLER OF EMERGENCY MCC CONTROLLED FROM ECP & DDCMIS	DG BC
12	EP-4-CS-053-012	SCHEME FOR TIE BREAKER TO EMERGENCY MCC	DAE TIE
13	EP-4-CS-053-013	SCHEME FOR OUTGOING ACB FEEDER FROM PMCC	DAE (OG)
14	EP-4-CS-053-014	SCHEME FOR UNIDIRECTIONAL MOTOR FEEDER ≥ 110 KW CONTROLLED FROM DDCMIS ONLY	DM
15	EP-4-CS-053-015	SCHEME FOR DCDB INCOMER FROM BATTERY CHARGER + DC BUSCOUPLER + BATTERY	CH+DB+DC
16	EP-4-CS-053-016	SCHEME FOR MCCB INCOMER	EM3 (IC)
17	EP-4-CS-053-017	SCHEME FOR MCCB BUSCOUPLER	EM3 (BC)
18	EP-4-CS-053-018	SCHEME FOR MCCB+CONTACTOR OPERATED INCOMER	EMC3 (IC)
19	EP-4-CS-053-019	SCHEME FOR MCCB OUTGOING	EM3
20	EP-4-CS-053-020	SCHEME FOR UNIDIRECTIONAL MOTOR FEEDER BELOW 30KW	DK2
21	EP-4-CS-053-021	SCHEME FOR UNIDIRECTIONAL MOTOR FEEDER ABOVE 30KW AND BELOW 110KW	DK21
22	EP-4-CS-053-022	SCHEME FOR BI-DIRECTIONAL MOTOR FEEDER (RDOL < 30 KW)	DN1
23	EP-4-CS-053-023	SCHEME FOR CRITICAL MOTOR FEEDER	DK2*
24	EP-4-CS-053-024	SCHEME FOR DC OUTGOING FEEDER	X
25	EP-4-CS-053-025	SCHEME FOR HEATER FEEDER	EA3
26	EP-4-CS-053-026	SCHEME FOR 240V AC SPACE HEATER SUPPLY	SH
27	EP-4-CS-053-027	SCHEME FOR BUS PT OF ACDB	VM
28	EP-4-CS-053-028	SCHEME FOR BUS PT FOR PMCC/ MCC	G1
29	EP-4-CS-053-029	SCHEME FOR BUS PT FOR DG	G2
30	EP-4-CS-053-030	SCHEME FOR 110V AC CONTROL SUPPLY	CS
31	EP-4-CS-053-031	SCHEME FOR DC BUS METERING/ RELAY MODULE	S
32	EP-4-CS-053-032	SCHEME FOR TEST CONTROL BUS	J2
33	EP-4-CS-053-033	SCHEME FOR 240V AC ESSENTIAL SUPPLY	J1
34	EP-4-CS-053-034	SCHEME FOR ESSENTIAL MOTOR FEEDER BELOW 30KW (REACCELERATION)	DK2E
35	EP-4-CS-053-035	SCHEME FOR ESSENTIAL MOTOR FEEDER ABOVE 30KW & BELOW 110KW (REACCELERATION)	DK21E
36	EP-4-CS-053-036	SCHEME FOR SPACE HEATER, PANEL ILLUMINATION AND POWER SOCKET	HTRT

FIRST ANGLE PROJECTION
ALL DIMENSIONS ARE IN MM.

TELANGANA STATE POWER GENERATION CORPORATION LTD
TELANGANA STATE
INDIA



CUSTOMER:

PROJECT:
4x270 MW BHADRADRI THERMAL POWER STATION
MANUGURU



DESEIN PRIVATE LTD

CUSTOMER CONSULTANT:

TABLE--1

S.NO	DESCRIPTION	BOARD NO.
1	UNIT PMCC	1DA,2DA,3DA & 4DA
2	STATION PMCC	0DA,00DB,00C & 0DD
3	EMERGENCY MCCs	1DG,2DG,3DG & 4DG

DRG. NO. EP-3-CS-053-001

COPYRIGHT AND CONFIDENTIAL
The information on the document is the property of BHARAT HEAVY ELECTRICALS LIMITED
It must not be used directly or indirectly in any way detrimental to the interest of the company

REV. NO.	DATE	DESCRIPTION	BY	APPD.	APPROVED	NAME	SIGN.	DATE	SCALE: NA	JOB NO. CP-14-053	DRG. NO. EP-3-CS-053-001	NO. OF SHEETS	NO. OF SHEET	REV.
1					CHECKED	TRINATH		16.12.15				10	01	00
2					DRAWN	JAGADISH		16.12.15						
3					DESIGNED	JAGADISH		16.12.15						
4														



BHARAT HEAVY ELECTRICALS LIMITED
ELECTROPROTECTIANS DIVISION BANGALORE
TITLE :
POWER & CONTROL SCHEME
INCOMER-A CONTROLLED FROM ECP & DDCMIS

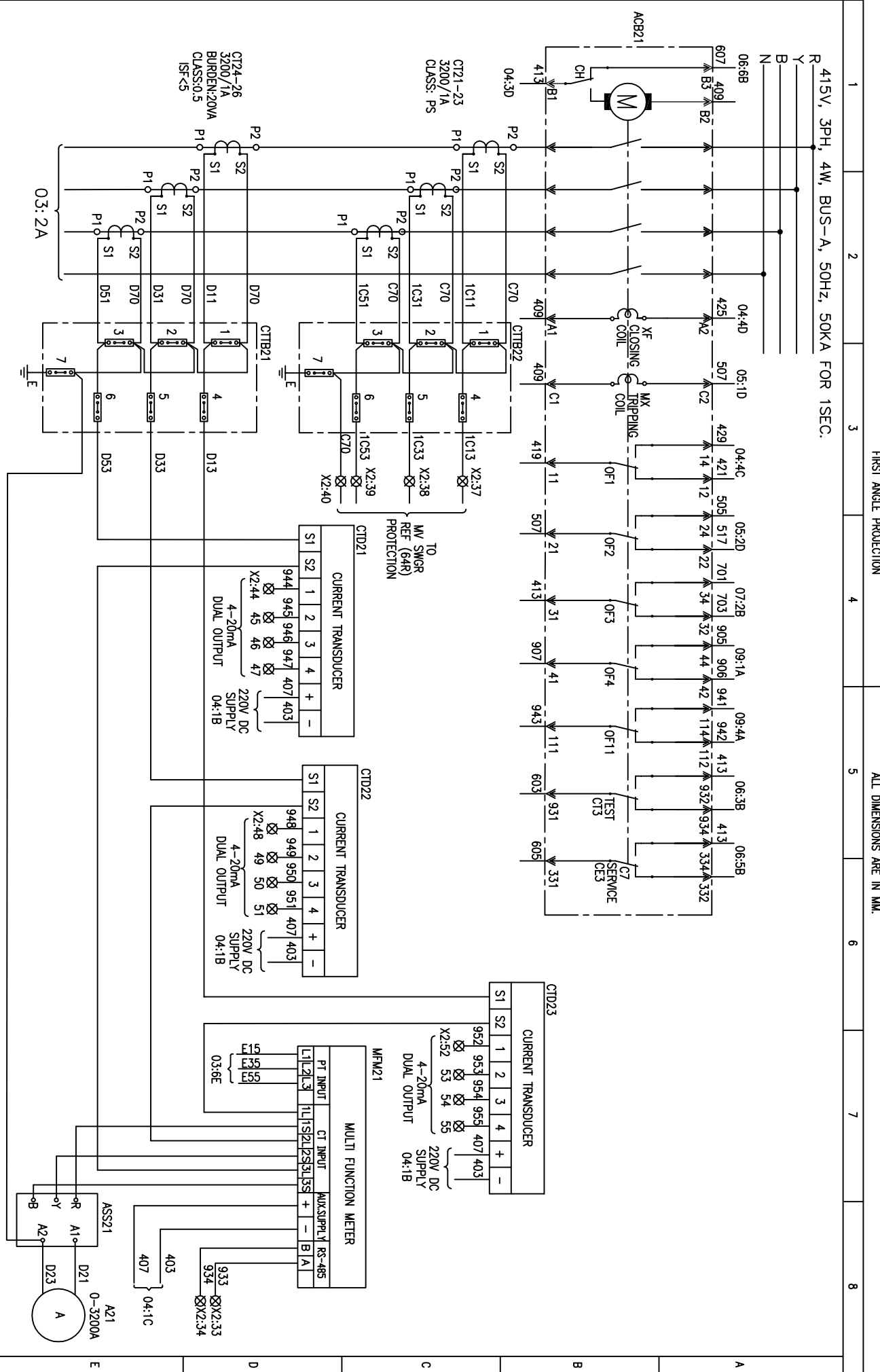

INVENTORY NO.	4	NAME	SIGN.	DATE	SCALE: NA	JOB NO. CP-14-053	DRG. NO. EP-3-CS-053-001
REV. NO.	1	DESIGNED	JAGADISH	16.12.15		TITLE: POWER & CONTROL SCHEME	
DATE	2	DRAWN		16.12.15		INCOMER-A CONTROLLED FROM ECP & DDCMS	
DESCRIPTION	3	CHECKED	TRINATH	16.12.15	NO. OF SHEETS	10	
BY	4	APPROVED	KSB	16.12.15	SHEET NO.	02	
					REV.	00	

DRG. NO. EP-3-CS-053-001

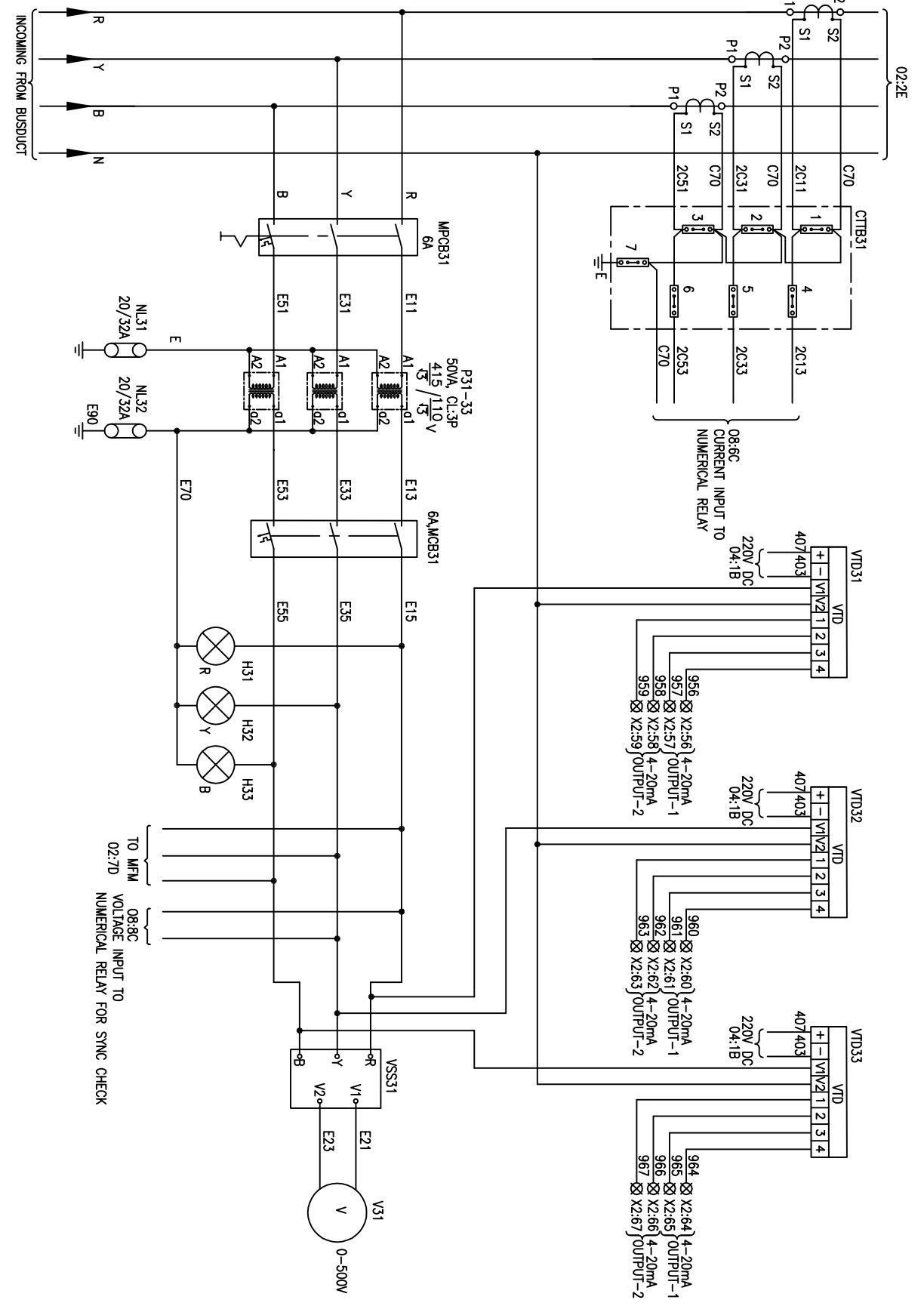

FIRST ANGLE PROJECTION

ALL DIMENSIONS ARE IN MM.

INVENTORY NO.	4	NAME	DATE	SCALE	JOB NO.	DRG. NO.	REV.
REV. NO.	1	SIGN.	16.12.15	MA	CP-14-053	EP-3-CS-053-001	00
DATE		BY	16.12.15				
DESCRIPTION		APPD.	16.12.15				
		APPROVED	16.12.15				
		KSB	16.12.15				
		TRINATH	16.12.15				
		CHECKED	16.12.15				
		DRAWN	16.12.15				
		DESIGNED	16.12.15				
		JAGADISH	16.12.15				

BHARAT HEAVY ELECTRICALS LIMITED
ELECTROPROTECTIANS DIVISION BANGALORE



TITLE :
POWER & CONTROL SCHEME
INCOMER-A CONTROLLED FROM ECP & DDCMS

NO. OF SHEETS: 10
SHEET NO.: 03

DRG. NO. EP-3-CS-053-001

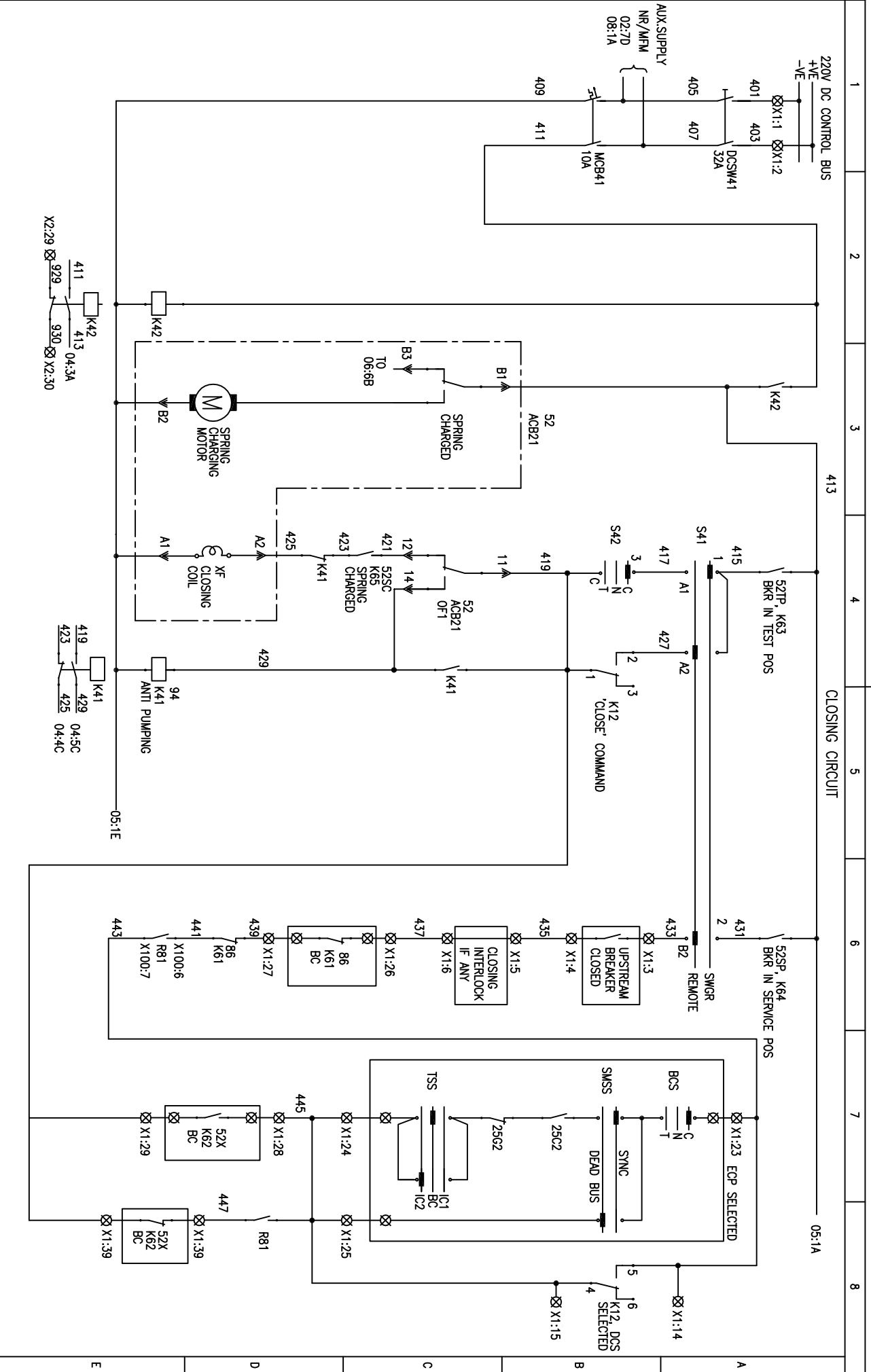

FIRST ANGLE PROJECTION

ALL DIMENSIONS ARE IN MM.

CLOSING CIRCUIT

INVENTORY NO.	4	NAME	TRINATH	DATE	16.12.15	SCALE	NA	JOB NO.	CP-14-053	DRG. NO.	EP-3-CS-053-001	
REV. NO.	1	CHECKED	TRINATH	CHECKED	16.12.15	BHARAT HEAVY ELECTRICALS LIMITED ELECTROPROTECTIANS DIVISION BANGALORE		TITLE	POWER & CONTROL SCHEME INCOMER-A CONTROLLED FROM ECP & DCOMIS			
DATE	2	DRAWN	JAGADISH	DESIGNED	16.12.15	E		NO. OF SHEETS	10			
DESCRIPTION	3	BY	KSB	APPD.	16.12.15	D		SHEET NO.	04			
	4	APPROVED		APPROVED		C		REV.	00			

DRG. NO. EP-3-CS-053-001

FORM 66-271 A3

FIRST ANGLE PROJECTION

ALL DIMENSIONS ARE IN MM.

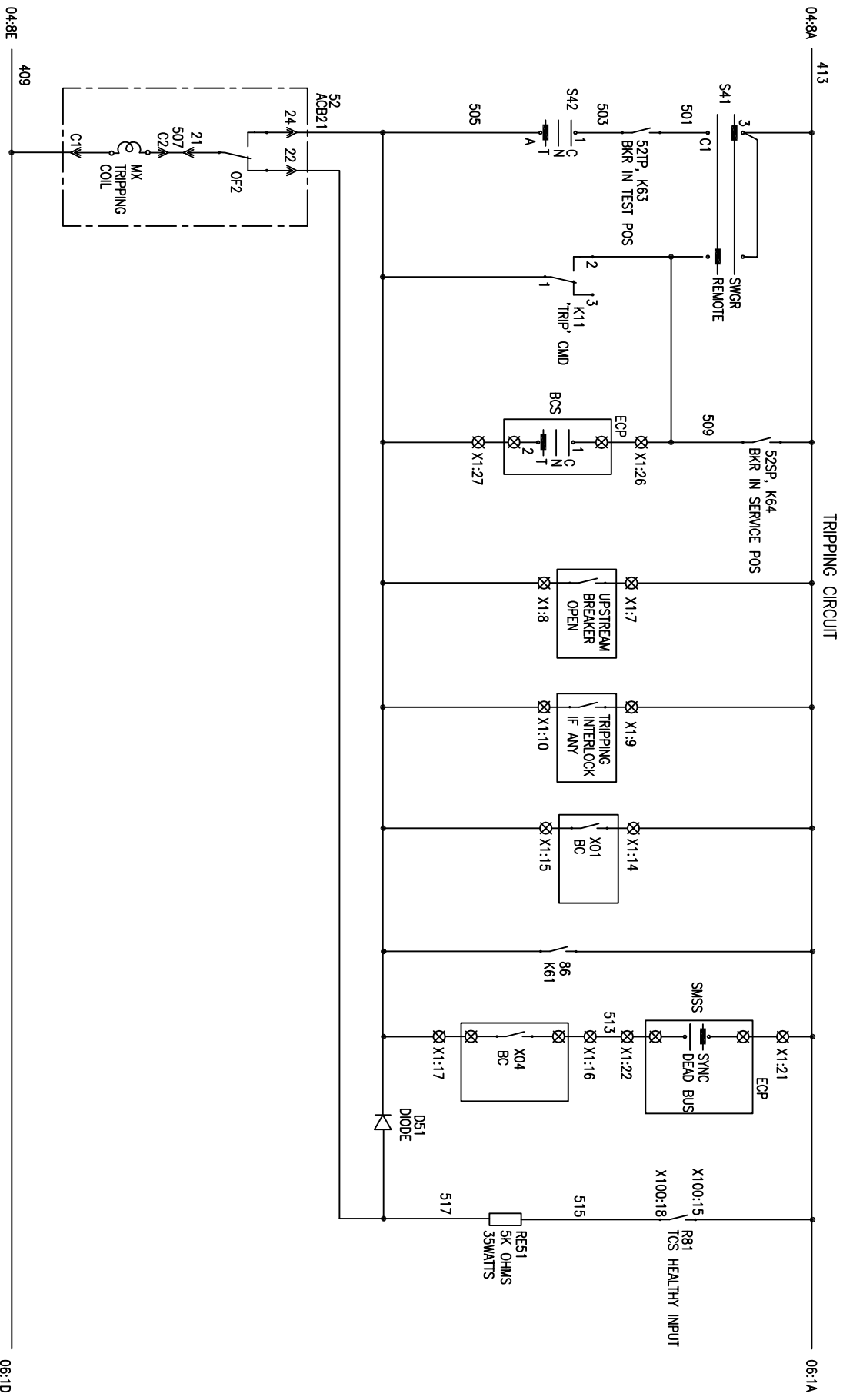

REV. NO.	DATE	DESCRIPTION	BY	APPD.	APPROVED	NAME	SIGN.	DATE	SCALE	JOB NO.	DRG. NO.	NO. OF SHEETS	SHEET NO.	REV.
1					CHECKED	TRINATH		16.12.15	NA	CP-14-053	EP-3-CS-053-001	10	05	00
2					DRAWN	JAGADISH		16.12.15						
3					DESIGNED	JAGADISH		16.12.15						
4														

BHARAT HEAVY ELECTRICALS LIMITED
ELECTROPOWERELANS DIVISION BANGALORE



TITLE :
POWER & CONTROL SCHEME
INCOMER-A CONTROLLED FROM ECP & DCOMIS



NO. OF SHEETS: 10
SHEET NO.: 05
REV.: 00

DRG. NO. EP-3-CS-053-001

FIRST ANGLE PROJECTION

ALL DIMENSIONS ARE IN MM.

RELAY CIRCUIT

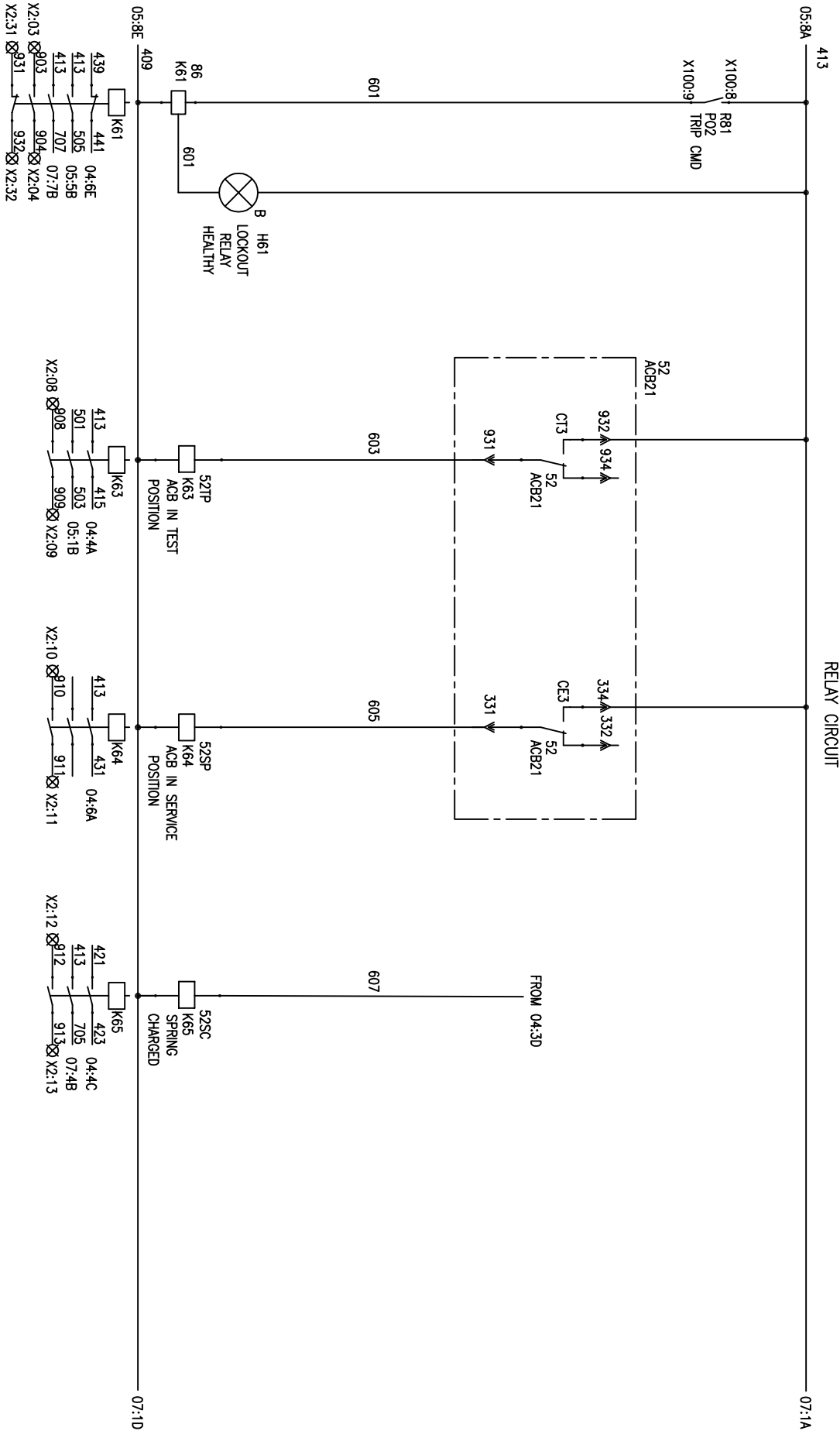

REV. NO.	DATE	DESCRIPTION	BY	APPD.	APPROVED	KSB	SCALE: NA	JOB NO. CP-14-053	DRG. NO. EP-3-CS-053-001	NO. OF SHEETS	SHEET NO.	REV.
1					CHECKED	TRINATH				10	06	00
2					DRAWN							
3					DESIGNED	JAGADISH						
4												

BHARAT HEAVY ELECTRICALS LIMITED
ELECTROPOWERCELLS DIVISION BANGALORE



TITLE: POWER & CONTROL SCHEME
INCUMER-A CONTROLLED FROM ECP & DDCMIS

DRG. NO. EP-3-CS-053-001

FIRST ANGLE PROJECTION

ALL DIMENSIONS ARE IN MM.

INDICATION CIRCUIT

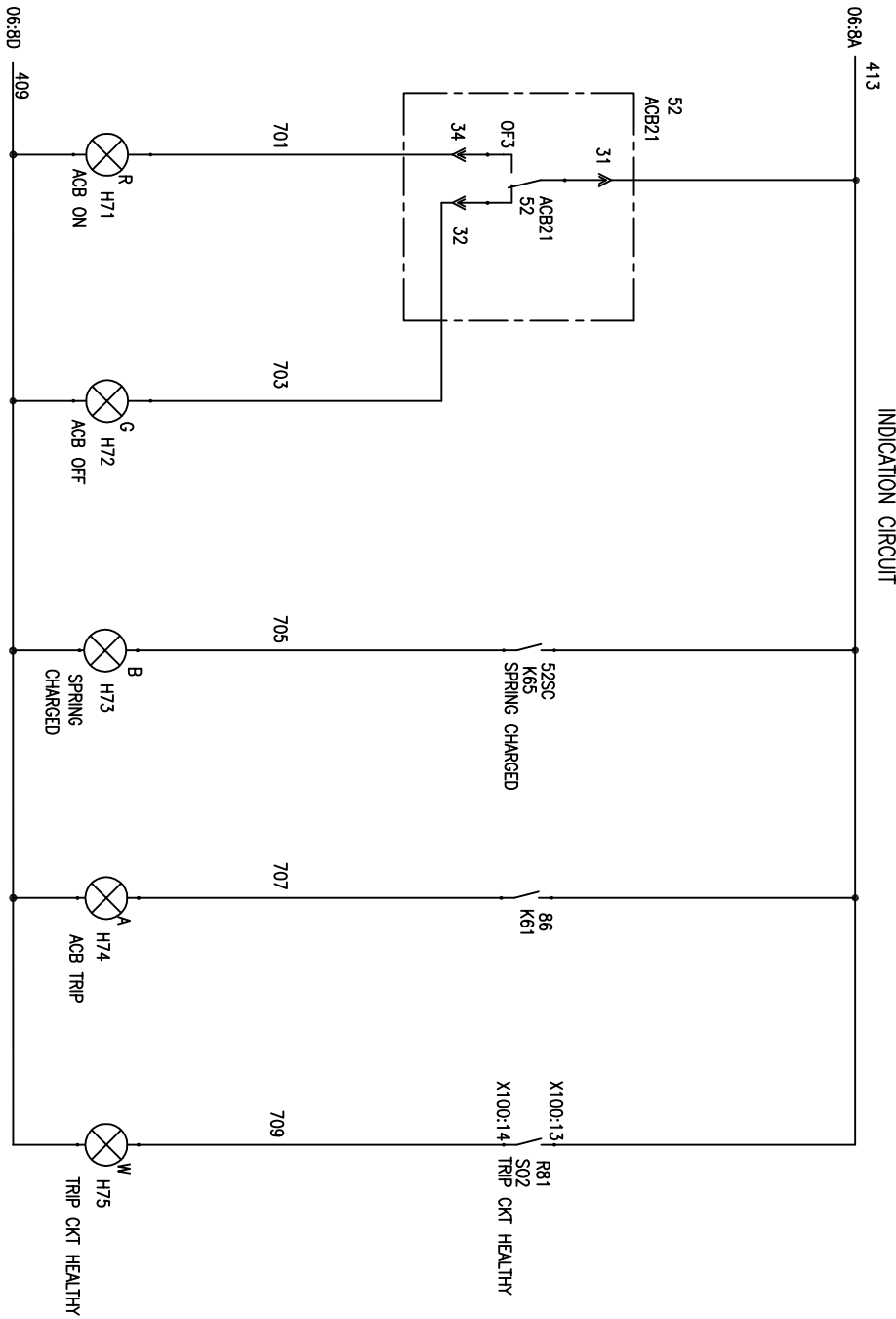

REV. NO.	DATE	DESCRIPTION	BY	APPD.	APPROVED	KSB	SCALE: NA	JOB NO. CP-14-053	DRG. NO. EP-3-CS-053-001	NO. OF SHEETS	SHEET NO.	REV.
1					CHECKED	TRINATH				10	07	00
2					DRAWN							
3					DESIGNED	JAGADISH						
4												

BHARAT HEAVY ELECTRICALS LIMITED
ELECTROPOWERCELLS DIVISION BANGALORE

POWER & CONTROL SCHEME
INCOMER-A CONTROLLED FROM ECP & DDCMS



R81, NUMERICAL RELAY TYPE: REF615

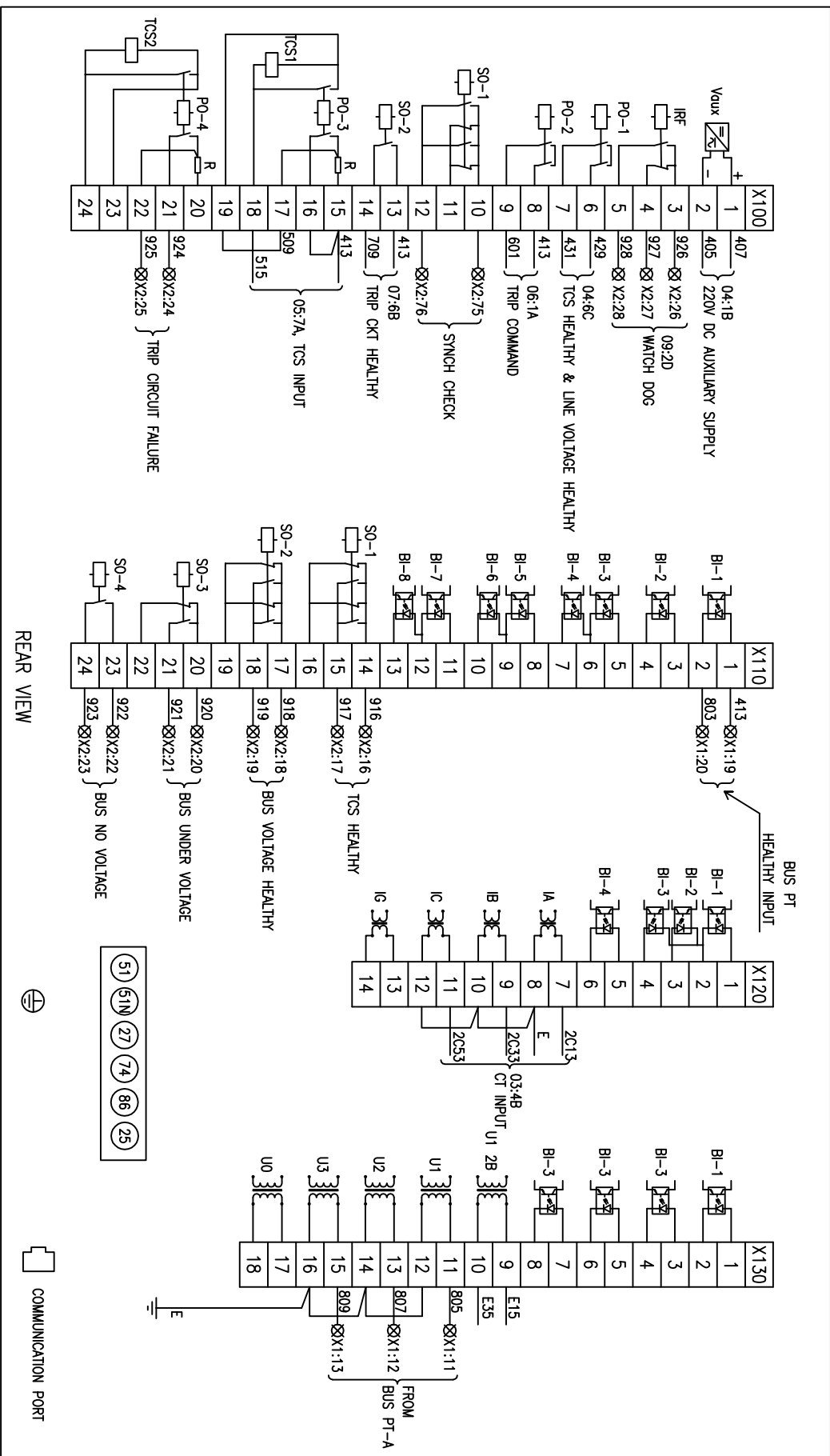

REAR VIEW



COMMUNICATION PORT

COPYRIGHT AND CONFIDENTIAL
The information on the document is the property of BHARAT HEAVY ELECTRICALS LIMITED
It must not be used directly or indirectly in any way detrimental to the interest of the company

DRG. NO. EP-3-CS-053-001

INVENTORY NO.	4	3	2	1
REV. NO.				
DATE				
DESCRIPTION				
BY				
APPD.				
APPROVED				
NAME				
SIGN.				
DATE				
DESIGNED				
DRAWN				
CHECKED				
TRINATH				
KSB				
SCALE	NA			
JOB NO.	CP-14-053			
DRG. NO.	EP-3-CS-053-001			
TITLE	BHARAT HEAVY ELECTRICALS LIMITED ELECTROPROTECTIANS DIVISION BANGALORE			
	POWER & CONTROL SCHEME INCOMER-A CONTROLLED FROM ECP & DDGMS			
NO. OF SHEETS	10			
SHEET NO.	08			
REV.	00			

The information on the document is the property of BHARAT HEAVY ELECTRICALS LIMITED
It must not be used directly or indirectly in any way detrimental to the interest of the company

DRG. NO. EP-3-CS-053-001

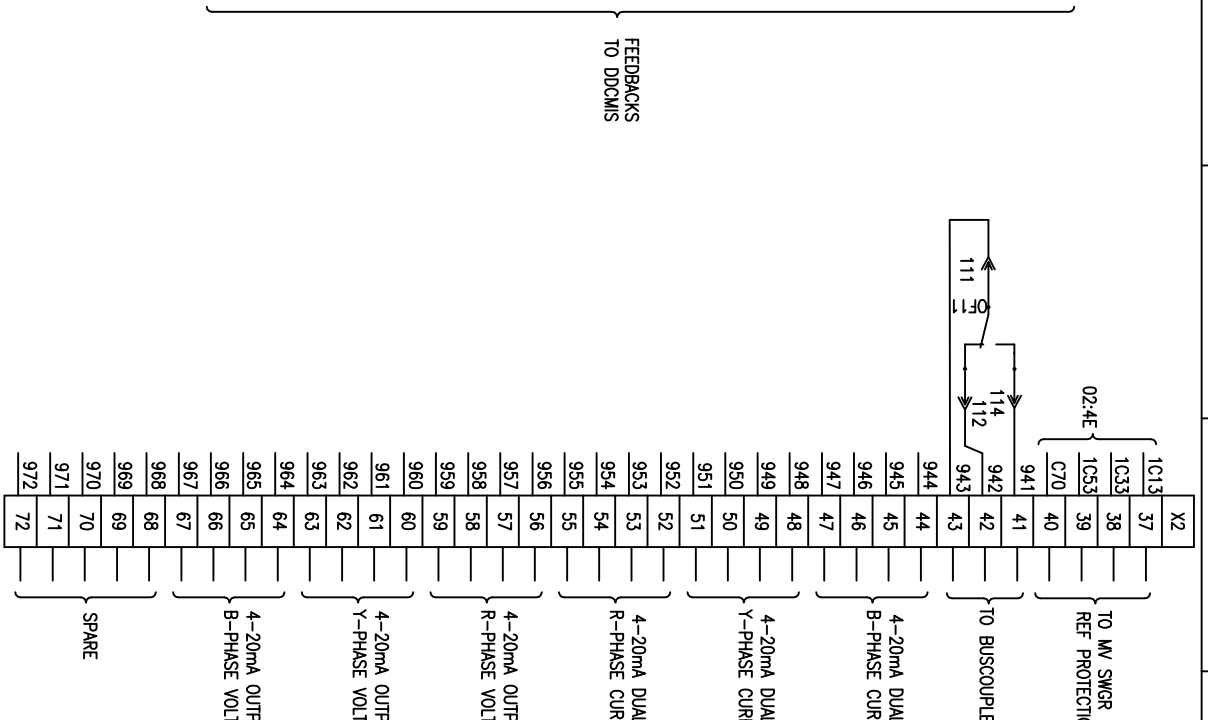
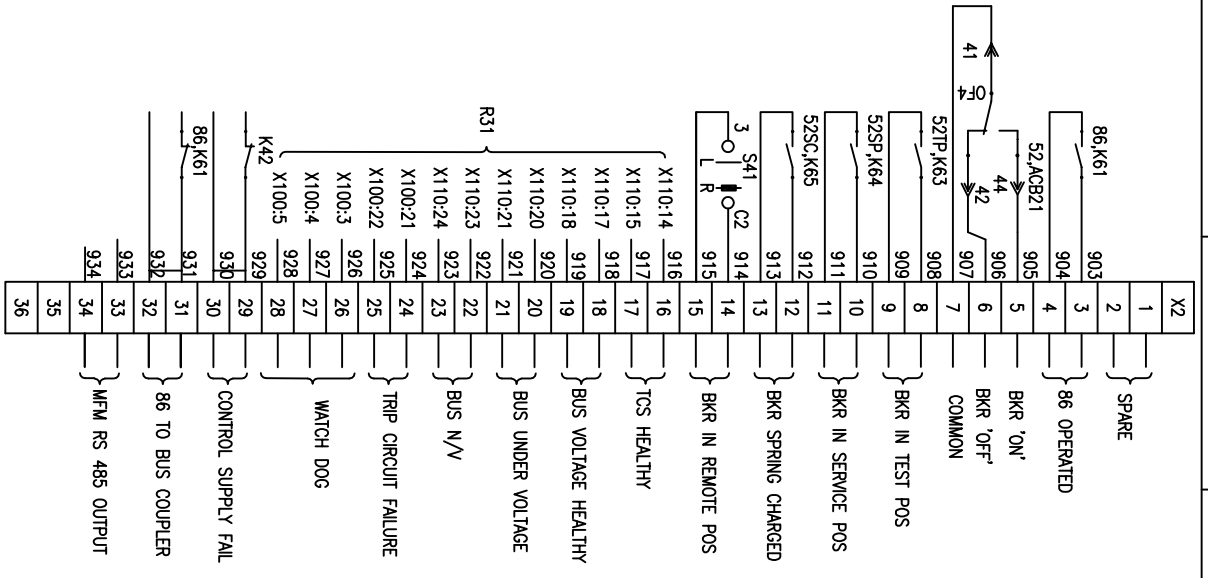

1 FIRST ANGLE PROJECTION 2 3 4 5 ALL DIMENSIONS ARE IN MM 6 7 8

REV. NO.	DATE	DESCRIPTION	BY	APPD.	APPROVED	KSB	NAME	SIGN.	DATE	SCALE	JOB NO.	DRG. NO.	NO. OF SHEETS	SHEET NO.	REV.
1					CHECKED		TRINATH		16.12.15	NA	CP-14-053	EP-3-CS-053-001	10	09	00
2					DRAWN										
3					DESIGNED		JAGADISH		16.12.15						
4															

NO. OF SHEETS	SHEET NO.	REV.
10	09	00

BHARAT HEAVY ELECTRICALS LIMITED
ELECTROPOWERCELLS DIVISION BANGALORE

POWER & CONTROL SCHEME
INCOMER-A CONTROLLED FROM ECP & DDCMIS



The information on the document is the property of BHARAT HEAVY ELECTRICALS LIMITED
It must not be used directly or indirectly in any way detrimental to the interest of the company

DRG. NO. EP-3-CS-053-001

FIRST ANGLE PROJECTION
ALL DIMENSIONS ARE IN MM

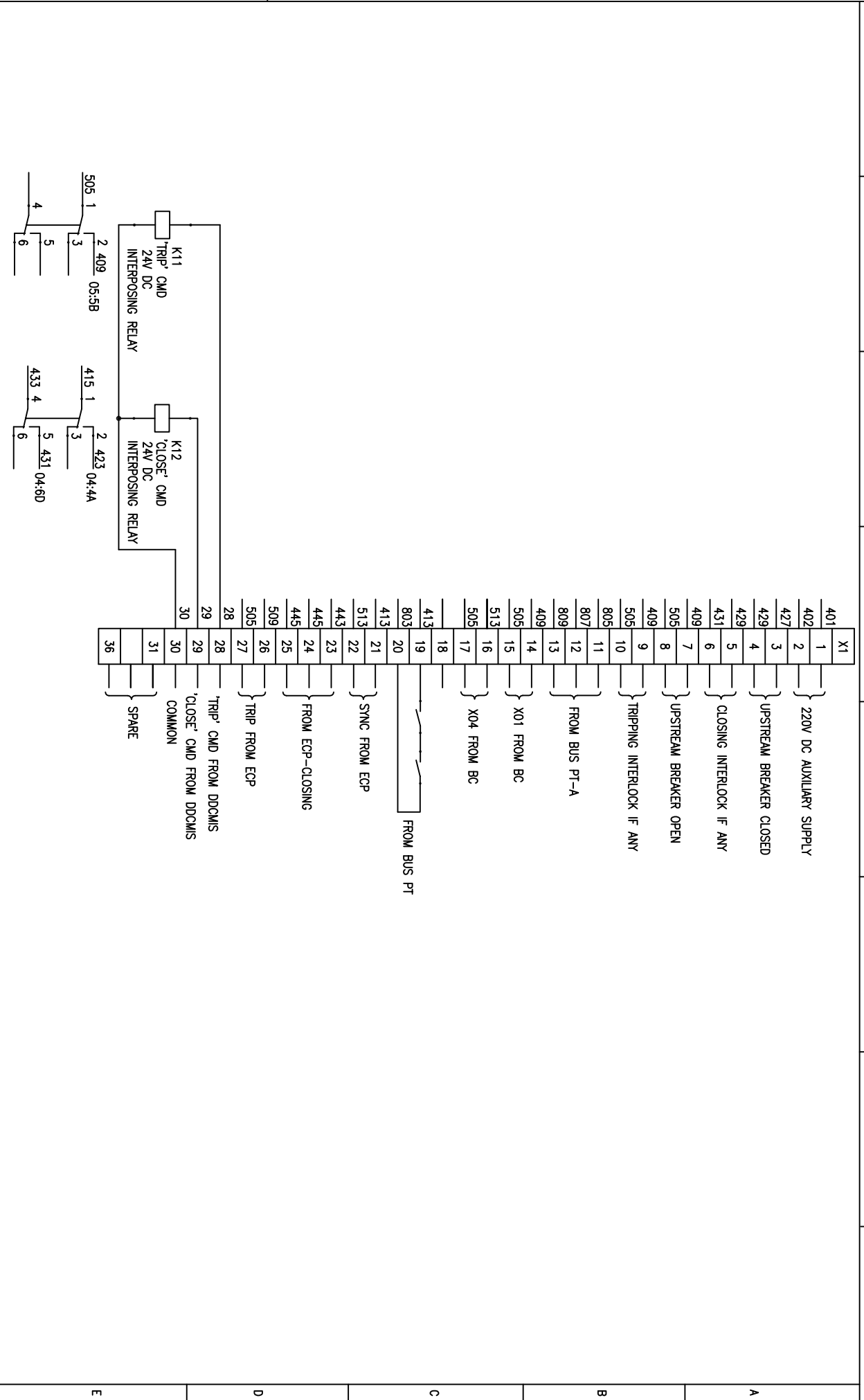

REV. NO.	DATE	DESCRIPTION	BY	APPD.	APPROVED	KSB	NAME	SIGN.	DATE	SCALE	JOB NO.	DRG. NO.	NO. OF SHEETS	SHEET NO.	REV.
1					CHECKED		TRINATH		16.12.15	NA	CP-14-053	EP-3-CS-053-001	10	10	00
2					DRAWN		JAGADISH		16.12.15						
3					DESIGNED		JAGADISH		16.12.15						
4															

BHARAT HEAVY ELECTRICALS LIMITED
ELECTROPROTECTIVES DIVISION BANGALORE

TITLE :
POWER & CONTROL SCHEME
INCOMER-A CONTROLLED FROM ECP & DDCMIS



NO. OF SHEETS: 10
SHEET NO.: 10

FIRST ANGLE PROJECTION
ALL DIMENSIONS ARE IN MM.

TELANGANA STATE POWER GENERATION CORPORATION LTD
TELANGANA STATE
INDIA



CUSTOMER:

PROJECT:
4x270 MW BHADRADRI THERMAL POWER STATION
MANUGURU

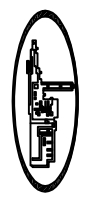

DESEIN PRIVATE LTD

CUSTOMER CONSULTANT:

TABLE--1

S.NO	DESCRIPTION	BOARD NO.
1	UNIT PMCC	1DA,2DA,3DA & 4DA
2	STATION PMCC	0DA,00DB,00C & 00D
3	EMERGENCY MCCs	1DG,2DG,3DG & 4DG

DRG. NO. EP-3-CS-053-002

COPYRIGHT AND CONFIDENTIAL
The information on the document is the property of BHARAT HEAVY ELECTRICALS LIMITED
It must not be used directly or indirectly in any way detrimental to the interest of the company

INVENTORY NO.	REV. NO.	DATE	DESCRIPTION	BY	APPD.	APPROVED	NAME	SIGN.	DATE	SCALE: NA	JOB NO. CP-14-053	DRG. NO. EP-3-CS-053-002	NO. OF SHEETS	REV.
4													10	00
3						DESIGNED	JAGADISH		16.12.15				01	
2						DRAWN								
1						CHECKED	TRINATH		16.12.15					



BHARAT HEAVY ELECTRICALS LIMITED
ELECTROPOWERCELLS DIVISION BANGALORE
TITLE :
POWER & CONTROL SCHEME
INCOMER-B CONTROLLED FROM ECP & DDCMIS

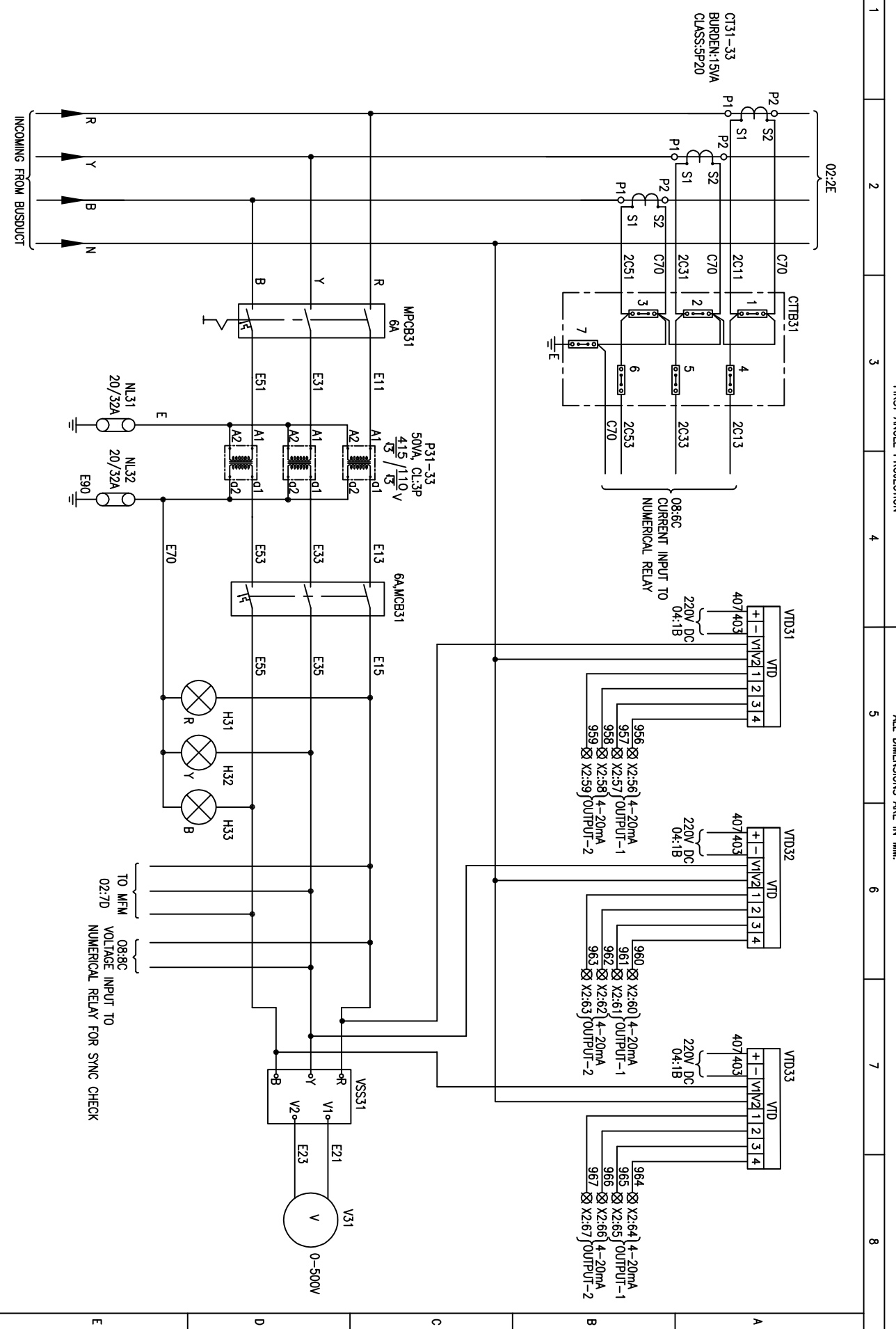

INVENTORY NO.	4	NAME	DATE	SCALE	JOB NO.	DRG. NO.
REV. NO.	1	SIGN.	16.12.15	NA	CP-14-053	EP-3-CS-053-002
DATE		DATE	16.12.15			
DESCRIPTION		DESIGNED	16.12.15			
		DRAWN	16.12.15			
		CHECKED	16.12.15			
		BY	16.12.15			
		APPD.				
		APPROVED				
		KSB				
		BHARAT HEAVY ELECTRICALS LIMITED				
		ELECTROPROTECTANS DIVISION BANGALORE				
		TITLE :				
		POWER & CONTROL SCHEME				
		INCOMER-B CONTROLLED FROM ECP & DDCMS				
		NO. OF SHEETS				
		10				
		SHEET NO.				
		03				
		REV.				
		00				

DRG. NO. EP-3-CS-053-001

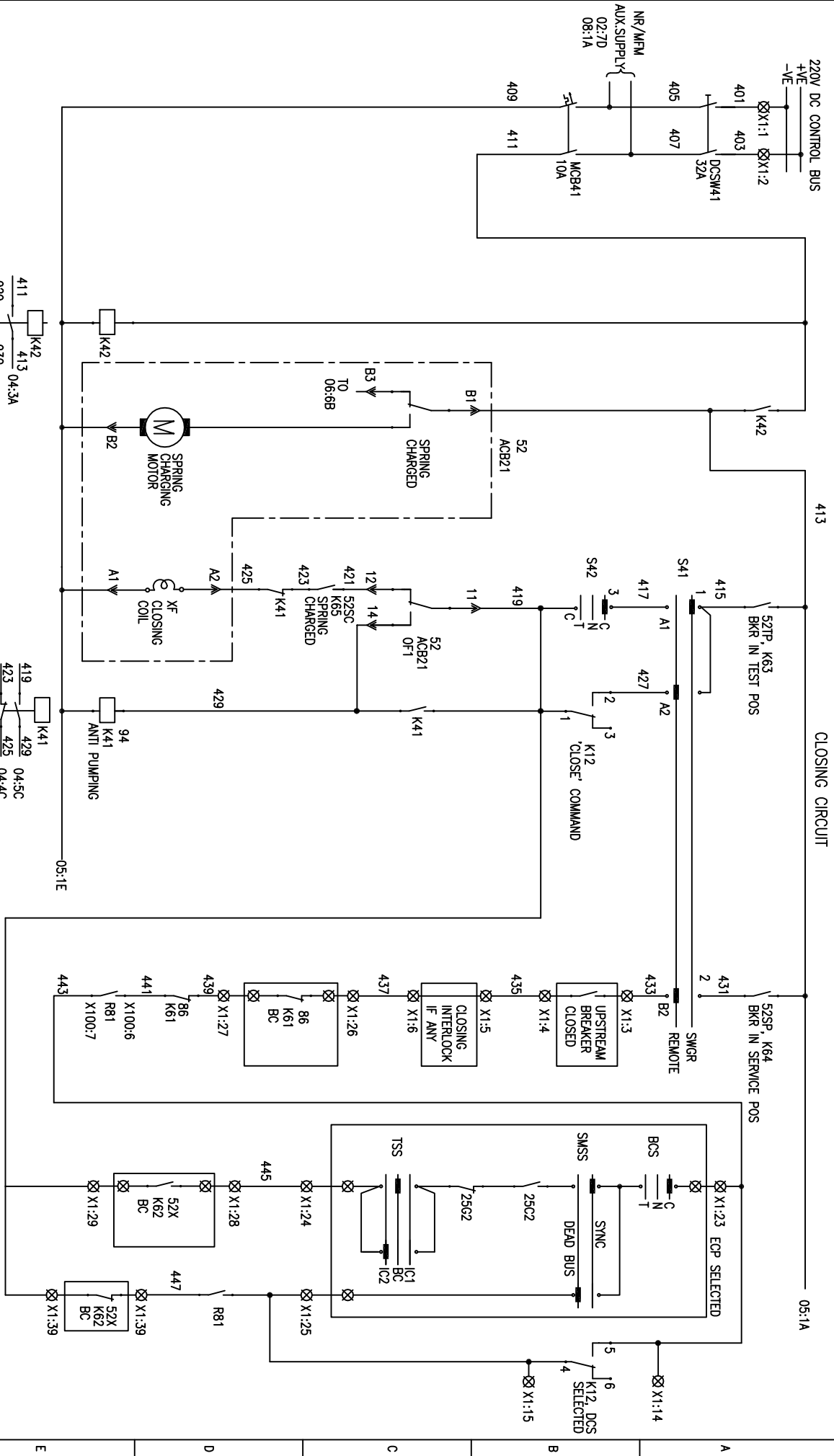

FIRST ANGLE PROJECTION
 ALL DIMENSIONS ARE IN MM

INVENTORY NO.	4	3	2	1
REV. NO.	1	2	3	4
DATE				
DESCRIPTION				
BY				
APPD.				
APPROVED				
KSB				
NAME	JAGADISH			
SIGN.				
DATE	16.12.15			
SCALE	NA			
TITLE	BHARAT HEAVY ELECTRICALS LIMITED ELECTROPOWERCELLS DIVISION BANGALORE			
JOB NO.	CP-14-053			
DRG. NO.	EP-3-CS-053-002			
NO. OF SHEETS	10			
SHEET NO.	04			
REV.	00			

DRG. NO. EP-3-CS-053-001

FORM 66-271 A3

FIRST ANGLE PROJECTION

ALL DIMENSIONS ARE IN MM.

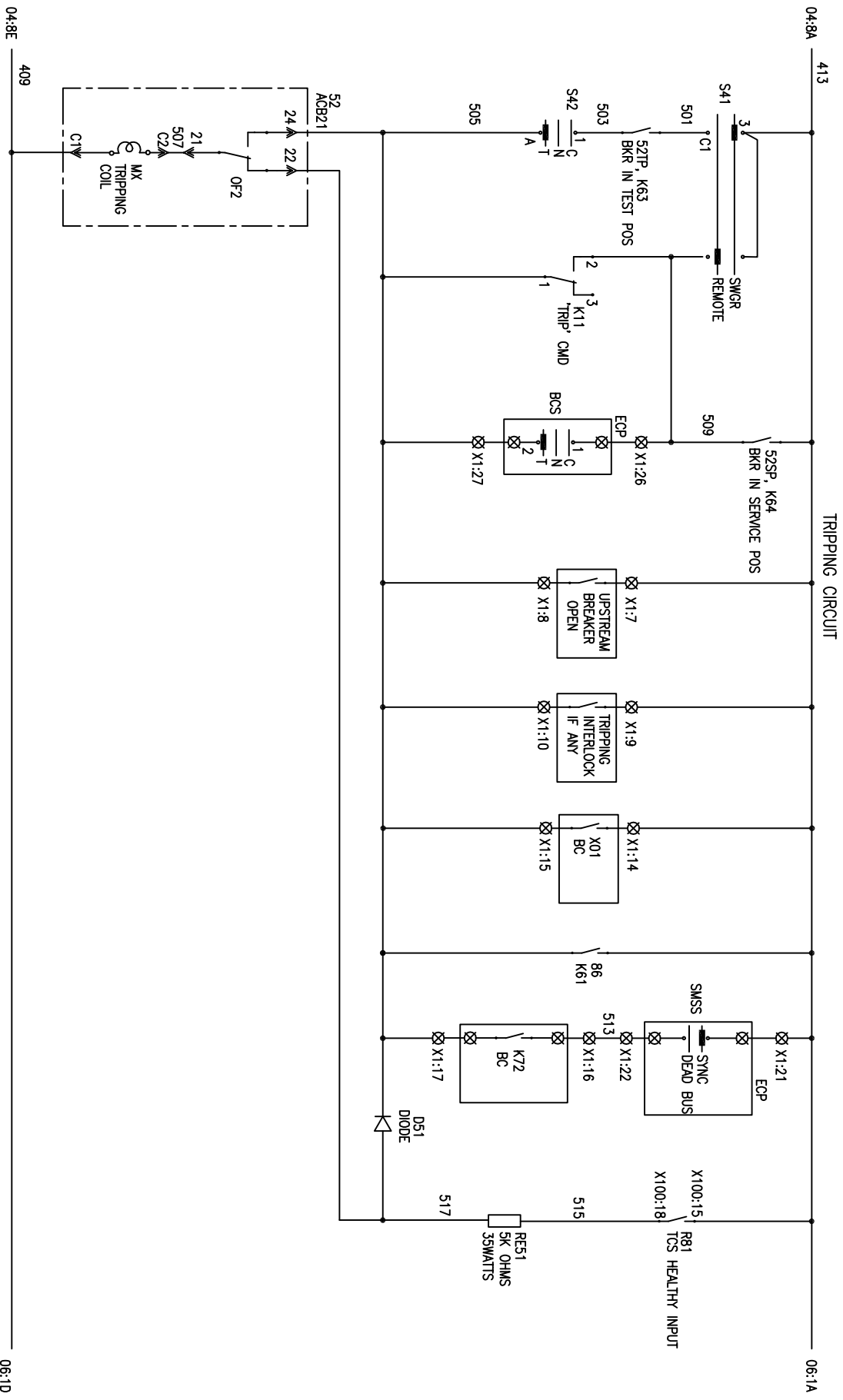

REV. NO.	DATE	DESCRIPTION	BY	APPD.	APPROVED	NAME	SIGN.	DATE	SCALE	JOB NO.	DRG. NO.	NO. OF SHEETS	SHEET NO.	REV.
1					CHECKED	TRINATH		16.12.15	NA	CP-14-053	EP-3-CS-053-002	10	05	
2					DRAWN			16.12.15						
3					DESIGNED	JAGADISH		16.12.15						
4														

BHARAT HEAVY ELECTRICALS LIMITED
ELECTROFORCELANS DIVISION BANGALORE



TITLE :
POWER & CONTROL SCHEME
INCOMER-B CONTROLLED FROM ECP & DCOMIS

NO. OF SHEETS	10
SHEET NO.	05
REV.	00

DRG. NO. EP-3-CS-053-002

FORM 66-271 A3

FIRST ANGLE PROJECTION
ALL DIMENSIONS ARE IN MM

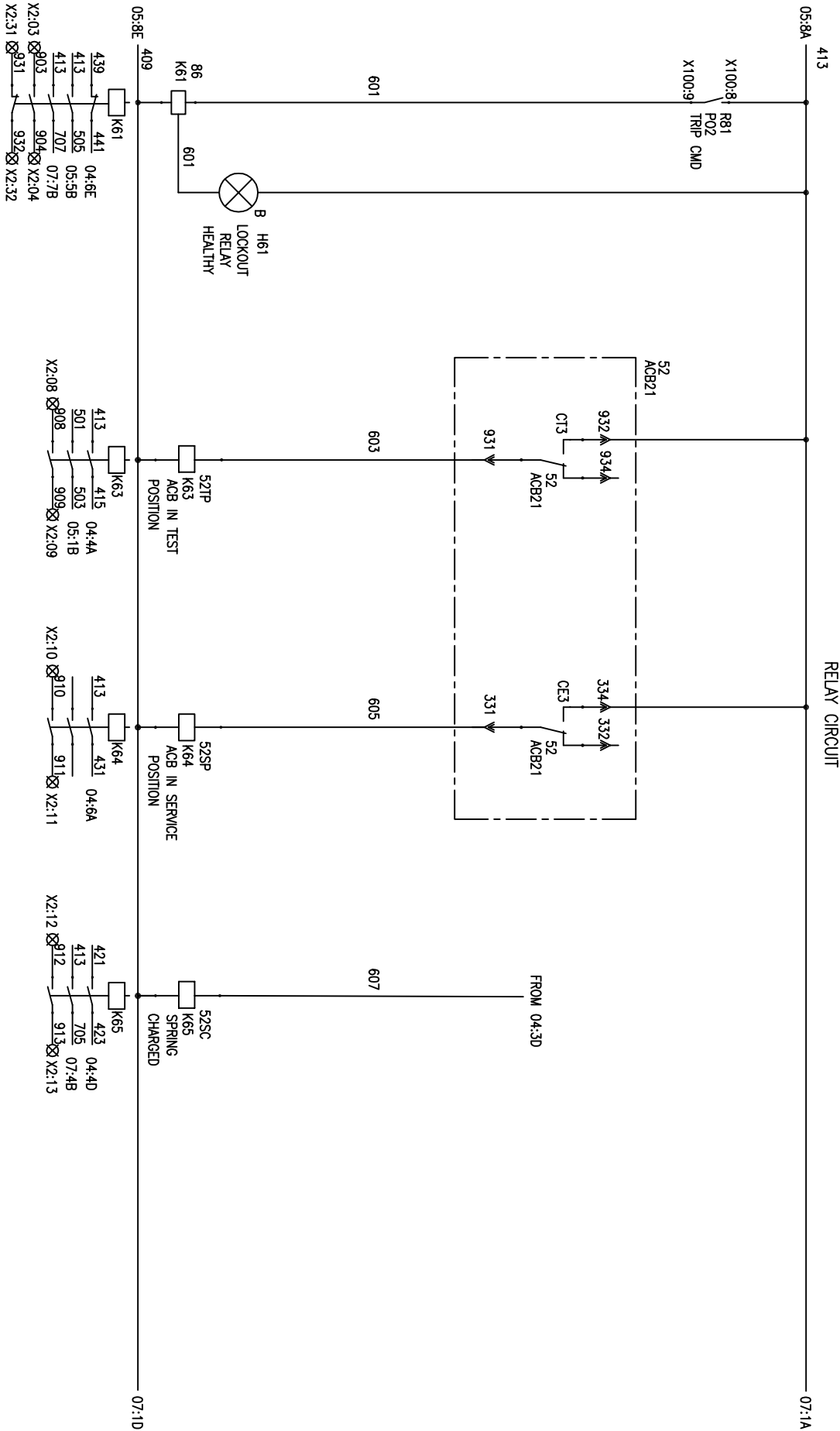

REV. NO.	DATE	DESCRIPTION	BY	APPD.	APPROVED	KSB	SCALE: NA	JOB NO. CP-14-053	DRG. NO. EP-3-CS-053-002	REV. NO.
1					CHECKED	TRINATH	16.12.15			06
2					DRAWN		16.12.15			10
3					DESIGNED	JAGADISH	16.12.15			
4										

BHARAT HEAVY ELECTRICALS LIMITED
ELECTROPOWERELANS DIVISION BANGALORE

TITLE :
POWER & CONTROL SCHEME
INCOMER-B CONTROLLED FROM ECP & DDCMIS



NO. OF SHEETS: 10
SHEET NO.: 06
REV. NO.: 00

DRG. NO. EP-3-CS-053-002

INVENTORY NO.

REV. NO.	DATE	DESCRIPTION	BY	APPD.	APPROVED	KSB	SCALE: NA	JOB NO. CP-14-053	DRG. NO. EP-3-CS-053-002	NO. OF SHEETS	NO. OF SHEETS	REV.
1					CHECKED	TRINATH	16.12.15			10	07	00
2					DRAWN							
3					DESIGNED	JAGADISH	16.12.15					
4												

FIRST ANGLE PROJECTION

ALL DIMENSIONS ARE IN MM.

INDICATION CIRCUIT

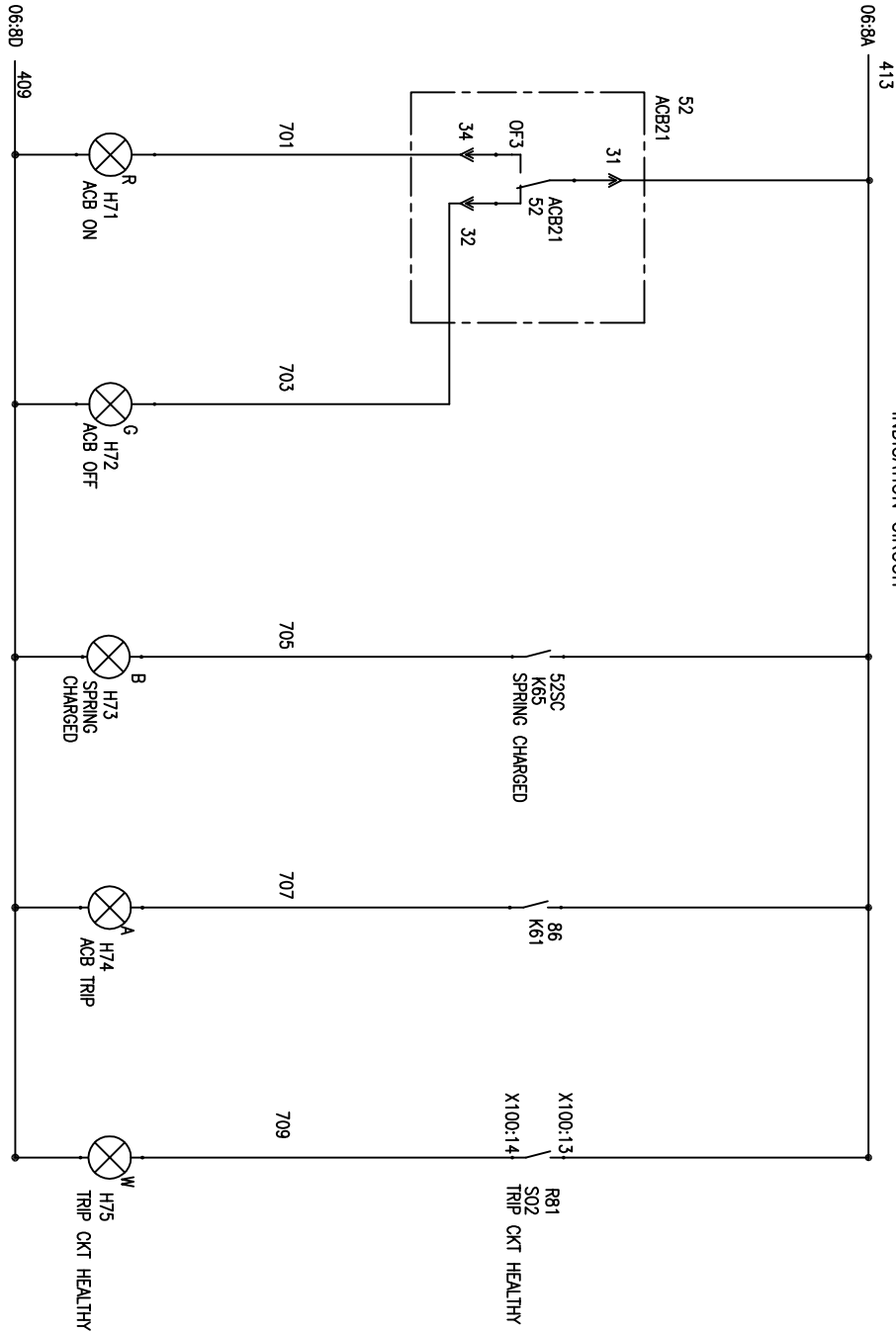

BHARAT HEAVY ELECTRICALS LIMITED
ELECTROPOWERCELLS DIVISION BANGALORE

POWER & CONTROL SCHEME
INCOMER-B CONTROLLED FROM ECP & DDCMIS



DRG. NO. EP-3-CS-053-002

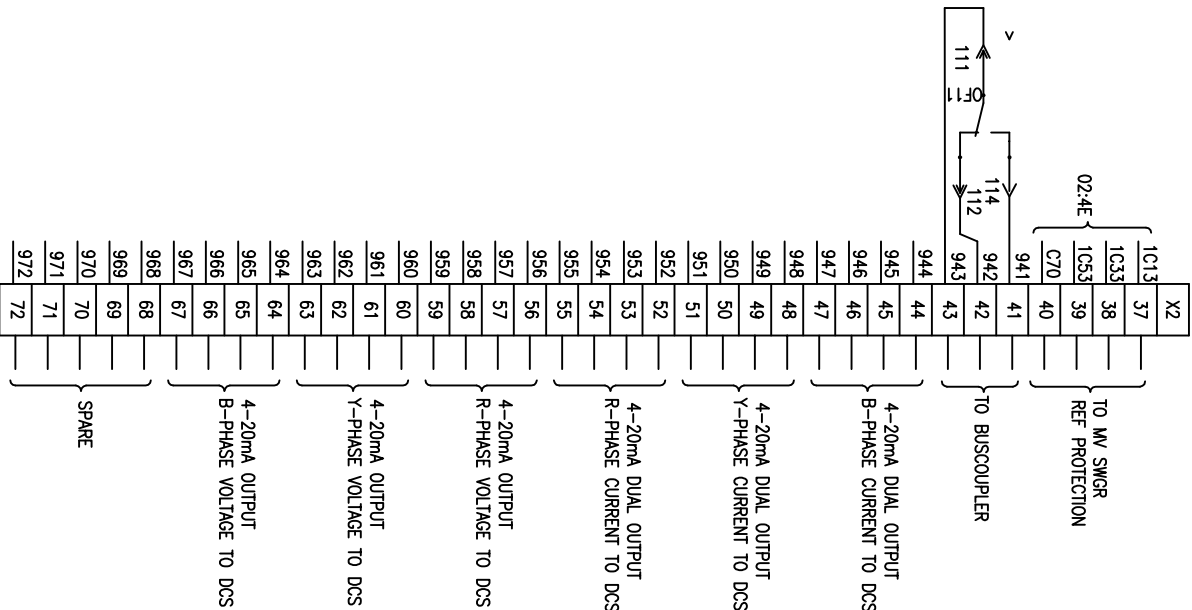
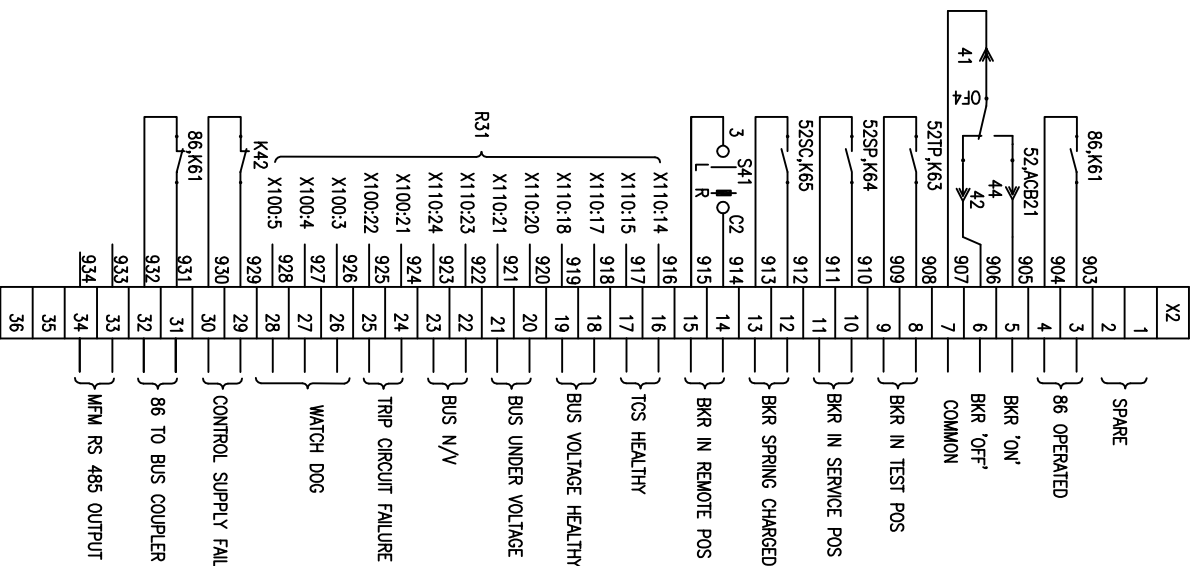

FIRST ANGLE PROJECTION

ALL DIMENSIONS ARE IN MM

INVENTORY NO.				BY				NAME				DATE				BHARAT HEAVY ELECTRICALS LIMITED				NO. OF SHEETS	
1	2	3	4	APPD.	APPROVED	KSB	16.12.15	SCALE: NA	JOB NO. CP-14-053	DRG. NO. EP-3-CS-053-002	ELECTROPROTECTANS DIVISION BANGALORE				POWER & CONTROL SCHEME				10		
REV. NO.	DATE	DESCRIPTION									TRINATH				INCOMER-B CONTROLLED FROM ECP & DDCMS				09		
1					CHECKED		16.12.15				SIGN.								REV. NO.		
2					DRAWN														00		
3					DESIGNED	JAGADISH	16.12.15														
4																					

DRG. NO. EP-3-CS-053-002

INVENTORY NO.

REV. NO.	DATE	DESCRIPTION	BY	APPD.	APPROVED	KSB	SCALE: NA	JOB NO. CP-14-053	DRG. NO. EP-3-CS-053-002	NO. OF SHEETS	NO. OF SHEETS	REV.
1					CHECKED	TRINATH	16.12.15			10	10	00
2					DRAWN							
3					DESIGNED	JAGADISH	16.12.15					
4												

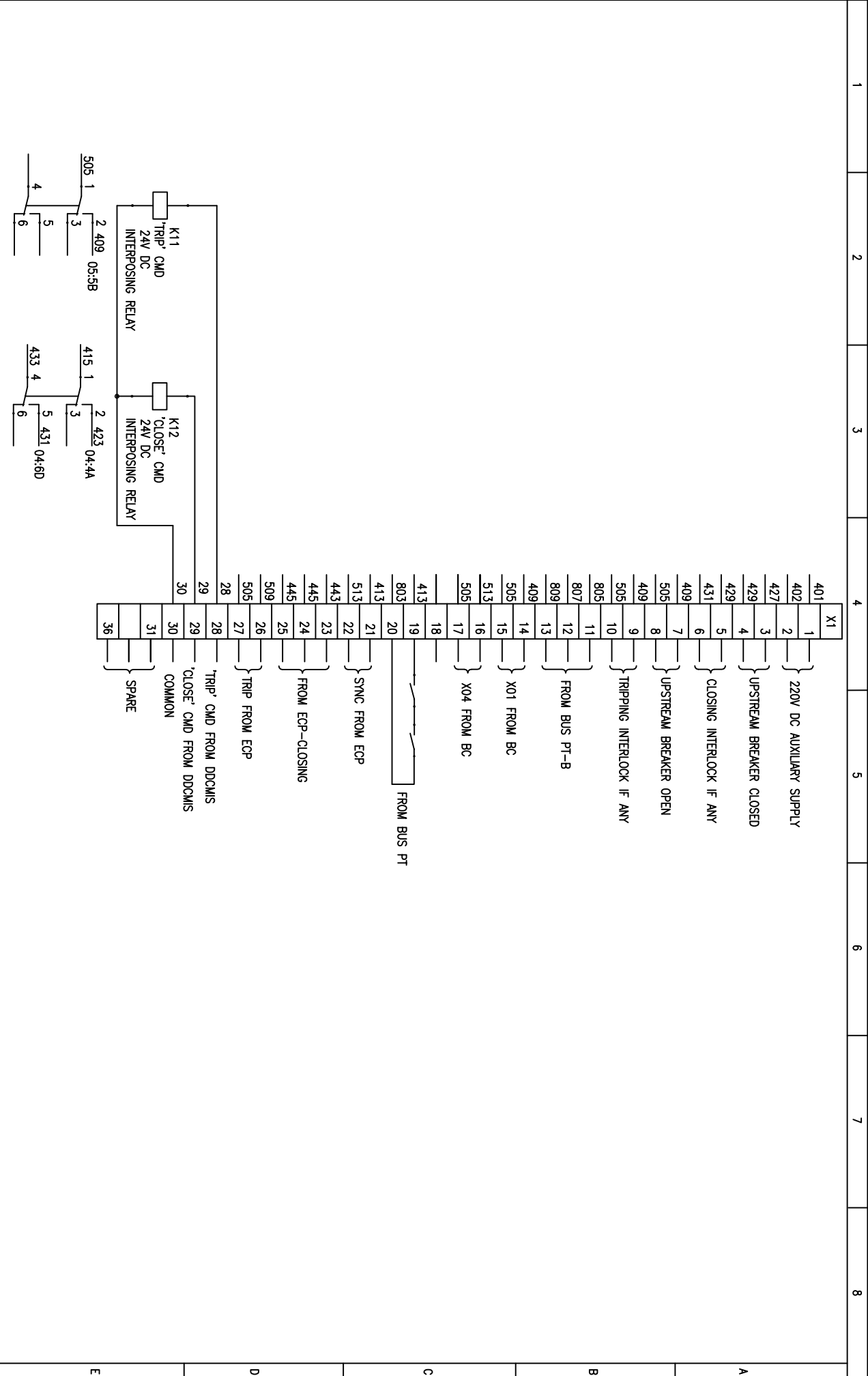

FIRST ANGLE PROJECTION ALL DIMENSIONS ARE IN MM

BHARAT HEAVY ELECTRICALS LIMITED
ELECTROPOWERCELLS DIVISION BANGALORE

POWER & CONTROL SCHEME
INCOMER-B CONTROLLED FROM ECP & DDCMIS



NO. OF SHEETS: 10
SHEET NO.: 10

FIRST ANGLE PROJECTION

ALL DIMENSIONS ARE IN MM.

1

2

3

4

5

6

7

8

CUSTOMER:



TELANGANA STATE POWER GENERATION CORPORATION LTD
TELANGANA STATE
INDIA

PROJECT:
4x270 MW BHADRADRI THERMAL POWER STATION
MANUGURU

CUSTOMER CONSULTANT:



DESEIN PRIVATE LTD

COPYRIGHT AND CONFIDENTIAL

The information on the document is the property of BHARAT HEAVY ELECTRICALS LIMITED
It must not be used directly or indirectly in any way detrimental to the interest of the company

DRG. NO. **EP-3-CS-053-003**

TABLE--1		
S.NO	DESCRIPTION	BOARD NO.
1	UNIT PMCC	1DA,2DA,3DA & 4DA
2	STATION PMCC	0DA,00DB,00C & 0DD
3	EMERGENCY MCCs	1DG,2DG,3DG & 4DG

REV. NO.	DATE	DESCRIPTION	BY	APPD.	APPROVED	NAME	SIGN.	DATE	SCALE: NA	JOB NO. CP-14-053	DRG. NO. EP-3-CS-053-003	NO. OF SHEETS	SHEET NO.	REV.
1					CHECKED	TRINATH		16.12.15				09	01	00
2					DRAWN	JAGADISH		16.12.15				09		
3					DESIGNED	JAGADISH		16.12.15				09		
4												09		



BHARAT HEAVY ELECTRICALS LIMITED
ELECTROPROTECTANS DIVISION BANGALORE
POWER & CONTROL SCHEME
BUSCOUPLER CONTROLLED FROM ECP & DDCMS

COPYRIGHT AND CONFIDENTIAL
 The information on the document is the property of BHARAT HEAVY ELECTRICALS LIMITED
 It must not be used directly or indirectly in any way detrimental to the interest of the company

DRG. NO. EP-3-CS-053-003

FIRST ANGLE PROJECTION

ALL DIMENSIONS ARE IN MM

415V, 3PH, 4W, BUS-A, 50HZ, SOKA FOR 1SEC.

415V, 3PH, 4W, BUS-B, 50HZ, SOKA FOR 1SEC.

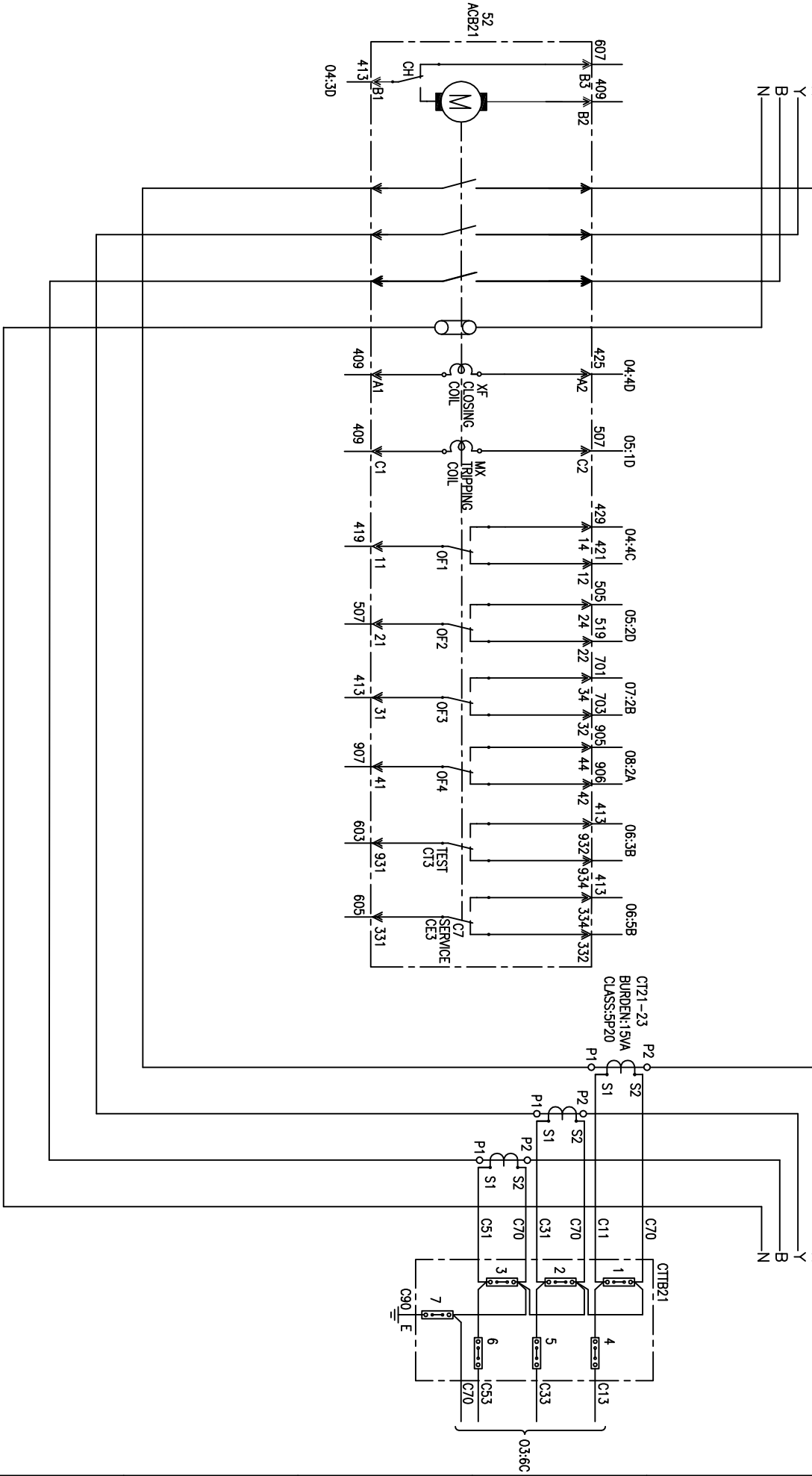

INVENTORY NO.				BY	APPD.	APPROVED	KSB	SCALE: NA	JOB NO. CP-14-053	DRG. NO. EP-3-CS-053-003	NO. OF SHEETS 09
REV. NO.	1	2	3	4							SHEET. NO. 02
DATE											REV. 00
DESCRIPTION				NAME	SIGN.	DATE			BHARAT HEAVY ELECTRICALS LIMITED ELECTROPROTECTIANS DIVISION BANGALORE		
				DESIGNED		16.12.15			TITLE : POWER & CONTROL SCHEME BUSCOUPLER CONTROLLED FROM ECP & DDCMS		
				DRAWN		16.12.15					
				CHECKED	TRINATH	16.12.15					

FORM 66-271 A3

R31, NUMERICAL RELAY TYPE: REF615

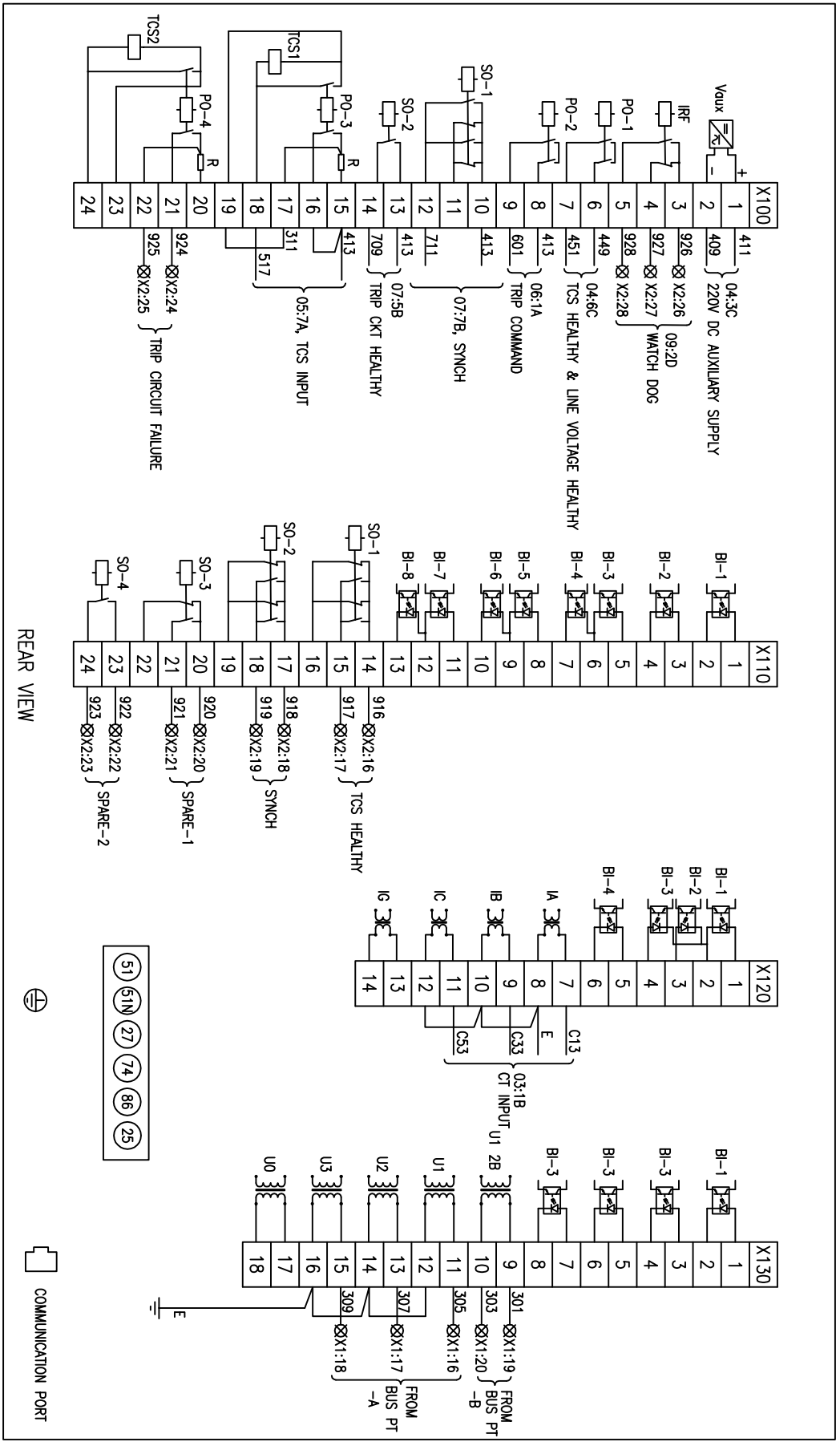

1	2	3	4	5	6	7	8
FIRST ANGLE PROJECTION				ALL DIMENSIONS ARE IN MM			

INVENTORY NO.	4	3	2	1
REV. NO.				
DATE				
DESCRIPTION				
BY				
APPD.				
APPROVED				
KSB				
NAME				
SIGN.				
DATE				
SCALE: NA				
JOB NO. CP-14-053				
DRG. NO. EP-3-CS-053-003				
TITLE:	BHARAT HEAVY ELECTRICALS LIMITED ELECTROPROTECTIANS DIVISION BANGALORE			
	POWER & CONTROL SCHEME BUSCOUPLER CONTROLLED FROM ECP & DDCMS			
NO. OF SHEETS	09			
SHEET NO.	03			
REV.	00			

DRG. NO. EP-3-CS-053-003

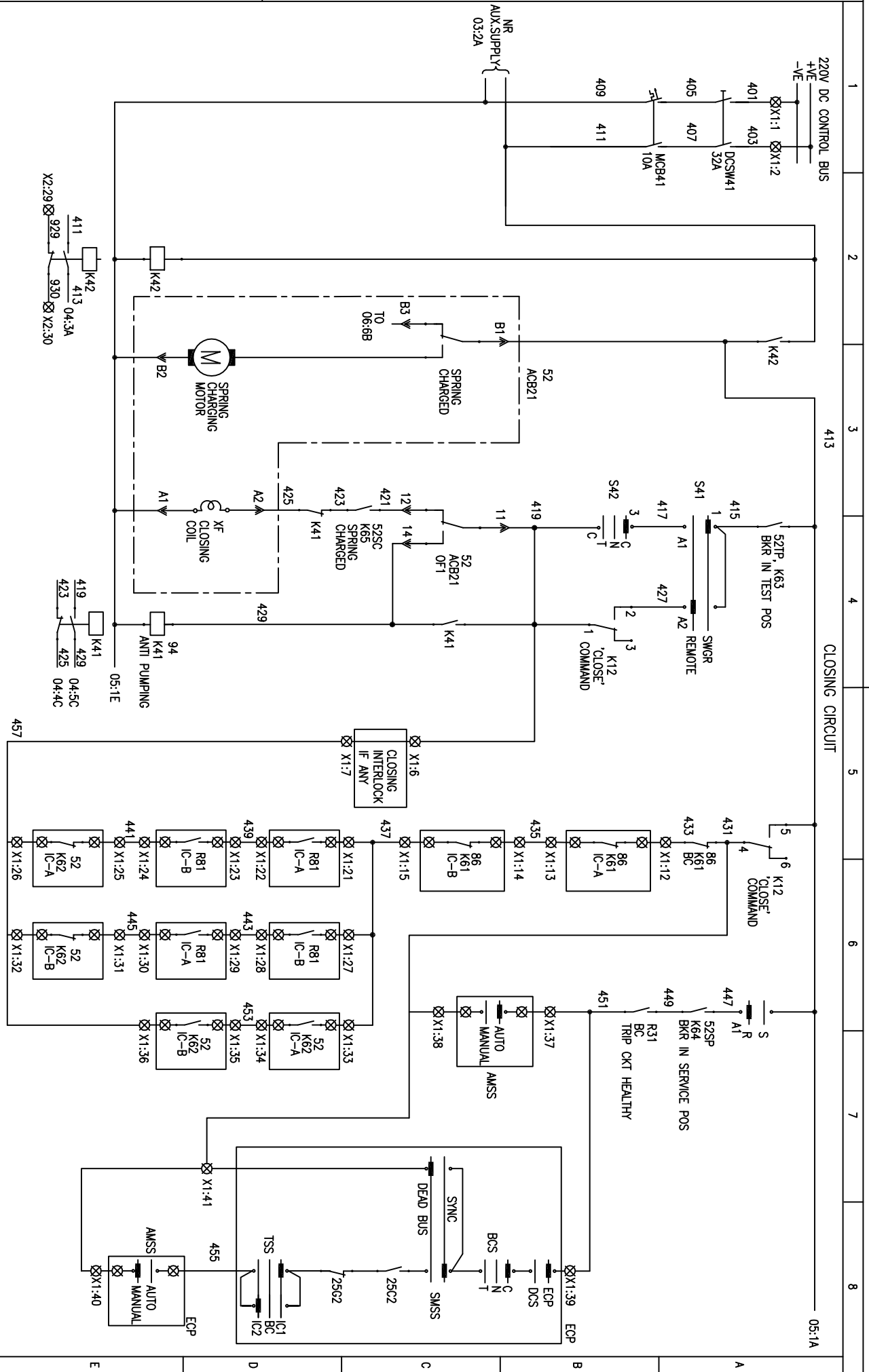

FIRST ANGLE PROJECTION

ALL DIMENSIONS ARE IN MM.

REV. NO.	DATE	DESCRIPTION	BY	APPD.	APPROVED	KSB	SCALE	JOB NO.	DRG. NO.	NO. OF SHEETS	SHEET NO.	REV.
1							NA	CP-14-053	EP-3-CS-053-003	09	04	00
2												
3												
4												

BHARAT HEAVY ELECTRICALS LIMITED
 ELECTROPROTECTIANS DIVISION BANGALORE

POWER & CONTROL SCHEME
 BUSCOUPLER CONTROLLED FROM ECP & DDCMS



NO. OF SHEETS: 09
 SHEET NO.: 04

DRG. NO. EP-3-CS-053-003

FORM 66-271 A3

FIRST ANGLE PROJECTION

ALL DIMENSIONS ARE IN MM.

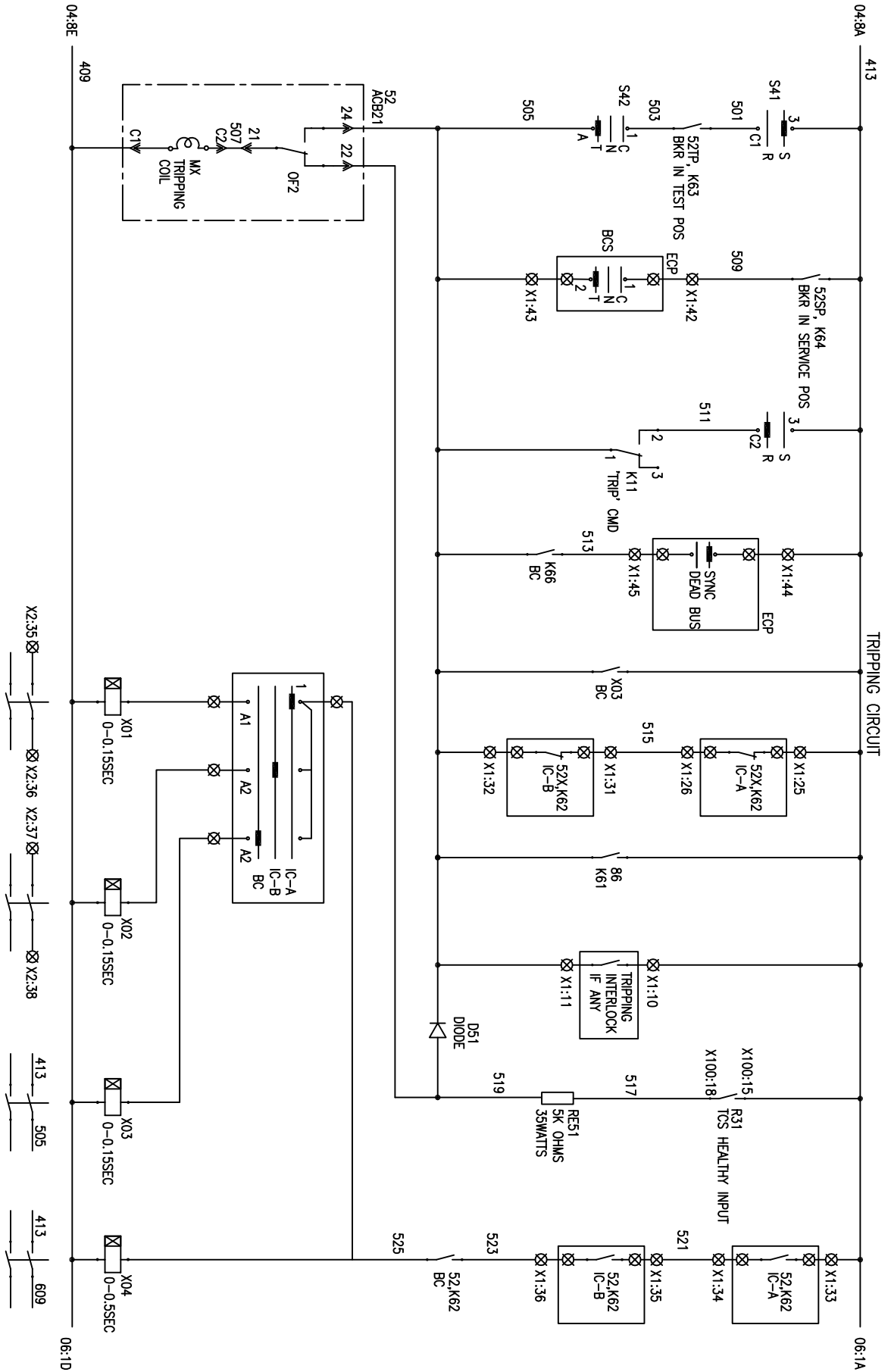

INVENTORY NO.	4	NAME		DATE		SCALE	NA	JOB NO.	CP-14-053	DRG. NO.	EP-3-CS-053-003
REV. NO.	1	SIGN.		16.12.15		BHARAT HEAVY ELECTRICALS LIMITED ELECTROPROTECTIENS DIVISION BANGALORE		TITLE :	POWER & CONTROL SCHEME	NO. OF SHEETS	09
DATE	2			16.12.15		BHARAT HEAVY ELECTRICALS LIMITED			BUSCOUPLER CONTROLLED FROM ECP & DDCMS	SHEET NO.	05
DESCRIPTION	3			16.12.15		BHARAT HEAVY ELECTRICALS LIMITED				REV.	00
BY	4					BHARAT HEAVY ELECTRICALS LIMITED					
APPD.						BHARAT HEAVY ELECTRICALS LIMITED					
APPROVED						BHARAT HEAVY ELECTRICALS LIMITED					
						BHARAT HEAVY ELECTRICALS LIMITED					

RELAY CIRCUIT

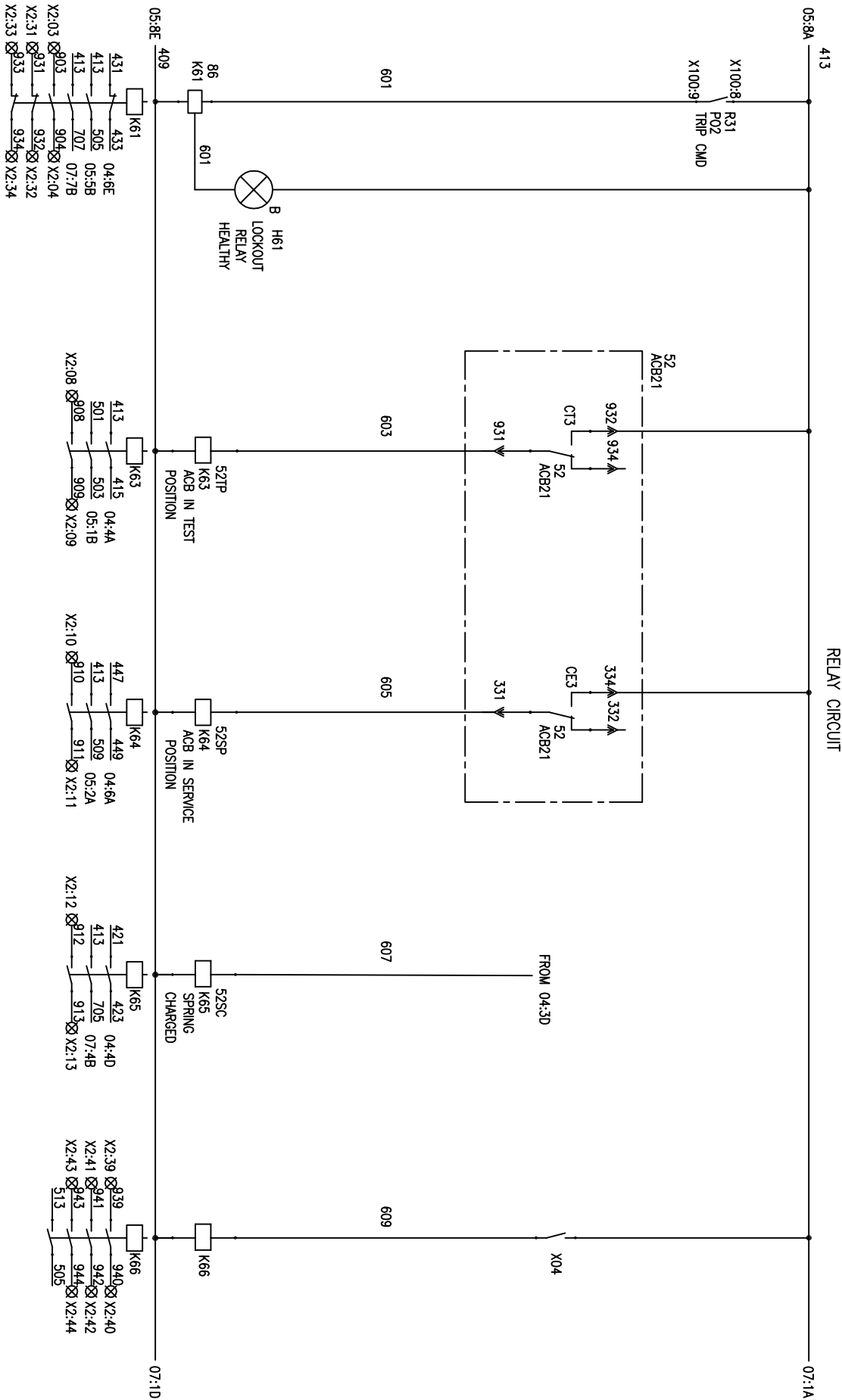

DRG. NO. EP-3-CS-053-003

REV. NO.	DATE	DESCRIPTION	BY	APPD.	APPROVED	KSB	SCALE: NA	JOB NO. CP-14-053	DRG. NO. EP-3-CS-053-003	NO. OF SHEETS	SHEET NO.	REV.
1					CHECKED	TRINATH				09	06	00
2					DRAWN							
3					DESIGNED	JAGADISH						
4												

BHARAT HEAVY ELECTRICALS LIMITED
ELECTROPOWERELANS DIVISION BANGALORE

TITLE : **POWER & CONTROL SCHEME**
BUSCOUPLER CONTROLLED FROM ECP & DDCMS

DRG. NO. EP-3-CS-053-003

INVENTORY NO.

REV. NO.	DATE	DESCRIPTION	BY	APPD.	APPROVED	NAME	SIGN.	DATE	SCALE: NA	JOB NO. CP-14-053	DRG. NO. EP-3-CS-053-003	NO. OF SHEETS	SHEET NO.	REV.
1					CHECKED	TRINATH		16.12.15				09	07	00
2					DRAWN			16.12.15						
3					DESIGNED	JAGADISH		16.12.15						
4														

FIRST ANGLE PROJECTION

ALL DIMENSIONS ARE IN MM.

INDICATION CIRCUIT

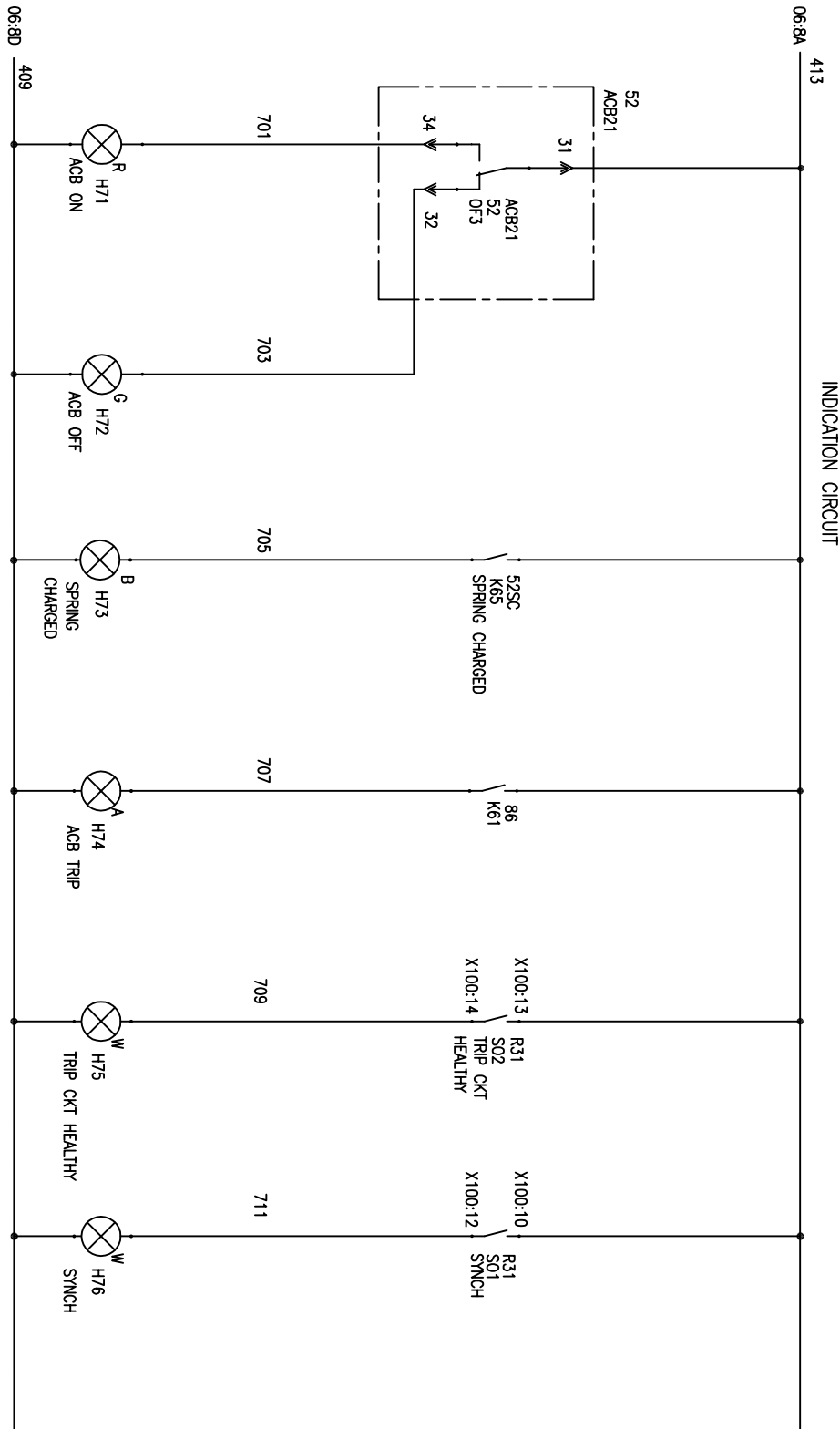

A
B
C
D
E

DRG. NO. EP-3-CS-053-003

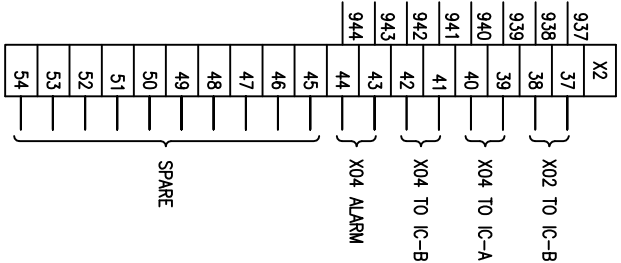
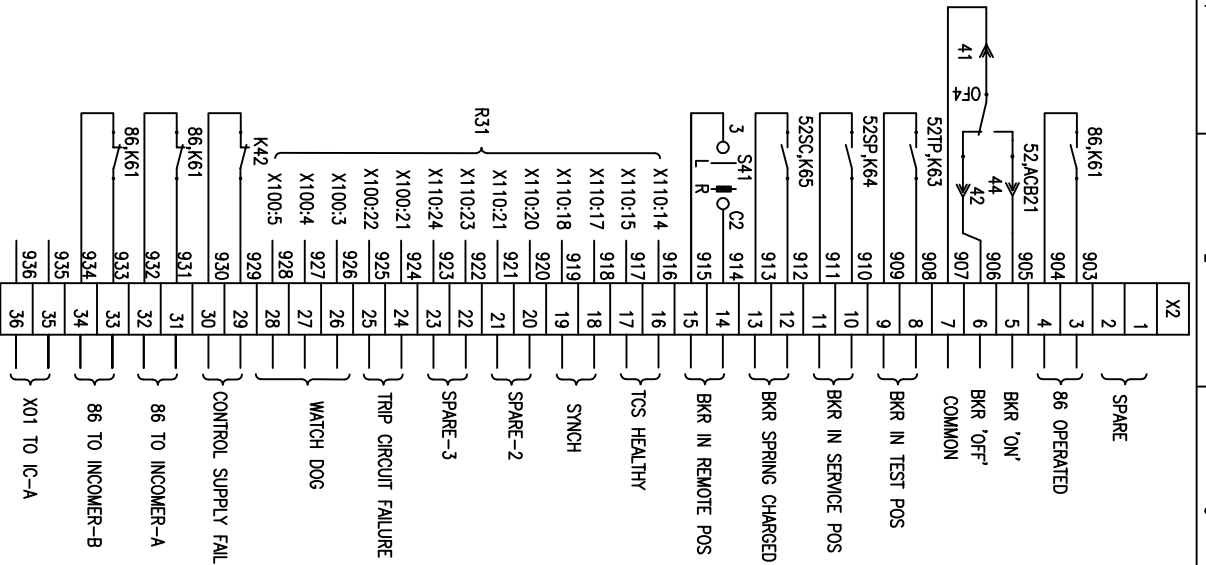

1 FIRST ANGLE PROJECTION 2 3 4 5 ALL DIMENSIONS ARE IN MM. 6 7 8

REV. NO.	DATE	DESCRIPTION	BY	APPD.	APPROVED	KSB	NAME	SIGN.	DATE	SCALE	TITLE	JOB NO.	DRG. NO.	NO. OF SHEETS	SHEET NO.	REV.
1					CHECKED		TRINATH		16.12.15	NA	POWER & CONTROL SCHEME	CP-14-053	EP-3-CS-053-003	09	08	00
2					DRAWN		JAGADISH		16.12.15							
3					DESIGNED		JAGADISH		16.12.15							
4																

BHARAT HEAVY ELECTRICALS LIMITED
ELECTROPROTECTIANS DIVISION BANGALORE



DRG. NO. EP-3-CS-053-003

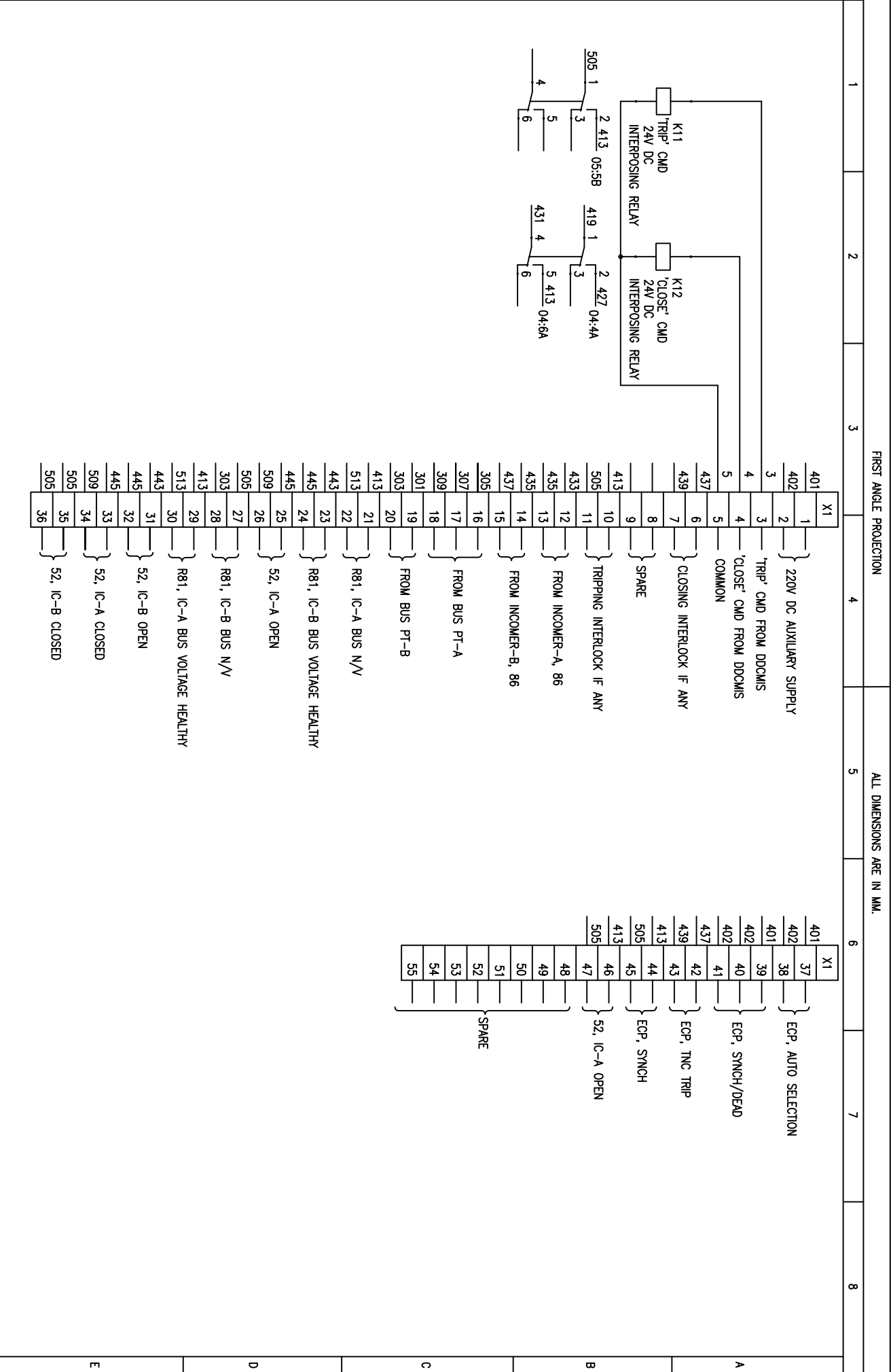

REV. NO.	DATE	DESCRIPTION	BY	APPD.	APPROVED	KSB	NAME	SIGN.	DATE	SCALE	JOB NO.	DRG. NO.	NO. OF SHEETS	REV.
1					CHECKED		TRINATH		16.12.15	MA	CP-14-053	EP-3-CS-053-003	09	00
2					DRAWN		JAGADISH		16.12.15				09	
3					DESIGNED		JAGADISH		16.12.15				09	
4													09	



BHARAT HEAVY ELECTRICALS LIMITED
ELECTROPROTECTIANS DIVISION BANGALORE

TITLE :
POWER & CONTROL SCHEME
BUSCOUPLER CONTROLLED FROM ECP & DDCMIS



NO. OF SHEETS: 09
SHEET NO.: 09

FIRST ANGLE PROJECTION

ALL DIMENSIONS ARE IN MM.

1

2

3

4

5

6

7

8

CUSTOMER:



TELANGANA STATE POWER GENERATION CORPORATION LTD
TELANGANA STATE
INDIA

PROJECT:

4x270 MW BHADRADRI THERMAL POWER STATION
MANUGURU

CUSTOMER CONSULTANT:



DESEIN PRIVATE LTD

COPYRIGHT AND CONFIDENTIAL

The information on the document is the property of BHARAT HEAVY ELECTRICALS LIMITED
It must not be used directly or indirectly in any way detrimental to the interest of the company

DRG. NO. EP-3-CS-053-004

INVENTORY NO.

REV. NO.	DATE	DESCRIPTION	BY	APPD.	APPROVED	NAME	SIGN.	DATE
1					CHECKED	TRINATH		16.12.15
2					DRAWN	JAGADISH		16.12.15
3					DESIGNED	JAGADISH		16.12.15
4								



BHARAT HEAVY ELECTRICALS LIMITED

ELECTROFORCELANS DIVISION BANGALORE

TITLE :

POWER & CONTROL SCHEME
INCOMER-A CONTROLLED FROM DDCMS ONLY

JOB NO. CP-14-053

DRG. NO. EP-3-CS-053-004

NO. OF SHEETS

10

SHEET NO.

01

REV.

00

DRG. NO. EP-3-CS-053-004

INVENTORY NO.

REV. NO.	DATE	DESCRIPTION	BY	APPD.	APPROVED	KSB	SCALE	JOB NO.	DRG. NO.	REV.
1					CHECKED	TRINATH	16.12.15	CP-14-053	EP-3-CS-053-004	00
2					DRAWN					
3					DESIGNED	JAGADISH	16.12.15			
4										

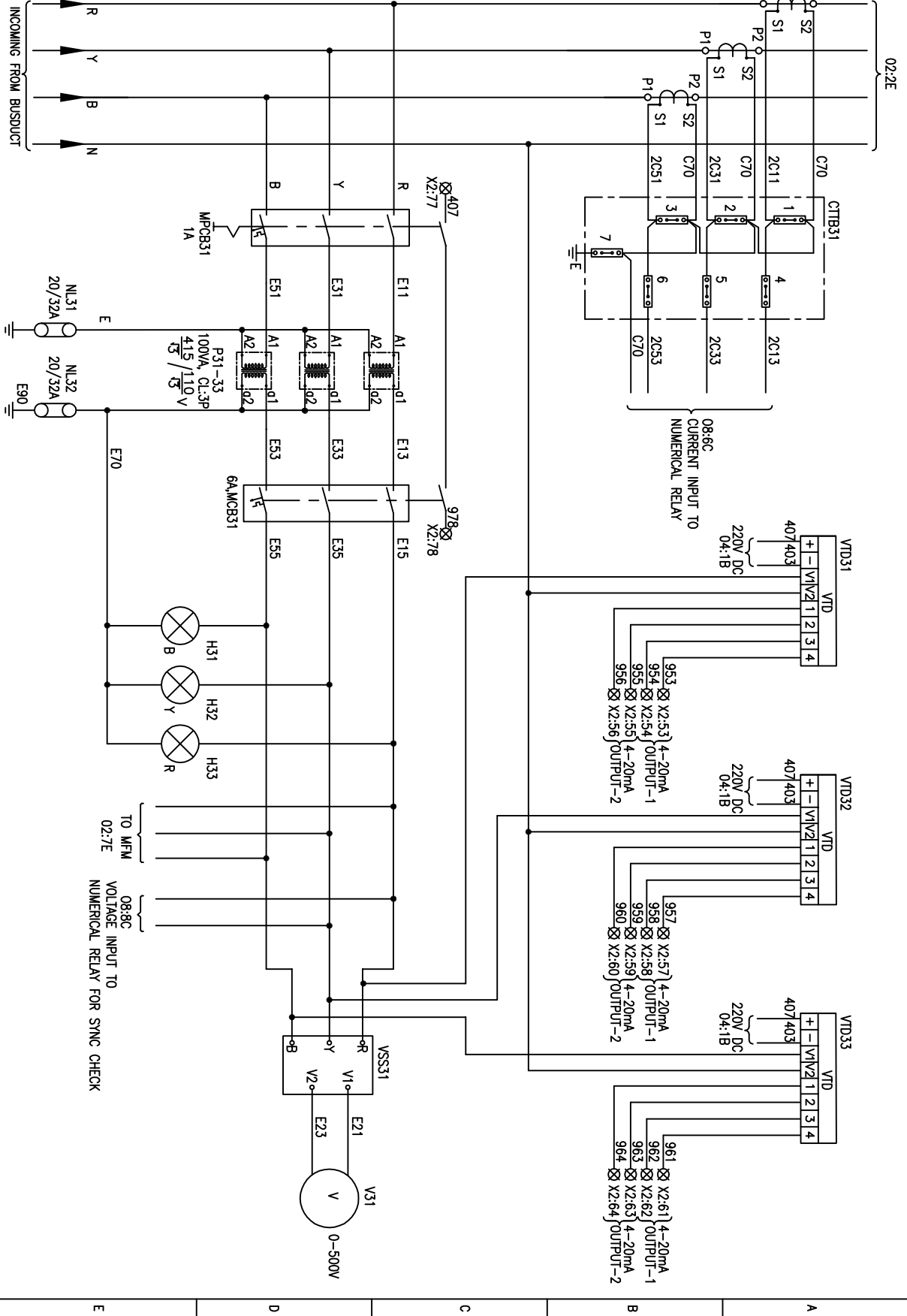

FIRST ANGLE PROJECTION

ALL DIMENSIONS ARE IN MM.

DRG. NO. EP-3-CS-053-004

FORM 66-271 A3

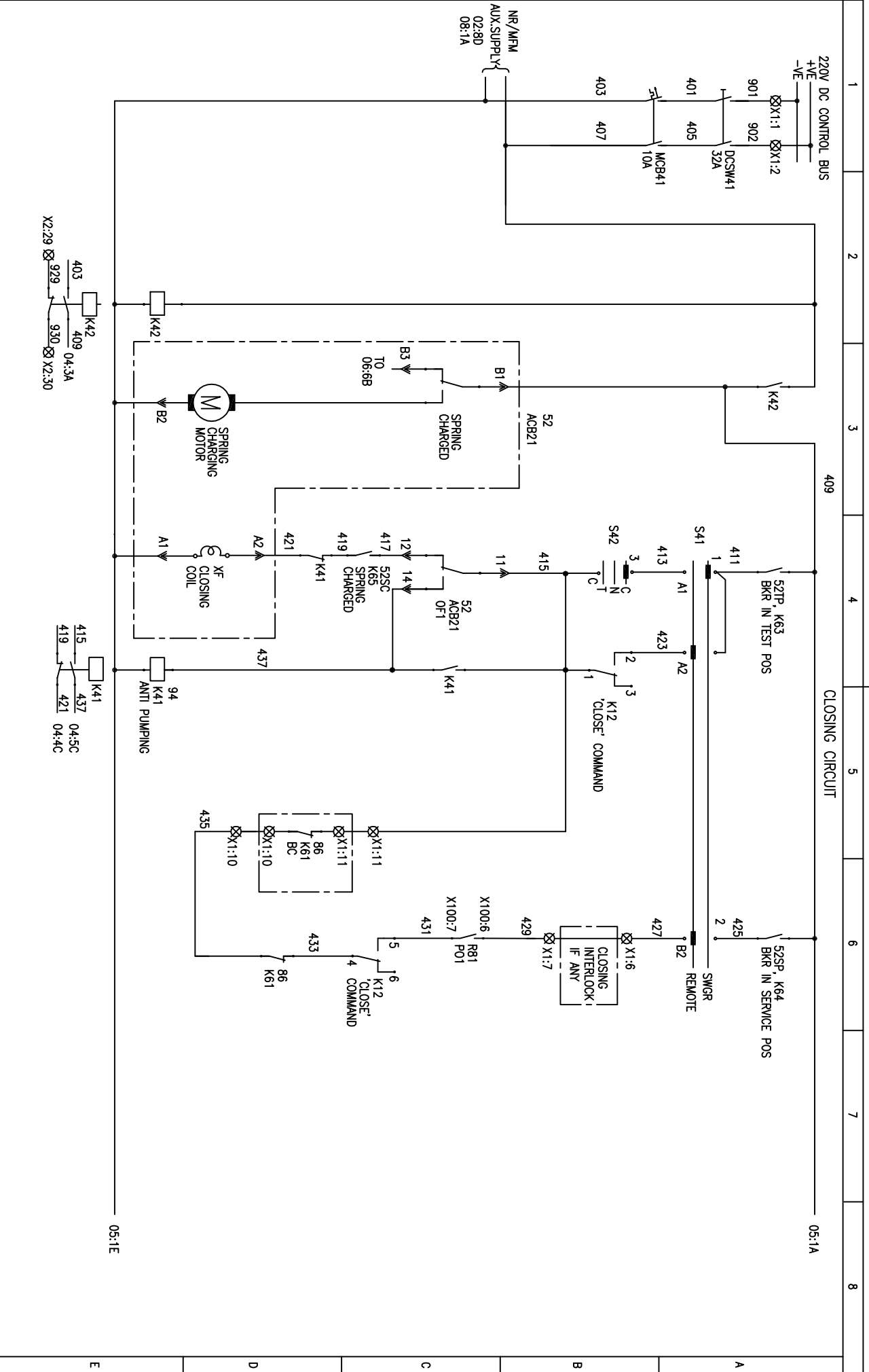

FIRST ANGLE PROJECTION

ALL DIMENSIONS ARE IN MM.

INVENTORY NO.	REV. NO.	DATE	DESCRIPTION	BY	APPD.	APPROVED	KSB	SCALE: NA	JOB NO. CP-14-053	DRG. NO. EP-3-CS-053-004
4										
3										
2										
1										

BHARAT HEAVY ELECTRICALS LIMITED
ELECTROPOWERCELLS DIVISION BANGALORE

TITLE : **POWER & CONTROL SCHEME**
INCOMER-A CONTROLLED FROM DDCMIS ONLY

NO. OF SHEETS	10
SHEET NO.	04
REV. NO.	00

DRG. NO. EP-3-CS-053-004

FORM 66-271 A3

FIRST ANGLE PROJECTION
ALL DIMENSIONS ARE IN MM

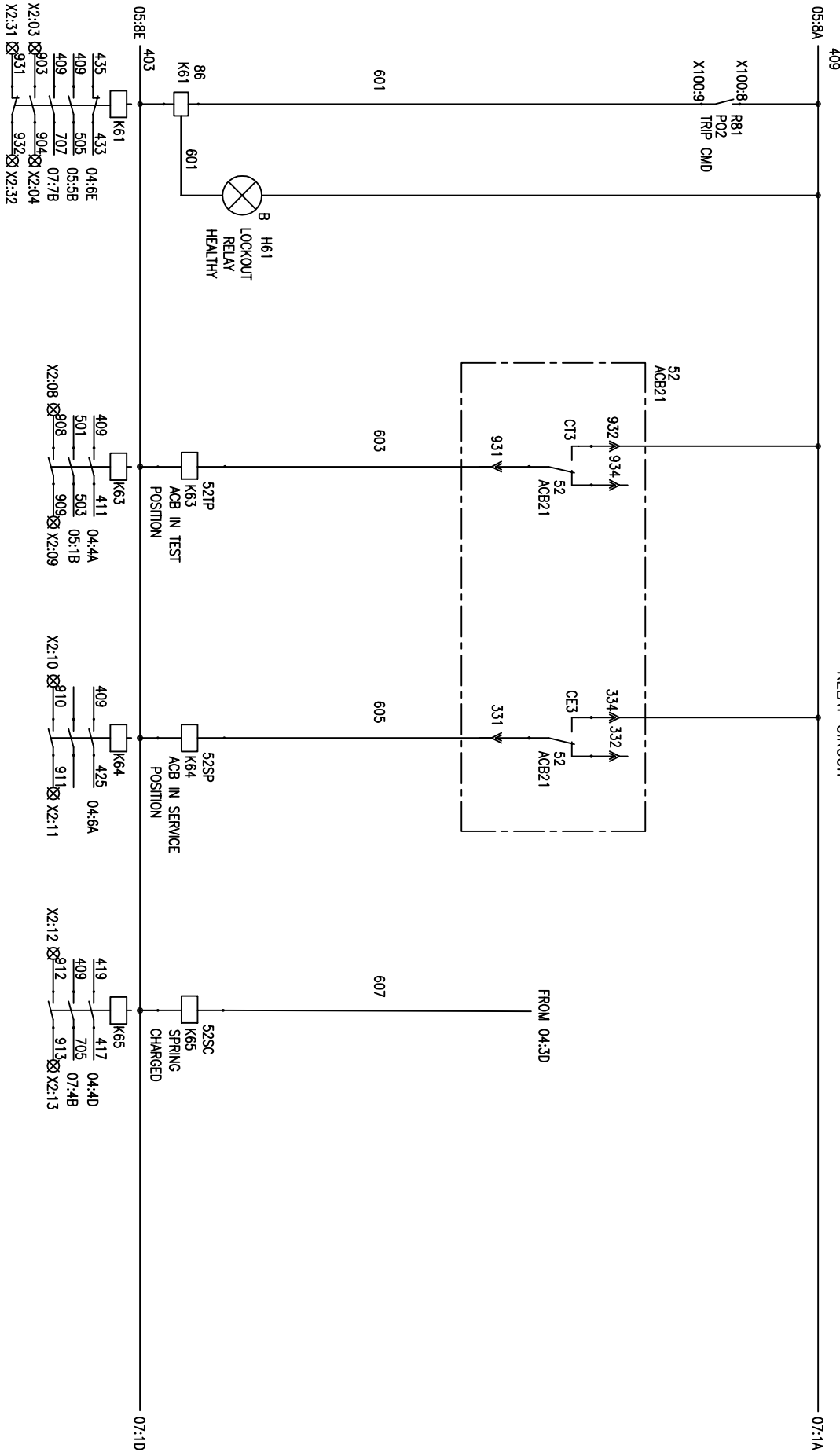

REV. NO.	DATE	DESCRIPTION	BY	APPD.	APPROVED	KSB	SCALE: NA	JOB NO. CP-14-053	DRG. NO. EP-3-CS-053-004	REV. NO.
1					CHECKED	TRINATH				06
2					DRAWN					10
3					DESIGNED	JAGADISH				
4										

BHARAT HEAVY ELECTRICALS LIMITED
ELECTROPROTECTIVES DIVISION BANGALORE



TITLE :
POWER & CONTROL SCHEME
INCOMER-A CONTROLLED FROM DDGMS ONLY

NO. OF SHEETS: 10
SHEET NO.: 06
REV. NO.: 00

DRG. NO. EP-3-CS-053-004

INVENTORY NO.

FIRST ANGLE PROJECTION

ALL DIMENSIONS ARE IN MM.

8

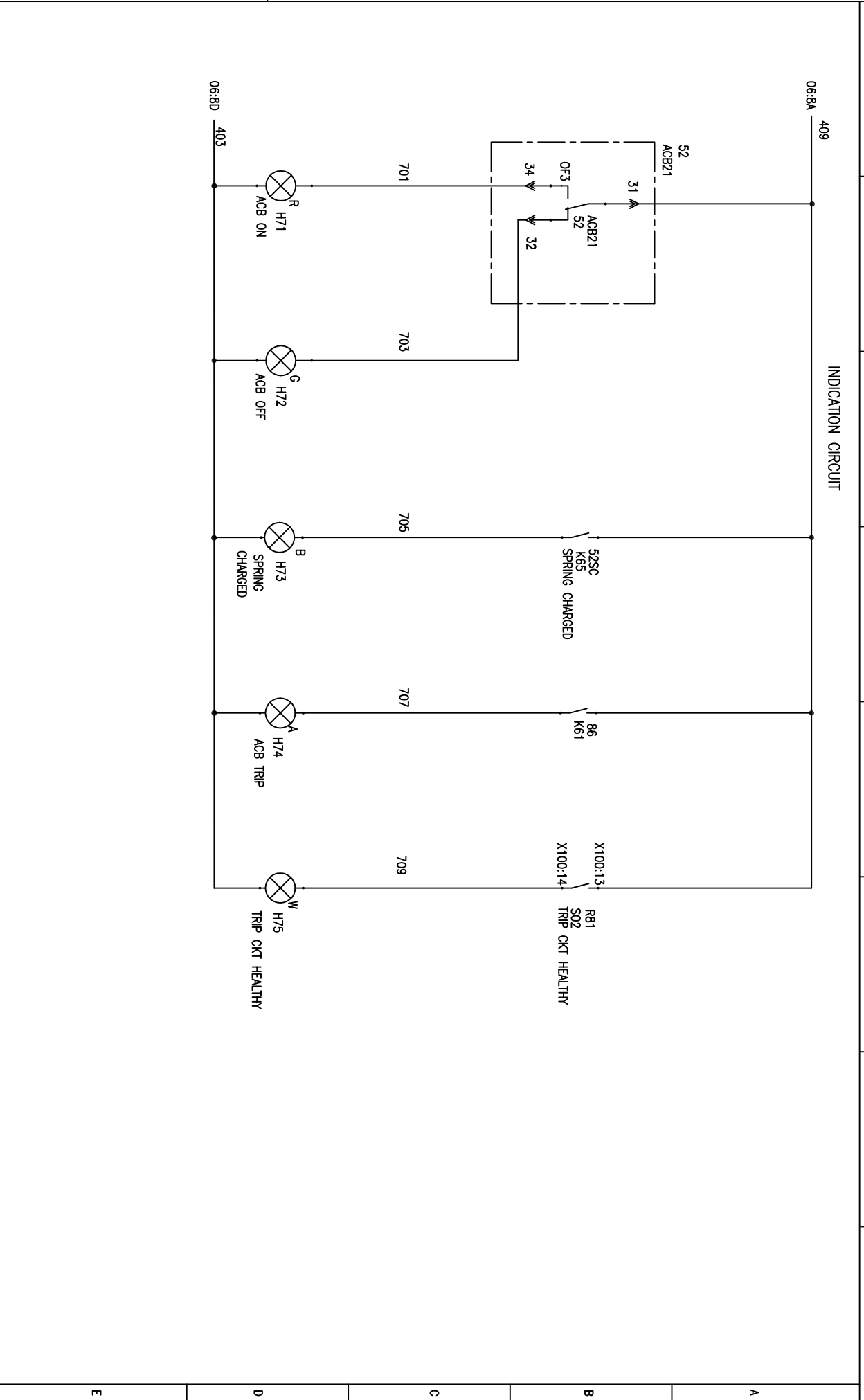

REV. NO.	DATE	DESCRIPTION	BY	APPD.	APPROVED	KSB	SCALE: NA	JOB NO. CP-14-053	DRG. NO. EP-3-CS-053-004	NO. OF SHEETS	SHEET NO.	REV.
1					CHECKED	TRINATH				10	07	00
2					DRAWN							
3					DESIGNED	JAGADISH						
4												

BHARAT HEAVY ELECTRICALS LIMITED
ELECTROPOWERCELLS DIVISION BANGALORE

POWER & CONTROL SCHEME
INCOMER-A CONTROLLED FROM DDCMS ONLY



NO. OF SHEETS: 10
SHEET NO.: 07

The information on the document is the property of BHARAT HEAVY ELECTRICALS LIMITED
It must not be used directly or indirectly in any way detrimental to the interest of the company

DRG. NO. EP-3-CS-053-004

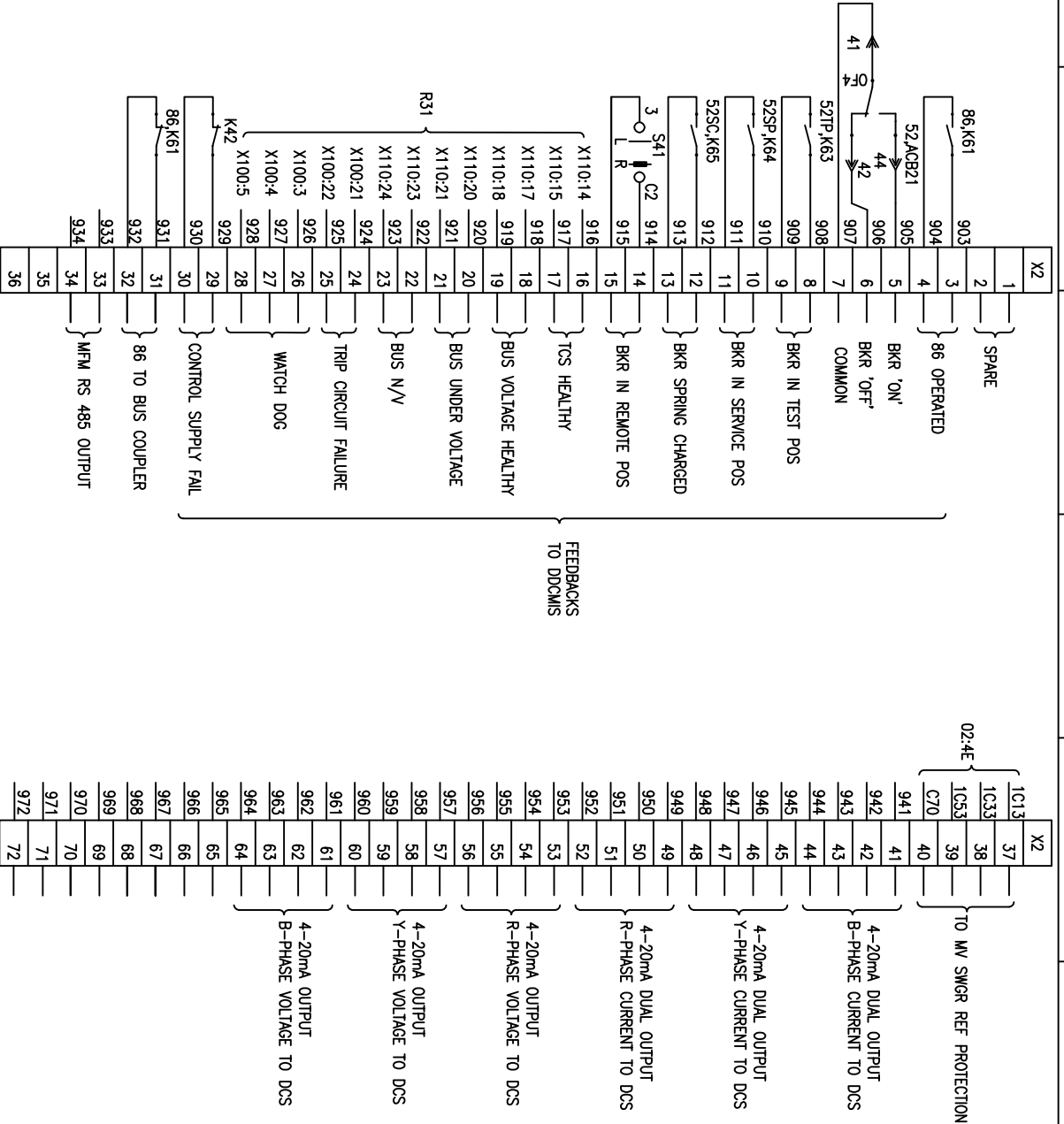

FIRST ANGLE PROJECTION
ALL DIMENSIONS ARE IN MM

REV. NO.	DATE	DESCRIPTION	BY	APPD.	APPROVED	KSB	NAME	SIGN.	DATE	SCALE	JOB NO.	DRG. NO.	NO. OF SHEETS	SHEET NO.	REV.
1					CHECKED		TRINATH		16.12.15	MA	CP-14-053	EP-3-CS-053-004	10	09	00
2					DRAWN										
3					DESIGNED		JAGADISH		16.12.15						
4															

BHARAT HEAVY ELECTRICALS LIMITED
ELECTROPOWERCELLS DIVISION BANGALORE

TITLE :
POWER & CONTROL SCHEME
INCOMER-A CONTROLLED FROM DDCMS ONLY



DRG. NO. EP-3-CS-053-004

INVENTORY NO.

REV. NO.	DATE	DESCRIPTION	BY	APPD.	APPROVED	KSB	NAME	SIGN.	DATE	SCALE	JOB NO.	DRG. NO.	NO. OF SHEETS	REV.
1					CHECKED	TRINATH			16.12.15	NA	CP-14-053	EP-3-CS-053-004	10	00
2					DRAWN								10	
3					DESIGNED	JAGADISH			16.12.15				10	
4													10	

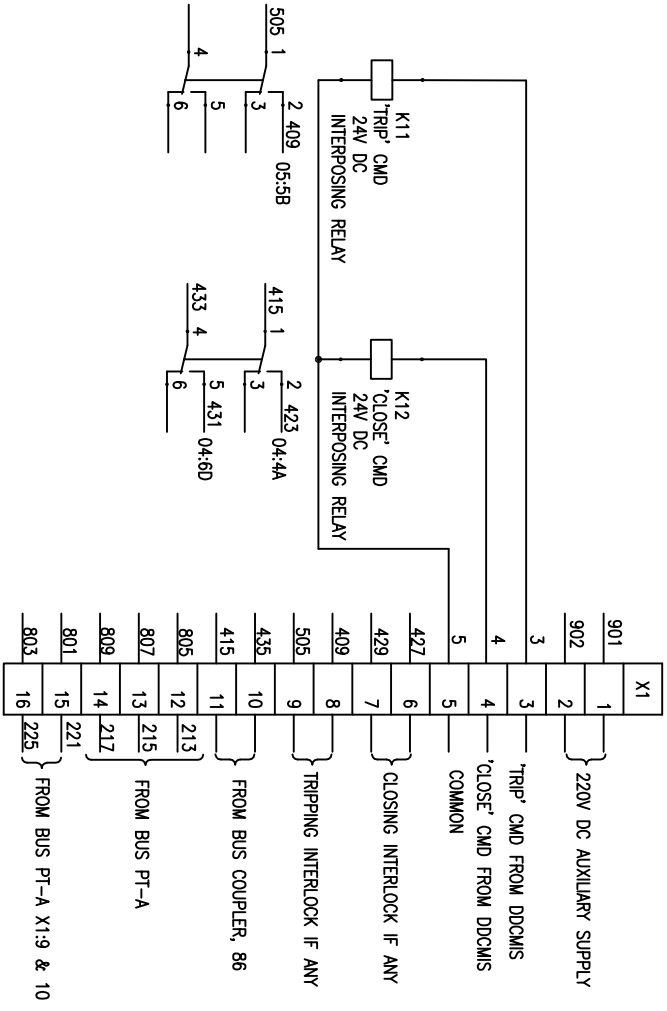

1 2 3 4 5 6 7 8

FIRST ANGLE PROJECTION

ALL DIMENSIONS ARE IN MM.

BHARAT HEAVY ELECTRICALS LIMITED
ELECTROPROTECTIVES DIVISION BANGALORE

POWER & CONTROL SCHEME
INCOMER-A CONTROLLED FROM DDCMIS ONLY



NO. OF SHEETS: 10
SHEET NO.: 10

FIRST ANGLE PROJECTION

ALL DIMENSIONS ARE IN MM.

1

2

3

4

5

6

7

8

CUSTOMER:



TELANGANA STATE POWER GENERATION CORPORATION LTD
TELANGANA STATE
INDIA

PROJECT:

4x270 MW BHADRADRI THERMAL POWER STATION
MANUGURU

CUSTOMER CONSULTANT:

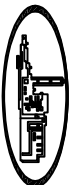

DESEIN PRIVATE LTD

COPYRIGHT AND CONFIDENTIAL

The information on the document is the property of BHARAT HEAVY ELECTRICALS LIMITED
It must not be used directly or indirectly in any way detrimental to the interest of the company

DRG. NO. EP-3-CS-053-005

INVENTORY NO.

REV. NO.	DATE	DESCRIPTION	BY	APPD.	APPROVED	NAME	SIGN.	DATE
1					CHECKED	TRINATH		16.12.15
2					DRAWN	JAGADISH		16.12.15
3					DESIGNED	JAGADISH		16.12.15
4								



BHARAT HEAVY ELECTRICALS LIMITED

ELECTROPOWERCELLS DIVISION BANGALORE

TITLE :

POWER & CONTROL SCHEME
INCOMER-B CONTROLLED FROM DDCMS ONLY

JOB NO. CP-14-053

DRG. NO. EP-3-CS-053-005



NO. OF SHEETS

01



REV.

00

DRG. NO. EP-3-CS-053-005

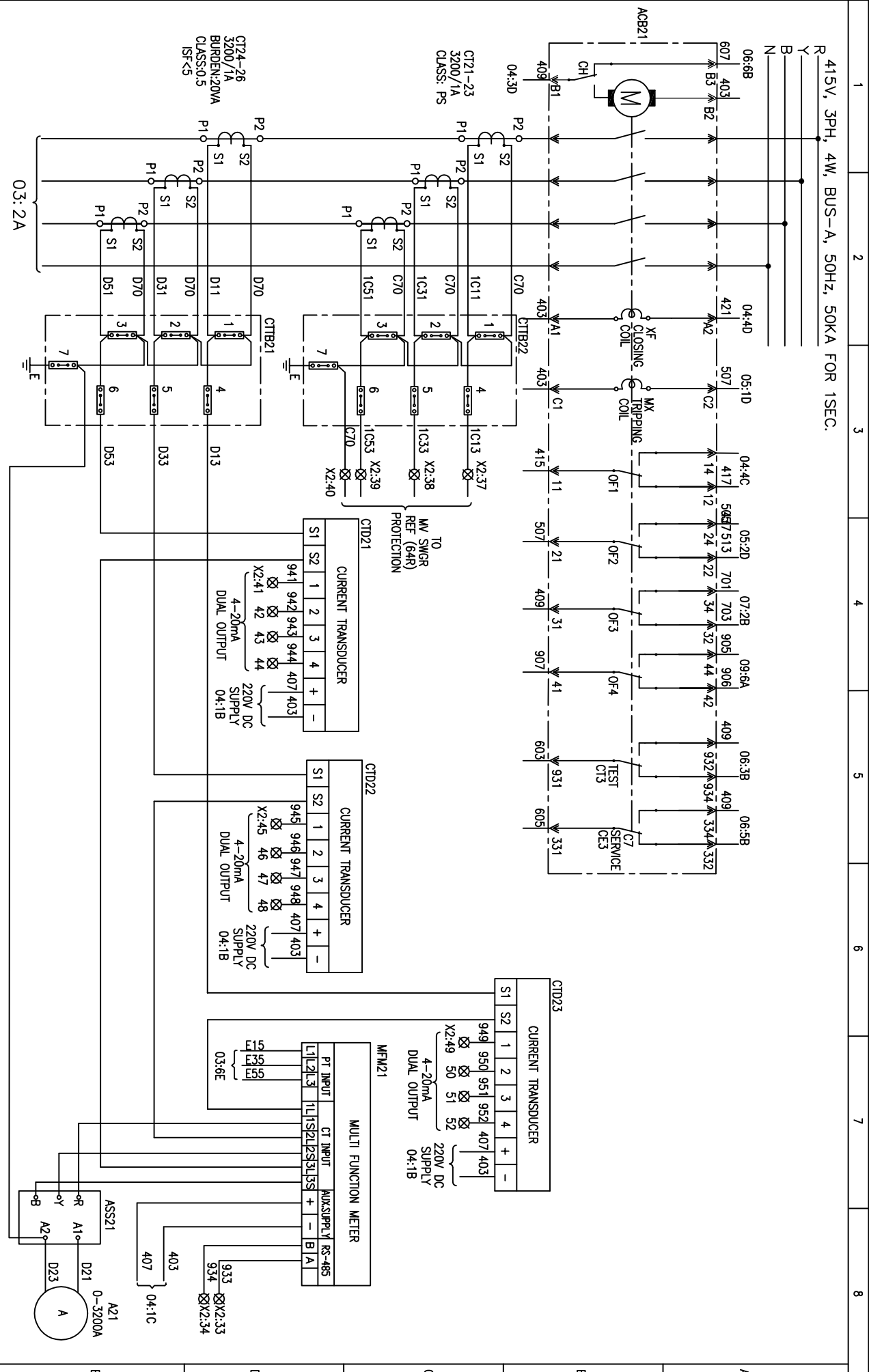

FIRST ANGLE PROJECTION

ALL DIMENSIONS ARE IN MM.

INVENTORY NO.	4	NAME	DESIGNED	DATE	16.12.15
REV. NO.	1	CHECKED	TRINATH	DATE	16.12.15
DATE		BY	KSB	APPD.	16.12.15
DESCRIPTION	BHARAT HEAVY ELECTRICALS LIMITED ELECTROPROTECTANS DIVISION BANGALORE				
	TITLE : POWER & CONTROL SCHEME				
	INCOMER-B CONTROLLED FROM DDCMS ONLY				
	JOB NO.	CP-14-053	DRG. NO.	EP-3-CS-053-005	
	NO. OF SHEETS	10	SHEET NO.	02	REV. NO.
					00

DRG. NO. EP-3-CS-053-005

INVENTORY NO.	4	NAME		DATE		SCALE	NA	JOB NO.	CP-14-053	DRG. NO.	EP-3-CS-053-005	
REV. NO.	1	SIGNL.		16.12.15				TITLE :	BHARAT HEAVY ELECTRICALS LIMITED ELECTROPROTECTIANS DIVISION BANGALORE POWER & CONTROL SCHEME INCOMER-B CONTROLLED FROM DDGMS ONLY			
DATE		DESIGNED	JAGADISH	16.12.15		NO. OF SHEETS: 10 SHEET NO.: 03		NO. OF SHEETS				
DESCRIPTION		DRAWN						CHECKED	TRINATH	16.12.15		
BY		APPROVED						APPD.			REV.	
		KSB									00	

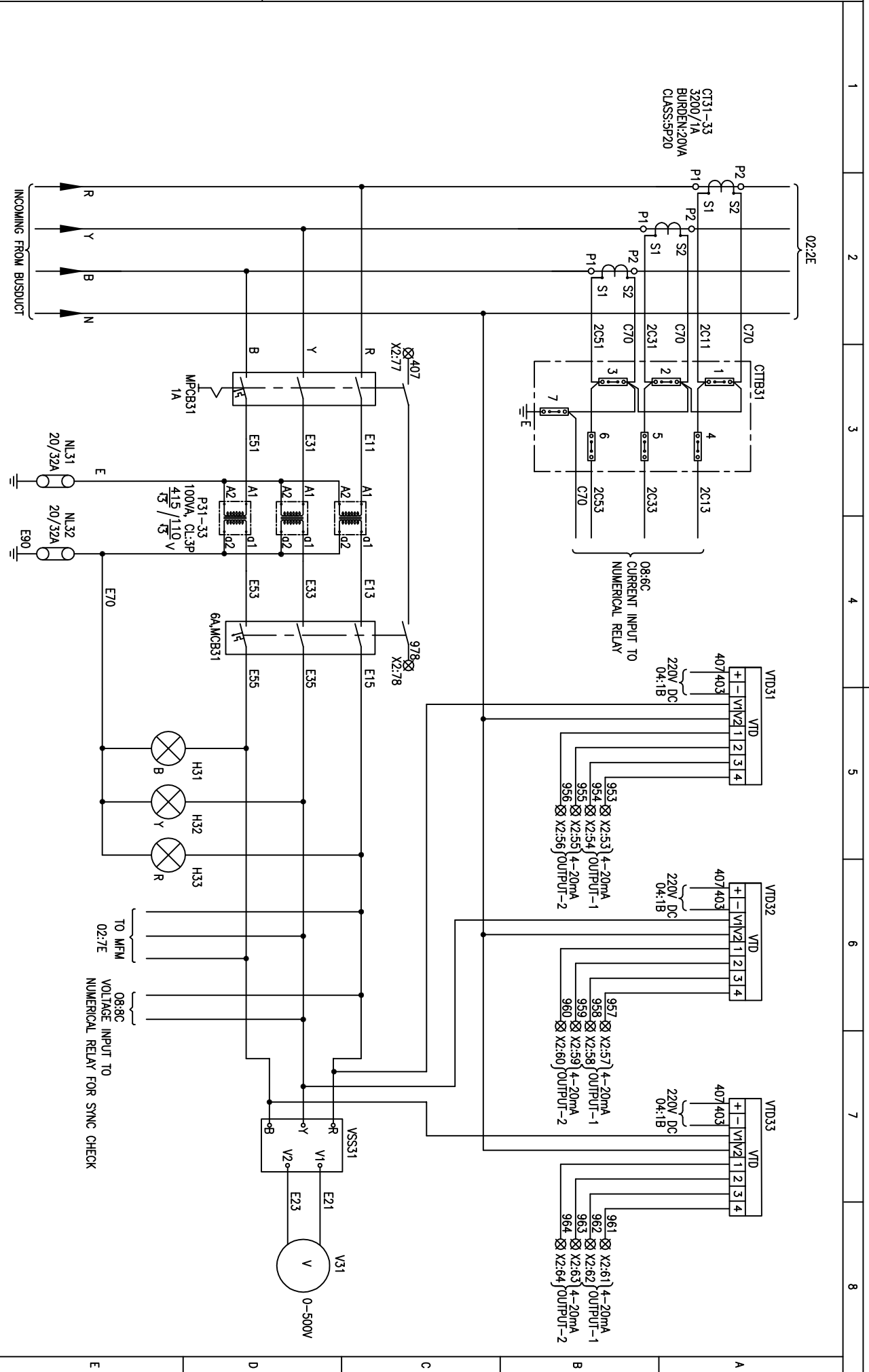

FIRST ANGLE PROJECTION

ALL DIMENSIONS ARE IN MM.

DRG. NO. EP-3-CS-053-005

FORM 66-271 A3

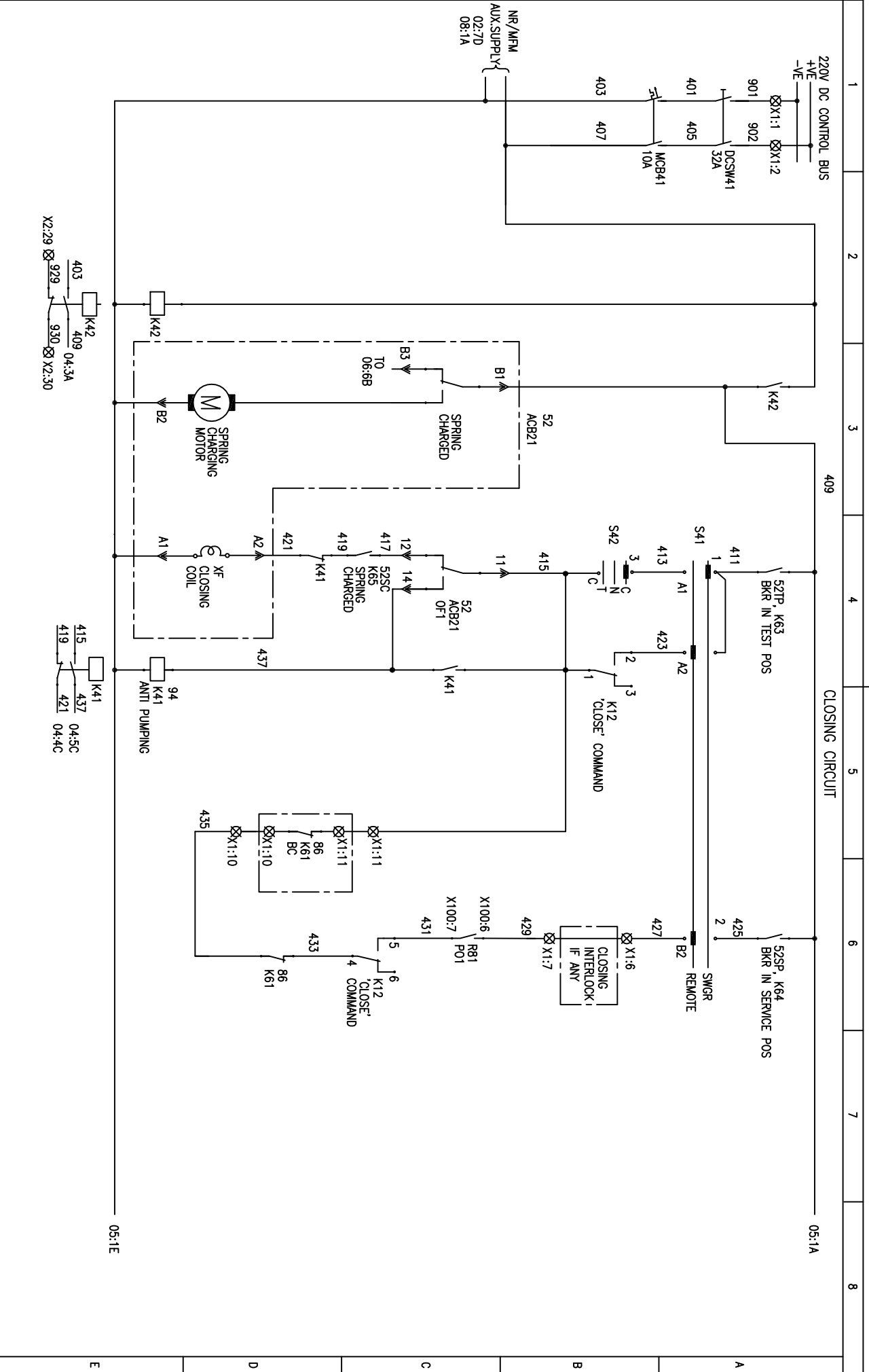

FIRST ANGLE PROJECTION

ALL DIMENSIONS ARE IN MM.

CLOSING CIRCUIT

REV. NO.	DATE	DESCRIPTION	BY	APPD.	APPROVED	KSB	SCALE: NA	JOB NO. CP-14-053	DRG. NO. EP-3-CS-053-005	NO. OF SHEETS	SHEET NO.	REV.
1					CHECKED	TRINATH				10	04	
2					DRAWN							
3					DESIGNED	JAGADISH						
4												

BHARAT HEAVY ELECTRICALS LIMITED
ELECTROPOWERCELLS DIVISION BANGALORE

TITLE :
POWER & CONTROL SCHEME
INCOMER-B CONTROLLED FROM DDCMIS ONLY



NO. OF SHEETS: 10
SHEET NO.: 04
REV.: 00

DRG. NO. EP-3-CS-053-005

FORM 66-271 A3

FIRST ANGLE PROJECTION

ALL DIMENSIONS ARE IN MM.

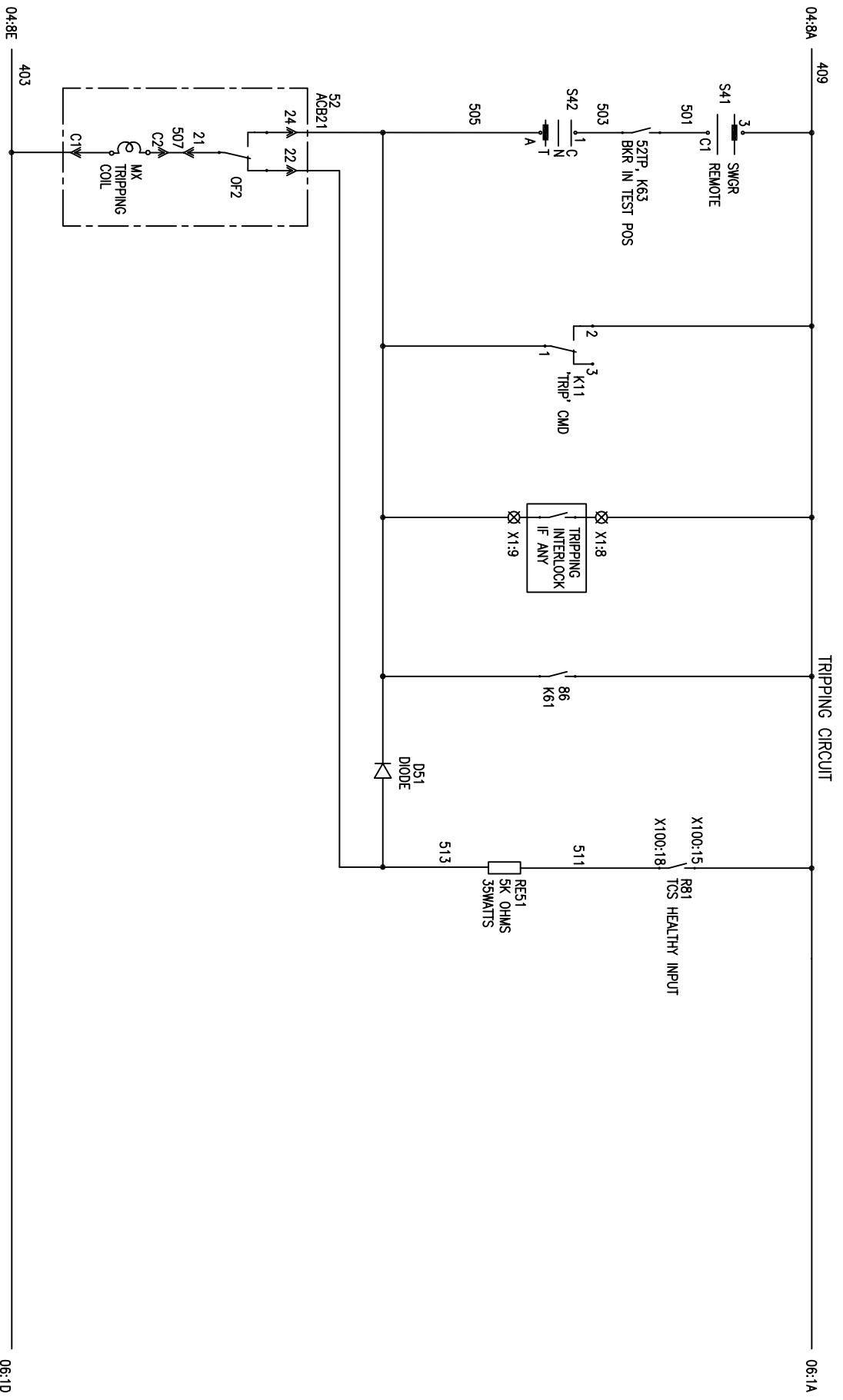

REV. NO.	DATE	DESCRIPTION	BY	APPD.	APPROVED	KSB	SCALE	JOB NO.	DRG. NO.	NO. OF SHEETS	SHEET NO.	REV.
1					CHECKED	TRINATH	16.12.15	CP-14-053	EP-3-CS-053-005	10	05	
2					DRAWN							
3					DESIGNED	JAGADISH	16.12.15					
4												

BHARAT HEAVY ELECTRICALS LIMITED
ELECTROPOWERCELLS DIVISION BANGALORE

POWER & CONTROL SCHEME
INCOMER-B CONTROLLED FROM DCOMS ONLY



NO. OF SHEETS: 10

SHEET NO.: 05

REV. 00

DRG. NO. EP-3-CS-053-005

INVENTORY NO.

FIRST ANGLE PROJECTION

ALL DIMENSIONS ARE IN MM.

INDICATION CIRCUIT

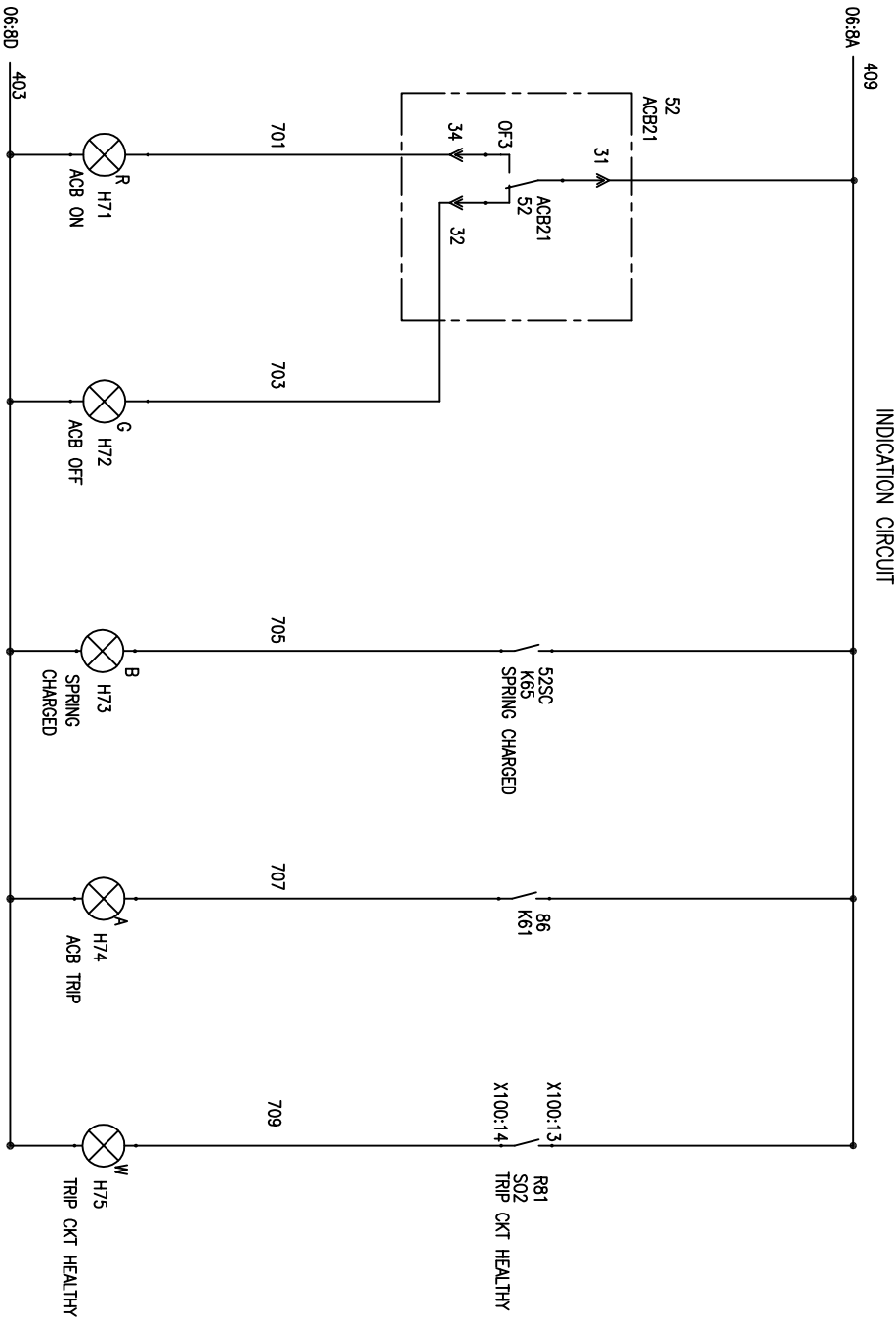

REV. NO.	DATE	DESCRIPTION	BY	APPD.	APPROVED	KSB	SCALE: NA	JOB NO. CP-14-053	DRG. NO. EP-3-CS-053-005	NO. OF SHEETS	SHEET NO.	REV.
1					CHECKED	TRINATH				10	07	00
2					DRAWN							
3					DESIGNED	JAGADISH						
4												

BHARAT HEAVY ELECTRICALS LIMITED
ELECTROPOWERCELLS DIVISION BANGALORE

TITLE :
POWER & CONTROL SCHEME
INCOMER-B CONTROLLED FROM DDCMS ONLY



R81, NUMERICAL RELAY TYPE: REF615

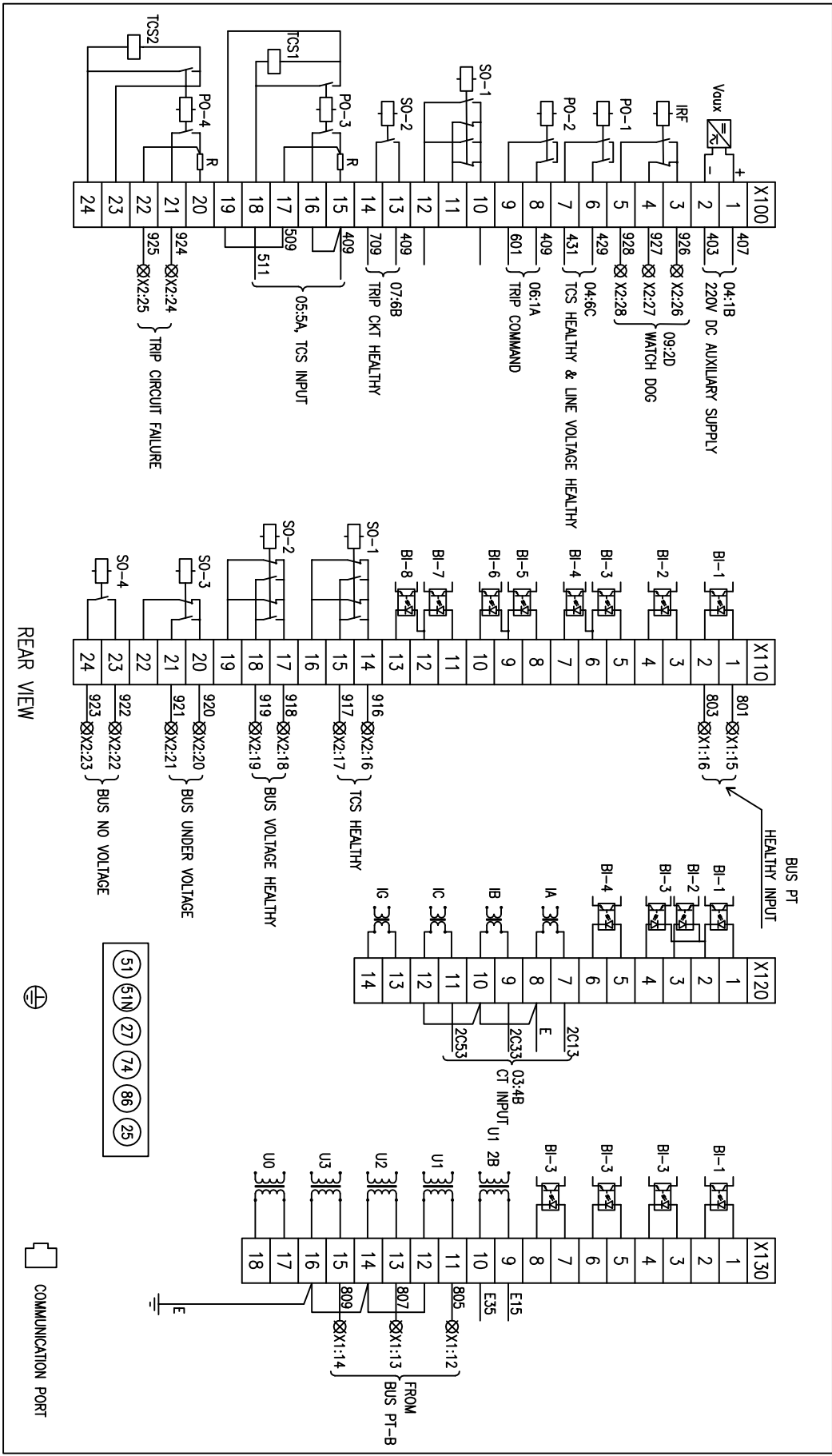

COPYRIGHT AND CONFIDENTIAL
The information on the document is the property of BHARAT HEAVY ELECTRICALS LIMITED
It must not be used directly or indirectly in any way detrimental to the interest of the company

DRG. NO. EP-3-CS-053-005

INVENTORY NO.	REV. NO.	DATE	DESCRIPTION	BY	APPD.	APPROVED	NAME	SIGN.	DATE	SCALE	JOB NO.	DRG. NO.	NO. OF SHEETS	SHEET NO.	REV.
4	1										CP-14-053	EP-3-CS-053-005	10	08	00
3	2						JAGADISH		16.12.15						
2															
1							TRINATH		16.12.15						



BHARAT HEAVY ELECTRICALS LIMITED
ELECTROPOWERTECHNICALS DIVISION BANGALORE

TITLE :
POWER & CONTROL SCHEME
INCOMER-B CONTROLLED FROM DDGMS ONLY



COMMUNICATION PORT

DRG. NO. EP-3-CS-053-005

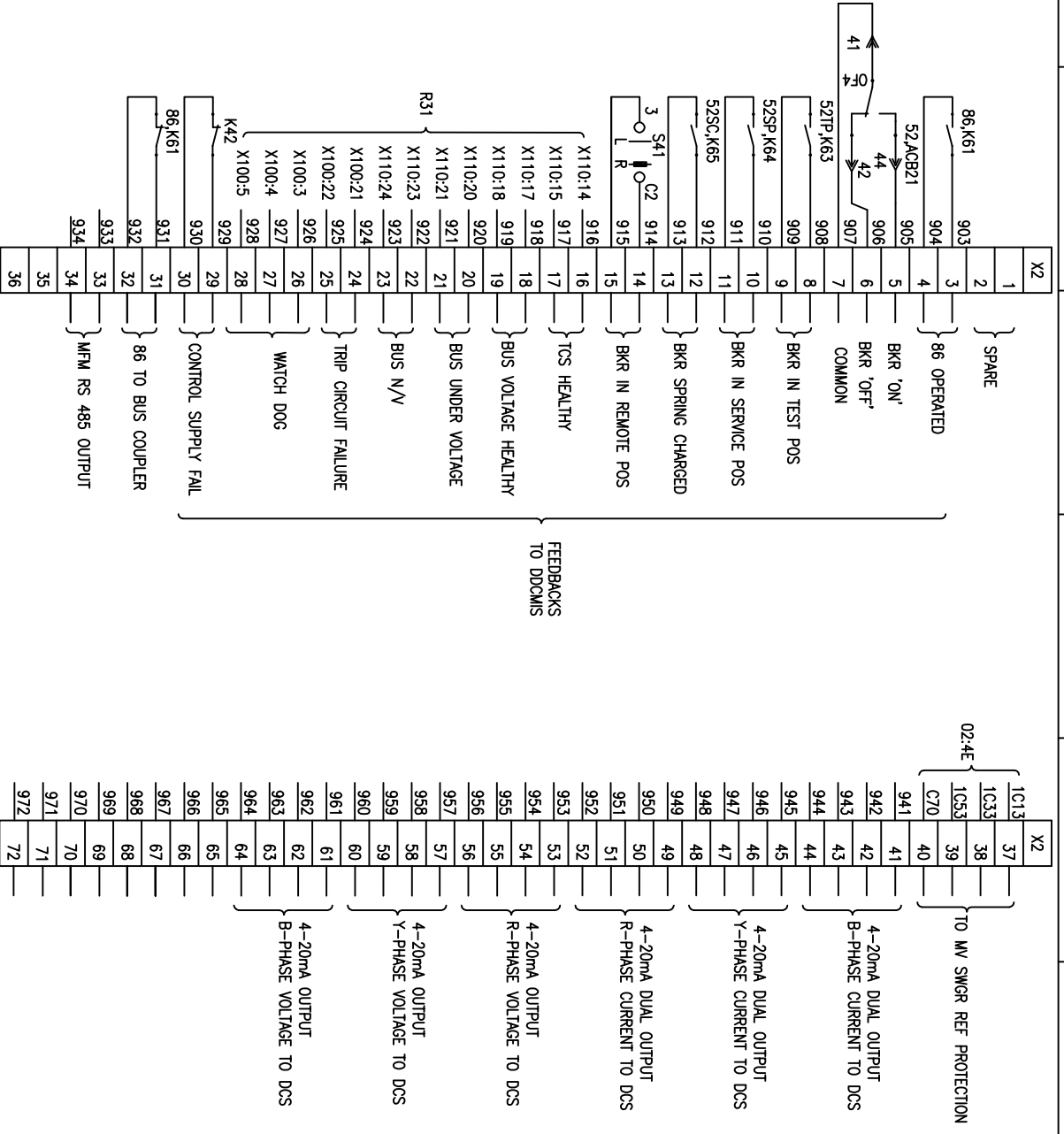

FIRST ANGLE PROJECTION

ALL DIMENSIONS ARE IN MM.

INVENTORY NO.	REV. NO.	DATE	DESCRIPTION	BY	APPD.	APPROVED	KSB	NAME	SIGN.	DATE	SCALE: NA	JOB NO. CP-14-053	DRG. NO. EP-3-CS-053-005	NO. OF SHEETS	NO. OF SHEETS	REV.
4	1							JAGADISH		16.12.15				10	09	00
3	2							TRINATH		16.12.15						
2																
1																

BHARAT HEAVY ELECTRICALS LIMITED
ELECTROPOWERCELLS DIVISION BANGALORE

TITLE :
POWER & CONTROL SCHEME
INCOMER-B CONTROLLED FROM DDCMS ONLY



DRG. NO. EP-3-CS-053-005

FIRST ANGLE PROJECTION

ALL DIMENSIONS ARE IN MM.

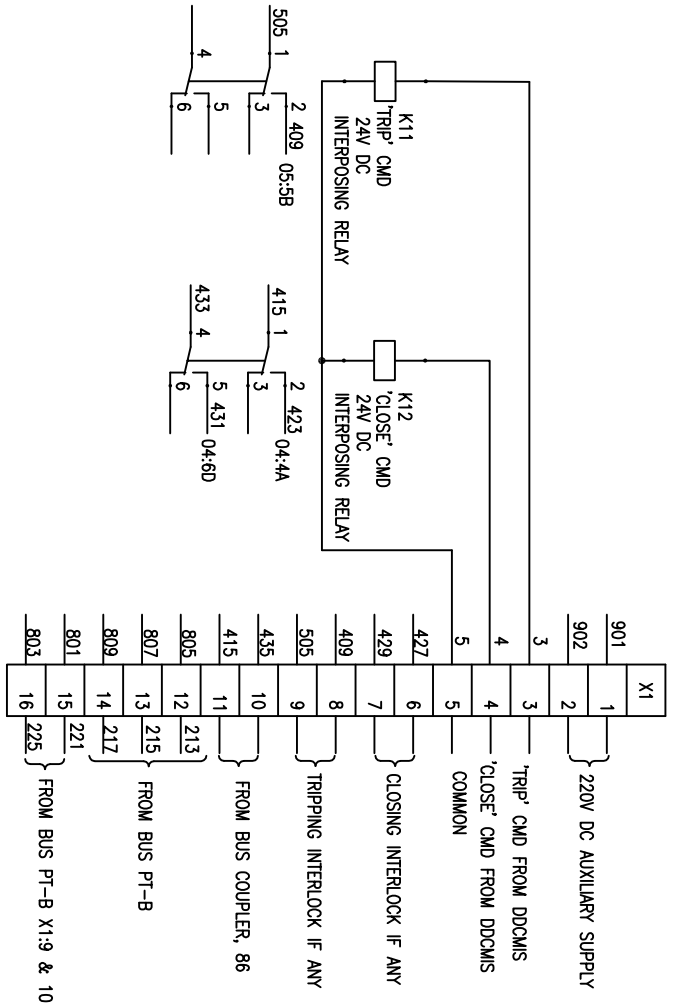

REV. NO.	DATE	DESCRIPTION	BY	APPD.	APPROVED	KSB	NAME	SIGN.	DATE	SCALE	JOB NO.	DRG. NO.	NO. OF SHEETS	REV.
1					CHECKED	TRINATH			16.12.15	MA	CP-14-053	EP-3-CS-053-005	10	00
2					DRAWN		JAGADISH		16.12.15				10	
3					DESIGNED									
4														

BHARAT HEAVY ELECTRICALS LIMITED
ELECTROPOWERCELLS DIVISION BANGALORE

TITLE :
POWER & CONTROL SCHEME
INCOMER-B CONTROLLED FROM DDCMIS ONLY



FIRST ANGLE PROJECTION

ALL DIMENSIONS ARE IN MM.

1

2

3

4

5

6

7

8

CUSTOMER:



TELANGANA STATE POWER GENERATION CORPORATION LTD
TELANGANA STATE
INDIA

PROJECT:

4x270 MW BHADRADRI THERMAL POWER STATION
MANUGURU

CUSTOMER CONSULTANT:

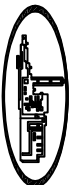

DESEIN PRIVATE LTD

COPYRIGHT AND CONFIDENTIAL

The information on the document is the property of BHARAT HEAVY ELECTRICALS LIMITED
It must not be used directly or indirectly in any way detrimental to the interest of the company

DRG. NO. EP-3-CS-053-006

INVENTORY NO.

REV. NO.	DATE	DESCRIPTION	BY	APPD.	APPROVED	NAME	SIGN.	DATE
1					CHECKED	TRINATH		16.12.15
2					DRAWN	JAGADISH		16.12.15
3					DESIGNED	JAGADISH		16.12.15
4								



BHARAT HEAVY ELECTRICALS LIMITED

ELECTROPROTECTANS DIVISION BANGALORE

TITLE :

POWER & CONTROL SCHEME
BUSCOUPLER CONTROLLED FROM DDCMIS ONLY

JOB NO. CP-14-053

DRG. NO. EP-3-CS-053-006



NO. OF SHEETS 08

SHEET NO. 01



REV. 00

DRG. NO. EP-3-CS-053-006

R31, NUMERICAL RELAY TYPE: REF615

1	2	3	4	5	6	7	8
FIRST ANGLE PROJECTION				ALL DIMENSIONS ARE IN MM.			

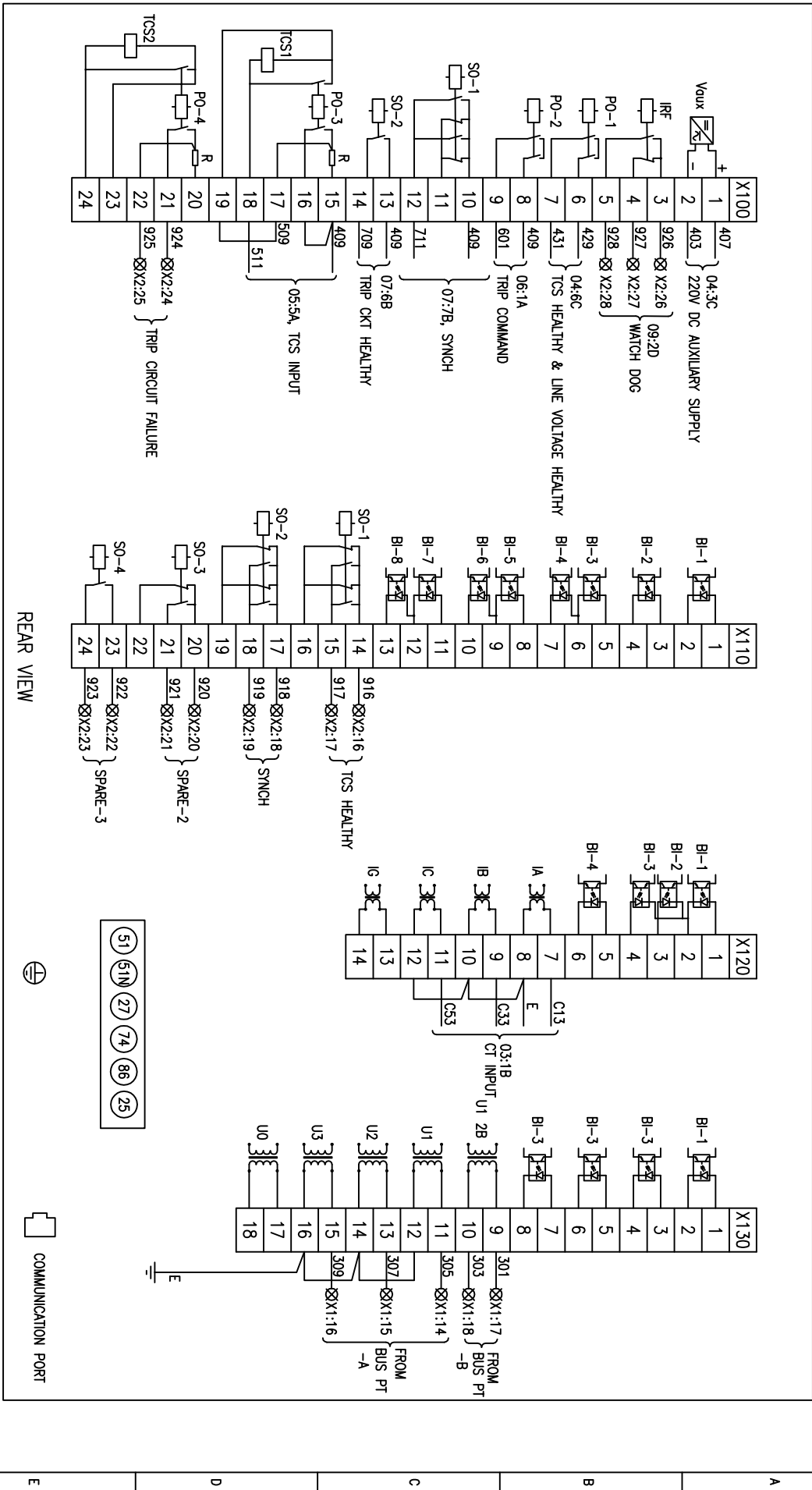

INVENTORY NO.	REV. NO.	DATE	DESCRIPTION	BY	APPD.	APPROVED	NAME	SIGN.	DATE	SCALE: NA	JOB NO. CP-14-053	DRG. NO. EP-3-CS-053-006	NO. OF SHEETS 08	SHEET NO. 03	REV. NO. 00
1	2					CHECKED	TRINATH		16.12.15						
3						DESIGNED	JAGADISH		16.12.15						
4						DRAWN									

BHARAT HEAVY ELECTRICALS LIMITED
ELECTROPROTECTIANS DIVISION BANGALORE

TITLE :
POWER & CONTROL SCHEME
BUSCOUPLER CONTROLLED FROM DCOMS ONLY



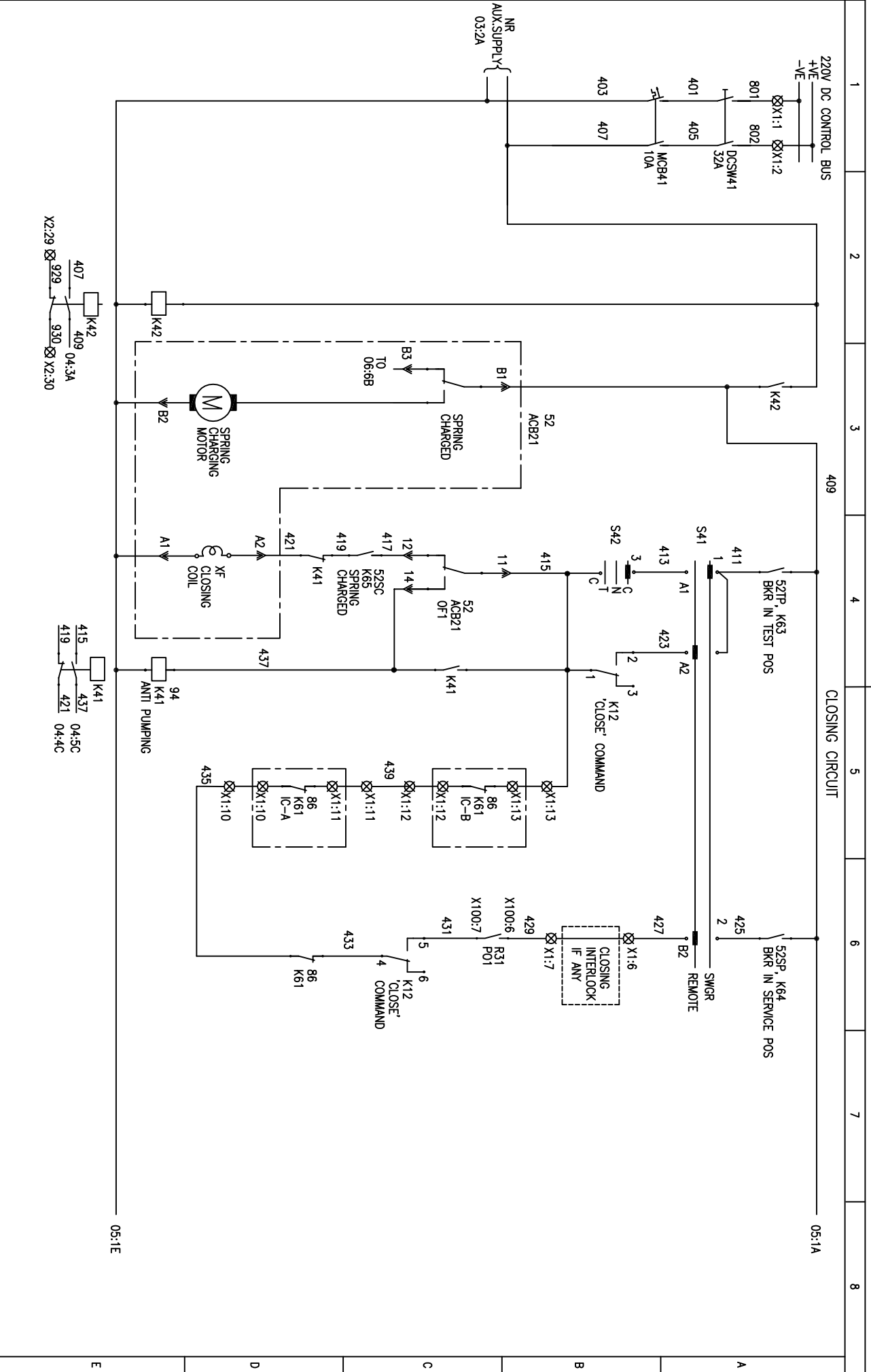

INVENTORY NO.	REV. NO.	DATE	DESCRIPTION	BY	APPD.	APPROVED	KSB	SCALE	JOB NO.	DRG. NO.	NO. OF SHEETS	SHEET NO.	REV.
	1							NA	CP-14-053	EP-3-CS-053-006	08	04	00
	2												
	3												
	4												

BHARAT HEAVY ELECTRICALS LIMITED
ELECTROPROTECTANS DIVISION BANGALORE

POWER & CONTROL SCHEME
BUSOUPLER CONTROLLED FROM DDCMS ONLY

TITLE :
JOB NO. CP-14-053

NO. OF SHEETS : 08
SHEET NO. : 04

FIRST ANGLE PROJECTION

ALL DIMENSIONS ARE IN MM.

8

DRG. NO. EP-3-CS-053-006

1	2	3	4	5	6	7	8
FIRST ANGLE PROJECTION				ALL DIMENSIONS ARE IN MM.			

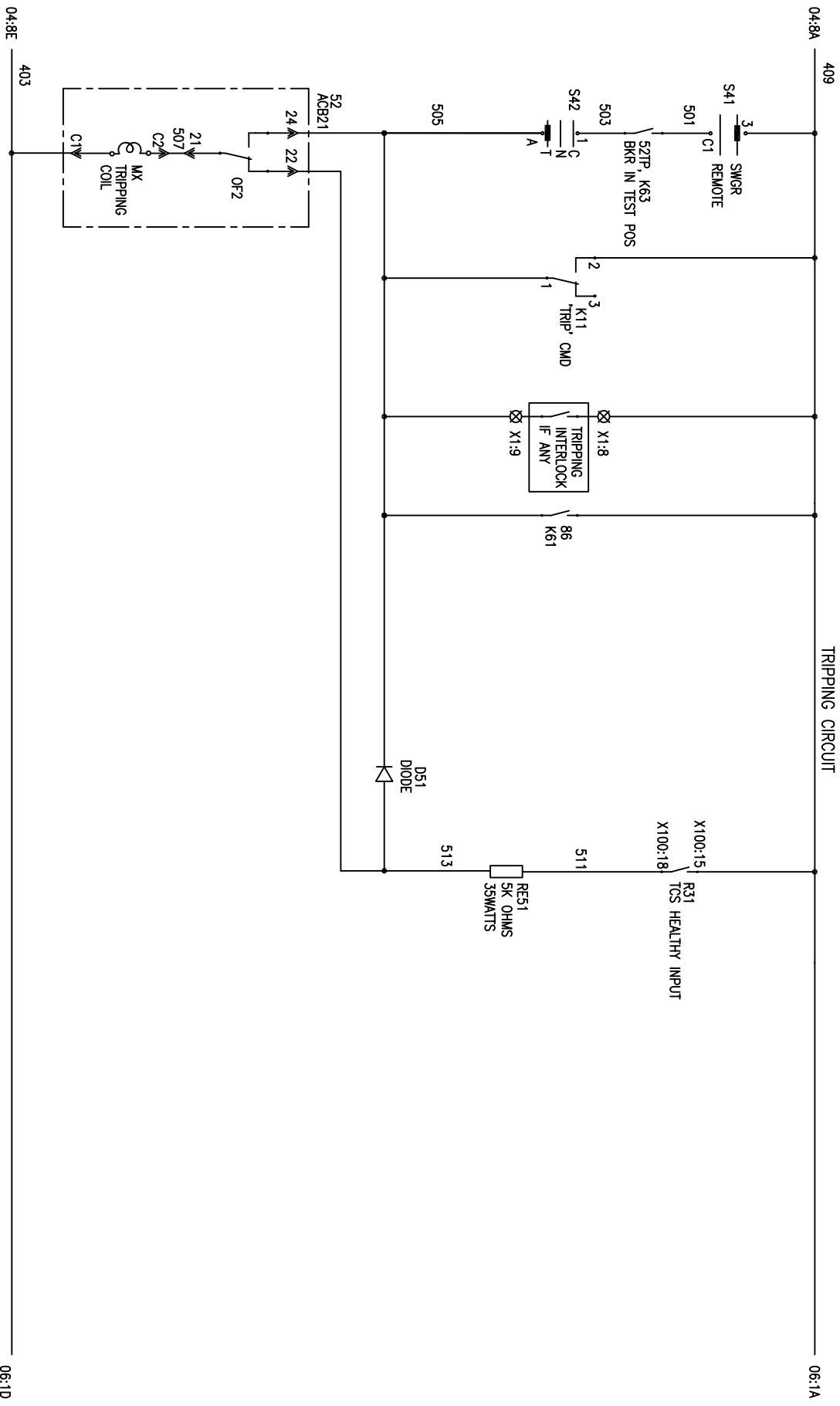

INVENTORY NO.	REV. NO.	DATE	DESCRIPTION	BY	APPD.	APPROVED	NAME	SIGN.	DATE	SCALE	JOB NO.	DRG. NO.	NO. OF SHEETS	NO. OF SHEETS	REV.
4	1										CP-14-053	EP-3-CS-053-006	08	05	00
3	2						JAGADISH		16.12.15						
2															
1							TRINATH		16.12.15						

BHARAT HEAVY ELECTRICALS LIMITED
ELECTROPOWERELANS DIVISION BANGALORE

POWER & CONTROL SCHEME
BUSCOUPLER CONTROLLED FROM DDCMS ONLY



DRG. NO. EP-3-CS-053-006

INVENTORY NO.

REV. NO.	DATE	DESCRIPTION	BY	APPD.	APPROVED	KSB	DATE	SCALE: NA	JOB NO. CP-14-053	DRG. NO. EP-3-CS-053-006	NO. OF SHEETS	NO. OF SHEETS	REV.
1					CHECKED	TRINATH	16.12.15				08	07	00
2					DRAWN		16.12.15						
3					DESIGNED	JAGADISH	16.12.15						
4													

FIRST ANGLE PROJECTION

ALL DIMENSIONS ARE IN MM

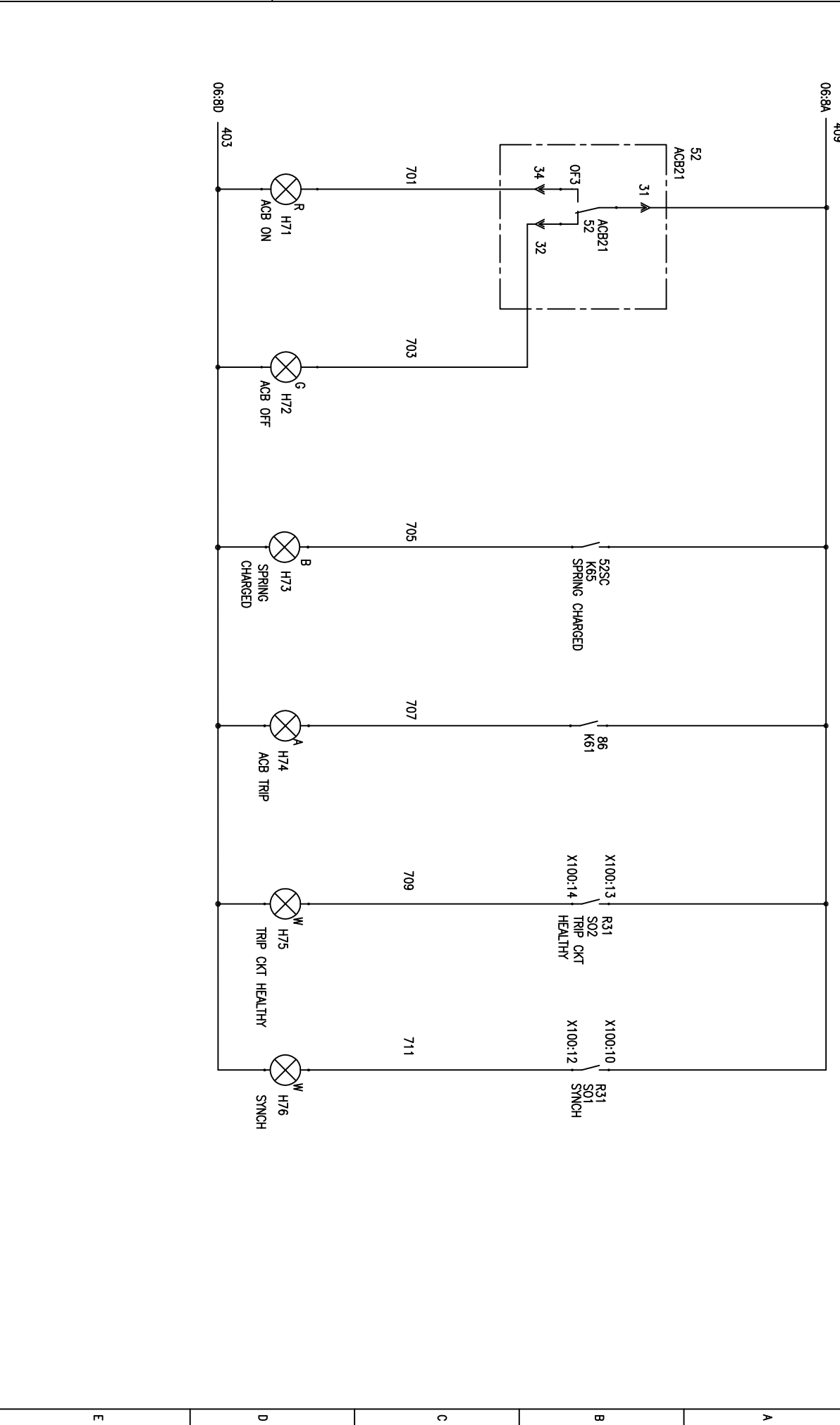

BHARAT HEAVY ELECTRICALS LIMITED
ELECTROPROTECTIANS DIVISION BANGALORE

POWER & CONTROL SCHEME
BUSCOUPLER CONTROLLED FROM DDCMIS ONLY



NO. OF SHEETS 08

SHEET NO. 07

REV. 00

DRG. NO. EP-3-CS-053-006

FORM 66-271 A3

INVENTORY NO.	4	DATE	BY	APPD.	APPROVED	NAME	SIGN.	DATE	SCALE	JOB NO.	DRG. NO.	NO. OF SHEETS	REV.
REV. NO.	1				CHECKED	TRINATH		16.12.15	NA	CP-14-053	EP-3-CS-053-006	08	08
	2				DRAWN								
	3				DESIGNED	JAGADISH		16.12.15					
	4												

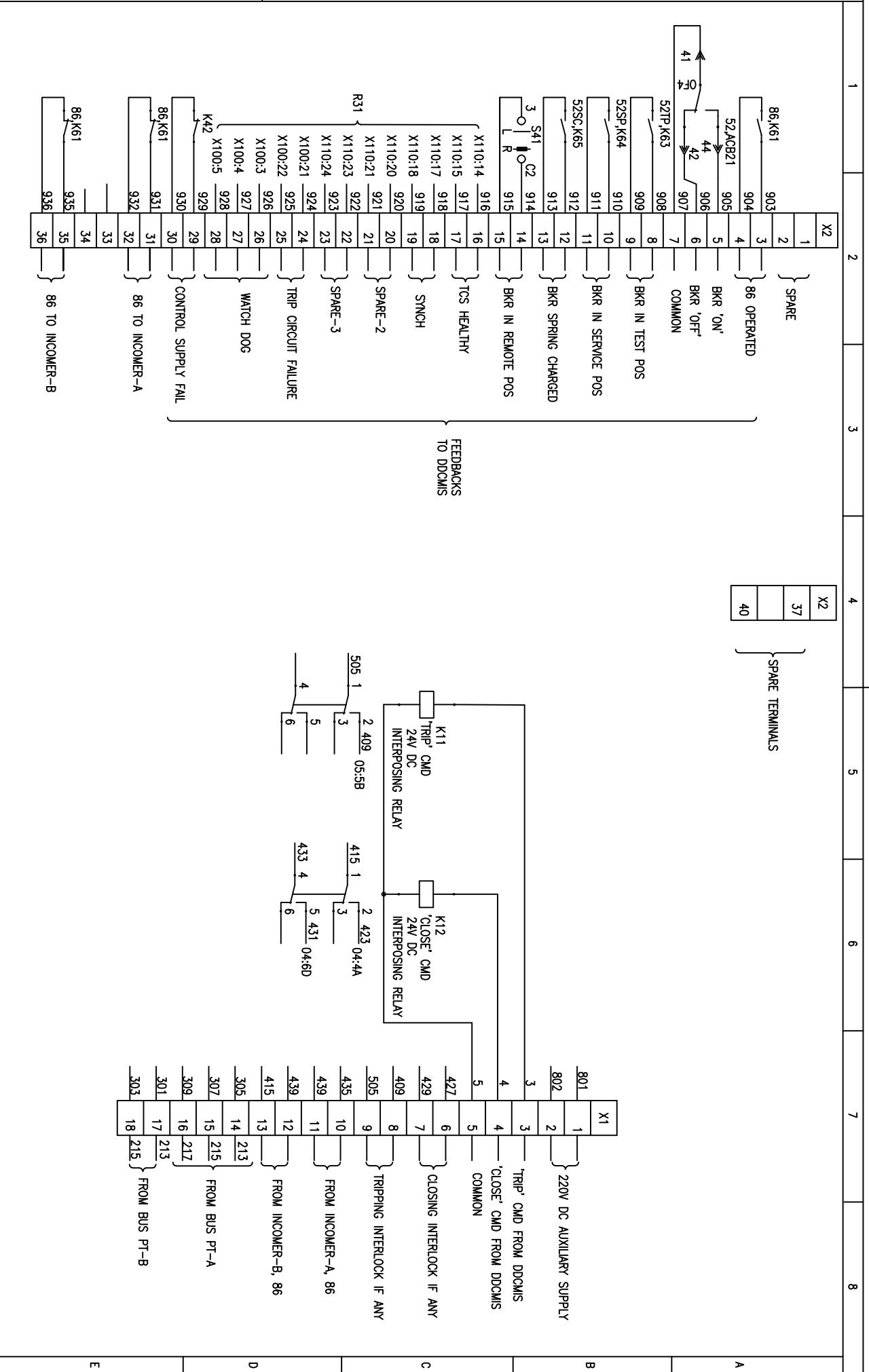

BHARAT HEAVY ELECTRICALS LIMITED
ELECTROPROTECTIANS DIVISION BANGALORE

TITLE :
POWER & CONTROL SCHEME
BUSCOUPLER CONTROLLED FROM DDCMIS ONLY



NO. OF SHEETS: 08
SHEET NO.: 08

REV. NO.: 00

FIRST ANGLE PROJECTION

ALL DIMENSIONS ARE IN MM.

1

2

3

4

5

6

7

8

CUSTOMER:



TELANGANA STATE POWER GENERATION CORPORATION LTD
TELANGANA STATE
INDIA

PROJECT:

4x270 MW BHADRADRI THERMAL POWER STATION
MANUGURU

CUSTOMER CONSULTANT:



DESEIN PRIVATE LTD

COPYRIGHT AND CONFIDENTIAL

The information on the document is the property of BHARAT HEAVY ELECTRICALS LIMITED
It must not be used directly or indirectly in any way detrimental to the interest of the company

DRG. NO. EP-3-CS-053-007

INVENTORY NO.

REV. NO.	DATE	DESCRIPTION	BY	APPD.	APPROVED	NAME	SIGN.	DATE
1					CHECKED	TRINATH		05.06.15
2					DRAWN	JAGADISH		05.06.15
3					DESIGNED	JAGADISH		05.06.15
4								



BHARAT HEAVY ELECTRICALS LIMITED
ELECTROFORCELANS DIVISION BANGALORE

TITLE :
POWER & CONTROL SCHEME
MAIN DG INCOMER CONTROLLED FROM ECP & DDCMIS

JOB NO. CP-14-053

DRG. NO. EP-3-CS-053-007



NO. OF SHEETS 10

SHEET NO. 01

REV. NO. 00

DRG. NO. EP-3-CS-053-007

FIRST ANGLE PROJECTION

ALL DIMENSIONS ARE IN MM.

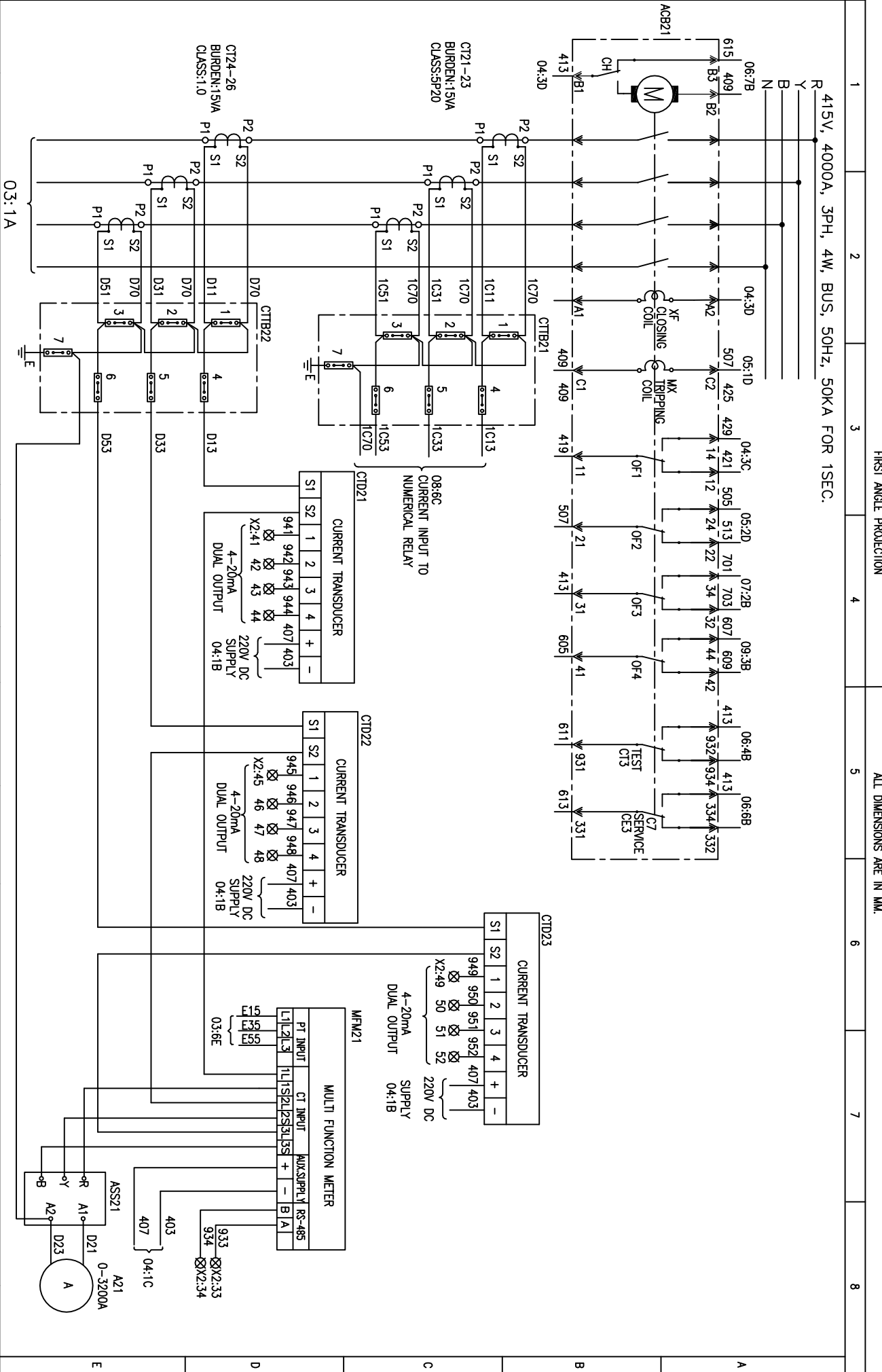

INVENTORY NO.	4	NAME	DESIGNED	DATE	SCALE	TITLE	NO. OF SHEETS
REV. NO.	1	CHECKED	TRINATH	05.06.15	MA	POWER & CONTROL SCHEME	10
DATE		BY	KSB	05.06.15	JOB NO.	CP-14-053	SHEET NO.
		APPD.			DRG. NO.	EP-3-CS-053-007	REV.
		APPROVED					00

DRG. NO. EP-3-CS-053-007

INVENTORY NO.

REV. NO.	DATE	DESCRIPTION	BY	APPD.	APPROVED	KSB	SCALE: NA	JOB NO. CP-14-053	DRG. NO. EP-3-CS-053-007	REV. NO.
1										03
2										
3										10
4										

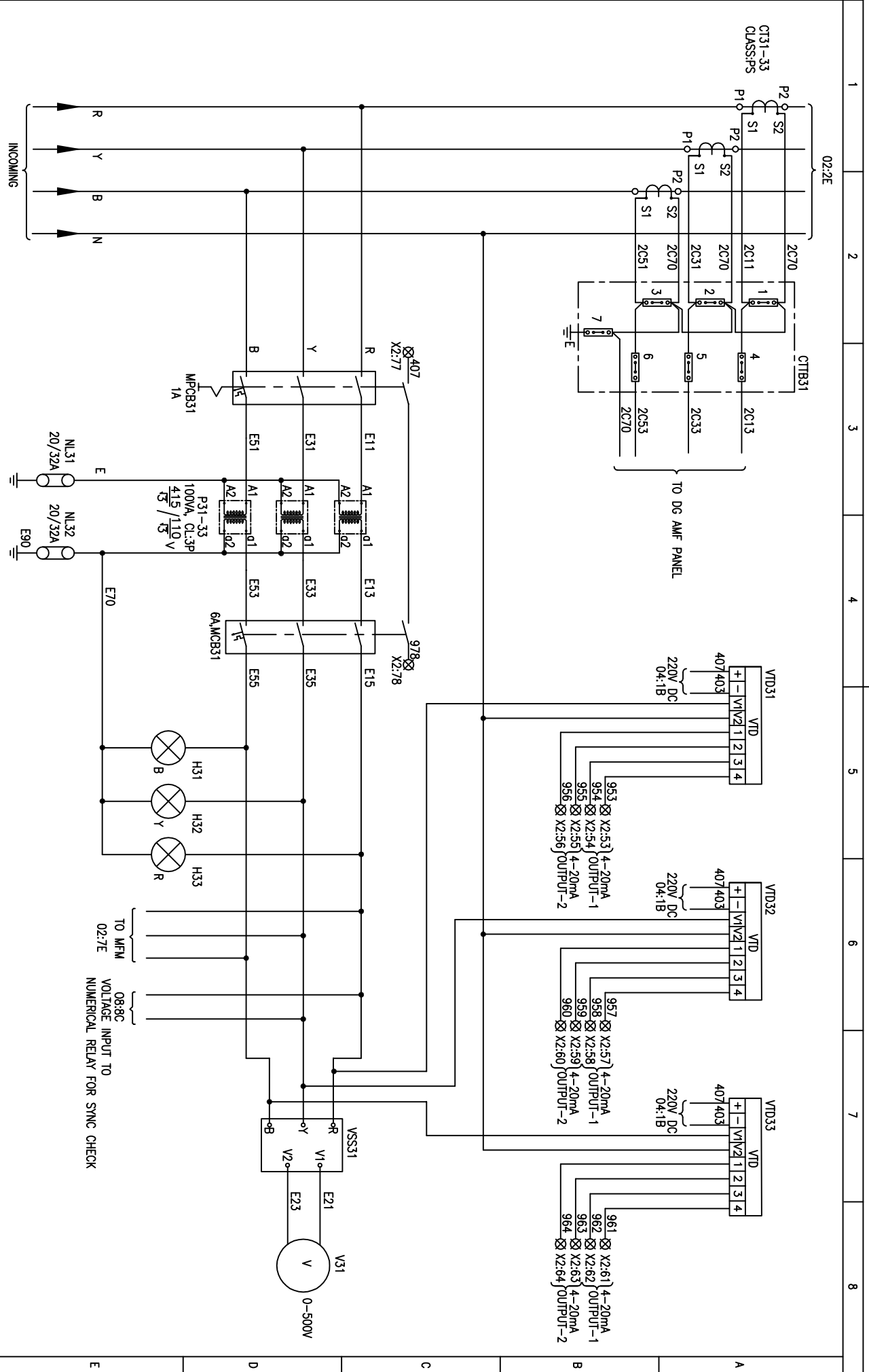

FIRST ANGLE PROJECTION

ALL DIMENSIONS ARE IN MM.

BHARAT HEAVY ELECTRICALS LIMITED
ELECTROPROTECTIANS DIVISION BANGALORE

TITLE :
POWER & CONTROL SCHEME
MAIN DG INCOMER CONTROLLED FROM ECP & DDCMS

NO. OF SHEETS	10
SHEET NO.	03



DRG. NO. EP-3-CS-053-007

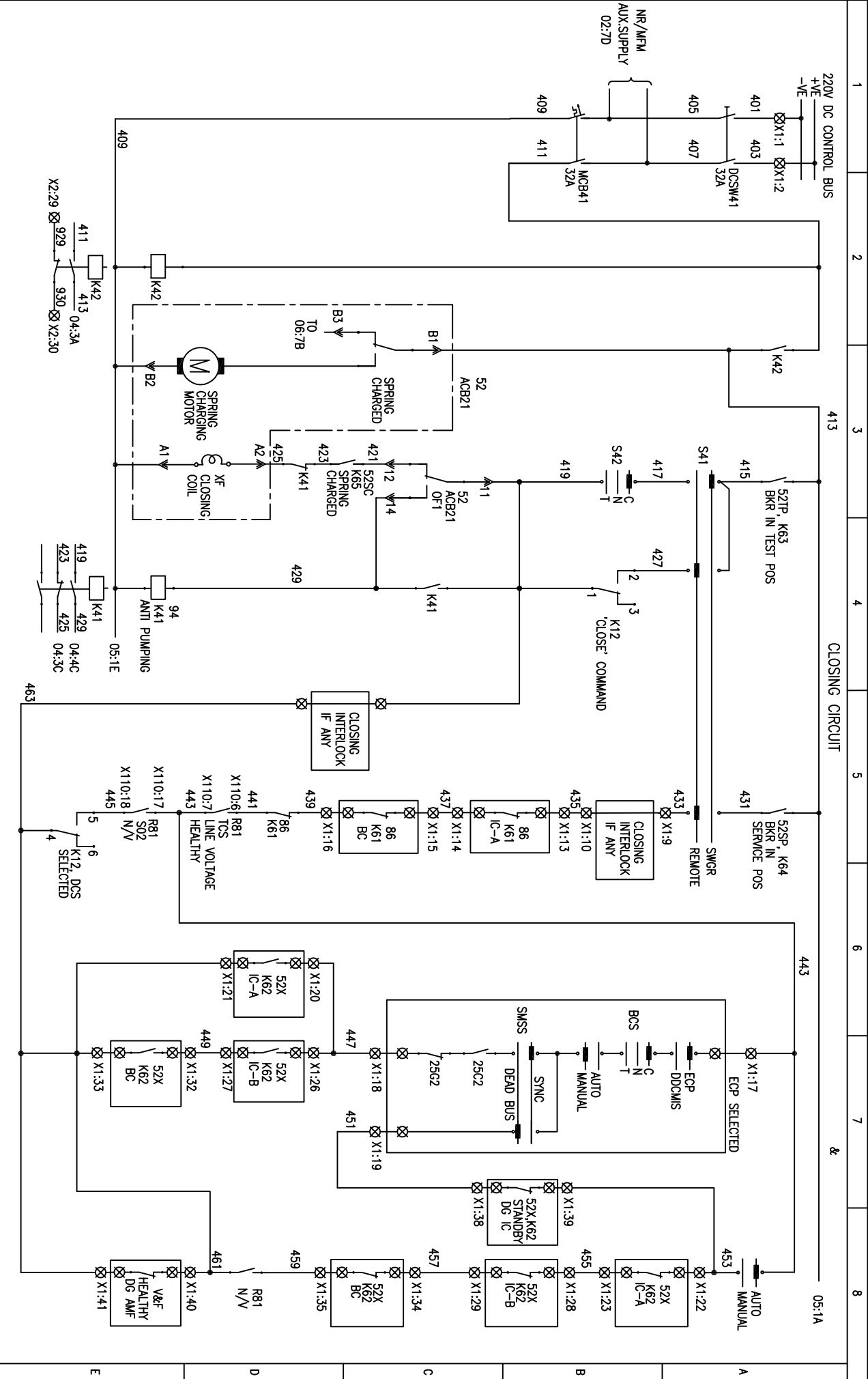

FIRST ANGLE PROJECTION

ALL DIMENSIONS ARE IN MM.

REV. NO.	DATE	DESCRIPTION	BY	APPD.	APPROVED	KSB	SCALE	JOB NO.	DRG. NO.
1							NA	CP-14-053	EP-3-CS-053-007
2									
3									
4									

INVENTORY NO.	NAME	SIGN.	DATE
1	TRINATH		05.06.15
2			
3	JAGADISH		05.06.15
4			

NO. OF SHEETS	SHEET NO.	REV.
10	04	00

BHARAT HEAVY ELECTRICALS LIMITED
 ELECTRONOPROCELAN'S DIVISION BANGALORE

TITLE :
POWER & CONTROL SCHEME
 MAIN DG INCOMER CONTROLLED FROM ECP & DDCMIS

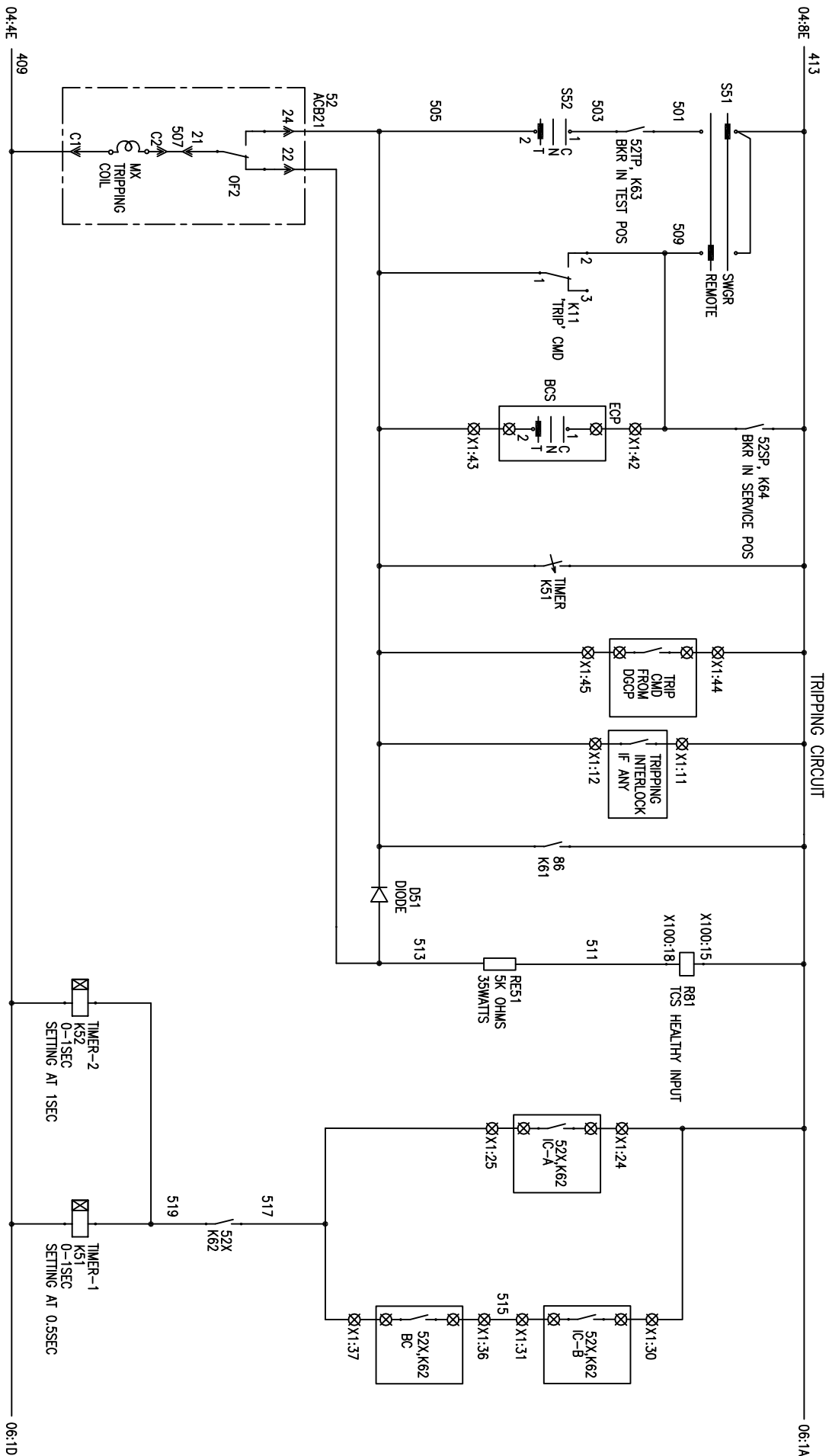

INVENTORY NO.		DRG. NO. EP-3-CS-053-007						
REV. NO.	DATE	DESCRIPTION	BY	APPD.	APPROVED	NAME	SIGN.	DATE
1					CHECKED	TRINATH		05.06.15
2					DRAWN	JAGADISH		05.06.15
3					DESIGNED	JAGADISH		05.06.15
4								
DESCRIPTION			BY	APPD.	APPROVED	NAME	SIGN.	DATE
BHARAT HEAVY ELECTRICALS LIMITED ELECTROPROTECTIANS DIVISION BANGALORE								
TITLE : POWER & CONTROL SCHEME MAIN DG INCOMER CONTROLLED FROM ECP & DDCMS			SCALE: NA	JOB NO. CP-14-053	DRG. NO. EP-3-CS-053-007	NO. OF SHEETS: 10 SHEET NO.: 05 REV. NO.: 00		

DRG. NO. EP-3-CS-053-007

FIRST ANGLE PROJECTION

ALL DIMENSIONS ARE IN MM.

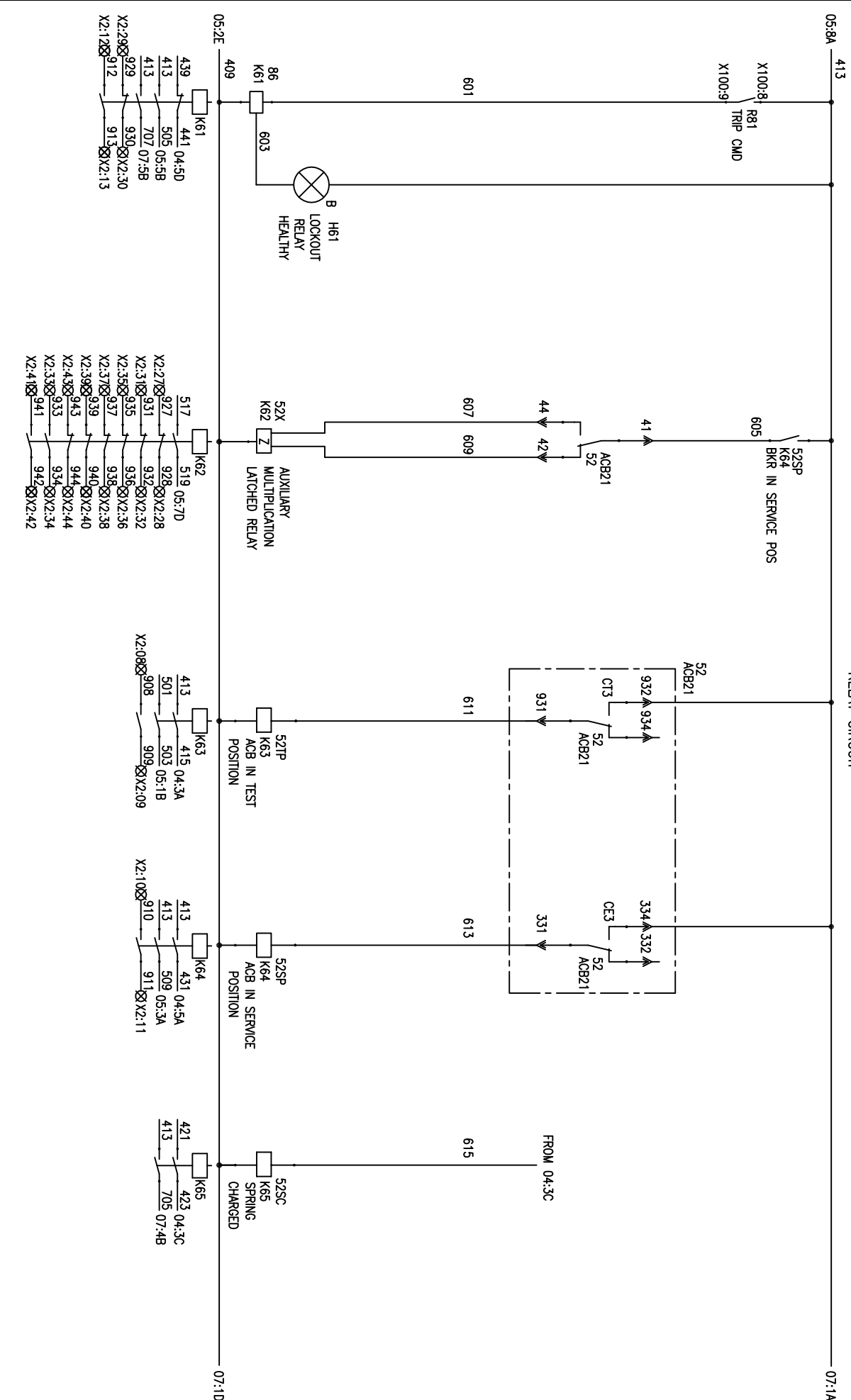

REV. NO.	DATE	DESCRIPTION	BY	APPD.	APPROVED	NAME	SIGN.	DATE	SCALE	JOB NO.	DRG. NO.	TITLE	NO. OF SHEETS	SHEET NO.	REV.
1						TRINATH		05.06.15	NA	CP-14-053	EP-3-CS-053-007	POWER & CONTROL SCHEME	10	06	00
2						JAGADISH		05.06.15							
3															
4															

DRG. NO. EP-3-CS-053-007

FIRST ANGLE PROJECTION

ALL DIMENSIONS ARE IN MM.

INDICATION CIRCUIT

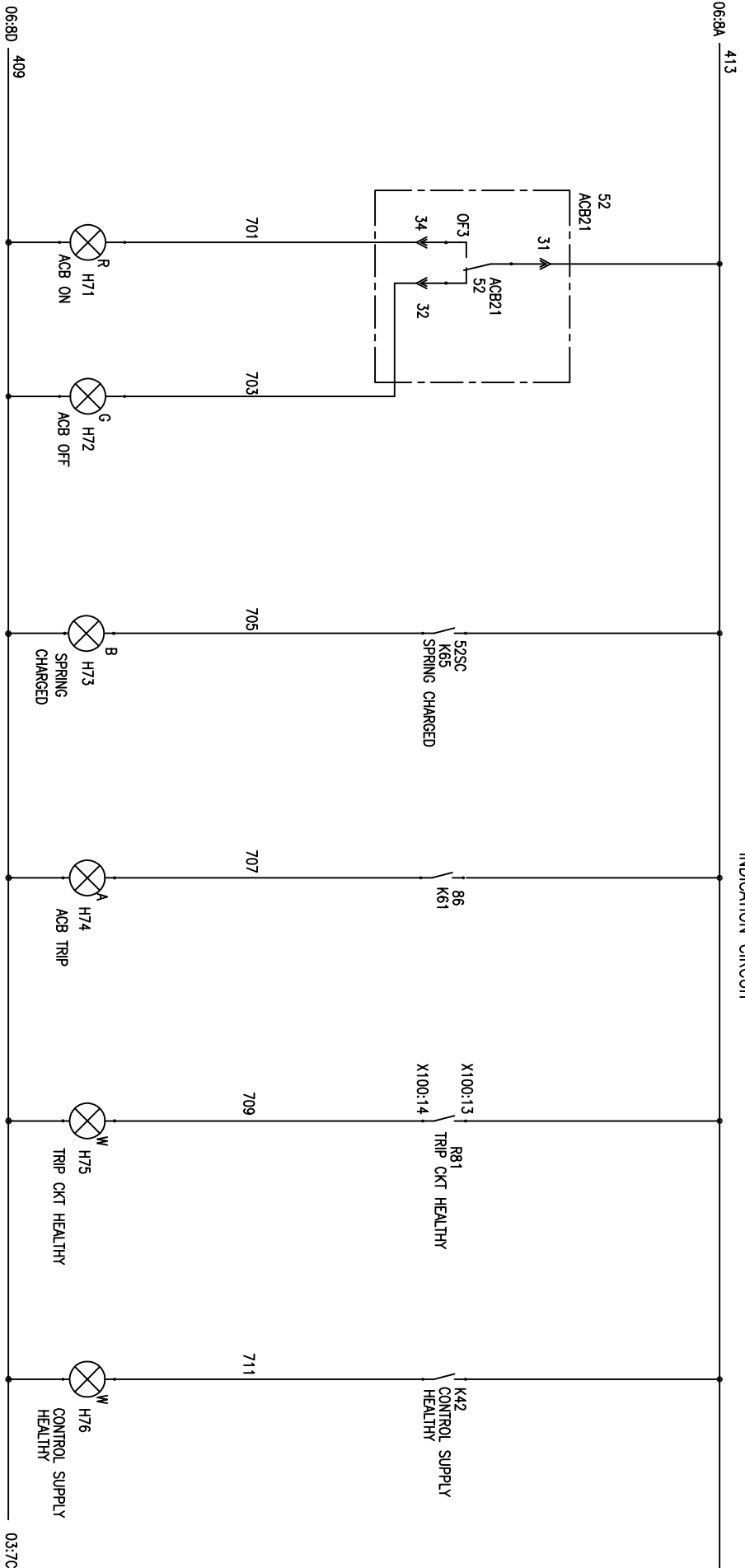

REV. NO.	DATE	DESCRIPTION	BY	APPD.	APPROVED	KSB	SCALE: NA	JOB NO. CP-14-053	DRG. NO. EP-3-CS-053-007	NO. OF SHEETS	SHEET NO.	REV.
1					CHECKED	TRINATH				10	07	00
2					DRAWN							
3					DESIGNED	JAGADISH						
4												



BHARAT HEAVY ELECTRICALS LIMITED
ELECTROPOWERCELLS DIVISION BANGALORE

TITLE :
POWER & CONTROL SCHEME
MAIN DG INCOMER CONTROLLED FROM ECP & DDCMS

DRG. NO. EP-3-CS-053-008

R81, NUMERICAL RELAY TYPE: REM615

1 2 3 4 5 6 7 8

FIRST ANGLE PROJECTION

ALL DIMENSIONS ARE IN MM

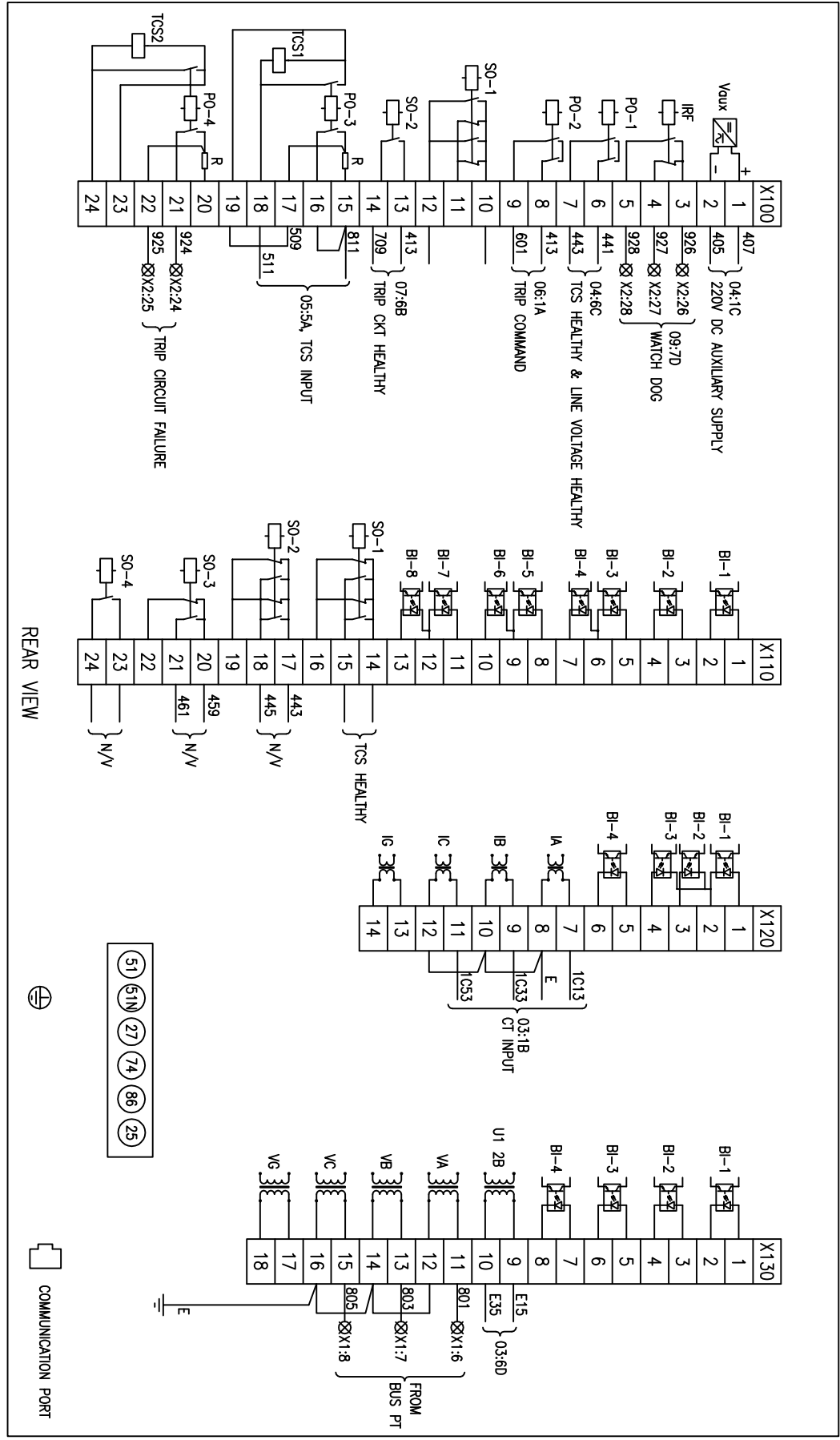

REV. NO.	DATE	DESCRIPTION	BY	APPD.	APPROVED	NAME	SIGN.	DATE	SCALE	JOB NO.	DRG. NO.	NO. OF SHEETS	SHEET NO.	REV.
1					CHECKED	TRINATH		05.06.15	MA	CP-14-053	EP-3-CS-053-008	10	08	00
2					DRAWN									
3					DESIGNED	JAGADISH		05.06.15						
4														

BHARAT HEAVY ELECTRICALS LIMITED
ELECTROPROTECTIANS DIVISION BANGALORE

TITLE :
POWER & CONTROL SCHEME
MAIN DG INCOMER CONTROLLED FROM ECP & DDCMS



DRG. NO. EP-3-CS-053-007

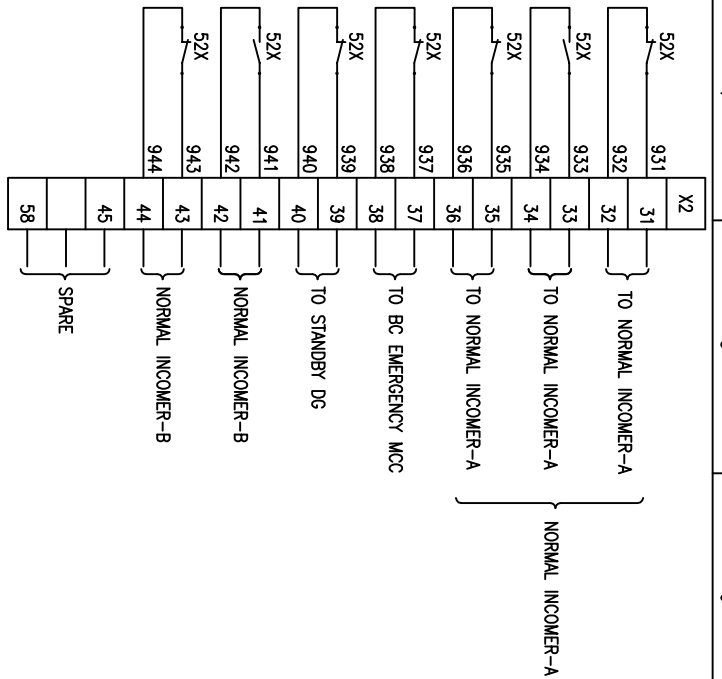
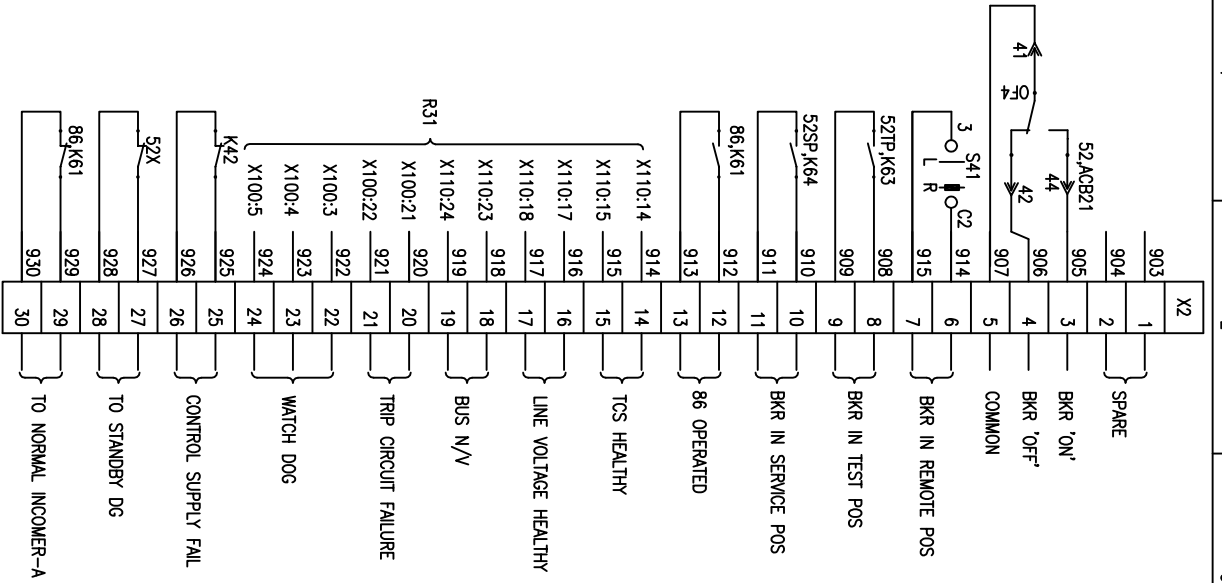

FIRST ANGLE PROJECTION

ALL DIMENSIONS ARE IN MM.

REV. NO.	DATE	DESCRIPTION	BY	APPD.	APPROVED	NAME	SIGN.	DATE	SCALE: NA	JOB NO. CP-14-053	DRG. NO. EP-3-CS-053-007	NO. OF SHEETS	SHEET NO.	REV.
1					CHECKED	TRINATH		05.06.15				10	09	00
2					DRAWN	JAGADISH		05.06.15						
3					DESIGNED	JAGADISH		05.06.15						
4														

BHARAT HEAVY ELECTRICALS LIMITED
ELECTROPROTECTIANS DIVISION BANGALORE

TITLE :
POWER & CONTROL SCHEME
MAIN DG INCOMER CONTROLLED FROM ECP & DDCMIS



FIRST ANGLE PROJECTION

ALL DIMENSIONS ARE IN MM.

1 2 3 4 5 6 7 8

CUSTOMER:



TELANGANA STATE POWER GENERATION CORPORATION LTD
TELANGANA STATE
INDIA

PROJECT:

4x270 MW BHADRADRI THERMAL POWER STATION
MANUGURU

CUSTOMER CONSULTANT:

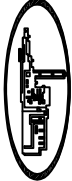

DESEIN PRIVATE LTD

DRG. NO. EP-3-CS-053-008

COPYRIGHT AND CONFIDENTIAL

The information on the document is the property of BHARAT HEAVY ELECTRICALS LIMITED
It must not be used directly or indirectly in any way detrimental to the interest of the company

REV. NO.	DATE	DESCRIPTION	BY	APPD.	APPROVED	NAME	SIGN.	DATE	SCALE: NA	JOB NO. CP-14-053	DRG. NO. EP-3-CS-053-008	NO. OF SHEETS	NO. OF SHEETS	REV.
4												10	01	00
3					DESIGNED	JAGADISH		05.06.15						
2					DRAWN									
1					CHECKED	TRINATH		05.06.15						

BHARAT HEAVY ELECTRICALS LIMITED
ELECTROPOWERCELLS DIVISION BANGALORE

TITLE :
POWER & CONTROL SCHEME
STANDBY DG INCOMER CONTROLLED FROM ECP & DDCMIS



DRG. NO. EP-3-CS-053-008

FIRST ANGLE PROJECTION

ALL DIMENSIONS ARE IN MM.

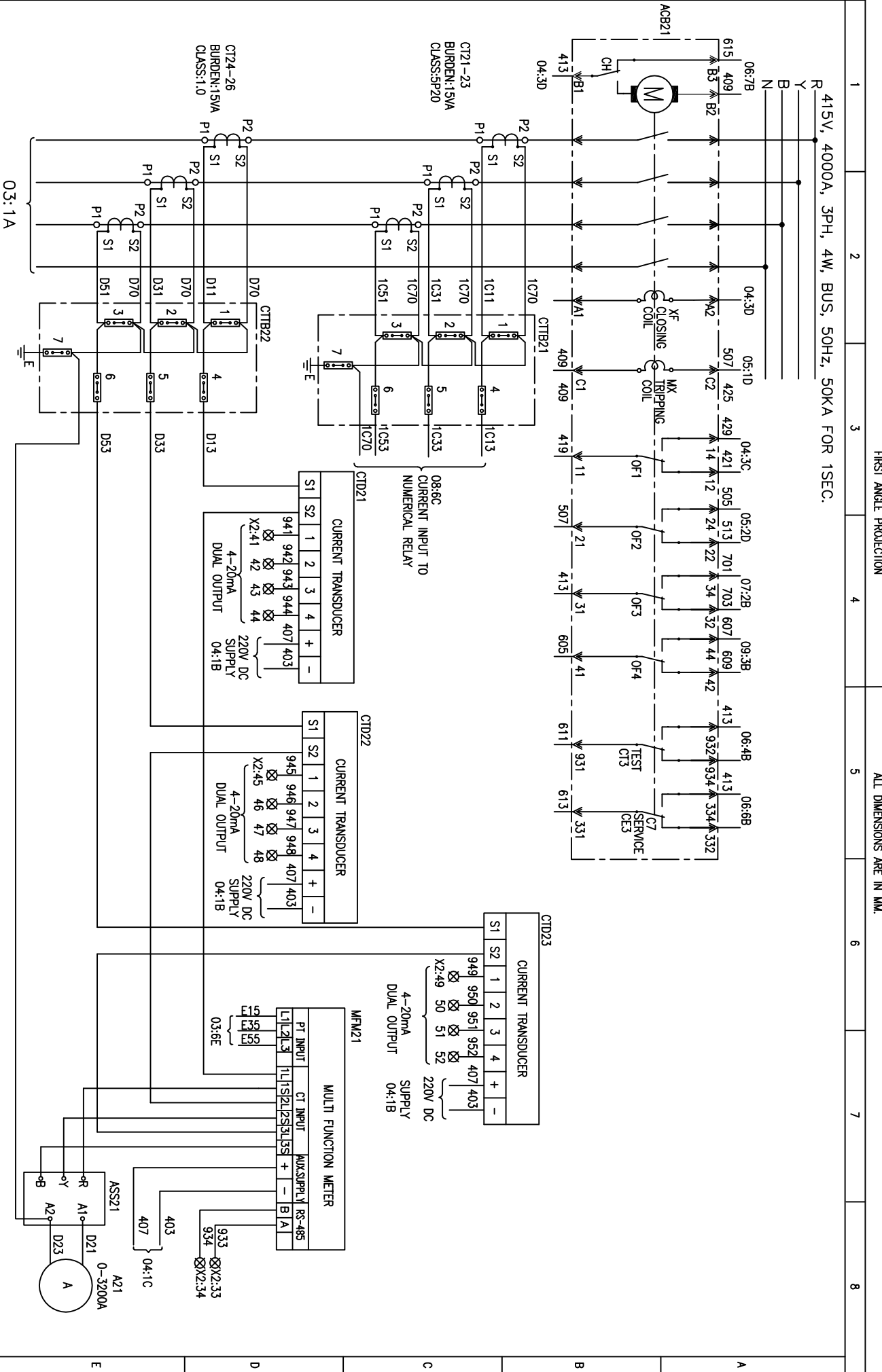

03:1A

INVENTORY NO.	4	NAME	DESIGNED	DATE	05.06.15	SCALE	NA	JOB NO.	CP-14-053	DRG. NO.	EP-3-CS-053-008
REV. NO.	1	DATE	DESCRIPTION	BY	APPD.	APPROVED	KSB	TITLE:	POWER & CONTROL SCHEME	NO. OF SHEETS	10
REV. NO.	2	DATE	DESCRIPTION	BY	APPD.	APPROVED	KSB	STANDBY DG INCOMER CONTROLLED FROM ECP & DDCMS		SHEET	02
REV. NO.	1	DATE	DESCRIPTION	BY	APPD.	APPROVED	KSB			REV.	00



BHARAT HEAVY ELECTRICALS LIMITED
 ELECTROPROTECTIANS DIVISION BANGALORE



DRG. NO. EP-3-CS-053-008

INVENTORY NO.	4	NAME		SIGN.		DATE		SCALE	NA	JOB NO.	CP-14-053	DRG. NO.	EP-3-CS-053-008
REV. NO.	1	BY		APPD.		CHECKED	TRINATH	05.06.15		TITLE :	BHARAT HEAVY ELECTRICALS LIMITED ELECTROPROTECTIANS DIVISION BANGALORE		
DATE		DESCRIPTION		APPROVED		DESIGNED	JAGADISH	05.06.15		POWER & CONTROL SCHEME			
	2					DRAWN				STANDBY DG INCOMER CONTROLLED FROM ECP & DDCMIS			
	3									NO. OF SHEETS	10	SHEET NO.	03
	4									REV.	00		

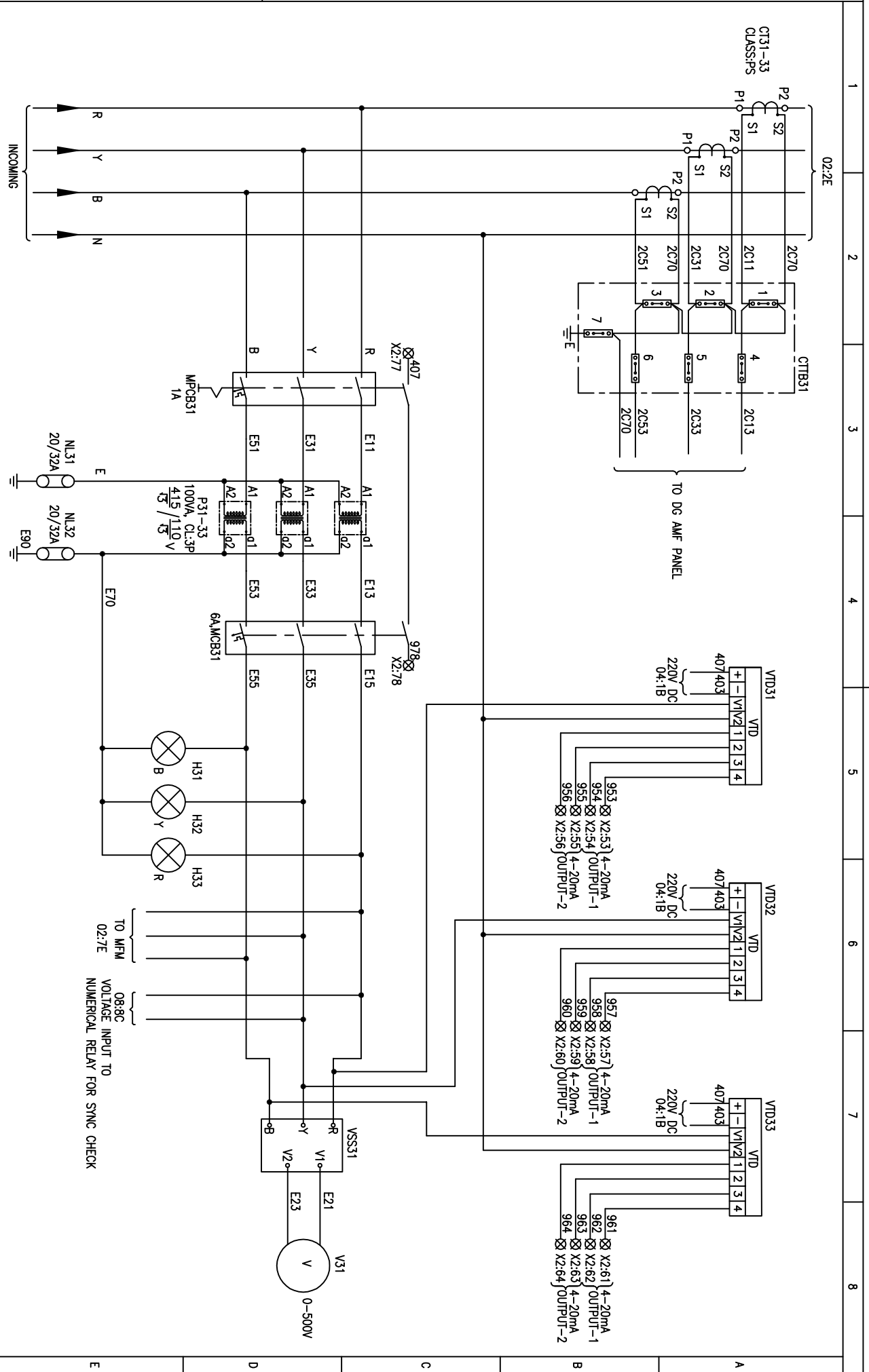

FIRST ANGLE PROJECTION

ALL DIMENSIONS ARE IN MM.

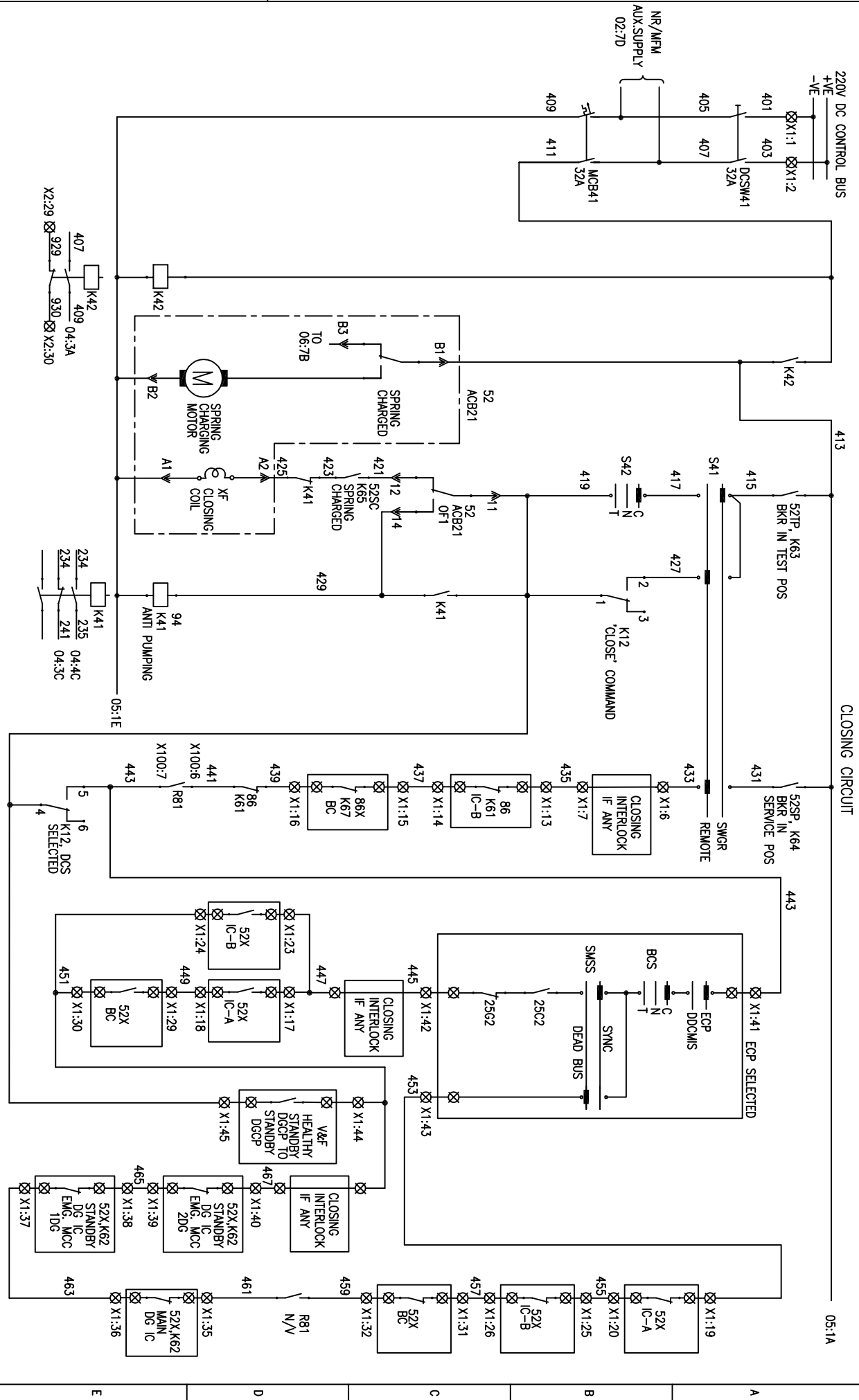

1 FIRST ANGLE PROJECTION
 2
 3
 4
 5 CLOSING CIRCUIT
 6 ALL DIMENSIONS ARE IN MM.
 7
 8

INVENTORY NO.	4	NAME	TRINATH	DATE	05.06.15
REV. NO.	1	DESIGNED	JAGADISH	DATE	05.06.15
DATE		DRAWN		CHECKED	05.06.15
				APPROVED	
		BY	KSB	SCALE	NA
		APPD.		TITLE	POWER & CONTROL SCHEME
				JOB NO.	CP-14-053
				DRG. NO.	EP-3-CS-053-008
				NO. OF SHEETS	10
				SHEET NO.	04
				REV.	00



BHARAT HEAVY ELECTRICALS LIMITED
 ELECTROPOWERTECHNICALS DIVISION BANGALORE

REV. NO.	DATE	DESCRIPTION	BY	APPD.	APPROVED	KSB	SCALE: NA	JOB NO. CP-14-053	DRG. NO. EP-3-CS-053-008	NO. OF SHEETS	SHEET NO.	REV.
1					CHECKED	TRINATH	05.06.15			10	05	00
2					DRAWN							
3					DESIGNED	JAGADISH	05.06.15					
4												

BHARAT HEAVY ELECTRICALS LIMITED
ELECTROFORCELANS DIVISION BANGALORE

POWER & CONTROL SCHEME
STANDBY DG INCOMER CONTROLLED FROM ECP & DCOMIS

NO. OF SHEETS: 10
SHEET NO.: 05
REV.: 00

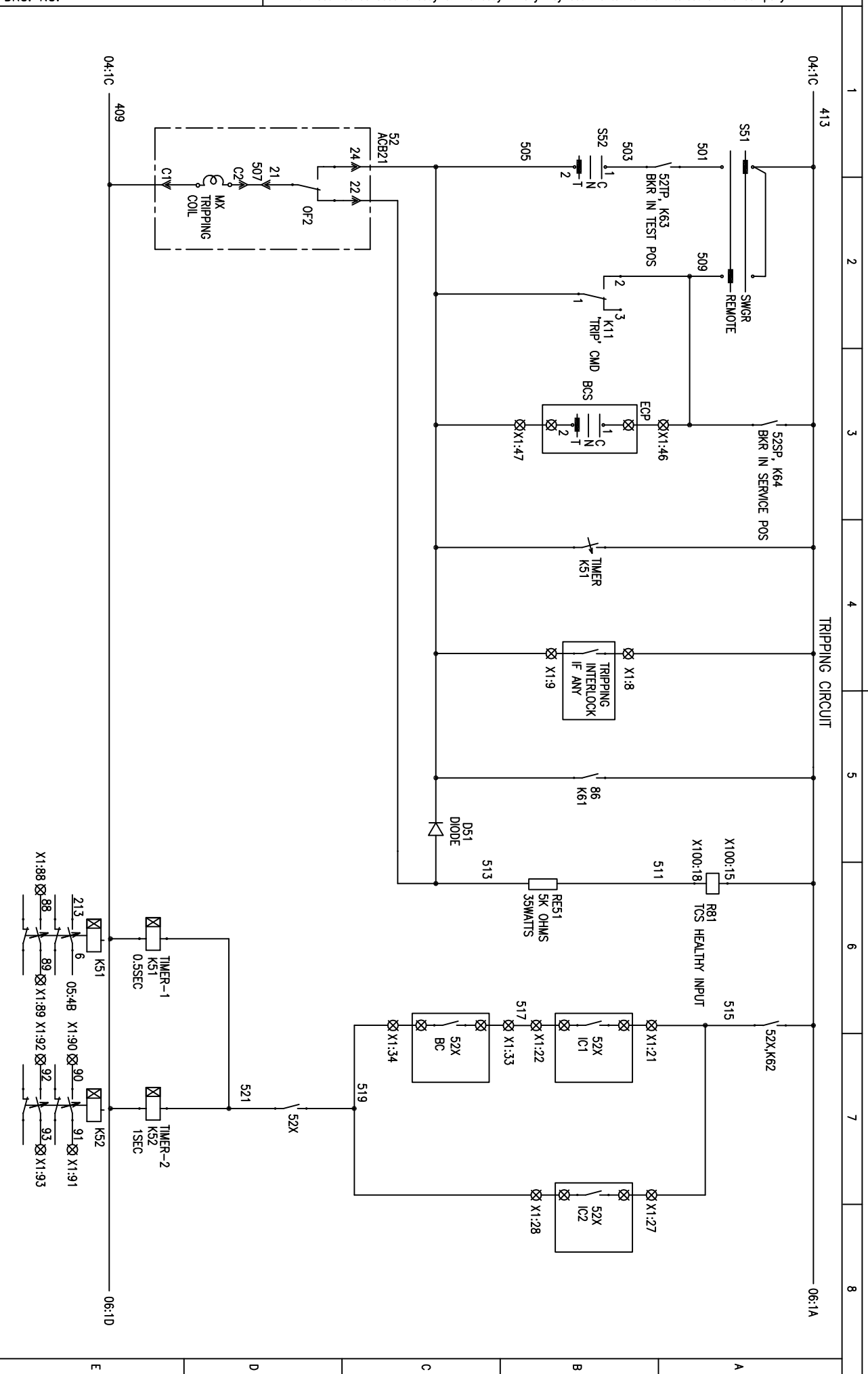

DRG. NO. EP-3-CS-053-008

INVENTORY NO.

REV. NO.	DATE	DESCRIPTION	BY	APPD.	APPROVED	NAME	SIGN.	DATE	SCALE	JOB NO.	DRG. NO.	NO. OF SHEETS	SHEET NO.	REV.
1					CHECKED	TRINATH		05.06.15	MA	CP-14-053	EP-3-CS-053-008	10	07	00
2					DRAWN	JAGADISH		05.06.15						
3					DESIGNED	JAGADISH		05.06.15						
4														

FIRST ANGLE PROJECTION

ALL DIMENSIONS ARE IN MM.

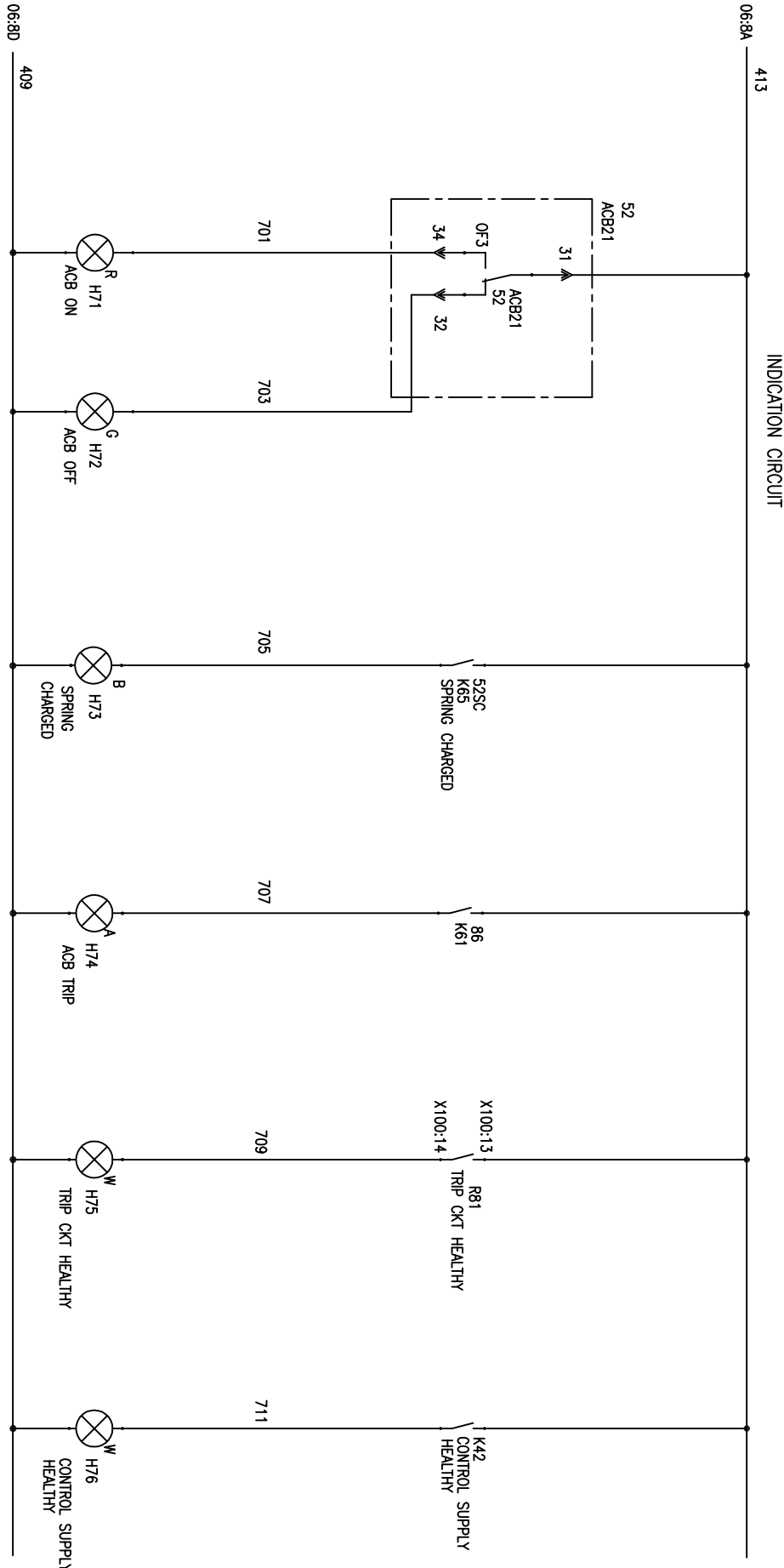

A
B
C
D
E

BHARAT HEAVY ELECTRICALS LIMITED
ELECTROPOWERCELLS DIVISION BANGALORE

TITLE :
POWER & CONTROL SCHEME
STANDBY DG INCOMER CONTROLLED FROM ECP & DDCMS



NO. OF SHEETS 10

SHEET NO. 07

REV. 00

DRG. NO. EP-3-CS-053-008

R81, NUMERICAL RELAY TYPE: REM615

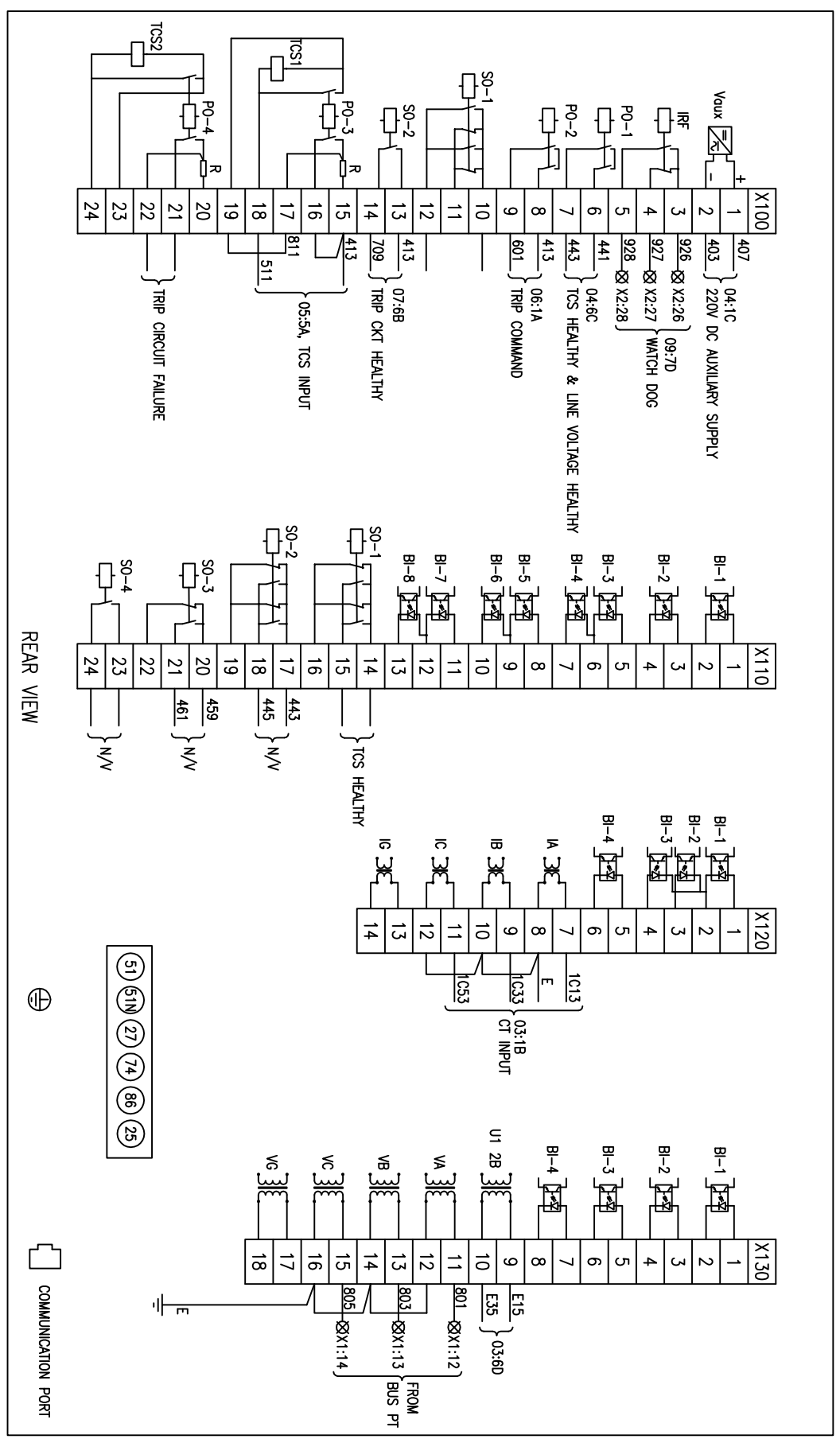

REAR VIEW

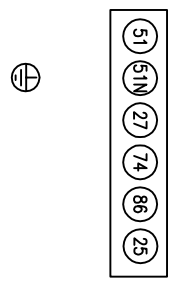

REV. NO.	DATE	DESCRIPTION	BY	APPD.	APPROVED	KSB	SCALE: NA	JOB NO. CP-14-053	DRG. NO. EP-3-CS-053-008	NO. OF SHEETS	SHEET NO.	REV.
1					CHECKED	TRINATH	05.06.15			10	08	
2					DRAWN							
3					DESIGNED	JAGADISH	05.06.15					
4												

BHARAT HEAVY ELECTRICALS LIMITED
ELECTROPROTECTIANS DIVISION BANGALORE

TITLE :
POWER & CONTROL SCHEME
STANDBY DG INCOMER CONTROLLED FROM ECP & DDGMS



FIRST ANGLE PROJECTION
ALL DIMENSIONS ARE IN MM

DRG. NO. EP-3-CS-053-007

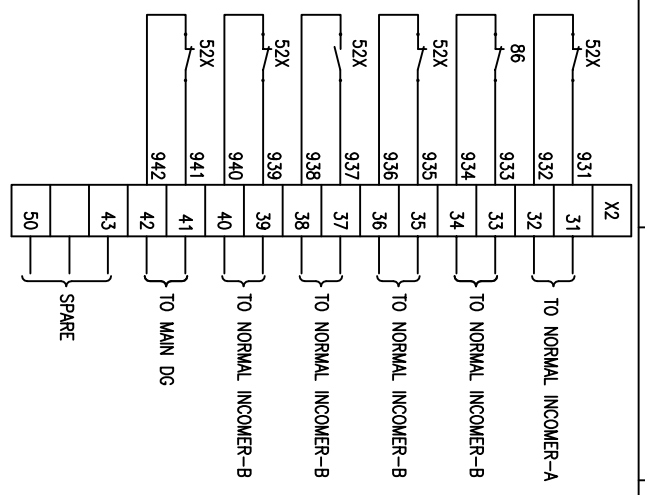
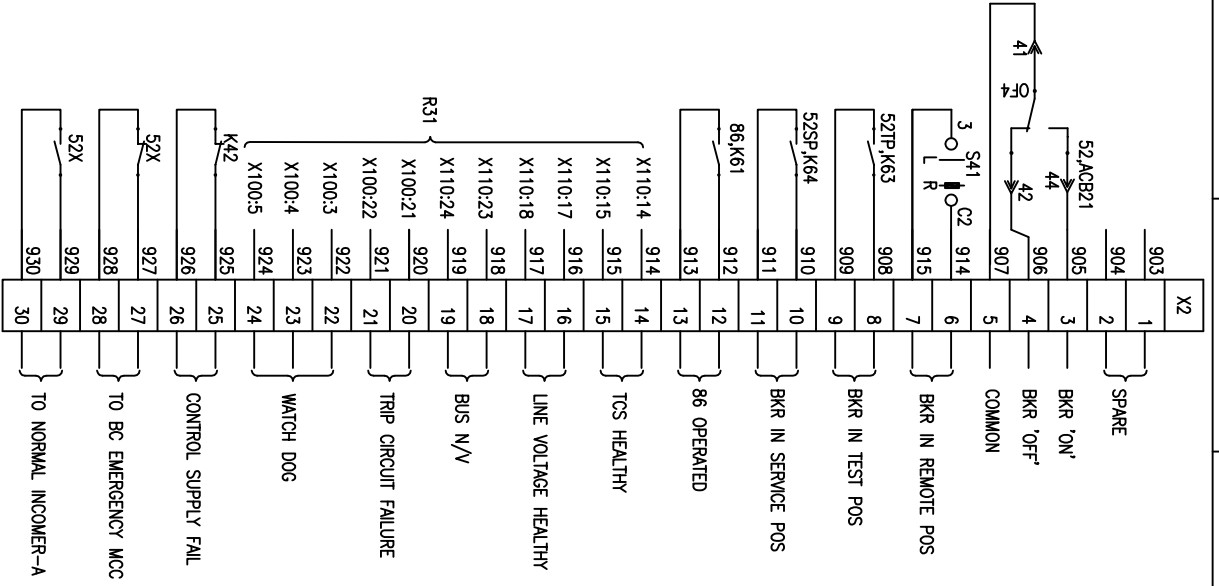

FIRST ANGLE PROJECTION

ALL DIMENSIONS ARE IN MM

INVENTORY NO.	REV. NO.	DATE	DESCRIPTION	BY	APPD.	APPROVED	NAME	SIGN.	DATE	SCALE: NA	JOB NO. CP-14-053	DRG. NO. EP-3-CS-053-008	NO. OF SHEETS	SHEET NO.	REV.
4													10	09	00
3						DESIGNED	JAGADISH		05.06.15						
2						DRAWN									
1						CHECKED	TRINATH		05.06.15						

BHARAT HEAVY ELECTRICALS LIMITED
ELECTROPROTECTIANS DIVISION BANGALORE

TITLE :
POWER & CONTROL SCHEME
MAIN DG INCOMER CONTROLLED FROM ECP & DDCMIS



DRG. NO. EP-3-CS-053-008

FORM 66-271 A3

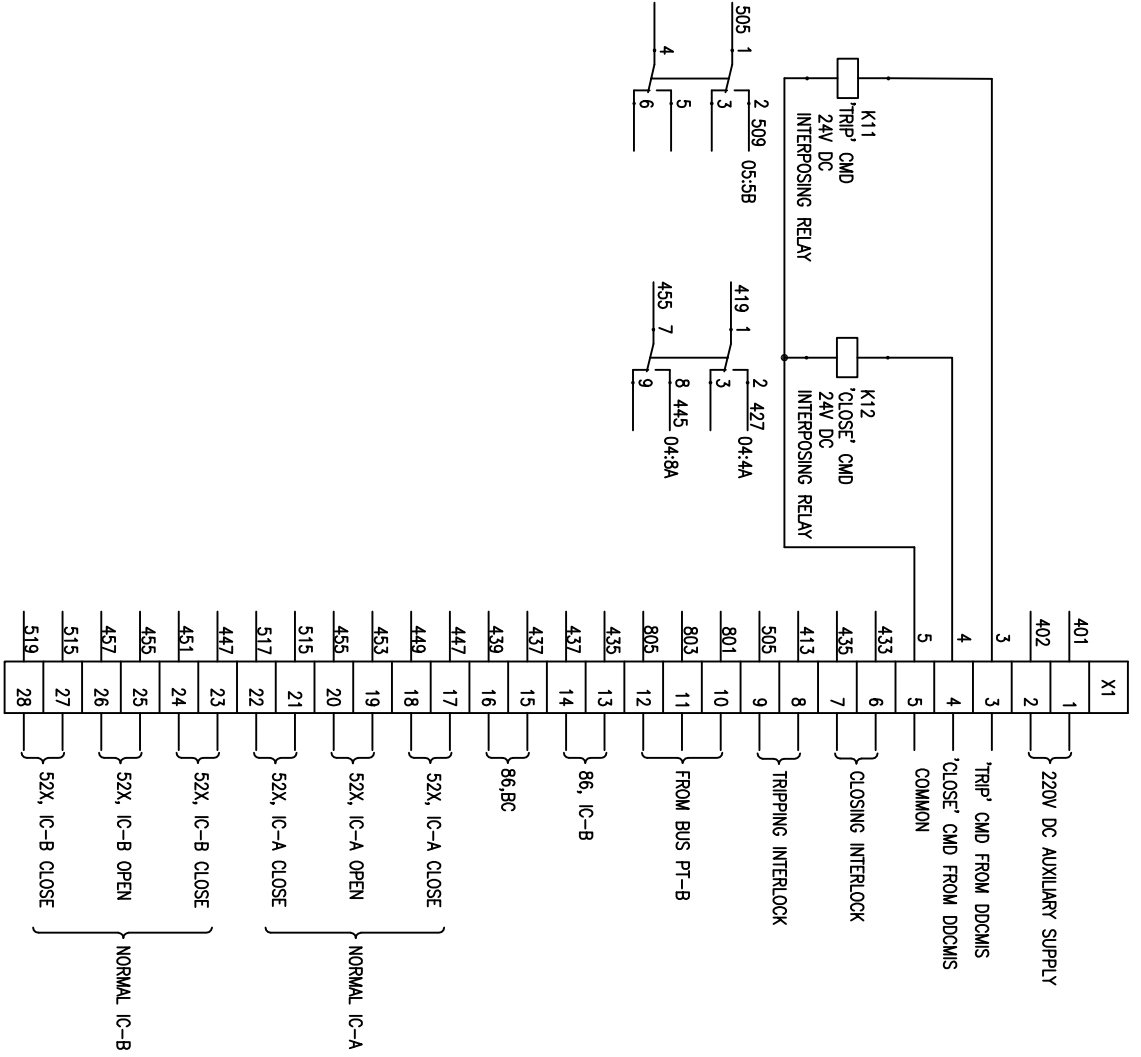

Terminal	Description	Terminal	Description
X1 1	220V DC AUXILIARY SUPPLY	X1 29	52X, BC CLOSE
X1 2	TRIP CMD FROM DDCMIS	X1 30	52X, BC OPEN
X1 3	TRIP CMD FROM DDCMIS	X1 31	52X, BC OPEN
X1 4	CLOSE CMD FROM DDCMIS	X1 32	52X, BC OPEN
X1 5	COMMON	X1 33	52X, BC CLOSE
X1 6	CLOSING INTERLOCK	X1 34	52X, BC CLOSE
X1 7	CLOSING INTERLOCK	X1 35	52X, MAIN DG IC
X1 8	TRIPPING INTERLOCK	X1 36	52X, MAIN DG IC
X1 9	TRIPPING INTERLOCK	X1 37	52X, 1DG OPEN
X1 10	FROM BUS PT-B	X1 38	52X, 1DG OPEN
X1 11	FROM BUS PT-B	X1 39	52X, 2DG OPEN
X1 12	FROM BUS PT-B	X1 40	52X, 2DG OPEN
X1 13	86, IC-B	X1 41	ECP COMMAND
X1 14	86, IC-B	X1 42	ECP COMMAND
X1 15	86, BC	X1 43	ECP COMMAND
X1 16	86, BC	X1 44	V & F HEALTHY, DG AMF
X1 17	52X, IC-A CLOSE	X1 45	V & F HEALTHY, DG AMF
X1 18	52X, IC-A CLOSE	X1 46	ECP TRIP
X1 19	52X, IC-A OPEN	X1 47	ECP TRIP
X1 20	52X, IC-A OPEN	X1 48	ECP TRIP
X1 21	52X, IC-A CLOSE	X1 49	SPARE
X1 22	52X, IC-A CLOSE	X1 50	SPARE
X1 23	52X, IC-B CLOSE	X1 51	SPARE
X1 24	52X, IC-B CLOSE	X1 52	SPARE
X1 25	52X, IC-B OPEN	X1 53	SPARE
X1 26	52X, IC-B OPEN	X1 54	SPARE
X1 27	52X, IC-B CLOSE	X1 55	SPARE
X1 28	52X, IC-B CLOSE	X1 56	SPARE

REV. NO.	DATE	DESCRIPTION	BY	APPD.	APPROVED	NAME	SIGN.	DATE
1					CHECKED	TRINATH		05.06.15
2					DRAWN			
3					DESIGNED	JAGADISH		05.06.15
4								

BHARAT HEAVY ELECTRICALS LIMITED
ELECTRONECELEANS DIVISION BANGALORE

TITLE :
POWER & CONTROL SCHEME
STANDBY DG INCOMER CONTROLLED FROM ECP & DDCMIS

JOB NO. CP-14-053 DRG. NO. EP-3-CS-053-008

NO. OF SHEETS: 10
SHEET NO.: 10
REV.: 00

FIRST ANGLE PROJECTION ALL DIMENSIONS ARE IN MM

FIRST ANGLE PROJECTION

ALL DIMENSIONS ARE IN MM.

1

2

3

4

5

6

7

8

CUSTOMER:



TELANGANA STATE POWER GENERATION CORPORATION LTD
TELANGANA STATE
INDIA

PROJECT:

4x270 MW BHADRADRI THERMAL POWER STATION
MANUGURU

CUSTOMER CONSULTANT:

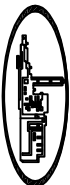

DESEIN PRIVATE LTD

COPYRIGHT AND CONFIDENTIAL

The information on the document is the property of BHARAT HEAVY ELECTRICALS LIMITED
It must not be used directly or indirectly in any way detrimental to the interest of the company

DRG. NO. EP-3-CS-053-009

INVENTORY NO.

REV. NO.	DATE	DESCRIPTION	BY	APPD.	APPROVED	NAME	SIGN.	DATE
1					CHECKED	TRINATH		05.06.15
2					DRAWN	JAGADISH		05.06.15
3					DESIGNED	JAGADISH		05.06.15
4								



BHARAT HEAVY ELECTRICALS LIMITED

ELECTROPOWERCELLS DIVISION BANGALORE

TITLE :

POWER & CONTROL SCHEME
NORMAL DG INCOMER-A

JOB NO. CP-14-053

DRG. NO. EP-3-CS-053-009



NO. OF SHEETS 10

SHEET NO. 01



REV. 00

DRG. NO. EP-3-CS-053-009

FIRST ANGLE PROJECTION

ALL DIMENSIONS ARE IN MM.

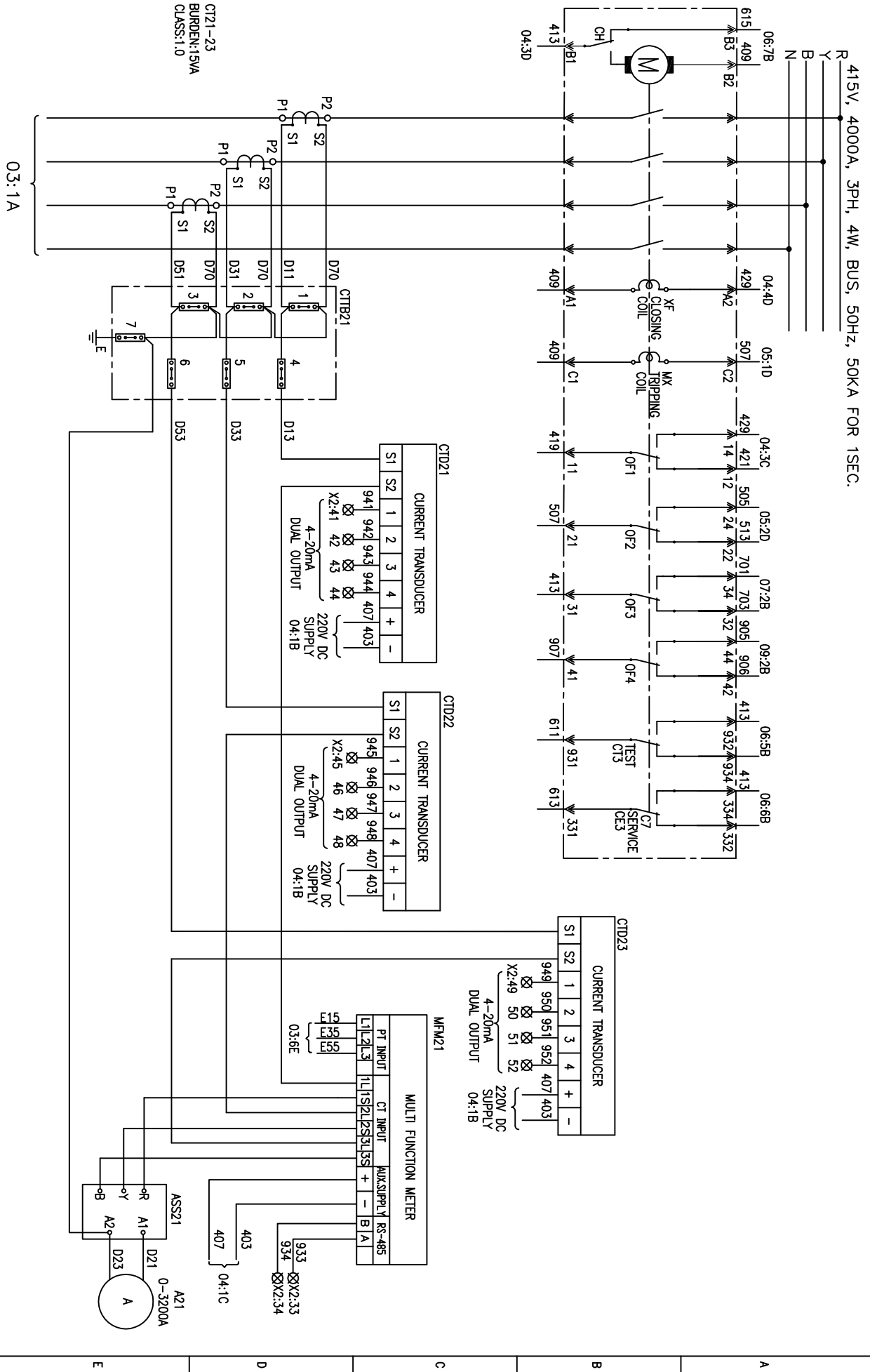

CT21-23
BURDEN:15VA
CLASS:1.0

03:1A

CTD21		CTD22	
S1	S2	S1	S2
941	942	945	946
943	944	947	948
407	403	407	403
+	-	+	-
4-20ma DUAL OUTPUT		4-20ma DUAL OUTPUT	
220V DC SUPPLY 04:1B		220V DC SUPPLY 04:1B	

CTD23	
S1	S2
949	950
951	952
407	403
+	-
4-20ma DUAL OUTPUT	
220V DC SUPPLY 04:1B	

MFM21	
PT INPUT	CT INPUT
L1	L2
L3	L4
L5	L6
L7	L8
L9	L10
L11	L12
L13	L14
L15	L16
L17	L18
L19	L20
L21	L22
L23	L24
L25	L26
L27	L28
L29	L30
L31	L32
L33	L34
L35	L36
L37	L38
L39	L40
L41	L42
L43	L44
L45	L46
L47	L48
L49	L50
L51	L52
L53	L54
L55	L56
L57	L58
L59	L60
L61	L62
L63	L64
L65	L66
L67	L68
L69	L70
L71	L72
L73	L74
L75	L76
L77	L78
L79	L80
L81	L82
L83	L84
L85	L86
L87	L88
L89	L90
L91	L92
L93	L94
L95	L96
L97	L98
L99	L100

INVENTORY NO.	REV. NO.	DATE	DESCRIPTION	BY	APPD.	APPROVED	NAME	SIGN.	DATE	SCALE	JOB NO.	DRG. NO.	NO. OF SHEETS	SHEET NO.	REV.
	1								05.06.15	MA	CP-14-053	EP-3-CS-053-009	10	02	00
	2														
	3														
	4														

BHARAT HEAVY ELECTRICALS LIMITED
ELECTROPROTECTIANS DIVISION BANGALORE

TITLE :
POWER & CONTROL SCHEME
NORMAL DG INCOMER-A



NO. OF SHEETS: 10
SHEET NO.: 02

DRG. NO. EP-3-CS-053-009

INVENTORY NO.	4	NAME		SCALE	VA	JOB NO.	CP-14-053	DRG. NO.	EP-3-CS-053-009
REV. NO.	1	DESIGNED	JAGADISH	DATE	05.06.15	TITLE :	BHARAT HEAVY ELECTRICALS LIMITED ELECTROPROTECTIANS DIVISION BANGALORE		
DATE		DRAWN		CHECKED	TRINATH	05.06.15	POWER & CONTROL SCHEME		
				APPD.	KSB	05.06.15	NORMAL DG INCOMER-A		
				APPROVED			NO. OF SHEETS : 10		
							SHEET NO. : 03		
							REV. NO. : 00		

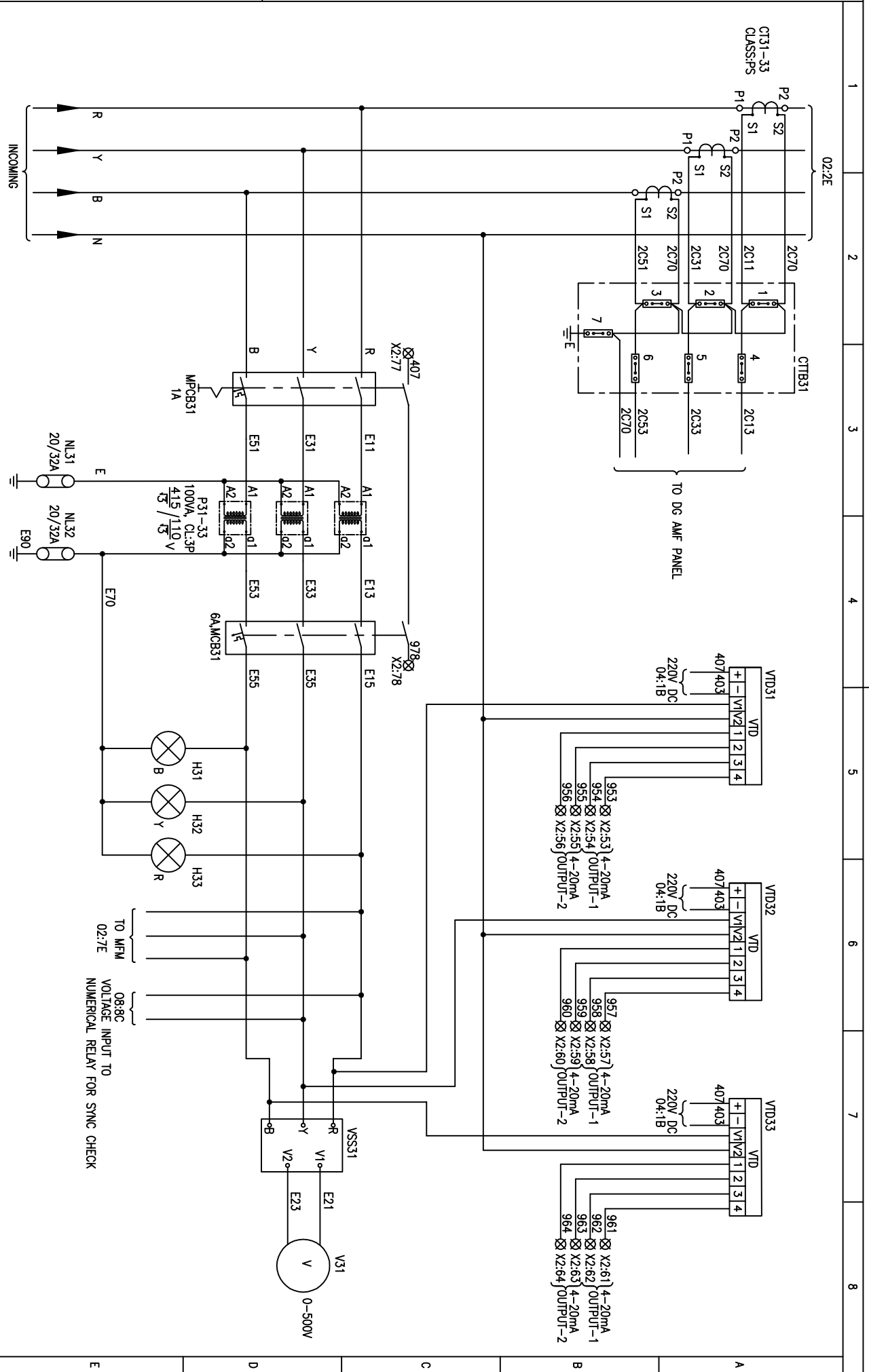

FIRST ANGLE PROJECTION

ALL DIMENSIONS ARE IN MM.

DRG. NO. EP-3-CS-053-009

INVENTORY NO.

REV. NO.	1
DATE	

REV. NO.	DATE	DESCRIPTION	BY	APPD.	APPROVED	KSB
1						
2						
3						
4						

NAME	SIGN.	DATE
JAGADISH		05.06.15
TRINATH		05.06.15

SCALE: NA	JOB NO. CP-14-053	DRG. NO. EP-3-CS-053-009
BHARAT HEAVY ELECTRICALS LIMITED ELECTROPROTECTIANS DIVISION BANGALORE		
TITLE: POWER & CONTROL SCHEME NORMAL DG INCOMER-A		
NO. OF SHEETS: 10	SHEET: 04	REV. 00

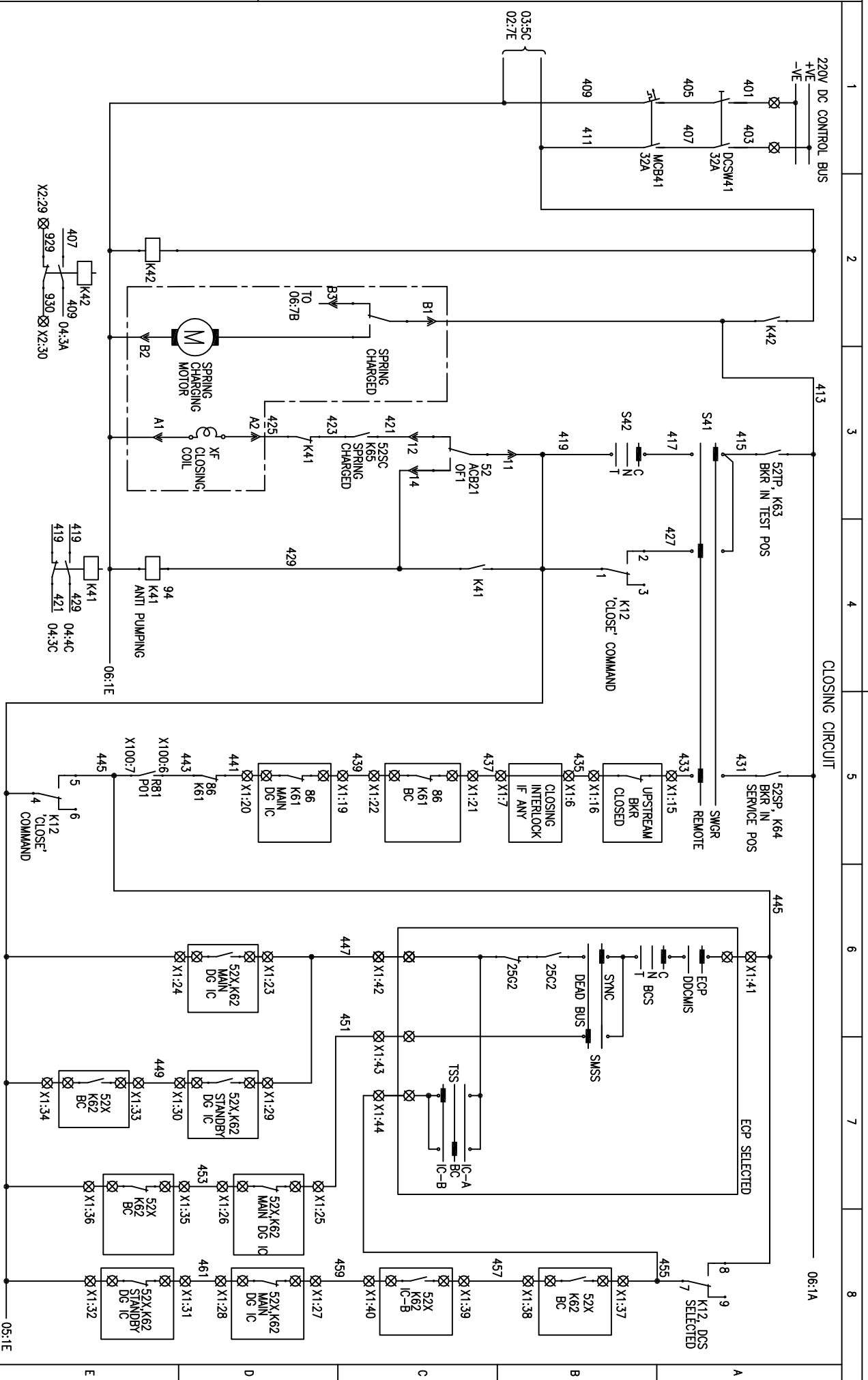

FIRST ANGLE PROJECTION

ALL DIMENSIONS ARE IN MM.

DRG. NO. EP-3-CS-053-009

INVENTORY NO.		BY		APPD.		APPROVED		NAME		SIGN.		DATE		SCALE: NA		JOB NO. CP-14-053		DRG. NO. EP-3-CS-053-009		
1	2	3	4	1	2	1	2	JAGADISH	<i>Jagadish</i>	05.06.15			TITLE : POWER & CONTROL SCHEME NORMAL DG INCOMER-A		NO. OF SHEETS: 10		SHEET NO.: 06		REV. NO.: 00	
REV.	DATE	DESCRIPTION	BY	APPD.	APPROVED	KSB	TRINATH	05.06.15	DESIGNED	05.06.15	05.06.15									

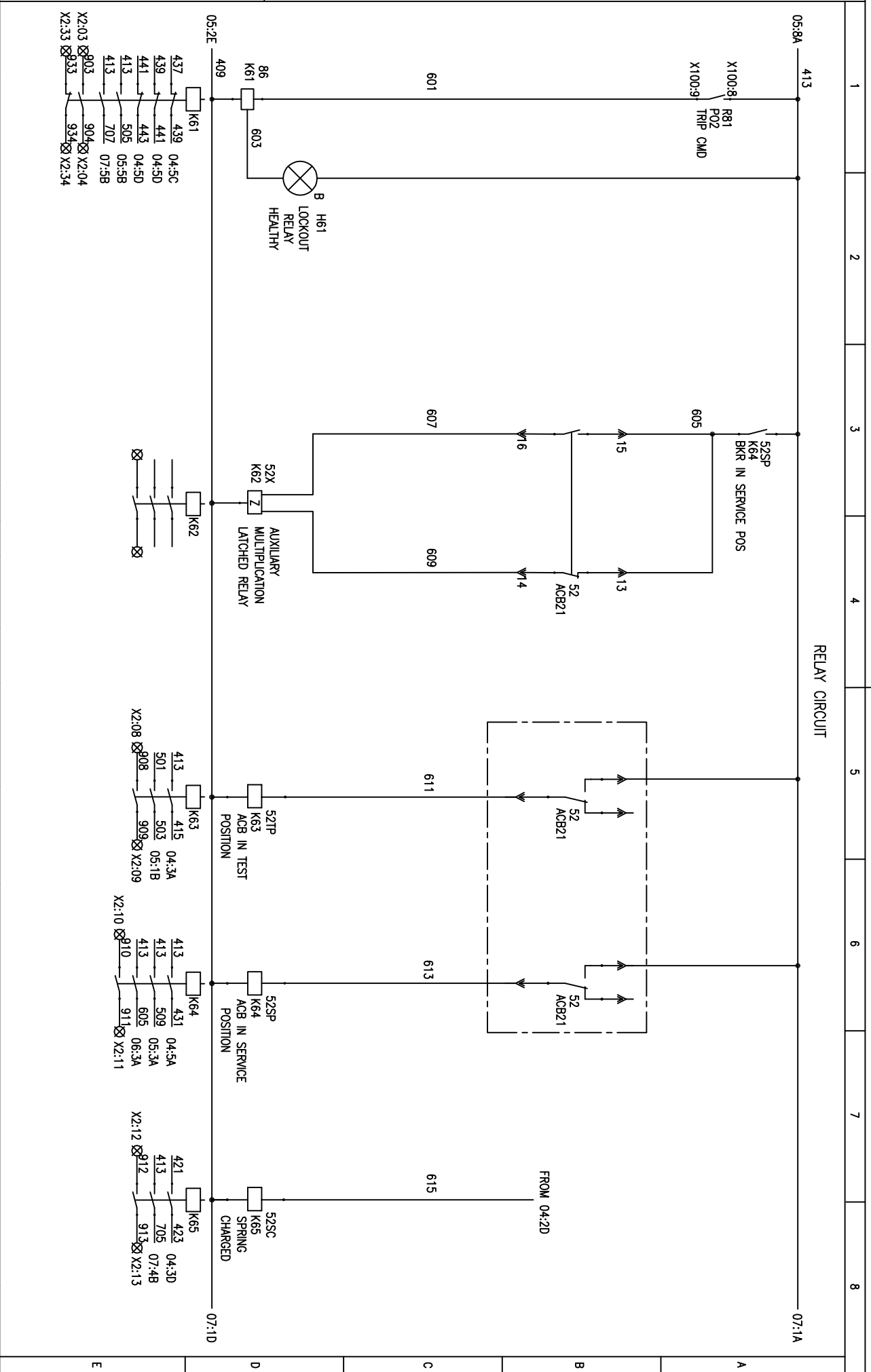

RELAY CIRCUIT

FROM 04:2D

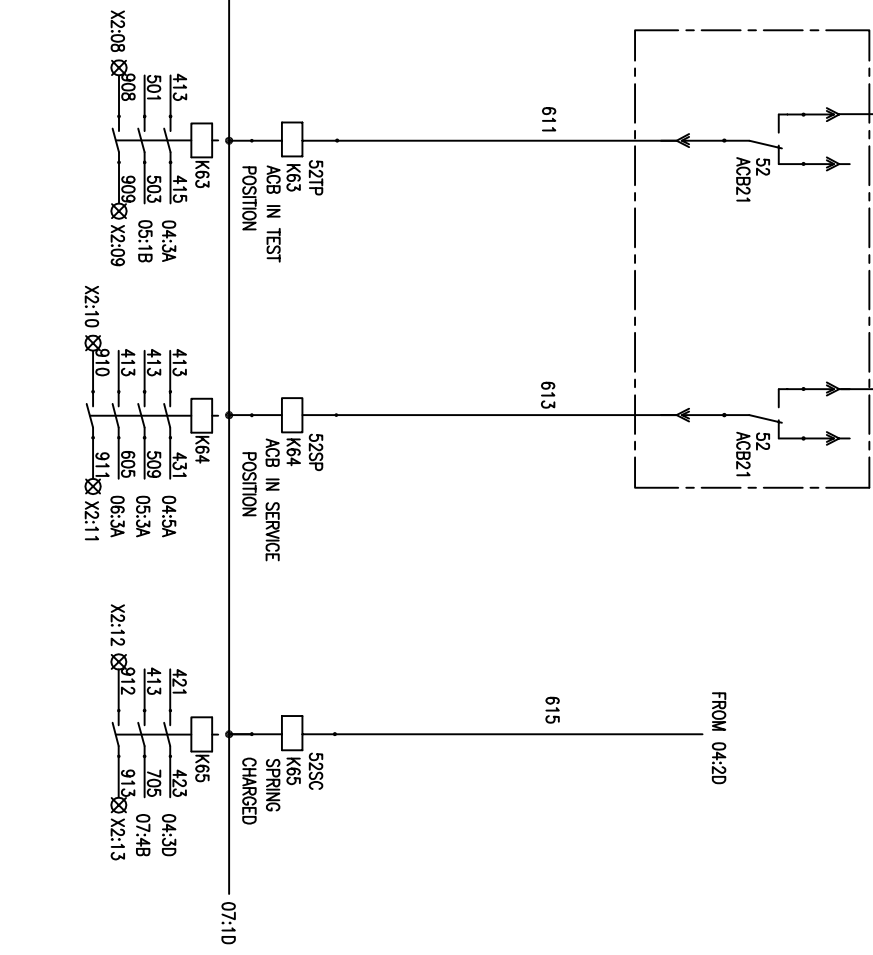
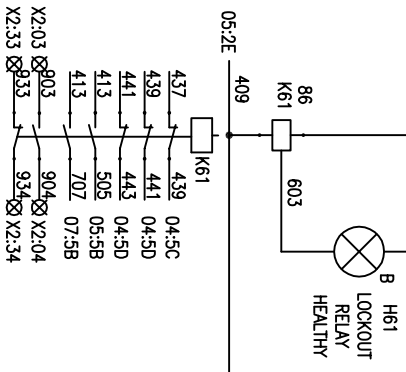

DRG. NO. EP-3-CS-053-009

INVENTORY NO.

FIRST ANGLE PROJECTION

ALL DIMENSIONS ARE IN MM.

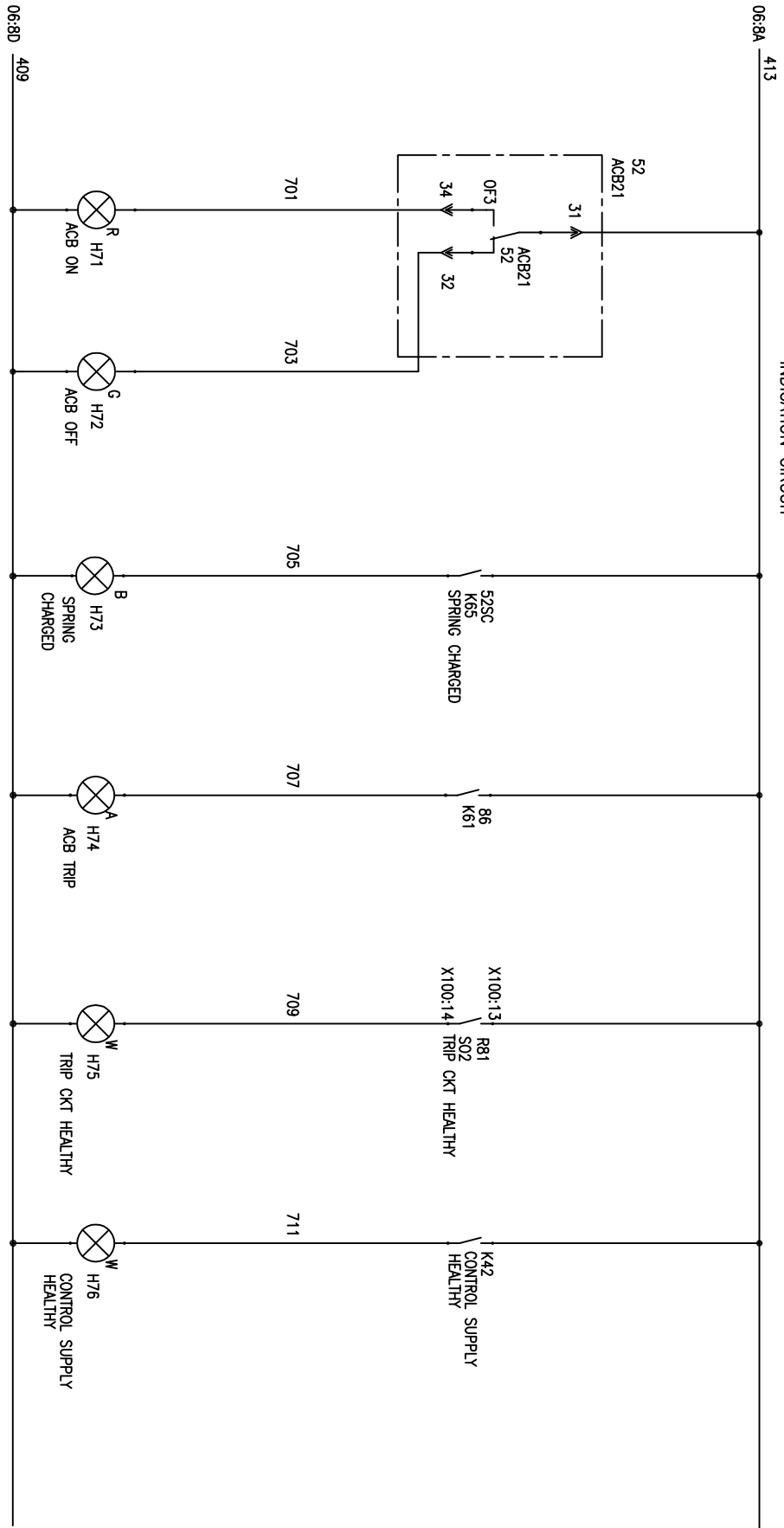

REV. NO.	DATE	DESCRIPTION	BY	APPD.	APPROVED	KSB	DATE	SCALE	JOB NO.	DRG. NO.	NO. OF SHEETS	SHEET NO.	REV.
1					CHECKED	TRINATH	05.06.15	MA	CP-14-053	EP-3-CS-053-009	10	07	00
2					DRAWN								
3					DESIGNED	JAGADISH	05.06.15						
4													

BHARAT HEAVY ELECTRICALS LIMITED
ELECTROPOWERCELLS DIVISION BANGALORE

TITLE :
POWER & CONTROL SCHEME
NORMAL DG INCOMER-A

R81, NUMERICAL RELAY TYPE: REF615

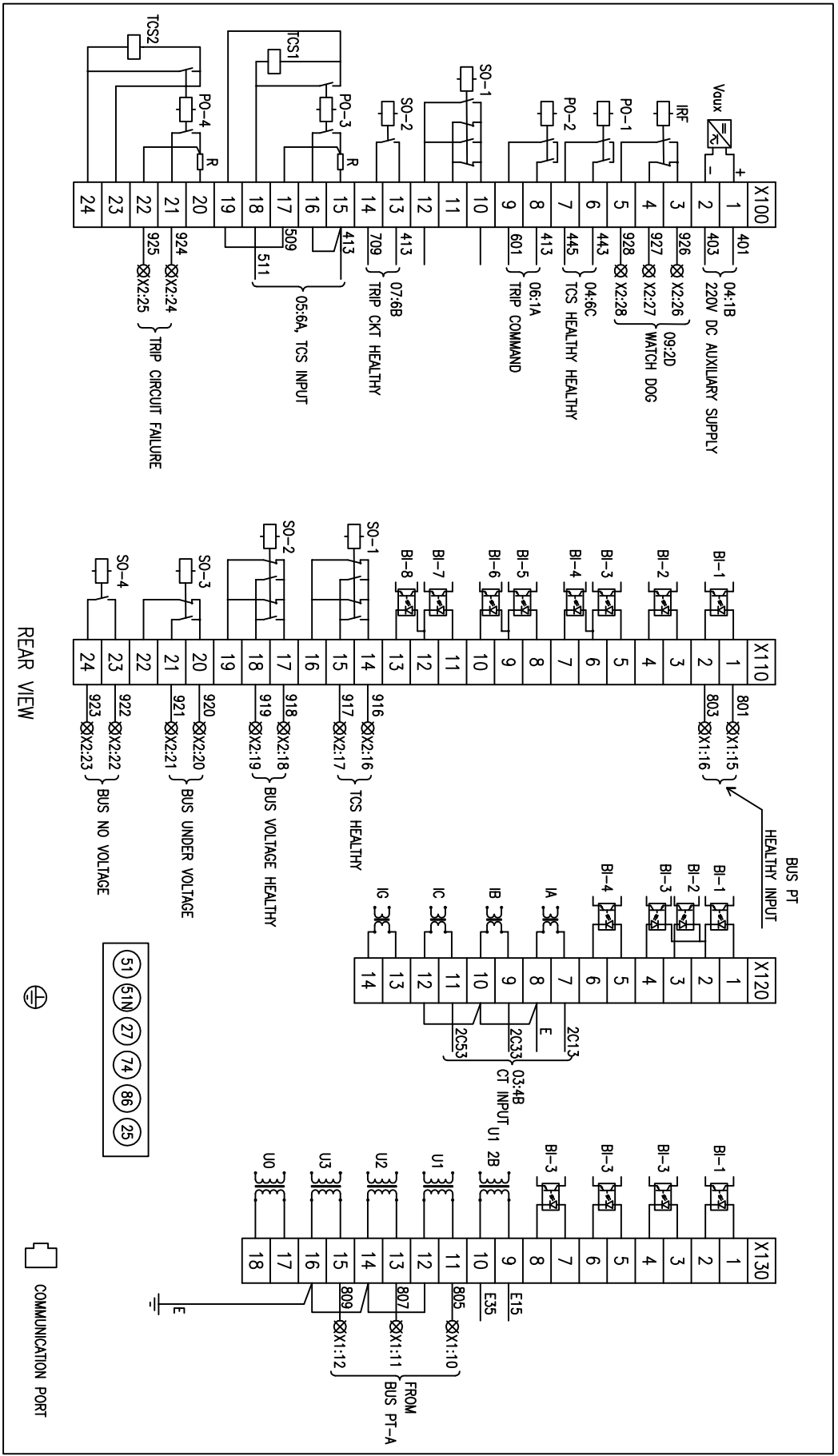

1	2	3	4	5	6	7	8
FIRST ANGLE PROJECTION				ALL DIMENSIONS ARE IN MM			

INVENTORY NO.	4											
REV. NO.	1	2	3									
DATE												
DESCRIPTION												
BY												
APPD.												
APPROVED												
NAME												
SIGN.												
DATE												
SCALE												
JOB NO.												
DRG. NO.												
TITLE	BHARAT HEAVY ELECTRICALS LIMITED ELECTROPROTECTIANS DIVISION BANGALORE											
	POWER & CONTROL SCHEME NORMAL DG INCOMER-A											
NO. OF SHEETS	10											
SHEET NO.	08											
REV.	00											

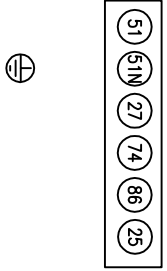

DRG. NO. EP-3-CS-053-009

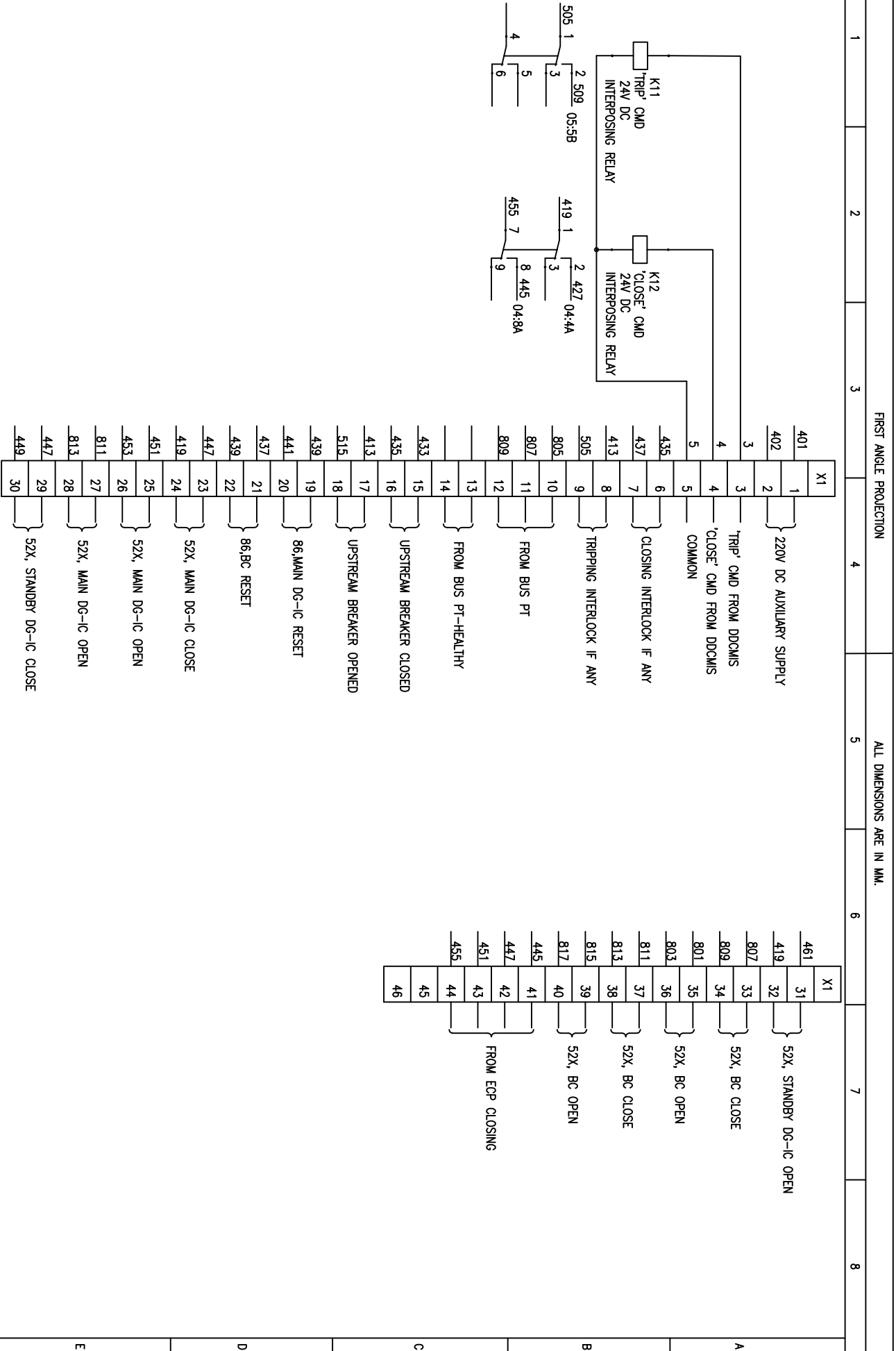

REV. NO.	DATE	DESCRIPTION	BY	APPD.	APPROVED	KSB	NAME	SIGN.	DATE
1					CHECKED		TRINATH		16.12.15
2					DRAWN				
3					DESIGNED		JAGADISH		16.12.15
4									

BHARAT HEAVY ELECTRICALS LIMITED
ELECTROPROTECTIANS DIVISION BANGALORE

TITLE : **POWER & CONTROL SCHEME**
NORMAL DG INCOMER-A

JOB NO. CP-14-053

DRG. NO. EP-3-CS-053-009

NO. OF SHEETS: 10
SHEET NO.: 10

REV. NO.: 00

FIRST ANGLE PROJECTION

ALL DIMENSIONS ARE IN MM.

1

2

3

4

5

6

7

8

CUSTOMER:



TELANGANA STATE POWER GENERATION CORPORATION LTD
TELANGANA STATE
INDIA

PROJECT:

4x270 MW BHADRADRI THERMAL POWER STATION
MANUGURU

CUSTOMER CONSULTANT:



DESEIN PRIVATE LTD

COPYRIGHT AND CONFIDENTIAL

The information on the document is the property of BHARAT HEAVY ELECTRICALS LIMITED
It must not be used directly or indirectly in any way detrimental to the interest of the company

DRG. NO. EP-3-CS-053-010

INVENTORY NO.

REV. NO.	DATE	DESCRIPTION	BY	APPD.	APPROVED	NAME	SIGN.	DATE
1					CHECKED	TRINATH		05.06.15
2					DRAWN	JAGADISH		05.06.15
3					DESIGNED	JAGADISH		05.06.15
4								



BHARAT HEAVY ELECTRICALS LIMITED

ELECTROFORCELANS DIVISION BANGALORE

TITLE :

POWER & CONTROL SCHEME
NORMAL DG INCOMER-B

JOB NO. CP-14-053

DRG. NO. EP-3-CS-053-010



NO. OF SHEETS 10

SHEET NO. 01



REV. 00

DRG. NO. EP-3-CS-053-010

FIRST ANGLE PROJECTION

ALL DIMENSIONS ARE IN MM.

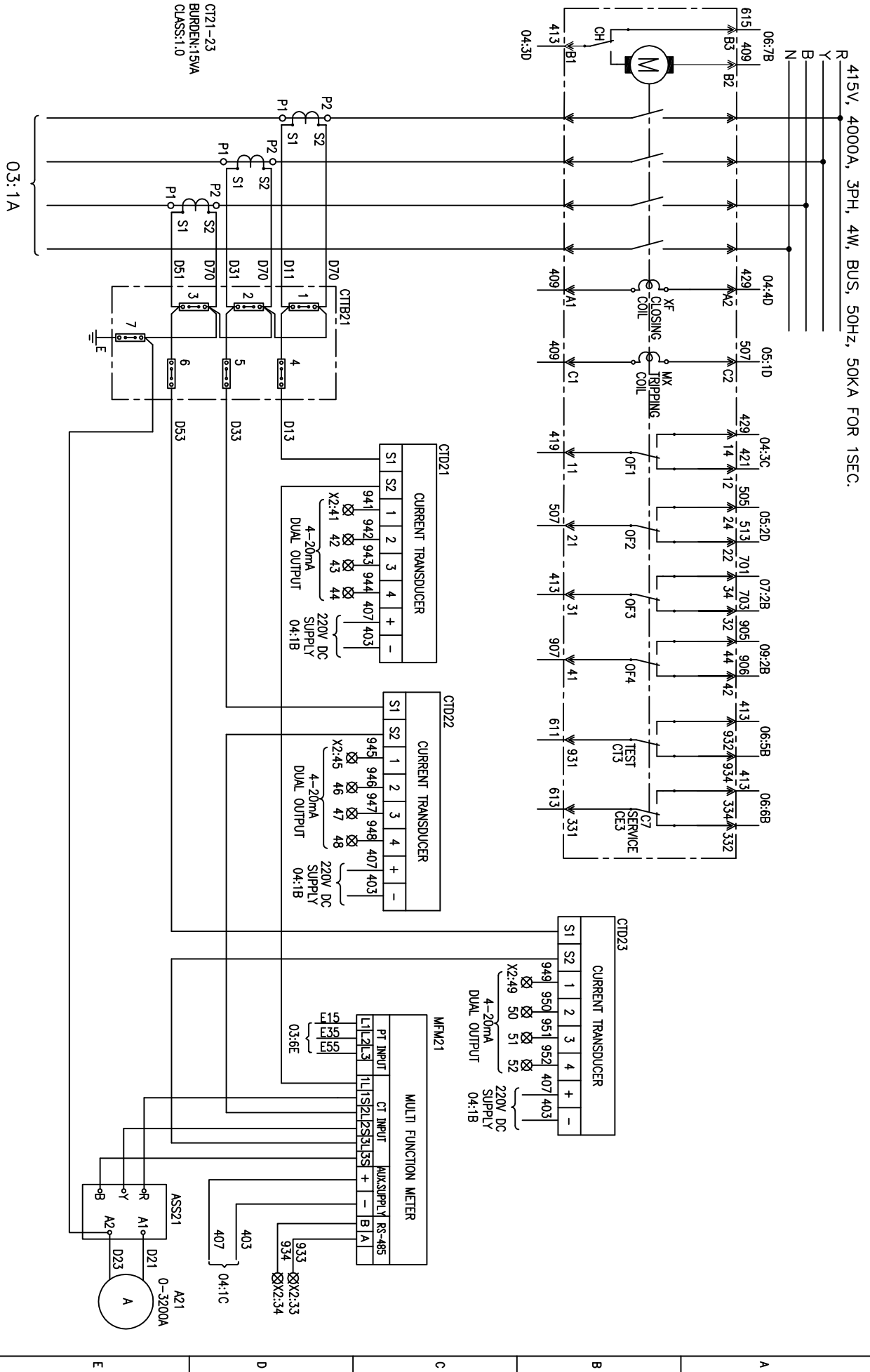

CT21-23
BURDEN:15VA
CLASS:1.0

03:1A

CTD21		CTD22	
S1	S2	S1	S2
1	2	1	2
3	4	3	4
+	-	+	-
941	942	945	946
943	944	947	948
407	403	407	403
X2:41	X2:42	X2:45	X2:46
X2:43	X2:44	X2:47	X2:48
4-20ma DUAL OUTPUT		4-20ma DUAL OUTPUT	
220V DC SUPPLY 04:1B		220V DC SUPPLY 04:1B	

CTD23	
S1	S2
1	2
3	4
+	-
949	950
951	952
407	403
X2:49	X2:50
X2:51	X2:52
4-20ma DUAL OUTPUT	
220V DC SUPPLY 04:1B	

MFN21	
PT. INPUT	CT INPUT
L1	L2
L3	L4
L5	L6
L7	L8
L9	L10
L11	L12
L13	L14
L15	L16
L17	L18
L19	L20
L21	L22
L23	L24
L25	L26
L27	L28
L29	L30
L31	L32
L33	L34
L35	L36
L37	L38
L39	L40
L41	L42
L43	L44
L45	L46
L47	L48
L49	L50
L51	L52
L53	L54
L55	L56
L57	L58
L59	L60
L61	L62
L63	L64
L65	L66
L67	L68
L69	L70
L71	L72
L73	L74
L75	L76
L77	L78
L79	L80
L81	L82
L83	L84
L85	L86
L87	L88
L89	L90
L91	L92
L93	L94
L95	L96
L97	L98
L99	L100

REV. NO.	DATE	DESCRIPTION	BY	APPD.	APPROVED	KSB	SCALE: NA	JOB NO. CP-14-053	DRG. NO. EP-3-CS-053-010
1					CHECKED	TRINATH	05.06.15		
2					DRAWN				
3					DESIGNED	JAGADISH	05.06.15		
4									

BHARAT HEAVY ELECTRICALS LIMITED
ELECTROPROTECTIANS DIVISION BANGALORE

TITLE :
POWER & CONTROL SCHEME
NORMAL DG INCOMER-B

NO. OF SHEETS 10
SHEET NO. 02

REV. 00

DRG. NO. EP-3-CS-053-010

INVENTORY NO.	4	NAME	TRINATH	DATE	05.06.15	SCALE	1:1	JOB NO.	CP-14-053	DRG. NO.	EP-3-CS-053-010
REV. NO.	1	DESIGNED	JAGADISH	DATE	05.06.15		TITLE : POWER & CONTROL SCHEME NORMAL DG INCOMER-B	NO. OF SHEETS : 10 SHEET NO. : 03			
DATE	2	DRAWN		05.06.15							
DESCRIPTION	3	CHECKED		05.06.15							
BY		APPD.	KSB	APPROVED				REV.	00		

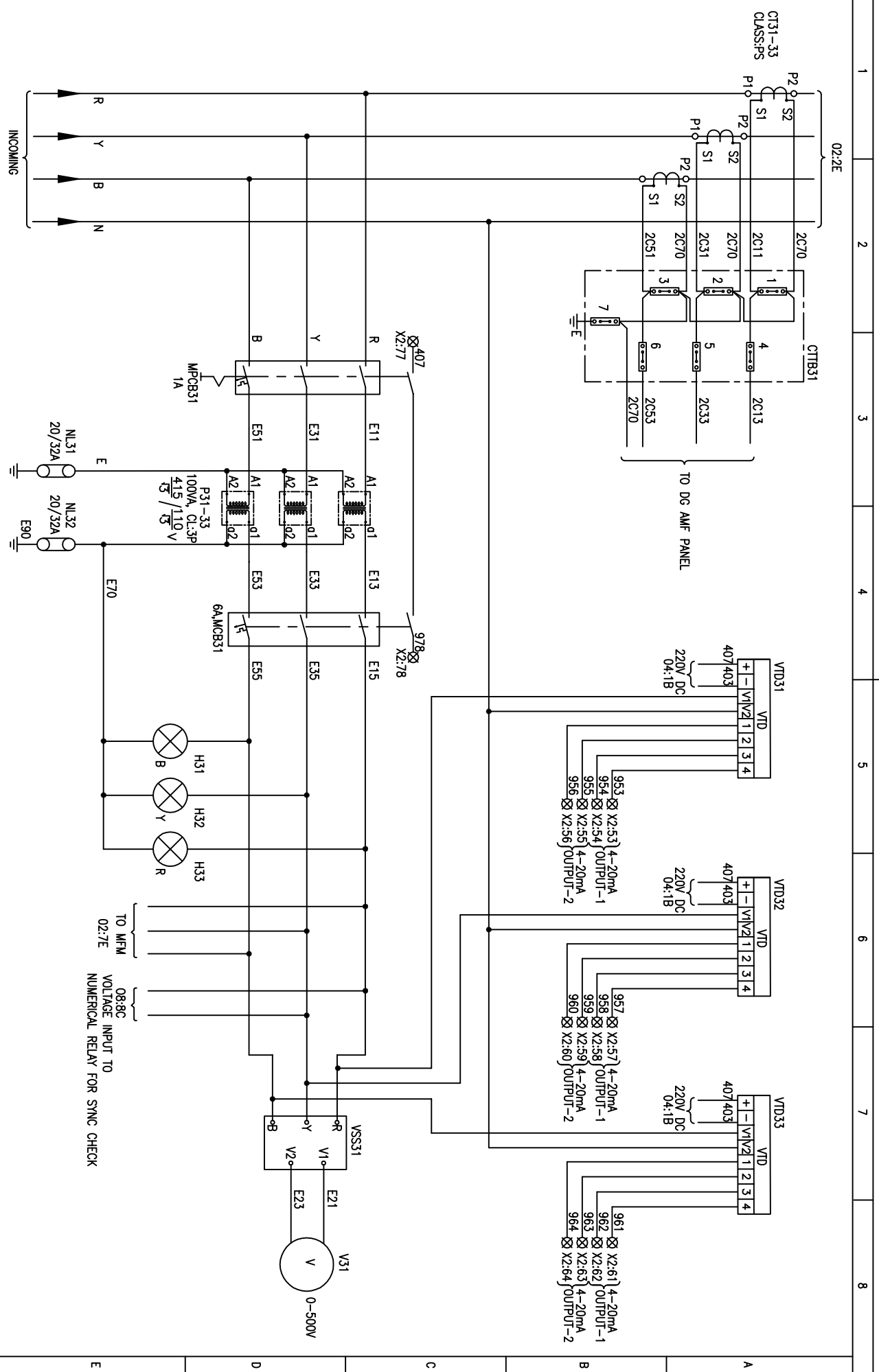

FIRST ANGLE PROJECTION

ALL DIMENSIONS ARE IN MM

DRG. NO. EP-3-CS-053-010

INVENTORY NO.	REV. NO.	DATE	DESCRIPTION	BY	APPD.	APPROVED	NAME	SIGN.	DATE	SCALE	JOB NO.	DRG. NO.
1	1								05.06.15	NA	CP-14-053	EP-3-CS-053-010
2	2								05.06.15			
3	3								05.06.15			
4	4											

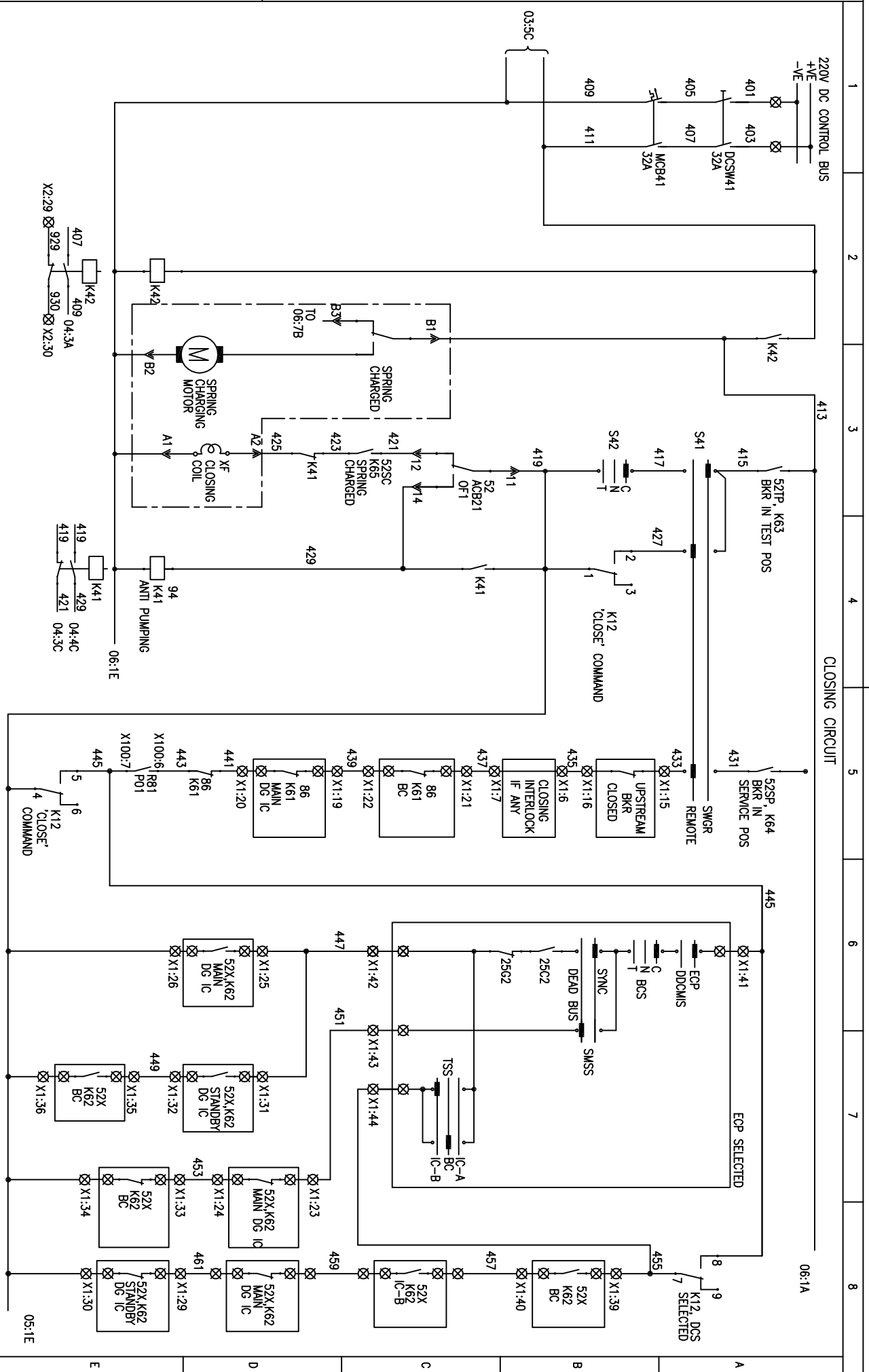

BHARAT HEAVY ELECTRICALS LIMITED
ELECTROPOWERCELLS DIVISION BANGALORE

TITLE :
POWER & CONTROL SCHEME
NORMAL DG INCOMER-B

NO. OF SHEETS	SHEET NO.	REV.
10	04	00

DRG. NO. EP-3-CS-053-010

FORM 66-271 A3

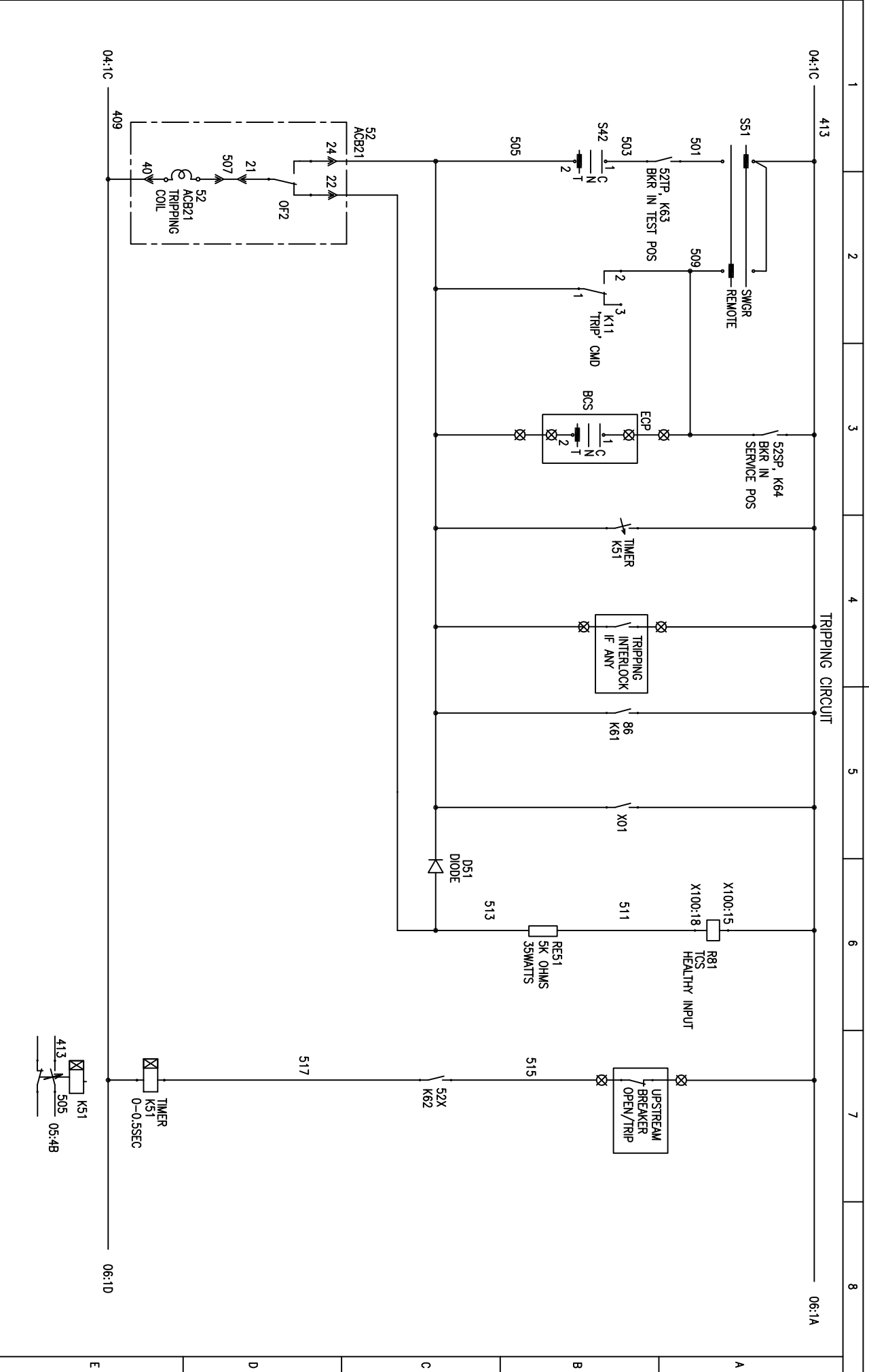

FIRST ANGLE PROJECTION

ALL DIMENSIONS ARE IN MM.

REV. NO.	DATE	DESCRIPTION	BY	APPD.	APPROVED	NAME	SIGN.	DATE	SCALE	JOB NO.	DRG. NO.	NO. OF SHEETS	REV.
1					CHECKED	TRINATH		05.06.15	NA	CP-14-053	EP-3-CS-053-010	10	05
2					DRAWN			05.06.15					
3					DESIGNED	JAGADISH		05.06.15					
4													

BHARAT HEAVY ELECTRICALS LIMITED
ELECTROPROTECTIANS DIVISION BANGALORE

TITLE :
POWER & CONTROL SCHEME
NORMAL DG INCOMER-B



NO. OF SHEETS: 10
SHEET NO.: 05
REV. NO.: 00

DRG. NO. EP-3-CS-053-010

FIRST ANGLE PROJECTION

ALL DIMENSIONS ARE IN MM

RELAY CIRCUIT

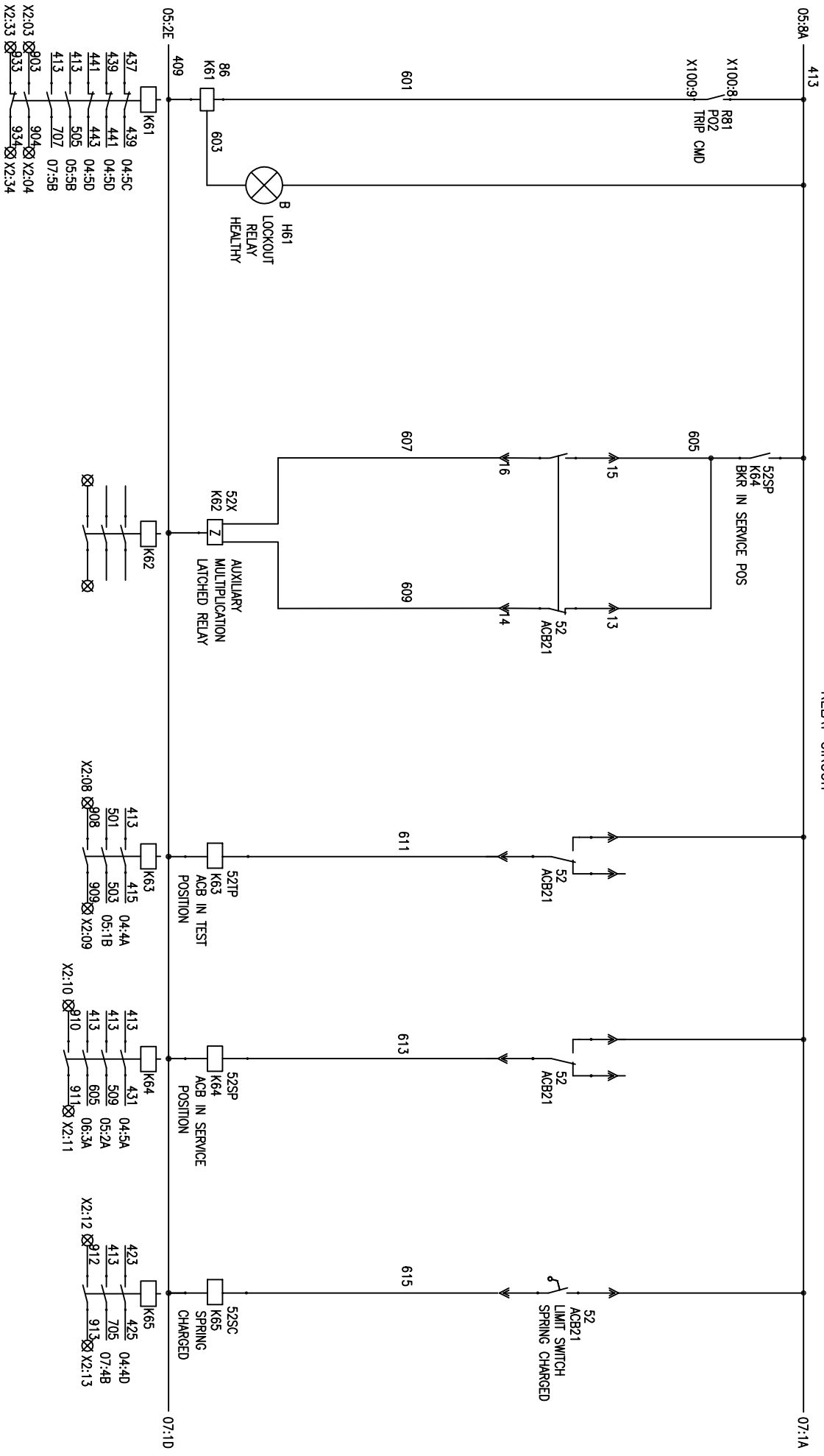

INVENTORY NO.	REV. NO.	DATE	DESCRIPTION	BY	APPD.	APPROVED	NAME	SIGN.	DATE	SCALE	JOB NO.	DRG. NO.	NO. OF SHEETS	NO. OF SHEETS	REV.
1											CP-14-053	EP-3-CS-053-010	10	06	00
2															
3															
4															

BHARAT HEAVY ELECTRICALS LIMITED
ELECTROPOWERCELLS DIVISION BANGALORE

TITLE :
POWER & CONTROL SCHEME
NORMAL DG INCOMER-B



NO. OF SHEETS: 10
SHEET NO.: 06

DRG. NO. EP-3-CS-053-010

INVENTORY NO.

REV. NO.	DATE	DESCRIPTION	BY	APPD.	APPROVED	KSB	DATE	SCALE: NA	JOB NO. CP-14-053	DRG. NO. EP-3-CS-053-010	NO. OF SHEETS	SHEET NO.	REV.
1					CHECKED	TRINATH	05.06.15				10	07	00
2					DRAWN		05.06.15						
3					DESIGNED	JAGADISH	05.06.15						
4													

FIRST ANGLE PROJECTION

ALL DIMENSIONS ARE IN MM.

INDICATION CIRCUIT

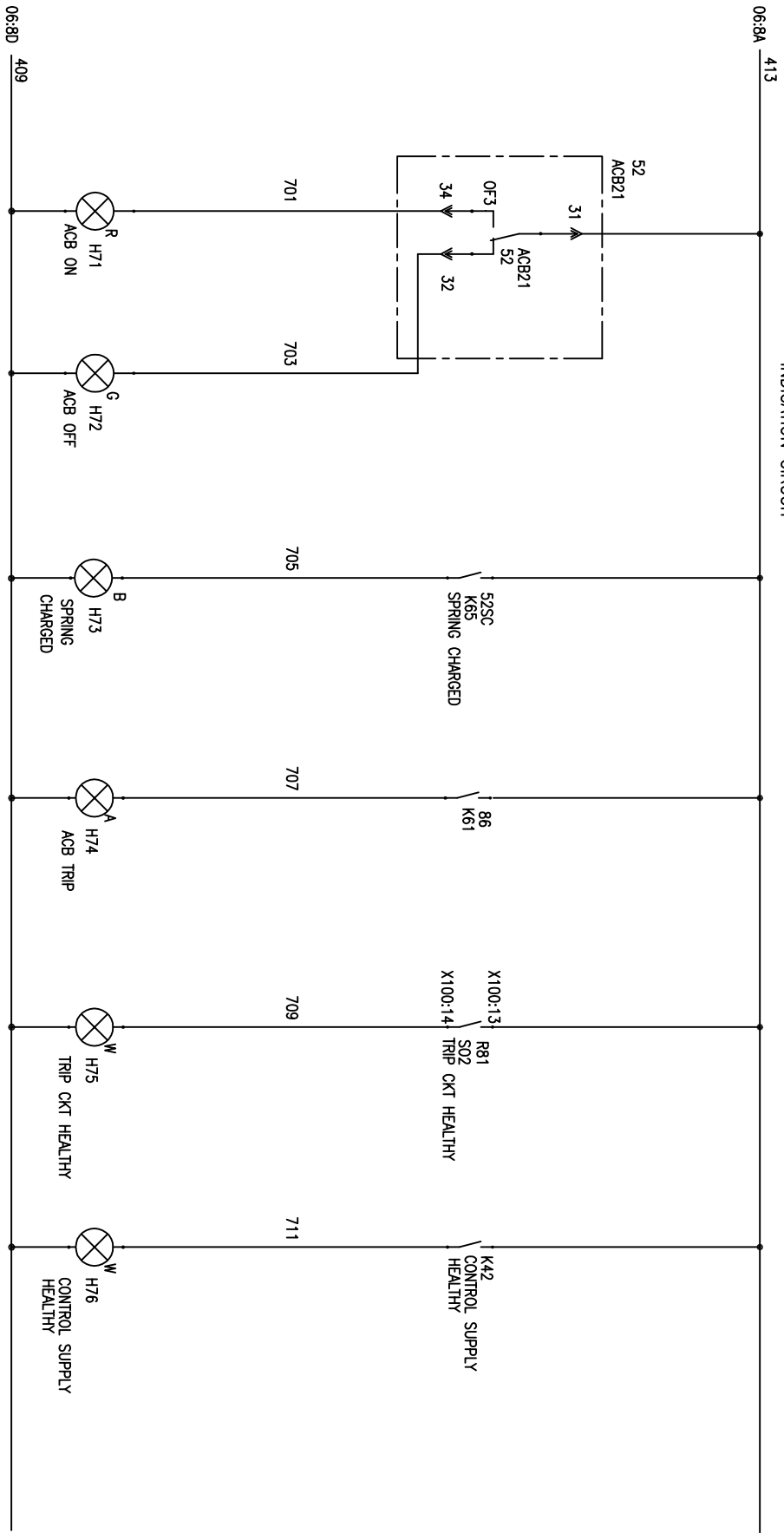

A
B
C
D
E

BHARAT HEAVY ELECTRICALS LIMITED
ELECTROPOWERCELLS DIVISION BANGALORE

TITLE :
POWER & CONTROL SCHEME
NORMAL DG INCOMER-B



DRG. NO. EP-3-CS-053-010

R81, NUMERICAL RELAY TYPE: REF615

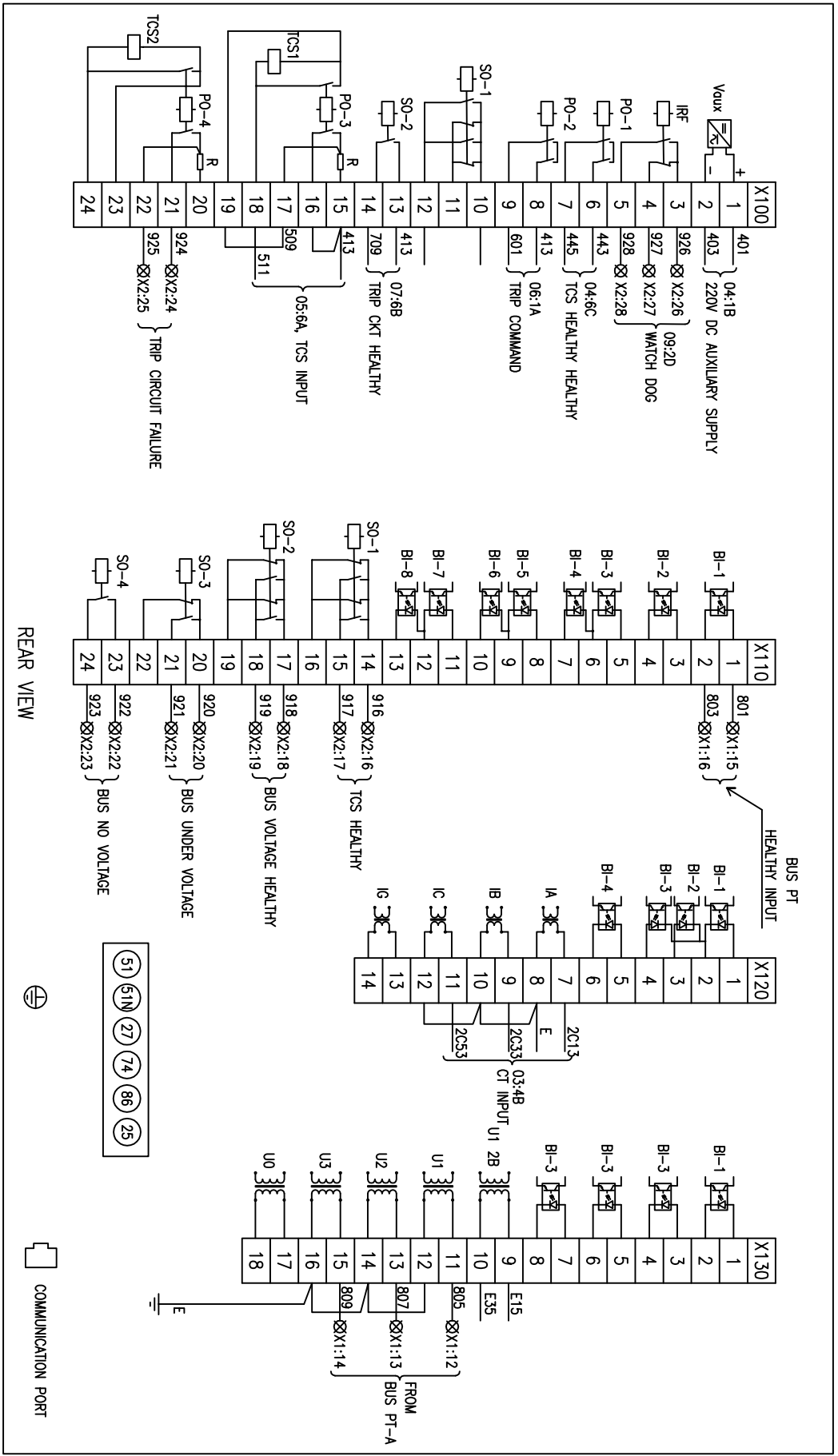

REAR VIEW



COMMUNICATION PORT

1	2	3	4	5	6	7	8
FIRST ANGLE PROJECTION				ALL DIMENSIONS ARE IN MM.			

INVENTORY NO.	4											
REV. NO.	1											
DATE												
DESCRIPTION												
BY												
APPD.												
APPROVED												
		NAME	SIGN.	DATE								
		JAGADISH		16.12.15								
		DESIGNED										
		DRAWN										
		CHECKED										
		TRINATH		16.12.15								
		KSB		16.12.15								
SCALE	NA											
JOB NO.	CP-14-053											
DRG. NO.	EP-3-CS-053-010											
TITLE	BHARAT HEAVY ELECTRICALS LIMITED ELECTROPROTECTIANS DIVISION BANGALORE											
	POWER & CONTROL SCHEME NORMAL DG INCOMER-B											
NO. OF SHEETS	10											
SHEET NO.	08											
REV.	00											

DRG. NO. EP-3-CS-053-010

FIRST ANGLE PROJECTION

ALL DIMENSIONS ARE IN MM.

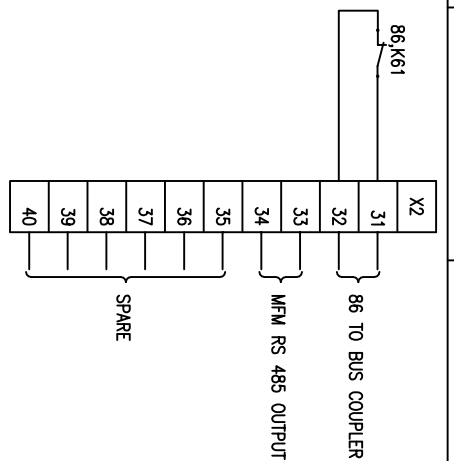
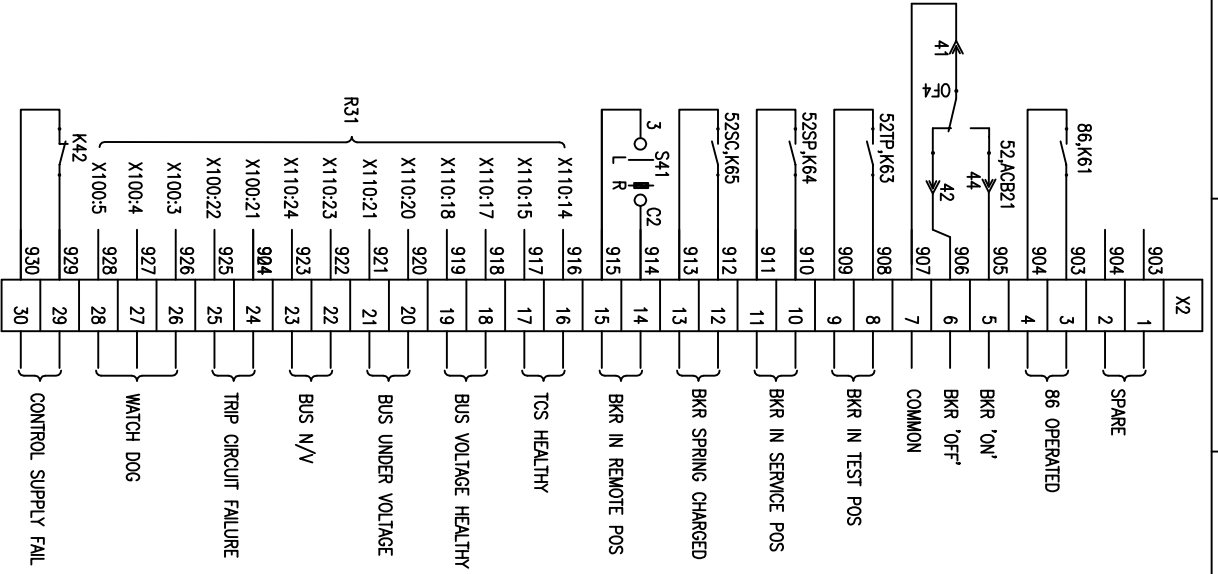

REV. NO.	DATE	DESCRIPTION	BY	APPD.	APPROVED	KSB	NAME	SIGN.	DATE	SCALE: NA	JOB NO. CP-14-053	DRG. NO. EP-3-CS-053-010	NO. OF SHEETS	NO. OF SHEETS	REV.
1					CHECKED		TRINATH		16.12.15				10	09	00
2					DRAWN		JAGADISH		16.12.15						
3					DESIGNED		JAGADISH		16.12.15						
4															

BHARAT HEAVY ELECTRICALS LIMITED
ELECTROPROTECTIANS DIVISION BANGALORE

TITLE :
POWER & CONTROL SCHEME
NORMAL DG INCOMER-B



DRG. NO. EP-3-CS-053-010

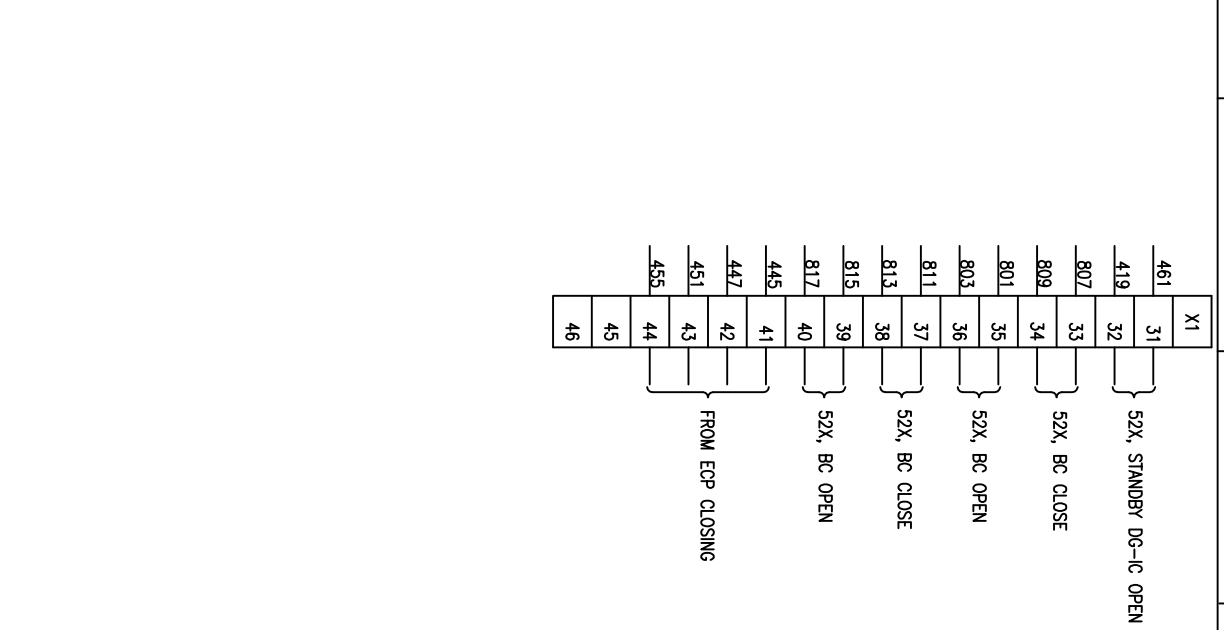
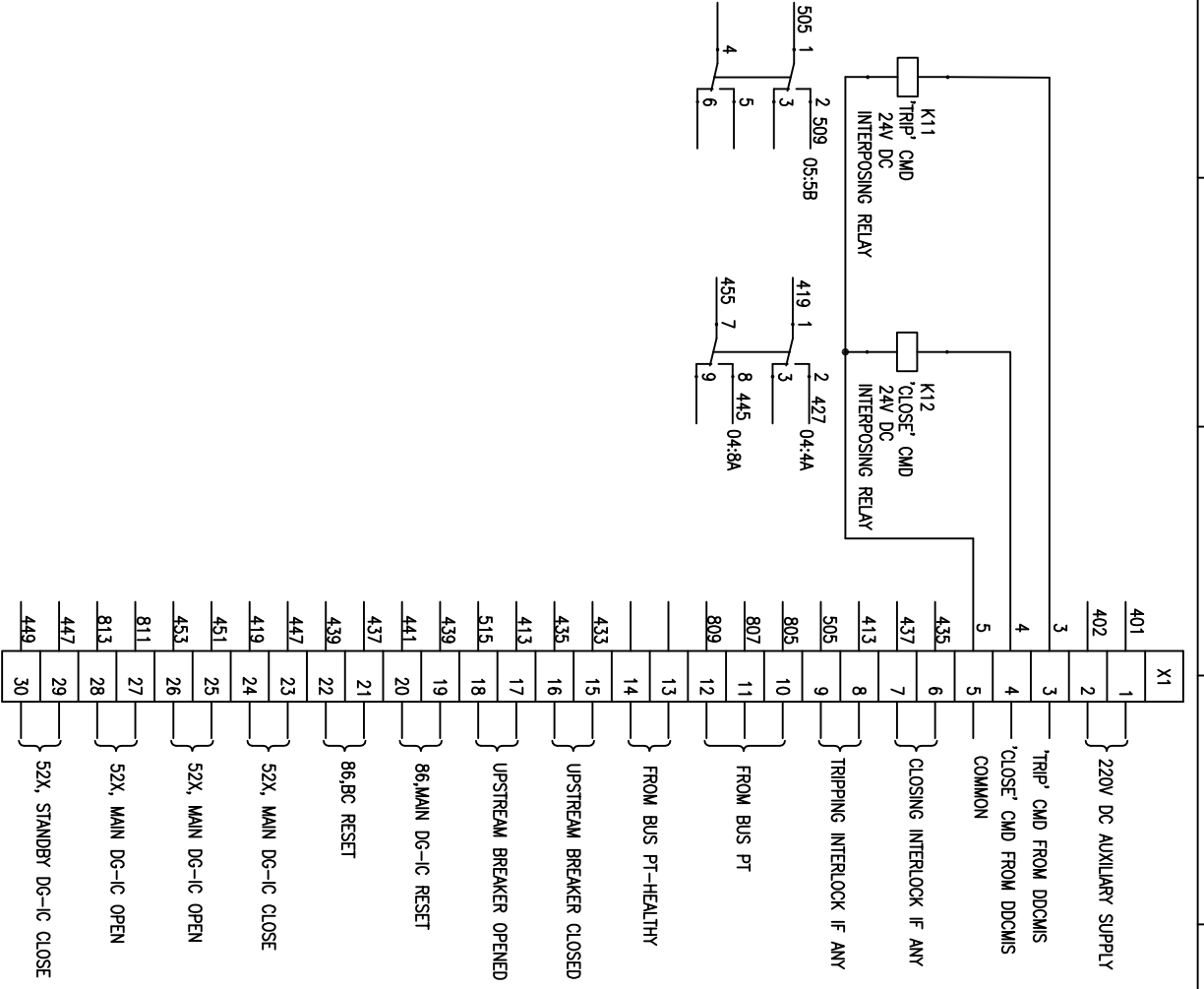

FIRST ANGLE PROJECTION

ALL DIMENSIONS ARE IN MM.

REV. NO.	DATE	DESCRIPTION	BY	APPD.	APPROVED	NAME	SIGN.	DATE	SCALE	JOB NO.	DRG. NO.	NO. OF SHEETS	REV.
1					CHECKED	TRINATH		16.12.15		CP-14-053	EP-3-CS-053-010	10	00
2					DRAWN							10	
3					DESIGNED	JAGADISH		16.12.15				10	
4												10	

BHARAT HEAVY ELECTRICALS LIMITED
ELECTROPROTECTIANS DIVISION BANGALORE

TITLE :
POWER & CONTROL SCHEME
NORMAL DG INCOMER-B

