

SECTION C3, SUB-SECTION II



**SPECIFICATION
FOR
MOTORISED VALVE ACTUATOR**

SPECIFICATION NO.: PE-SS-403-145-I007

VOLUME II B

SECTION D

REV. NO. 00

DATE: 01.08.13

SHEET 2

OF 3

Data Sheet A & B

DATA SHEET-A
(TO BE FILLED BY PURCHASER)

DATA SHEET-B
(TO BE FILLED-UP BY BIDDER)

	@ ENCLOSURE CLASS OF MOTOR	<input type="checkbox"/> IP 67 <input type="checkbox"/> FLAME PROOF	
	@ INSULATION CLASS	CLASS-F TEMP. RISE LIMITED TO CLASS-B	
	@ WINDING TEMP PROTECTION	<input checked="" type="checkbox"/> THERMOSTAT (3 Nos.,1 IN EACH PHASE) <input type="checkbox"/>	
	SINGLE PHASE / WRONG PHASE SEQUENCE PROTECTION	REQUIRED	
INTEGRAL STARTER	INTEGRAL STARTER	<input checked="" type="checkbox"/> REQUIRED <input type="checkbox"/> NOT REQUIRED	
	TYPE OF SWITCHING DEVICE	<input checked="" type="checkbox"/> CONTACTORS <input type="checkbox"/> THYRISTORS	
	TYPE	<input checked="" type="checkbox"/> CONVENTIONAL <input type="checkbox"/> SMART (NON-INTRUSIVE)	
	IF SMART		
	a) SERIAL LINK INTERFACE	<input type="checkbox"/> INTEGRAL <input type="checkbox"/> FIELD MOUNTED	
	b) SERIAL LINK PROTOCOL	<input type="checkbox"/> FOUNDATION FIELD-BUS <input type="checkbox"/> PROFI-BUS <input type="checkbox"/> DEVICE NET <input type="checkbox"/>	
	c) SERIAL LINK MEDIA	<input type="checkbox"/> TWISTED PAIR Cu-CBL <input type="checkbox"/> CO-AXIAL Cu-CBL <input type="checkbox"/> OFC	
	d) HAND HELD PROGRAMMER	<input type="checkbox"/> REQUIRED <input type="checkbox"/> NOT REQUIRED	
	e) TYPE OF HAND HELD PROGRAMMER	<input type="checkbox"/> BLUETOOTH <input type="checkbox"/> INFRARED <input type="checkbox"/>	
	f) MASTER STATION	<input type="checkbox"/> REQUIRED <input type="checkbox"/> NOT REQUIRED	
	g) MASTER STN INTRFACE WITH DCS	<input type="checkbox"/> MODBUS <input type="checkbox"/> TCP/IP	
	h) DETAILS OF SPECIAL CABLE	<input type="checkbox"/> ENCLOSED <input type="checkbox"/> NOT REQUIRED	
	STEP DOWN CONT. TRANSFORMER	<input type="checkbox"/> REQUIRED	
	OPEN / CLOSE PB	<input type="checkbox"/> REQUIRED <input type="checkbox"/> NOT REQUIRED	
	STOP PB	<input type="checkbox"/> REQUIRED <input type="checkbox"/> NOT REQUIRED	
	INDICATING LAMPS	<input type="checkbox"/> REQUIRED <input type="checkbox"/> NOT REQUIRED	
	LOCAL REMOTE S/S	<input type="checkbox"/> REQUIRED <input type="checkbox"/> NOT REQUIRED	
STATUS CONTACTS FOR MONITORING	<input type="checkbox"/> REQUIRED <input type="checkbox"/> NOT REQUIRED		
INTEGRAL STARTER DISTURBED SIGNAL	REQUIRED (O/L RELAY OPERATED, CONT./POWER SUPPLY FAILED, S/S IN LOCAL, TORQUE SWITCH OPTD. MID WAY)		
INTERPOSING RELAY/OPTO COUPLER (Applicable for integral Starter)	TYPE OF ISOLATING DEVICE	<input checked="" type="checkbox"/> INTERPOSING RELAY <input type="checkbox"/> OPTO COUPLER <input type="checkbox"/> EITHER	
	QUANTITY	<input checked="" type="checkbox"/> 2 NOs. <input type="checkbox"/> 3 NOs.	
	DRIVING VOLTAGE	<input checked="" type="checkbox"/> 20.5 – 24V DC <input type="checkbox"/> _____ V DC	
	DRIVING CURRENT	<input checked="" type="checkbox"/> 125mA MAX <input type="checkbox"/> _____ mA MAX	
	LOAD RESISTANCE	<input checked="" type="checkbox"/> > 192 ohms - <25 k ohms <input type="checkbox"/> > _____ ohms - < _____ ohms	
TORQUE SWITCH (Not Applicable for Smart Actuator) (\$\$ Refer Notes)	MFR & MODEL NO.	BIDDER TO SPECIFY	
	OPEN / CLOSE	<input checked="" type="checkbox"/> 1 No. <input type="checkbox"/> 2Nos. / <input checked="" type="checkbox"/> 1 No. <input type="checkbox"/> 2Nos	
	CONTACT TYPE	2 NO + 2 NC	
	RATING	5A 240V AC AND 0.5A 220V DC	
	CALIBRATED KNOBS(OPEN&CLOSE TS)	REQUIRED FOR SETTING DESIRED TORQUE	
	ACCURACY	+3% OF SET VALUE	
LIMIT SWITCH (Not Applicable for Smart Actuator) (\$\$ Refer Notes)	MFR & MODEL NO.	BIDDER TO SPECIFY	
	OPEN : INT : CLOSE	<input checked="" type="checkbox"/> 1 No. <input type="checkbox"/> 2 Nos. 2 Nos. (ADJ.) <input checked="" type="checkbox"/> 1 No. <input type="checkbox"/> 2Nos.	
	CONTACT TYPE	2 NO + 2 NC	
	RATING (AC / DC)	5A 240V AC AND 0.5A 220V DC	

SECTION C3, SUB-SECTION II

	SPECIFICATION FOR MOTORISED VALVE ACTUATOR	SPECIFICATION NO.: PE-SS-403-145-1007			
		VOLUME	II B		
		SECTION	D		
		REV. NO.	00	DATE:	01.08.13
		SHEET	3	OF	3

Data Sheet A & B

DATA SHEET-A
(TO BE FILLED BY PURCHASER)DATA SHEET-B
(TO BE FILLED-UP BY BIDDER)

POSITION TRANSMITTER	POSITION TRANSMITTER (For inching duty & other specific applications)	<input checked="" type="checkbox"/> REQUIRED <input type="checkbox"/> NOT REQUIRED	
	MFR & MODEL NO.	BIDDER TO SPECIFY	
	TYPE	<input type="checkbox"/> ELECTRONIC (2 WIRE) R/I CONVERTER <input checked="" type="checkbox"/> ELECTRONIC (2 WIRE) CONTACTLESS	
	SUPPLY	<input checked="" type="checkbox"/> 24V DC <input type="checkbox"/>	
	OUTPUT	<input checked="" type="checkbox"/> 4-20mA	
	ACCURACY	± 1% FS	
SPACE HEATER	@SPACE HEATER	REQUIRED	
	@ POWER SUPPLY (NON INTEGRAL)	230V AC, 1 PH., 50 Hz	
	@ POWER SUPPLY (INTEGRAL)	BIDDER TO SPECIFY	
	@ RATING		
TERMINAL BOX	ACTUATOR/MOTOR TERMINAL BOX	REQUIRED	
	ENCL CLASS ACTUATOR/MOTOR T.B.	@ <input type="checkbox"/> IP 68 @ <input type="checkbox"/>	
	@ EARTHING TERMINAL	REQUIRED	
	PLUG & SOCKET (9 PIN) (FOR COMMD, LS/TS FEED BACK, PoT)	<input checked="" type="checkbox"/> REQUIRED <input type="checkbox"/> NOT REQUIRED <input checked="" type="checkbox"/> 2 NOS. <input type="checkbox"/>	
CABLE GLANDS	@ POWER CABLE GLAND	SIZE:-----	
	@ SPACE HEATER CABLE GLAND	SIZE:-----	
	OTHER CONTROL CABLE GLANDS-1	<input type="checkbox"/> 1No. for BFV of CW PUMP (Cable size 2Px1.5mm ²)	
	OTHER CONTROL CABLE GLANDS-2	QUANTITY & SIZE :-----	
WEIGHT	TOTAL WEIGHT (ACTUATOR + ACCESSORIES)	BIDDER TO SPECIFY	_____ Kg.

NOTES:

- SCOPE:** DESIGN, MANUFACTURE, INSPECTION, TESTING AND DELIVERY TO SITE OF ELECTRIC ACTUATOR FOR INCHING OR OPEN / CLOSE DUTY.
 - CODES & STANDARDS:** DESIGN AND MATERIALS USED SHALL COMPLY WITH THE RELEVANT LATEST NATIONAL AND INTERNATIONAL STANDARD. AS A MINIMUM, THE FOLLOWING STANDARDS SHALL BE COMPLIED WITH:
IS-9334, IS-2147, IS-2148, IS-325, IS-2959, IS-4691 AND IS-4722
 - TEMPERATURE RISE SHALL BE RESTRICTED TO 70 DEG. C FOR AMBIENT TEMPERATURE OF 50 DEG C.
 - CABLE GLANDS OF DOUBLE COMPRESSION TYPE, BRASS MATERIAL SHALL BE PROVIDED.
 - THE TORQUE SWITCHES SHALL BE PROVIDED WITH MECHANICAL LATCHING DEVICE TO PREVENT OPERATION WHEN UNSEATING FROM THE END POSITIONS. THE LATCHING DEVICE SHALL UNLATCH AS SOON AS THE VALVE LEAVES THE END POSITION. IF SUCH PROVISION IS NOT POSSIBLE, THE TORQUE SWITCHES SHALL BE BYPASSED BY END-POSITION LIMIT SWITCHES WHICH OPENS ON VALVE LEAVING END POSITION. THESE LIMIT SWITCHES ARE ADDITIONAL TO THE NUMBER OF LIMIT SWITCHES SPECIFIED ELSEWHERE.
 - THE MOTOR SHALL OPERATE SATISFACTORILY UNDER THE +/- 10% SUPPLY VOLTAGE VARIATION AT RATED FREQUENCY, -5% TO +3% VARIATION IN FREQUENCY AT RATED SUPPLY VOLTAGE, SIMULTANEOUS VARIATION IN VOLTAGE & FREQUENCY THE SUM OF ABSOLUTE PERCENTAGE NOT EXCEEDING 10%.
 - THE MOTOR SHALL BE SUITABLE FOR DIRECT ON LINE STARTING.
- \$\$ TORQUE SWITCH & LIMIT SWITCH SHALL ACT INDEPENDENT OF EACH OTHER. TANDEM OPERATION IS NOT ACCEPTABLE.**
- ## EPOXY PAINT IS RECOMMENDED FOR COASTAL AREAS.**

NAME	PREPARED BY	CHECKED BY	APPROVED BY	VENDOR COMPANY SEAL
	ANUJ WADHWA	CHETAN MALIK	M.A.MANSOORI	NAME
	SIGNATURE			SIGNATURE
	DATE	20.06.2013	20.06.2013	20.06.2013

NOTES* = TO BE FILLED BY MPL (LEAD AGENCY). @ = TO BE FILLED BY ES

ALL DIMENSIONS ARE IN MILLIMETRES. FOR TOLERANCES OF UNTOLERANCED DIMENSIONS DURING MANUFACTURE REFER RELEVANT QCP / QP.

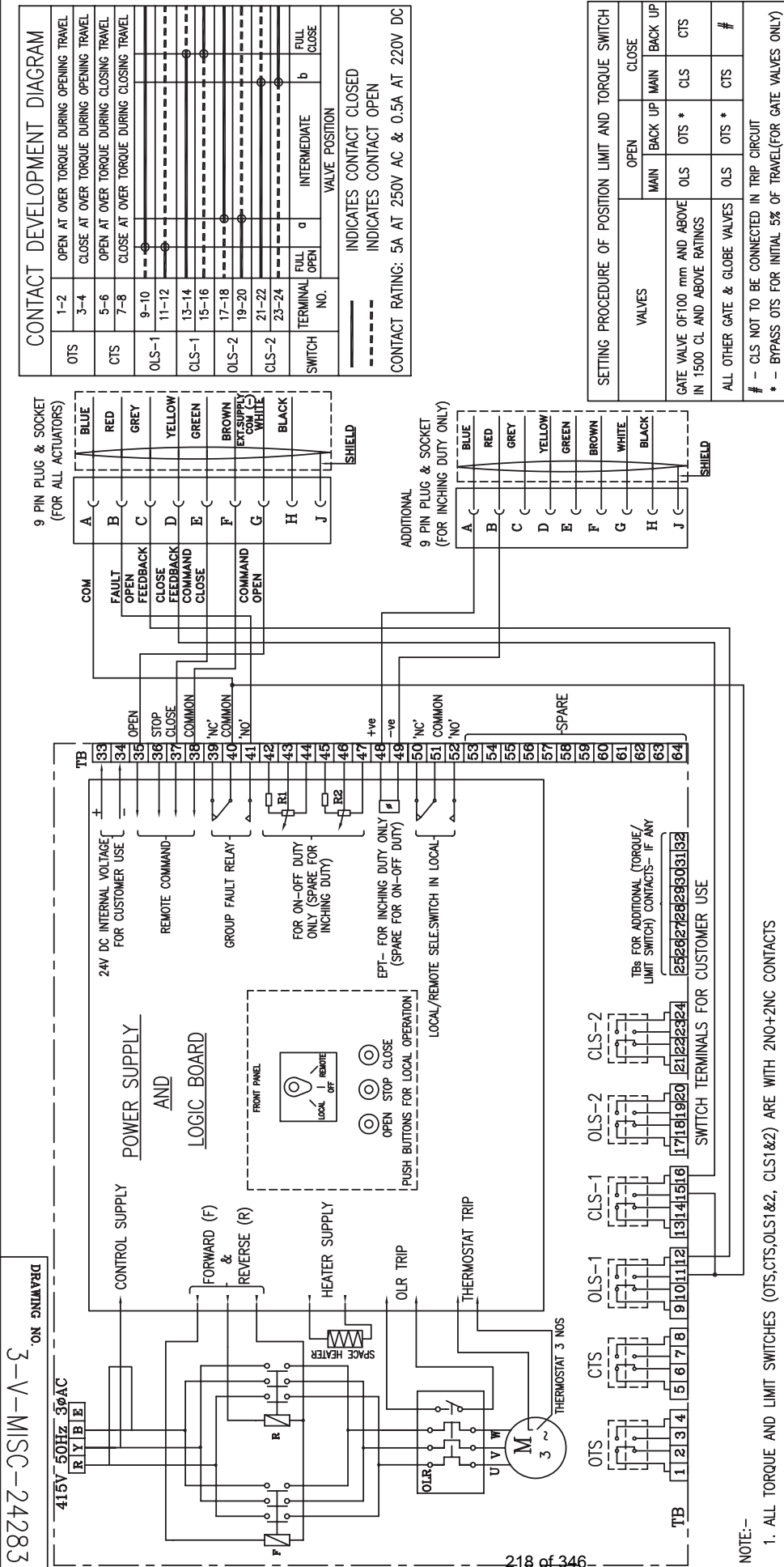

TYPE OF PRODUCT
 ELECTRICAL VALVE ACTUATORS (AC) WITH INTEGRAL STARTERS FOR NTPC PROJECTS

OR NAME OF CUSTOMER/PROJECT
 (DRAWN FOR INTERMEDIATE POSITION OF VALVES)

BHARAT HEAVY ELECTRICALS LTD.,
 UNIT: HIGH PRESSURE BOILER PLANT, TRUCHIRAPALLI-620014.

DEPT VL 365-121
 CODE NIS
 SCALE NIS

WEIGHT (KG) -
 REFERENCE INFORMATION

REV DATE ALTERED
 CHD & APPD

CAUTION: The information on this drawing is the property of BHARAT HEAVY ELECTRICALS LTD. It is to be used directly or indirectly in any way detrimental to the interest of the company.

WIRING DIAGRAM (TERMINAL PLAN)
 FOR ACTUATOR WITH INTEGRAL STARTER WITH PLUG & SOCKET FOR NTPC PROJECTS

DRAWING NO. 3-V-MISC-24283
 REV 0

- NOTE:-**
1. ALL TORQUE AND LIMIT SWITCHES (OTS,CTS,OLS1&2, CLS1&2) ARE WITH 2NO+2NC CONTACTS '1NO+1NC' IS TERMINATED IN TBS 1-24, REMAINING CONTACTS ARE FOR INTERNAL USE. ANY SPARE CONTACTS WHICH ARE NOT USED INTERNALLY ARE TO BE TERMINATED IN TBS 25-32
 2. CTS - TORQUE SWITCHES FOR CW ROTATION (CLOSE)
 3. OTS - TORQUE SWITCHES FOR CCW ROTATION (OPEN)
 4. OLS-1, OLS-2 - LIMITSWITCHES FOR POSITION OPEN
 5. CLS-1, CLS-2 - LIMITSWITCHES FOR POSITION CLOSE
 6. EPT - ELECTRONIC POSITION TRANSMITTER (CONTACTLESS TYPE, FOR INCHING DUTY)
 7. R1-R2-POTENTIOMETER 2 x 100 OHMS (FOR ON-OFF DUTY)
 8. FOR COMMANDS & EPT EITHER INTERNALLY GENERATED 24 VDC OR EXTERNAL SUPPLY OF 24VDC CAN BE USED
 9. M - MOTOR 3ø 415V 50 Hz AC SUPPLY
 10. TORQUE SWITCH BYPASS WITH LIMITSWITCH BOTH ON OPEN & CLOSE DIRECTION TO BE DONE INTERNALLY.



SUB-SECTION-IV: I6

PROCESS CONNECTION AND PIPING

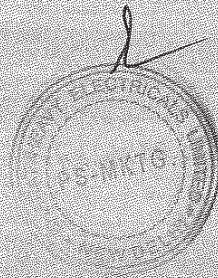



585

894

LARA SUPER THERMAL POWER PROJECT (2x800MW) /
DARLIPALI SUPER THERMAL POWER PROJECT -I (2 x 800MW) /
GAJMARA SUPER THERMAL POWER PROJECT -I (2x 800MW) /
KUDGI SUPER THERMAL POWER PROJECT -I (3 x 800MW)
STEAM GENERATOR PACKAGE

TECHNICAL SPECIFICATION
SECTION-VI
BID DOC NO.: CS-9548/ 9549/ 9566/ 9573-102-2

CLAUSE NO.	TECHNICAL REQUIREMENTS			
PROCESS CONNECTION AND PIPING				
1.00.00	PROCESS CONNECTION PIPING			
1.01.00	The Contractor shall provide, install and test all required material for completeness of Impulse Piping System and Air Piping System as per the requirements of this Sub-section enclosed installation drawings and source connection drawings on as required basis for the connection of instruments and control equipment to the process and make the system complete. The installation & source connection of various items shall generally as per installation drawings (drawing no. 0000-999-POI-A-022 to 034) and source connection drawings (drawing nos. 0000-999-POI-A-035), however, the Contractor shall furnish during detailed engineering all relevant drawings, material and tech. specifications of various items service wise for Employer's approval.			
1.01.01	All materials supplied under this Sub-section shall be suitable for intended service, process, operating conditions and type of instruments used and shall fully conform to the requirements of this specification. The material offered by the Bidder shall be from reputed, experienced manufacturer whose guaranteed and trouble free operation has been proven at least for two years in not less than two pulverized coal fired utility stations.			
1.02.00	IMPULSE PIPING, TUBING, FITTINGS, VALVES AND VALVE MANIFOLDS			
1.02.01	All impulse pipe shall be of seamless type conforming to ANSI B36.10 for schedule numbers, sizes and dimensions etc. The material of the impulse pipe shall be same as that of main process pipe. For various applications specification of associated fittings and valves shall be as given in Table PCP. For protection against sea environment all impulse pipes fittings etc. shall be provided with durable epoxy coating with poly urethane finish.			
1.02.02	Stainless steel tube shall be provided inside enclosures & racks from tee connection to valve manifold and then to instrument. For high pressure/temperature applications (piping class A, B, C & D of the table no. PCP) the material shall be ASTM A 213 TP 316H and for other applications material shall be ASTM A 213 TP 316L. The wall thickness of the tube shall be in accordance with the ANSI B31.1 standard.			
1.02.03	All fittings shall be forged steel and shall conform to ANSI B16.11. The material of forged tube fittings for shaped application (e.g. Tee, elbow etc.) shall be ASTM A 182 Gr. 316 H for high pressure/ temperature applications (as defined above) and ASTM A 182 Gr. 316L for other applications. The material for bar stock tube fitting (for straight application) shall be 316 SS. Metal thickness in the fittings shall be adequate to provide actual bursting strength equal to or greater than those of the impulse pipe or SS tube, with which they are to be used.			
1.02.04	The source shut-off (primary process root valve) and blow down valve shall be of 1/2 inch size globe valve type for all applications except for air and flue gas service wherein no source shut-off valves are to be provided. The disc and seat ring materials of carbon steel and alloy steel valves be ASTM A-105 and ASTM A-182, Gr. F22, hard faced with stellite (minimum hardness - 350 BHN.) The surface finish of 16 RMS or greater is required in the area of stem packing. The valve design shall be such that the seats can be reconditioned and stem and disc may be replaced without removing the valve body from the line.			
1.02.05	The valve manifolds shall be of 316 stainless steel with pressure rating suitable for intended application. 2 valve manifold and 3 valve manifold shall be used for pressure measurements using pressure transmitters/ pressure switches and diff. pressure transmitter/ switches respectively. 5-valve manifold shall be used for remaining applications like DP, flow and level measurements.			
1.02.06	For Pr./D.P gauges in fluid application two-way globe valve on each impulse line to the instrument and in A/F application two-way gate valve on each impulse line to the instrument			
LARA STPP (2x800MW) / DARLIPALI STPP-I (2 x 800MW) / GAJMARA STPP-I (2x 800MW) / KUDGI STPP-I (3 x 800MW) STEAM GENERATOR PACKAGE		TECHNICAL SPECIFICATION SECTION-VI BID DOC NO.: CS-9548/ 9549/ 9566/ 9573-102-2	PART - B SUB-SECTION-IV I-6 (PROCESS CONNECTION & PIPING)	PAGE 1 OF 6

CLAUSE NO.	TECHNICAL REQUIREMENTS 		
2.00.00	shall be provided near the instrument. These shall be in addition to the three ways gauge cock provided along with the pressure /D.P gauges. AIR SUPPLY PIPING		
2.01.00	All pneumatic piping, fittings, valves, air filter cum regulator and other accessories required for instrument air for the various pneumatic devices/ instruments shall be provided.		
2.01.01	This will include as a minimum air supply to pneumatically operated control valves, actuators, instruments, continuous and intermittent purging requirements of etc.		
2.02.00	For individual supply line and control signal line to control valve, 1/4-inch size light drawn tempered copper tubing conforming to ASTM B75 shall be used. The thickness of cu-tubing shall not be less than 0.065 inch and shall be PVC coated. The fittings to be used with copper tubes shall be of cast brass, screwed type.		
2.03.00	All other air supply lines of 1/2 inch to 2 inch shall be of mild steel hot dipped galvanized inside and outside as per IS-1239, heavy duty with threaded ends. The threads shall be as per ASA B.2.1. Fittings material shall be of forged carbon steel A234 Gr. WPB galvanized inside and outside, screwed as per ASA B2.1. Dimensions of fittings shall be as per ASA B16.11 of rating 3000 lbs.		
2.04.00	For air supply to various devices mentioned above, the bidder shall provide 2 inch size GI pipe header with isolation valve from the instrument air and service air terminal points. In the boiler area the 2 inch head shall be provided upto top most elevation of boiler floor and from this 2 inch header, 1 inch sub-header shall be branched off at each floor with isolation valve. From this 1 inch sub-header, branch line of 1/2 inch, with isolation valve shall be provided upto various devices. Similar system is to be followed for service air required for intermittent purging in the Local Instrument Enclosures (LIEs) etc.		
2.05.00	All instrument air filters cum regulator set with mounting accessories shall be provided for each pneumatic device requiring air supply. The filter regulators shall be suitable for 10-kg/sq.cm max. Inlet pressure. The filter shall be of size 5 microns and of material sintered bronze. The air set shall have 2-inch size pressure gauge and built in filter housing blowdown valve. The end connection shall be as per the requirement to be finalized during detailed engineering.		
2.06.00	All the isolation valves in the air supply line shall be gate valves as per ASTM B62 inside screw rising stem, screwed female ends as per ASA B2.1. Valve bonnet shall be union type & trim material shall be stainless steel, body rating 150 pounds ASA. The valve sizes shall be 1/2 inch to 2 inch.		
2.07.00	Purge Air Connection for Air and Flue gas Applications The continuous purging with instrument air shall be done, for all air and flue gas measurements excepting instrument air and service air instruments, at the process source connection end. Necessary arrangements required for continuous purging shall be provided inside all the Air and Flue gas enclosures as per enclosed drawing no. 0000-999-POI-A-034. For intermittent purging with service air, necessary arrangements inside all the air and Flue gas enclosures shall be provided. The SS three way valve provided in the SS tubing shall be used for isolating the transmitter & connecting the service air quick disconnect line.		
LARA STPP (2x800MW) / DARLIPALI STPP-I (2 x 800MW) / GAJIMARA STPP-I (2x 800MW) / KUDGI STPP-I (3 x 800MW) STEAM GENERATOR PACKAGE	TECHNICAL SPECIFICATION SECTION-VI BID DOC NO.: CS-9548/ 9549/ 9566/ 9573-102-2	PART - B SUB-SECTION-IV I-6 (PROCESS CONNECTION & PIPING)	PAGE 2 OF 6

CLAUSE NO.	TECHNICAL REQUIREMENTS		
	<p>Purging arrangement is not required for Instrument air and service air measurement applications.</p>		
3.00.00	INSTALLATION AND ROUTING		
3.01.00	Instrument Piping System		
3.01.01	<p>For steam and liquid measurements, the impulse pipe should preferably slope downward from source connection to instrument and instrument shall be installed below the source point. If due to any reason instrument is installed above the source point, the impulse pipe should slope upwards continuously and a 'pigtail' should be provided at the instrument to assure water seal for temperature protection. For vacuum measurements instrument shall be installed above source point and impulse pipe should slope upwards.</p>		
3.01.02	<p>Impulse piping for air and flue gas shall slope upwards and instrument shall be installed above source point. If this requirement cannot be met special venting or drain provision shall be provided with vent & drain lines along with isolation valves and other accessories including drainpipes. This drain is to be connected to plant drain through open funnel also.</p>		
3.01.03	<p>All impulse piping shall be installed to permit free movement due to thermal expansion. Wherever required expansion loops shall be provided.</p>		
3.01.04	<p>Special accessories such as condensing pots/ reservoirs shall be provided and installed wherever required. In any case condensing pots shall be provided for all level measurements in steam and water services, all flow measurement in steam services and flow measurements water services above 120 Deg.C. For drum/ separator level measurement required balancing chamber shall be provided.</p>		
3.01.05	<p>Color coding of all impulse pipes shall be done by the bidder in line with the colour coding being followed for the parent pipes.</p>		
3.02.00	Instrument Air & Service Air Piping/ Tubing System		
3.02.01	<p>Instrument air & service air headers and their branches with all associated fittings & accessories shall be provided for giving supply to all consumers, as per the requirements. Air piping shall be installed always with a slope of over 1/20 to prevent accumulation of water within the pipe.</p>		
3.02.02	<p>Single and multi tubes shall run with the minimum number of changes in direction. Suitable identification tags shall be provided for easy checkup and for connections.</p>		
4.00.00	PIPING/TUBING SUPPORT		
4.01.00	<p>Impulse piping and sample piping shall be supported at an interval not exceeding 1.5 meters. Each pipe shall be supported individually using slotted angle mounted clamps with necessary fixtures. Tubing shall run in proper perforated trays with proper cover. Tubing shall be supported inside the trays by aluminium supports. Hangers and other fixtures required for support of piping and trays shall be provided, either by welding or by bolting on walls, ceilings and structures. Hanger clamps and other fastening hardware shall be of corrosion resistant metals and hot-dip galvanized.</p>		
<p>LARA STPP (2x800MW) / DARLIPALI STPP-I (2 x 800MW) / GAJMARA STPP-I (2x 800MW) / KUDGI STPP-I (3 x 800MW) / STEAM GENERATOR PACKAGE</p>	<p>TECHNICAL SPECIFICATION SECTION-VI BID DOC NO.: CS-9548/ 9549/ 9566/ 9573-102-2</p>	<p>PART - B SUB-SECTION-IV I-6 (PROCESS CONNECTION & PIPING)</p>	<p>PAGE 3 OF 6</p>

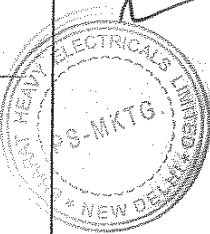

588

CLAUSE NO.	TECHNICAL REQUIREMENTS		
<p>5.00.00</p> <p>5.01.00</p> <p>5.01.01</p> <p>5.01.02</p> <p>5.02.00</p> <p>5.02.01</p> <p>5.03.00</p> <p>5.03.01</p>	<p>SHOP AND SITE TESTS</p> <p>General Requirements</p> <p>The equipment and work performed as per this Sub-section shall be subject to shop and site test as per requirements of Sub-section-Q (Quality Assurance & Inspection) other applicable clauses of this Sub-section and Employer approved quality assurance plan.</p> <p>Hydrostatic and pneumatic tests shall be performed on all pipes, tubing and systems and shall conform to ANSI B31.1.</p> <p>Hydrostatic Testing</p> <p>All instrument piping/ tubing shall be hydrostatically tested upon completion of erection. The test pressure shall be 1.5 times the maximum process pressure. The test shall be performed either with the testing of associated process piping or without the associated process piping (by closing the root valve). In both the cases the instrument shall be isolated by closing the shut-off valve.</p> <p>Air Testing</p> <p>All air headers & branch pipes shall be air tested by pressure decay method as per ANSI B31.1. Flexible hoses and short signal tubing shall be tested at normal pressure for leakage. Long signal tubing shall be tested by charging each tube with air at 2 kg/ sq. cm. through a bubbler sight glass. The boiler draft and vacuum piping shall be air tested by the same method as long signal tubing.</p>		
<p>6.00.00</p>	<p>LOCAL INSTRUMENT ENCLOSURE AND RACKS</p> <p>Transmitters, switches, devices, temperature transmitters etc. (except for all fuel oil applications which shall be mounted close to be tapping points) mounted in the field shall be suitably grouped together and mounted (i) local instruments enclosure in case of open areas of the plant like boiler area, etc. and (ii) In local instrument racks in case of covered areas. Gauges are to be mounted on a channel or a frame or a rack (Gauges shall not be mounted directly on process pipe). These local instrument enclosures and racks shall be furnished as per the actual requirements finalized during detailed engineering stage. The exact grouping of instruments in a particular instrument enclosure/instrument rack shall be as finalized during detailed engineering stage subject to Employer's approval.</p> <p>For mounting of PT/DPT/LT/FT, LIEs / LIRs shall be of three types depending on the number of transmitters located in it as elaborated in the typical GA of the LIE/LIR, drawing no. 0000-999-POI-A-064 (Sh Nos. 1 to 3 of 5).</p> <p>These dimensions and number of instruments indicated therein are only indicative and the exact dimensions along with the number of instruments shall be as finalized during detailed engineering stage without any price repercussions.</p> <p>The internal layout shall be such that the impulse piping/ blow down lines are accessible from back side of the enclosure / rack and the transmitters etc. are accessible from front side for easy maintenance. Bulkheads, especially designed to provide isolation from process line vibration shall be installed on instrument enclosures/racks to meet the process sensing line connection requirement.</p> <p>Vibration dampeners shall be installed for each enclosure / rack.</p>		
<p>LARA STPP (2x800MW) / DARLIPALI STPP-I (2 x 800MW) / GAJMARA STPP-I (2x 800MW) / KUDGI STPP-I (3 x 800MW) STEAM GENERATOR PACKAGE</p>	<p>TECHNICAL SPECIFICATION SECTION-VI BID DOC NO.: CS-9548/ 9549/ 9566/ 9573-102-2</p>	<p>PART - B SUB-SECTION-IV I-6 (PROCESS CONNECTION & PIPING)</p>	<p>PAGE 4 OF 6</p>

CLAUSE NO.	TECHNICAL REQUIREMENTS 		
	<p>The enclosures shall be constructed of 3 mm sheet plate and shall be of modular construction with one or more modules and two end assemblies bolted together to form an enclosure. Double inter locking doors shall be provided. The doors shall be the three-point locking type constructed of not less than 1.6 mm thick steel. Doors shall have concealed quick removal type pinned hinges and locking handles. Door locks shall accept the same key.</p> <p>Gaskets shall be used between all mating sections to achieve protection class of IP-55.</p> <p>The instrument racks shall be free standing type constructed of suitable 5 mm thick channel frame of steel and shall be provided with a canopy to protect the equipment mounted in racks from falling objects, water etc. The canopy shall not be less than 3 mm thick steel, and extended beyond the ends of the rack. Bulk heads, especially designed to provide isolation from process line vibration shall be provided. Exact fabrication details shall be as finalized during detailed engineering stage. The junction box for racks also shall conform to IP 55 protection class.</p> <p>Enclosures/racks shall be reinforced as required to ensure true surface and to provide adequate support for instruments and equipment mounted therein. Centre posts or any member which would reduce access shall not be provided.</p> <p>Each transmitter enclosure housing instruments requiring purge air for continuous air purging, shall be provided with common purge air header, redundant air filter regulators of sufficient capacity, required pressure gauges, valves, fittings, SS tubing and individual purge meters for each purge line etc. as required and indicated in Instrument Installation drawings enclosed herewith.</p> <p>A 15 mm NB service air header shall be furnished in each instrument enclosure housing air & flue gas and coal mill instruments. The header shall be furnished complete with a pressure regulating valve, pressure gauge, and quick disconnect connections. A hose for connecting each header to the draft instrument line four-way valves shall be furnished. The hose shall be self-storing nylon tubing having a burst pressure of 15 kg/sq. cm. The size of the hose shall be 1/2" minimum. The service air header shall originate at a bulkhead penetration or fitting located on one of the bulkhead plates.</p> <p>The contractor shall prepare the piping drawings and the general arrangement layout drawings for each of the enclosures and racks. Special attention shall be given in the piping layout to avoid air traps in liquid filled piping or water pockets in piping intended to be dry. Drawings shall indicate the arrangement of all equipment, piping, valves and fittings within, the enclosure/racks and shall be subject to Employer's approval.</p> <p>All liquid filled blow down lines, except those measuring vacuum shall be connected to a two inch header which is extended through one end of the enclosure and turned downward for directing the blow down into a drain. The material of the blow down header shall be carbon steel as per ASTM A 106 Gr. C.</p> <p>The Contractor shall submit to the Employer with his proposal a copy of his welding procedure specification together with proof of his compliance with the latest applicable welding ANSI code. Prior to any welding being performed, the Contractor shall submit the qualifications of the craftsmen who will perform the work.</p>		
LARA STPP (2x800MW) / DARLIPALI STPP-I (2 x 800MW) / GAJMARA STPP-I (2x 800MW) / KUDGI STPP-I (3 x 800MW) / STEAM GENERATOR PACKAGE	TECHNICAL SPECIFICATION SECTION-VI BID DOC NO.: CS-9548/ 9549/ 9566/ 9573-102-2	PART - B SUB-SECTION-IV I-6 (PROCESS CONNECTION & PIPING)	PAGE 5 OF 6



SUB-SECTION-IV: I7

INSTRUMENTATION AND POWER SUPPLY CABLE

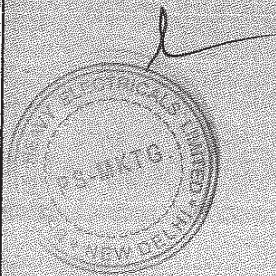

[Handwritten signature]

FOR

592

LARA SUPER THERMAL POWER PROJECT (2x800MW) /
DARLIPALI SUPER THERMAL POWER PROJECT -I (2 x 800MW) /
GAJMARA SUPER THERMAL POWER PROJECT -I (2x 800MW) /
KUDGI SUPER THERMAL POWER PROJECT -I (3 x 800MW)
STEAM GENERATOR PACKAGE

TECHNICAL SPECIFICATION
SECTION-VI
BID DOC NO.: CS-9548/ 9549/ 9566/ 9573-102-2

CLAUSE NO.	TECHNICAL REQUIREMENTS		
	INSTRUMENTATION AND POWER SUPPLY CABLE		
1.00.00	INSTRUMENTATION CABLE, POWER SUPPLY CABLE, INTERNAL WIRING AND ELECTRICAL FIELD CONSTRUCTION MATERIAL		
1.01.00	General Requirements		
1.01.01	All cables including special cables, internal wiring and electrical field construction material shall conform to this specification, Employer approved detail engineering drawings & documents and the latest edition of the relevant standards & guidelines. The Bidder shall furnish all material and services required for the completeness of the work identified in his scope as per this specification.		
1.01.01	The Contractor shall supply, erect, terminate and test all instrumentation cables for control and instrumentation equipment/devices/systems included under Contractor's scope as illustrated in the enclosed Drg. No. 0000-101/102-POI-A-021 and ensuring completeness of the control system.		
1.01.02	Any other application where it is felt that instrumentation cables are required due to system/operating condition requirements, are also to be provided by Contractor.		
1.01.03	Other type of cables like fiber optic/co-axial cables for system bus, cables for connection of peripherals etc. (under Contractor's scope) are also to be furnished by the Contractor.		
1.01.04	Contractor shall supply all cable erection and laying hardware from the main trunk routes like branch cable trays/sub-trays, supports, flexible conduits, cable glands, lugs, pull boxes etc. on as required basis for all the systems covered under this specification.		
1.01.05	Wherever the quantity has been defined as on as required basis, the same are to be furnished by contractor on as required basis within his quoted lump sump price without any further cost implication to the Employer.		
2.00.00	Specification of Instrumentation cable		
2.01.00	Common Requirements		
	S. No.	Property	Requirement
	1	Voltage grade	225 V (peak value)
	2.	Codes and standard	All instrumentation cables shall comply with VDE 0815, VDE 0207, Part 4, Part 5, Part 6, VDE 0816, VDE 0472, SEN 4241475, ANSI MC 96.1, IS-8784, IS-10810 (latest editions) and their amendments read along with this specification.
		Continuous operation suitability	At 70 deg. C for all types of cables, while 205 Deg C for Type-C cables.
		Progressive automatic on-line sequential marking of length in meters	To be provided at every one meter on outer sheath.
593			
LARA STPP (2x800MW) / DARLIPALI STPP-I (2 x 800MW) / GAJMARA STPP-I (2x 800MW) / KUDGI STPP-I (3 x 800MW) STEAM GENERATOR PACKAGE		TECHNICAL SPECIFICATION SECTION-VI BID DOC NO.: CS-9548/ 9549/ 9566/ 9573-102-2	PART - B SUB-SECTION-IV: I7 (INSTR. AND POWER SUPPLY CABLE)
			PAGE 1 OF 14

CLAUSE NO.	TECHNICAL REQUIREMENTS				
	5. Marking to read 'FRLS' 6. Allowable Tolerance on overall diameter 7. Variation in diameter 8. Ovality at any cross-section 9. Others	To be provided at every 5 meters on outer sheath except for Type-C cable. +/- 2 mm (maximum) over the declared value in data sheet Not more than 1.0 mm throughout the length of cable. Not more than 1.0 mm a) Durable marking at intervals not exceeding 625 mm shall include manufacturer's name, insulation material, conductor's size, number of pairs, voltage rating, type of cable, year of manufacturer to be provided. b) Cables shall be suitable for laying in conduits, ducts, trenches, racks and underground-buried installation c) Repaired cables shall not be acceptable.			
2.02.00	Specific Requirements				
	Specification Requirements	Type-A cable	Type-B cable	Type F & G cable	Type-C cable
	A. Conductors				
	Cross section area	(Same as T/C)		0.5 sq. mm	0.5 sq. mm.
	Conductor material	ANSI type KX	ANSI type SX	High conductivity Annealed bare copper	ANSI type KX
	Colour code	Yellow-Red	Black-Red	As per VDE-815	Yellow-Red
	Conductor Grade	As per ANSI MC 96.1		Electrolytic	As per ANSI MC 96.1
	No & dia of strands	7x0.3 mm (nom)			
	No. of Pairs	2	2	4,8,12,16,24,48	2
	Max. conductor resistance per Km (in ohm) at 20 deg. C	As per ANSI MC 96.1		73.4 (loop)	As per ANSI MC 96.1
LARA STPP (2x800MW) / DARLIPALI STPP-I (2 x 800MW) / GAJMARA STPP-I (2x 800MW) / KUDGI STPP-I (3 x 800MW) STEAM GENERATOR PACKAGE	TECHNICAL SPECIFICATION SECTION-VI BID DOC NO.: CS-9548/ 9549/ 9566/ 9573-102-2		PART - B SUB-SECTION-IV: I7 (INSTR. AND POWER SUPPLY CABLE)	PAGE 2 OF 14	

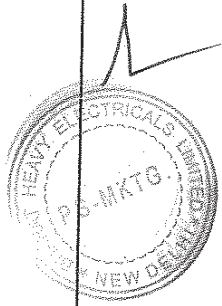
CLAUSE NO.	TECHNICAL REQUIREMENTS				
	Reference Standard	As per ANSI MC 96.1	VDE 0815		As per ANSI MC 96.1
	B. Insulation				
	Material	PVC type Y1 3			Teflon (i.e. extruded FEP)
	Thickness in mm (Min/Nom/Max)	0.25/0.3/0.35			0.4/0.50
	Volume Resistivity (Min) in ohm-cm	1 x 10 ¹⁴ at 20 deg. C & 1x10 ¹¹ at 70 deg. C.			---
	Voltage Rating	225 V peak operating voltage			
	Reference Standard	VDE 0207 Part 4			VDE 0207 Part 6 & ASTM D 2116.
	Core diameter above insulation	Suitable for cage clamp connector			
	C. Pairing & Twisting				
	Max. lay of pairs (mm)	50			
	Single layer of polyester numbered tape on each pair provided	Each core printed with	Yes		
	Unit formation of four pairs with printing of no. of Unit provided	N.A.	Yes		N.A.
	Conductor /pair identification as per VDE0815	N.A.	To be provided (color coding attached).		N.A.
	D. Shielding				
	Type of shielding	←----- Al-Mylar tape ----->			
	Individual pair shielding	No	To be provided for F-type cable	No	
	Minimum thickness of Individual pair shielding	No	28 micron	No	
 <p>LARA STPP (2x800MW) / DARLIPALI STPP-I (2 x 800MW) / GAJMARA STPP-I (2x 800MW) / KUDGI STPP-I (3 x 800MW) STEAM GENERATOR PACKAGE</p>	<p>595</p> <p>TECHNICAL SPECIFICATION SECTION-VI BID DOC NO.: CS-9548/ 9549/ 9566/ 9573-102-2</p>	<p>PART - B SUB-SECTION-IV: I7 (INSTR. AND POWER SUPPLY CABLE)</p>	<p>PAGE 3 OF 14</p>		

CLAUSE NO.	TECHNICAL REQUIREMENTS		
	Overall cable assembly shielding	To be provided	
	Minimum thickness of Overall cable assembly shielding	55 micron	
	Shielding coverage	100% with at least 20% overlap	
	Drain wire provided for individual shield	N.A. Yes (for F-type) 7-strand 20 AWG (0.51 mm ²) annealed Tin coated copper	N.A.
	Drain wire provided for overall shield	Yes. 7-strand 20 AWG (0.51 mm ²) annealed Tin coated copper	
	E. FILLERS		
	Non-hygroscopic, flame retardant	To be provided	
	F. Outer Sheath		
	Material	←--- Extruded PVC compound YM1 with---→ FRLS properties	Teflon (i.e. extruded FRP)
	Minimum Thickness at any point	1.8 mm	0.4 mm
	Nominal Thickness at any point	>1.8 mm	0.5 mm
	Color	Blue	
	Resistant to water, fungus, termite & rodent attack	Required	
	Oxygen index as per ASTMD-2863	not less than 29%	N.A.
	Temperature index as per ASTMD-2863	not less than 250 deg.C	N.A.
	Acid gas generation by weight as per IEC-60754-1	Maximum 20%	N.A.
LARA STPP (2x800MW) / DARLIPALI STPP-I (2 x 800MW) / GAJMARA STPP-I (2x 800MW) / KUDGI STPP-I (3 x 800MW) STEAM GENERATOR PACKAGE	TECHNICAL SPECIFICATION SECTION-VI BID DOC NO.: CS-9548/ 9549/ 9566/ 9573-102-2	PART - B SUB-SECTION-IV: 17 (INSTR. AND POWER SUPPLY CABLE)	PAGE 4 OF 14

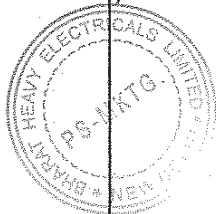

CLAUSE NO.	TECHNICAL REQUIREMENTS			एनटीपीसी NTPC
	Smoke Density Rating as per ASTMD-2843	Maximum 60% (defined as the average area under the curve when the results of smoke density test plotted on a curve indicating light absorption vs. time as per ASTMD-2843)		N.A.
	Reference standard	VDE207 Part 5		VDE207 Part 6 & ASTM D2116
	G. Electrical Parameters			
	Mutual Capacitance Between Conductors At 0.8 KHz (Max.)	200 nF/km	120 nF/km for F type 100 nF/km for G-type	200 nF/km
	Insulation Resistance (Min.)	100 M Ohm/Km		
	Cross Talk Figure (Min.) At 0.8 KHz	60 dB	60 dB	N.A.
	Characteristic Impedance (Max) At 1 KHz	N.A.	320 OHM FOR F-TYPE 340 OHM FOR G-TYPE	N.A.
	Attenuation Figure at 1 KHz (Max)	N.A.	1.2 db/km	N.A.
	H. Complete Cable			
	Complete Cable assembly	Shall pass Swedish Chimney test as per SEN-SS 4241475 class F3.		N.A.
	Flammability	Shall pass flammability as per IEEE-383 read in conjunction to this specification		N.A.
	I. Accessories			
	Cable accessories of flame retardant quality.	Yes. (Accessories such as harnessing components, markers, bedding, cable jointer, binding tape etc.)		
	J. Tests			
	Routine & Acceptance tests	Refer sub-section III E		
LARA STPP (2x800MW) / DARLIPALI STPP-I (2 x 800MW) / GAJMARA STPP-I (2x 800MW) / KUDGI STPP-I (3 x 800MW) STEAM GENERATOR PACKAGE		TECHNICAL SPECIFICATION SECTION-VI BID DOC NO.: CS-9548/ 9549/ 9566/ 9573-102-2	PART - B SUB-SECTION-IV: I7 (INSTR. AND POWER SUPPLY CABLE)	PAGE 5 OF 14

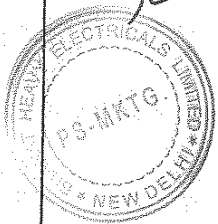

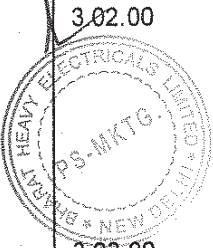

597

CLAUSE NO.	TECHNICAL REQUIREMENTS		
	<div style="text-align: right; border: 1px solid black; padding: 2px; width: fit-content; margin-bottom: 10px;">  </div> <p>Type tests Submission of type test results and certificate shall be acceptable provided the test has been conducted within last 5 years from the date of bid opening. In case the test is not conducted within last 5 years or spec requirements are not met, the same shall be conducted by contractor free of cost to Employer. Also, refer sub-section-IV:19 TYPE TEST REQUIREMENTS FOR C&I.</p> <p>K Cable Drum</p> <p>Type Non-returnable wooden drum (wooden drum to be constructed from seasoned wood free from defects with wood preservative applied to the entire drum) or steel drum.</p> <p>Outermost layer covered with waterproof paper Yes</p> <p>Painting Entire surface to be painted</p> <p>Length 1000 m + 5% for up to & including 12 pairs 500 m + 5% for above 12 pairs</p>		
3.00.00	SPECIFICATION OF OPTICAL FIBER CABLES (OFC)		
3.01.00	Optic Fiber cable shall be 4/8/12 core, galvanised corrugated steel taped armoured, fully water blocked with dielectric central member for outdoor/indoor application so as to prevent any physical damage. The cable shall have multiple single-mode or multi mode fibers on as required basis so as to avoid the usage of any repeaters. The core and cladding diameter shall be 9 +/- 1 micrometer and 125 +/- 1 micrometer respectively. The outer sheath shall have Flame Retardant, UV resistant properties and are to be identified with the manufacturer's name, year of manufacturer, progressive automatic sequential on-line marking of length in meters at every meter on outer sheath.		
3.02.00	The cable core shall have suitable characteristics and strengthening for prevention of damage during pulling viz. Steel central member, Loose buffer tube design, 4 fibers per buffer tube (minimum), Interstices and buffer tubes duly filled with Thixotropic jelly etc. The cable shall be suitable for a maximum tensile force of 2000 N during installation, and once installed, a tensile force of 1000 N minimum. The compressive strength of cable shall be 3000 N minimum & crush resistance 4000 N minimum. The operating temperature shall be - 20 deg. C to 70 deg. C		
3.03.00	All testing of the fiber optic cable being supplied shall be as per the relevant IEC, EIA and other international standards.		
3.04.00	Bidder to ensure that minimum 100% cores are kept as spares in all types of optical fibre cables.		
3.05.00	Cables shall be suitable for laying in conduits, ducts, trenches, racks and under ground buried installation.		
3.06.00	Spliced / Repaired cables are not acceptable.		
3.07.00	Penetration of water resistance and impact resistance shall be as per IEC standard.		
LARA STPP (2x800MW) / DARLIPALI STPP-I (2 x 800MW) / GAJMARA STPP-I (2x 800MW) / KUDGI STPP-I (3 x 800MW) / STEAM GENERATOR PACKAGE	TECHNICAL SPECIFICATION SECTION-VI BID DOC NO.: CS-9548/ 9549/ 9566/ 9573-102-2	PART - B SUB-SECTION-IV: 17 (INSTR. AND POWER SUPPLY CABLE)	PAGE 6 OF 14

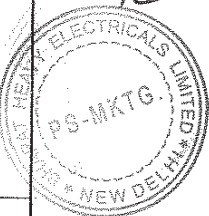

CLAUSE NO.	TECHNICAL REQUIREMENTS																																																					
4.00.00	<p>SPECIFICATION OF POWER SUPPLY CABLES</p> <p>For technical specification, testing requirements etc, refer relevant subsections of this specification.</p>																																																					
5.00.00	<p>INSTRUMENTATION CABLE INTERCONNECTION AND TERMINATION PHILOSOPHY</p> <p>The cable interconnection philosophy to be adopted shall be such that extensive grouping of signals by large scale use of field mounted Group Junction Boxes (JBs) at strategic locations (where large concentration of signals are available, e.g. valves limit & torque switches, switchgear) is done and consequently cable with higher number of pairs are extensively used. The details of termination to be followed are mentioned in the given Table A.</p> <p style="text-align: center;">TABLE A: CABLE TERMINATION TO BE FOLLOWED</p> <table border="1" data-bbox="402 682 1437 1885"> <thead> <tr> <th data-bbox="402 682 625 808">Application</th> <th data-bbox="625 682 901 808">Type Of Termination</th> <th colspan="2" data-bbox="901 682 1437 808">Type Of</th> <th data-bbox="1437 682 1461 808">Cable</th> </tr> <tr> <th data-bbox="402 808 625 840">FROM (A)</th> <th data-bbox="625 808 901 840">TO (B)</th> <th data-bbox="901 808 1079 840">END A</th> <th data-bbox="1079 808 1437 840">END B</th> <th data-bbox="1437 808 1461 840"></th> </tr> </thead> <tbody> <tr> <td data-bbox="402 840 625 976">Valves/dampers drives (Integral Junction box)</td> <td data-bbox="625 840 901 976">Marshalling cubicle/ Marshalling cum termination Cubicle/local group JB</td> <td data-bbox="901 840 1079 976">Plug in connector</td> <td data-bbox="1079 840 1437 976">Posts mount cage clamp type.</td> <td data-bbox="1437 840 1461 976">G</td> </tr> <tr> <td data-bbox="402 976 625 1113">Transmitters, Process Actuated switches mounted in LIE/LIR</td> <td data-bbox="625 976 901 1113">Integral Junction box of LIE/LIR</td> <td data-bbox="901 976 1079 1113">Plug in connector</td> <td data-bbox="1079 976 1437 1113">Cage clamp (Rail mount) type.</td> <td data-bbox="1437 976 1461 1113">F,G</td> </tr> <tr> <td data-bbox="402 1113 625 1228">RTD heads</td> <td data-bbox="625 1113 901 1228">Local junction box</td> <td data-bbox="901 1113 1079 1228">Plug in connector</td> <td data-bbox="1079 1113 1437 1228">Cage clamp (Rail mount) type.</td> <td data-bbox="1437 1113 1461 1228">F</td> </tr> <tr> <td data-bbox="402 1228 625 1354">Thermocouple</td> <td data-bbox="625 1228 901 1354">CJC Box (if applicable)</td> <td data-bbox="901 1228 1079 1354">Plug in connector</td> <td data-bbox="1079 1228 1437 1354">Cage clamp (Rail mount) type.</td> <td data-bbox="1437 1228 1461 1354">A,B,C*</td> </tr> <tr> <td data-bbox="402 1354 625 1470">Other Field Mounted Instrument</td> <td data-bbox="625 1354 901 1470">Local JB/Group JB</td> <td data-bbox="901 1354 1079 1470">Plug in connector</td> <td data-bbox="1079 1354 1437 1470">Screwed, Cage clamp (Rail mount) type</td> <td data-bbox="1437 1354 1461 1470">F,G</td> </tr> <tr> <td data-bbox="402 1470 625 1554">RTD</td> <td data-bbox="625 1470 901 1554">Temperature transmitter</td> <td data-bbox="901 1470 1079 1554">Plug in connector</td> <td data-bbox="1079 1470 1437 1554">Screwed, Cage clamp type</td> <td data-bbox="1437 1470 1461 1554">F</td> </tr> <tr> <td data-bbox="402 1554 625 1648">Thermocouple</td> <td data-bbox="625 1554 901 1648">Temperature transmitter</td> <td data-bbox="901 1554 1079 1648">Plug in connector</td> <td data-bbox="1079 1554 1437 1648">Screwed, Cage clamp type</td> <td data-bbox="1437 1554 1461 1648">A,B,C*</td> </tr> <tr> <td data-bbox="402 1648 625 1885">Local Junction box, Temperature Transmitter, Int. Junction box of LIE/ LIR/Group JB/ MCC/SWGR</td> <td data-bbox="625 1648 901 1885">Group JB</td> <td data-bbox="901 1648 1079 1885">Cage clamp (Rail mount) type.</td> <td data-bbox="1079 1648 1437 1885">Cage clamp (Rail mount) type.</td> <td data-bbox="1437 1648 1461 1885">F,G</td> </tr> </tbody> </table>				Application	Type Of Termination	Type Of		Cable	FROM (A)	TO (B)	END A	END B		Valves/dampers drives (Integral Junction box)	Marshalling cubicle/ Marshalling cum termination Cubicle/local group JB	Plug in connector	Posts mount cage clamp type.	G	Transmitters, Process Actuated switches mounted in LIE/LIR	Integral Junction box of LIE/LIR	Plug in connector	Cage clamp (Rail mount) type.	F,G	RTD heads	Local junction box	Plug in connector	Cage clamp (Rail mount) type.	F	Thermocouple	CJC Box (if applicable)	Plug in connector	Cage clamp (Rail mount) type.	A,B,C*	Other Field Mounted Instrument	Local JB/Group JB	Plug in connector	Screwed, Cage clamp (Rail mount) type	F,G	RTD	Temperature transmitter	Plug in connector	Screwed, Cage clamp type	F	Thermocouple	Temperature transmitter	Plug in connector	Screwed, Cage clamp type	A,B,C*	Local Junction box, Temperature Transmitter, Int. Junction box of LIE/ LIR/Group JB/ MCC/SWGR	Group JB	Cage clamp (Rail mount) type.	Cage clamp (Rail mount) type.	F,G
Application	Type Of Termination	Type Of		Cable																																																		
FROM (A)	TO (B)	END A	END B																																																			
Valves/dampers drives (Integral Junction box)	Marshalling cubicle/ Marshalling cum termination Cubicle/local group JB	Plug in connector	Posts mount cage clamp type.	G																																																		
Transmitters, Process Actuated switches mounted in LIE/LIR	Integral Junction box of LIE/LIR	Plug in connector	Cage clamp (Rail mount) type.	F,G																																																		
RTD heads	Local junction box	Plug in connector	Cage clamp (Rail mount) type.	F																																																		
Thermocouple	CJC Box (if applicable)	Plug in connector	Cage clamp (Rail mount) type.	A,B,C*																																																		
Other Field Mounted Instrument	Local JB/Group JB	Plug in connector	Screwed, Cage clamp (Rail mount) type	F,G																																																		
RTD	Temperature transmitter	Plug in connector	Screwed, Cage clamp type	F																																																		
Thermocouple	Temperature transmitter	Plug in connector	Screwed, Cage clamp type	A,B,C*																																																		
Local Junction box, Temperature Transmitter, Int. Junction box of LIE/ LIR/Group JB/ MCC/SWGR	Group JB	Cage clamp (Rail mount) type.	Cage clamp (Rail mount) type.	F,G																																																		
LARA STPP (2x800MW) / DARLIPALI STPP-I (2 x 800MW) / GAJMAR STPP-I (2x 800MW) / KUDGI STPP-I (3 x 800MW) STEAM GENERATOR PACKAGE	<p style="text-align: center;">599</p> <p style="text-align: center;">TECHNICAL SPECIFICATION SECTION-VI BID DOC NO.: CS-9548/ 9549/ 9566/ 9573-102-2</p>	PART - B SUB-SECTION-IV: 17 (INSTR. AND POWER SUPPLY CABLE)	PAGE 7 OF 14																																																			



CLAUSE NO.	TECHNICAL REQUIREMENTS				
	Application	Type Of Termination	Type Of	Cable	
	FROM (A)	TO (B)	END A	END B	
	Local Junction box, Temperature Transmitter, Int. Junction box of LIE/ LIR/Group JB/ MCC/SWGR	Marshalling Cubicle/ Marshalling cum Termination Cabinet	Cage clamp (Rail mount) type.	Posts mount cage clamp type.	F,G
	Marshalling cubicle/ Termination Cabinet	Electronic system cabinet	Cage clamp Post mounted type.	Plug in connector/ Other System as per manufacturer's Standard	Internal wiring
	Marshalling/ Termination System Cabinets	UCD mounted equipments	Post mount cage clamp type.	Plug in connector/ Cage clamp type (rail mounted).	F,G (with plug-in connector at one end)
	DDCMIS/PLC cabinets	PC, Printers etc.	Plug in connector	Plug in connector	Mfr.'s Standard
Notes	<ol style="list-style-type: none"> Normally 10% spare cores shall be provided when the numbers of pairs of cables are more than four pairs except for pre-fabricated cables which shall be as per manufacturer's standard. For analog signals, individual pair shielding & overall shielding & for Binary signals, only overall shielding of instrumentation cables shall be provided. Also refer Drg. 0000-101/102-POI-A-021. *For high temperature applications only. Instrument Cabling for instruments/equipments covered under subsection-IV:13 (MAIN EQP INST SYS) shall be as per manufacturer's standard. 				
6.00.00	TERMINAL BLOCKS				
6.01.00	<p>All terminal blocks shall be rail mounted/post mounted, cage clamp type with high quality non-flammable insulating material of melamine suitable for working temperature of 105 deg.C. The terminal blocks in field mounted junction boxes, temperature transmitters, instrument enclosures/racks, etc., shall be suitable for cage clamp connections. The terminal blocks in Control Equipment Room logic/termination/marshalling cubicles shall be suitable for post mounted cage clamp connection at the field input end. The terminal blocks for DDCMIS input/output connections from/to SWGR/MCC, Actuators with Integral Starter (for coupling</p>				
LARA STPP (2x800MW) / DARLIPALI STPP-I (2 x 800MW) / GAJMARA STPP-I (2x 800MW) / KUDGI STPP-I (3 x 800MW) STEAM GENERATOR PACKAGE	TECHNICAL SPECIFICATION SECTION-VI BID DOC NO.: CS-9548/ 9549/ 9566/ 9573-102-2	PART - B SUB-SECTION-IV: 17 (INSTR. AND POWER SUPPLY CABLE)	PAGE 8 OF 14		

CLAUSE NO.	<div style="text-align: right;">  </div> TECHNICAL REQUIREMENTS		
	relays and check back signals of 11 kV and 3.3 kV auxiliaries, LT drives/valves & dampers/solenoids, CT & VT, etc.) shall be provided with built in test and disconnect facilities complete with plug, slide clamp, test socket etc. The exact type of terminal blocks to be provided by the Bidder and the technical details of the same including width etc. shall be subject to Employer's approval.		
6.02.00	All the terminal blocks shall be provided complete with all required accessories including assembly rail, locking pin and section, end brackets, partitions, small partitions, test plug bolts and test plug (as specified above for SWGR connections) transparent covers, support brackets, distance sleeves, warning label, marking, etc.		
6.03.00	The marking on terminal strips shall correspond to the terminal numbering on wiring diagrams. At least 20% spare unused terminals shall be provided everywhere including local junction boxes, instrument racks/enclosures, termination/marshalling cabinets, etc. All terminal blocks shall be numbered for identification and grouped according to the function. Engraved labels shall be provided on the terminal blocks.		
6.04.00	For terminating each process actuated switches, drive actuators, control valves, Thermocouple, RTD, etc. in Local Junction Boxes, etc, refer Drg no. 0000-999-POI-A-065.		
6.05.00	The terminal blocks shall be arranged with at least 100 mm clearance between two sets of terminal blocks and between terminal blocks and junction box walls.		
6.06.00	For ensuring proper connections, Bidder shall provide suitable accessories, along with insulation sleeves. The exact connecting accessory shall be finalized as per application during detail engineering stage subject to Employer's approval without any cost repercussions.		
6.07.00	Internal wiring in factory pre-wired electronic equipment cabinets may be installed according to the Bidder's standard as to wire size and method of termination or internal equipment. Terminal blocks for connection of external circuits into factory prewired electronic equipment cabinets shall meet all the requirements as specified above.		
7.00.00	INTERNAL PANELS/ SYSTEM CABINETS WIRING		
7.01.00	Internal panel/cabinet wiring shall be of multi-stranded copper conductor with FRLS PVC insulation without shield and outer sheath meeting the requirements of VDE 0815.		
7.02.00	Wiring to door mounted devices shall be done by 19 strand copper wire provided with adequate loop lengths of hinge wire so that multiple door opening shall not cause fatigue breaking of the conductor.		
7.03.00	All internal wires shall be provided with tag and identification nos. etched on tightly fitted ferrules at both ends in Employer's approved format. All wires directly connected to trip devices shall be distinguished by one additional red color ferrule.		
7.04.00	All external connection shall be made with one wire per termination point. Wires shall not be tapped or spliced between terminal points.		
7.05.00	All floor slots of desk/panels/cabinets used for cable entrance shall be provided with removable gasketed gland plates and sealing material. Split type grommets shall be used for prefabricated cables.		
7.06.00	All the special tools as may be required for solder less connections shall be provided by Bidder.		
LARA STPP (2x800MW) / DARLIPALI STPP-I (2 x 800MW) / GAJMARA STPP-I (2x 800MW) / KUDGI STPP-I (3 x 800MW) STEAM GENERATOR PACKAGE	TECHNICAL SPECIFICATION SECTION-VI BID DOC NO.: CS-9548/ 9549/ 9566/ 9573-102-2	PART - B SUB-SECTION-IV: 17 (INSTR. AND POWER SUPPLY CABLE)	PAGE 9 OF 14

CLAUSE NO.	TECHNICAL REQUIREMENTS									
7.07.00	<p>Wire sizes to be utilized for internal wiring.</p> <p>(i) Current (4-20 mA), low voltage signals (48V); Ammeter/Voltmeter circuit, control switches etc. for electrical system. 0.5 Sq.mm.</p> <p>(ii) Power supply and internal illumination. 2.5Sq.mm. minimum (shall be as per load requirement.)</p>									
8.00.00	INSTRUMENTATION CABLE INSTALLATION AND ROUTING									
8.01.00	All cables assigned to a particular duct/conduit shall be grouped and pulled in simultaneously using cable grips and suitable lubricants. Cables removed from one duct/conduit shall not be reused without approval of Employer.									
8.02.00	<p>Cables shall be segregated as per IEEE Std.-422. In vertically stacked trays, the higher voltage cable shall be in higher position and instrumentation cable shall be in bottom tier of the tray stack. The distance between instrumentation cables and those of other system shall be as follows:</p> <table border="0"> <tr> <td>From 11 kV/6.6 kV/3.3 kV tray system</td> <td>-</td> <td>914 mm</td> </tr> <tr> <td>From 415V tray system</td> <td>-</td> <td>610 mm</td> </tr> <tr> <td>From control cable tray system</td> <td>-</td> <td>305 mm</td> </tr> </table>	From 11 kV/6.6 kV/3.3 kV tray system	-	914 mm	From 415V tray system	-	610 mm	From control cable tray system	-	305 mm
From 11 kV/6.6 kV/3.3 kV tray system	-	914 mm								
From 415V tray system	-	610 mm								
From control cable tray system	-	305 mm								
8.03.00	Cables shall terminate in the enclosure through cable glands. All cable glands shall be properly gasketed. Fire proof sealing (to prevent ingress of dust entry and propagation of fire) shall be provided for all floor slots used for cable entrance. Compression cable glands (double for armoured and single for other cables) shall be provided.									
8.04.00	All cables shall be identified by tag. Nos. provided in Employer's approved format at both the ends as well as at an interval of 5 meters.									
8.05.00	Line voltage drop due to high resistance splices, terminal contacts, insulation resistance at terminal block, very long transmission line etc. shall be reduced as far as practicable.									
8.06.00	The cables emanating from redundant equipment/devices shall be routed through different paths. The above segregation of cables & wiring for redundant equipments/devices shall be in accordance with IEEE-Std-422.									
9.00.00	CABLE LAYING AND ACCESSORIES									
9.01.00	<p>CABLE LAYING</p> <p>1 Cables shall be laid strictly in line with cable schedule.</p> <p>2 Identification tags for cables.</p> <p>Indelible tags to be provided at all terminations, on both sides of wall or floor crossing, on each conduit/duct/pipe entry/exit, and at every 20 m in cable trench/tray.</p>									
<p>LARA STPP (2x800MW) / DARLIPALI STPP-I (2 x 800MW) / GAJMARA STPP-I (2x 800MW) / KUDGI STPP-I (3 x 800MW) STEAM GENERATOR PACKAGE</p>	<p>TECHNICAL SPECIFICATION SECTION-VI BID DOC NO.: CS-9548/ 9549/ 9566/ 9573-102-2</p>	<p>PART - B SUB-SECTION-IV: 17 (INSTR. AND POWER SUPPLY CABLE)</p>	<p>PAGE 10 OF 14</p>							

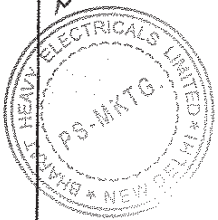

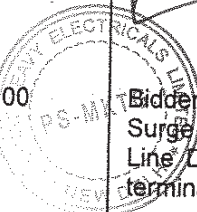
CLAUSE NO.	TECHNICAL REQUIREMENTS		
<p>9.02.00</p> <p></p>	<p>3 Cable tray numbering and marking. To be provided at every 10m and at each end of cable way & branch connection.</p> <p>4 Joints for less than 250 Meters run of cable shall not be permitted.</p> <p>5 Buried cable protection With concrete slabs; Route markers at every 20 Meters along the route & at every bend.</p> <p>6 Road Crossings Cables to pass through buried high density PE pipes encased in PCC. At least 300 mm clearance shall be provided between</p> <ul style="list-style-type: none"> - HT power & LT power cables, - LT power & LT control cables - LT control & instrumentation cables, <p>Spacing between cables of same voltage grade shall be in accordance with the de-rating criteria adopted for cable sizing.</p> <p>7 Segregation (physical isolation to prevent fire jumping)</p> <p>a All cable associated with the unit shall be segregated from cables of other Units.</p> <p>b Interplant cables of station auxiliaries and unit critical drives shall be segregated in such a way that not more than half of the drives are lost in case of single incident of fire.</p> <p>8 Cable clamping All cables laid on trays shall be neatly dressed up & suitably clamped/tied to the tray. For cables in trefoil formation, trefoil clamps shall be provided.</p> <p>9 Optical fiber cables inside conduit shall be laid on cable trays wherever available and feasible. In areas where the same are required to be buried, the same shall be buried in separate trench approx. 1.6 meter depth, to be laid in 2" GI/rodent proof HDPE conduits covered with sand, brick and soil along the pipe line route;</p> <p>While crossing roads - to be laid in GI/rodent proof HDPE conduits with sand filling at bottom and sand, soil filling at top with cement concrete;</p> <p>While crossing canals/river- to be laid in GI/rodent proof HDPE conduits within hume pipe.</p> <p>Bidder shall supply and install all cable accessories and fittings like Light Interface Units, Surge suppressors, Opto isolators, Interface Converters, Fibre Optic Card Cage, Fibre Optic Line Driver, Repeater / Modem (for Optical Fibre Cables), cable glands, grommets, lugs, termination kits etc. on as required basis.</p> <p style="text-align: center;">603</p>		
<p>LARA STPP (2x800MW) / DARLIPALI STPP-I (2 x 800MW) / GAJMARA STPP-I (2x 800MW) / KUDGI STPP-I (3 x 800MW) STEAM GENERATOR PACKAGE</p>	<p>TECHNICAL SPECIFICATION SECTION-VI BID DOC NO.: CS-9548/ 9549/ 9566/ 9573-102-2</p>	<p>PART - B SUB-SECTION-IV: 17 (INSTR. AND POWER SUPPLY CABLE)</p>	<p>PAGE 11 OF 14</p>

CLAUSE NO.	TECHNICAL REQUIREMENTS		
9.03.00	Bidder shall furnish two completely new sets of cable termination kits like Crimping tools, etc., which are required for maintenance of the system as per the type of termination used.		
9.04.00	Cables, which terminate in cabinets of draw out sections shall have sufficient cable coiled in the bottom of the cabinet to permit full withdrawal of draw out sections without disconnecting the cables. When prefabricated cables with factory connectors on both ends are longer than required, the excess cable shall be coiled in the bottom of one or both termination cabinets.		
9.05.00	No splices shall be made in conductors for instrument and control circuits except where required at connections to devices equipped with factory installed pigtails. Such splices shall be made only in approved splicing boxes of fitting with removable cover. The splices shall be made with sufficient slack left in the wires to permit withdrawal of the splice from the splicing box for ease of future disconnection of the splices. All exposed conductor or connector surfaces shall be covered with a minimum of three half-lapped layers of all weather vinyl plastic electrical tape. Taping shall extend a minimum of two cable diameters over the cable jacket and a similar distance over the other insulation or connections requiring insulation.		
9.06.00	The Bidder shall be responsible for proper grounding of all equipment under C&I package. Further, proper termination of cable shields shall be verified and the grounding of the same shall be coordinated so as to achieve grounding of all instrumentation cable shields at same potential. This shall be completed prior to system tests. All the cables etc. required for grounding of all equipments supplied under this package are to be supplied by the Bidder.		
9.07.00	The Contractor shall take full care while laying / installing cables as recommended by cable manufacturers regarding pulling tensions and cable bends. Cables damaged in any way during installation shall be replaced at the expense of the Contractor.		
10.00.00	<p>FIELD MOUNTED LOCAL JUNCTION BOXES</p> <p>(i) No. of ways 12/24/36/48/64/72/96/128 with 20% spares terminals.</p> <p>(ii) Material and Thickness 4mm thick Fiberglass Reinforced Polyester (FRP).</p> <p>(iii) Type Door gasket shall be of synthetic rubber.</p> <p>(iv) Mounting clamps and accessories Suitable for mounting on walls, columns, structures etc. The brackets, bolts, nuts, screws, glands and lugs required for erection shall be of brass, included in Bidders scope of supply.</p> <p>(v) Type of terminal blocks Rail mounted cage-clamp type suitable for conductor size upto 2.5 mm². A M6 earthing stud shall be provided.</p> <p>(vi) Protection Class IP: 55 minimum for indoor & IP-65 minimum for outdoor applications.</p> <p>(vii) Grounding To be provided.</p> <p>(viii) Color To be decided during detailed engineering & subject to Employer's approval.</p>		
<p>LARA STPP (2x800MW) / DARLIPALI STPP-I (2 x 800MW) / GAJMARA STPP-I (2x 800MW) / KUDGI STPP-I (3 x 800MW) STEAM GENERATOR PACKAGE</p>	<p>TECHNICAL SPECIFICATION SECTION-VI BID DOC NO.: CS-9548/ 9549/ 9566/ 9573-102-2</p>	<p>PART - B SUB-SECTION-IV: I7 (INSTR. AND POWER SUPPLY CABLE)</p>	<p>PAGE 12 OF 14</p>

