



Bharat Heavy Electricals Limited

ELECTRONICS DIVISION,
POST BOX No: 2606, MYSORE ROAD, BANGALORE-560026.

Tender Ref. No.: BHEL/EDN/MM/PR/001

DATED 26.07.2013

CORRIGENDUM

The earlier specified due date in respect of this office tender/ RFQ No. KBS0000273 DTD. 13/07/2013 for Turbine Supervisory & Vibration Monitoring System is hereby extended to date 26th August 2013 from 05th August 2013. The other terms and conditions published earlier will remain unchanged.

Due date for Tender opening: 26th Aug 2013 by 13.00 Hrs.
Bidders are requested to ensure submission of sealed Tenders on or before 13.00 Hrs of 26th Aug 2013.

PI note: 3 reference Drawings, which are part of Tender Specifications, missed out earlier are attached herewith.

The tender specifications with tender terms & conditions are available in websites, www.bhel.com, www.bheledn.com, & www.tenders.gov.in. All corrigenda, addenda, amendments, time extension, clarification, etc. to the tender will be hosted on website www.bhel.com & www.bheledn.com only. Bidders should regularly visit websites to keep themselves updated.

AGM / CE-MM-PR



A4 - 11

PURCHASE SPECIFICATION
FOR
TURBINE SUPERVISORY SYSTEM

ANNEXURE-01

REV.NO. 02

PAGE 01 OF 01

COPY RIGHT AND CONFIDENTIAL

The information on this document is the property of Bharat Heavy Electricals Limited. It must not be used directly or indirectly in anyway detrimental to the interest to the Company.

TYPICAL BEARING ARRANGEMENT OF TG SET FOR $\leq 500\text{MW}$

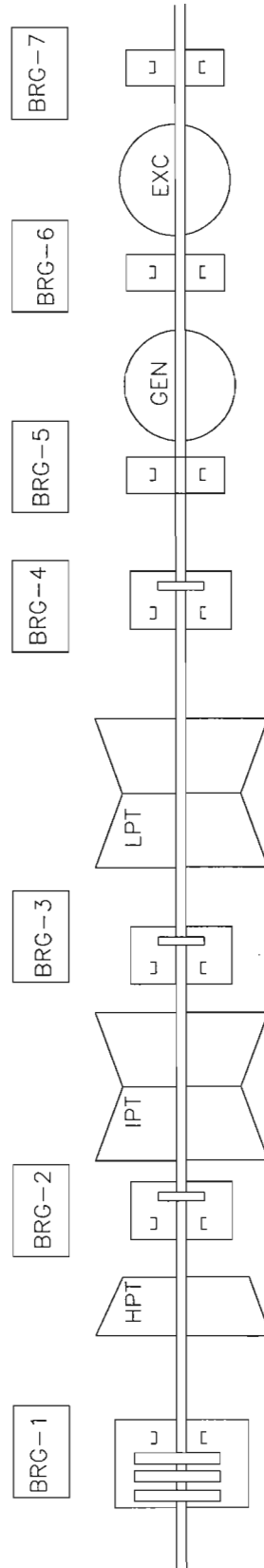

NOTES:-

1. BEARINGS ARE OF HYDRODYNAMIC JOURNAL TYPE
2. BRG-2 IS COMBINED THRUST & JOURNAL BEARING
3. RATED SPEED IS 3000 RPM AND POWER IS 500MW



PURCHASE SPECIFICATION
FOR
TURBINE SUPERVISORY SYSTEM

ANNEXURE-2

REV.NO.03

PAGE 01 OF 01

COPY RIGHT AND CONFIDENTIAL
The information on this document is the property of Bharat Heavy Electricals Limited.
It must not be used directly or indirectly in anyway detrimental to the interest to the Company.

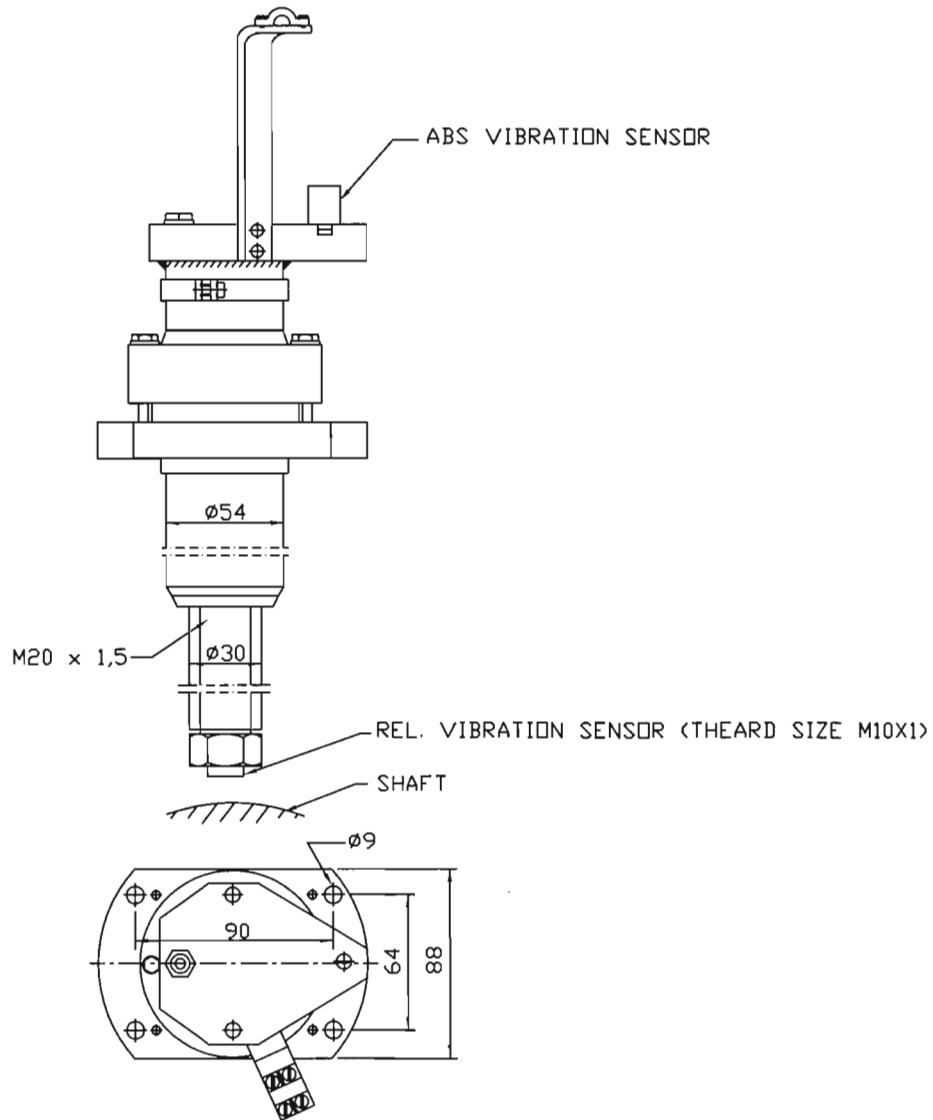

DUAL PROBE HOUSING



**PURCHASE SPECIFICATION FOR
TSS+VMS + ANALYSIS AND
DIAGNOSTICS**

ANNEXURE-3

REV. NO. 00

A4 - 10

PAGE 01 OF 1

MOUNTING BRACKET FOR BEARING 5 & 6

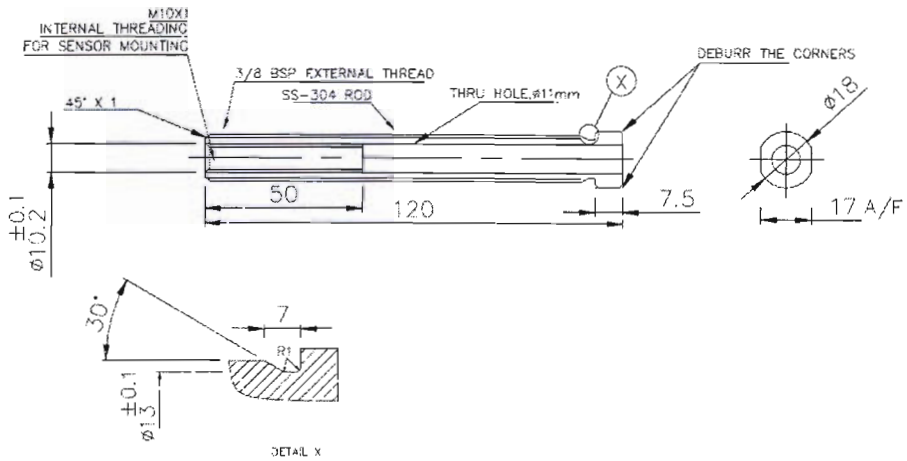

MOUNTING ARRANGEMENT FOR BEARING 5&6

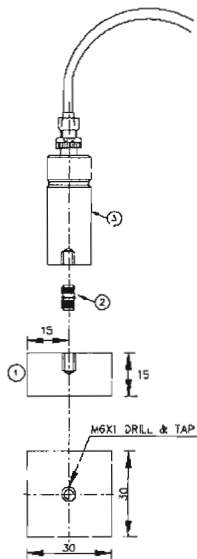

**SENSOR MOUNTING
INSTALLATION DETAILS FOR BRG. 5 & 6**

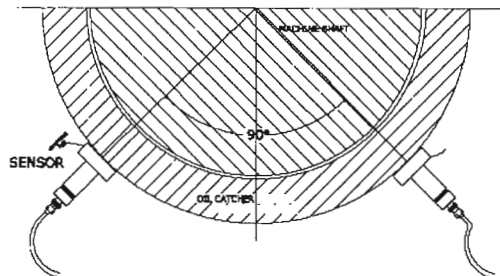

MMS/CK/MDL - 225
MOUNTING PAD

COPY RIGHT AND CONFIDENTIAL

The information on this document is the property of Bharat Heavy Electrical Limited. It must not be used directly or indirectly in anyway detrimental to the interest of the company.