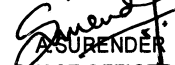

		BHARAT HEAVY ELECTRICALS LIMITED [A Government of India Undertaking] Ramachandrapuram, Hyderabad, 502032, A.P. India Phone 040-23184526, 23182322 FAX:040-23021910, 1954		भारत हेवी इलेक्ट्रिकल्स लिमिटेड (भारत सरकार का उपक्रम) रामचन्द्रपुरम, हैदराबाद, 502032 आंध्र प्रदेश, भारत		RFQ NO :		PURCHASE DEPARTMENT ENQUIRY क्रय विभाग जांच (ई मेल : tenderbox@bhelhyd.co.in)		SHEET:1 OF :2	
HY17001 C REV.NO.0		Phone 091-40-23184526 091-40-23182322		FAX : 091-40-23021910 091-40-23021954		E-Mail: tenderbox@bhelhyd.co.in		PURCHASE DEPARTMENT			
Enq/Collective Number :D3A1059396			Enq.Date : 31.03.2015		No.Of Items : 06		DUE DATE OF QUOTATION : 21.04.2015				
Supplier's Copy			Please submit your lowest quotation in sealed cover superscribed with Enquiry No./Collective No.(RFQ No) and due date subject to our terms and conditions attached ,for the materials mentioned below.Your offer has to reach us onor before due date by 10.00 Hours (IST) and will be opened at 14.00 Hours.(IST).If our Enquiry No./Collective No.(RFQ No) and tender due date are not super scribed on the tender cover , your offer shall be summarily rejected.Whosoever desires to send offers on their own risk (complete in all respects) via e-mail have to send offers to the common e-mail address : tenderbox@bhelhyd.co.in . Incomplete offers and late offers will not be considered.								
SL NO	Purchase Req.no	Item no	Material Code	Drg no - Ver , Rev & Spec - Ver , Rev	Description	Unit	Qty	Delivery Date	Schedule Qty		
1	8000059396	10	HE9718586857	31750102320-01, HE51173-NA,10	SS SMLS U TUBES (OD15.875X8500LL)	EA	7,400.000	30.11.2015	1,850.000		
		20						30.11.2015	1,850.000		
	8000059762	10						28.02.2016	1,850.000		
		20						28.02.2016	1,850.000		
2	8000059396	30	HE9718586865	31750102320-02, HE51173-NA,10	SS SMLS U TUBES (OD15.875X11200LL)	EA	7,400.000	30.11.2015	1,850.000		
		40						30.11.2015	1,850.000		
	8000059762	30						28.02.2016	1,850.000		
		40						28.02.2016	1,850.000		
3	8000059396	50	HE9718586873	31750102320-03, HE51173-NA,10	SS SMLS U TUBES (OD15.875X8000LL)	EA	7,400.000	30.11.2015	1,850.000		
		60						30.11.2015	1,850.000		
						TEST CERTIFICATE REQD: Y GUARANTEE REQ : Y SAMPLE REQD : N BID TYPE : TWO PART		For and on-behalf of Bharat Heavy Electricals Limited.  ASURENDER PURCHASE OFFICER / PUR (HE&F)			

		BHARAT HEAVY ELECTRICALS LIMITED [A Government of India Undertaking] Ramachandrapuram, Hyderabad, 502032, A.P. India Phone 040-23184526, 23182322 FAX:040-23021910, 1954		भारत हेवी इलेक्ट्रिकल्स लिमिटेड (भारत सरकार का उपक्रम) रामचन्द्रपुरम, हैदराबाद, 502032 आंध्र प्रदेश, भारत		RFQ NO :		PURCHASE DEPARTMENT ENQUIRY क्रय विभाग जांच (ई मेल : tenderbox@bhelhyd.co.in)		SHEET:2 OF :2	
HY17001 C REV.NO.0		Phone 091-40-23184526 091-40-23182322		FAX : 091-40-23021910 091-40-23021954		E-Mail: tenderbox@bhelhyd.co.in		PURCHASE DEPARTMENT			
			Eng/Collective Number :D3A1O59396		Eng.Date : 31.03.2015		No.Of Items : 06		DUE DATE OF QUOTATION : 21.04.2015		
Supplier's Copy			Please submit your lowest quotation in sealed cover superscribed with Enquiry No./Collective No.(RFQ No) and due date subject to our terms and conditions attached ,for the materials mentioned below.Your offer has to reach us onor before due date by 10.00 Hours (IST) and will be opened at 14.00 Hours.(IST).If our Enquiry No./Collective No.(RFQ No) and tender due date are not super scribed on the tender cover , your offer shall be summarily rejected.Whosoever desires to send offers on their own risk (complete in all respects) via e-mail have to send offers to the common e-mail address : tenderbox@bhelhyd.co.in . Incomplete offers and late offers will not be considered.								
SL NO	Purchase Req.no	Item no	Material Code	Org no - Ver , Rev & Spec - Ver , Rev	Description	Unit	Qty	Delivery Date	Schedule Qty		
	8000059762	50						28.02.2016	1,850.000		
		60						28.02.2016	1,850.000		
4	8000059838	10	HE9718583033	31750102322-01, HE51173-NA,10	SS SMLS U TUBES(OD15.875X7800LL)	EA	6,040.000	30.12.2015	3,020.000		
		20						30.01.2016	3,020.000		
5	8000059838	30	HE9718583041	31750102322-02, HE51173-NA,10	SS SMLS U TUBES(OD15.875X11200LL)	EA	6,040.000	30.12.2015	3,020.000		
		40						30.01.2016	3,020.000		
6	8000059838	50	HE9718583050	31750102322-03, HE51173-NA,10	SS SMLS U TUBES(OD15.875X8600LL)	EA	6,040.000	30.12.2015	3,020.000		
		60						30.01.2016	3,020.000		
Special Remarks											
CheckList of Quality Interventions: BHEL reserves the right to enforce any or all of the following checks during execution of the order. There is no additional cost to the vendor on account of these checks.											
						TEST CERTIFICATE REQD: Y GUARANTEE REQ : Y SAMPLE REQD : N BID TYPE : TWO PART		For and on-behalf of Bharat Heavy Electricals Limited.  SURENDER PURCHASE OFFICER /PUR (HE&F)			

PRE - QUALIFICATION CRITERIA

BHEL Enquiry No. D3A1Ø59396 Dated 31.03.2015 for SS Seamless U Tubes

S. No.	BHEL Requirement	Vendor's Confirmation	Deviations if Any
1	The vendors, who are not a BHEL approved vendors, need to furnish following documents along with offer.		
	<u>Documents to be submitted along with offer by non-BHEL approved Suppliers for Stainless Steel seamless U-Tubes for HP Heaters:</u>		
	(a) The supplier should have the proven experience in manufacturing and supply of Stainless Steel seamless U tubes for High Pressure Feed water heater in power plant application as mentioned below.		
	(i) Material SA 213 TP 304		
	(ii) Tube OD : 15.875 mm		
	(iii) Tube Thickness: 2.1 mm minimum or thicker.		
	(iv) Application: High Pressure Feed water heater (HP Heater).		
	(v) Service: Power plant.		
	(vi) Satisfactory Working of equipment: At least one year in a power plant.		
	(vii) The supplier shall be a original U-Tube manufacturer. All the facilities required for manufacturing U-tubes from mother hollows or round bars, shall be readily available with the vendor. Ex: Bright annealing facility, online or offline eddy current testing facility, hydrostatic testing facility (Hydrostatic test pressure: 545 kg/sq.cm (g) minimum), U-bend stress relieving facility etc.		
2	(viii) The tubes shall be manufactured by hot extrusion method, other methods are not acceptable.		
	All the above criteria 2(a) (i) to 2(a) (viii) must be combinedly met by the vendor against a single supply reference of U tubes.		
	Supplier's having experience in other applications other than High Pressure Feed Water Heaters in a Power plant will not be treated as a proven experience.		

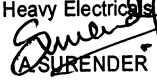
Vendor's Signature with Seal

PRE - QUALIFICATION CRITERIA

BHEL Enquiry No. D3A1Ø59396 Dated 31.03.2015 for SS Seamless U Tubes

S. No.	BHEL Requirement	Vendor's Confirmation	Deviations if Any
	(b) The supplier meeting all the above criteria as 2 (a) (i) to 2 (a) (viii) shall furnish details of such supplies only as indicated above sl no 2 (a) including equipment (HP Heater) Manufacturer's Name, power plant name, date of supply (in DDMMYY format), No of years the equipment (HP Heater) is in service, Size, Quantity and full contact details of equipment (HP Heater) Manufacturer & power plant. (OR) End user (power plant) certificate with supply details as above both 2 (a) & 2 (b) may be furnished.		
	(c) BHEL reserves the right to cross verify with the above such customers and satisfy itself with reference to the claims of the supplier. If the information furnished by the supplier is not found satisfactory, the offer will be technically rejected.		
3	The vendors shall download the vendor registration forms from BHEL website (www.bhel.com) and submit the duly filled in forms with supporting data along with the technical offers.		
4	Offers without the requirement as above 2(a) & 2(b) may not be technically evaluated by BHEL. Further, no correspondence in this matter will be entertained.		
5	BHEL approved vendors need not supply above information along with offer.		

Vendor's Signature with Seal

PRE - QUALIFICATION CRITERIA

BHEL Enquiry No. D3A1Ø59396 Dated 31.03.2015 for SS Seamless U Tubes

S. No.	BHEL Requirement	Vendor's Confirmation	Deviations if Any
6	<p>For making S.S. Seamless tubes the mother hollows are made from a round bar.</p> <p>(a) The round bars are to be sourced from the following vendors: (i) MUKAND, Mumbai (ii) BEW, Germany (iii) ITALFOND, Italy (iv) VIRAJ Profiles Ltd, Mumbai</p> <p>(b) In case, the vendors are sourcing the mother hollows directly for making S.S. Seamless tubes, the mother hollows are to be sourced from the following vendors: (i) SANYO, Japan (ii) POSCO, South Korea (iii) SANDVIK, Sweden (iv) SUMITOMO, Japan (v) KOBE STEEL, Japan (vi) Nippon Steel, Japan</p> <p>(c) The mother hollows shall be produced by hot extrusion method.</p> <p>If the tube manufacturer desires to source round bars or mother hollows from any other reputed source, they may give full details of the round bars or mother hollows manufacturer like manufacturing and testing facilities, size ranges and the customers to whom they are supplying. BHEL reviews the credentials of such supplier, and may accept the proposal if it is satisfied technically. The decision of BHEL is final in this regard.</p>		
7	<p>The vendors should furnish the detailed process of manufacturing and testing procedures along with the offer.</p>		
8	<p>The above requirements are in addition to the NIT conditions of the Purchase enquiry.</p>		

Vendor's Signature with Seal

**SPECIAL CONTRACT CONDITIONS (SCC)
FOR ENQUIRY NO. D3A1059396 Dated 31.03.2015**

S. NO.	TERMS & CONDITIONS	BHEL REQUIREMENT	VENDOR'S CONFIRMATION / REPLY
1	PRE-QUALIFICATION CRITERIA	-	
2	NAME & ADDRESS	Name, address, e-mail id, contact no.etc. of manufacturing mill for SS Seamless U Tubes.	
		Name, address, e-mail id, contact no.etc. of authorised agency / trading house quoting on behalf of manufacturing mill.	
		Valid letter of authorisation and copy of agreement to be enclosed with offer. The offer should be either from the authorised agency or from the manufacturer directly. In case of BHEL receiving offer from both, then offer from manufacturer will be considered. Offer from an unauthorised agency / entity on behalf of any vendor shall be summarily rejected.	
		Name, address, e-mail id, contact no.etc. of entity on whom order to be released in case of L1.	
3	TECHNICAL TERMS		
3A	DESCRIPTION & SIZE	As per Enquiry	
3B	QUANTITY	(i) Item No.1: Quantity of tubes - 4 x 1850 = 7400 Nos. (ii) Item No.2: Quantity of tubes - 4 x 1850 = 7400 Nos. (iii) Item No.3: Quantity of tubes - 4 x 1850 = 7400 Nos. (iv) Item No.4: Quantity of tubes - 2 x 3020 = 6040 Nos. (v) Item No.5: Quantity of tubes - 2 x 3020 = 6040 Nos. (vi) Item No.6: Quantity of tubes - 2 x 3020 = 6040 Nos.	
3C	SPECIFICATION	HE51173 Rev: 10	
3D	MATERIAL	SA213 TP304 with Carbon max 0.05% as per ASME Sec - II Part-'A' 2013 Edition and Addenda Nil shall be followed.	
3E	DRAWING	(i) For Item No. 1, 2 & 3: 3-175-01-02320 Rev: 00 (ii) For Item No. 4, 5 & 6: 3-175-01-02322 Rev: 00	
3F	QUALITY PLAN	HY/HE/010/SEMALESS U - TUBES Rev: 02	
4	PACKING & MARKING	As per BHEL Standard AA0490003 Rev:02. Foreign vendors shall provide sea-worthy packing.	
5	TERMS OF DELIVERY	FOR BHEL for Indian Vendors.	
		CIF Mumbai basis for Foreign Vendors.	
5A	FOR BHEL price / delivery implies (for Indian Suppliers)	a) Freight & Insurance are in vendor's scope and price quoted is inclusive of F & I.	
		b) Date of receipt of material at BHEL stores i.e. C - Note date is date of delivery for the purpose of penalty.	
5B	CIF Mumbai price / delivery implies (for Foreign Suppliers)	a) As per Incoterm.	
		b) IGM date in bill of entry issued by customs shall be delivery date for the purpose of penalty.	
		c) Exchange rate for Foreign Currency to INR shall be as per SBI Exchange rate (TT Seeling rate) as on Technical Bid Opening date. If the relevant day happens to be a bank holiday, then the forex rate as on the previous bank (SBI) working day shall be taken.	

**SPECIAL CONTRACT CONDITIONS (SCC)
FOR ENQUIRY NO. D3A1059396 Dated 31.03.2015**

S. NO.	TERMS & CONDITIONS	BHEL REQUIREMENT	VENDOR'S CONFIRMATION / REPLY
6	INSPECTION & CERTIFICATION	Indian Vendors: By BHEL TPIA as per Quality Plan and CIB in Form III B.	
		Foreign Vendors: By Lloyd's / TUV / BV / DNV (Overseas Inspection Agency) as per Quality Plan and in IBR Form III B. (Note: The above Inspection & Certification agencies shall be authorized / recognized / competent authority under Indian Boiler Regulations (IBR)1950 in the respective supplier's country).	
6A	Third Party Inspection Charges	Indian Vendors: By BHEL and vendor's offer will be loaded by appropriate percentage for evaluation of offers. Currently it is 0.165%.	
		Foreign Vendors: Shall be inclusive in quoted price.	
6B	CIB Charges / Certification in IBR Form - III B	Indian Vendors: Shall be inclusive in quoted price.	
		Foreign Vendors: Included in the scope of vendor for overseas inspection & certification agency in IBR Form-III B as indicated at S.No. 6.	
7	PACKING & FORWARDING	P & F charges shall be inclusive in price.	
8	FRIEGHT & INSURANCE	By supplier up to delivery point	
9	DELIVERY	(i) 3700 Nos. each of Item No.1, Item No.2 and Item No.3 :- 5 months from PO date.	(i) ___ Months
		(ii) 3700 Nos. each of Item No.1, Item No.2 and Item No.3 :- 8 months from PO date.	(ii) ___ Months
		(iii) 3020 Nos. each of Item No.4, Item No.5 and Item No.6 :- 6 months from PO date.	(iii) ___ Months
		(iv) 3020 Nos. each of Item No.4, Item No.5 and Item No.6 :- 7 months from PO date.	(iv) ___ Months
		Note: (a) For any deviation in delivery period as indicated above, quoted prices of Item No.1, 2, 3, 4, 5 & 6 of each schedule shall be loaded by 0.5% per week for evaluation of offer. (b) Delivery is critical to evaluation of offer. BHEL reserves the right to reject offer with delivery time not meeting project delivery schedule.	
10	MSME	“MSE suppliers can avail the intended benefits only if they submit along with the offer, attested copies of either EM II certificate having deemed validity (Five years from the date of issue of acknowledgement in EM-II) or valid NSIC certificate or EM II certificate along with attested copy of a CA certificate (Format enclosed as per Annexure – I where deemed validity of EM-II certificate of five years has expired) applicable for the relevant financial year (latest audited). Date to be reckoned for determining the deemed validity will be the date of bid opening (Part-I in case of two part bid). Non submission of such documents will lead to consideration of their bid at par with other bidders. No benefit shall be applicable for this enquiry if any deficiency in the above required documents are not submitted before price bid opening. If the tender is to be submitted through E-Procurement portal, then the above required documents are to be uploaded on the portal. Documents should be notarized or attested by a Gazetted Officer.”	

**SPECIAL CONTRACT CONDITIONS (SCC)
FOR ENQUIRY NO. D3A1Ø59396 Dated 31.03.2015**

S. NO.	TERMS & CONDITIONS	BHEL REQUIREMENT	VENDOR'S CONFIRMATION / REPLY
11	TWO-PART BID	Your offer shall be in two part bid system i.e, techno-commercial bid and price bid separately in two sealed covers indicating our enquiry No. D3A1Ø59396 date and tender due date clearly.	
11A	TECHNO-COMMERCIAL BID	<p>Techno-Commercial Bid shall essentially consist of:</p> <p>(i) Duly filled in signed copy of Special Contract Conditions (SCC). (ii) Duly filled in signed copy of Instructions to Bidder (ITB). (iii) Signed copy of General Conditions of Contract (GCC). (iv) Annexure - I if required. (v) Duly filled in Pre-Qualification Criteria (PQC) (vi) Signed copy of Technical Requirements and Un-Priced Bid format. (vii) Filled in and signed Integrity Pact.</p> <p>Note: Bid shall be complete in all respects including all the documents / information required for techno-commercial evaluation. Incomplete offers shall be liable to rejection.</p>	
11B	PRICE BID	Quoted price shall be on firm basis. Vendor shall quote prices strictly as per the pricing sheet enclosed.	
12	REVERSE AUCTION	<p>BHEL reserves the right to go for Reverse Auction (RA) instead of opening the sealed envelope price bid, submitted by the bidder. This will be decided after techno-commercial evaluation. All bidders to give their acceptance for participation in RA. Non-acceptance to participate in RA may result in non-consideration of their bids, in case BHEL decides to go for RA.</p> <p>In case BHEL decides to go for Reverse Auction, only those bidders who have given their acceptance to participate in RA will be allowed to participate in the Reverse Auction. Those bidders who have given their acceptance to participate in Reverse Auction will have to necessarily submit "online sealed bid" in the Reverse Auction. Nonsubmission of "online sealed bid" by the bidder will be considered as tampering of the tender process and will invite action by BHEL as per extant guidelines in vogue.</p> <p>In this context you may also refer to Clause No. 2D of ITB and confirm compliance.</p>	
		Details of vendor's Representative participating in RA like Name, E-mail, Phone and Fax No.	
13	EVALUATION OF OFFERS	The offers will be evaluated on individual item wise L ₁ basis. The vendor shall quote rate per tube for every item.	
14	INDIAN AGENT COMMISSION	Foreign vendors may specify Indian Agent Commission if any, in percentage of basic price and confirm that same is inclusive. IAC shall be paid in INR only.	

**SPECIAL CONTRACT CONDITIONS (SCC)
FOR ENQUIRY NO. D3A1059396 Dated 31.03.2015**

S. NO.	TERMS & CONDITIONS	BHEL REQUIREMENT	VENDOR'S CONFIRMATION / REPLY
15	INTEGRITY PACT	<p>The vendor has to sign integrity pact with BHEL for this tender. Vendor may fill in the enclosed document and endorse with signature. Vendor to comply fully with the terms and conditions of Integrity Pact and any deviation is not acceptable to BHEL. BHEL has appointed Independent External Monitor (IEM) to monitor the pact. The name and address of IEM is</p> <p>Mrs. Pravin Tripathi, IA & AS (Retd.), D-243, Anupam Gardens, Lane IB, Neb Sarai, Sainik Farms, New Delhi – 110 068.</p>	
16	GENERAL CONDITIONS OF CONTRACT	Vendor to comply with GCC vide Doc No. HY:MM:GCC Rev.00 by signing the document and submitting signed copy along with the offer.	
17	D & B REPORT	Foreign vendors to submit along with offer Dun & Bradstreet Comprehensive Report showing the Business Summary to enable BHEL to judge financial soundness of the organization.	
18	GUARANTEE	Guarantee on the supplier for a period of 18 months from the date of dispatch or 12 months from the date of commissioning which ever is earlier.	
19	TERMS & CONDITIONS	Vendor is requested to furnish all details of the offer in this format. In case of any discrepancy between information furnished here and those furnished elsewhere in the bid, the information furnished in this document only shall be considered, and those furnished elsewhere shall be ignored.	
20	EARNEST MONEY DEPOSIT (EMD)	EMD charges not applicable for quoting against this tender.	
21	SOURCING OF ROUND BARS / MOTHER HOLLOWES	As indicated in S.No. 6 of Pre-Qualification Criteria. Vendor may suggest sources of round bars / mother hollowes different from standard sources mentioned in the list. BHEL may or may not accept new sources suggested by vendor. However, there is no provision of revision of price for acceptance or non-acceptance of new sources after opening of technical bid.	

Enquiry No: D3A1Ø59396
Dated: 31.03.2015

TECHNICAL REQUIREMENTS

S. No.	Material Code	Description	Drawing No	OD (mm)	Leg Length (mm)	No. of Tubes per Set	Total No. of Tubes	Confirmation (Yes / No)
1	HE9718586857	SS Seamless U Tubes	3-175-01-02320 Rev: 00	15.875	8500	1850	7400	
2	HE9718586865	SS Seamless U Tubes	3-175-01-02320 Rev: 00	15.875	11200	1850	7400	
3	HE9718586873	SS Seamless U Tubes	3-175-01-02320 Rev: 00	15.875	8000	1850	7400	
4	HE9718583033	SS Seamless U Tubes	3-175-01-02322 Rev: 00	15.875	7800	3020	6040	
5	HE9718583041	SS Seamless U Tubes	3-175-01-02322 Rev: 00	15.875	11200	3020	6040	
6	HE9718583050	SS Seamless U Tubes	3-175-01-02322 Rev: 00	15.875	8600	3020	6040	
		NOTE: 1) This format without Price shall be sent along with Technical Bid.						
	Vendor Signature:							
	Date:							
	Seal:							

BHARAT HEAVY ELECTRICALS LTD. , RC.PURAM, HYDERABAD

INSTRUCTIONS TO BIDDER (ITB)			
(Attachment to Enquiry No. D3A1Ø59396 Due on Date 21.04.2015 for submission by 10.00 hrs to open from 14.00 hrs.)			
NOTE: Bidder to confirm in affirmative by typing "YES" or "Applicable Data" in the response column. Deviations , if any shall be recorded in deviations/comments column (Separate sheet can be attached if needed). Non deviatable clauses are indicated as "NON DEVIATABLE".			
Sl. No.	DETAILED TERMS & CONDITIONS	VENDOR RESPONSE (YES/NO)	DEVIATIONS / COMMENT
1	SCOPE OF SUPPLY:		
	Signed & Sealed offers are invited for Scope of Supply and Services as detailed in the enquiry. Relevant enclosures/ supporting documents / catalogue, if any shall be enclosed to the technical offer.		NON DEVIATABLE
2	GENERAL INSTRUCTIONS:		
A	The quotation should be neatly typed and free from over writing/ erasures. Any correction or addition must be authenticated. The offer including annexures and brochures should be submitted in English.		NON DEVIATABLE
B	In case of Single-Part bid Tender, the complete bid shall be submitted in a single sealed cover superscribing the Tender number and due date. Incomplete offers are liable for rejection.		NON DEVIATABLE
C	Bidders to please note that the Terms & conditions contained in this document and Special conditions, if any, are to be read along with the General Conditions of the Contract of BHEL.		NON DEVIATABLE
D	BHEL reserves the right to decide the tender through Reverse Auction (RA) route. Bidders are requested to go through RA guideines (which are attached) and confirm acceptance of the same. Otherwise the offer is liable for rejection. BHEL will decide (after technical bid opening), at its discretion, to process the tender through Reverse Auction or by opening price bids. Vendors are advised not to quote higher prices in price bid, presuming that there will be an opportunity to reduce the same during Reverse Auction. In case BHEL decides to process the tender by opening the price bids instead of Reverse Auction, there is no provision for revising the quoted prices and vendors may lose the opportunity in view of the higher prices, if any, quoted by them.		
E	Vendors, taking deviations from the specified conditions , may indicate the same clearly in deviation column with reasons for such deviation . However, in case of deviation, BHEL reserves the right to reject the offer or load the Bid suitably for evaluation.		NON DEVIATABLE
F	Offers shall be submitted directly by vendor or his authorized repressentative /agent only and the offer should be in line with regulatory guidelines (i.e Agency agreement between principal vendor and agent / representative shall be attached which shall be a valid one and cover the scope of services rendered by Agent, Agency Commission etc.). OEM / Mill details shall be provided if supplier is not a manufacturer. Bid envelops shall bear the name of Supplier. In case of submission through authorized representative/agent, the name of representative/agent should be mentioned additionally apart from supplier name.		NON DEVIATABLE

BHARAT HEAVY ELECTRICALS LTD. , RC.PURAM, HYDERABAD

INSTRUCTIONS TO BIDDER (ITB)			
Sl. No.	DETAILED TERMS & CONDITIONS	VENDOR RESPONSE (YES/NO)	DEVIATIONS / COMMENT
G	<p>Bidder can also submit offer through email at his own risk. The offer to be submitted in two parts . Technical offer to be submitted to technicalbid@bhelhyd.co.in , and price bid to be submitted to pricebid@bhelhyd.co.in . Interchanging the information in the mails may lead to rejection of the offer. Supplier shall have no claim on e-mail offers sent on any other e-mail ID. BHEL is no way responsible for non receipt of offers sent thru email due to server break down / Internet failure / transmission error etc.</p> <p>In case of e-mail offers, the mail subject should contain Enquiry No., Due Date and Supplier Name. Supplier address including contact details shall be mentioned in the content of the mail. Without these details offer may be liable for rejection.</p>		NON DEVIATABLE
H	Offer received after the specified time of submission will be rejected. No further correspondence shall be entertained.		NON DEVIATABLE
I	Unsolicited offers shall not be considered		NON DEVIATABLE
3	OTHER PARTICULARS (Please indicate applicable data)		
A	Name of the Bid currency (freely tradable foreign currency for imports and Indian Rupees for indogenous purchase).		
B	Name of the Port of loading (applicable to imports).		
4	BID SUBMISSION PROCEDURE:		
i.	For Single Part Bids: Offers addressed to DGM / CMM, Vendor Complex, BHEL, Hyderabad must be sent in a sealed cover on which tender enquiry number and the due date shall be superscribed and sent by appropriate mode to above address or dropped in tender box located at vendor complex on or before the specified time of submission of offers, preferably in the bidder's envelop.		NON DEVIATABLE
ii.	For two-Part Bids:		
A	<p>Two part bid consisting of</p> <p>i) Techno-commercial Bid - (Part-I), with all technical specification & scope including bill of material etc., EMD (where applicable) and unpriced bid with all applicable Commercial Terms and Conditions, agency commission, duties, taxes and other charges except the price, superscribing enquiry No. (Techno-Commercial Bid) and due date AND</p> <p>ii) Price Bid (Part-II), containing ONLY the price (including agency commission, if any) and the applicable duties/taxes/other charges shall be kept in a separate sealed cover supersubscribing Enquiry no. (Price bid) & due date. Both these covers shall be kept in a Third cover supersubscribing Enquiry no. & due date.</p> <p>All techno commercial terms & conditions mutually agreed prior to price bid opening shall prevail and supercede any terms and conditions specified otherwise in price bid.</p>		NON DEVIATABLE
B	Techno-commercial Bid will be opened on the assigned date and price bids of only techno commercially acceptable bidders shall be opened with advance intimation. In case BHEL opts for Reverse Auction, the date of conducting RA will be intimated separately to all the acceptable bidders.		NON DEVIATABLE
C	The bidders whose bids are techno commercially not accepted will be informed & EMD (Earnest Money Deposit) shall be returned wherever submitted.		NON DEVIATABLE

BHARAT HEAVY ELECTRICALS LTD. , RC.PURAM, HYDERABAD

INSTRUCTIONS TO BIDDER (ITB)			
Sl. No.	DETAILED TERMS & CONDITIONS	VENDOR RESPONSE (YES/NO)	DEVIATIONS / COMMENT
D	Bidders will be allowed to submit the impact on their quoted prices due to changes in technical scope, specifications, commercial terms/conditions as specified in NIT and in the opinion of BHEL such changes warrant changes in prices. BHEL at its sole discretion may also invite revised prices if there are major changes in scope. Revised price bids/impact price will not be accepted after opening of technical bids unless otherwise specifically asked by BHEL.		NON DEVIATABLE
E	Bids shall be opened on due time and date in the presence of bidders who may like to be present. Only one representative of each bidder shall be permitted to attend the bid opening.		NON DEVIATABLE
5	Delivery Instructions		
A	Indigenous Purchase		
	Goods shall be delivered on FOR Destination basis to the named destination(s) or as specified in the enquiry.		
B.	Imports		
	The goods shall be delivered on FOB-port of export/FCA or as specified in enquiry. Name of port of export for FOB / FCA delivery shall be indicated against this column.		
6	Documentation:		
A	Indigenous Purchase		
	Seller shall arrange to send to the Purchaser, Excise paid invoice (Original for Buyer and duplicate for Transporter), Commercial invoice, consignee copy of LR, Packing list , Pre-Despatch Inspection report, Test/ Guaranty/ Warranty certificate/ O&M manuals (as applicable) etc. immediately on despatch of the goods. Any addition/ exclusion to such documents shall be as specified in the Purchase Order. The distribution of such documents will be further elaborated in the Purchase order. In case of despatches from vendor works to site, material receipt certified by site office shall be provided.		NON DEVIATABLE
B	Imports		
	Seller shall arrange to send to the Purchaser one set of negotiable and one set of non-negotiable documents consisting of clean on-board Bill of Lading/ Air Way Bill, Original invoice, Packing list, Pre-Despatch Inspection report , Test/ Guaranty/ Warranty certificate/ O&M manuals (as applicable) and other documents as indicated in the Purchase Order etc. In addition, Seller shall also send soft copy of the despatch documents consisting of BL / AWB, Invoice, Shipping list & Test certificates and other documents as indicated in the Purchase Order through e-mail addressed to the concerned Purchase Officer/ Manager.		NON DEVIATABLE

BHARAT HEAVY ELECTRICALS LTD. , RC.PURAM, HYDERABAD

INSTRUCTIONS TO BIDDER (ITB)			
Sl. No.	DETAILED TERMS & CONDITIONS	VENDOR RESPONSE (YES/NO)	DEVIATIONS / COMMENT
7	Delivery Schedule		
	The tendered goods shall be delivered within the period stipulated in PO. (In case of Imports, the date of BL / AWB will be reckoned as delivery completion date).		NON DEVIATABLE
8	Pricing Terms		
	Prices once quoted shall remain firm and valid during execution of PO. Offers with PVC will be outrightly rejected except in cases where specifically called for in the NIT.		NON DEVIATABLE
9	PRICE VALIDITY :		
	Unless other wise specified, offer shall be valid for a period of 90 days from the date of bid opening (Technical bid /part-I in case of two part bid). However the prices quoted for spare parts of the Main equipment shall be kept valid for a period of 180 days from the date of Placement of PO for the main equipment.		
10	Taxes & Duties. (DATA TO BE INDICATED by the bidder against the space provided)		
A	Indigenous Purchase		
	The Taxes and duties e.g. Excise duty, Service Tax, Sales Tax, VAT etc. as applicable shall be quoted in the following manner.		
i	Excise Duty : To be quoted as extra in % or lumpsum as quoted in the price bid.		
ii	CST against form C in %. Bidder shall also indicate full rate of sales Tax where Concesional form can not be issued by BHEL.		
iii	VAT : To be quoted in %.		
NOTE: Bidders to ensure correct applicability of CST / VAT based on the Inter / Intra state movement of goods.			
iv	In case the vendor imports the equipment/items and dispatches directly to BHEL/Destination, the vendor may please indicate whether they can pass on CVD benefit and if so, the quantum of CVD to be indicated here.		
v	Other taxes & duties, if any to be indicated here .		
vi	Taxes deducted at source: Statutory deductions, if any, will be made and the deduction certificate shall be issued. In case vendor does not provide PAN details, the TDS deduction shall be at the maximum percentage stipulated as per the provisions of Income Tax Act.		NON DEVIATABLE
B.	Foreign Purchase (Imports)		
i	The offered price shall be inclusive of all the Taxes and duties as applicable in country of bidder / country of despatch for his quoted FOB / FCA price.		NON DEVIATABLE
ii	Taxes deducted at source: Statutory deductions, if any, will be made and the deduction certificate shall be issued. In case vendor does not provide PAN details, the TDS deduction shall be at the maximum percentage stipulated as per the provisions of Income Tax Act.		NON DEVIATABLE

BHARAT HEAVY ELECTRICALS LTD. , RC.PURAM, HYDERABAD

INSTRUCTIONS TO BIDDER (ITB)			
Sl. No.	DETAILED TERMS & CONDITIONS	VENDOR RESPONSE (YES/NO)	DEVIATIONS / COMMENT
11	Payment Terms: Unless otherwise specified in Special Conditions, following shall be terms of Payment.		
A	<p><u>Indigenous:</u> 100% payment along with taxes, duties, freight & insurance will be made with in 90 days from the date of LR/invoice. However payment would be done only after receipt of original documents, including site acknowledgement on LR (MRC - Material Receipt Certificate at site) / GR clearance at BHEL Stores. For MSEs (covered under MSME Act) which are registered and periodically renewed with BHEL, this period will be 45 days. The taxes and duties that are reimbursed would be the one applicable as on the scheduled Purchase Order delivery date or the amount actually paid whichever is less.</p>		
B	<p><u>Imports:-</u> 1. Cash against documents / Sight draft Purchaser can also accept payment terms against presentation of documents to the Purchaser's Bank / sight draft. All banking charges outside India will have to be borne by the supplier. OR 2) Against LC: i) 100% payment (less Indian Agency Commission, if any) shall be paid against irrevocable Letter of Credit . ii) LC shall be opened only in the name of vendor on whom purchase order is placed. iii) LC will be opened 1 month prior to the scheduled delivery of PO. LC shall be valid for a period of 3 months including the bank negotiation period of 21 days from the date of opening.</p>		
	<p><u>Note:</u> 1) No advance payment is acceptable . The offer is liable to be rejected in case advance payment is insisted. However, in exceptional/rare cases, BHEL at its descretion, may consider advance payment against Bank Guarantee for 110% of advance amount issued / confirmed by any of the BHEL consortium banks. 2) Wherever EMD (Earnest Money Deposit) is applicable, it may be noted that no interest will be paid on EMD and the EMD will be paid back to participating bidders only after awardal and acceptance of contract by successful bidder. Successful bidder's EMD will be converted to SD (Security Deposit).</p>		NON DEVIATABLE
12	<p><u>Penalty clause:</u> In the event of delay in supply of goods, penalty of 0.5% per week or part there of shall be levied on the undelivered portion subject to a maximum of 10% of the order value.</p>		
13	<p><u>Guarantee / Warranty Period deviations :</u> (Deviation to this clause is not acceptable.)</p>		NON DEVIATABLE

BHARAT HEAVY ELECTRICALS LTD. , RC.PURAM, HYDERABAD

INSTRUCTIONS TO BIDDER (ITB)	
<p>NOTE: Deviations (Commercial as well as Technical) from the tender specifications and conditions are generally not acceptable. However, deviation if any, shall be brought out clearly with proper justification in the offer. The deviation, if considered by BHEL, shall be loaded for comparison, while evaluating the offer. If a bidder unconditionally withdraws any deviation before price bid opening, the same shall not be loaded. Loading criteria in respect of major commercial conditions where deviations if any are accepted shall be as per clause No.14. The Vendors may specifically note the following.</p>	
14	Evaluation and Loading Criteria:
A	Evaluation of prices shall be done item-wise unless otherwise specified in the enquiry. Evaluation shall be on the basis of delivered cost, i.e. “total cost to BHEL” w.r.t the finalized technical scope and commercial conditions (after considering incidence of applicable taxes and duties and loading). For evaluation, exchange rate (TT selling rate of State Bank of India) as on the date of bid opening (Part-I, in case of two-part bids) shall be considered. If the relevant day happens to be a bank holiday, then the forex rate as on the previous bank (SBI) working day shall be taken.
B (a)	In case of foreign bidders , the quoted FOB price shall be loaded by the following factors to arrive at the Delivered Cost:
i	- Marine freight and insurance: @ 3% (10% for plates, pipes, rounds & structurals) . In case of CFR offers, Insurance @ 0.1% will be loaded.
ii	- Import duty as applicable at the time of Price/ Part-II bid opening.
iii	- Port handling/ clearing charges & inland freight : @ 3.0% of FOB value (5% for plates, pipes & structurals).
B (b)	Incase of Indigenous Bidders , Ex-works offers received (as against FOR Destination mentioned in enquiry) shall be loaded by 3% of Ex-works value (5% for plates, pipes, rounds & structurals) unless otherwise mentioned in enquiry.
C	Deviated Penalty : Any loading on penalty clause shall be 10% or to the extent to which it is not agreed to by the vendor.
D	Deviated Payment Terms: In case BHEL considers any deviation in payment terms, the bids shall be loaded with 18% interest per annum.
15	Procurement directly from the manufacturers/ suppliers shall be preferred. However, no agent shall be allowed to represent more than one manufacturer/ supplier in the same tender. Moreover, either the agent could bid on behalf of the manufacturer/ supplier or the manufacturer / supplier could bid directly but not both. In case bids are received from both from the manufacturer/ supplier and the agent, bid received from the agent shall be ignored.
16	RIGHT OF REJECTION /NON- PLACEMENT OF PO: BHEL reserves the right to accept or reject any or all bid/s in full or part without assigning any reason whatsoever.

DRG. NO. 3-175-01-02320

SL.NO.	RADIUS "R"	LEG LENGTH	H.P.HEATER NO. 6A/6B			H.P.HEATER NO. 7A/7B			H.P.HEATER NO. 8A/8B			
			QTY.	THK	DEV. LENGTH	QTY.	THK	DEV. LENGTH	QTY.	THK	DEV. LENGTH	
1	31.7	L	2.35	MIN	62	2.40	MIN	62	2.45	MIN	62	16100
2	49.6	L	2.35	MIN	64	2.40	MIN	64	2.45	MIN	64	16156
3	67.5	L	2.35	MIN	65	2.40	MIN	65	2.45	MIN	65	16212
4	85.4	L	2.20	MIN	64	2.30	MIN	64	2.35	MIN	64	16268
5	103.2	L	2.20	MIN	65	2.30	MIN	65	2.35	MIN	65	16324
6	121.1	L	2.20	MIN	66	2.30	MIN	66	2.35	MIN	66	16380
7	139.0	L	2.20	MIN	63	2.30	MIN	63	2.35	MIN	63	16437
8	156.9	L	2.20	MIN	62	2.20	MIN	62	2.25	MIN	62	16493
9	174.7	L	2.20	MIN	63	2.30	MIN	63	2.35	MIN	63	16549
10	192.6	L	2.10	MIN	64	2.30	MIN	64	2.35	MIN	64	16605
11	210.5	L	2.10	MIN	63	2.30	MIN	63	2.35	MIN	63	16661
12	228.4	L	2.10	MIN	62	2.20	MIN	62	2.31	MIN	62	16718
13	246.2	L	2.10	MIN	61	2.20	MIN	61	2.31	MIN	61	16773
14	264.1	L	2.10	MIN	62	2.20	MIN	62	2.32	MIN	62	16830
15	282.0	L	2.10	MIN	61	2.20	MIN	61	2.32	MIN	61	16886
16	299.9	L	2.10	MIN	60	2.20	MIN	60	2.34	MIN	60	16942
17	317.7	L	2.10	MIN	59	2.20	MIN	59	2.35	MIN	59	16998
18	335.6	L	2.10	MIN	58	2.20	MIN	58	2.35	MIN	58	17054
19	353.5	L	2.10	MIN	53	2.20	MIN	53	2.35	MIN	53	17111
20	371.4	L	2.10	MIN	54	2.20	MIN	54	2.35	MIN	54	17167
21	389.2	L	2.10	MIN	55	2.20	MIN	55	2.36	MIN	55	17223
22	407.1	L	2.10	MIN	54	2.20	MIN	54	2.36	MIN	54	17279
23	425.0	L	2.10	MIN	51	2.20	MIN	51	2.37	MIN	51	17335
24	443.0	L	2.10	MIN	50	2.20	MIN	50	2.37	MIN	50	17391
25	460.7	L	2.10	MIN	49	2.20	MIN	49	2.38	MIN	49	17447
26	478.6	L	2.10	MIN	48	2.20	MIN	48	2.39	MIN	48	17504
27	496.5	L	2.10	MIN	45	2.20	MIN	45	2.39	MIN	45	17560
28	514.4	L+6	2.10	MIN	44	2.20	MIN	44	2.40	MIN	44	17628
29	532.2	L+12	2.10	MIN	41	2.20	MIN	41	2.40	MIN	41	17696
30	550.1	L+18	2.10	MIN	36	2.20	MIN	36	2.41	MIN	36	17764
31	568.0	L+24	2.10	MIN	35	2.20	MIN	35	2.42	MIN	35	17832
32	585.9	L+30	2.10	MIN	34	2.20	MIN	34	2.43	MIN	34	17901
33	603.8	L+36	2.10	MIN	31	2.20	MIN	31	2.43	MIN	31	17969
34	621.7	L+42	2.10	MIN	26	2.20	MIN	26	2.44	MIN	26	18037
35	639.6	L+48	2.10	MIN	20	2.20	MIN	20	2.45	MIN	20	18105
TOTAL / HEATER			1850	U		1850	U		1850	U		
TOTAL DEVELOPED LENGTH IN METER			2.35	MIN	3276.964	2.40	MIN	4308.364	2.45	MIN	3085.964	
FOR TUBE BUNDLE / HEATER			2.20	MIN	6666.976	2.30	MIN	10207.496	2.30	MIN	9432.855	
ESTIMATED WEIGHT OF TOTAL NUMBER OF TUBES PER HEATER IN KGS./HEATER			2.10	MIN	23244.761	2.20	MIN	28662.841	2.20	MIN	18819.882	~25567

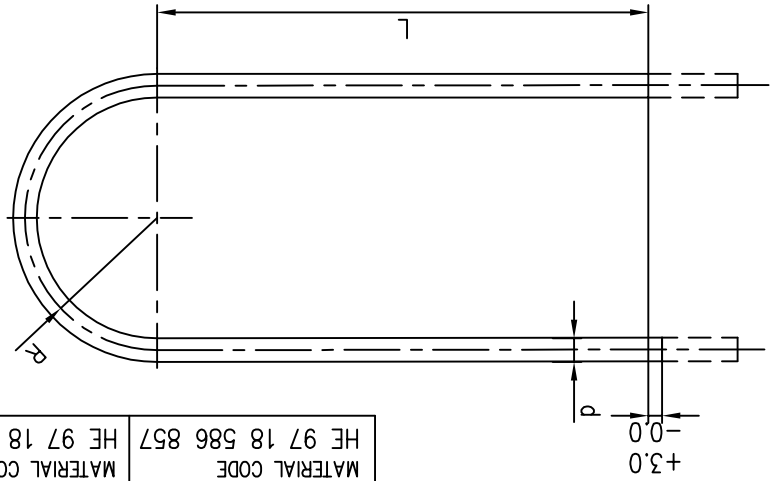

NOTES:-

- MATERIAL SA 213 TP 304 WITH CARBON MAX. 0.05% AS PER ASME SEC - II PART - A, YEAR OF EDITION AND ADDENDA AS PER P.O/ INDENT.
- TECHNICAL REQUIREMENTS AS PER PRODUCT STANDARD
- HE 5 1173 REVISION LATEST AS PER P.O/INDENT AND AS PER MATL. SPECIFICATION.
- QUALITY PLAN :- HY/ HE/ O10/SEAMLESS U-TUBES REVISION LATEST AS PER P.O/INDENT.
- INSPECTION :- AS PER P.O/INDENT
- HYDRO TEST PRESSURE ON EACH TUBE = 545 kg/sq.cm (g)
- MINIMUM WALL THICKNESS = +20% -0%
- MAXIMUM WORKING PRESSURE (DESIGN PRESSURE) : 350 kg/sq.cm (g)
 - MAXIMUM WORKING TEMP. (DESIGN TEMP.) : 330 C
 - OPERATING MEDIUM : SHELL SIDE - STEAM & DRAIN. TUBE SIDE - FEED WATER.

REV. DATE		ALTERED	CHECKED	APPD	REV. DATE	ALTERED	CHECKED	APPD	REV. DATE	ALTERED	CHECKED	APPD
DEPT. HEE		GRADE OF	TOL. DIM.	C/M/F	SCALE	NTS	WEIGHT (KG)	NA	REF. TO ASSY DRG.	NO. OF ITEMS	NA	NA
CODE 405		TITLE U - TUBE FOR H.P HEATER - 6A/6B,7A/7B&8A/8B		CARD	DRAWING NO. 3-175-01-02320		REV. 00	SHEET NO. 1		NO OF SHEETS 1		

TYPE OF PRODUCT OR NAME OF CUSTOMER/PROJECT		BHARAT HEAVY ELECTRICALS LTD. HYDERABAD	
NO. OF VAR.	DATE	NAME	SIGN.
NA	24.01.15	A K SAHOO	AKS
NO. OF CHD.	DATE	NAME	SIGN.
NA	24.01.15	K.KIRAN KUMAR	KK
NO. OF APPD.	DATE	NAME	SIGN.
NA	24.01.15	B.SRINIVAS	BS

(ALL DIMENSIONS ARE IN mm)

FIRST ANGLE PROJECTION

DRG. NO. 3-175-01-02320

SL. NO.	RADIUS "R"	LEG LENGTH	H.P. HEATER NO. 6			H.P. HEATER NO. 7			H.P. HEATER NO. 8			
			THK	QTY.	DEV. LENGTH	THK	QTY.	DEV. LENGTH	THK	QTY.	DEV. LENGTH	
1	31.7	L	2.35	MIN	72	22500	78	22556	78	17356	72	17300
2	49.6	L	2.35	MIN	78	15756	78	22556	78	17356	78	17356
3	67.5	L	2.35	MIN	79	15812	79	22612	79	17412	79	17412
4	85.4	L	2.20	MIN	80	15868	80	22668	80	17468	80	17468
5	103.2	L	2.20	MIN	79	15924	79	22724	79	17524	79	17524
6	121.1	L	2.20	MIN	80	15980	80	22780	80	17580	80	17580
7	139.0	L	2.20	MIN	83	16037	83	22837	83	17637	83	17637
8	156.9	L	2.20	MIN	84	16093	84	22893	84	17693	84	17693
9	174.7	L	2.20	MIN	83	16149	83	22949	83	17749	83	17749
10	192.6	L	2.20	MIN	82	16205	82	23005	82	17805	82	17805
11	210.5	L	2.20	MIN	81	16261	81	23061	81	17861	81	17861
12	228.4	L	2.10	MIN	78	16318	78	23118	78	17918	78	17918
13	246.2	L	2.10	MIN	79	16373	79	23173	79	17973	79	17973
14	264.1	L	2.10	MIN	80	16430	80	23230	80	18030	80	18030
15	282.0	L	2.10	MIN	79	16486	79	23286	79	18086	79	18086
16	299.9	L	2.10	MIN	80	16542	80	23342	80	18142	80	18142
17	317.7	L	2.10	MIN	79	16598	79	23398	79	18198	79	18198
18	335.6	L	2.10	MIN	78	16654	78	23454	78	18254	78	18254
19	353.5	L	2.10	MIN	77	16711	77	23511	77	18311	77	18311
20	371.4	L	2.10	MIN	76	16767	76	23567	76	18367	76	18367
21	389.2	L	2.10	MIN	75	16823	75	23623	75	18423	75	18423
22	407.1	L	2.10	MIN	74	16879	74	23679	74	18479	74	18479
23	425.0	L	2.10	MIN	73	16935	73	23735	73	18535	73	18535
24	443.0	L	2.10	MIN	72	16992	72	23792	72	18592	72	18592
25	460.7	L	2.10	MIN	71	17047	71	23847	71	18647	71	18647
26	478.6	L	2.10	MIN	70	17104	70	23904	70	18704	70	18704
27	496.5	L	2.10	MIN	67	17160	67	23960	67	18760	67	18760
28	514.4	L+6	2.10	MIN	66	17228	66	24028	66	18828	66	18828
29	532.2	L+12	2.10	MIN	67	17296	67	24096	67	18896	67	18896
30	550.1	L+18	2.10	MIN	66	17365	66	24165	66	18965	66	18965
31	568.0	L+24	2.10	MIN	63	17433	63	24233	63	19033	63	19033
32	585.9	L+30	2.10	MIN	62	17501	62	24301	62	19101	62	19101
33	603.8	L+36	2.10	MIN	61	17569	61	24369	61	19169	61	19169
34	621.7	L+42	2.10	MIN	60	17637	60	24437	60	19237	60	19237
35	639.6	L+48	2.10	MIN	57	17706	57	24506	57	19306	57	19306
36	657.5	L+54	2.10	MIN	56	17774	56	24574	56	19374	56	19374
37	675.4	L+60	2.10	MIN	53	17842	53	24642	53	19442	53	19442
38	693.3	L+66	2.10	MIN	50	17910	50	24710	50	19510	50	19510
39	711.2	L+72	2.10	MIN	49	17979	49	24779	49	19579	49	19579
40	729.1	L+78	2.10	MIN	46	18047	46	24847	46	19647	46	19647
41	747.0	L+84	2.10	MIN	43	18115	43	24915	43	19715	43	19715
42	764.9	L+90	2.10	MIN	40	18183	40	24983	40	19783	40	19783
43	782.8	L+96	2.10	MIN	37	18252	37	25052	37	19852	37	19852
44	800.7	L+102	2.10	MIN	30	18320	30	25120	30	19920	30	19920
45	818.6	L+108	2.10	MIN	25	18388	25	25188	25	19988	25	19988
TOTAL / HEATER			3020 U			3020 U			3020 U			
2.35 MIN			3608.52			5165.72			3974.92			
2.20 MIN			10475.04			16711.84			11518.24			
2.10 MIN			36708.48			49450.47			40130.88			
ESTIMATED WEIGHT OF TOTAL NUMBER OF TUBES PER HEATER IN KGS./HEATER			~39683			~58014			~45904			

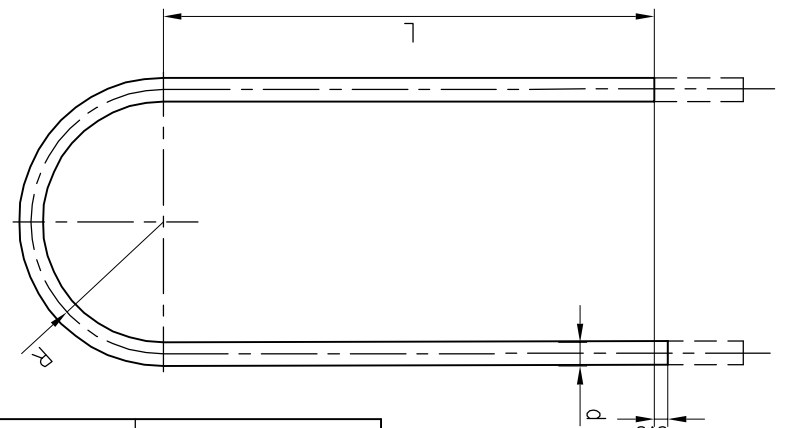

NOTES:-

- MATERIAL SA 213 TP 304 WITH CARBON MAX. 0.05% AS PER ASME SEC - II PART - A, YEAR OF EDITION AND ADDENDA AS PER P.O/ INDENT.
- TECHNICAL REQUIREMENTS AS PER PRODUCT STANDARD
- HE 5 1173 REVISION LATEST AS PER P.O/INDENT AND AS PER MATL. SPECIFICATION.
- QUALITY PLAN :- HY/ HE/ O10/SEAMLESS U-TUBES REVISION LATEST AS PER P.O/INDENT.
- INSPECTION :- AS PER P.O/INDENT
- HYDRO TEST PRESSURE ON EACH TUBE = 545 kg/sq.cm (g)
- MINIMUM WALL THICKNESS = +20% -0%
- MAXIMUM WORKING PRESSURE (DESIGN PRESSURE) : 350 kg/sq.cm (g)
 - MAXIMUM WORKING TEMP. (DESIGN TEMP.) : 326 °C
 - OPERATING MEDIUM : SHELL SIDE - STEAM & DRAIN. TUBE SIDE - FEED WATER.

TYPE OF PRODUCT OR NAME OF CUSTOMER/PROJECT		BHARAT HEAVY ELECTRICALS LTD. HYDERABAD	
DRN.	RAJESH M	APPD.	B.SRINIVAS
NAME	M RAJESH	CHD.	K KIRAN KUMAR
SIGN.			
DATE	06.02.15	DATE	06.02.15
VAR.	NA	VAR.	NA
NO.OF	NA	NO.OF	NA
ITEM	NA	ITEM	NA
NO.	NA	NO.	NA
NO.OF	NA	NO.OF	NA
REF. TO ASSY DRG.	NA	REF. TO ASSY DRG.	NA
CARD CODE	NA	CARD CODE	NA
TITLE U - TUBE FOR H.P. HEATERS		DRAWING NO. 3-175-01-02322	
SHEET No. 1		NO OF SHEETS 1	

(ALL DIMENSIONS ARE IN mm)

FIRST ANGLE PROJECTION



CORPORATE STANDARD

AA 049 00 03

Rev. No. 02

PAGE 1 OF 4

PRESERVATION, PACKING AND MARKING OF U-BENT HEAT EXCHANGER TUBES

1.0 SCOPE:

This standard stipulates the requirements preservation, packing and marking of ferrous and non ferrous U-Bent heat exchanger tubes.

2.0 PRESERVATION:

2.1 End Caps/Guides:

All the tubes shall be provided with plastic end caps of conical shape on both ends, in order to avoid ingress of water and other foreign matter.

A typical figure of the plastic cap is shown in the fig 3 for guidance.

2.2 Rust prevention:

All carbon steel tubes shall be applied with suitable temporary rust preventive on the outer surface of the tubes, and required quantity of rust inhibitive powder shall be inserted inside the tubes before end capping.

3.0 PACKING:

3.1 All tubes shall be packed and blocked in such a manner as to prevent damage in ordinary handling and transportation.

The boxes shall be constructed in such a manner that no nails, staples, screws or similar fasteners are required to close and secure the box after the tubes have been placed in the box. The box shall be lined with plastic sheet or vapour barrier materials so as to prevent chloride contamination of the tubes during handling, transportation and storage. The bottom of the case shall be rigid to enable the tubes to maintain straightness. Special lifting tackles, including beams, wherever necessary shall be provided with each case to avoid damage during transit. The U- bent tubes shall be arranged in boxes so that the smaller radius bends may be removed without disturbing larger radius bends. Tubes for each heat exchanger shall be boxed together.

A suitable amount of desiccant such as silica gel shall be placed in each packing box.

3.2 Each package shall be of convenient weight for ease in handling. The weights shall not exceed 2000 Kg (Gross).

3.3 Plastic/ nylon support guides as shown in fig.2 shall be placed in between the tubes in order to prevent rubbing of tube to tube and internal movement.

Revisions :

Cl. 18.11.01 of MRC – NFCW+HE

APPROVED :

INTERPLANT MATERIAL RATIONALIZATION
COMMITTEE-MRC (NFCW+HE)

Rev. No. 02

Amd.No.

Reaffirmed

Prepared

Issued

Dt. of 1st Issue

Dt: 15.02.2004

Dt :

Year :

HYDERABAD

Corp. R&D

DECEMBER, 1986



3.4 The U-bent tubes of different radii shall be inserted into the slots of the wooden supports which are firmly fixed in the box as shown in Fig.1

3.5 The recommended packing case design and the method of packing is illustrated in fig 1. Any alternate method of packing shall be submitted to BHEL with full particulars and drawings along with the offer for approval.

4.0 MARKING:

4.1 Each tube shall be stenciled with the following information:

- a) BHEL order number:
- b) BHEL Specification No.
- c) Melt/Heat No:
- d) Size of tube:
- e) Supplier 's mark

4.2 A metal label shall be securely attached to each packing case, punched with the following details :

- a) BHEL order number:
- b) BHEL Specification No.
- c) Consignment or Identification No.
- d) Size of the tubes & Total weight
- e) Supplier's Name

4.3 The packing case shall be marked with the following symbols in order to avoid damage during transit:

- a) A mark indicating UP-DOWN position of the case.
- b) A mark indicating that the case shall not be given any impact.
- c) A mark indicating that the case shall be kept free from contact with moisture.
- d) A mark showing the slinging position.

5.0 HANDLING AT PORT, SITE, SHOP, ETC., 9INCLUDING TRANSPORTATION):

5.1 Procedure:

If the tube length is more than 7000 mm invariably beams are ordered by BHEL, two in numbers which are supplied with first consignment by the vendor.

On receipt of consignment at port, boxes and lifting beams shall be inspected. If boxes are found broken, inspection of tubes shall be carried out. Broken box shall be suitably repaired before sending to site. Boxes shall be inspected before loading on the truck/trailer at supplier's works. Repair shall be carried out if required.

Invariably lifting beam shall be used for handling of boxes.

Boxes shall be placed on the floor on supports (at least 300 mm above the floor). Distance between supports shall not be more than 500 mm. While handling /stacking, vertical direction as marked on the box shall be followed.

Boxes shall be stacked on each other in such a way that are upright, straight and not projecting outside the lower box. Normally not more than 3 boxes shall be kept on each other.



CORPORATE STANDARD

AA 049 00 03

Rev. No. 02

PAGE 3 OF 4

5.2 Loading of boxes on trailers/trucks:

Preferably trailer shall be of flat floor and its length shall not less than the box. However, in case it is not feasible, following is recommended:

<u>Box length max. in metres</u>	<u>Floor length not less than in metres</u>
20	18.5
15	14
10	9.5
8	7.6

In case, the floor of trailer/truck is not flat, following procedure shall be adopted:

- Packers of suitable strength shall be placed on the floor such that when boxes are placed, the packer's bottom of the boxes is horizontal.
- Packers shall be placed such that at the driver end, the box projects maximum 300 mm from the support and on the opposite end, it is 300 mm less than end of the floor such that total projection from last support shall not be more than as specified above.
- Boxes shall be placed on each other as specified in clause 5.1. The each vertical row shall be secured tight using ropes /wires and tightened with each other and secured with the trailer floor suitably. The gap between the tightening rope/wire shall not be more than 2 metres.
- Out of two lifting beams, one number shall be sent with first consignment and the second lifting beam with the last consignment.
- Boxes shall be covered with tarpaulin and tightened suitably so as to prevent seepage of water.

5.3 Receipt at site:

The boxes shall be again inspected at the site for any breakage, if found shall be reported back to concerned unit.

The boxes from trailer/truck shall be lifted using lifting beam only supplied with the first and last consignment and stacked in the store in line with clause 5.1.

The boxes shall be covered with tarpaulin to prevent water seeping in the boxes.

6.0 REFERRED STANDARDS (LATEST PUBLICATIONS INCLUDING AMENDMENTS):

NIL

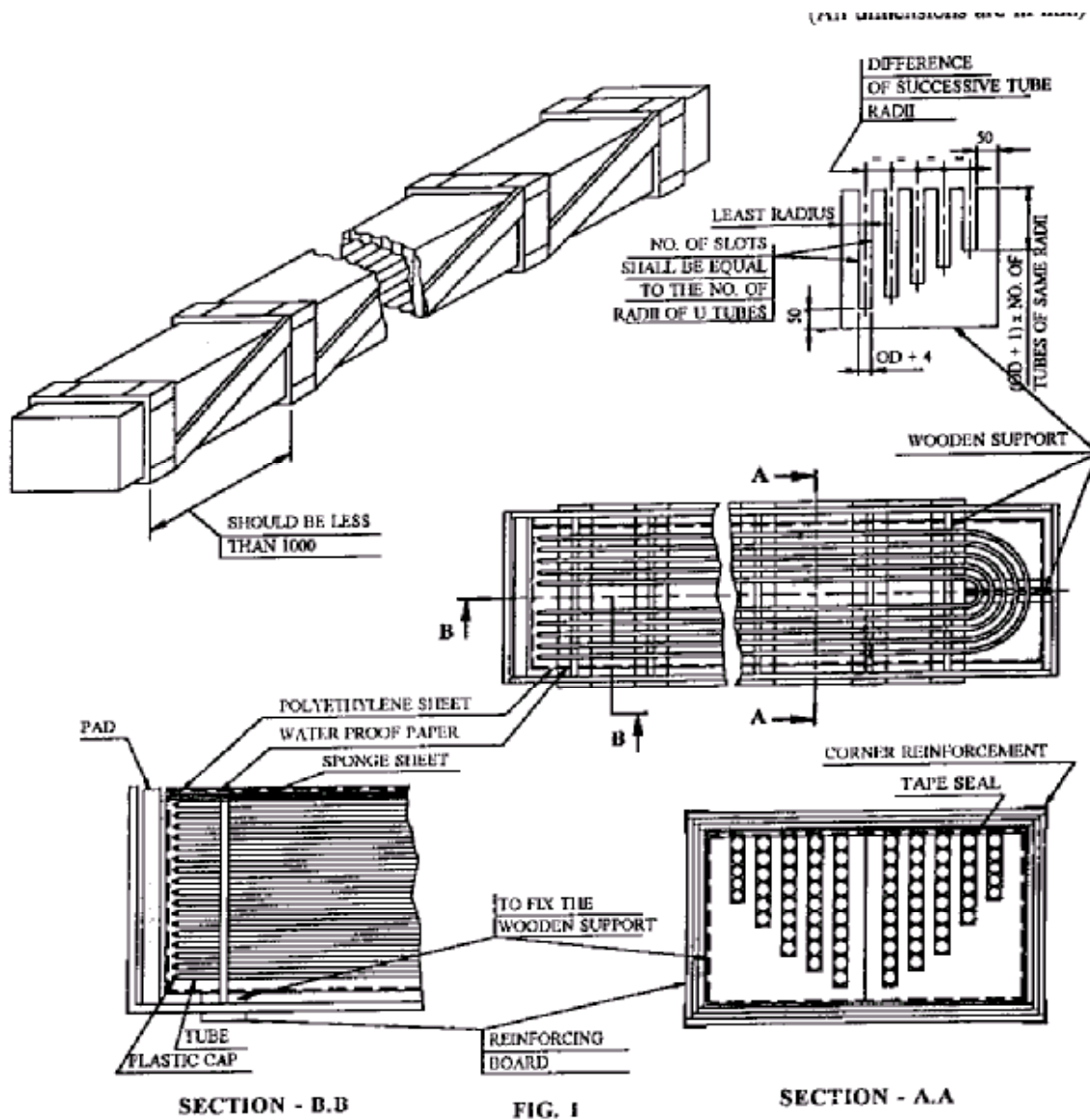
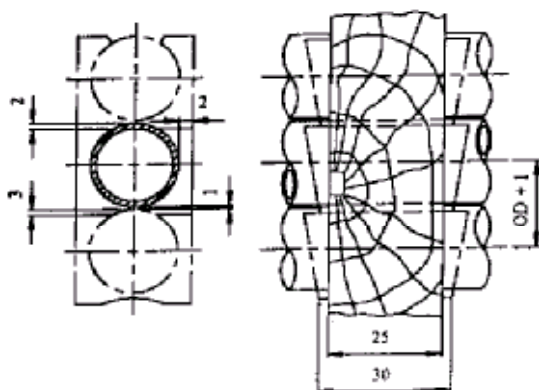
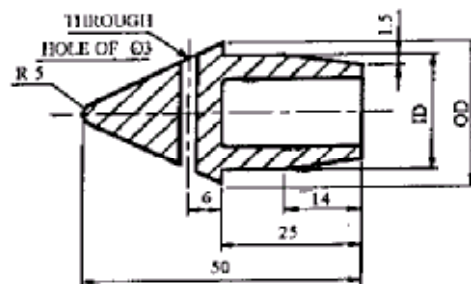



FIG. 1





SUPPORT GUIDE DETAIL
FIG. 2



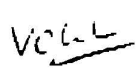



CAP FOR TUBE END
FIG. 3

TD-106-2 Rev-5	Form No.		PRODUCT STANDARD HEAT EXCHANGERS HYDERABAD		No: HE 5 1173
					REV. NO. 10
					Page 1 of 4
<p><u>SPECIFICATION FOR SEAMLESS TUBES FOR H.P. HEATERS L.P. HEATERS & DRAIN COOLERS (STAINLESS STEEL TUBES)</u></p> <p>1. Bend/straight tubes shall conform to SA 213 TP 304 / TP 304L/ TP 304N/ TP 316 as per drawing/enquiry/P.O with Carbon limited to 0.05 % max. in case of TP 304/ TP 304N/TP 316 and 0.035% in case of TP 304L. Carbon content Specified in the drawing/P.O shall be governing. Tubes shall be seamless cold drawn.</p> <p>2.1 Straight tubes or tubes ready for 'U' bending shall be furnished in the bright annealed condition (both inside and outside surfaces) with a minimum temperature of 1040°C followed by rapid cooling to below 370°C. The cooling rate shall be sufficiently rapid to prevent harmful carbide precipitation.</p> <p>2.2 After U bending U bent portion plus not less than 150 mm (6") of each straight leg of the tube beyond the tangent point of U bend shall be solution annealed to a minimum temp of 1040 °C followed by rapid cooling to below 370°C. U-bent tubes inside shall be purged with inert gas during heat treatment of U-bent portion.</p> <p>2.3 If the heat treatment of the U-bends as specified above is done by resistance heating methods, wherein electrodes are clamped to the tubes, the clamped areas shall be visually examined for arc burns. Burn indications shall be cause for rejection unless they can be removed by local polishing without encroaching upon, minimum wall thickness.</p> <p>Temperature control shall be accomplished through the use of optical or omission pyrometers or both. No temperature indicating crayons, Lacquers or pellets shall be used.</p> <p>3. For tubes supplied in bend condition, tube thinning shall be governed by the following formula.</p> $t = t_o \times (1 + d/4R) \quad \text{where}$ <p>t = Specified minimum wall tube thickness.</p> <p>t_o = Thickness after bending.</p> <p>D = Outside diameter of tube.</p> <p>R = Center line bend radius.</p> <p>4. Minimum thickness, ovality etc., achieved for minimum bend radius tube for each thickness shall be proved.</p> <p>5. Hot bending to form U tubes shall not be acceptable.</p> <p>6. The tubes shall be tested for corrosion resisting properties as follows :</p> <p>a) One full section sample 1 inch (25.4mm) long from the center of a sample tube of the smallest radius bend which is heat treated shall be tested in the heat treated condition in accordance with practices A262, practice-E.</p>					
Ref.Doc	Revisions: Refer to record of revisions	Prepared: 	Approved 	Date: 06.05.2004	

COPYRIGHT AND CONFIDENTIAL
 The information on this document is the property of BHARAT HEAVY ELECTRICALS LIMITED.
 It must not be used directly or indirectly in any way detrimental to the interest of the company

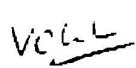
TD-106-2 Rev-5	Form No.		PRODUCT STANDARD HEAT EXCHANGERS HYDERABAD		No: HE 5 1173
<p style="text-align: center;">COPYRIGHT AND CONFIDENTIAL</p> <p>The information on this document is the property of BHARAT HEAVY ELECTRICALS LIMITED. It must not be used directly or indirectly in any way detrimental to the interest of the company</p>			<p>b) One full section sample 1 inch (25.4mm) long from each lot (“lot” refers to all tubes prior to cutting to length, of the same Nominal dia, and wall thickness, produced from the same heat of steel and annealed in a continuous furnace at the same temperature, time at heat , and furnace speed) of straight tubes shall be tested in the finished condition in accordance with practices A262, practice-E.</p> <p>c) The appearance of any fissures or cracks in the test specimen when evaluated in accordance with practices A262, practice-E. indicating the presence of inter granular attack, shall be cause for rejection of that lot.</p> <p>7. Eddy current test shall be carried out as per E426. Eddy Current testing to be carried out 100% online OR 100% Offline which shall be witnessed by BHEL/BHEL nominated inspection agency (BHEL TPIA) with quantum of inspection 100%. (The The type of notch and acceptance norm shall be Transverse tangential notch as per SA1016.)</p> <p>7a. Flaring test on each lot, atleast two tests from each lot are to be conducted as per SA1016.</p> <p>8. Permissible variation from the specified outside diameter shall not exceed ± 0.1 mm for stainless steel tubes (seamless). This includes ovality also.</p> <p>9. Permissible variations from the specified wall thickness.</p> <p>a) Permissible variations from the specified minimum wall thickness shall not exceed +20% - 0.</p> <p>b) Permissible variation from the specified average wall thickness are $\pm 10\%$ of the nominal wall thickness.</p> <p>10. At the bend portion of the U-tube for $R=1.5x d$ or greater neither the major nor minor diameter of tube shall deviate from nominal prior to bending by more than 10%.</p> <p>11. Leg spacing measuring between the points of tangency of the bend to the legs shall not vary from the value (2R- specified tube O.D) by more than 1.5 mm. Where ‘R’ is the center line bend radius.</p> <p>12. The bend portion of the U-tube shall be substantially uniform in curvature and not exceed the normal center line radius by ± 1.5 mm.</p> <p>13. Permissible deviation from the plane of bend shall not exceed 1.5 mm as measured from point of tangency.</p> <p>14. Each tube shall be subjected to the hydrostatic test by DM water with a chloride content not exceeding 10 PPM, to the pressure indicated in the drawing / enquiry / P.O.</p> <p>15. Manufacturing, inspection, testing, certification & marking shall fully confirm to SA 213 TP 304 / TP 304L/ TP 304N/ TP 316 (as per drawing /enquiry / P.O) of ASME SEC II PART A, year of edition and addenda as indicated in drawing / enquiry / P.O and as per this standard.</p> <p>16. Packing shall be seaworthy and capable of withstanding mechanical damage. Tube ends shall be capped or plugged for protection against ingress of moisture / water during transit & storage. Supplier shall submit packing procedure with sketch of packing box along with the offer for BHEL’s approval.</p>		REV. NO. 10
			Page 2 of 4		
			Ref.Doc	Revisions: Refer to record of revisions	Prepared: 

TD-106-2 Rev-5	Form No.		PRODUCT STANDARD HEAT EXCHANGERS HYDERABAD		No: HE 5 1173
					REV. NO. 10
					Page 3 of 4
<p style="writing-mode: vertical-rl; transform: rotate(180deg);"> COPYRIGHT AND CONFIDENTIAL The information on this document is the property of BHARAT HEAVY ELECTRICALS LIMITED. It must not be used directly or indirectly in any way detrimental to the interest of the company </p> <p> 17. Supplier shall furnish test certificates in 6 copies. Test certificates shall contain the following information duly attested by BHEL Approved Third Party Inspection Agency, Additionally by Director Of Boilers for H.P. Heaters in case of indigenous supplies. </p> <ul style="list-style-type: none"> a) Purchase order No and Grade b) Specification No and Grade c) Heat No and Heat analysis d) Product analysis e) Size, thickness and quantity of tubes f) Results of all test as per specification & as per this standard carried out with BHEL Approved Third Party Inspection Agency. <p> 18. Tubes inside & Outside surfaces shall be tested for residual chloride salt contamination to limits as per SA 688. The same shall be reported in Test Certificates. Procedure of measuring residual chloride contamination shall be furnished. </p> <p> 19. Cleanliness of inside surface of all U tube shall be confirmed by blowing close fitting acetone soaked felt plugs. Inert gas or N2 shall be used for blowing. </p> <p> 20. In the event of an order supplier shall furnish annealing procedure in advance for approval and also furnish co-related TC with all relevant details of heat treatment in accordance with approved procedure. </p> <p> 21. ---- 22. ---- </p> <p> 23. Packing & Marking for U tubes – AA 049003. 24. Packing & Marking for Straight Tubes – AA049002. </p> <p> 25. Inspection and certification : </p> <ul style="list-style-type: none"> i) H.P.HEATERS: <ul style="list-style-type: none"> a) where the material is sourced from suppliers other than India ,the certification shall be in IBR form III B duly signed by BHEL Approved Third Party Inspection Agency(BHEL TPIA).BHEL TPIA shall be authorised by Central Boiler Board for that country. b) Where the material is sourced from Indigenous Suppliers, the certification shall be by Director of Boilers in form III B and also by BHEL Approved Third Party Inspection Agency(BHEL TPIA) as per ASME SEC.II Part A.Edition & Addenda as indicated in the drawing/P.O & enclosed quality plan. ii) L.P.HEATERS & DRAIN COOLER: <ul style="list-style-type: none"> a) Inspection & Certification shall be by BHEL Approved Third party Inspection Agency(BHEL TPIA) as per ASME SEC.II Part A. Edition & Addenda as indicated in the drawing/P.O & enclosed quality plan. 					
Ref.Doc	Revisions: Refer to record of revisions	Prepared: 	Approved 	Date: 06.05.2004	

SL NO	COMPONENTS	CHARACTERISTICS	CLASS	TYPE OF CHECK	QUANTUM OF CHECK	REFERENCE DOCUMENT	ACCEPTANCE NORMS	FORMAT OF RECORD	*	AGENCY			REMARKS
										D	S	M	
 BHEL HYDERABAD-32										STANDARD QUALITY PLAN ITEM: SEAMLESS SS 'U' TUBES FOR HP HEATERS & LP HEATERS			QP No. : HY/HE/010/U-TUBE Rev. No.: 02 DATE : 21.12.2013 PAGE : 1 OF 3
1.0	RAW MATERIAL INSPECTION												
1.1	Mother tubes	a) Identification of mother tubes markings w.r.to TC	Major	Visual	100%	Test Certificate	BHEL Specification	TC & Inspn. Record		P	V	V	
		b) Visual & Dimn. Exam	-do-	Visual & Measurt.	-do-	-do-	-do-	-do-		P	V	V	
1.2	Verification of mother tubes Test Certificate	a) Chemical comp.	-do-	-do-	-do-	-do-	-do-	-do-	✓		P	V	Carbon content limit shall be as per BHEL Specification
		b) Mech. Properties	-do-	-do-	-do-	-do-	-do-	-do-	✓		P	V	
2.0	IN PROCESS INSPECTION												
2.1	Pilgering / Intermediate drawing	Solution annealing after pilgering / drawing	Major	Heat treatment	100%	-do-	-do-	-do-			P		
2.2	Tube washing	Surface condition	Major	Visual	100%	-do-	-do-	-do-			P		
2.3	Final drawing	Bright Annealing in inert atmosphere	Major	Heat treatment	100%	-do-	-do-	HT Chart	✓		P	V	Note 3
2.4	Final sizing	OD & surface condition	Major	Measurt.	100%	BHEL Specification	BHEL Specification	Inspn. Record			P		
2.5	Straightening	Straightness	Major	Visual	100%	-do-	-do-	-do-			P		
2.6	Eddy Current test	Internal flaws	-do-	NDE	-do-	ASTM E426	ASME SA1016 & Note 8	Supplier TC	✓		P	W*	*100% online OR 100% offline
2.7	Cut to length with allowance	Length	Major	Measurt	100%	BHEL Specification & PO	BHEL Specification & PO	Inspn. Record			P		
2.8	Inspection of straight tubes	OD, Thickness, Length, Straightness, Edge burrs., surface condition	Major	Visual & Measurt.	-do	Mfr. Std.	Mfr. Std.	-do-			P	V	

BHEL Drg No. : As per P.O.	BHEL Spec. No.: HE 51173 Rev. 10	PREPARED BY: <i>gtsk</i> G T S K Dakshina Murthy Engr./QA	APPROVED BY: <i>Y C Venkateswara Rao</i> Y C Venkateswara Rao Sr.DGM/QA
Legend: *D- Documents marked (✓) to be included by Supplier in Doc. Package. S - Sub Vendor P - Perform C of C : Certificate of Compliance M - Vendor / Manufacturer W - Witness Mfr. : Manufacturer C - BHEL/ Inspn. Agency V - Verify Measurt.: Measurement			

BHEL HYDERABAD-32		STANDARD QUALITY PLAN						QP No. : HY/HE/010/U-TUBE Rev. No.: 02 DATE : 21.12.2013 PAGE : 2 OF 3					
		ITEM: SEAMLESS SS 'U' TUBES FOR HP HEATERS & LP HEATERS											
SL NO	COMPONENTS	CHARACTERISTICS	CLASS	TYPE OF CHECK	QUANTUM OF CHECK	REFERENCE DOCUMENT	ACCEPTANCE NORMS	FORMAT OF RECORD	*	AGENCY			REMARKS
										D	S	M	
2.9	U-bending of tubes	Centre line bend radius (CLR)	Major	Visual	100%	Mfr. Std.	Mfr. Std.	Inspn. Record			P	V	Note 4
2.10	U-bending of tubes	Wall thinning	Major	Measurt	1 sample of minimum bend radius for each thickness	BHEL Specification & Drg.	BHEL Specification & Drg.	Inspn. Record			P	V	
2.11	Stress relieving of U- bend portion	Solution Annealing	Major	Visual	100%	SA213, PO	SA 213, PO	Inspn. Record			P	V	Note 5
3.0	FINAL INSPECTION												
3.1	Hydrostatic testing	Pressure, Time, Leakage	-do-	Visual	-do-	ASTM A1016	ASTM A1016	Supplier TC	✓		P	W	CHP, Note 6
3.2	Cut to length & deburr	Length, edge condition	Major	Measurt	100%	BHEL Specification & PO	BHEL Specification & PO	Inspn. Record			P	V	
3.3	Dimn. conformity & visual exam.	OD, CLR, thickness, Length, ovality, leg spacing, plane of bend, curvature, edge burrs.	Major	Measurt.	-do	Drg. / PO	Drg. / PO	-do-	✓		P	W*	* Verify & Random witness
3.4	Test on Tubes	a) Chemical composition	Major	Chemical	As per Spec.	SA213, SA1016 & PO	SA213, SA1016 & PO	Suppliers TC	✓		P	V	Carbon content limit shall be as per BHEL Specification
		b) Tensile testing	-do-	Mech.	-do	-do-	-do-	-do-	✓		P	W	
		c) Hardness testing	-do-	Mech.	-do	-do-	-do-	-do-	✓		P	W	
		d) Reverse Bend test	-do-	Mech.	-do	-do-	-do-	-do-	✓		P	W	
		e) Flattening test	-do-	Mech.	-do	-do-	-do-	-do-	✓		P	W	
		f) Flaring test	-do-	Mech.	-do	-do-	-do-	-do-	✓		P	W	
BHEL Drg No. : As per P.O.			BHEL Spec. No.: HE 51173 Rev. 10			PREPARED BY: <i>G T S K Dakshina Murthy</i> G T S K Dakshina Murthy Engr./QA			APPROVED BY: <i>Y C Venkateswara Rao</i> Y C Venkateswara Rao Sr.DGM/QA				
Legend: *D- Documents marked (✓) to be included by Supplier in Doc. Package. S - Sub Vendor P - Perform C of C : Certificate of Compliance M -Vendor / Manufacturer W - Witness Mfr. : Manufacturer C - BHEL/ Inspn. Agency V - Verify Measurt. : Measurement													

BHEL HYDERABAD-32		STANDARD QUALITY PLAN						QP No. : HY/HE/010/U-TUBE Rev. No.: 02 DATE : 21.12.2013 PAGE : 3 OF 3					
ITEM: SEAMLESS SS 'U' TUBES FOR HP HEATERS & LP HEATERS													
SL NO	COMPONENTS	CHARACTERISTICS	CLASS	TYPE OF CHECK	QUANTUM OF CHECK	REFERENCE DOCUMENT	ACCEPTANCE NORMS	FORMAT OF RECORD	* D	AGENCY			REMARKS
										S	M	C	
		g) Flanging test	-do-	Mech.	-do	-do-	-do-	-do-	✓		P	W	
		h) Inter granular corrosion testing	-do-	Met.	-do	-do-	-do-	-do-	✓		P	V	
		i) Residual Chloride	-do-	Chem.	-do	-do-	-do-	Inspn. Record	✓		P	V	
		j) Residual circumferential stress	-do-	Measurt	One specimen per lot	PO & Drg.	PO & Drg.	Inspn. Record			P	W	Procedure for residual stress measurement as approved by BHEL to be followed
4.0	Packing & despatch	Verification of all TCs for completion.	Major	Visual	100%	PO, Spec., Drg. & QP	-do-	-do-			P	V	
		Cleanliness of inside surface of tubes	Major	Visual	100%	BHEL Specification	BHEL Specification	-do-			P	V	
		Identification, preservation & packing	Major	Visual	100%	PO / Drg	PO / Drg	Inspn. Record			P	V	Note 7

Notes:

- Lubricants used in tube drawing operation shall be non-chlorinated (50 ppm chlorides or less). All cleaning compounds shall be chloride and caustic free. Each cleaning operation shall be followed by a rinse or rinses with water, the final rinse shall be with demineralised water containing not more than 10 ppm chlorides.
- Intermediate solution annealing shall also be done in Bright Annealing furnace only.
- Straight tubes shall be cleaned and bright annealed at a temperature of 1040°C min. followed by quenching to below 370° C.
- Hot bending to form 'U' tubes shall not be permitted.
- U bend area plus approximately 150mm of each leg beyond tangent point of the U bend shall be heat treated.
- Hydrostatic testing of tubes shall be carried out with demineralised water. Chloride content of D.M. water shall not exceed 10ppm.
- Tubes shall be packed in sea worthy packing & shall be capable of with standing mechanical damages during transit.
- Eddy current test shall be carried out with a transverse tangential notch as per SA1016
- Project specific requirements, if any, as per P.O. shall also be complied with.
- The required certification for HP Heater U-tubes from IBR in IBR form III B format shall be furnished to BHEL.

BHEL Drg No. : As per P.O.	BHEL Spec. No.: HE 51173 Rev. 10	PREPARED BY: <i>fumom</i>	APPROVED BY: <i>Y C Venkateswara Rao</i>
Legend: *D- Documents marked (✓) to be included by Supplier in Doc. Package. S - Sub Vendor P - Perform C of C : Certificate of Compliance M - Vendor / Manufacturer W - Witness Mfr. : Manufacturer C - BHEL/ Inspn. Agency V - Verify Measurt.: Measurement		G T S K Dakshina Murthy Engr./QA	Y C Venkateswara Rao Sr.DGM/QA

INTEGRITY PACT

Between

Bharat Heavy Electricals Ltd. (BHEL), a company registered under the Companies Act 1956 and having its registered office at "BHEL House", Siri Fort, New Delhi – 110049 (India) hereinafter referred to as "The Principal", which expression unless repugnant to the context or meaning hereof shall include its successors or assigns of the ONE PART

and

_____, (description of the party along with address), hereinafter referred to as "The Bidder/ Contractor" which expression unless repugnant to the context or meaning hereof shall include its successors or assigns of the OTHER PART

Preamble

The Principal intends to award, under laid-down organizational procedures, contract/s for

_____. The Principal values full compliance with all relevant laws of the land, rules and regulations, and the principles of economic use of resources, and of fairness and transparency in its relations with its Bidder(s)/ Contractor(s).

In order to achieve these goals, the Principal will appoint Independent External Monitor(s), who will monitor the tender process and the execution of the contract for compliance with the principles mentioned above.

Section 1 – Commitments of the Principal

- 1.1 The Principal commits itself to take all measures necessary to prevent corruption and to observe the following principles:-
 - 1.1.1 No employee of the Principal, personally or through family members, will in connection with the tender for, or the execution of a contract, demand, take a promise for or accept, for self or third person, any material or immaterial benefit which the person is not legally entitled to.
 - 1.1.2 The Principal will, during the tender process treat all Bidder(s) with equity and reason. The Principal will in particular, before and during the tender process, provide to all Bidder(s) the same information and will not provide to any Bidder(s) confidential / additional information through which the Bidder(s) could obtain an advantage in relation to the tender process or the contract execution.
 - 1.1.3 The Principal will exclude from the process all known prejudiced persons.
- 1.2 If the Principal obtains information on the conduct of any of its employees which is a penal offence under the Indian Penal Code 1860 and Prevention of Corruption Act 1988 or any other statutory penal enactment, or if there be a substantive suspicion in this regard, the Principal will inform its Vigilance Office and in addition can initiate disciplinary actions.

Section 2 – Commitments of the Bidder(s)/ Contractor(s)

- 2.1 The Bidder(s)/ Contractor(s) commit himself to take all measures necessary to prevent corruption. He commits himself to observe the following principles during his participation in the tender process and during the contract execution.
 - 2.1.1 The Bidder(s)/ Contractor(s) will not, directly or through any other person or firm, offer, promise or give to the Principal or to any of the Principal's employees involved

in the tender process or the execution of the contract or to any third person any material, immaterial or any other benefit which he / she is not legally entitled to, in order to obtain in exchange any advantage of any kind whatsoever during the tender process or during the execution of the contract.

- 2.1.2 The Bidder(s)/ Contractor(s) will not enter with other Bidder(s) into any illegal or undisclosed agreement or understanding, whether formal or informal. This applies in particular to prices, specifications, certifications, subsidiary contracts, submission or non-submission of bids or any other actions to restrict competitiveness or to introduce cartelization in the bidding process.
- 2.1.3 The Bidder(s)/ Contractor(s) will not commit any penal offence under the relevant IPC/ PC Act; further the Bidder(s)/ Contractor(s) will not use improperly, for purposes of competition or personal gain, or pass on to others, any information or document provided by the Principal as part of the business relationship, regarding plans, technical proposals and business details, including information contained or transmitted electronically.
- 2.1.4 The Bidder(s)/ Contractor(s) will, when presenting his bid, disclose any and all payments he has made, and is committed to or intends to make to agents, brokers or any other intermediaries in connection with the award of the contract.
- 2.2 The Bidder(s)/ Contractor(s) will not instigate third persons to commit offences outlined above or be an accessory to such offences.

Section 3 – Disqualification from tender process and exclusion from future contracts

If the Bidder(s)/ Contractor(s), before award or during execution has committed a transgression through a violation of Section 2 above, or acts in any other manner such as to put his reliability or credibility in question, the Principal is entitled to disqualify the Bidder(s)/ Contractor(s) from the tender process or take action as per the separate "Guidelines on Banning of Business dealings with Suppliers/ Contractors". framed by the Principal.

Section 4 – Compensation for Damages

- 4.1 If the Principal has disqualified the Bidder from the tender process prior to the award according to Section 3, the Principal is entitled to demand and recover the damages equivalent Earnest Money Deposit/Bid Security.
- 4.2 If the Principal has terminated the contract according to Section 3, or if the Principal is entitled to terminate the contract according to section 3, the Principal shall be entitled to demand and recover from the Contractor liquidated damages equivalent to 5% of the contract value or the amount equivalent to Security Deposit/Performance Bank Guarantee, whichever is higher.

Section 5 – Previous Transgression

- 5.1 The Bidder declares that no previous transgressions occurred in the last 3 years with any other company in any country conforming to the anti-corruption approach or with any other Public Sector Enterprise in India that could justify his exclusion from the tender process.
- 5.2 If the Bidder makes incorrect statement on this subject, he can be disqualified from the tender process or the contract, if already awarded, can be terminated for such reason.

Section 6 – Equal treatment of all Bidders/ Contractors/ Sub-contractors

- 6.1 The Bidder(s)/ Contractor(s) undertake(s) to obtain from all subcontractors a commitment consistent with this Integrity Pact and report Compliance to the Principal. This commitment shall be taken only from those sub-contractors whose contract value is more than 20 % of Bidder's/ Contractor's contract value with the Principal. The Bidder(s)/ Contractor(s) shall continue to remain responsible for any default by his Sub-contractor(s).
- 6.2 The Principal will enter into agreements with identical conditions as this one with all Bidders and Contractors.
- 6.3 The Principal will disqualify from the tender process all bidders who do not sign this pact or violate its provisions.

Section 7 – Criminal Charges against violating Bidders/ Contractors /Sub-contractors

If the Principal obtains knowledge of conduct of a Bidder, Contractor or Subcontractor, or of an employee or a representative or an associate of a Bidder, Contractor or Subcontractor which constitutes corruption, or if the Principal has substantive suspicion in this regard, the Principal will inform the Vigilance Office.

Section 8 –Independent External Monitor(s)

- 8.1 The Principal appoints competent and credible Independent External Monitor for this Pact. The task of the Monitor is to review independently and objectively, whether and to what extent the parties comply with the obligations under this agreement.

- 8.2 The Monitor is not subject to instructions by the representatives of the parties and performs his functions neutrally and independently. He reports to the CMD, BHEL.
- 8.3 The Bidder(s)/ Contractor(s) accepts that the Monitor has the right to access without restriction to all contract documentation of the Principal including that provided by the Bidder(s)/ Contractor(s). The Bidder(s)/ Contractor(s) will grant the monitor, upon his request and demonstration of a valid interest, unrestricted and unconditional access to his contract documentation. The same is applicable to Sub-contractor(s). The Monitor is under contractual obligation to treat the information and documents of the Bidder(s)/ Contractor(s) / Sub-contractor(s) with confidentiality.
- 8.4 The Principal will provide to the Monitor sufficient information about all meetings among the parties related to the contract provided such meetings could have an impact on the contractual relations between the Principal and the Contractor. The parties offer to the Monitor the option to participate in such meetings.
- 8.5 As soon as the Monitor notices, or believes to notice, a violation of this agreement, he will so inform the Management of the Principal and request the Management to discontinue or take corrective action, or heal the situation, or to take other relevant action. The Monitor can in this regard submit non-binding recommendations. Beyond this, the Monitor has no right to demand from the parties that they act in a specific manner, refrain from action or tolerate action.
- 8.6 The Monitor will submit a written report to the CMD, BHEL within 8 to 10 weeks from the date of reference or intimation to him by the Principal and, should the occasion arise, submit proposals for correcting problematic situations.
- 8.7 The CMD, BHEL shall decide the compensation to be paid to the Monitor and its terms and conditions.
- 8.8 If the Monitor has reported to the CMD, BHEL, a substantiated suspicion of an offence under relevant IPC / PC Act, and the CMD, BHEL has not, within reasonable time, taken visible action to proceed against such offence or reported it to the Vigilance Office, the

Monitor may also transmit this information directly to the Central Vigilance Commissioner, Government of India.

8.9 The number of Independent External Monitor(s) shall be decided by the CMD, BHEL.

8.10 The word 'Monitor' would include both singular and plural.

Section 9 – Pact Duration

9.1 This Pact begins and shall be binding on and from the submission of bid(s) by bidder(s). It expires for the Contractor 12 months after the last payment under the respective contract and for all other Bidders 6 months after the contract has been awarded.

9.2 If any claim is made / lodged during this time, the same shall be binding and continue to be valid despite the lapse of this pact as specified as above, unless it is discharged/ determined by the CMD, BHEL.

Section 10 – Other Provisions

10.1 This agreement is subject to Indian Laws and jurisdiction shall be registered office of the Principal, i.e. New Delhi.

10.2 Changes and supplements as well as termination notices need to be made in writing. Side agreements have not been made.

10.3 If the Contractor is a partnership or a consortium, this agreement must be signed by all partners or consortium members.

10.4 Should one or several provisions of this agreement turn out to be invalid, the remainder of this agreement remains valid. In this case, the parties will strive to come to an agreement to their original intentions.

10.5 Only those bidders/ contractors who have entered into this agreement with the Principal would be competent to participate in the bidding. In other words, entering into this agreement would be a preliminary qualification.

For & On behalf of the Principal

For & On behalf of the Bidder/ Contractor

(Office Seal)

(Office Seal)

Place-----

Date-----

Witness: _____

Witness: _____

(Name & Address) _____

(Name & Address) _____



BHARAT HEAVY ELECTRICALS LTD. , RC.PURAM, HYDERABAD
General Conditions of Contract for Purchase (GCC)

1. **Applicable Conditions:** These General Conditions of Contract for Purchase apply to all enquiries, tenders, requests for quotations, orders and agreements concerning the supply of goods and the rendering of related services (hereinafter referred to as "deliverables") to Bharat Heavy Electricals Limited, Ramachandrapuram, Hyderabad (hereinafter referred to as "BHEL" or the Purchaser) or its projects/customers.
Any deviations from or additions to these 'General Conditions of Contract for Purchase' require Purchaser's express written consent. The general terms of business or sale of the Seller shall not apply to Purchaser.
Orders, agreements and amendments thereto shall be binding if made or confirmed by the Purchaser in writing. Only the Purchasing department of the Purchaser is authorized to issue the Purchase Order or any amendment thereof.
2. **Definitions**
Throughout these conditions and in the specifications, the following terms shall have the meanings assigned to them, unless the subject matter or the context requires otherwise.
 - 2.1 **'The Purchaser'** means BHEL, Ramachandrapuram, Hyderabad-502 032 of Bharat Heavy Electricals Limited (A Govt. of India Undertaking) incorporated under the Companies Act having its registered office at BHEL House, Siri Fort, New Delhi-110049, India and shall be deemed to include its successors and assigns. It may also be referred to as BHEL.
 - 2.2 **'The Seller'** means the person, firm, company or organization on whom the Purchase Order is placed and shall be deemed to include the seller's successors, representatives, heirs, executors and administrator as the case may be. It may also be referred to as Contractor, Supplier or Vendor.
 - 2.3 **'Contract'** shall mean and include the Purchase Order incorporating various documents viz. tender/offer, letter of intent/ acceptance, the General Conditions of Contract and Special Conditions of Contract for Purchase, Specifications, Inspection/ Quality Plan, Schedule of Prices and Quantities, Drawings, if any enclosed or to be provided by the Purchaser or his authorized nominee and the samples or patterns if any to be provided under the provisions of the Contract.
In case of any inconsistency or contradiction between any of the documents, the order of precedence shall be Purchase Order, LOI/ LOA followed by: specific conditions, Special Conditions of Contract and General Conditions of Contract for commercial conditions; and specific agreement on technical conditions, Special Technical Conditions and General Technical conditions, tender/ offer.
 - 2.4 **'Parties to the Contract'** shall mean the Seller and the Purchaser as named in the main body of the Purchase Order.
3. **Ordering and Confirmation of Order**
The Seller shall send the order Acceptance within two weeks from the date of LOI/ Purchase Order or such other period as specified/ agreed by the Purchaser. Purchaser reserves the right to revoke the order placed If the order confirmation differs from the original order placed, Purchaser shall only be legally bound if agreed explicitly in writing to be in agreement with the deviation. The acceptance of deliverables or supplies by Purchaser as well as payments made in this regard shall not imply acceptance of any deviations.



The purchase order will be deemed to have been accepted if no communication to the contrary is received within two weeks (or the time limit as specified/ agreed by the Purchaser) from the date of PO.

Purchaser, is at liberty to send signed PO through electronic media such as e-mail and the receipt of which shall be treated as receipt of order.

4. Execution

The whole contract is to be executed in the most approved, substantial and workman like manner as per the contracted terms.

5. Progress Report

The Seller shall render such report as to the progress of work and in such form as may be called for by the Purchaser from time to time. The submission and acceptance of such reports shall not prejudice the rights of the Purchaser in any manner.

6. Product Information, Drawings and Documents

Drawings, technical documents or other technical information received by one party shall not, without the consent of the other party, be used for any other purpose than that for which they were provided. They may not, without the consent of the submitting party, otherwise be used or copied, reproduced, transmitted or communicated to third parties. All information and data contained in general product documentation, whether in electronic or any other form, are confidential and binding only to the extent that they are by reference expressly included in the Contract.

The Seller shall, as per agreed date/s but not later than the date of delivery, provide free of charge any information and/or drawings which are necessary to permit the Purchaser to erect, commission, operate and maintain the product. Such information and drawings shall be supplied in the number of copies agreed upon or at least three copies of each.

All intellectual properties, including designs, drawings and product information etc. exchanged during the formation and execution of the Contract shall continue to be the property of the submitting party.

7. Non-disclosure and Information Obligations

The Seller shall provide Purchaser with all information pertaining to the delivery in so far as it could be of importance to Purchaser. The Seller shall not reveal confidential information to its own employees not involved with the tender/ Contract & its execution and delivery or to third parties, unless Purchaser has agreed to this in writing beforehand. The Seller shall not be entitled to use the Purchaser's name in advertisements and other commercial publications including website without prior written permission from Purchaser.

In the event of violation of the confidentiality as agreed, BHEL will take legal action as deemed fit.

8. Inspection and Testing

- 8.1 The goods and stores shall be of approved design and each part/ component may be inspected and tested by the Purchaser prior to shipment and shall fully comply with relevant requirements of Purchaser.



Purchaser has the right to inspect the delivery. In the event of rejection, Purchaser shall inform the Seller accordingly and Purchaser shall be entitled to replacement or repair at its discretion or may proceed to terminate or annul the agreement. All this does not affect Purchaser's right to recover compensation.

- 8.2 Purchaser or his authorized representative shall be entitled at all reasonable times during execution to inspect, examine and test at the Seller's premises the material and workmanship of all stores to be supplied under the Contract, and if the part of the stores are being manufactured at other premises the Seller shall obtain for Purchaser or his authorized representative permission to inspect, examine and test as if the said stores are being manufactured at the Seller's premises. Such inspection, examination and testing, if made shall not release the Seller from any obligation under the Contract.

All costs related to inspections and re-inspections shall be borne by the Seller. The cost of inspection staff/ third party specified by the Purchaser shall be borne by seller unless otherwise specifically agreed. Whether the Contract provides for tests on the premises of the Seller or any of his Sub-contractor/s, Seller shall be responsible to provide such assistance, labour, materials, electricity, fuels, stores, apparatus, instruments as may be required and as may be reasonably demanded to carry out such tests efficiently.

Cost of any type test or such other special tests shall be borne by the Seller unless otherwise specifically agreed in the contract.

- 8.3 The Seller shall give the authorized representative of the Purchaser reasonable notice in writing of the date on and the place at which any stores will be ready for inspection/ testing as provided in the Contract.

9. **Quality and Condition of the Deliverables**

The Seller shall be responsible for compliance with applicable technical, safety, quality, environmental requirements and other regulations in relation to his products, packaging, and raw and ancillary materials.

10. **Packaging and Dispatch**

The Seller shall package the deliverables safely and carefully and pack them suitably in all respects considering the peculiarity of the material for normal safe transport by Sea/ Air / Rail/ Road to its destination suitably protected against loss, damage, corrosion in transit and the effect of tropical salt laden atmosphere. The packages shall be provided with fixtures/ hooks and sling marks as may be required for easy and safe handling by mechanical means.

Each package must be marked with Consignee name, P.O Number, Package No., Gross weight & Net weight, Dimensions (LxBxH) and Seller's name. The packing shall allow for easy removal and checking of goods on receipt and comply with carrier's conditions of packing or established trade practices. Packing list of goods inside each package with PO item no. & Quantity must also be fixed securely outside the box to indicate the contents. If any consignment needs special handling instruction, the same shall be clearly marked with standard symbols / instructions. Hazardous material should be notified as such and their packing, transportation and other protection must conform to relevant regulations.

11. **Delivery**

Except as otherwise indicated in the Purchase Order, delivery shall be FOR (Destination) for indigenous orders and FOB-Port of Export/FCA for imported orders. Trade terms such as EXW,



CFR etc., if stipulated in the order shall be construed in accordance with the version of the INCOTERMS applicable at the time of ordering, without prejudice to the provisions contained in these conditions. The delivery date(s) or delivery period(s) as stipulated in the agreement shall be firm and binding and shall apply to the entire delivery for each PO item. Partial shipments may, however, be permitted by the purchaser.

Unless specifically agreed otherwise, transit insurance coverage for imported consignments is taken by BHEL. Accordingly, the Seller shall send an intimation to the Purchase Officer/ Manager giving Purchase Order No., Shipping particulars, Invoice Value etc. immediately on dispatch of goods.

12. **Penalty:**

The time or period of delivery as stipulated in the schedule of delivery shall be deemed to be the essence of the Contract. Should circumstances arise whereby the deadline for an agreed delivery date(s) or period(s) is expected to be exceeded, the Seller shall inform Purchaser hereof without delay. If delay in delivery is caused by any of the circumstances mentioned in Clause 21 (Force Majeure) or which are caused exclusively by the acts of Purchaser, the Purchaser shall extend the time for delivery by a period which is reasonable having regard to all the circumstances in the case.

If the Seller delays beyond any agreed delivery date(s) or period(s), Purchaser shall levy penalty for such delay @ 0.5 % per week (7 days) or part thereof on delayed portion of the order value subject to a maximum of 10% of the value of the Purchase Order. However, Penalty for delayed delivery will be calculated on 100% of the purchase order value if the material supplied cannot be put to intended use.

The Penalty will be charged on the value of the purchase order excluding statutory levies, freight and insurance wherever not included in the price.

Imposition, recovery or settlement of this penalty shall not affect Purchaser's right to performance, compensation and termination of the agreement.

13. **Transfer of Ownership and Risk**

The risk for the delivery remains with the Seller until the goods are delivered at the agreed place.

14. **Price, Invoicing and Payment**

The agreed prices are fixed prices in the currency as specified in the Purchase Order. They shall include packing, forwarding, loading and carriage to the place specified by the Purchaser and are exclusive of all applicable taxes, duties etc. except for those specifically agreed by the Purchaser. Invoices shall be submitted bearing the Purchase Order number & date, item number/s and supporting documents as called for in the Purchase Order.

The direct payments (excluding LC/documents through Bank on collection basis), shall be made by E-payment mode and not by cheque/ Bank Drafts except in special circumstances. Vendors shall furnish the E-payment particulars in the prescribed formats duly authenticated by their respective Bankers, if not got registered earlier with the Buyer.

Indian Agency commission if payable and so specified in the Purchase Order shall be paid in Indian Rupees, considering the SBI TT selling exchange rate prevailing on the date of tender opening (Part I in case of two part bid) , after successful completion of the contract.



If so stipulated in the order, the Seller shall furnish, on receipt of the Purchase Order or along with order acknowledgement, the Billing break-up of prices (BBU) for approval by the Purchaser in respect of the major items/ components going into the equipment. This BBU is required by the Purchaser for admitting the claims of the Seller if part shipments are contemplated and also to facilitate custom clearance after payment of duties in case of imports.

Purchaser shall be entitled to suspend payment for as long as required supporting documents/ details remain outstanding and any consequential demurrage/ wharfage shall be to the account of the Seller.

Payment does not imply in any respect whatsoever a waiver of Purchaser's right to performance of the agreement. Purchaser is entitled to set off claimable debts against claimable liabilities with the Seller by means of a setoff note.

15. Contract Variations; Increase or Decrease in the Scope of Supply

Purchaser may vary the contracted scope during execution due to exigencies of project requirement.

If the Seller is of the opinion that the variation has an effect on the agreed price or delivery period, Purchaser shall be informed of this immediately in writing along with technical details, and in the event of additional work, submit a quotation with regards to the price and period involved, as well as the effect this additional work will have on the other work to be performed by the Seller. Provided, however, that if unit rates are available in the Contract, the same shall be applied to such additional work. The Seller shall not perform additional work before Purchaser has issued written instructions/ amendment to the Purchase Order to that effect. The work which the Seller should have or could have anticipated in terms of delivering the service(s) and functionality (ies) as described in this agreement and hence to be executed by the vendor without any price implication.

16. Guarantee/ Warranty

Wherever required, and so provided in the specifications/ Purchaser Order, the Seller shall guarantee that the goods supplied shall comply with the specifications laid down, for materials, workmanship and performance. If within the guarantee period the delivery is found to be non-compliant, the Seller shall, for its own account, replace, repair, or re-execute the delivery at Purchaser's discretion when first requested to do so within mutually agreed period, without prejudice to Purchaser's other legal rights. If the Seller continues to default on its obligations, Purchaser has the right to proceed to replace, repair or re-execute the order at the Seller's expense, with or without help from third parties. Purchaser shall notify the Seller of the exercise of this right in advance where possible.

Unless otherwise specified, guarantee period shall be 12 months from the date of commissioning or 18 months from the date of supply whichever is earlier. For capital goods or bought out packages which are intended to be incorporated in installations or systems the Guarantee period shall not start until the time the installations or systems are commissioned, provided always that the period ends not later than 30 months after the date of supply of the goods.

The guarantee period shall be extended by the period during which the goods are not in compliance. A guarantee period as described above shall apply afresh to replaced, repaired or re-executed parts of a delivery.



17. Short Shipments / Warranty / Guarantee Replacements

In case of any short shipments during initial supply, subsequently dispatched by the Seller or as any Guarantee/ Warranty replacement shall be dispatched on "DDP – Delivered Duty Paid BHEL Stores" basis for imported items and "FOR – BHEL Stores/ designated destination" basis for indigenous items. Taxes and duties, if any, paid by indigenous vendor for short supply/guarantee and warranty replacement, repair activity shall be to vendor's account only.

18. Rejection/ Replacement

The Seller shall arrange replacement / repair under its obligation under the contract within one month from the date of intimation or mutually agreed period. The rejected goods shall be taken away by the seller and replaced on DDP/ FOR - BHEL Stores/ designated destination basis within such period. In the event of the Seller's failure to comply, Purchaser may take appropriate action including disposal of rejections, at the cost and risk of the Seller.

In case defects attributable to Seller are detected during processing of the goods at purchaser's / his subcontractor works, the Seller shall be responsible for replacement/ repair of the goods as required by the purchaser at Seller's cost.

19. Export Administration Regulations

If a delivery includes such technology and / or supply that is subject to the export regulations, the Seller shall obtain due permissions, approvals, license etc.

20. Cancellation / Termination of Contract and Risk Purchase

20.1 Purchaser shall have the right to completely or partially terminate the agreement by means of written notice to that effect without prejudicing its other rights, in the event that:

- the Seller defaults on one or more of the obligations as contained in the agreement;
- the Seller is declared bankrupt, its business has been shut down or liquidated, a substantial part of its assets have been attached/destroyed, or the business has been transferred to a third party;
- any misrepresentation or hiding of material fact if detected at a later stage;
- the delivery is rejected after inspection or re-inspection.

In the event of termination the risk of the items already delivered but not of use to Purchaser, as determined by Purchaser, remains with the Seller. The items shall then be at the Seller's disposal and they are to be collected by the Seller. The Seller shall refund any payments made by Purchaser in terms of the terminated agreement immediately, not later than 30 days.

20.2 In the event of termination due to reasons or defaults by the Seller, the Purchaser may at his option procure such items and in such manner as he deems appropriate, goods not delivered or others of similar description where goods exactly complying with particular are not, in the opinion of the Purchaser, which shall be final, readily procurable, at the risk and cost of the Seller and the Seller shall be liable to the Purchaser for any excess cost. The cost of purchases made by the Purchaser at the risk and cost of the Seller shall be worked out by BHEL after loading handling charges procured from alternate source/s. The Seller shall on no account be entitled to any gain on such repurchases by the Purchaser.



21. Force Majeure

The supplier shall not be considered in default if delay occurs due to causes beyond their control such as Acts of God, Natural Calamities, Fire, Frost, Flood, Civil War, Civil Commotion, Riot, Government Restrictions.

Only those causes that have duration of more than seven days shall be considered cause of force majeure. Notification to this effect duly certified by local chamber of commerce / statutory authorities with supporting documents shall be given by the supplier to BHEL by registered letter/courier service immediately without loss of time.

In the event of delay due to such causes the delivery schedule shall be extended for a length of time equal to the period of Force Majeure or at the option of BHEL the order may be cancelled. Such cancellation would be without any liability whatsoever on the part of BHEL.

In the event of such cancellation the supplier shall refund any amount advanced or paid to the supplier by BHEL and deliver back any material issued to him by BHEL and release facilities, if any, provided by BHEL.

22. Non-waiver of Defaults

If any individual provision of the Contract is invalid, the other provisions shall not be affected.

23. Settlement of Disputes

23.1 Except as otherwise specifically provided in the Contract, all disputes concerning questions of the facts arising under the Contract, shall be decided by the Purchaser, subject to written appeal by the Seller to the Purchaser, whose decision shall be final.

23.2 Any disputes or differences shall to the extent possible be settled amicably between the parties thereto, failing which the disputed issues shall be settled through arbitration.

23.3 The Seller shall continue to perform the contract, pending settlement of dispute(s).

24. Arbitration

All disputes arising in connection with the contract shall be settled by mutual consultation. If no agreement is reached the dispute shall be settled in accordance with the provisions of the Arbitration and Conciliation Act, 1996 and the rules made there under. The dispute shall be referred for arbitration to any arbitrator to be appointed by the Head of the Unit, BHEL-Hyderabad. The award of the arbitrator shall be final and binding on both the Parties. The venue of the Arbitration shall be Hyderabad in India. The Award given by the Arbitrator shall be a speaking award and in English language. All questions, disputes, differences arising under, out of or in connection with this contract shall be exclusive jurisdiction of Sangareddy/Hyderabad Courts, Andhra Pradesh.

25. Applicable Laws and Jurisdiction of Courts

This agreement shall be construed and interpreted in accordance with the laws of India and shall have exclusive jurisdiction of Sangareddy/Hyderabad Courts, Andhra Pradesh, India.

Terms & Conditions of Reverse Auction

Against this enquiry for the subject item/ system with detailed scope of supply as per enquiry specifications, BHEL may resort to “REVERSE AUCTION PROCEDURE” i.e., ON LINE BIDDING (THROUGH A SERVICE PROVIDER). The philosophy followed for reverse auction shall be English Reverse (No ties).

1. For the proposed reverse auction, technically and commercially acceptable bidders only shall be eligible to participate.
2. Those bidders who have given their acceptance for Reverse Auction (quoted against this tender enquiry) will have to necessarily submit ‘online sealed bid’ in the Reverse Auction. Non-submission of ‘online sealed bid’ by the bidder for any of the eligible items for which techno-commercially qualified, will be considered as tampering of the tender process and will invite action by BHEL as per extant guidelines in vogue.
3. BHEL will engage the services of a service provider who will provide all necessary training and assistance before commencement of on line bidding on internet.
4. In case of reverse auction, BHEL will inform the bidders the details of Service Provider to enable them to contact & get trained.
5. Business rules like event date, time, bid decrement, extension etc. also will be communicated through service provider for compliance.
6. Bidders have to fax the Compliance form (annexure IV) before start of Reverse auction. Without this, the bidder will not be eligible to participate in the event.
7. In line with the NIT terms, BHEL will provide the calculation sheet (e.g., EXCEL sheet) which will help to arrive at “Total Cost to BHEL” like Packing & forwarding charges, Taxes and Duties, Freight charges, Insurance, Service Tax for Services and loading factors (for non-compliance to BHEL standard Commercial terms & conditions) for each of the bidder to enable them to fill-in the price and keep it ready for keying in during the Auction.
8. Reverse auction will be conducted on scheduled date & time.
9. At the end of Reverse Auction event, the lowest bidder value will be known on auction portal.

10. The lowest bidder has to fax/e-mail the duly signed and filled-in prescribed format for price breakup including that of line items, if required, (Annexure VII) as provided on case-to-case basis to Service provider within two working days of Auction without fail.
11. In case BHEL decides not to go for Reverse Auction procedure for this tender enquiry, the Price bids and price impacts, if any, already submitted and available with BHEL shall be opened as per BHEL's standard practice.
12. Bidders shall be required to read the "Terms and Conditions" section of the auctions site of Service provider, using the Login IDs and passwords given to them by the service provider before reverse auction event. Bidders should acquaint themselves of the 'Business Rules of Reverse Auction', which will be communicated before the Reverse Auction.
13. If the Bidder or any of his representatives are found to be involved in Price manipulation/ cartel formation of any kind, directly or indirectly by communicating with other bidders, action *as per extant BHEL guidelines*, shall be initiated by BHEL and the results of the RA scrapped/ aborted.
14. The Bidder shall not divulge either his Bids or any other exclusive details of BHEL to any other party.
15. In case BHEL decides to go for reverse auction, the H1 bidder(s) (whose quote is highest in online sealed bid) may not be allowed to participate in further RA process.

Business Rules for Reverse Auction

This has reference to tender no **{tender number....date...}**. BHEL shall finalise the Rates for the supply of **{item name}** through Reverse Auction mode. BHEL has made arrangement with M/s. **{Service provider}**, who shall be BHEL's authorized service provider for the same. Bidders should please go through the guidelines given below and submit acceptance of the same. The technical & commercial terms are as per (a) BHEL Tender Enq. No. {...} dated {...}, (b) Bidders' technical & commercial bid (in case of two part bid) and (c) subsequent correspondences between BHEL and the bidders, if any.

1. Schedule for reverse auction: The Reverse Auction is tentatively scheduled on **{date}**:

- **Online Sealed Bid:-**

- **{Start Time:**
- **Close Time: }**

- **Online Reverse Auction:-**

- **{Start Time:**
- **Close Time:}**

2. Auction extension time: If a bidder places a bid in the last {...} minutes of closing of the Reverse Auction and if that bid gets accepted, then the auction's duration shall get extended automatically for another {...} minutes, for the entire auction (i.e. for all the items in the auction), from the time that bid comes in. Please note that the auto-extension will take place only if a bid comes in those last {...} minutes and if that bid gets accepted as the lowest bid. If the bid does not get accepted as the lowest bid, the auto-extension will not take place even if that bid might have come in the last {...} minutes. In case, there is no bid in the last {...} minutes of closing of Reverse Auction, the auction shall get closed automatically without any extension. However, bidders are advised not to wait till the last minute or last few seconds to enter their bid during the auto-extension period to avoid complications related with internet connectivity, network problems, system crash down, power failure, etc.

The above process will continue till completion of Reverse Auction.

Complaints/ Grievances, if any, regarding denial of service or any related issue should be given in writing thru e-mail/ fax to M/s. **{Service provider}** with a copy to BHEL within 15 minutes from the initial closing time of Online Reverse Auction.

3. Bid price: The Bidder has to quote the F.O.R. destination Price inclusive of Packing & Forwarding charges, all the routine & type tests as per tender scope, ED + cess, CST against C-form, Freight (bidder to provide original Freight paid receipt), insurance charges, etc. including loading (if indicated by BHEL due to deviations in commercial terms) for the Items specified. Details are as shown in Excel Sheet for calculation of Landed cost.

Note: For the consideration of L1 bidder, the bid value shall be reduced by loading amount, if applicable.

- 4. Bidding currency and unit of measurement:** Bidding will be conducted in *{Indian Rupees per Unit}* of the material as per the specifications *{...}*

In case of foreign currency bids, exchange rate (TT selling rate of State Bank of India) as on scheduled date of tender opening (Part-I bid in case of two part bid) shall be considered for conversion in Indian Rupees.

- 5. Validity of bids:** Price shall be valid for *{... days}* from the date of reverse auction. These shall not be subjected to any change whatsoever.
- 6. Lowest bid of a bidder:** In case the bidder submits more than one bid, the lowest bid at the end of Online Reverse Auction will be considered as the bidder's final offer to execute the work.
- 7. Post auction procedure:** BHEL will proceed with the Lowest Bid in the Reverse Auction for further processing.

8. Procedure of Reverse Auctioning

- i. **Online Sealed Bid:** This duration of online sealed bid will be *{...}* minutes. All bidders to submit their online sealed bids during this period.
 - ii. **Online Reverse Auction:** The 'opening price' i.e. start price for RA and 'bid decrement' will be decided by BHEL.
 - iii. If BHEL decides the lowest online sealed bid as the starting price, then the lowest bidder in online sealed bid shall be shown as current L1 automatically by the system and no acceptance of that price is required. System shall have the provision to indicate this bid as current L1.
 - iv. Bidders by offering a minimum bid decrement or the multiples thereof can displace a standing lowest bid and become "L1" and this continues as an iterative process.
 - v. After the completion of the online reverse auction, the Closing Price (CP) shall be available for further processing.
- 9.** If no bid is received in the auction system/ website within the specified time duration of the online RA, then BHEL will scrap the online reverse auction process and proceed with the conventional mode of tendering (opening of the envelope sealed bids earlier submitted by the bidders).

In cases where no bidder accepts the start price, the RA may be treated as failed and sealed envelope price bids of all the techno-commercially qualified bidders shall be opened and the tender processed accordingly. Wherever the techno-commercially acceptable bidder(s) had agreed to participate in the RA and had failed to submit the online sealed bid, the envelope sealed bids of such bidder(s) shall not be entertained.

Wherever, the evaluation is done for individual items of the package, and no bid is received for some of the item(s), RA will be considered as failed for these item(s), re-reverse auction/ retendering will be conducted for these items.

10. Only those bidders who have submitted the 'online sealed bid' within the scheduled time shall be eligible to participate further in RA process. However, the H1 bidder(s) (whose quote is highest in online sealed bid) may not be allowed to participate in further RA process.
11. Any commercial/ technical loading shall be intimated to bidders prior to RA. The excel sheet provided in this regard shall cover all these aspects. Commercial/ technical loading if any, shall be added by the respective bidder in its price during online sealed bid & Online Reverse Auction. Modalities of loading & de-loading shall be separately intimated to the bidders.
12. Computerized reverse auction shall be conducted by BHEL (through M/s {*Service Provider*}), on pre-specified date, while the bidders shall be quoting from their own offices/ place of their choice. Internet connectivity shall have to be ensured by bidders themselves.

During the RA if a bidder is not able to bid and requests for extension of time by fax/ e-mail/ phone then time extension of additional 15 minutes will be given by the service provider provided such requests come before 5 minutes of auction closing time. However, only one such request per bidder can be entertained.

Despite this extension if bidder fails to upload his prices due to extreme case of failure of Internet connectivity, (due to any reason whatsoever may be) it is the bidders' responsibility/ decision to send fax communication immediately to M/s. {*Service provider*}, furnishing the price the bidder wants to bid online with a request to the service provider to upload the faxed price on line so that the service provider will upload that price on line on behalf of the Bidder. It shall be noted clearly that the concerned bidder communicating this price to service provider has to solely ensure that the fax message is received by the service provider in a readable/ legible form and also the Bidder should simultaneously check up with service provider about the clear receipt of the price faxed. It shall also be

clearly understood that the bidder shall be at liberty to send such fax communications of prices to be up loaded by the service provider only within the closure of Bid time and under no circumstance it shall be allowed beyond the closure of Bid time /reverse auction. It shall also be noted that the service provider should be given a reasonable required time by the bidders, to upload such prices online and if such required time is not available at the disposal of the Service provider at the time of receipt of the fax message from the bidders, the service provider will not be uploading the prices and either BHEL or the service provider are not responsible for this unforeseen circumstances. In order to ward-off such contingent situation bidders are requested to make all the necessary arrangements/ alternatives whatever required so that they are able to circumvent such situation and still be able to participate in the reverse auction successfully. Failure of power or loss of connectivity at the premises of bidders during the Reverse auction cannot be the cause for not participating in the reverse auction. On account of this, the time for the auction cannot be extended and neither BHEL nor M/s. {Service provider} is responsible for such eventualities.

13. Proxy bids: Proxy bidding feature is a pro-bidder feature to safe guard the bidder's interest of any internet failure or to avoid last minute rush. The proxy feature allows bidders to place an automated bid in the system directly in an auction and bid without having to enter a new amount each time a competing bidder submits a new offer. The bid amount that a bidder enters is the minimum that the bidder is willing to offer. Here the software bids on behalf of the bidder. This obviates the need for the bidder participating in the bidding process until the proxy bid amount is decrementally reached by other bidders. When proxy bid amount is reached, the bidder (who has submitted the proxy bid) has an option to start participating in the bidding process.

The proxy amount is the minimum amount that the bidder is willing to offer. During the course of bidding, the bidder cannot delete or change the amount of a proxy bid.

Bids are submitted in decrements (decreasing bid amounts). The application automates proxy bidding by processing proxy bids automatically, according to the decrement that the auction originator originally established when creating the auction, submitting offers to the next bid decrement each time a competing bidder bids, regardless of the fact whether the competing bids are submitted as proxy or standard bids. However, it may please be noted that if a manual bid and proxy bid are submitted at the same instant manual bid will be recognized as the L1 at that instant.

In case of more than one proxy bid, the system shall bid till it crosses the threshold value of 'each lowest proxy bid' and thereafter allow the competition to decide the final L1 price.

Proxy bids are fed into the system directly by the respective bidders. As such this information is privy only to the respective bidder(s).

14. Bidders are advised to get fully trained and clear all their doubts such as refreshing of Screen, quantity being auctioned, tender value being auctioned etc.
15. M/s. {*Service provider*}, shall arrange to demonstrate/ train the bidder or bidder's nominated person(s), without any cost to bidders. M/s. {*Service provider*}, shall also explain the bidders, all the rules related to the Reverse Auction/ Business Rules Document to be adopted along with bid manual. Bidders are required to give their compliance on it before start of bid process.
16. Successful bidder shall be required to submit the final prices, quoted during the Online Reverse Auction in Annexure - VII after the completion of auction to M/s. *Service provider* besides BHEL, duly signed and stamped as token of acceptance without any new condition other than those already agreed to before start of auction.
17. Any variation between the final bid value and that in the confirmatory signed price breakup document will be considered as tampering the tender process and will invite action by BHEL as per extant guidelines in vogue.
18. Bidders' bid will be taken as an offer to execute the work/ supplies the item as per enquiry no. {...} dt. {...}. Bids once made by the bidder, cannot be cancelled/ withdrawn and bidder shall be bound to execute the work as mentioned above at bidder's final bid price. Should bidder back out and not execute the contract as per the rates quoted, BHEL shall take action as per extant guidelines in vogue.
19. Bidders shall be assigned a **Unique User Name & Password** by BHEL or M/s. {*Service provider*}. Bidders are advised to change the Password and edit the information in the Registration Page after the receipt of initial Password from BHEL/ M/s. {*Service provider*} to ensure confidentiality. All bids made from the Login ID given to the bidders will be deemed to have been made by the bidders/ bidders' company.
20. Bidders shall be able to view the following on their screen along with the necessary fields during Online Reverse Auction:

- a. Leading (Running Lowest) Bid in the Auction (only total price of package)
 - b. Bid Placed by the bidder
 - c. Start Price
 - d. Decrement value
- 21.** After receipt of the system report from the Service Provider after completion of the Online Reverse Auction, BHEL will decide upon the winner. BHEL's decision on award of contract shall be final and binding on all the Bidders.
- 22.** BHEL reserves the right to cancel the Reverse Auction process/ tender at any time, before ordering, without assigning any reason.
- 23.** BHEL shall not have any liability to bidders for any interruption or delay in access to the site irrespective of the cause. In such cases, the decision of BHEL shall be binding on the bidders.
- 24.** Other terms and conditions shall be as per bidder's techno-commercial offers and other correspondences, if any, till date.
- 25.** Bidders are required to submit their acceptance to the terms/ conditions/ modalities before participating in the Reverse Auction in the process compliance Form as per Annexure-IV.
- 26.** BHEL can decide to extend, reschedule or cancel any Auction with prior intimation to all bidders.
- 27.** If there is any clash between this business document and the FAQ available, if any, in the web site of M/s. {*Service provider*} the terms & conditions given in this business document will supercede the information contained in the FAQs. Any changes made by BHEL/ service provider (due to unforeseen contingencies) after the first posting shall be deemed to have been accepted if the bidder continues to access the portal after that time.

Mandate to Service Provider

Ref :

Date :

To,
M/s. {Service provider}

Sub: Providing of Services for Reverse Auction.

Ref: No {...} date {...}

Dear Sirs,

Please conduct Reverse Auction as per the following details:

- **Scope:** Auction event management with training of BHEL and its bidders.
- Price: Rs. {.....}/- . No other duties, Taxes, levies etc. except service tax @ {.....}% shall be payable for conducting reverse auction. This price is firm.
- Payment Terms: 100% payment after successful completion of Auction.
- Completion of Auction: The auction shall be deemed to have been successfully completed on receipt and acceptance of final report including hard copy of the final bid with price break up including that of line items, if any, duly signed by the successful bidder who has participated in the reverse auction. The bill shall be submitted along with the completion report to the undersigned.
- The General Terms & Conditions and customized Business Rules of the Reverse Auction are as per Annexure – I & II.
- The list of bidders with their contact details is given in Annexure - V and the details of the item (s) to be Reverse Auctioned are as per Annexure - VI.
- Please acknowledge receipt of this letter order and also confirm that final report (duly signed and stamped by M/s. {Service provider}) including hard copy of the final bid with breakup of prices including that of line items duly signed by the successful bidder (duly endorsed by M/s. {Service provider}) shall be submitted within **four** working days of conclusion of auction.

Yours sincerely,

(for and on behalf of BHEL)

Note:

- i) The case of rescheduled auction event will be considered separate event for the purpose of payment.
- ii) If the event has been conducted as per mandate, you shall be paid irrespective of RA outcome.

Buyer Name	<ul style="list-style-type: none"> - <i>Name of BHEL Unit</i> - <i>Full postal address</i> - <i>Fax:</i> - <i>Phone:</i> - <i>Email:</i> - <i>Contact person name:</i> - <i>Phone:</i> -
Auction to be conducted by	<ul style="list-style-type: none"> - <i>Name of Service provider</i> - <i>Full postal address</i> - <i>Fax:</i> - <i>Phone:</i> - <i>Email:</i> - <i>Contact person name:</i> - <i>Phone:</i> -
Date of Auction	<ul style="list-style-type: none"> - <i>Date of Auction</i> - <i>Online sealed bid auction time:</i> - <i>Online reverse auction time:</i> - <i>Online auction website:</i> -
Documents Attached: (To be sent to the bidders)	<ol style="list-style-type: none"> 1) Terms & Conditions of Reverse Auction (<u><i>Annexure-I</i></u>) 2) Business rules for Reverse Auction (<u><i>Annexure-II</i></u>) 3) Process Compliance Form (<u><i>Annexure-IV</i></u>) 4) Details of item (s) to be Reverse Auctioned (<u><i>Annexure-VI</i></u>) 5) Post RA Price confirmation by bidder (<u><i>Annexure-VII</i></u>)

Process Compliance Form

(The bidders are required to print this on their company's letterhead and sign, stamp before faxing)

To

- M/s. {Service provider
- Postal address}

Sub: Agreement to the Process related Terms and Conditions

Dear Sir,

This has reference to the Terms & Conditions for the Reverse Auction mentioned in the RFQ document for {Items} against BHEL enquiry/ RFQ no.{.....} dt. {.....}

This letter is to confirm that:

- 1) The undersigned is authorized official/ representative of the company to participate in RA and to sign the related documents.
- 2) We have studied the Reverse Auction Terms & Conditions and the Business rules governing the Reverse Auction as mentioned in your letter and confirm our agreement to them.
- 3) We also confirm that we have taken the training on the auction tool and have understood the functionality of the same thoroughly.
- 4) We also confirm that, in case we become L1 bidder, we will email/ fax the price confirmation & break up of our quoted price (including that of line items) as per Annexure - VII within **two** working days (of BHEL) after completion of RA event, besides sending the same by registered post/ courier both to M/s. BHEL and M/s. {Service provider.}

We, hereby confirm that we will honor the Bids placed by us during the auction process.

With regards

Signature with company seal

Name –

Company / Organization

Designation within Company / Organization

Address of Company / Organization

- Sign this document and Fax it to M/s {Service provider} at {.....} prior to start of the Event.
- Attach a signed copy of the RFQ document along with the Agreement Form/ Process Compliance form and send to M/s. {Service provider}

List of bidders and their address/ contact person details

Sl. No.	Address	Contact Person
1	- <i>Name of bidder</i> - <i>Full postal address</i> - <i>Fax:</i> - <i>Phone:</i> - <i>Email:</i> -	- <i>Contact person name:</i> - <i>Phone:</i> - <i>Email:</i> -
2		
3		
..		
..		

Details of item (s) to be Reverse Auctioned

1. {Details of items including quantity, specification, Enquiry no. & date

- 1.
- 2.
- ..
- ..
- ..
- ..
- }

The offers of all the bidders are technically & commercially frozen as submitted by the bidders and clarified in subsequent correspondence, if any, with the bidders.

RA price confirmation and breakup

To

- **M/s. Service provider**
- *Postal address*

CC: M/s BHEL

*{Unit-
Address-}*

Sub: **Final price quoted during Reverse Auction and price breakup**

Dear Sir,

We confirm that we have quoted.

Rs.{_____} for item covered under tender enquiry No. {...} dt.{...}

Total price of the items covered under above cited enquiries is inclusive of *{Packing & forwarding, E.D., C.S.T., freight and insurance charges upto {.....} District,{.....} State and Type Test Charges etc., (exclusive of service tax), other as per NIT}*

as our final landed prices as quoted during the Reverse Auction conducted today *{date}* which will be valid for a period of {_____} days.

The price break-up including that of line items is as given below.

Total - =====
Rs.
=====

Thanking you and looking forward to the valuable order from BHEL.

Yours sincerely,

For _____

Name:
Company:
Date:
Seal: