

24 Nos. M16x30 taps

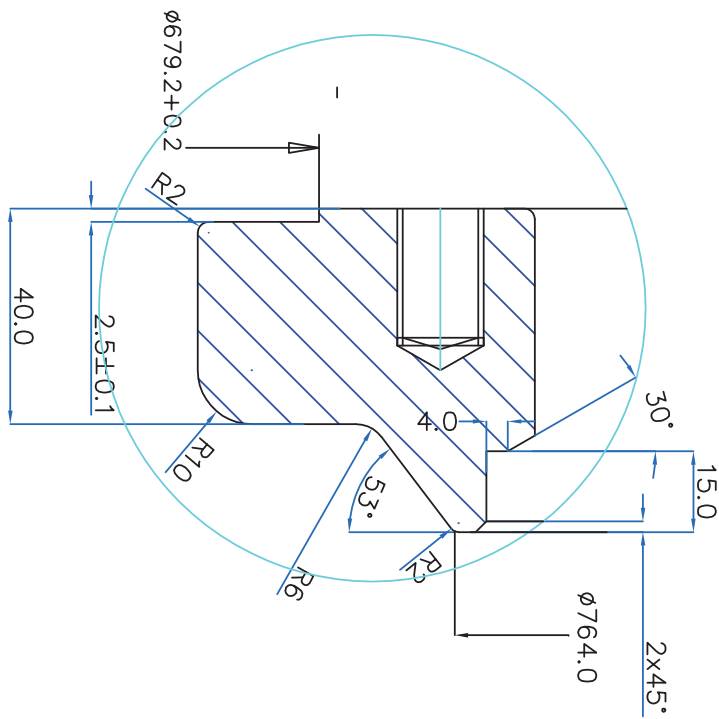

VAR. NO.	REMARKS	VAR. ITEM NO.	DESCRIPTION	PLT	DRAWING NO.	T/NO.	MATL. CODE	A	UNIT WT.	C	QTY.	ZONE
01			PLATE		750 x 70		SS-304L		01			

CGSM-145

DEPT.	GRADE OF	DRN	NAME	SIGN.	DATE	NO. OF
HYDERABAD	HYDERABAD	ESMURTHY	ESMURTHY		08.07.14	01
APPD	MMRAO	MMRAO	MMRAO		08.07.14	01

REV. DATE	ALTERED	REV. DATE	ALTERED
ZONE	CHECKED	ZONE	CHECKED

TITLE	CAD CODE	DRAWING NO.	SHEET NO.
TOP/BOTTOM FLANGE		RD DG 4 35 1351 1402	NO. OF SHEETS

10/07/14