

THE INFORMATION ON THIS DOCUMENT IS THE PROPERTY OF BHARAT HEAVY ELECTRICALS LIMITED. IT MUST NOT BE USED DIRECTLY OR INDIRECTLY IN ANY WAY DETERIMENTAL TO THE INTEREST OF THE COMPANY.

1002A-23131-3

DRAWING No.

FIRST ANGLE PROJECTION

(ALL DIMENSIONS ARE IN mm)

FORM DG 38(B)

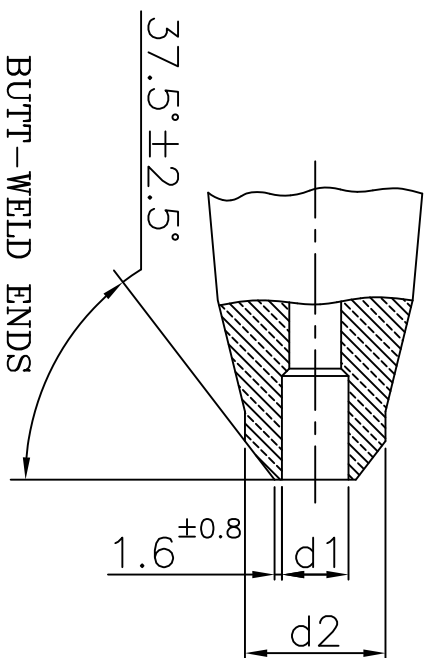
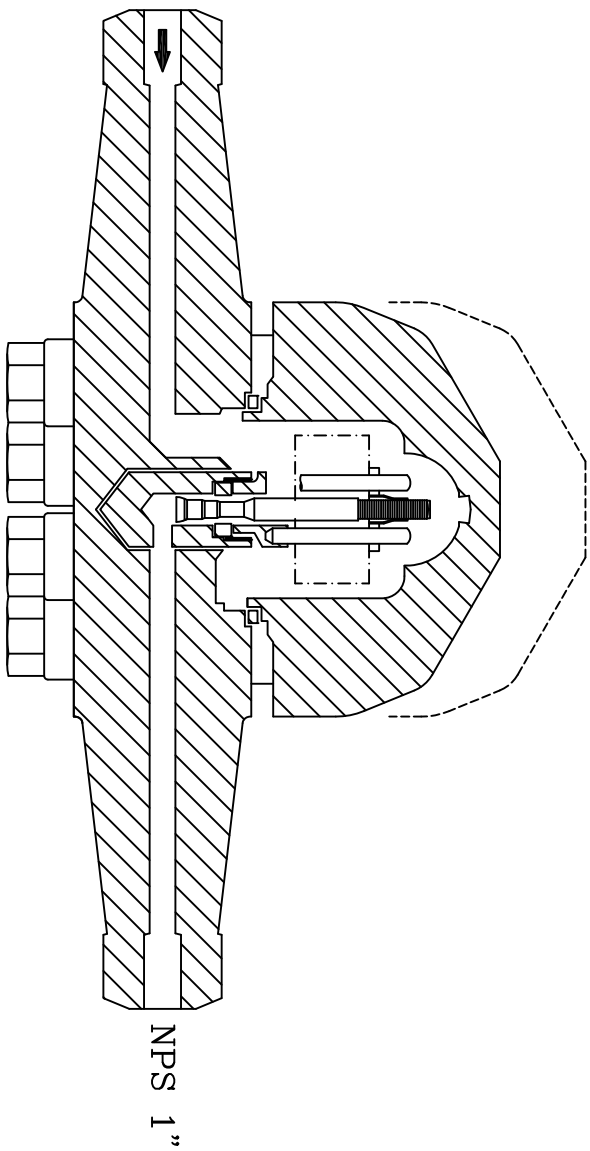

DESIGN DATA AND PIPE CONNECTION LIST FOR STEAM TRAP (THERMOSTATIC BIMETALLIC TYPE):-

TAG NO OF STEAM TRAP	VAR 01
	MAL23AA041
	MAL24AA041
MATERIAL OF STEAM TRAP	ASTM A 182 F91
MAX. INLET PR. (g)	67bar
MAX. INLET/OUTLET TEMP.	601°C
d1	24.3 mm
d2	33.4 mm
HYDROSTATIC TEST PR.(bar)	101(min.)
TYPE OF END CONNECTION	BUTT WELD

OUTLET PRESSURE IS ATMOSPHERIC PRESSURE.

NOTE:- THIS DRAWING SHALL BE READ WITH DOC. NO. 413137U8401.

Inventory No.	Sign & Date	Ref.Drawing No.
---------------	-------------	-----------------

GMS No./C B O M	AGREED	NAME	SIGN	DATE
	DEPT			
GRADE OF UNTOL.DIM	M/CG.-d/M/f	AA0230208		
	WELDING-A/B/d/d	AA0621104		
REV	DATE	ALTERED	CHECKED	
GAS CUTTING-T3'AA0621101				

TYPE OF PRODUCT		OR		STATUS OF DRG	
NAME OF CUSTOMER/PROJECT					
BHARAT HEAVY ELECTRICALS LTD. RANIPUR, HARDWAR					
DEPT	STE	SCALE	WEIGHT (KG)	DRN	NAME
CODE	4011	N.T.S.	-	P.S.SHARMA	SIGN
TITLE :			REF. TO ASSY. DRG.	DATE	NO. OF
STEAM TRAP			--	23.09.15	VAR
THERMOSTATIC (BIMETALLIC TYPE)				23.09.15	
CARD	CODE	DRAWING NO.	REV.	NO. OF	NO. OF
		3-13137-V2001	00	22	23
			01	22	24
				22	23
				24	24

SIZE A3