

FIRST ANGLE PROJECTION

ALL DIMENSIONS ARE IN mm.

REV.	DATE	ALTERED	REV.	DATE	ALTERED	REV.	DATE	ALTERED
		CHECKED			CHECKED			CHECKED
		APPROVED			APPROVED			APPROVED

Sintered NdFeB Magnet

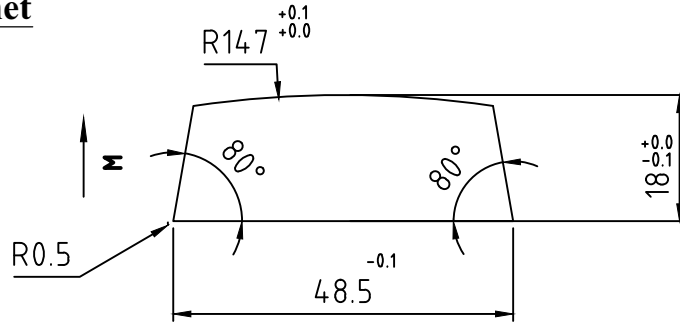

Length = 50^{+0.0}/_{-0.1} mm

Technical details for NdFeB Magnets (N35AH grade)

Quantity - 70 Nos.

1. Br = 11.7 to 12.1 kG.
2. Hc = 10.8 to 11.6 kOe.
3. Hci = ≥ 33.0 kOe.
4. BHmax = 33-35 MGOe
5. Temperature grade = ≥ 230°C.
6. Temperature coefficient of Br = -0.11 to -0.12 % / deg C.
7. Nickel Coating to be provided, to prevent corrosion of magnet.
8. Magnetization/orientation along 18 mm thick direction.
9. Magnets to be supplied in magnetized condition. 34 Magnets to be magnetized in N-S direction & 34 Magnets in S-N direction. Two (02 no.s) Magnets are to be supplied in un-magnetized condition taken from the different manufacturing lots.
10. Original Test certificate from the manufacturer showing magnet specifications and grade is to be furnished at the time of supply.
11. Warranty/Guarantee certificate for one year should be provided by the supplier.
12. All corners are to be rounded off. (R 0.5 mm).

THE INFORMATION ON THIS DOCUMENT IS THE PROPERTY OF BHARAT HEAVY ELECTRICALS LIMITED. IT MUST NOT BE USED DIRECTLY OR INDIRECTLY IN ANY WAY DETRIMENTAL TO THE INTEREST OF THE COMPANY.

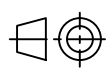
COMPUTER NO.					
REF. DRG. NO.	DESCRIPTION & DRG.NO.	VAR NO.	RAW MATERIAL SIZE OR CASTING DRG.NO. OR FORGING DRG.NO.	MATL. CODE	NET.WT. GROSS WT
				MATL. SPECN.	QTY.
SIGN. & DATE	TYPE OF PRODUCT OR NAME OF CUSTOMER/PROJECT		High Temperature NdFeB Magnets		
	 BHARAT HEAVY ELECTRICALS LIMITED Corp. R&D Division. Vikasnagar HYDERABAD - 500 093		DRN.	NAME	SIGN
INVENTORY NO.	DEPT. PMM		SCALE	DATE	NO.OF VAR.
	CODE 27		WEIGHT(K.G.)		
	TITLE		REF.TO ASSY.DRG.	ITEM NO.	
	NdFeB Magnet - 50		DRAWING NO. S 14 050 0001		REV. 00
			SHT.NO.	NO.OF SHT.	