

(~1.6)

(ALL DIMENSIONS ARE IN mm)

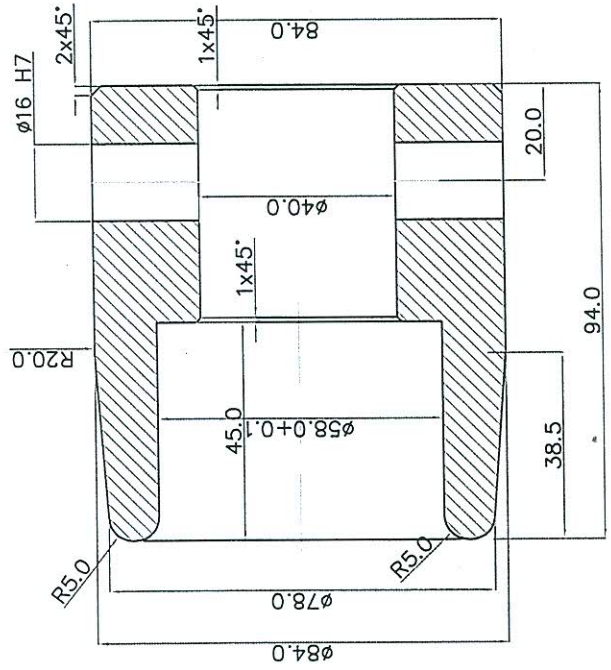

SECTION A-A

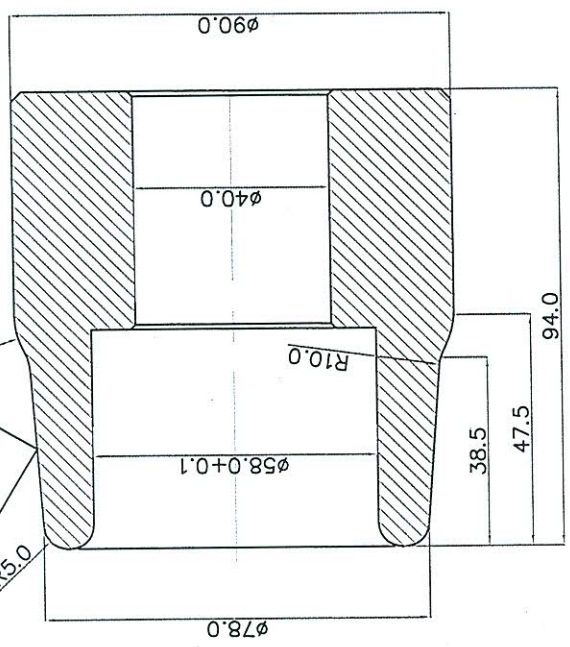
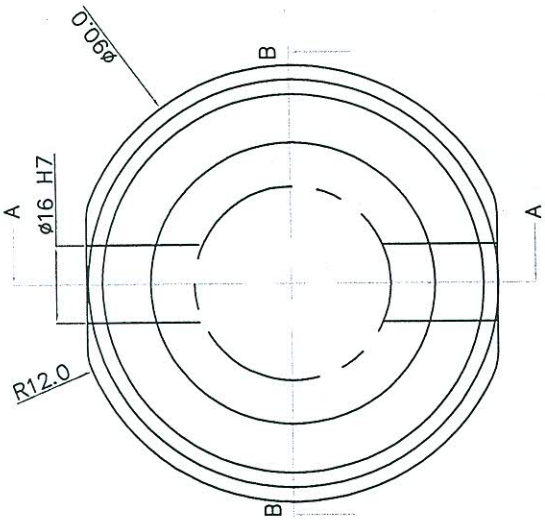

SECTION B-B

ALL SHARP EDGES SHALL BE MACHINED TO 0.5X45°
 PROFILED SURFACE SHALL BE FINE FINISHED TO RAO.8

GSM-400

| | | | | | | | | | |
|----------|---------|---------------|-------|--------------|---------|-----------|----------|------|------|
| VAR. NO. | REMARKS | VAR. ITEM NO. | BLOCK | DESCRIPTION | DR. NO. | AL. ALLOY | UNIT WT. | QTY. | ZONE |
| | | | 01 | φ100.0x110.0 | | | 01 | | |

| | | | | | | | | |
|-----------------|-------------------------------|-----------|--------------------------|---------------|------------|---------|------------|--------------|
| TYPE OF PRODUCT | NAME OF CUSTOMER | DEPT. | GRADE OF TOOL DIM. C/M/P | SCALE | WEIGHT(KG) | REF. TO | ITEM NO. | NO. OF ITEMS |
| | BHARAT HEAVY ELECTRICALS LTD. | | | NTS | | | | |
| NAME | DRN | CKD | APPS | HS/JAIN | DATE | SIGN. | NO. OF VAC | NO. OF ITEMS |
| KSRAD | MARAD | | | | 02.01.08 | | 01 | 01 |
| DRAWING NO. | | SHEET NO. | | NO. OF SHEETS | | | | |
| FD. DS. 4-35 | | 0617 | | 0230 | | | | |

| | | | | | | | |
|------|------|---------|---------|------|------|---------|---------|
| REV. | DATE | ALTERED | CHECKED | REV. | DATE | ALTERED | CHECKED |
| | | | | | | | |

INVENTORY NO.

SIGN. AND DATE

REF. DRG. NO.

THE INFORMATION ON THIS DOCUMENT IS THE PROPERTY OF BHARAT HEAVY ELECTRICALS LIMITED. IT MUST NOT BE USED DIRECTLY OR INDIRECTLY IN ANY WAY DETRIMENTAL TO THE INTEREST OF THE COMPANY.