

429.028

REVIZIYA NO	DATA DOKUMENTA	PROJEKTOVA ORGANIZATSIYA	PROJEKTOVA ORGANIZATSIYA	GRUPP NO. (KODIROVANIYA)
2-282			7234403	

NOTES:
 1. SURFACES MARKED V7 TO BE MANUFACTURED WITH IN A TOLERANCE OF ±0.1
 2. NON WORKING SHARP EDGES TO BE ROUNDED OFF R.1

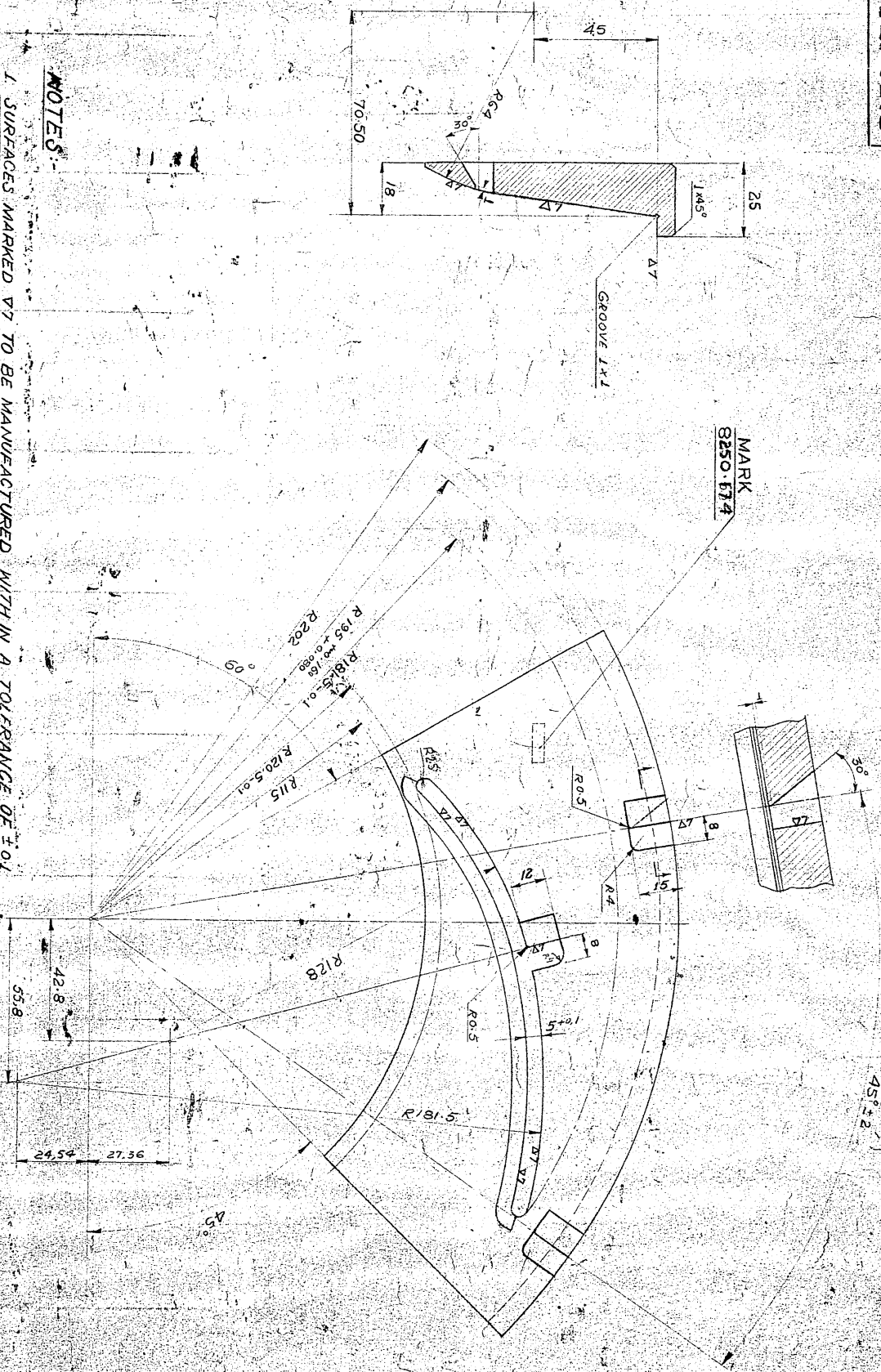

NO	DESIGNATION	DESCRIPTION	QTY	WEIGHT	MATERIAL
1	C100-90	MARKING TEMPLATE			R1846.0014
<p>MARKING TEMPLATE</p> <p>8250.674</p>					

45.2

THE REST V6

COPYRIGHT AND CONFIDENTIAL. THE INFORMATION ON THIS DOCUMENT IS THE PROPERTY OF BHARAT HEAVY ELECTRICALS LIMITED. IT MUST NOT BE USED DIRECTLY OR INDIRECTLY IN ANY MANNER TO THE INTEREST OF THE COMPANY.

1-11248 INVENTORY No. SIGN. & DATE REF. DRG. No.

DRAWING No. R8392-1402+1403

1.6 THE REST

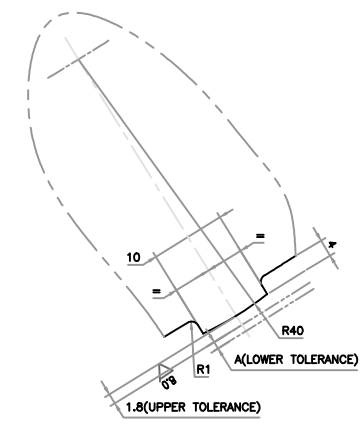
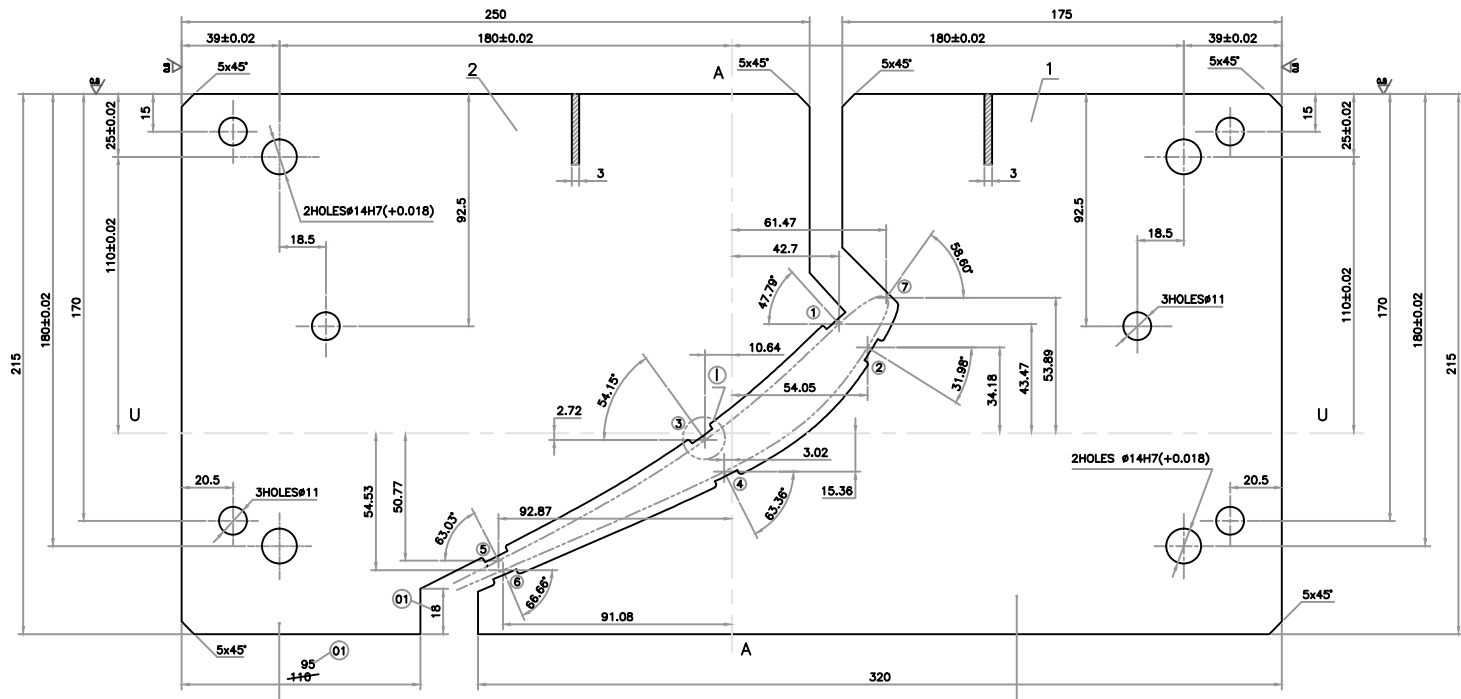

SCALE-NTS
DETAIL-'1' FOR ALL POINTS.

MARK
R8392-1403
SEC-A11-A11
INNER PROFILE
POINTS 1,3,5
FORM17.

MARK
R8392-1402
SEC-A11-A11
EXT. PROFILE
POINTS 2,4,6,7
FORM17

DRG. REDRAWN FROM ORIGINAL
DRN:-ASHOK 25-01-11
CHD:-RAVI 25-01-11
APD:-ANKUR 27-01-11

TECH.REQ:-

- *1:-THE MAXIMUM TOLERANCE TO BE MARKED ON BOTH THE SIDES.
- 2:-HARDEN TO HRc 50.55 AS PER PS-0912.008 (ONLY PROFILE).
- 3:-TO BE USED WITH WE Q-13-3400 (VERTICAL STAND).
- 4:-BLADE PROFILE AS PER DRG. NO.0-103-07-46023.
- 5:-MANUFACTURING ACCURACY OF PROFILE ±0.02.
- 6:-CONSERVATION TO BE DONE AS PER TL-30007.

ITEM NO.	PROFILE POINT	DIMENSION A	*MAX.TOLERANCE (1.8+)	W./ORDER NO.	DRG.NO.
01.	2	1.8	3.6	KBM-7407	R8392-1402
	4	1.8	3.6		
	6	1.8	3.6		
	7	0.5	2.3		
	1	0.5	2.3		
02.	3	0.5	2.3	KBM-7408	R8392-1403
	5	0.5	2.3		
	5	0.5	2.3		

02.	TEMPLATE INT.PROFILE	R8392-1403	T90M#W#2 A110892	01
01.	TEMPLATE EXT. PROFILE	R8392-1402	T90M#W#2 A110892	01

VAR.00	REMARKS	ITEM No.	DESCRIPTION	STD.	DRAWING No.	MATERIAL SPECN.	UNIT	UNIT WEIGHT	QTY.	ZONE

GMS No./Gr.SP.No.	STATUS OF DRG.	TYPE OF PRODUCT	COMP. DRG. No.	M/C TOOL TRANS No.	REF. DRG. No.
PEB YCG/B.DASS	08-10-03	250 MW (PANIPAT)	0-103-07-46003+6	2621	R8392-1257+1258

GRADE OF UNTOL.DIM. :-	M/CG-E/M/E/AA0230208	WELDING-A/B/C/D-AA0621104	GAS CUTTING-T3'AA0621101
------------------------	----------------------	---------------------------	--------------------------

REV.	DATE	ALTERED	SJTERS	DEPT.	JTE	SCALE	WEIGHT(Kg.)	REF. TO ASSY. DRG.	ITEM No.	No. OF ITEM
01	01	JTE-11-F008	25-01-11	209		1:1				

TITLE	DRN.	CHD	APD
TEMPLATE FOR PROFILE (INNER&OUTER) CHECKING SEC.(A11-A11)FORM-17	D.K.DOVAL	H.N.SHARMA	A.P.GARWAL

DRG. No.	SEC. No.	FORM No.
R8392-1402+1403	A11-A11	FORM-17

1470-4-964-0971
DRAWING NO. R8390-0964-0971

FIRST ANGLE PROJECTION (ALL DIMENSIONS ARE IN MM)

FORM DG44B

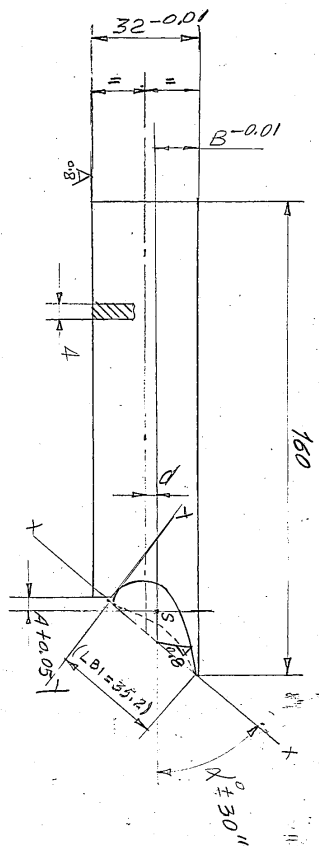

MARK
DRAWN
IX-32.00

SL. NO	VAR. NO	REMARKS	ITEM NO.	DESCRIPTION	STANDARD	DRAWING NO.	VAR. NO.	MATERIAL SPEC.	UNIT WEIGHT	DRAWING NO.
1	A+0.05	12.8	3.2	47.5°		R8390-0964				
2	B-0.01	13.2	2.8	49.5°		R8390-0965				
3	4	13.5	2.5	49.5°		R8390-0966				
4	3.8	13.9	2.1	50.5°		R8390-0967				
5	3.6	14.2	1.8	51.5°		R8390-0968				
6	3.3	14.6	1.4	52.5°		R8390-0969				
7	3.1	14.9	1.1	53.5°		R8390-0970				
8	2.9	15.2	0.8	54.5°		R8390-0971				

- NOTE:-
1. SHARP EDGES TO BE ROUNDED OFF.
 2. PROFILE CORRESPONDING TO DRG. NO. L-14600-35228 (SHEETS)
 3. PROFILE TO BE MATCHED PERFECTLY WITH THE CORRESPONDING SHADOW GRAPH WITH IN Q.2.
 4. HARDEN TO HRC 55-65 AS PER P.S. NO. D92008.
 5. CONSERVATION TO BE DONE AS PER T.E. DRAWING.

GRADE OF UNTOOL DIM
M/C G-C/M/T AA 0230208
WELDING -A/B/C/DAA0621104
GAS CUTTING -13 AA 0621101
REV DATE ALTERED
CHECKED

CARD TYPE 3 28
GMS NO./GR SP NO. 28
DATE 28
STATUS OF DRG 28

DEPT-77E
SCALE NTS
WEIGHT (KG) 0.175
CARD CODE
EXT. PROFILE IX-32.00-33.5

2-15602 INVENTORY NO.
18-8-98 SIGN & DATE

REF. DRG. NO.

COPYRIGHT AND CONFIDENTIAL THE INFORMATION ON THIS DOCUMENT IS THE PROPERTY OF BHARAT HEAVY ELECTRICALS LIMITED. IT MUST NOT BE USED DIRECTLY OR INDIRECTLY IN ANYWAY DETRIMENTAL TO THE INTEREST OF THE COMPANY

8 7 6 5 4 3 2 1

THE REST

3960-9560-0638R
SN 31M1WV1D

FIRST ANGLE PROJECTION (ALL DIMENSIONS IN mm.)

FORM DG 44(B)

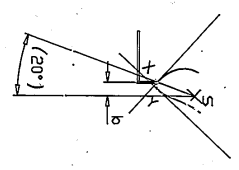
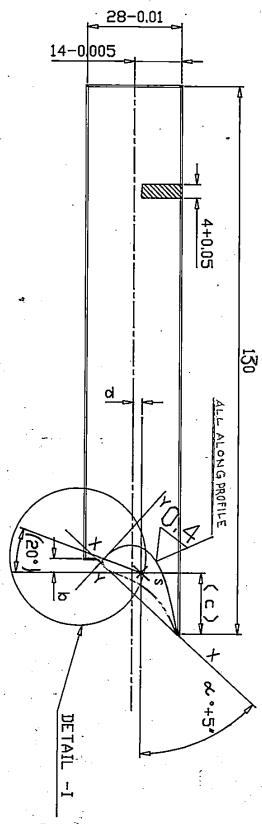

MARK
DRG. NO. R.....
TX-28j 4°.....

0.8/
THE REST

1. HARDEN TO HRC-55-60 AS PER P.S.NO. 0912008.
2. PROFILE TOLERANCE IS < 0.01.
3. PROFILE CORRESPONDS TO DRGND. 1-14600-35228.
4. PROFILE SHOULD PERFECTLY MATCH WITH CORRESPONDING SHADOWGRAPH WITHEN 0.02.
5. CONSERVATION TO BE DONE AS PER TL3000Z

SINO	α ± 5°	d	b	(C)	W/D NO.	DRAWING NO.
1.	47.5°	2.7	3.99	17.8	KBM-5071	R8390-0956
2.	48.5°	2.4	3.97	17.61	KBM-5072	R8390-0957
3.	49.5°	2.1	3.95	17.41	KBM-5073	R8390-0958
4.	50.5°	1.8	3.94	17.21	KBM-5074	R8390-0959
5.	51.5°	1.5	3.92	17.00	KBM-5075	R8390-0960
6.	52.5°	1.2	3.90	16.79	KBM-5076	R8390-0961
7.	53.5°	0.9	3.87	16.58	KBM-5077	R8390-0962
8.	54.5°	0.7	3.85	16.35	KBM-5078	R8390-0963

VAR.00	REMARKS	ITEM No.	DESCRIPTION	DRAWING No.	130mm6VCR-2 AA10821
CARD TYPE-3	28	28	28	28	28
GRADE OF UNTOL. DIM.	M/CG-C/M/F AA0230208	WELDING-A/B/C/D-AA0821104	GAS CUTTING-T3AA0821101	REV. DATE	ALTERED CHECKED
REV. DATE	ALTERED CHECKED	REV. DATE	ALTERED CHECKED	DEPT. JTE	SCALE
REV. DATE	ALTERED CHECKED	REV. DATE	ALTERED CHECKED	CODE 209	N.T.S.
REV. DATE	ALTERED CHECKED	REV. DATE	ALTERED CHECKED	WEIGHT(GG)	0.2 EACH
REV. DATE	ALTERED CHECKED	REV. DATE	ALTERED CHECKED	DRN. Y.D.D.	REF. TO ASSY. DRG. NO.
REV. DATE	ALTERED CHECKED	REV. DATE	ALTERED CHECKED	CHD RPT/HNS	REF. TO ASSY. DRG. NO.
REV. DATE	ALTERED CHECKED	REV. DATE	ALTERED CHECKED	APD A.P.A.	REF. TO ASSY. DRG. NO.
REV. DATE	ALTERED CHECKED	REV. DATE	ALTERED CHECKED	NAME	REF. TO ASSY. DRG. NO.
REV. DATE	ALTERED CHECKED	REV. DATE	ALTERED CHECKED	DATE	REF. TO ASSY. DRG. NO.
REV. DATE	ALTERED CHECKED	REV. DATE	ALTERED CHECKED	NO. OF	REF. TO ASSY. DRG. NO.
REV. DATE	ALTERED CHECKED	REV. DATE	ALTERED CHECKED	ITEM NO.	REF. TO ASSY. DRG. NO.
REV. DATE	ALTERED CHECKED	REV. DATE	ALTERED CHECKED	NO. OF	REF. TO ASSY. DRG. NO.
REV. DATE	ALTERED CHECKED	REV. DATE	ALTERED CHECKED	ITEM	REF. TO ASSY. DRG. NO.

VAR.00 REMARKS ITEM No. DESCRIPTION DRAWING No. 130mm6VCR-2 AA10821

CARD TYPE-3 28 28 28 28 28 28

GRADE OF UNTOL. DIM. M/CG-C/M/F AA0230208 WELDING-A/B/C/D-AA0821104 GAS CUTTING-T3AA0821101

REV. DATE ALTERED CHECKED REV. DATE ALTERED CHECKED REV. DATE ALTERED CHECKED

DEPT. JTE SCALE N.T.S. 0.2 EACH

CODE 209 WEIGHT(GG) 0.2 EACH

DRN. Y.D.D. REF. TO ASSY. DRG. NO. CHD RPT/HNS REF. TO ASSY. DRG. NO. APD A.P.A. REF. TO ASSY. DRG. NO. NAME REF. TO ASSY. DRG. NO. DATE REF. TO ASSY. DRG. NO. NO. OF REF. TO ASSY. DRG. NO. ITEM REF. TO ASSY. DRG. NO.

TITLE WORKING TEMPLATE FOR EXT. PROFILE TX-28

DRAWING NO. R8390-0956-0963 SHEET NO. 01 OF SHEET 01

SIZE A 2

COPYRIGHT AND CONFIDENTIAL
THE INFORMATION ON THIS DOCUMENT IS THE PROPERTY OF BHARAT
HEAVY ELECTRICALS LIMITED. IT MUST NOT BE USED DIRECTLY
OR INDIRECTLY IN ANY WAY DETRIMENTAL TO THE INTEREST OF COMPANY.

FIRST ANGLE PROJECTION

(ALL DIMENSIONS ARE IN mm)

FORM DG38(B)

DRAWING No. R8389-0763

6.3/
THE REST

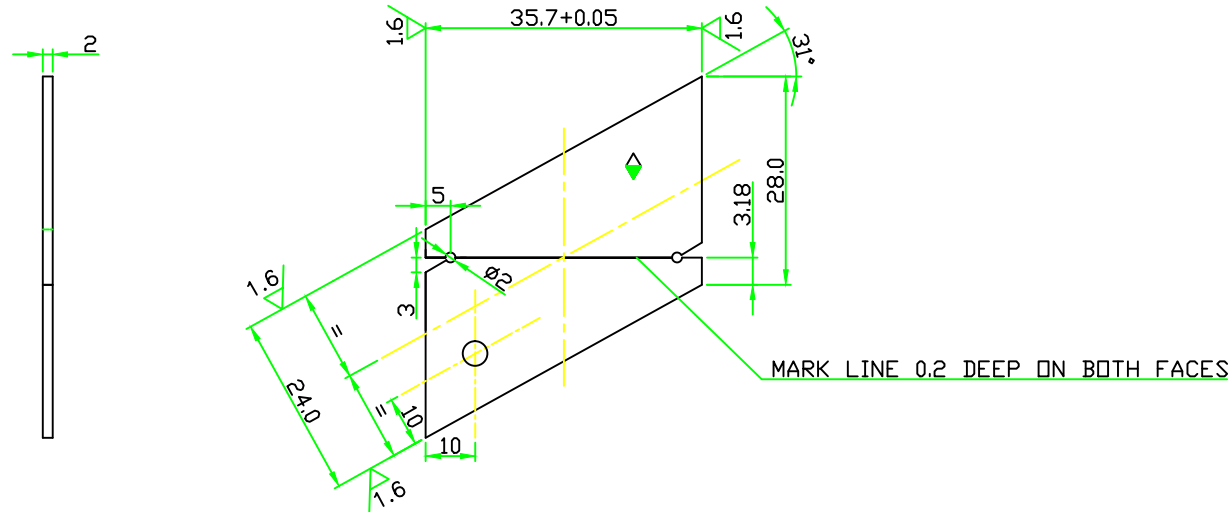

◇ MARK
R8389-0763

NOTES:-

- 1-MANUFACTURING ACCURACY ± 0.05 .
- 2-SHARP EDGES TO BE ROUNDED OFF.
- 3-CONSERVATION IS TO BE DONE AS PER TL 30007.
- *4-ALTERNATELY MATL AI5083,113H USED FOR DEFENCE PROJECT CAN BE USED WITH $t=5\text{mm}$.

VAR.00	REMARKS	ITEM No.	DESCRIPTION	STD	DRAWING No.	* X04Cr1Ni10Ti AA10740	A MATERIAL CODE	C MATERIAL SPECN.	UNIT	UNIT WEIGHT	QTY.
										1	

GMS No./GR.SP.No.	STATUS OF DRG	TYPE OF PRODUCT	COMP. DRG. No.	M/C TOOL TRANS No.	REF. DRG. No.
AGREED DEPT.	NAME	SIGN.	DATE	31010713021,01010113000	8R389-0693
TTX	SKUMAR	-Sd-	09.05.14	DESIGN ORDER No. ST/6052	M/C MODEL No. 934

GRADE OF UNTOL. DIM.:-	
M/CG- L /W/F	AA0230208
WELDING-A/B/C/D	AA0621104
GAS CUTTING-'T3'	AA0621101

	BHARAT HEAVY ELECTRICALS LTD. HARDWAR			DRN	NAME	SIGN.	DATE	No. OF VAR.
	CHD	RAVI	-Sd-	08.05.14				
	APD	ANKUR	-Sd-	10.05.14				

REV	DATE	ALTERED	REV	DATE	ALTERED	DEPT.	JTE	SCALE	WEIGHT(Kg)	REF.TO ASSY. DRG.	ITEM No. OF No. ITEMS
		CHECKED			CHECKED	209		N.T.S.	0.03		
						TITLE			DRAWING No.		REV
						MARKING&CHECKING TEMPLATE			R8389-0763		
						FOR INSERTION GROOVE STAGE NO.-17.			SHEET No. 01		No. OF SHEETS 01

SIZE A 3

COPYRIGHT AND CONFIDENTIAL
THE INFORMATION ON THIS DOCUMENT IS THE PROPERTY OF BHARAT
HEAVY ELECTRICALS LIMITED. IT MUST NOT BE USED DIRECTLY
OR INDIRECTLY IN ANY WAY DETRIMENTAL TO THE INTEREST OF COMPANY.

FIRST ANGLE PROJECTION

(ALL DIMENSIONS ARE IN mm)

FORM DG38(B)

DRAWING No. R8389-0762

6.3
✓ THE REST

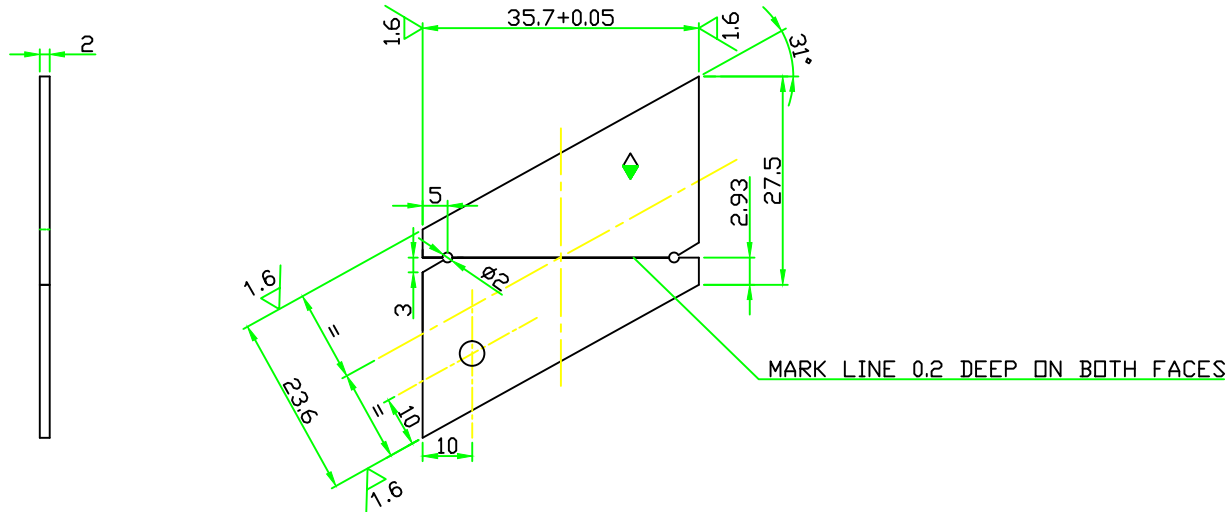

MARK
 R8389-0762

NOTES:-

- 1-MANUFACTURING ACCURACY ±0.05.
- 2-SHARP EDGES TO BE ROUNDED OFF.
- 3-CONSERVATION IS TO BE DONE AS PER TL 30007.
- *4-ALTERNATELY MATL AI5083,113H USED FOR DEFENCE PROJECT CAN BE USED WITH t=5mm.

VAR.00	REMARKS	ITEM No.	DESCRIPTION	STD	DRAWING No.	* X04Cr1Ni10Ti AA10740	A UNIT	UNIT WEIGHT	QTY.
								1	

GMS No./GR.SP.No.	STATUS OF DRG	TYPE OF PRODUCT	COMP. DRG. No.	M/C TOOL TRANS No.	REF. DRG. No.
AGREED DEPT.	NAME	SIGN.	DATE	DESIGN ORDER No.	M/C MODEL No.
TTX	SKUMAR	-Sd-	08.05.14	228MW ST/6051	934

GRADE OF UNTOL. DIM.:-	
M/CG- L /W/F	AA0230208
WELDING-A/B/C/D	AA0621104
GAS CUTTING-'T3'	AA0621101

	BHARAT HEAVY ELECTRICALS LTD. HARDWAR			No. OF VAR.
	DRN	NAME	SIGN.	DATE
	CHD	MUKESH	-Sd-	08.05.14
APD	RAVI	-Sd-	08.05.14	
	ANKUR	-Sd-	10.05.14	

REV	DATE	ALTERED	REV	DATE	ALTERED
		CHECKED			CHECKED

DEPT. JTE	SCALE	WEIGHT(Kg)	REF.TO ASSY. DRG.	ITEM No. OF
CODE 209	N.T.S.	0.03		No. ITEMS
TITLE			DRAWING No.	REV
MARKING&CHECKING TEMPLATE FOR INSERTION GROOVE STAGE NO.-16,18&19			R8389-0762	
			SHEET No. 01	No. OF SHEETS 01

SIZE A 3

COPYRIGHT AND CONFIDENTIAL
THE INFORMATION ON THIS DOCUMENT IS THE PROPERTY OF BHARAT
HEAVY ELECTRICALS LIMITED. IT MUST NOT BE USED DIRECTLY
OR INDIRECTLY IN ANY WAY DETRIMENTAL TO THE INTEREST OF COMPANY.

FIRST ANGLE PROJECTION

(ALL DIMENSIONS ARE IN mm)

FORM DG38(B)

DRAWING No. R8389-0761

6.3
✓ THE REST

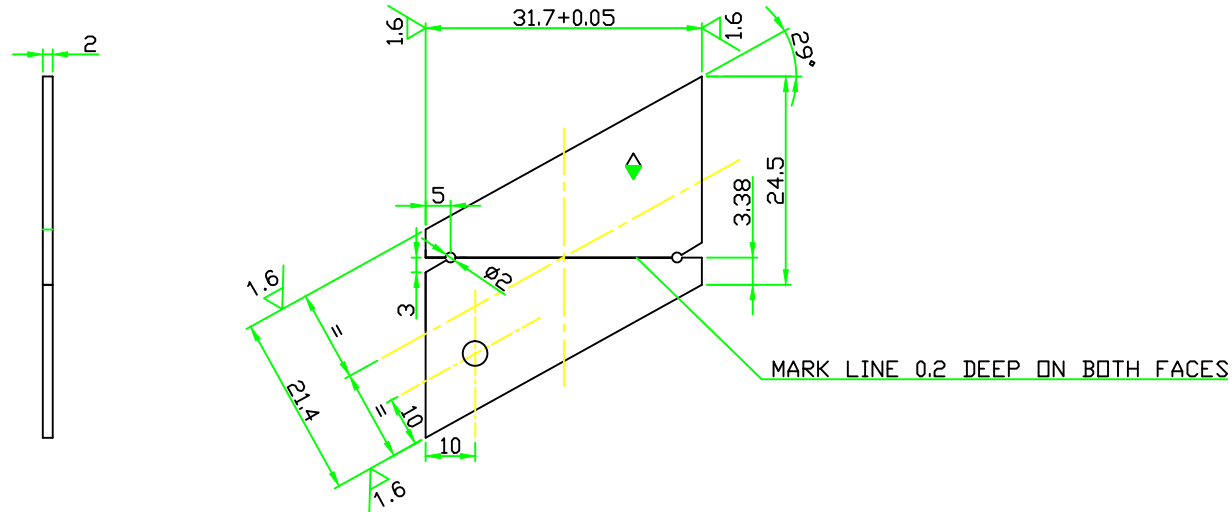

NOTES:-

- 1-MANUFACTURING ACCURACY ±0.05.
- 2-SHARP EDGES TO BE ROUNDED OFF.
- 3-CONSERVATION IS TO BE DONE AS PER TL 30007.
- *4-ALTERNATELY MATL AI5083,113H USED FOR DEFENCE PROJECT CAN BE USED WITH t=5mm.

◆ MARK
 R8389-0761

VAR.00	REMARKS	ITEM No.	DESCRIPTION	STD	DRAWING No.	* X04Cr1Ni10Ti AA10740	A UNIT	UNIT WEIGHT	QTY.
								1	

GMS No./GR.SP.No.	STATUS OF DRG	TYPE OF PRODUCT	COMP. DRG. No.	M/C TOOL TRANS No.	REF. DRG. No.
TTX	08.05.14	228MW	31010713021,01010113000	934	R8389-0693
AGREED DEPT.	NAME	SIGN.	DATE	DESIGN ORDER No.	M/C MODEL No.
TTX	SURINDER KUMAR	-Sd-	08.05.14	ST/6050	934

GRADE OF UNTOL. DIM.:-
M/CG- L /W/F AA0230208
WELDING-A/B/C/D AA0621104
GAS CUTTING-'T3' AA0621101

	BHARAT HEAVY ELECTRICALS LTD. HARDWAR			No. OF VAR.
	DRN	NAME	SIGN.	DATE
	CHD	MUKESH	-Sd-	08.05.14
APD	ANKUR	-Sd-	10.05.14	

REV	DATE	ALTERED	REV	DATE	ALTERED
		CHECKED			CHECKED

DEPT. JTE	SCALE	WEIGHT(Kg)	REF.TO ASSY. DRG.	ITEM No. OF
CODE 209	N.T.S.	0.03		ITEMS

TITLE	DRAWING No.	REV
MARKING&CHECKING TEMPLATE FOR INSERTION GROOVE STAGE NO.-15	R8389-0761	
SHEET No. 01	No. OF SHEETS 01	

SIZE A 3

COPYRIGHT AND CONFIDENTIAL
THE INFORMATION ON THIS DOCUMENT IS THE PROPERTY OF BHARAT
HEAVY ELECTRICALS LIMITED. IT MUST NOT BE USED DIRECTLY
OR INDIRECTLY IN ANY WAY DETRIMENTAL TO THE INTEREST OF COMPANY.

FIRST ANGLE PROJECTION

(ALL DIMENSIONS ARE IN mm)

FORM DG38(B)

DRAWING No. R8389-0759

6.3/
THE REST

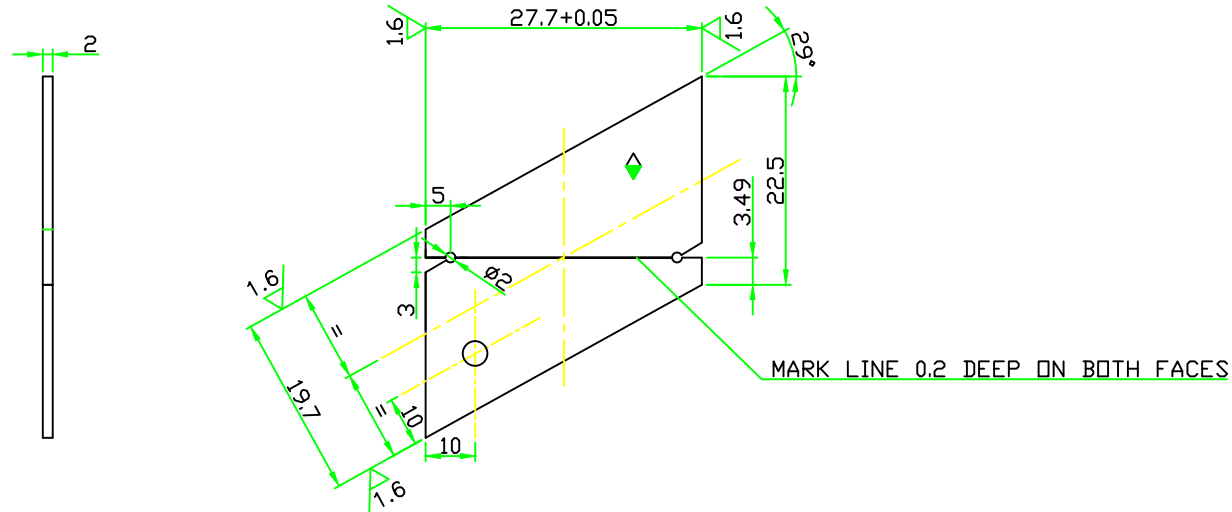

◇ MARK
R8389-0759

NOTES:-

- 1-MANUFACTURING ACCURACY ± 0.05 .
- 2-SHARP EDGES TO BE ROUNDED OFF.
- 3-CONSERVATION IS TO BE DONE AS PER TL 30007.
- *4-ALTERNATELY MATL AI5083,113H USED FOR DEFENCE PROJECT CAN BE USED WITH $t=5\text{mm}$.

VAR.00	REMARKS	ITEM No.	DESCRIPTION	STD	DRAWING No.	* X04Cr1Ni10Ti AA10740	A UNIT	UNIT WEIGHT	QTY.
								1	

GMS No./GR.SP.No.	STATUS OF DRG	TYPE OF PRODUCT	COMP. DRG. No.	M/C TOOL TRANS No.	REF. DRG. No.
TTX	08.05.14	228MW	31010713021,01010113000	934	R8389-0693
AGREED DEPT.	NAME	SIGN.	DATE	DESIGN ORDER No.	M/C MODEL No.
TTX	SURINDER KUMAR	-Sd-	08.05.14	ST/6048	934

GRADE OF UNTOL. DIM.:-
M/CG- L /W/F AA0230208
WELDING-A/B/C/D AA0621104
GAS CUTTING-'T3' AA0621101

	BHARAT HEAVY ELECTRICALS LTD.			No. OF VAR.
	HARDWAR			
	DRN	NAME	SIGN.	
CHD	MUKESH	-Sd-	08.05.14	No. OF ITEMS
APD	ANKUR	-Sd-	10.05.14	

REV	DATE	ALTERED	REV	DATE	ALTERED
		CHECKED			CHECKED

DEPT. JTE	SCALE	WEIGHT(Kg)
CODE 209	N.T.S.	0.03

REF.TO ASSY. DRG.	ITEM No.

TITLE	DRAWING No.	REV
MARKING&CHECKING TEMPLATE FOR INSERTION GROOVE STAGE NO.-9,10&11	R8389-0759	
SHEET No. 01	No. OF SHEETS 01	

SIZE A 3

COPYRIGHT AND CONFIDENTIAL
THE INFORMATION ON THIS DOCUMENT IS THE PROPERTY OF BHARAT
HEAVY ELECTRICALS LIMITED. IT MUST NOT BE USED DIRECTLY
OR INDIRECTLY IN ANY WAY DETRIMENTAL TO THE INTEREST OF COMPANY.

FIRST ANGLE PROJECTION

(ALL DIMENSIONS ARE IN mm)

FORM DG38(B)

DRAWING No. R8389-0758

6.3/
THE REST

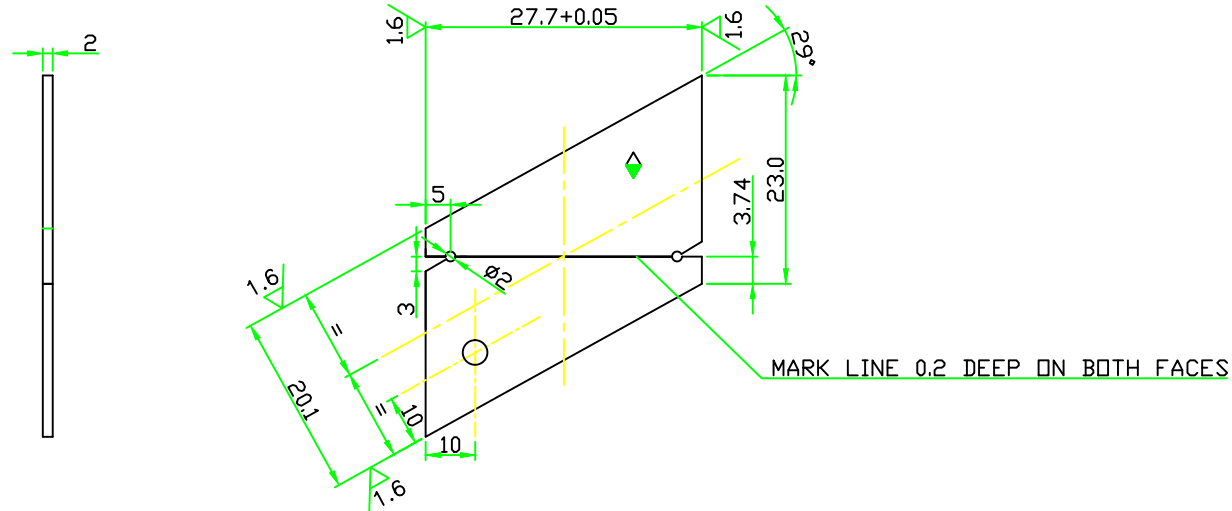

◇ MARK
R8389-0758

NOTES:-

- 1-MANUFACTURING ACCURACY ±0.05.
- 2-SHARP EDGES TO BE ROUNDED OFF.
- 3-CONSERVATION IS TO BE DONE AS PER TL 30007.
- *4-ALTERNATELY MATL AI5083,113H USED FOR DEFENCE PROJECT CAN BE USED WITH t=5mm.

VAR.00	REMARKS	ITEM No.	DESCRIPTION	STD	DRAWING No.	* X04Cr1Ni10Ti AA10740	A	UNIT	UNIT WEIGHT	QTY.
									1	

GMS No./GR.SP.No.	STATUS OF DRG	TYPE OF PRODUCT	COMP. DRG. No.	M/C TOOL TRANS No.	REF. DRG. No.
TTX	08.05.14	228MW	31010713021,01010113000	934	R8389-0693
AGREED DEPT.	NAME	SIGN.	DATE	DESIGN ORDER No.	M/C MODEL No.
TTX	SURINDER KUMAR	-Sd-	08.05.14	ST/6047	934

GRADE OF UNTOL. DIM.:-
M/CG- L /W/F AA0230208
WELDING-A/B/C/D AA0621104
GAS CUTTING-'T3' AA0621101

	BHARAT HEAVY ELECTRICALS LTD.			No. OF VAR.
	HARDWAR			
	DRN	NAME	SIGN.	
CHD	MUKESH	-Sd-	08.05.14	No. OF ITEMS
APD	ANKUR	-Sd-	10.05.14	

REV	DATE	ALTERED	REV	DATE	ALTERED
		CHECKED			CHECKED

DEPT. JTE	SCALE	WEIGHT(Kg)
CODE 209	N.T.S.	0.03

REF.TO ASSY. DRG.	ITEM No.
	OF

TITLE	DRAWING No.	REV
MARKING&CHECKING TEMPLATE	R8389-0758	
FOR INSERTION GROOVE STAGE NO.-3	SHEET No. 01	No. OF SHEETS 01

SIZE A 3

COPYRIGHT AND CONFIDENTIAL
THE INFORMATION ON THIS DOCUMENT IS THE PROPERTY OF BHARAT
HEAVY ELECTRICALS LIMITED. IT MUST NOT BE USED DIRECTLY
OR INDIRECTLY IN ANY WAY DETRIMENTAL TO THE INTEREST OF COMPANY.

FIRST ANGLE PROJECTION

(ALL DIMENSIONS ARE IN mm)

FORM DG38(B)

DRAWING No. R8389-0757

6.3
THE REST

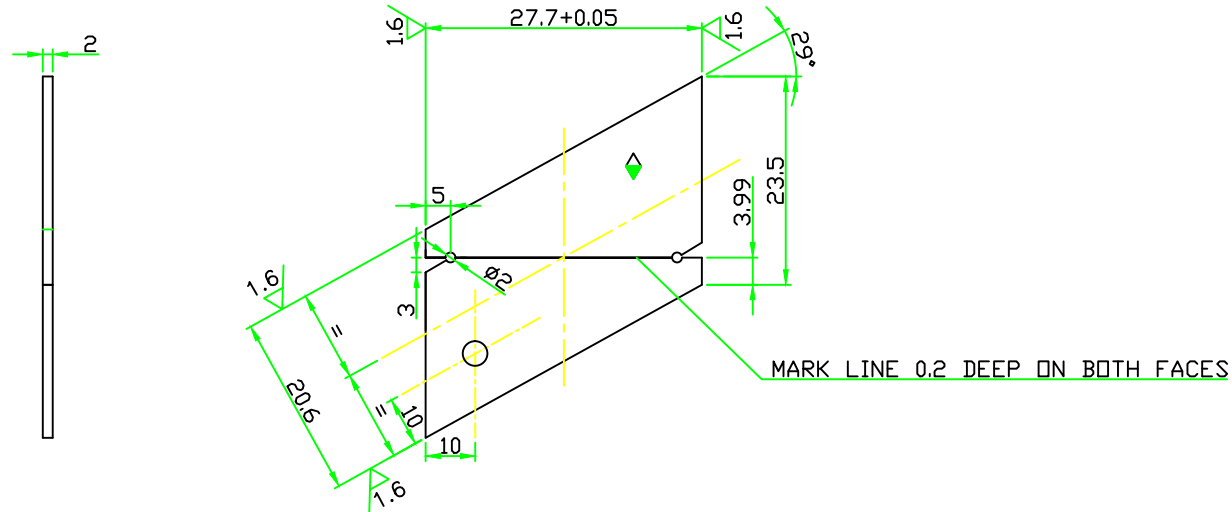

◇ MARK
R8389-0757

NOTES:-

- 1-MANUFACTURING ACCURACY ± 0.05 .
- 2-SHARP EDGES TO BE ROUNDED OFF.
- 3-CONSERVATION IS TO BE DONE AS PER TL 30007.
- *4-ALTERNATELY MATL AI5083,113H USED FOR DEFENCE PROJECT CAN BE USED WITH t=5mm.

VAR.00	REMARKS	ITEM No.	DESCRIPTION	STD	DRAWING No.	* X04Cr1Ni10Ti AA10740	A	UNIT	UNIT WEIGHT	QTY.
									1	

GMS No./GR.SP.No.		STATUS OF DRG		TYPE OF PRODUCT		COMP. DRG. No.		M/C TOOL TRANS No.		REF. DRG. No.	
TTX		SURINDER KUMAR -Sd-		08.05.14		228MW		31010713021,01010113000		R8389-0693	
AGREED DEPT.		NAME		SIGN.		DATE		DESIGN ORDER No.		M/C MODEL No.	
TTX		SURINDER KUMAR		-Sd-		08.05.14		ST/6046		934	
GRADE OF UNTOL. DIM.:-			M/CG- Z /W/F AA0230208			WELDING-A/B/C/D AA0621104			GAS CUTTING-'T3' AA0621101		
REV	DATE	ALTERED	REV	DATE	ALTERED	DEPT. JTE	SCALE	WEIGHT(Kg)	REF.TO ASSY. DRG.		ITEM No. OF
		CHECKED			CHECKED	209	N.T.S.	0.03			No. OF
						TITLE			DRAWING No.		REV
						MARKING&CHECKING TEMPLATE FOR			R8389-0757		
						INSERTION GROOVE(STAGE 1&2)			SHEET No. 01		No. OF SHEETS 01

INVENTORY No. SIGN.&DATE REF. DRG. No.

COPYRIGHT AND CONFIDENTIAL
THE INFORMATION ON THIS DOCUMENT IS THE PROPERTY OF BHARAT
HEAVY ELECTRICALS LIMITED IT MUST NOT BE USED DIRECTLY
OR INDIRECTLY IN ANY WAY DETRIMENTAL TO THE INTEREST OF COMPANY.

FIRST ANGLE PROJECTION

(ALL DIMENSIONS ARE IN mm)

FORM DG38(B)

DRAWING No. R8381-1878

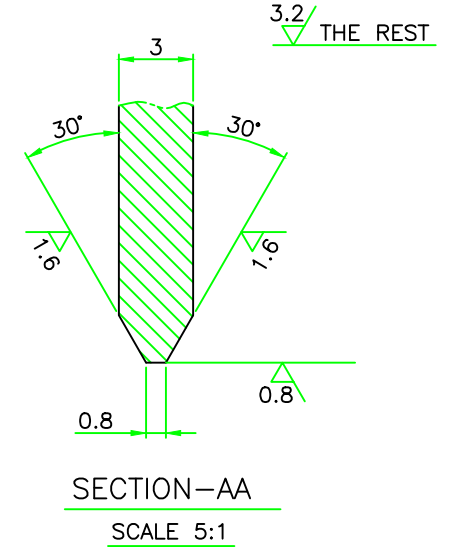
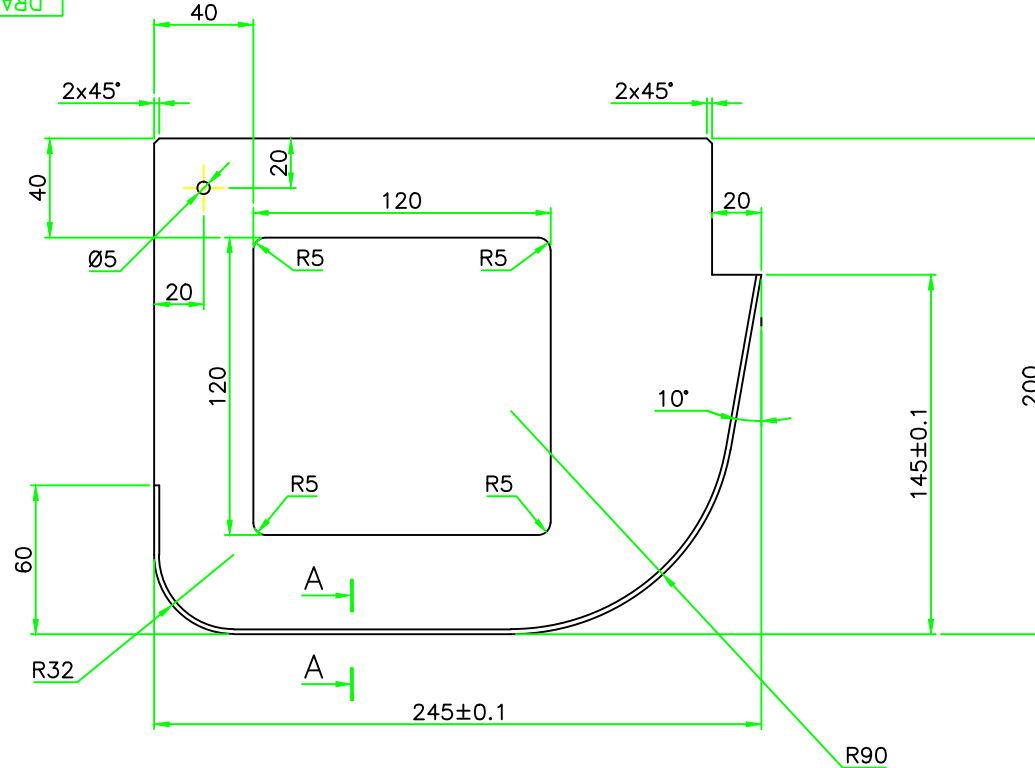

MARK
R8381-1878

NOTES:-

1- SHARP EDGES TO BE ROUNDED OFF.

2-HARDEN TO HRc 50±55 AS PER PS 0912-008.

3-CONSERVATION TO BE DONE AS PER TL 30007.

VAR.00	REMARKS	ITEM No.	DESCRIPTION	STD	DRAWING No.	T90Mn6WCr2 AA10821	A	UNIT	UNIT WEIGHT	QTY.
--------	---------	----------	-------------	-----	-------------	-----------------------	---	------	-------------	------

GMS No./GR.SP.No.	STATUS OF DRG	TYPE OF PRODUCT	COMP. DRG. No.	M/C TOOL TRANS No.	REF. DRG. No.
TTX	SURINDER -Sd- 14.06.14	ST 228MW	01010113000	169	
AGREED DEPT.	NAME	SIGN.	DATE	DESIGN ORDER No.	M/C MODEL No.
TTX	SURINDER	-Sd-	14.06.14	ST/6059	LATHE

GRADE OF UNTOL. DIM.:-	
M/CG- L /M/F	AA0230208
WELDING-A/B/C/D AA0621104	
GAS CUTTING-'T3' AA0621101	

BHEL BHARAT HEAVY ELECTRICALS LTD.
HARDWAR

DRN	NAME	SIGN.	DATE	No. OF VAR.
CHD	RAJESH	-Sd-	14.06.14	
APD	RAVI	-Sd-	14.06.14	
	ANKUR	-Sd-	14.06.14	

REV	DATE	ALTERED	REV	DATE	ALTERED
		CHECKED			CHECKED

DEPT. JTE
CODE 209

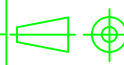

SCALE 1:2
WEIGHT(Kg) ~0.71

REF.TO ASSY. DRG.
ITEM No. OF No. ITEMS

TITLE TEMPLATE FOR CHECKING
R90&R32 ZONE L-9

DRAWING No. R8381-1878
REV

SHEET No. 01 | No. OF SHEETS 01

SIZE A 3

INVENTORY No. SIGN.&DATE REF. DRG. No.

COPYRIGHT AND CONFIDENTIAL
THE INFORMATION ON THIS DOCUMENT IS THE PROPERTY OF BHARAT
HEAVY ELECTRICALS LIMITED IT MUST NOT BE USED DIRECTLY
OR INDIRECTLY IN ANY WAY DETRIMENTAL TO THE INTEREST OF COMPANY.

FIRST ANGLE PROJECTION

(ALL DIMENSIONS ARE IN mm)

FORM DG38(B)

DRAWING No. R8381-1877

3.2/
THE REST

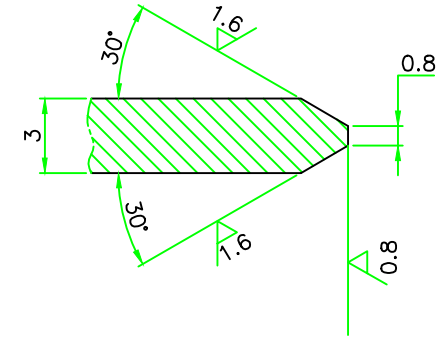
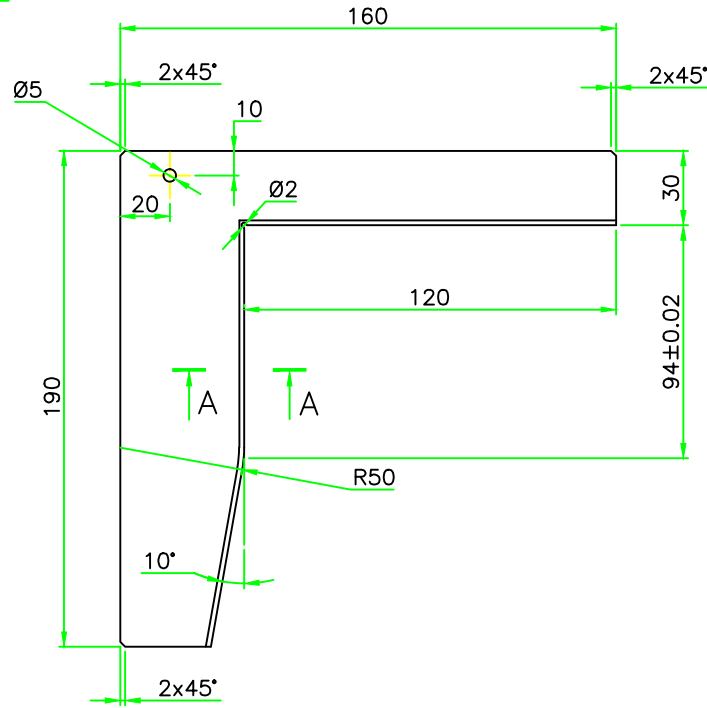

SECTION-AA

SCALE 5:1

MARK
R8381-1877

NOTES:-

1- SHARP EDGES TO BE ROUNDED OFF.

2-HARDEN TO HRc 50±55 AS PER PS 0912-008.

3-CONSERVATION TO BE DONE AS PER TL 30007.

VAR.00	REMARKS	ITEM No.	DESCRIPTION	STD	DRAWING No.	T90Mn6WCr2 AA10821	MATERIAL CODE	A	UNIT	UNIT WEIGHT	QTY.
							MATERIAL SPECN.	c			

GMS No./GR.SP.No.	STATUS OF DRG	TYPE OF PRODUCT	COMP. DRG. No.	M/C TOOL TRANS No.	REF. DRG. No.
TTX	SURINDER -Sd- 14.06.14	ST 228MW	01010113000	169	
AGREED DEPT.	NAME	SIGN.	DATE	DESIGN ORDER No.	M/C MODEL No.
TTX	SURINDER	-Sd-	14.06.14	ST/6058	LATHE

GRADE OF UNTOL. DIM.:-
M/CG- L /M/F AA0230208
WELDING-A/B/C/D AA0621104
GAS CUTTING-'T3' AA0621101

BHEL BHARAT HEAVY ELECTRICALS LTD.
HARDWAR

DRN	NAME	SIGN.	DATE	No. OF VAR.
CHD	RAJESH	-Sd-	14.06.14	
APD	RAVI	-Sd-	14.06.14	
	ANKUR	-Sd-	14.06.14	

REV	DATE	ALTERED	REV	DATE	ALTERED
		CHECKED			CHECKED

DEPT.	JTE	SCALE	WEIGHT(Kg)
CODE	209	1:2	~0.25

REF.TO ASSY. DRG.	ITEM No. OF
	No. ITEMS

TITLE TEMPLATE FOR CHECKING R50
WITH TAPER 10°, ZONE J-8

DRAWING No.
R8381-1877

SHEET No. 01 | No. OF SHEETS 01

SIZE A 3

INVENTORY No. SIGN.&DATE REF. DRG. No.

COPYRIGHT AND CONFIDENTIAL
THE INFORMATION ON THIS DOCUMENT IS THE PROPERTY OF BHARAT
HEAVY ELECTRICALS LIMITED IT MUST NOT BE USED DIRECTLY
OR INDIRECTLY IN ANY WAY DETRIMENTAL TO THE INTEREST OF COMPANY.

FIRST ANGLE PROJECTION

(ALL DIMENSIONS ARE IN mm)

FORM DG38(B)

DRAWING No. R8381-1876

3.2/
THE REST

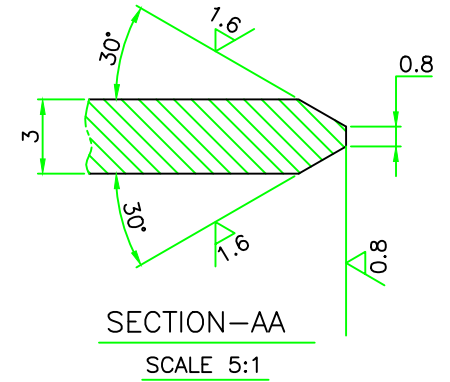
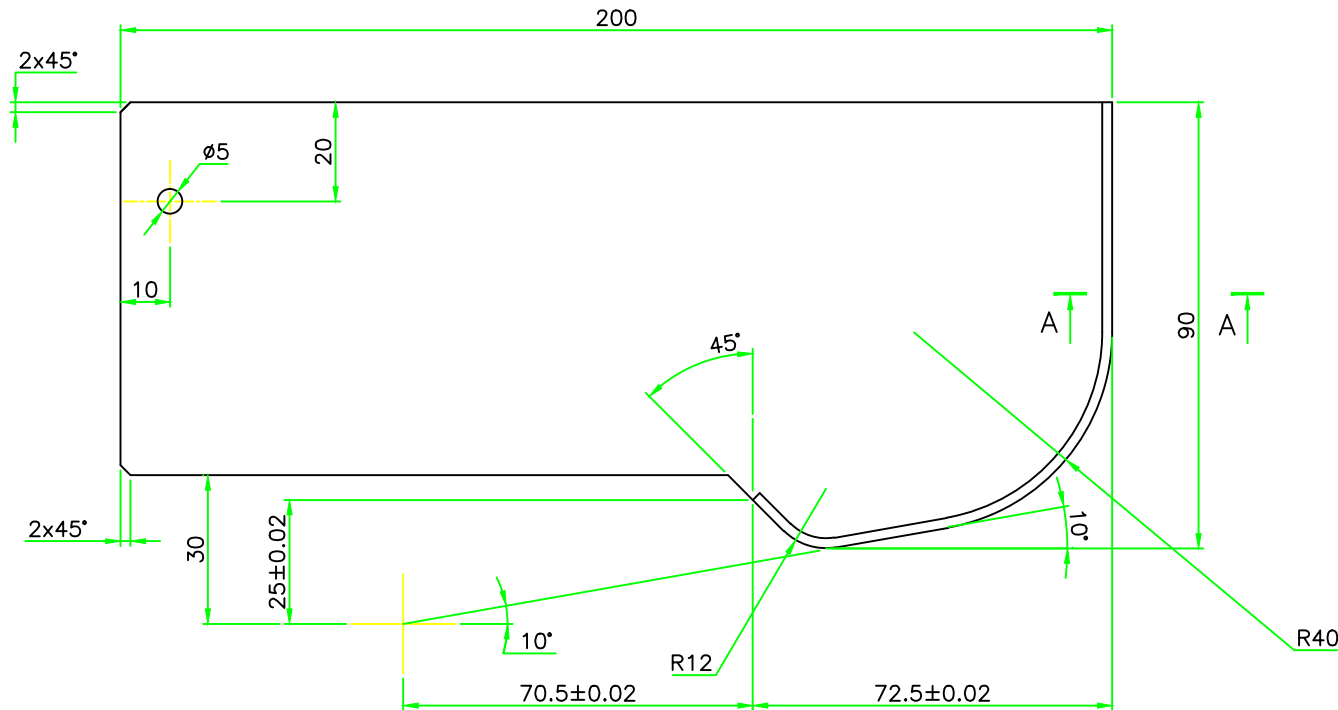

MARK
R8381-1876

NOTES:-

- 1- SHARP EDGES TO BE ROUNDED OFF.
- 2-HARDEN TO HRc 50:55 AS PER PS 0912-008.
- 3-CONSERVATION TO BE DONE AS PER TL 30007.

VAR.00	REMARKS	ITEM No.	DESCRIPTION	QTY	DRAWING No.	T90Mn6WCr2 AA10821	MATERIAL CODE	A	UNIT	UNIT WEIGHT	g
						VAR.	MATERIAL SPECN.	c		QTY.	

GMS No./GR.SP.No.	STATUS OF DRG	TYPE OF PRODUCT	COMP. DRG. No.	M/C TOOL TRANS No.	REF. DRG. No.
AGREED DEPT.	NAME	SIGN.	DATE	ST 228MW	01010113000
TTX	SURINDER	-Sd-	07.06.14	DESIGN ORDER No.	ST/6057
				M/C MODEL No.	LATHE

GRADE OF UNTOL. DIM.:-	
M/CG- L /M/F	AA0230208
WELDING-A/B/C/D AA0621104	
GAS CUTTING-'T3' AA0621101	

BHEL BHARAT HEAVY ELECTRICALS LTD.
HARDWAR

DRN	NAME	SIGN.	DATE	No. OF VAR.
CHD	RAJESH	-Sd-	07.06.14	
APD	RAVI	-Sd-	07.06.14	
	ANKUR	-Sd-	07.06.14	

REV	DATE	ALTERED	REV	DATE	ALTERED
		CHECKED			CHECKED

DEPT.	JTE	SCALE	WEIGHT(Kg)
CODE	209	1:1	~0.36

REF.TO ASSY. DRG.	ITEM No. OF
	No. ITEMS

TITLE TEMPLATE FOR CHECKING R40 WITH 10°
R12 WITH TAPER 45°&R40,ZONE L-8

DRAWING No.
R8381-1876

SHEET No. 01 | No. OF SHEETS 01

SIZE A 3

INVENTORY No. SIGN.&DATE REF. DRG. No.

COPYRIGHT AND CONFIDENTIAL
THE INFORMATION ON THIS DOCUMENT IS THE PROPERTY OF BHARA
HEAVY ELECTRICALS LIMITED IT MUST NOT BE USED DIRECTLY
OR INDIRECTLY IN ANY WAY DETRIMENTAL TO THE INTEREST OF COMPANY

DRAWING No. R8381-1875

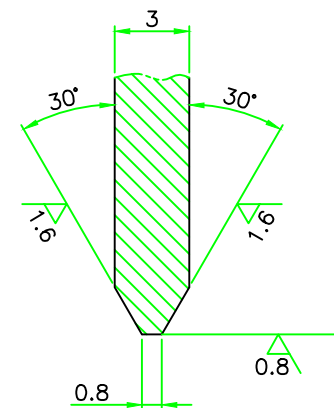
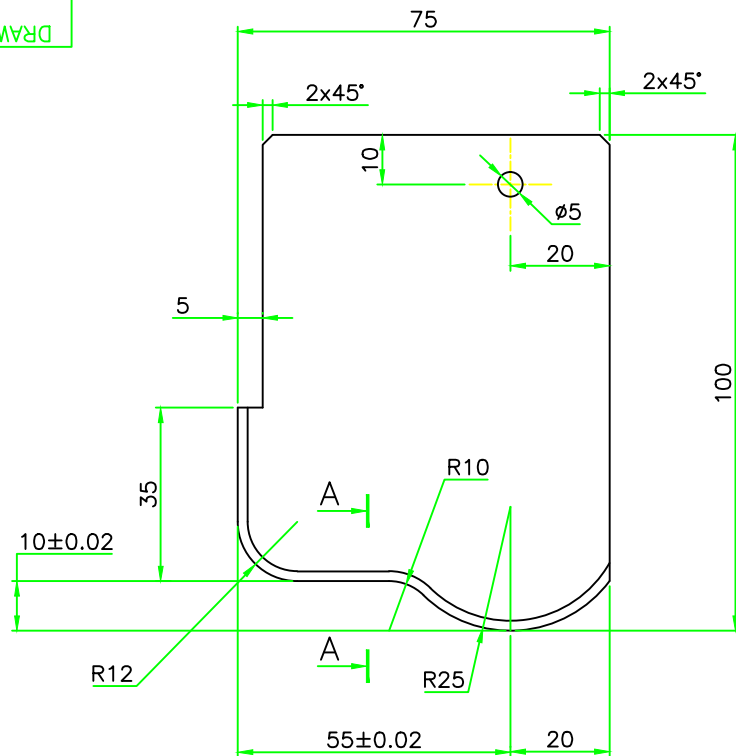

SECTION-AA
SCALE 5:1

3.2/ THE REST

◆ MARK
R8381-1875

NOTES:-

- 1- SHARP EDGES TO BE ROUNDED OFF.
- 2-HARDEN TO HRc 50±55 AS PER PS 0912-008.
- 3-CONSERVATION TO BE DONE AS PER TL 30007.

VAR.00	REMARKS	ITEM No.	DESCRIPTION	STD	DRAWING No.	T90Mn6WCr2 AA10821	MATERIAL CODE	A	UNIT	UNIT WEIGHT	
VAR.	MATERIAL SPECN.	C	QTY.								

GMS No./GR.SP.No.		STATUS OF DRG		TYPE OF PRODUCT		COMP. DRG. No.		M/C TOOL TRANS No.		REF. DRG. No.	
TTX		SURINDER -Sd-		14.06.14		ST 228MW		01010113000		169	
DESIGN ORDER No.		M/C MODEL No.									
ST/6056		LATHE									
AGREED DEPT.		NAME		SIGN.		DATE		DRN		No. OF VAR.	
TTX		SURINDER		-Sd-		14.06.14		RAJESH		-Sd-	
CHD		RABI		-Sd-		14.06.14		APD		ANKUR	
APD		ANKUR		-Sd-		14.06.14					
REV		DATE		ALTERED		REV		DATE		ITEM No. OF No. ITEMS	
				CHECKED							
DEPT. JTE		SCALE		WEIGHT(Kg)		REF.TO ASSY. DRG.		DRAWING No.		REV	
CODE 209		1:1		~0.15				R8381-1875			
TITLE		DRAWING No.		SHEET No. 01		No. OF SHEETS 01					
TEMPLATE FOR CHECKING		R20 WITH DIM=55,DETAIL-IX									

BHEL BHARAT HEAVY ELECTRICALS LTD.
HARDWAR

SIZE A 3

COPYRIGHT AND CONFIDENTIAL
 THE INFORMATION ON THIS DOCUMENT IS THE PROPERTY OF BHARAT
 HEAVY ELECTRICALS LIMITED IT MUST NOT BE USED DIRECTLY
 OR INDIRECTLY IN ANY WAY DETRIMENTAL TO THE INTEREST OF COMPANY.

FIRST ANGLE PROJECTION

(ALL DIMENSIONS ARE IN mm)

FORM DG38(B)

DRAWING No. R8381-1874

3.2 / THE REST

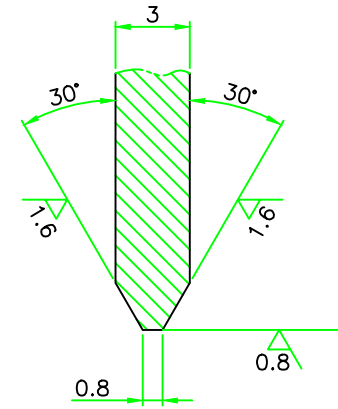
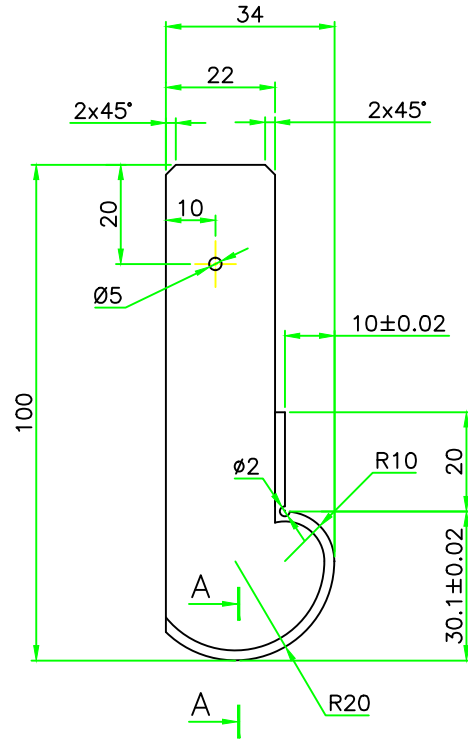

SECTION-AA

SCALE 5:1

MARK
 R8381-1874

NOTES:-

1- SHARP EDGES TO BE ROUNDED OFF.

2-HARDEN TO HRc 50±55 AS PER PS 0912-008.

3-CONSERVATION TO BE DONE AS PER TL 30007.

VAR.00	REMARKS	ITEM No.	DESCRIPTION	STD	DRAWING No.	T90Mn6WCr2 AA10821	MATERIAL CODE	A	UNIT	UNIT WEIGHT	QTY.

GMS No./GR.SP.No.	STATUS OF DRG	TYPE OF PRODUCT	COMP. DRG. No.	M/C TOOL TRANS No.	REF. DRG. No.
TTX		ST 228MW	01010113000	169	
AGREED DEPT.	NAME	SIGN.	DATE	DESIGN ORDER No.	M/C MODEL No.
TTX	SURINDER	-Sd-	14.06.14	ST/6055	LATHE

GRADE OF UNTOL. DIM.:-
M/CG- V /M/F AA0230208
WELDING-A/B/C/D AA0621104
GAS CUTTING-'T3' AA0621101

BHARAT HEAVY ELECTRICALS LTD. HARDWAR	DRN	NAME	SIGN.	DATE	No. OF VAR.
	CHD	RAJESH	-Sd-	14.06.14	
	APD	RAVI	-Sd-	14.06.14	
		ANKUR	-Sd-	14.06.14	

REV	DATE	ALTERED	REV	DATE	ALTERED
		CHECKED			CHECKED

DEPT. JTE	SCALE	WEIGHT(Kg)	REF.TO ASSY. DRG.	ITEM No. OF
CODE 209	1:1	~0.06		ITEMS

TITLE	DRAWING No.	REV
TEMPLATE FOR CHECKING R20 WITH R10,DETAIL-II	R8381-1874	

SHEET No. 01	No. OF SHEETS 01
--------------	------------------

SIZE A 3

INVENTORY No. SIGN.&DATE REF. DRG. No.

COPYRIGHT AND CONFIDENTIAL
THE INFORMATION ON THIS DOCUMENT IS THE PROPERTY OF BHARAT
HEAVY ELECTRICALS LIMITED IT MUST NOT BE USED DIRECTLY
OR INDIRECTLY IN ANY WAY DETRIMENTAL TO THE INTEREST OF COMPANY.

FIRST ANGLE PROJECTION

(ALL DIMENSIONS ARE IN mm)

FORM DG38(B)

DRAWING No. R8381-1873

3.2/
THE REST

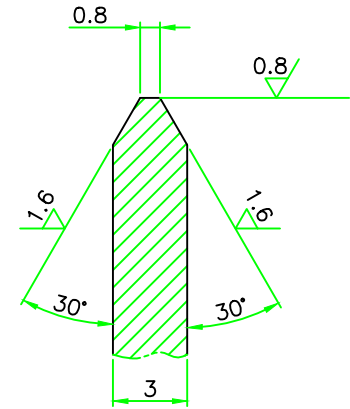
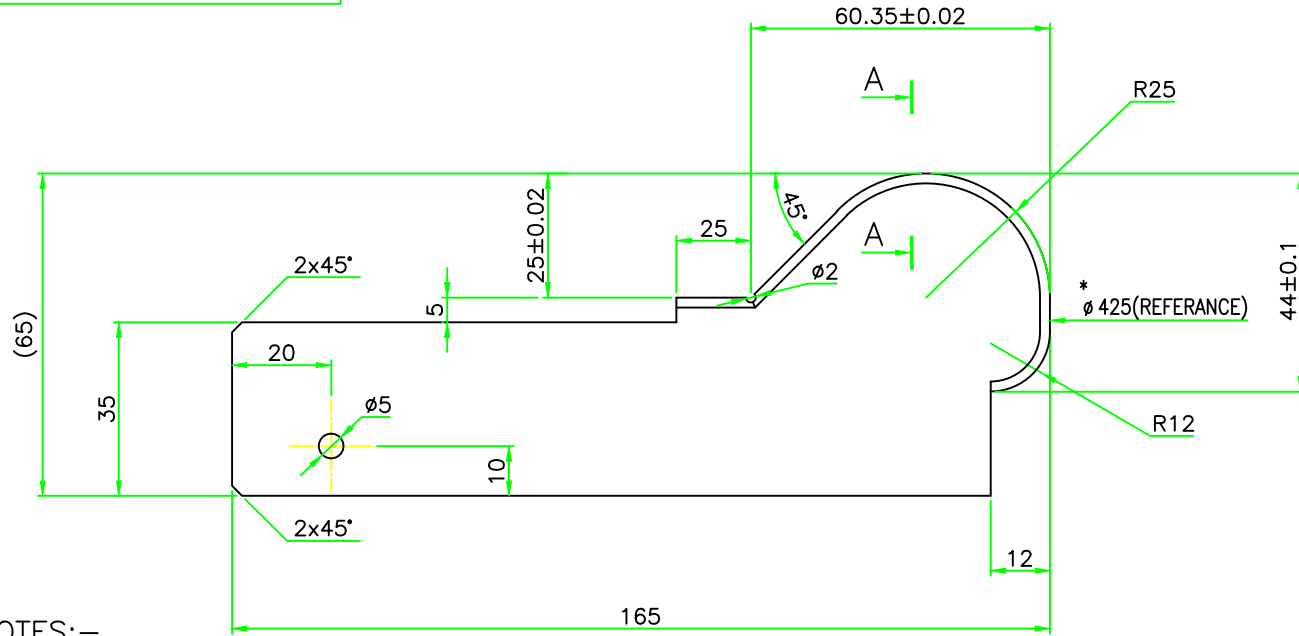

SECTION-AA

SCALE 5:1

MARK
R8381-1873

NOTES:-

- 1- SHARP EDGES TO BE ROUNDED OFF.
- *2-R25 WITH 45° TO BE CHECKED IN ONE TIME &
R12 TO CHECKED IN SECOND TIME WITH RESPECT TO Ø425.
- 3-HARDEN TO HRc 50±55 AS PER PS 0912-008.
- 4-CONSERVATION TO BE DONE AS PER TL 30007.

VAR.00	REMARKS	ITEM No.	DESCRIPTION	STD	DRAWING No.	T90Mn6WCr2 AA10821	A	UNIT	UNIT WEIGHT	g
						MATERIAL CODE	c		QTY.	
						MATERIAL SPECN.				

GMS No./GR.SP.No.	STATUS OF DRG	TYPE OF PRODUCT	COMP. DRG. No.	M/C TOOL TRANS No.	REF. DRG. No.
AGREED DEPT.	NAME	SIGN.	DATE	ST 228MW	01010113000
TTX	SURINDER	-Sd-	14.06.14	DESIGN ORDER No.	ST/6054
				M/C MODEL No.	LATHE

GRADE OF UNTOL. DIM.:-	
M/CG- V /M/F	AA0230208
WELDING-A/B/C/D	AA0621104
GAS CUTTING-'T3'	AA0621101

	BHARAT HEAVY ELECTRICALS LTD.		No. OF VAR.
	HARDWAR		
	DRN	RAJESH	
CHD	RAVI	-Sd-	14.06.14
APD	ANKUR	-Sd-	14.06.14

REV	DATE	ALTERED	REV	DATE	ALTERED
		CHECKED			CHECKED

DEPT.	JTE	SCALE	WEIGHT(Kg)
CODE	209	1:1	~0.16

REF.TO ASSY. DRG.	ITEM No. OF
	ITEMS

TITLE	DRAWING No.	REV
TEMPLATE FOR CHECKING R12,R25 WITH 45°,DETAIL-V	R8381-1873	

SHEET No. 01	No. OF SHEETS 01
--------------	------------------

SIZE A 3

DRAWING No. **R8381-1732**

FIRST ANGLE PROJECTION

(ALL DIMENSIONS ARE IN mm)

FORM DG38(B)

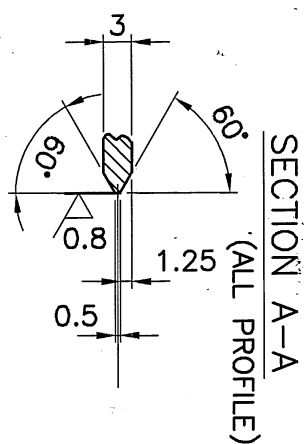
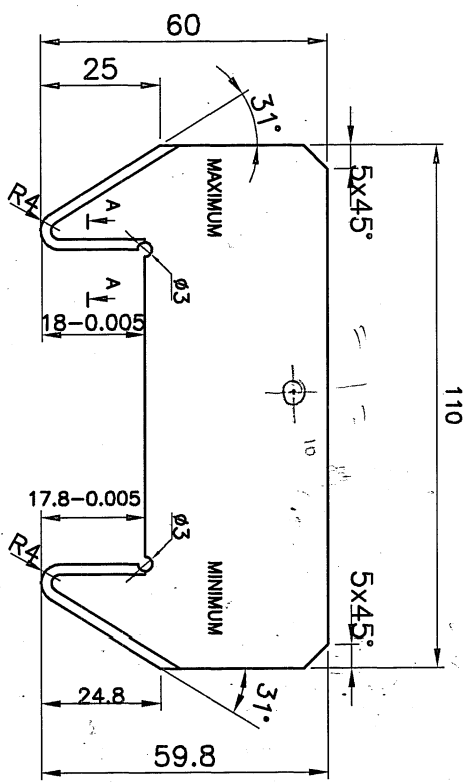

MARK
 R8381-1732
 STAGE 6L/R

- 1--SHARP EDGES TO BE ROUNDED OFF.
- 2--HARDEN TO HRC 50-55 AS PER P.S. No.0912-008.
- 3--MANUFACTURING ACCURACY OF TEMPLATE ±0.03 FOR PROFILE.
- 4--CONSERVATION AS PER TL-30007.

GRADE OF UNTOL. DIM.:-	M/CG- <i>φ</i> /M/E/AA0230208
WELDING-A/B/C/D	AA0621104
GAS CUTTING-T3	AA0621101
REV. DATE	ALTERED
	CHECKED

VAR.00	REMARKS	ITEM No.	DRAWING No.	DRAWING No.
59		28	59	59
61		28	59	59

AGREED DEPT. T.I.X	NAME	SIGN.	DATE	STATUS OF DRG.	CARD TYPE-1	TYPE OF PRODUCT	COMP. DRG. No.	DESIGN ORDER No.	M/C TOOL TRANS No.	REF. DRG. No.
	YPA		17/05	28	28	250 MW ST	9-10304-46000	KP250STSTMD197		

DRN	ANKUR	SIGN.	DATE	No. OF
CHD	ANKUR		24.7.05	VAR.
APD	BKR			

INVENTORY No.	SIGN.&DATE	REF. DRG. No.
M-19085	17.7.05	

TITLE: CHECKING TEMPLATE
 R4x31°
 DEPT. JTE
 CODE 209
 SCALE NTS
 WEIGHT(Kg) ~0.1
 DRAWING No. R8381-1732
 SHEET No. 01 No. OF SHEETS 01

SIZE A 3

900/02L1-1838R

ON SHIMVARDI/2222 222222

प्रथम कोण प्रक्षेपण / FIRST ANGLE PROJECTION

सर्वी विमाएँ मिलीमीटर में हैं / ALL DIMENSIONS ARE IN mm.

प्रारंभिक संख्या (शीट)/FORM 38 (B)

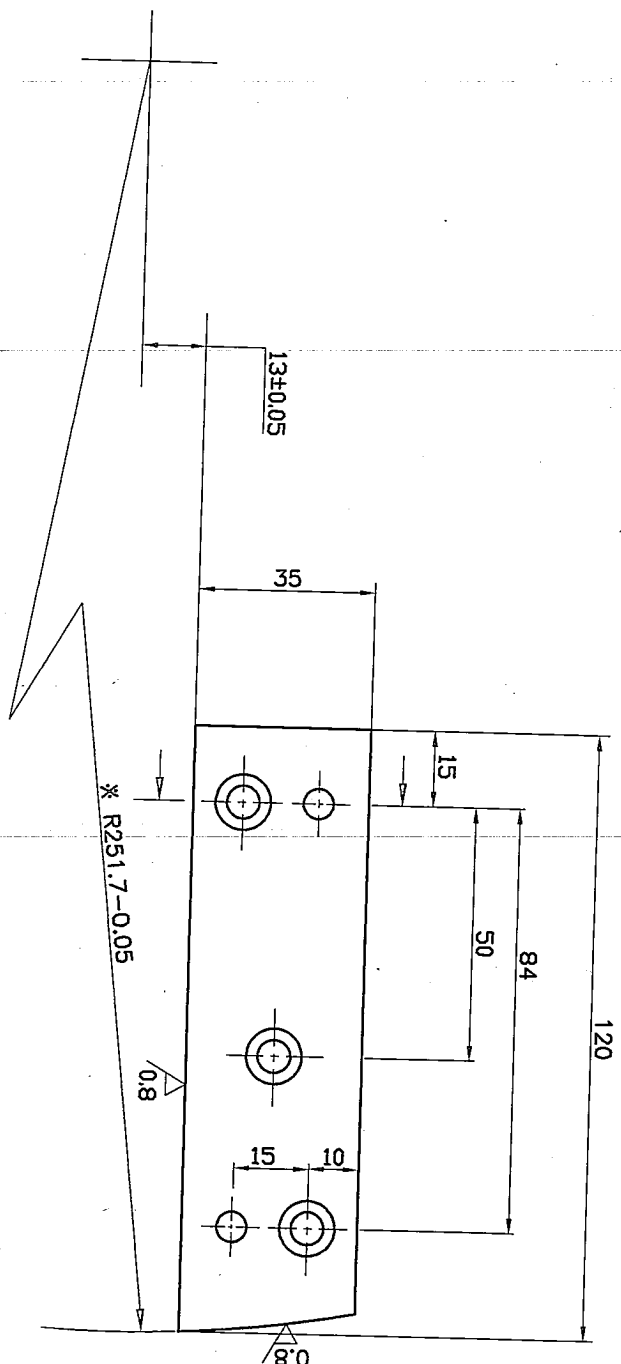

3 HOLES Ø6.5 TO BE DRILLED IN ASSLY.

2 HOLES Ø6H7 (+0.012) TO BE DRILLED IN ASSLY

6.3 / THE REST

1. SHARP EDGES TO BE ROUNDED OFF.
2. HARDEN TO HRC 50+55 AS PER PS 0912-008
3. * TO BE FINALLY GROUND IN ASSLY.

श्री.श्री.सो.दा./C.B.O.M.

GRADE OF UNTOL. DIM	M/CG. - AA0230208 Ø/M/Y
WELDING-CLASS 'B' OF AA0621104	
GAS CUTTING-TABLE 3 OF AA0621101	
REV. DATE	REV. DATE

श्री.श्री.सो.दा./C.B.O.M.	श्री.श्री.सो.दा./C.B.O.M.
श्री.श्री.सो.दा./C.B.O.M.	श्री.श्री.सो.दा./C.B.O.M.
श्री.श्री.सो.दा./C.B.O.M.	श्री.श्री.सो.दा./C.B.O.M.

उत्पाद का प्रकार
TYPE OF PRODUCT

भारत हेवी इलेक्ट्रिकल्स लिमिटेड, रामपुर, हरियाणा
BHARAT HEAVY ELECTRICALS LIMITED,
RAMPUR, HARYANWAR

T55S12Mn90	~0.4		
AISI: S4/3748	1		
MATERIAL CODE	UNIT WEIGHT		
MATERIAL SPECN	QTY		

श्री.श्री.सो.दा./C.B.O.M.
श्री.श्री.सो.दा./C.B.O.M.
श्री.श्री.सो.दा./C.B.O.M.
श्री.श्री.सो.दा./C.B.O.M.

श्री.श्री.सो.दा./C.B.O.M.
श्री.श्री.सो.दा./C.B.O.M.
श्री.श्री.सो.दा./C.B.O.M.
श्री.श्री.सो.दा./C.B.O.M.

PLATE UPPER

श्री.श्री.सो.दा./C.B.O.M.
श्री.श्री.सो.दा./C.B.O.M.
श्री.श्री.सो.दा./C.B.O.M.
श्री.श्री.सो.दा./C.B.O.M.

A3 शीट/A3 SIZE

THIS DOCUMENT IS THE PROPERTY OF BHARAT HEAVY ELECTRICALS LIMITED. IT MUST NOT BE USED DIRECTLY OR INDIRECTLY IN ANY WAY DETERIMENTAL TO THE INTEREST OF THE COMPANY.

REFERENCE DRG. NO.

INVENTORY NO.

2

200/021-1838

ON DRAWING/संकेत संख्या

प्रथम कोण संरक्षण / FIRST ANGLE PROTECTION

सभी विमाएँ मिलीमीटर में हैं / ALL DIMENSIONS ARE IN MM.

प्रथम कोण 38 (डी) / FORM 38 (B)

6.3 / THE REST

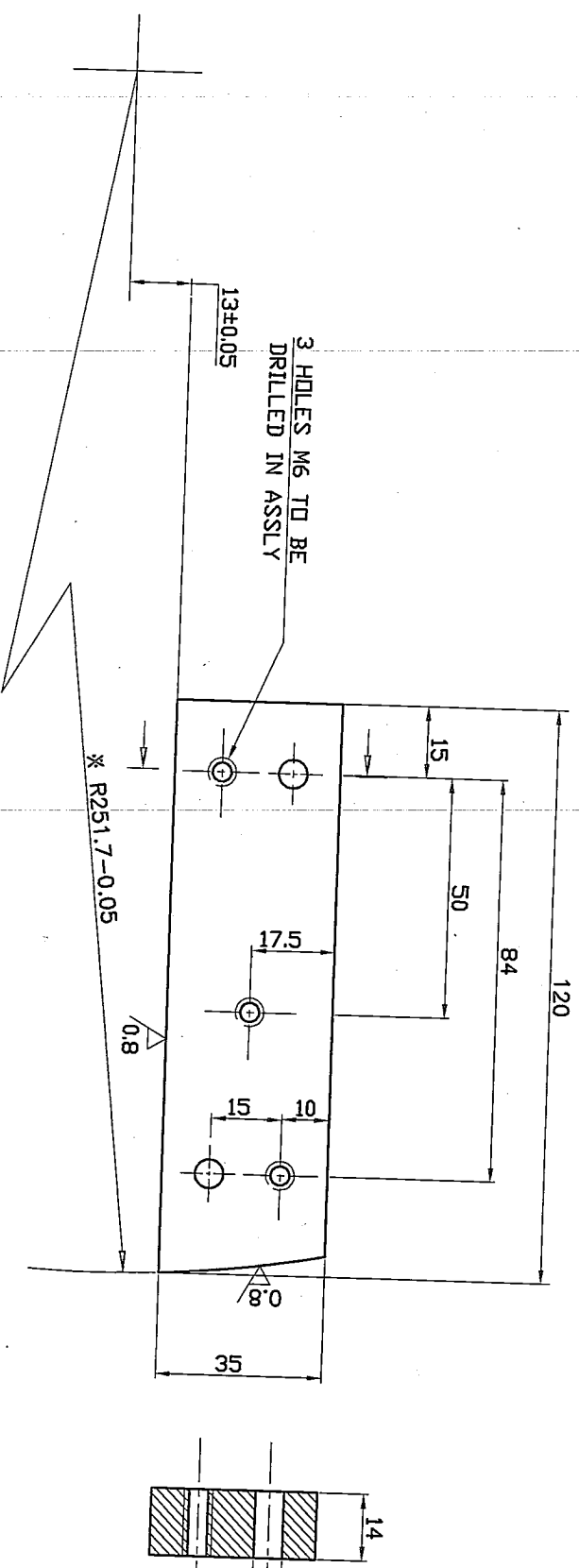

1. SHARP EDGES TO BE ROUNDED OFF.
2. HARDEN TO HRC 50+55 AS PER PS 0912-008
3. * TO BE FINALLY GROUND IN ASSLY.

T55S12Mn90	~0.4
AIISI: S4/3748	1
MATERIAL CODE	UNIT WEIGHT
MATERIAL SPECN	QTY

GRADE OF UNTOL. DIM	
M/CG.-- AA0230208 E/M/Y	
WELDING-CLASS 'B' OF AA0621104	
GAS CUTTING-TABLE 3 OF AA0621101	

संशोधन REV.	दिनांक DATE	परिवर्तित BY
----------------	----------------	-----------------

संशोधन REV.	दिनांक DATE	परिवर्तित BY
----------------	----------------	-----------------

उत्पाद का प्रकार
TYPE OF PRODUCT

भारत हेवी इलेक्ट्रिकल्स लिमिटेड, तानौर, हरियाणा
BHARAT HEAVY ELECTRICALS LIMITED,
RANIPUR, HARYANWAR

अनुपात / SCALE
1:1

भारत के.ग.
WEIGHT (KG)
~0.40

शीर्षक / TITLE
PLATE LOWER

नाम / NAME NAVEEN	हस्ताक्षर / SIGN	दिनांक / DATE
B.K.R.		

आदेशको संकेत / REFER TO ASSLY. DRG.

आदेश संख्या / DRAWING NO.
R8381-1720/002

आदेश संख्या / Sheets No. 01

कुल शीट संख्या / No. of Sheets 01

A3 आकार / A3 SIZE

THE PROPERTY OF BHARAT HEAVY ELECTRICALS LIMITED. IT MUST NOT BE USED DIRECTLY OR INDIRECTLY IN ANY WAY DETERIMENTAL TO THE INTEREST OF THE COMPANY.

REFERENCE DRG. NO.

16811

100/0201-1838R
 NO. 100/0201-1838R

प्रथम कोण प्रक्षेपण / FIRST ANGLE PROJECTION

सर्वीय आयाम / ALL DIMENSIONS ARE IN mm.

पृष्ठ संख्या 44 (01) / पृष्ठ 44 (0)

1. SHARP EDGES TO BE ROUNDED OFF
2. HARDEN TO HRC 50-55 AS PER IS 0812-008.
3. XTO BE FINALLY GROUND IN ASSLY-

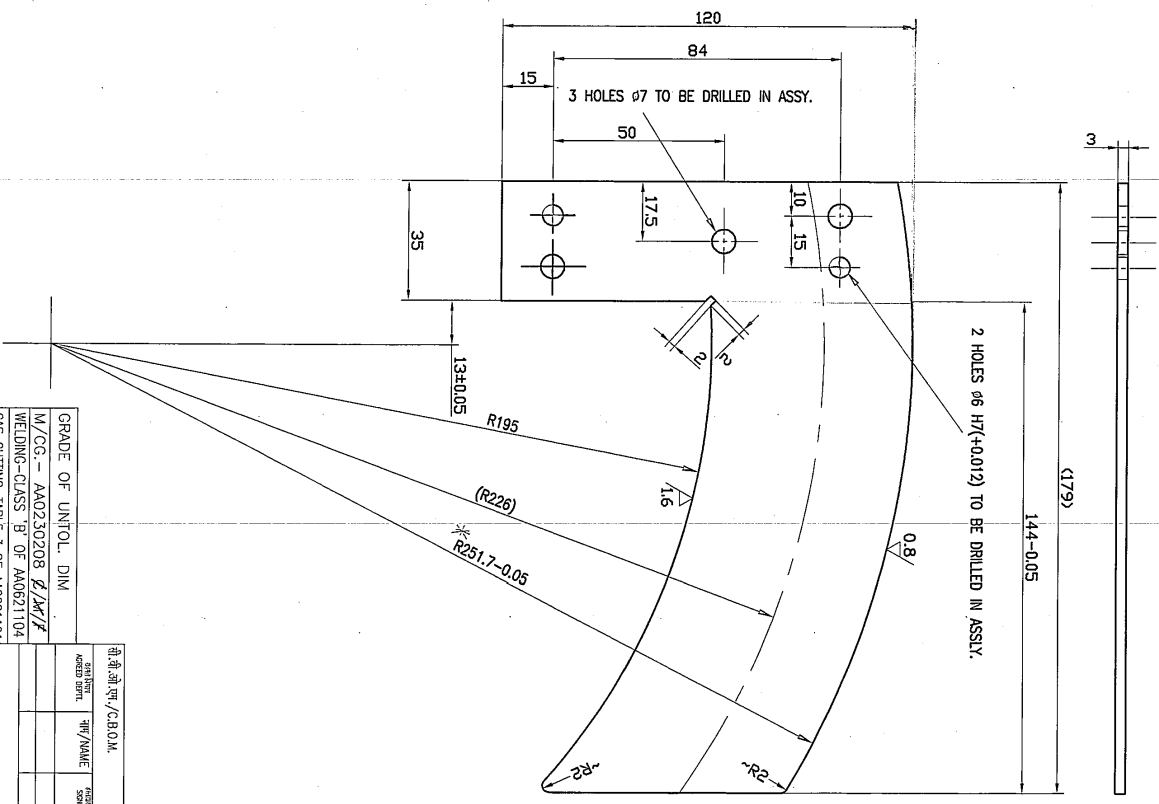

6.3 / THE REST

190M6WC2
 HW10982
 MATERIAL

GRADE OF UNTOL. DIM.
 W/CG - AA0230208 2/27/1
 WELDING-CLASS 'B' OF AA0821104
 CAS CUTTING-TABLE 3 OF AA0821101

क्र.सं. / REV.	परिवर्तन / REVISION	दिनांक / DATE	अनुमोदित / APPROVED BY

उत्पाद का प्रकार / TYPE OF PRODUCT	उत्पाद का नाम / PRODUCT NAME	उत्पाद का कोड / PRODUCT CODE	उत्पाद का वर्ग / PRODUCT CLASS
उत्पाद का प्रकार / TYPE OF PRODUCT	उत्पाद का नाम / PRODUCT NAME	उत्पाद का कोड / PRODUCT CODE	उत्पाद का वर्ग / PRODUCT CLASS

क्र.सं. / REV.	परिवर्तन / REVISION	दिनांक / DATE	अनुमोदित / APPROVED BY

क्र.सं. / REV.	परिवर्तन / REVISION	दिनांक / DATE	अनुमोदित / APPROVED BY

शुद्धी / TITLE	शुद्धी कोड / TITLE CODE	शुद्धी का नाम / TITLE NAME	शुद्धी का वर्ग / TITLE CLASS

22 03 24
 01

A2 शीट / A2 SIZE

THE INFORMATION ON THIS DOCUMENT IS THE PROPERTY OF BHARAT HEAVY ELECTRICALS LIMITED. IT MUST NOT BE USED DIRECTLY OR INDIRECTLY IN ANY WAY DETERIMENTAL TO THE INTEREST OF THE COMPANY.

90010
 INVENTORY NO. 2-16810
 E

संशोधित अभिकल्प संख्या
 REFERENCE DRG. NO.

हस्ताक्षर और दिनांक/SIGN & DATE
 12-04

प्रथम कोण प्रक्षेपण / FIRST ANGLE PROJECTION
 सभी विमाएँ मिलीमीटर में हैं / ALL DIMENSIONS ARE IN mm.

प्रथम कोणीय 38 (अ) / FORM 38 (A)

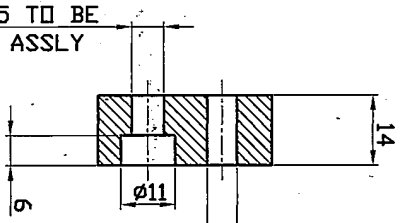
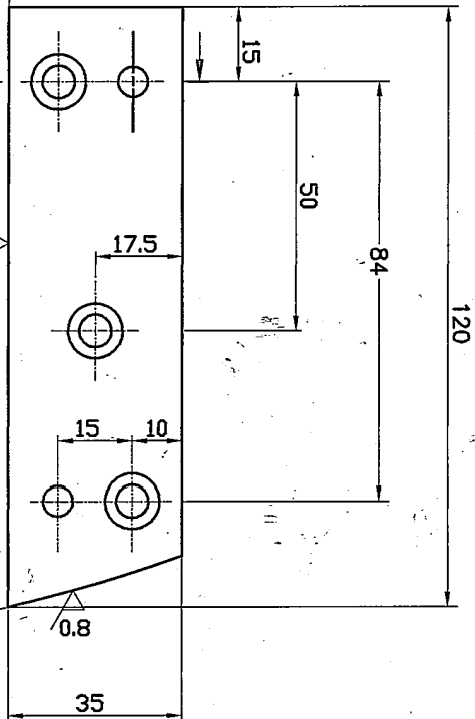

2 HOLES $\phi 6H7(+0.012)$
 TO BE DRILLED IN ASSLY

3 HOLES $\phi 6.5$ TO BE
 DRILLED IN ASSLY

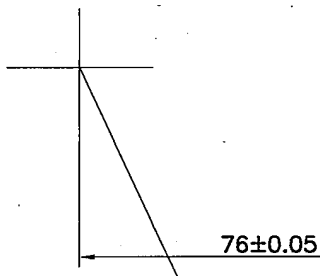

NOTES-

- 1-SHARP EDGES TO BE ROUNDED OFF
- 2-HARDEN TO HRC 50±55 AS PER PS 0912-008
- 3-* TO BE FINALLY GROUND IN ASSLY

HR335-2-0.05

6.3 / THE REST

T55 Si2 Mn90	~0.4	
ASI:S4/IS:3748	1	
MATERIAL CODE	UNIT WEIGHT	
MATERIAL SPECN	QTY	

GRADE OF UNTOL. DIM	
M/CG.- AA0230208 ϕ / μ / μ / μ	
WELDING-CLASS 'B' OF AA0621104	
GAS CUTTING-TABLE 3 OF AA0621101	

श्री.बी.ओ.एस./C.B.O.M.	श्री.के.जी.गो.सं.	श्री.के.जी.गो.सं.
संशोधित अभिकल्प संख्या	श्री.के.जी.गो.सं.	श्री.के.जी.गो.सं.
REV.	DATE	DATE

उत्पाद का प्रकार TYPE OF PRODUCT	भारत हेवी इलेक्ट्रिकल्स लिमिटेड, रानीपुर, हरिद्वार BHARAT HEAVY ELECTRICALS LIMITED, RANIPUR, HARDWAR
श्री.के.जी.गो.सं.	श्री.के.जी.गो.सं.
REV.	DATE

श्री.के.जी.गो.सं.	श्री.के.जी.गो.सं.
REV.	DATE

कार्ड कोड R8381-1719/003	ऑफिस संख्या / DRAWING NO. R8381-1719/003
22 23 24	22 23 24

A3 साइज / A3 SIZE

THIS DRAWING IS THE PROPERTY OF BHARAT HEAVY ELECTRICALS LIMITED. IT MUST NOT BE USED DIRECTLY OR INDIRECTLY IN ANY WAY DETERIMENTAL TO THE INTEREST OF THE COMPANY.

200/61L1-1838R
ON DRAWING/कागज पर

प्रथम कोण प्रक्षेपण/FIRST ANGLE PROJECTION

सभी विमाएँ मिलिमीटर में हैं।/ALL DIMENSIONS ARE IN mm.

प्रथम शीट नं. 38 (अ)/FORM 38 (B)

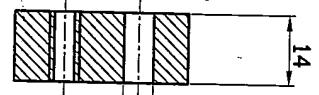
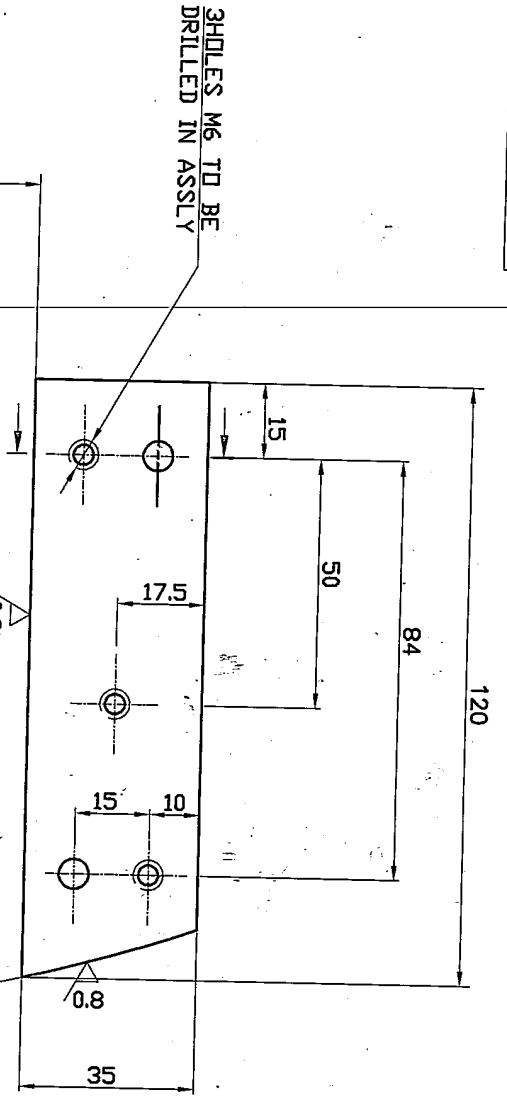

2 HOLES Ø6H7(+0.012)
TO BE DRILLED IN ASSLY

76±0.05

KR3352-005

NOTES-

- 1-SHARP EDGES TO BE ROUNDED OFF
- 2-HARDEN TO HRC 50±55 AS PER PS 0912-008
- 3-* TO BE FINALLY GROUND IN ASSLY

T55 S12 Mn90	~0.4	
AISI:54/IS:3748	1	
MATERIAL CODE	UNIT WEIGHT	
MATERIAL SPECN	QTY	

6.3
THE REST

संशोधित अभिलेख संख्या
REFERENCE DRG. NO.

हस्ताक्षर और दिनांक/SIGN & DATE
21/2/2021

संशोधित अभिलेख संख्या
INVENTORY NO.
2-16810 E

GRADE OF UNTOL. DIM
M/CG- AA0230208 Ø/M/K/F
WELDING-CLASS 'B' OF AA0621104
GAS CUTTING-TABLE 3 OF AA0621101

श्री.श्री.सं./C.B.O.M.	श्री.श्री.सं./C.B.O.M.
अनुमोदित REV.	अनुमोदित REV.
दिनांक DATE	दिनांक DATE
अनुमोदित BY	अनुमोदित BY
श्री.श्री.सं./C.B.O.M.	श्री.श्री.सं./C.B.O.M.
अनुमोदित REV.	अनुमोदित REV.
दिनांक DATE	दिनांक DATE
अनुमोदित BY	अनुमोदित BY

उत्पाद का प्रकार
TYPE OF PRODUCT
भारत हेवी इलेक्ट्रिकल्स लिमिटेड, रांणपुर, हरियाणा
BHARAT HEAVY ELECTRICALS LIMITED,
RANIPUR, HARYANWAR

श्री.श्री.सं./C.B.O.M.
अनुमोदित
REV.
दिनांक
DATE
अनुमोदित
BY
श्री.श्री.सं./C.B.O.M.

श्री.श्री.सं./C.B.O.M.
अनुमोदित
REV.
दिनांक
DATE
अनुमोदित
BY
श्री.श्री.सं./C.B.O.M.

श्री.श्री.सं./C.B.O.M.
अनुमोदित
REV.
दिनांक
DATE
अनुमोदित
BY
श्री.श्री.सं./C.B.O.M.

श्री.श्री.सं./C.B.O.M.
अनुमोदित
REV.
दिनांक
DATE
अनुमोदित
BY
श्री.श्री.सं./C.B.O.M.

श्री.श्री.सं./C.B.O.M.
अनुमोदित
REV.
दिनांक
DATE
अनुमोदित
BY
श्री.श्री.सं./C.B.O.M.

श्री.श्री.सं./C.B.O.M.
अनुमोदित
REV.
दिनांक
DATE
अनुमोदित
BY
श्री.श्री.सं./C.B.O.M.

A3 तांबड़ा/A3 SIZE

2-16810

संशुद्धी सूची संख्या/INVENTORY NO. 2-16810
 प्रोडक्ट नाम/SON & DATE 1/2/2009
 संदर्भ संकेत संख्या/REFERENCE DRG. NO.

COPYRIGHT AND CONFIDENTIAL
 THE INFORMATION ON THIS DOCUMENT IS THE PROPERTY OF BHARAT HEAVY ELECTRICALS LIMITED.
 IT MUST NOT BE USED DIRECTLY OR INDIRECTLY IN ANY WAY DETERIMENTAL TO THE INTEREST OF THE COMPANY

100/19/11-18381
 प्रथम कोण प्रक्षेपण/FIRST ANGLE PROJECTION
 सभी कोण प्रक्षेपण में सभी L/ALL DIMENSIONS ARE IN mm.
 6.3 / THE REST

- NOTES-
- 1-SHARP EDGES TO BE ROUNDED OFF
 - 2-HARDEN TO HRC 50-55 AS PER PS 0912-008
 - 3-# TO BE FINALLY GROUND IN ASSLY

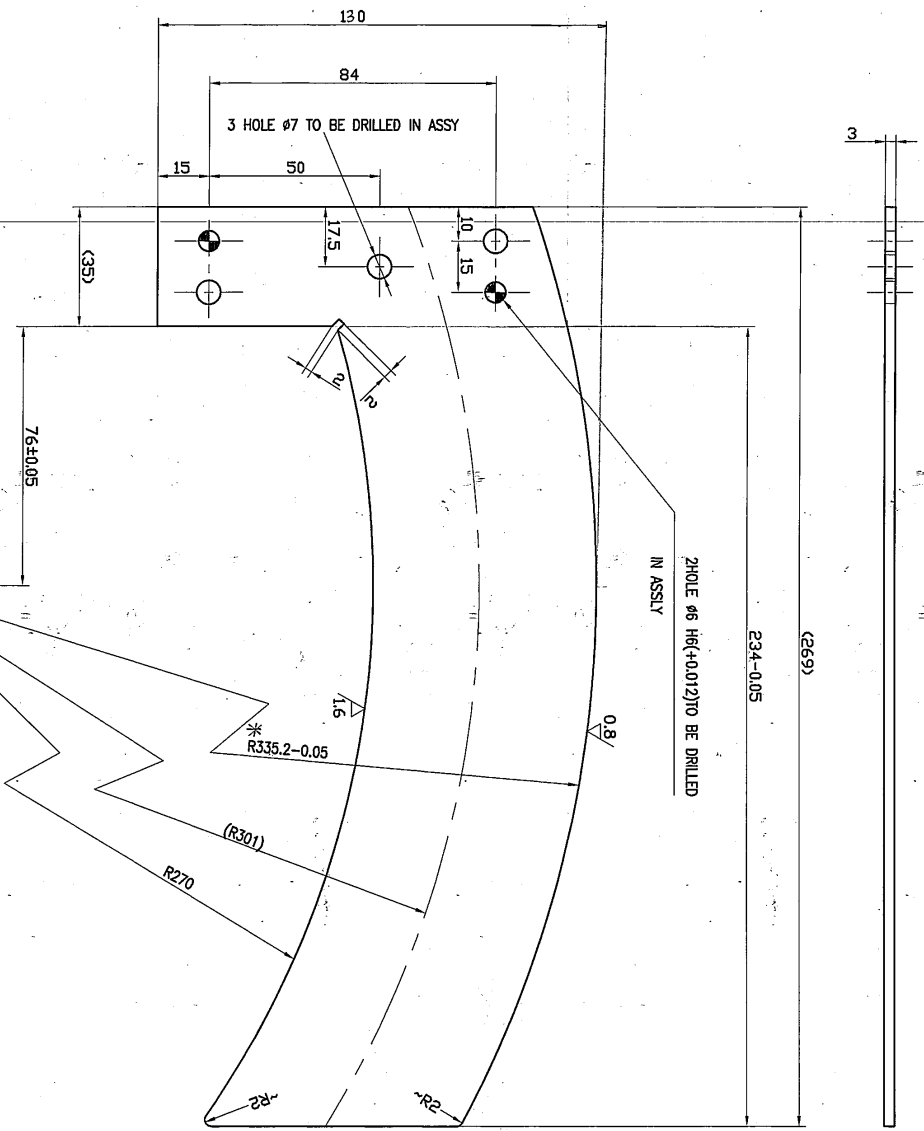

GRADE OF INTOL. DIM	W/CG - AA0230208 E/M/K/K
WELDING-CLASS 'B' OF AA0621104	
CNS CUTTING-TABLE 3 OF AA0621101	
REV	REVISION

आपत्कृत संख्या/CAE O.M.	आपत्कृत संख्या/CAE O.M.
आपत्कृत संख्या/CAE O.M.	आपत्कृत संख्या/CAE O.M.
आपत्कृत संख्या/CAE O.M.	आपत्कृत संख्या/CAE O.M.
आपत्कृत संख्या/CAE O.M.	आपत्कृत संख्या/CAE O.M.

उत्पाद का प्रकार TYPE OF PRODUCT	उत्पाद का प्रकार TYPE OF PRODUCT
उत्पाद का प्रकार TYPE OF PRODUCT	उत्पाद का प्रकार TYPE OF PRODUCT
उत्पाद का प्रकार TYPE OF PRODUCT	उत्पाद का प्रकार TYPE OF PRODUCT
उत्पाद का प्रकार TYPE OF PRODUCT	उत्पाद का प्रकार TYPE OF PRODUCT

आपत्कृत संख्या/CAE O.M.	आपत्कृत संख्या/CAE O.M.
आपत्कृत संख्या/CAE O.M.	आपत्कृत संख्या/CAE O.M.
आपत्कृत संख्या/CAE O.M.	आपत्कृत संख्या/CAE O.M.
आपत्कृत संख्या/CAE O.M.	आपत्कृत संख्या/CAE O.M.

190M6HC2
 HW10892
 MATERIAL

A2 आकार/A2 SIZE

COPYRIGHT AND CONFIDENTIAL
 THE INFORMATION ON THIS DOCUMENT IS THE PROPERTY OF BHARAT HEAVY ELECTRICALS LIMITED.
 IT MUST NOT BE USED DIRECTLY OR INDIRECTLY IN ANY WAY DETERIMENTAL TO THE INTEREST OF THE COMPANY

संशोधन संख्या / INVENTORY NO. 2-1688/c
 एकांक संख्या / DRAWING NO. K.R. 100
 संदर्भ संख्या / REFERENCE DRG. NO.

6111-1688R

OR SURFACE/दिशा संकेत

प्रथम कोण प्रक्षेपण / FIRST ANGLE PROJECTION

सभी मापन आकारों में ही / ALL DIMENSIONS ARE IN mm.

2

पृष्ठ संख्या (49) / 50

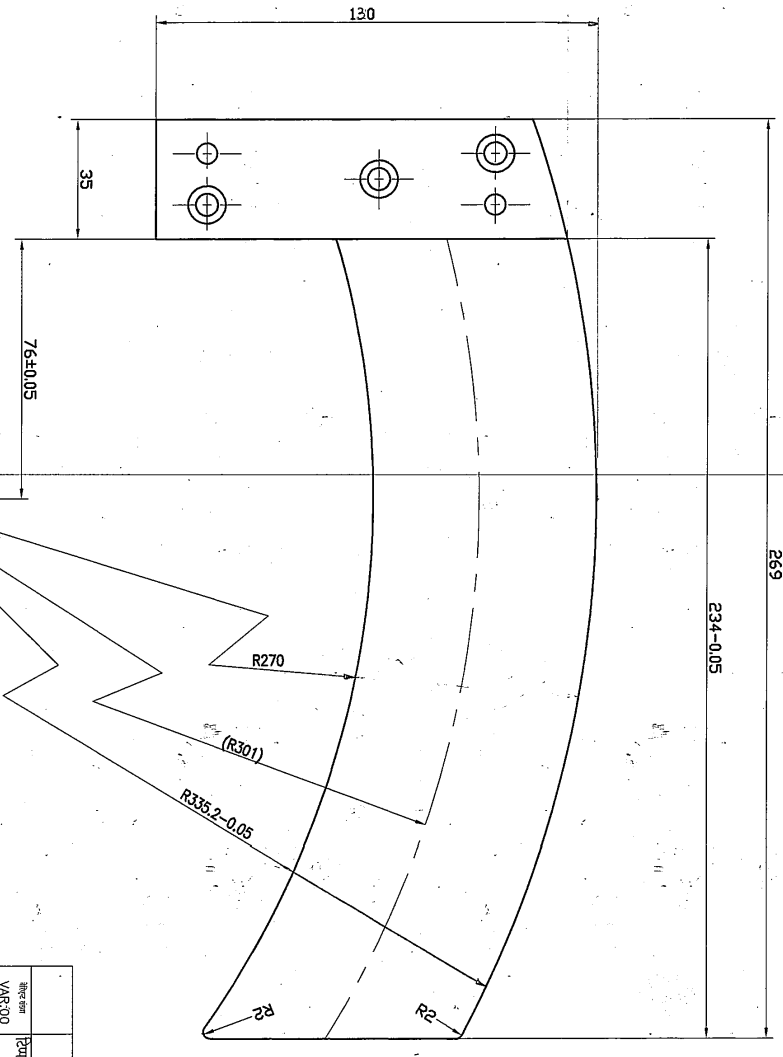
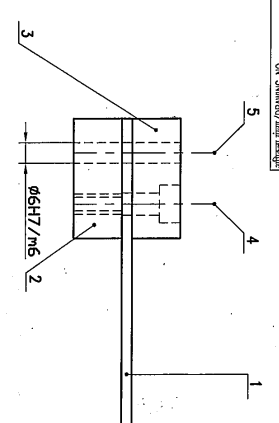

MARK
 R8381-1719
 FORM 17(250 MM)

क्र. सं.	वस्तु का विवरण / REMARKS	मापन संख्या / DIM. NO.	संशोधन संख्या / REV.	विवरण / DESCRIPTION	मापन संख्या / DIM. NO.	संशोधन संख्या / REV.	विवरण / DESCRIPTION	मापन संख्या / DIM. NO.	संशोधन संख्या / REV.	विवरण / DESCRIPTION
01	PLATE			PLATE LOWER						
02	PLATE UPPER			PLATE UPPER						
03	SCRU CAP SOC PM 6x25			SCRU CAP SOC PM 6x25						
04	PN CIL RND 66m 6x30			PN CIL RND 66m 6x30						

वस्तु का नाम / NAME	वस्तु का आकार / SIZE	वस्तु का सामग्री / MATERIAL	वस्तु का भार / WEIGHT	वस्तु का आकार / SIZE	वस्तु का सामग्री / MATERIAL	वस्तु का भार / WEIGHT
ST 250 MW	1:1	STEEL 12.9	~1.26	AA 7123123-042	AA 7123123	~0.007
TYPE OF PRODUCT	SCALE	AA 7123123-042	~1.26	AA 7123123	AA 7123123	~0.007
ST 250 MW	1:1	AA 7123123-042	~1.26	AA 7123123	AA 7123123	~0.007
TYPE OF PRODUCT	SCALE	AA 7123123-042	~1.26	AA 7123123	AA 7123123	~0.007
ST 250 MW	1:1	AA 7123123-042	~1.26	AA 7123123	AA 7123123	~0.007

वस्तु का नाम / NAME	वस्तु का आकार / SIZE	वस्तु का सामग्री / MATERIAL	वस्तु का भार / WEIGHT	वस्तु का आकार / SIZE	वस्तु का सामग्री / MATERIAL	वस्तु का भार / WEIGHT
ST 250 MW	1:1	AA 7123123-042	~1.26	AA 7123123	AA 7123123	~0.007
TYPE OF PRODUCT	SCALE	AA 7123123-042	~1.26	AA 7123123	AA 7123123	~0.007
ST 250 MW	1:1	AA 7123123-042	~1.26	AA 7123123	AA 7123123	~0.007
TYPE OF PRODUCT	SCALE	AA 7123123-042	~1.26	AA 7123123	AA 7123123	~0.007
ST 250 MW	1:1	AA 7123123-042	~1.26	AA 7123123	AA 7123123	~0.007

संशोधन संख्या / INVENTORY NO. 2-1688/c
 एकांक संख्या / DRAWING NO. K.R. 100
 संदर्भ संख्या / REFERENCE DRG. NO.

वस्तु का नाम / NAME
 वस्तु का आकार / SIZE
 वस्तु का सामग्री / MATERIAL
 वस्तु का भार / WEIGHT

वस्तु का नाम / NAME
 वस्तु का आकार / SIZE
 वस्तु का सामग्री / MATERIAL
 वस्तु का भार / WEIGHT

6071-1838R
NON DIMW/DWG/संकेत संख्या

प्रथम कोण प्रक्षेपण / FIRST ANGLE PROJECTION

सभी विमाएँ मिलीमीटर में हैं / ALL DIMENSIONS ARE IN mm.

पत्र सं. 38 (क)/FORM 38 (B)

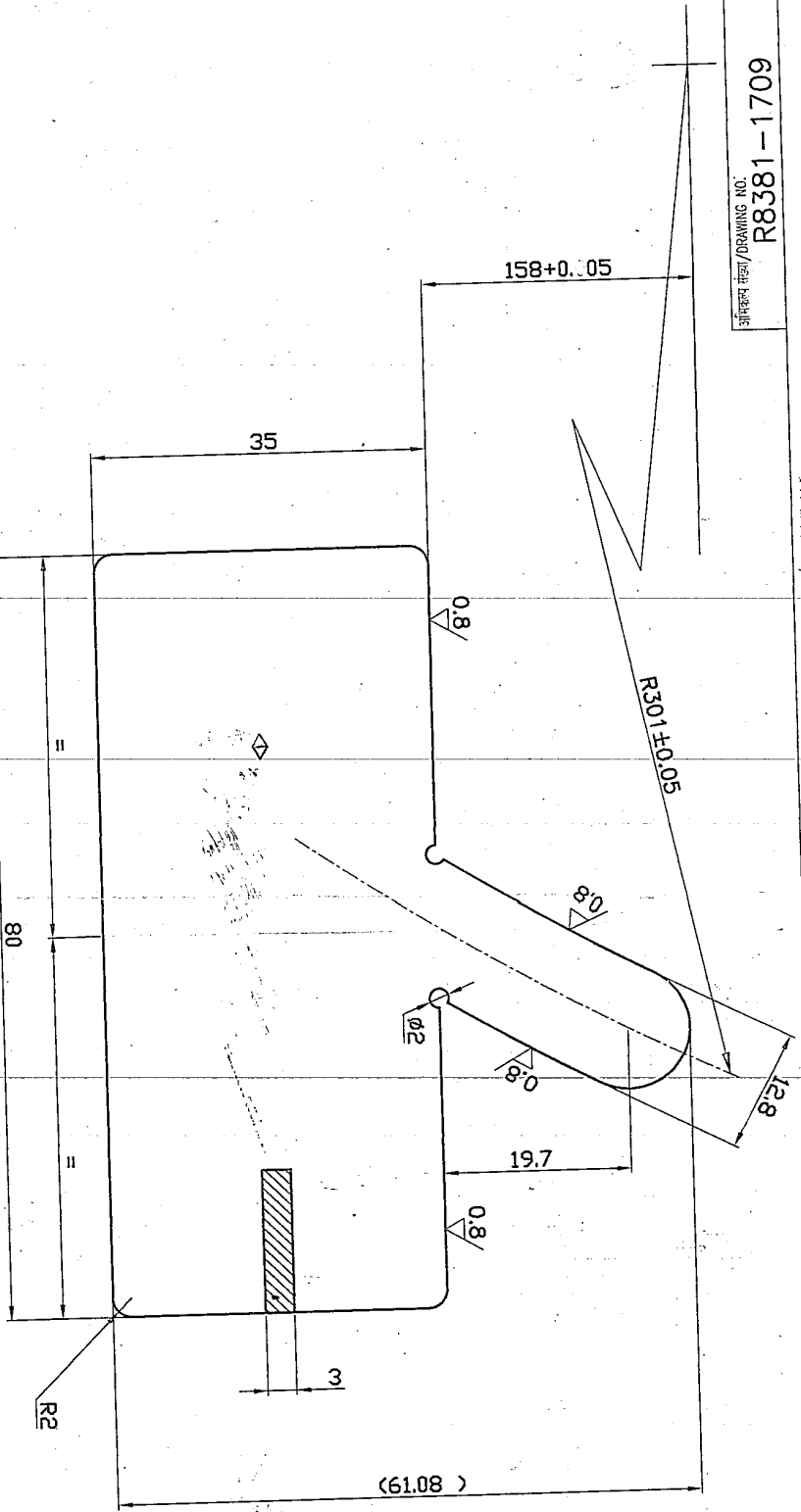

MARK
R3381-1709
R301, 12.8



NOTES-

- 1-SHARP EDGES TO BE ROUNDED OFF.
- 2-HARDEN TO HRC 55-60 AS PER PS 0912-008
- 3-CONSERVATION TO BE DONE AS PER TL 30007

क्र. सं. / C.B.O.M.	विवरण	विवरण	क्रमांक और संख्या / COMP DRG. No.	संशोधन संख्या / M/c No.	संशोधन संख्या / REF DRG. No.
VAR.00	REMARKS	DESCRIPTION	01039746032 01030746033		R3381-1620
TYPE OF PRODUCT	ST 250 MW	अनुपात / SCALE	2:1	भारत हेवी इलेक्ट्रिकल्स लिमिटेड, रामपुर, बिहार	
भारत हेवी इलेक्ट्रिकल्स लिमिटेड, रामपुर, बिहार	BHARAT HEAVY ELECTRICALS LIMITED, RAMPUR, HARDWAR	भारत के. आ. अतिरिक्त का संदर्भ	REFER TO ASSLY. DRG.		

GRADE OF UNTOL. DIM	M/CG.- AA0230208 Ø/M/L
WELDING-CLASS 'B' OF AA0621104	
GAS CUTTING-TABLE 3 OF AA0621101	
REV	DATE

संशोधन संख्या / C.B.O.M.	संशोधन संख्या / M/C No.	संशोधन संख्या / REF DRG. No.
ST	G.SINGH	22/3/24
APPROVED DESIG.	DATE	

संशोधन संख्या / C.B.O.M.	संशोधन संख्या / M/C No.	संशोधन संख्या / REF DRG. No.
REV	DATE	
भारत हेवी इलेक्ट्रिकल्स लिमिटेड, रामपुर, बिहार	BHARAT HEAVY ELECTRICALS LIMITED, RAMPUR, HARDWAR	
अनुपात / SCALE	2:1	
भारत के. आ. अतिरिक्त का संदर्भ	REFER TO ASSLY. DRG.	

शीर्षक / TITLE	कार्ड कोड	पृष्ठ सं. / Sheet No.	पृष्ठों की संख्या / No. of Sheets
LOCKING PIECE GROOVE TEMPLATE(RH)	R8381-1709	01	01
			22.23.24

3-19025-110 2/1/10

सामग्री सूची संख्या / INVENTORY NO. 11

संशोधन और दिनांक / SIGN & DATE

संदर्भित अभिकल्प संख्या / REFERENCE DRG. NO.

A3 सं. 38 / A3 SIZE

