

GENERAL NOTES:
 1. ALL DIMENSIONS ARE IN "mm" UNLESS SPECIFIED.
 2. DO NOT SCALE THE DRAWING. IF IN DOUBT ASK.
 3. WELDING SYMBOLS AS PER IS: 813
 4. ALLOWABLE DEVIATIONS FOR DIMENS : WITHOUT SPECIFIED TOLERANCES FOLLOW IS: 2102/1898.

SIZE: _____ SHEET: _____ OF _____

DRAWING NO. **S P D B M D A 4 2 6 4 6**

REV. _____

TITLE: **BULL RING SEGMENTS ARRANGEMENT FOR XRP-1008 BOWL MILL**

DESIGNED	PROJN.	⊕
DRAWN	DATE	17/4/14
CHECKED	SCALE	NTS
APPROVED	DEPT.	O&M Ptg.

RIHAND SUPER THERMAL POWER PROJECT **NTPC**
 (A GOVERNMENT OF INDIA ENTERPRISE)

This drawing is only tender purpose.

PARTS LIST				
PART No.	DESCRIPTION	QTY.	MATERIAL	UNIT WT. IN K.G.

NOTE: For details of bull ring segments ref. drawings: SPD/BMD/A3/GA7 & GA9

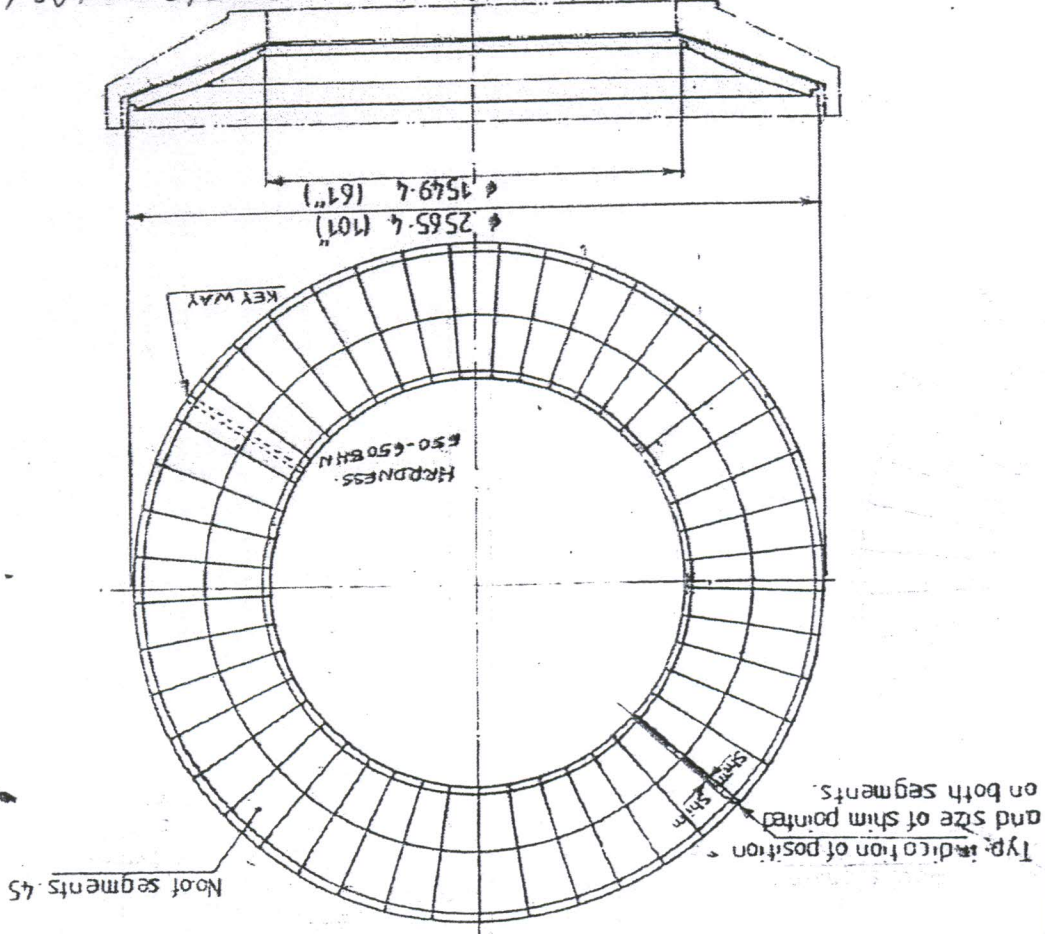

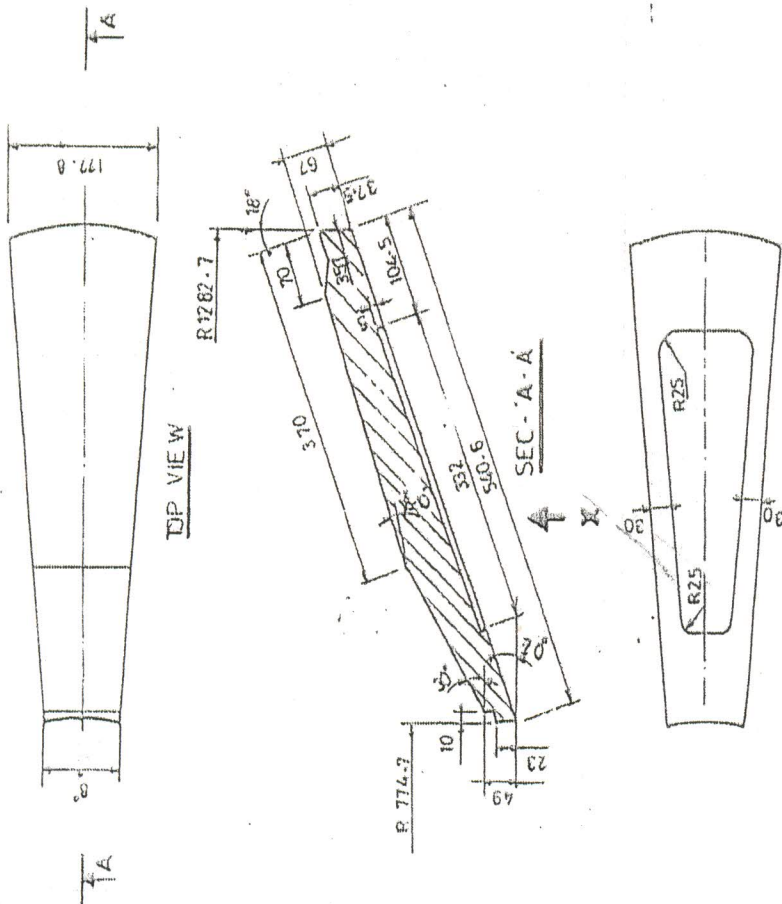

NOTE:- Bottom and side faces to be suitably hand ground.

PART NO.	DESCRIPTION	QTY.	MATERIAL	MARKING	REMARKS
01	Bull Ring Segment	44	MS	35-0	

PARTS LIST

This drawing is only tender purpose.

RIHAND SUPER THERMAL POWER PROJECT
(A GOVERNMENT OF INDIA ENTERPRISE)

REV.

1	2	3	4	5	6	7
S	P	D	B	M	D	A

 26497

DRAWING NO.

S	P	D	B	M	D	A
---	---	---	---	---	---	---

 26497

SHEET

1	2	3	4	5	6	7
---	---	---	---	---	---	---

 OF

1	2	3	4	5	6	7
---	---	---	---	---	---	---

DESIGNED	PROJIN	DATE	SCALE	DEPT.
DRAWN	17/01/10	17/01/10	NTS	BMD
CHECKED				
APPROVED				

GENERAL NOTES
 1 ALL DIMENSIONS ARE IN MM UNLESS SPECIFIED OTHERWISE
 2 DIMENSIONS IN PARENTHESIS ARE FOR REFERENCE ONLY
 3 DIMENSIONS IN SQUARE SYMBOLS ARE PER IS 1031
 4 ALLOWABLE DEVIATIONS FOR DIMENSIONS WITH TOLERANCES FOLLOW IS 1031

SYMBOLS USED TO DENOTE SURFACE ROUGHNESS	OLD METHOD	NEW METHOD	REFERENCE ORIENTATIONS
			1 2 3

GENERAL TOLERANCES FOR DIMENSIONS UNLESS OTHERWISE STATED:
 0 - 100 0.2
 101 - 200 0.3
 201 - 400 0.4
 401 - 600 0.5
 601 - 1000 0.75
 1001 - 2000 1.0
 ABOVE 2000 1.5 STATED

ADDITIONAL INFORMATION
 PREPARED BY: _____ DATE: _____
 CHECKED BY: _____ DATE: _____
 APPROVED BY: _____ DATE: _____