

SECTION L-L SHEET-1

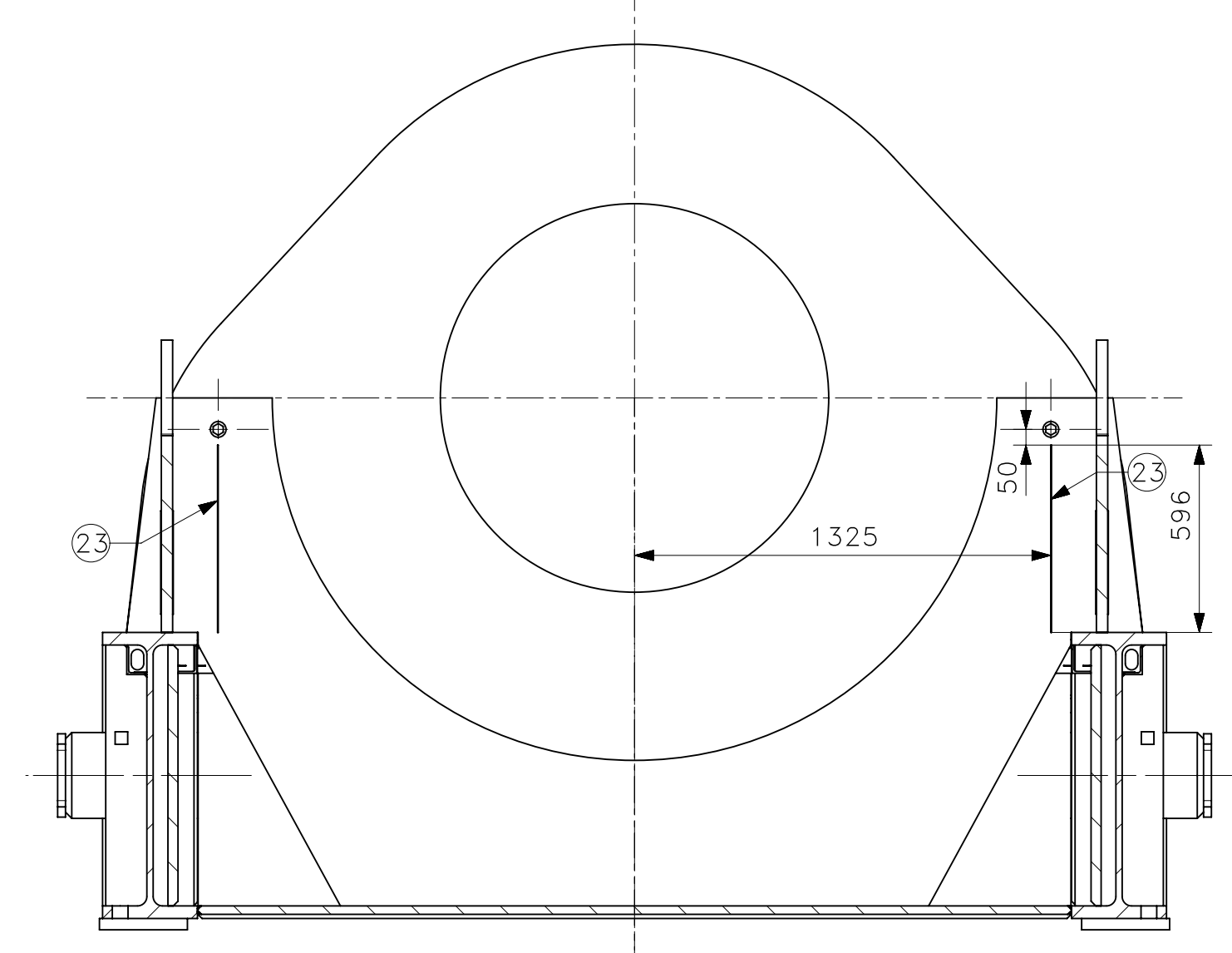

SECTION AE-AE SHEET-1

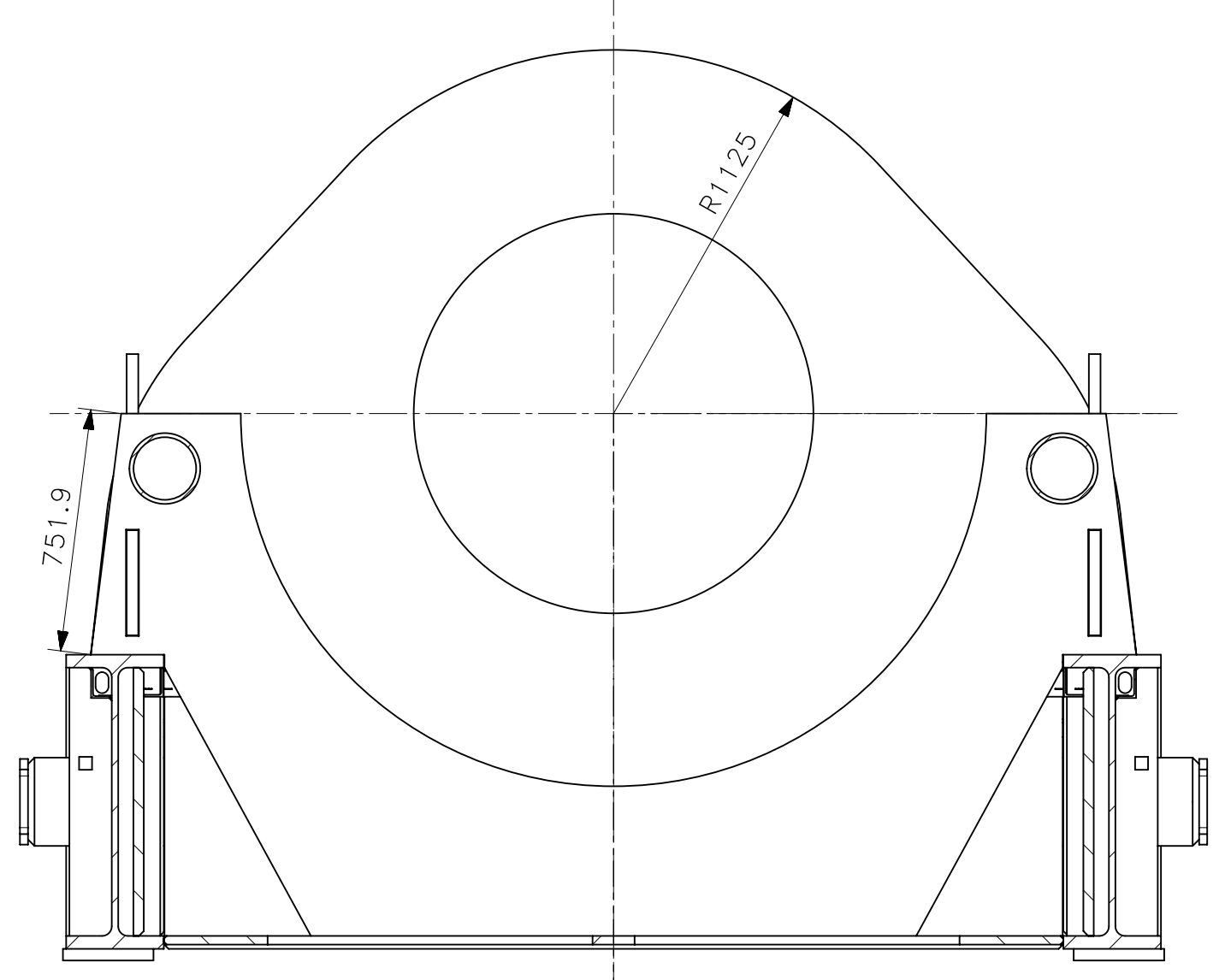

SECTION N-N SHEET-1

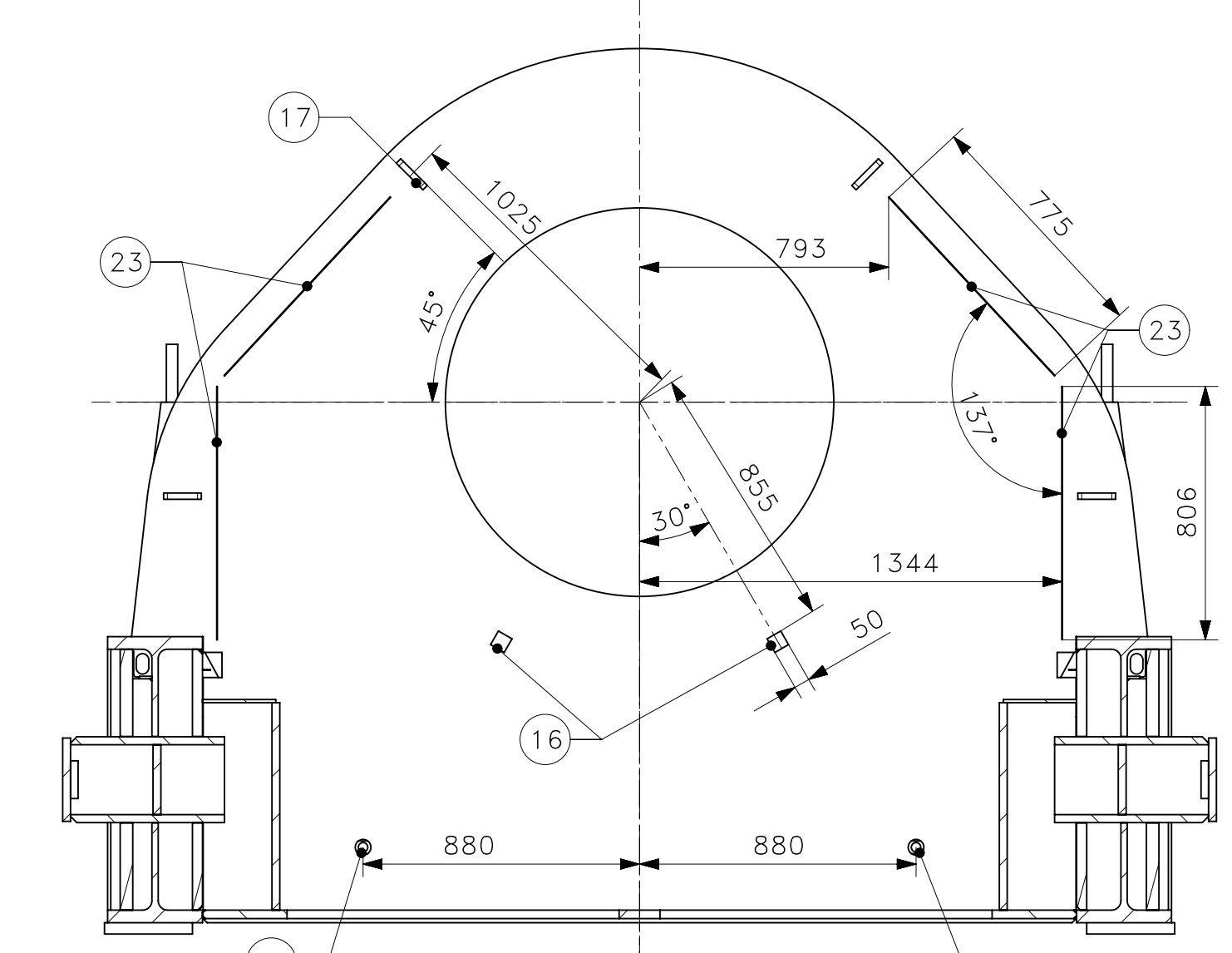

SECTION M-M SHEET-1

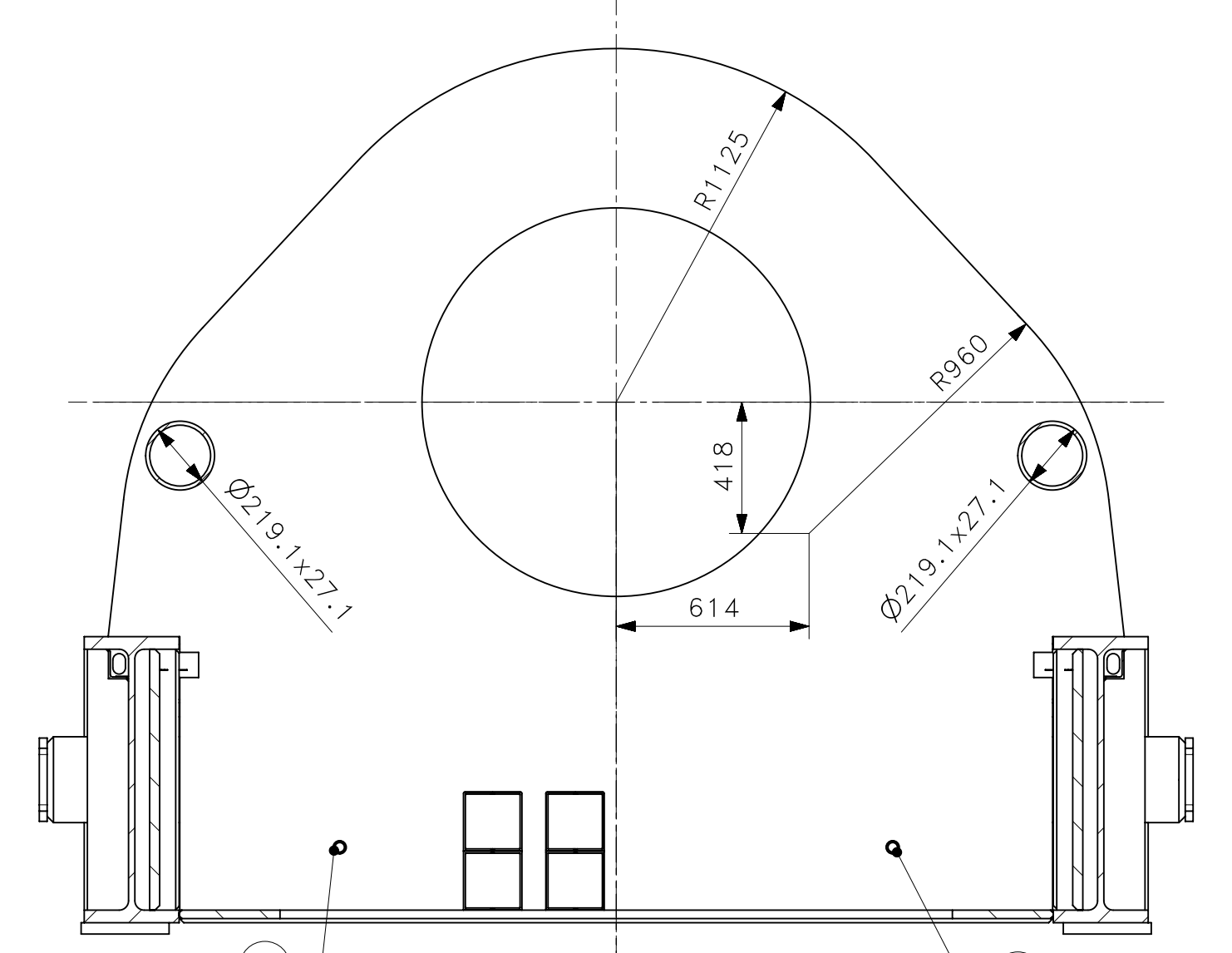

SECTION P-P SHEET-1

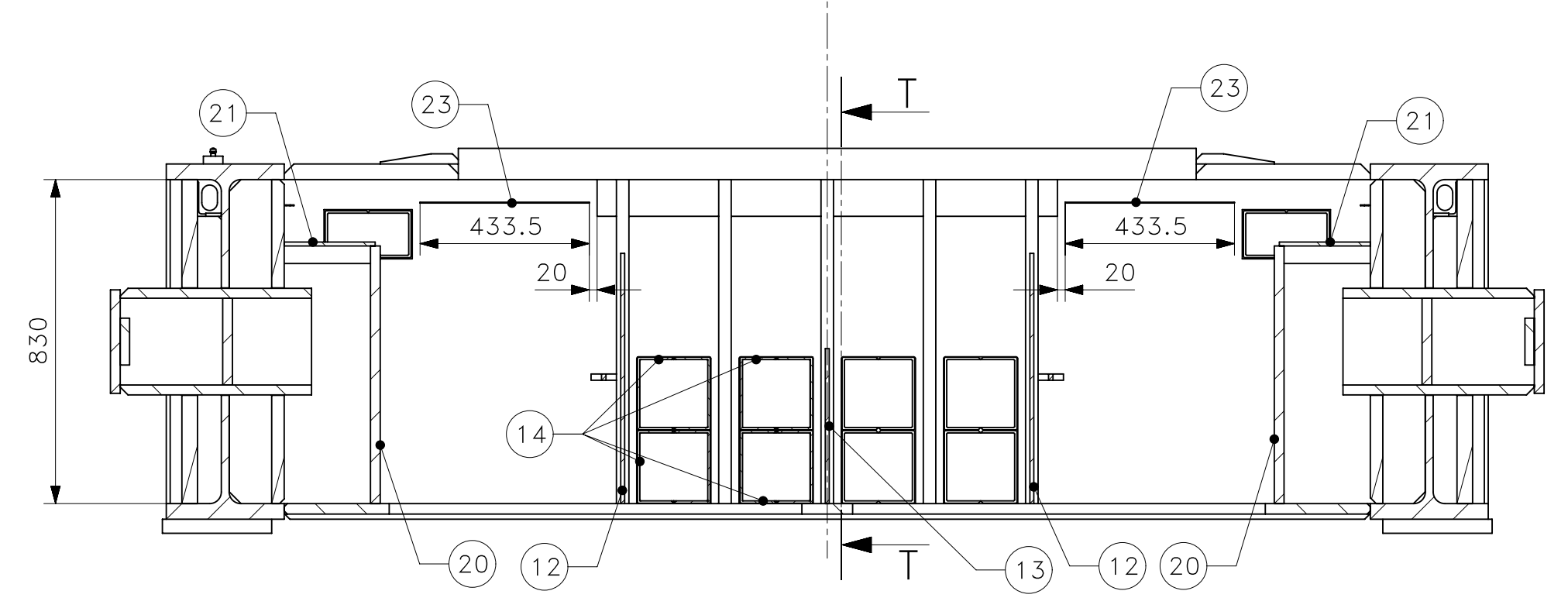

SECTION K-K

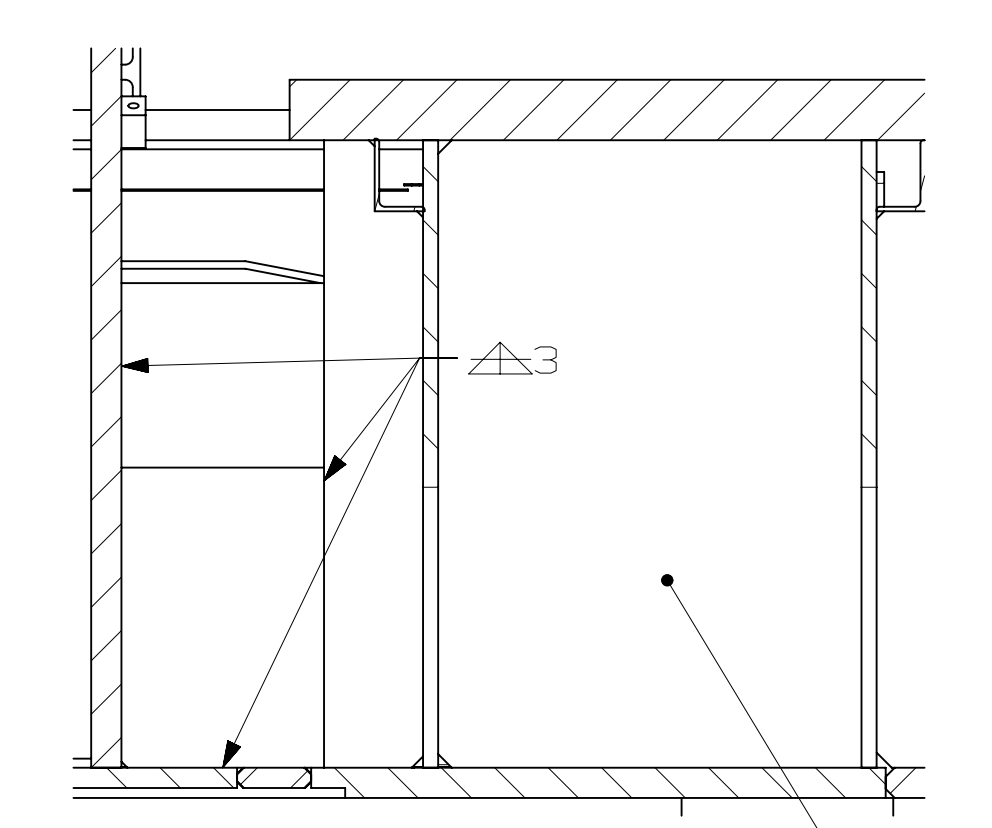

SECTION T-T

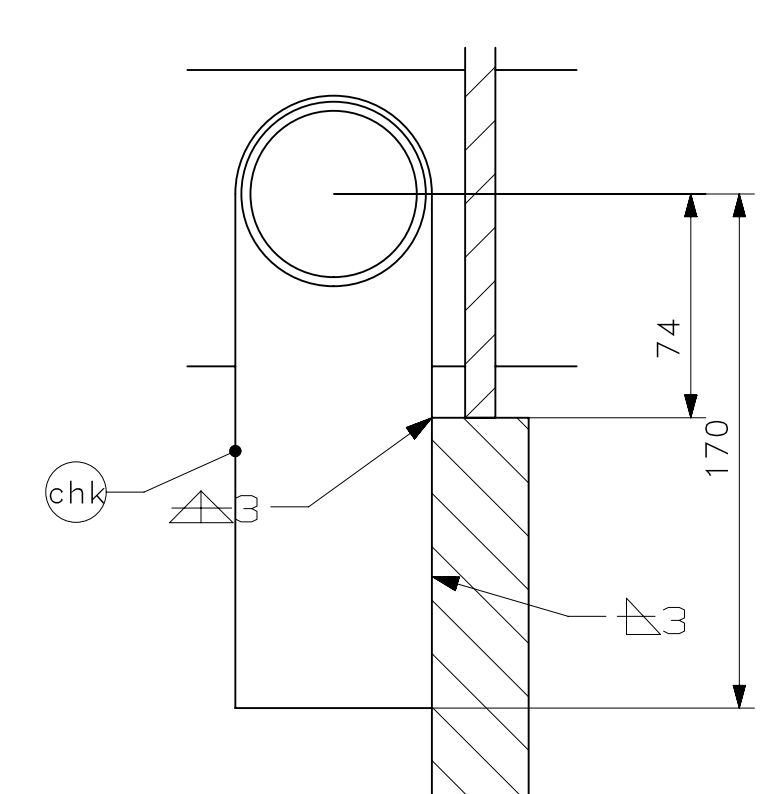

SECTION R-R

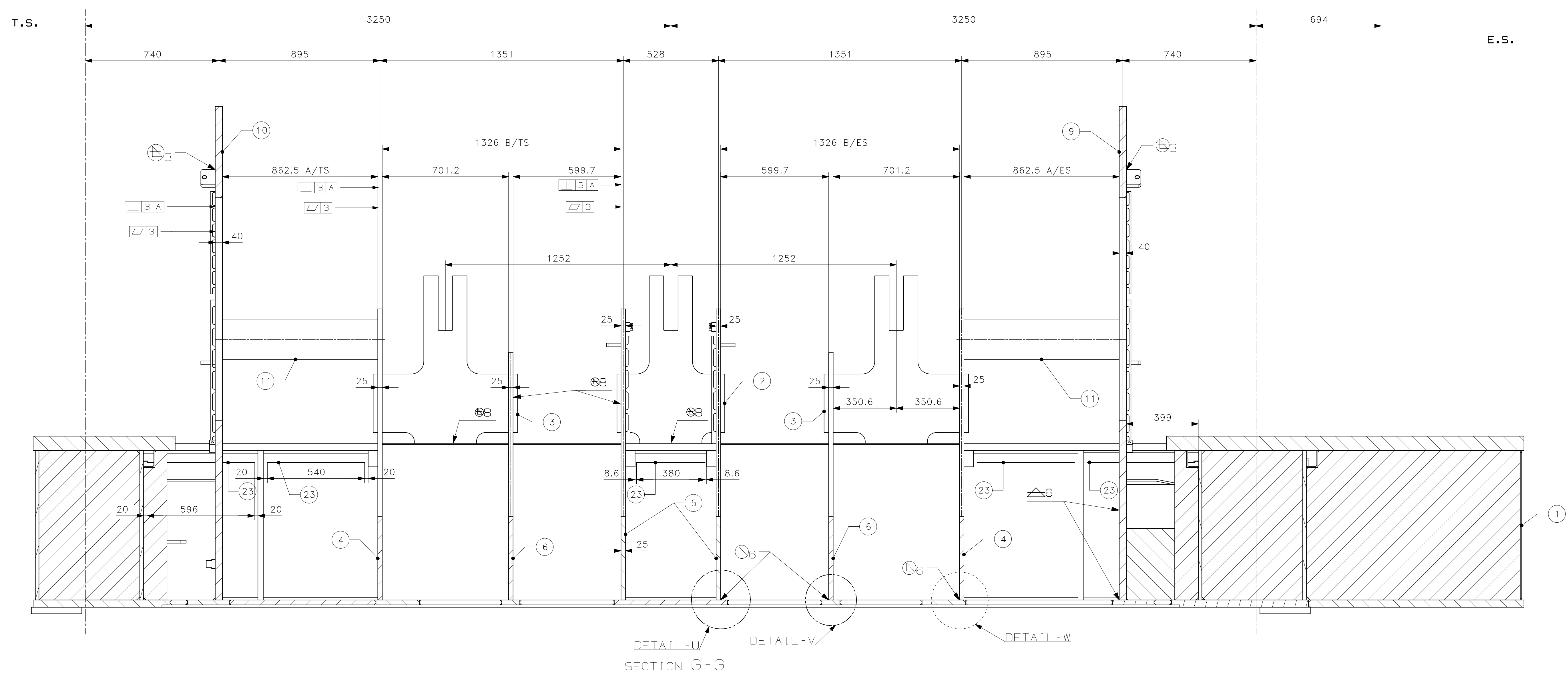
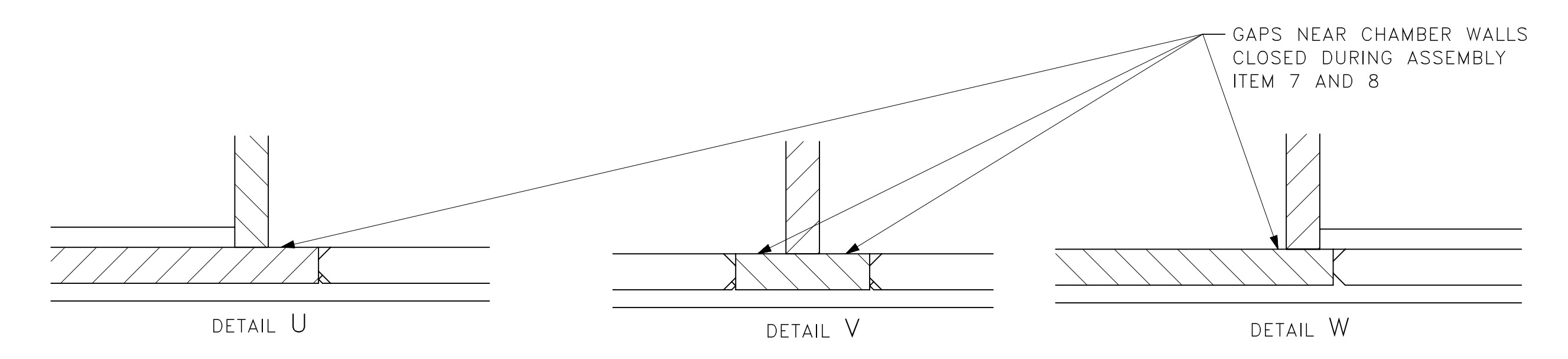

SECTION G-G

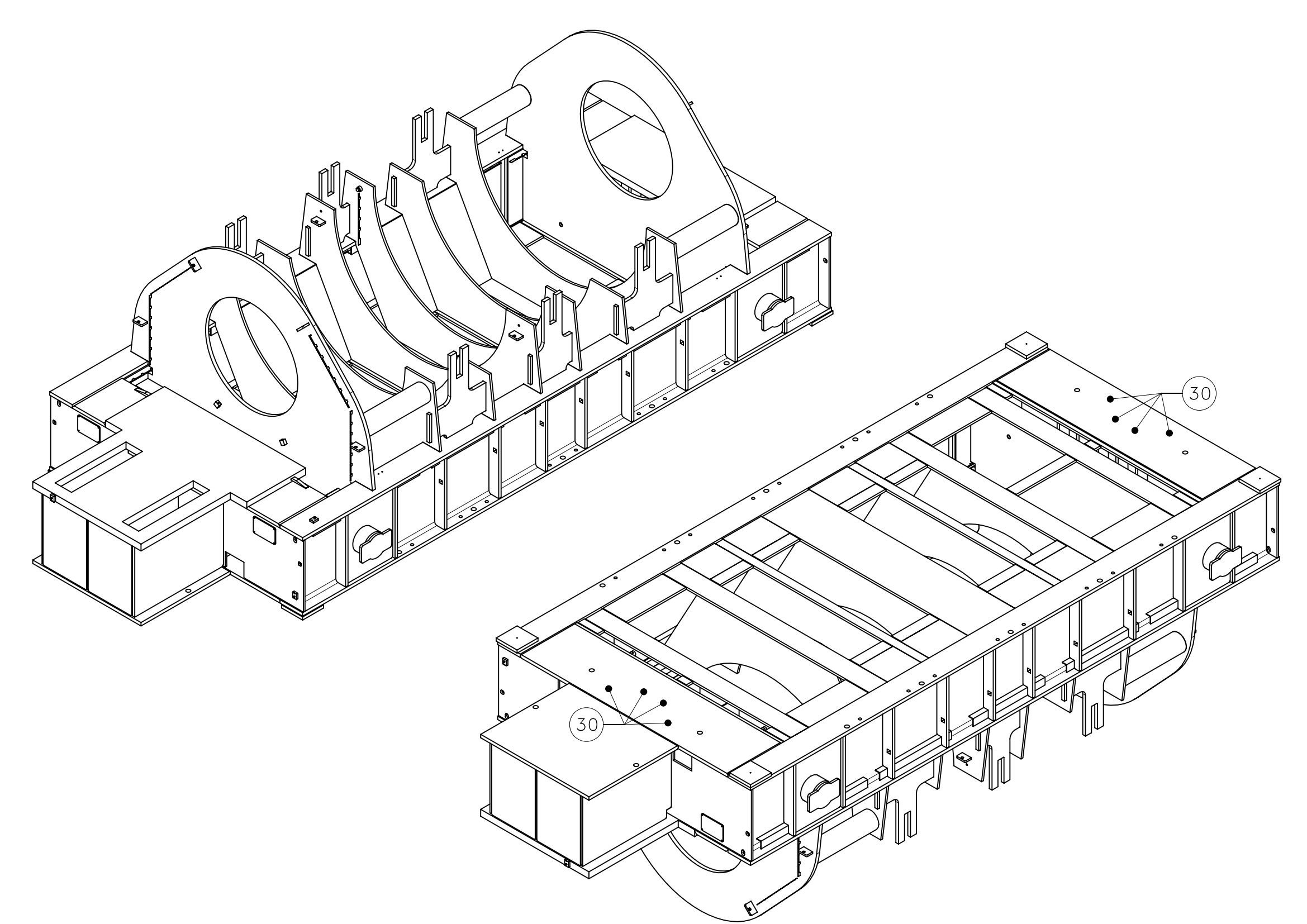

NOTE: ALL BUT WELDS WITH PARTIAL PENETRATION JOINT ARE TO BE CARRIED OUT AS PER THE DRG. AND NOT REQUIRED TO CARRYOUT "UT" TEST.

NA				27050	
ITEM NO.	DESCRIPTION	DRAWING NO.	W/L NO.	RAW MATERIAL SIZE OR CASTING DRG. NO. OR FORGING DRG. NO.	MATERIAL CODE
					NET WT.
					GROSS WT.
					QUANTITY

THE FOLLOWING CONDITIONS APPLY EXCEPT OTHERWISE STATED.....

- REF. TO HWS2008) FOR UNSPECIFIED TOLERANCES.
- CHAMFER W/C/D. SHARP EDGES 1:2 AT 45°.
- INTERNAL W/C/D. CORNER RADI 1 TO 0.7
- THE SURFACE ROUGHNESS WHEREVER NOT SHOWN SHALL BE TAKEN FROM THE SURFACE ROUGHNESS SHOWN OUT SIDE BACK SLASHES GIVEN AT THE TOP MOST RIGHT CORNER OF THE DRG.

TYPE OF PRODUCT	NAME OF CUSTOMER/PROJECT	NAME	DATE	NO. OF V/S.
DEPT. CODE	INTL. DRG. OR C/M/F	SCALE	HEIGHT (MM)	REF. TO ASSY DRG.
425		NTS	27050	01350131212
TITLE	STATOR FRAME WELDMENT	DRAWING NO.	0-135-01-31205	REV.
	BOTTOM PART	SHEET NO.	02	NO. OF SHEETS 02

THE INFORMATION ON THIS DOCUMENT IS THE PROPERTY OF BHARAT HEAVY ELECTRICALS LIMITED. IT MUST NOT BE USED DIRECTLY OR INDIRECTLY IN ANY WAY DETRIMENTAL TO THE INTEREST OF THE COMPANY.

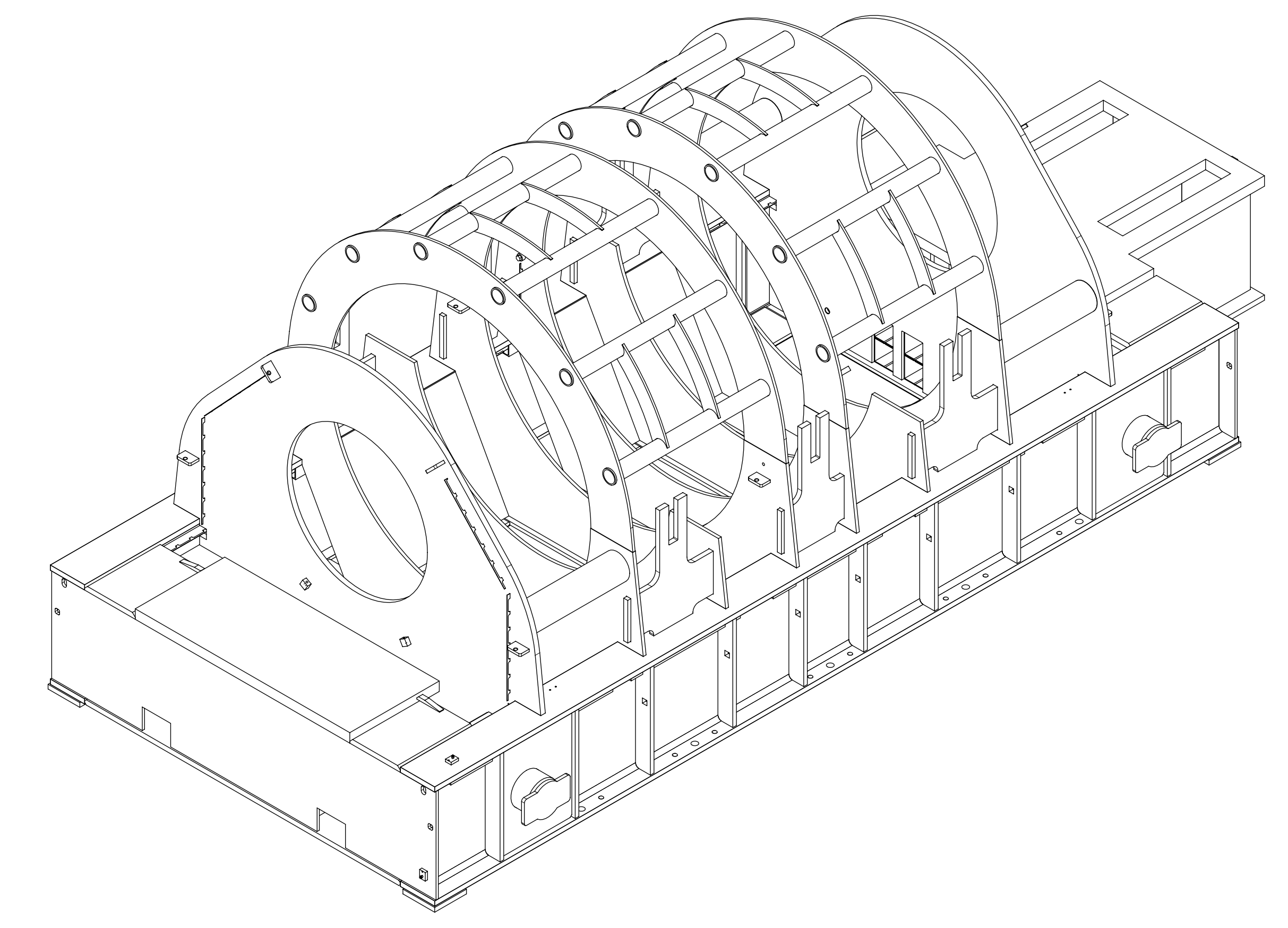
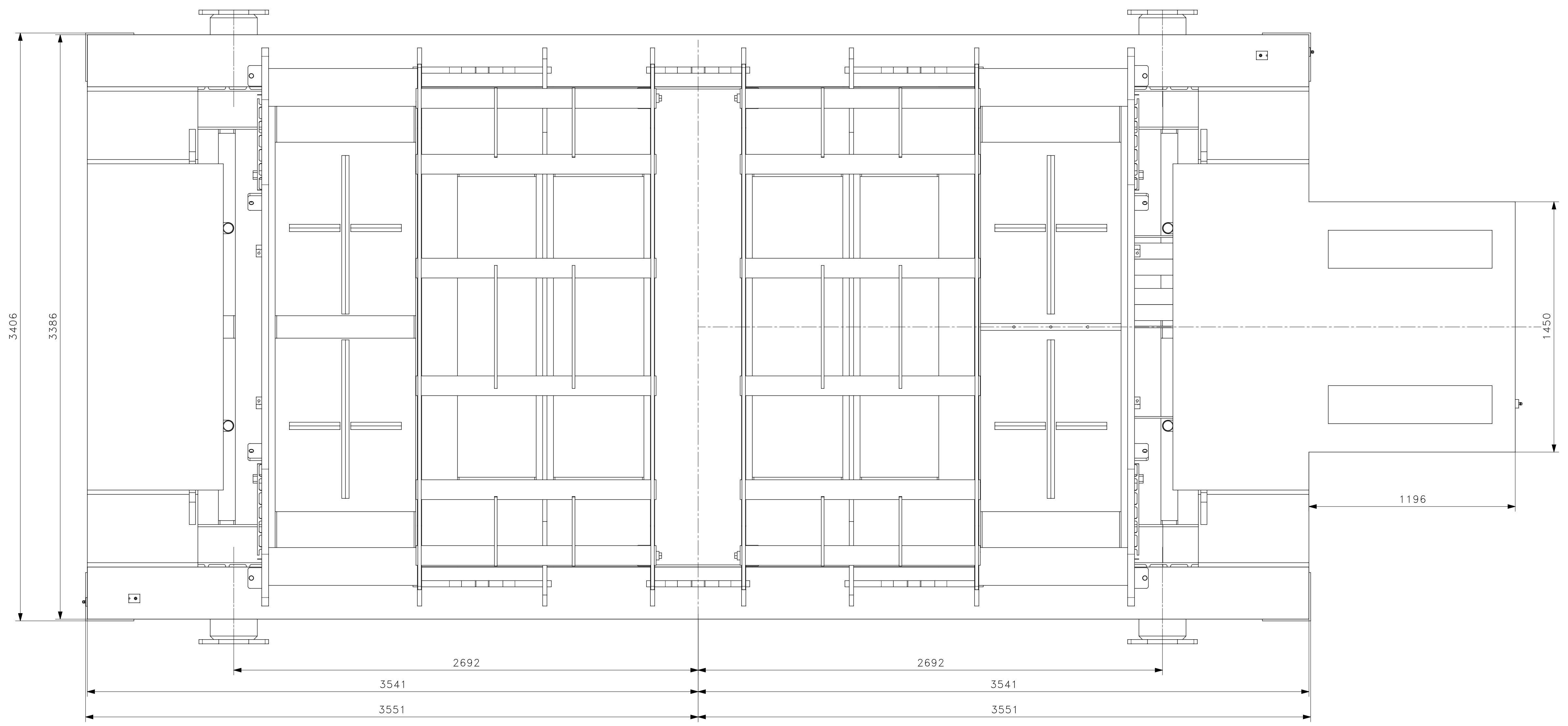
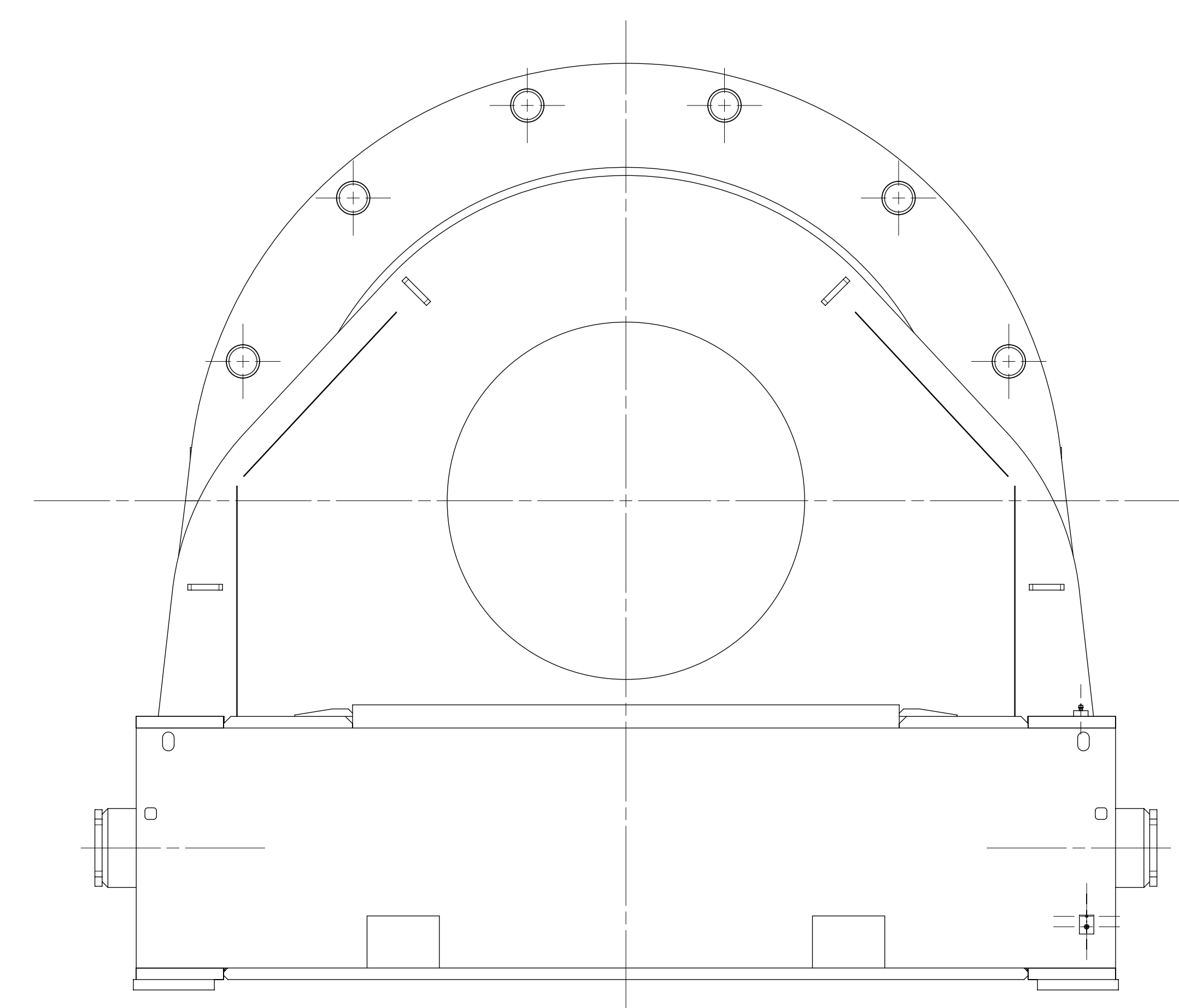
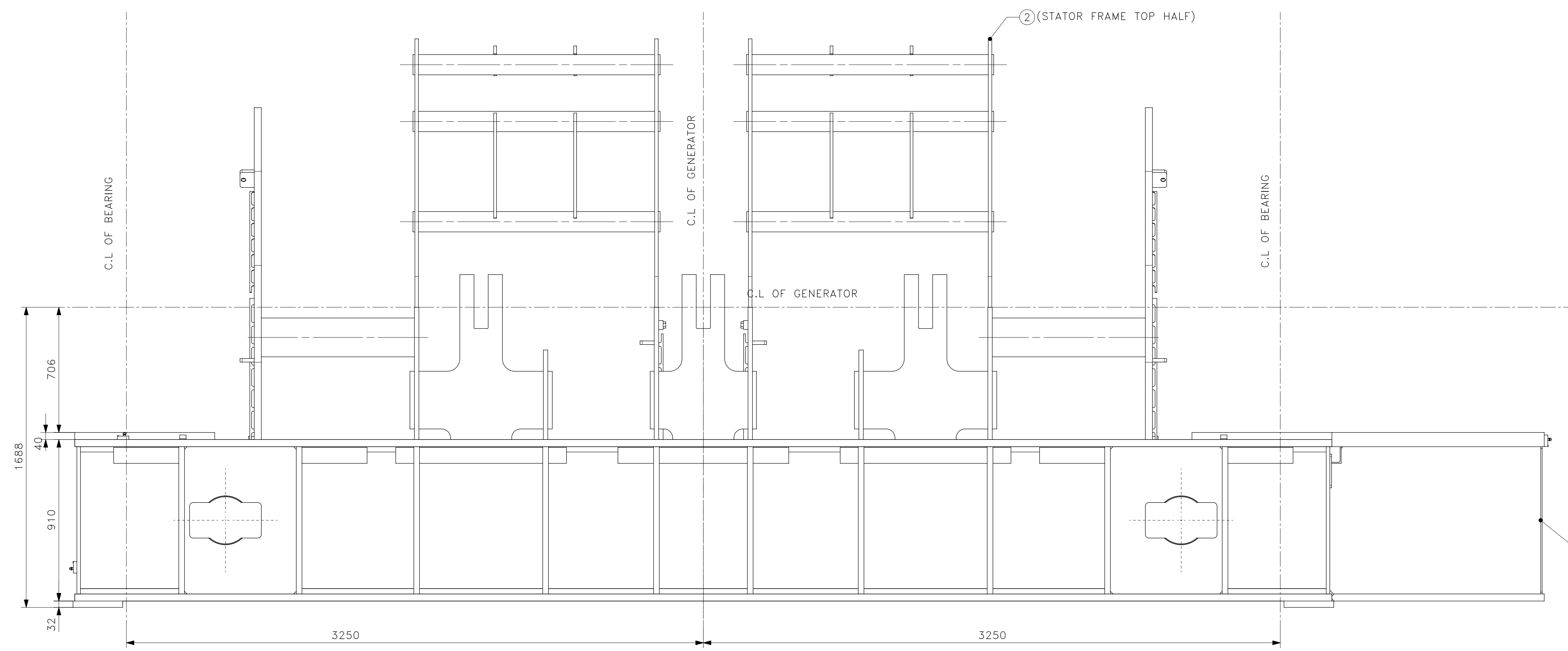

PAINT:

1. UNLESS OTHERWISE SPECIFIED BY A SEPARATE ENGINEERING DOCUMENT, THE FOLLOWING PAINTING SCHEDULE SHALL BE FOLLOWED:
 - a. ALL INTERNAL SURFACES : 1xRZ₁ + 1xV₁
 - b. ALL EXTERNAL SURFACES : 1xRZ₂ + 1xV₁+1xV₂, AS PER HY0674162.
 - c. SHADE : RAL 7032
3. DRY FILM THICKNESS50+125+75 MICRONS PARTS IN FABRICATED CONDITION
4. SURFACE AREA FOR PAINTING 360 M2

REMARKS:

1. REFER TO TG34969 FOR INSTRUCTIONS DURING STATOR FABRICATION.
2. STATOR FRAME IS MACHINED ON BEARING SEATING AREA ONLY. HENCE UTMOST CARE IS TO BE TAKEN TO PREVENT DISTORTION.
3. DURING FIT-UP STAGE STATOR FRAME BOTTOM PART SHALL BE MATCHED WITH STATOR FRAME TOP PART TO PREVENT GAPS BETWEEN RADIAL RIBS TO MAINTAIN OVER ALL DIMENSIONS.
4. W.P.S.NO: WE006.
5. 100% D.P CHECK ON LIFTING LUG WELDS. 10% D.P AT ALL THE REMAINING WELDS AS PER AA0850131. ACCEPTANCE AS PER AA0850129.
6. BLAST CLEAN THE FRAME TO GRADE Sa 2 1/2 AS PER I.S.9954 AFTER FINAL WELDING. APPLY 1xRZ₂ IMMEDIATELY AFTER BLAST CLEANING AND CLEANING WITH THINNER.
7. ALL THE EXTERNAL WELD SEAMS SHALL BE UNIFORMLY GROUND. CASING JOINT WELD SEAM SHALL BE GROUND IN FLUSH WITH CASING SURFACE. PARTS IS 1.0mm Max.

ITEM NO.		DESCRIPTION	DRAWING NO.	W/L NO.	RAW MATERIAL SIZE OR CASTING DRG. NO. OR FORGING DRG. NO.	MATERIAL CODE	NET WT.	GROSS WT.	28450	1
						MATERIAL SPECN.	QUANTITY			
THE FOLLOWING CONDITIONS APPLY EXCEPT OTHERWISE STATED.....						TYPE OF PRODUCT: TARI 930-30P				
1. REF. TO HHG20201 FOR UNSPECIFIED TOLERANCES.						NAME OF CUSTOMER/PROJECT: BHARAT HEAVY ELECTRICALS LIMITED HYDERABAD				
2. CHAMFER W/C.D. SHARP EDGES 1:2 AT 45°.						DRN. ALP/RAJESH				
3. INTERNAL W/C.D. CORNER RADI 1 TO 0.7						CHK. BLASIM				
4. THE SURFACE ROUGHNESS WHEREVER NOT SHOWN SHALL BE TAKEN FROM THE SURFACE ROUGHNESS SHOWN OUT SIDE BACK SLASHES GIVEN AT THE TOP MOST RIGHT CORNER OF THE DRG.						APP. K.C./S.A				
DATE: 04.05.16						SCALE: NTS				
REV. DATE ALTERED						WEIGHT (KG): 28450				
1. ENCLOSURE AND MAIN BRACKET ASSEMBLIES REMOVED.						REF. TO ASSY DRG. NO. 11350131430				
2. SURFACE AREA AND MASS UPDATED.						ITEM NO. 1				
ZONE						NO. OF ITEMS NA				
TITLE: STATOR FRAME WELDMENT						DRAWING NO. 01350131212				
						REV. 02				
						SHEET NO. 01				
						NO OF SHEETS 01				

DRG.NO. 2-135-01-31327/00

THE INFORMATION ON THIS DOCUMENT IS THE PROPERTY OF BHARAT HEAVY ELECTRICALS LIMITED. IT MUST NOT BE USED DIRECTLY OR INDIRECTLY IN ANY WAY DETRIMENTAL TO THE INTEREST OF THE COMPANY.

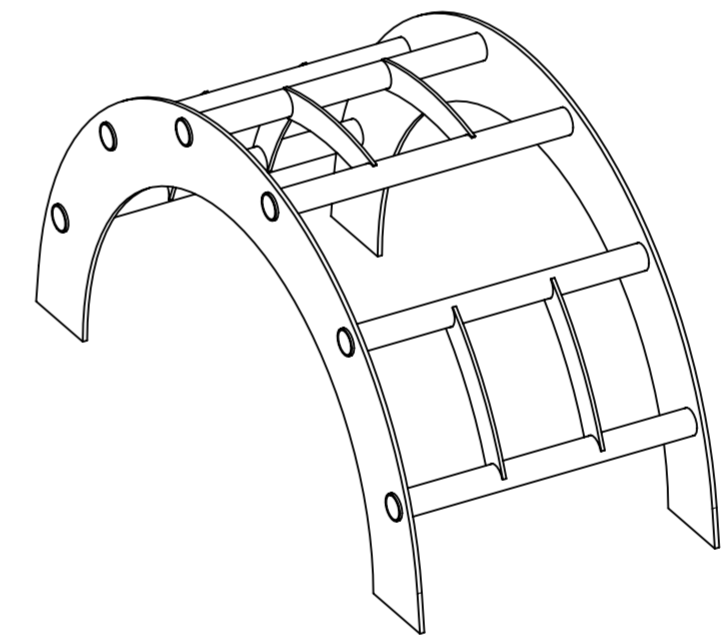
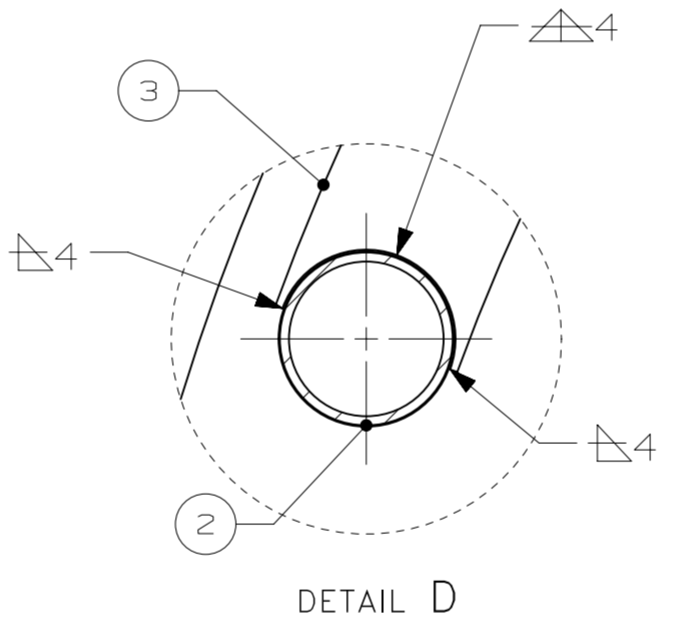
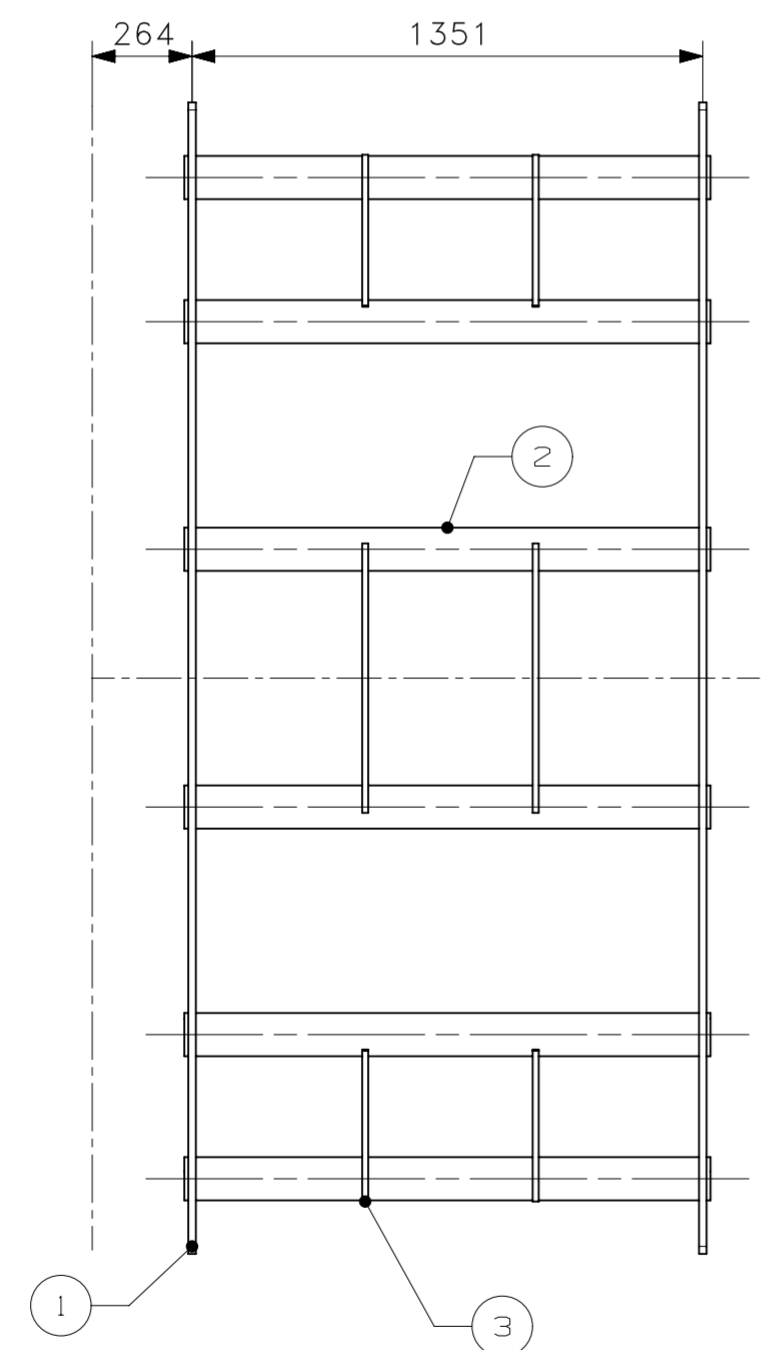
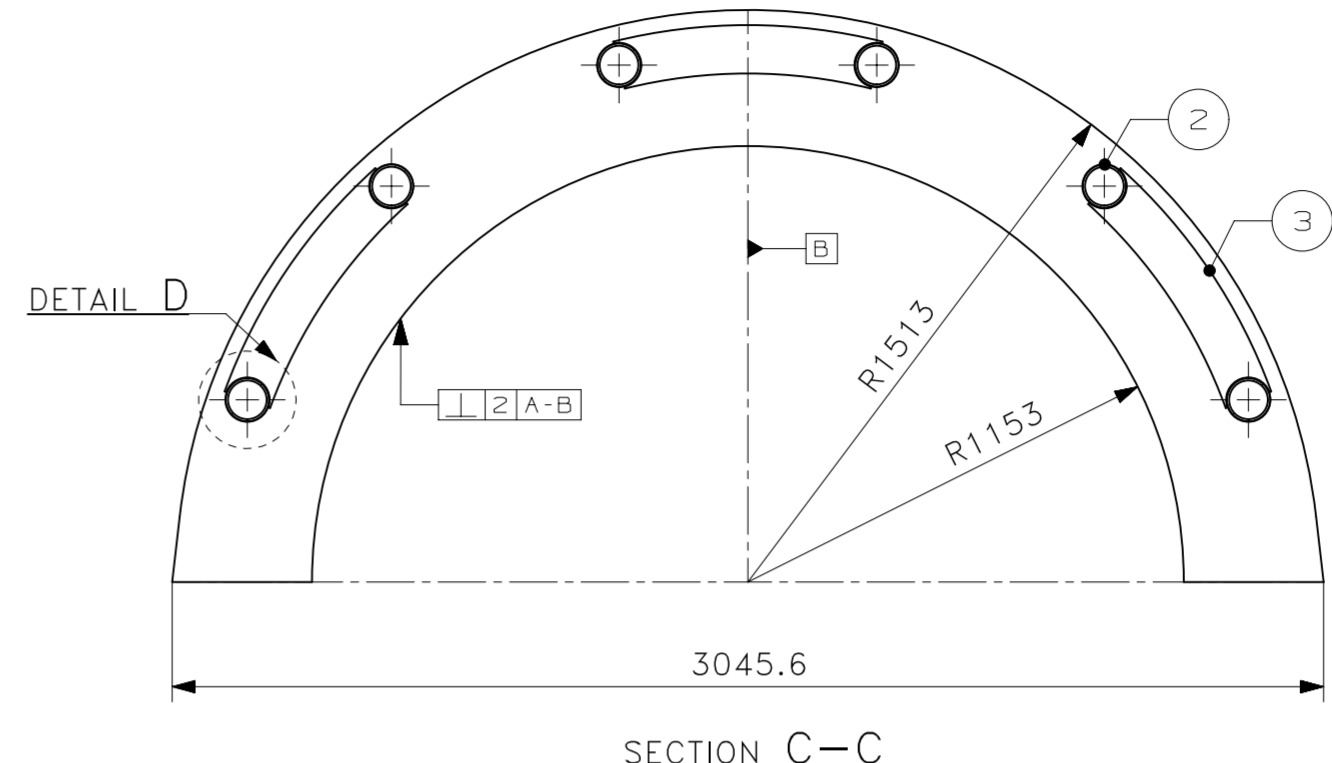
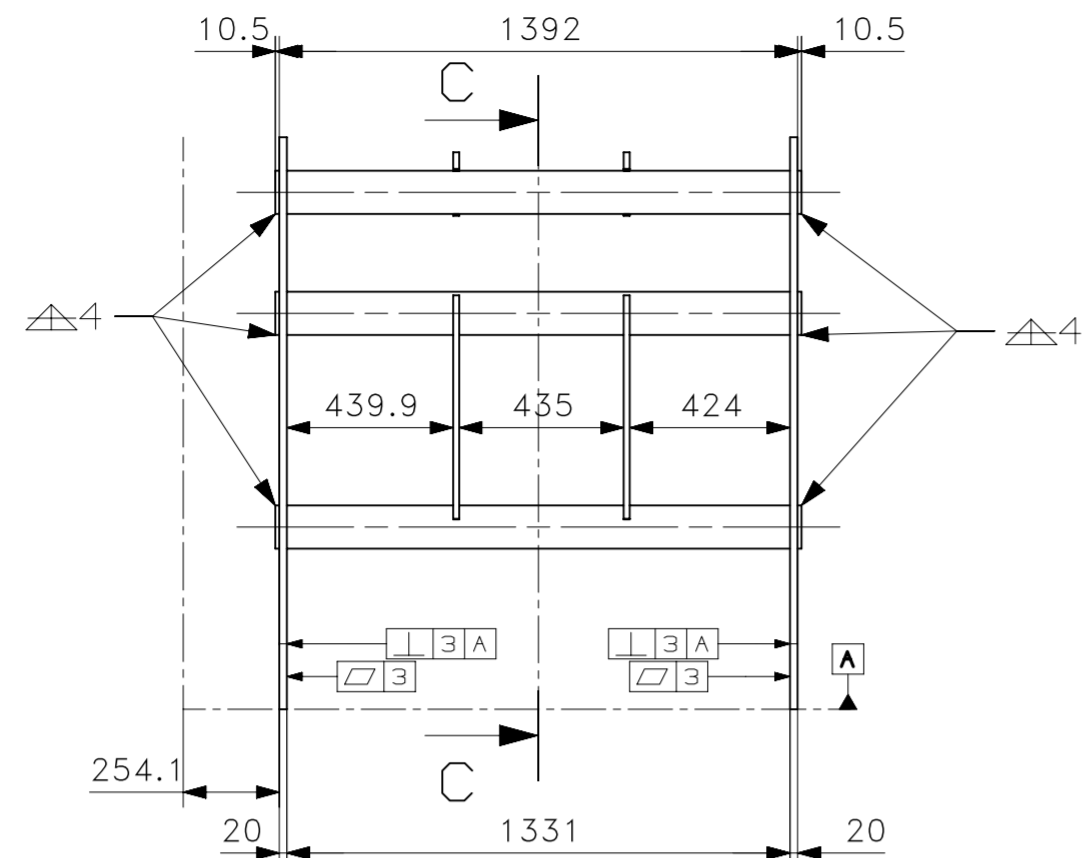

ITEM NO.	DESCRIPTION	DRAWING NO.	VAR. NO.	RAW MATERIAL SIZE OR CASTING DRG.NO. OR FORGING DRG.NO.	MATERIAL CODE	NET WT.	GROSS WT.
						859.94	
							2

THE FOLLOWING CONDITIONS APPLY EXCEPT OTHERWISE STATED...

- REF. TO HY0230261 FOR UNSPECIFIED TOLERANCES.
- CHAMFER M/CD SHARP EDGES 1.2 TO 1.0 AT 45°.
- INTERNAL M/CD CORNER RADI 1 TO 0.7.
- THE SURFACE ROUGHNESS WHEREVER NOT SHOWN SHALL BE TAKEN FROM THE SURFACE ROUGHNESS SHOWN OUT SIDE BACK SLASHES GIVEN AT THE TOP MOST RIGHT CORNER OF THE DRG.

TYPE OF PRODUCT OR NAME OF CUSTOMER/PROJECT: TARI - 930 - 30P

DRN.	A. PRAMODH	SIGN.		DATE	28.01.16	NO. OF VAR.	
CHD.	M. ASIM				28.01.16		N.A
APPD.	K. C. PANDA				28.01.16		N.A

DEPT. EME | CODE 425 | SCALE N.T.S | WEIGHT (kg) 859.94

BHARAT HEAVY ELECTRICALS LTD. HYDERABAD

TITLE: AIR BAFFLE ASSEMBLY

DRAWING NO. 2-135-01-31327 | SHEET NO. 01 | NO OF SHEETS 01

REV.	DATE	ALTERED	APPD.	REV.	DATE	ALTERED	APPD.	REV.	DATE	ALTERED	APPD.	REV.	DATE	ALTERED	APPD.
		CHECKED				CHECKED				CHECKED				CHECKED	
ZONE				ZONE				ZONE				ZONE			

THE INFORMATION ON THIS DOCUMENT IS THE PROPERTY OF BHARAT HEAVY ELECTRICALS LIMITED. IT MUST NOT BE USED DIRECTLY OR INDIRECTLY IN ANY WAY DETRIMENTAL TO THE INTEREST OF THE COMPANY

DRG. NO. 3-135-01-33821/00

25

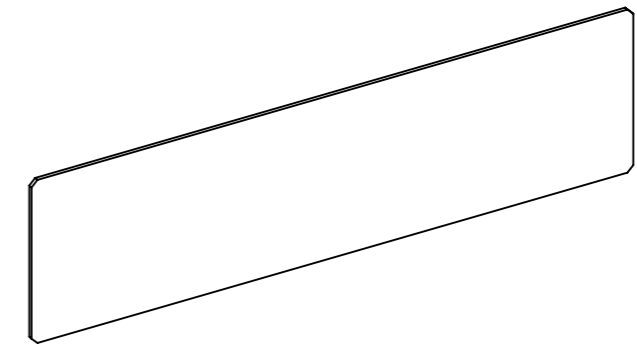
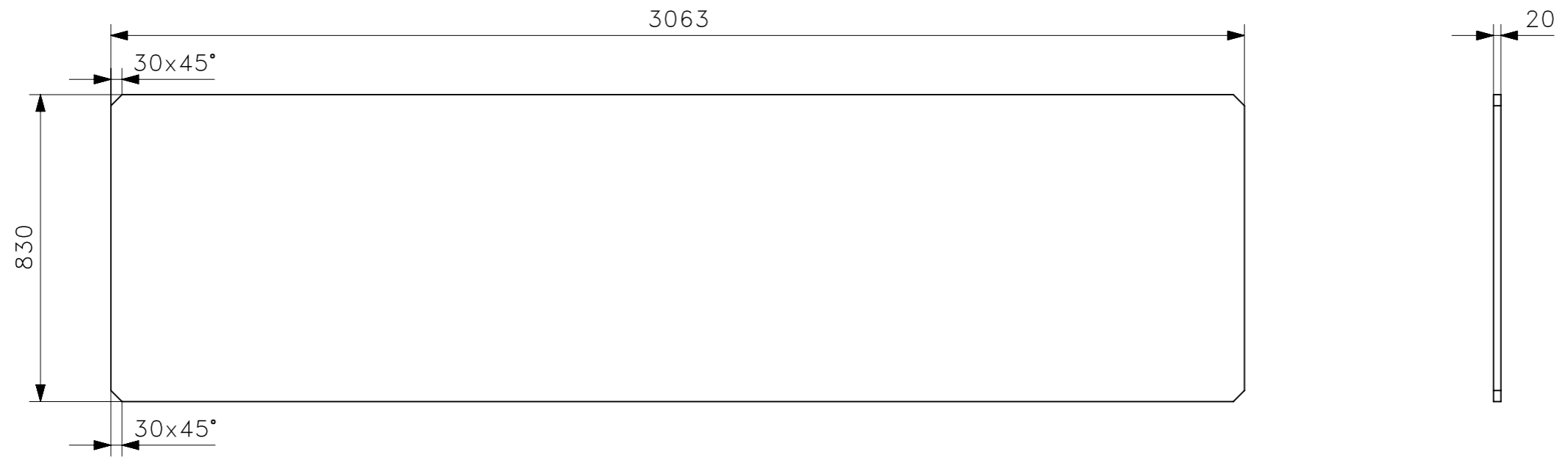

				PL: 20	AA1011819139	397.87
					AA10119	1
ITEM NO.	DESCRIPTION	DRAWING NO.	VAR. NO.	RAW MATERIAL SIZE OR CASTING DRG. NO. OR FORGING DRG. NO.	MATERIAL CODE	UNIT WT
					MATERIAL SPECN.	QUANTITY

THE FOLLOWING CONDITIONS APPLY EXCEPT OTHERWISE STATED....

- REF. TO HY0230261 FOR UNSPECIFIED TOLERANCES.
- CHAMFER M/CD. SHARP EDGES 1.2 TO 1.0 AT 45°.
- INTERNAL M/CD. CORNER RADII 1 TO 0.7
- THE SURFACE ROUGHNESS WHEREVER NOT SHOWN SHALL BE TAKEN FROM THE SURFACE ROUGHNESS SHOWN OUT SIDE BACK SLASHES GIVEN AT THE TOP MOST RIGHT CORNER OF THE DRG.

TYPE OF PRODUCT OR NAME OF CUSTOMER/PROJECT

TARI-930-30P

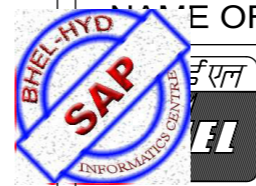

BHARAT HEAVY ELECTRICALS LTD. HYDERABAD

	NAME	SIGN.	DATE	NO.OF VAR.
DRN.	A.PRAMODH		22.01.16	NA
GHD.	M.ASIM		22.01.16	
APPD.	K.C.PANDA		22.01.16	

REV.	DATE	ALTERED	CHECKED/ APPD
ZONE			

DEPT. EME		SCALE N.T.S	WEIGHT (KG) 397.87	REF. TO ASSY DRG. 01350131206	ITEM NO. 5	NO.OF ITEMS NA
CODE 425		TITLE TS IN BOARD END PLATE	CARD CODE NA	DRAWING NO. 3-135-01-33821	REV. 00	
SHEET No. /				NO OF SHEETS /		

THE INFORMATION ON THIS DOCUMENT IS THE PROPERTY OF BHARAT HEAVY ELECTRICALS LIMITED. IT MUST NOT BE USED DIRECTLY OR INDIRECTLY IN ANY WAY DETRIMENTAL TO THE INTEREST OF THE COMPANY

DRG. NO. 3-135-01-33822/00

12.5

POS. NO.	VAR. NO.	DESCRIPTION	QTY.	LENGTH L	WIDTH W	THK. T	CHAMF. C	WEIGHT KG.	MAT. CODE
7	01	B.M.P. AT CENTER	1	2781	628	25	9	366	AA1011819155
8	02	B.M.P. AT 2nd RIB	2	2781	100	25	9	59	AA1011819155
9	03	B.M.P. AT 3RD RIB	2	2781	242	25	9	141	AA1011819155
10	04	B.M.P. AT 4th RIB	2	2781	231	25	9	135	AA1011819155
11	05	B.M.P. AT TS AIR I/L SIDE	2	98	269	25	9	5.5	AA1011819155
12	05	B.M.P. AT ES AIR I/L SIDE	2	98	269	25	9	5.5	AA1011819155
13	06	B.M.P. AT TS OH SIDE	2	814	321	25	9	55	AA1011819155
14	07	B.M.P. AT TS HZ1 SIDE	2	456	390	6	3	8.5	AA1011808030
15	07	B.M.P. AT ES HZ1 SIDE	2	456	390	6	3	8.5	AA1011808030
16	08	B.M.P. AT TS HZ2 SIDE	2	525	390	6	3	9.5	AA1011808030
17	08	B.M.P. AT ES HZ2 SIDE	2	525	390	6	3	9.5	AA1011808030
18	09	B.M.P. AT TS AIR I/L MID	1	98	130	25	9	2.6	AA1011819155
19	10	B.M.P. AT TS OH MID	1	814	130	25	9	22.5	AA1011819155
20	11	B.M.P. AT TS HZ1 MID	2	456	130	25	9	12.5	AA1011819155
21	12	B.M.P. AT TS HZ2 MID	2	525	130	25	9	14.5	AA1011819155
22	12	B.M.P. AT ES HZ2 MID	2	525	130	25	9	14.5	AA1011819155
23	11	B.M.P. AT ES HZ1 MID	2	456	130	25	9	12.5	AA1011819155
25	06	B.M.P. AT ES OH SIDE	2	814	321	25	3	55	AA1011819155
26	09	B.M.P. AT ES AIR I/L MID	1	98	130	25	9	2.6	AA1011819155

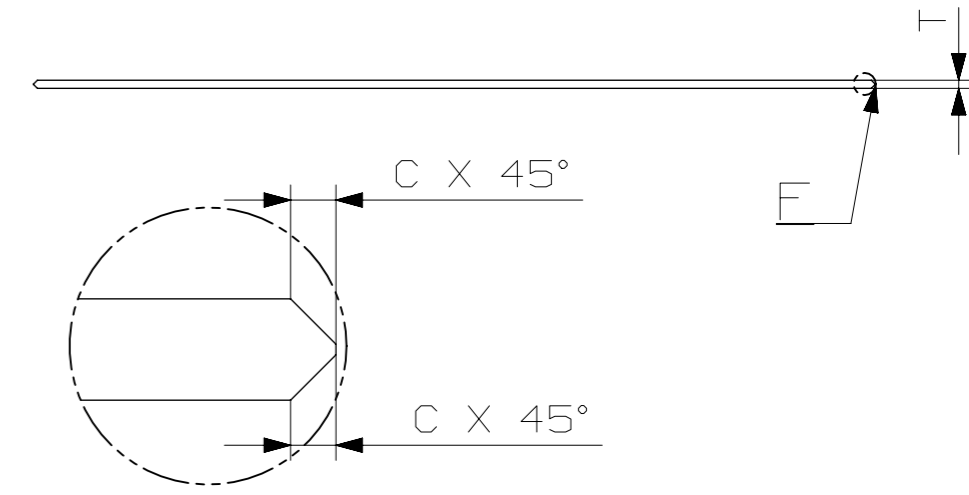
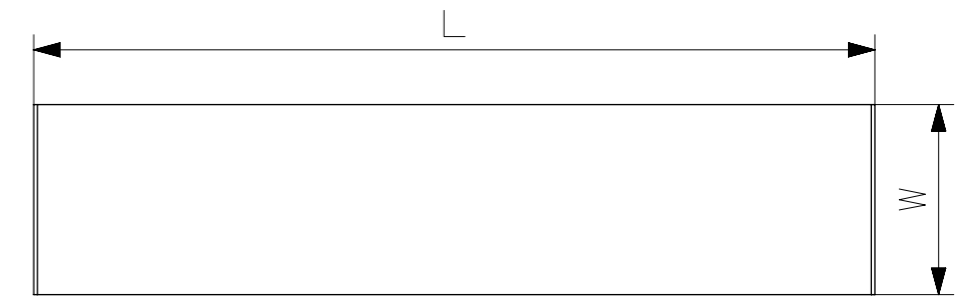

DETAIL F

* ADAPT DIMENSIONS SUITABLY TO MEET ASSEMBLY REQUIREMENTS.

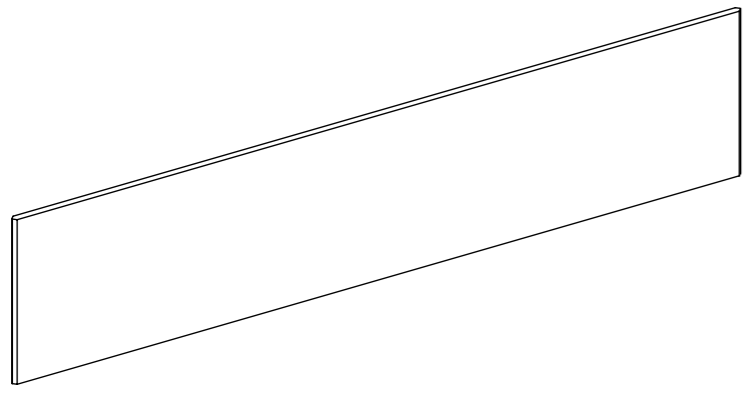

ITEM NO.	DESCRIPTION	DRAWING NO.	VAR. NO.	RAW MATERIAL SIZE OR CASTING DRG. NO. OR FORGING DRG. NO.	REFER TABLE	SEE TABLE
					AA10119	SEE TABLE
					MATERIAL CODE	UNIT WT
					MATERIAL SPECN.	QUANTITY

THE FOLLOWING CONDITIONS APPLY EXCEPT OTHERWISE STATED....

- REF. TO HY0230261 FOR UNSPECIFIED TOLERANCES.
- CHAMFER M/CD. SHARP EDGES 1.2 TO 1.0 AT 45°.
- INTERNAL M/CD. CORNER RADII 1 TO 0.7
- THE SURFACE ROUGHNESS WHEREVER NOT SHOWN SHALL BE TAKEN FROM THE SURFACE ROUGHNESS SHOWN OUT SIDE BACK SLASHES GIVEN AT THE TOP MOST RIGHT CORNER OF THE DRG.

TYPE OF PRODUCT OR NAME OF CUSTOMER/PROJECT

TARI-930-30P

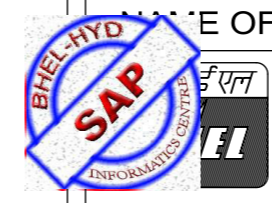

BHARAT HEAVY ELECTRICALS LTD. HYDERABAD

DRN.	NAME	SIGN.	DATE	NO. OF VAR.
A.PRAMODH			28.01.16	NA
M.ASIM			28.01.16	
K.C.PANDA			28.01.16	

REV.	DATE	ALTERED	CHECKED/ APPD

DEPT. EME	SCALE N.T.S	WEIGHT (KG) SEE TABLE	REF. TO ASSY DRG. 01350131206	ITEM NO. TABLE	NO. OF ITEMS NA
CODE 425					
TITLE BOTTOM MOUNTING PLATES			CARD CODE NA	DRAWING NO. 3-135-01-33822	
			SHEET No. /		REV. 00

DRG. NO. 3-135-01-33823/00

THE INFORMATION ON THIS DOCUMENT IS THE PROPERTY OF BHARAT HEAVY ELECTRICALS LIMITED. IT MUST NOT BE USED DIRECTLY OR INDIRECTLY IN ANY WAY DETRIMENTAL TO THE INTEREST OF THE COMPANY

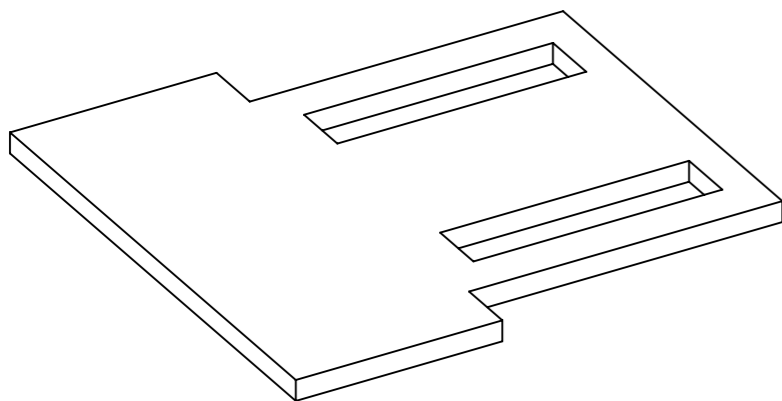
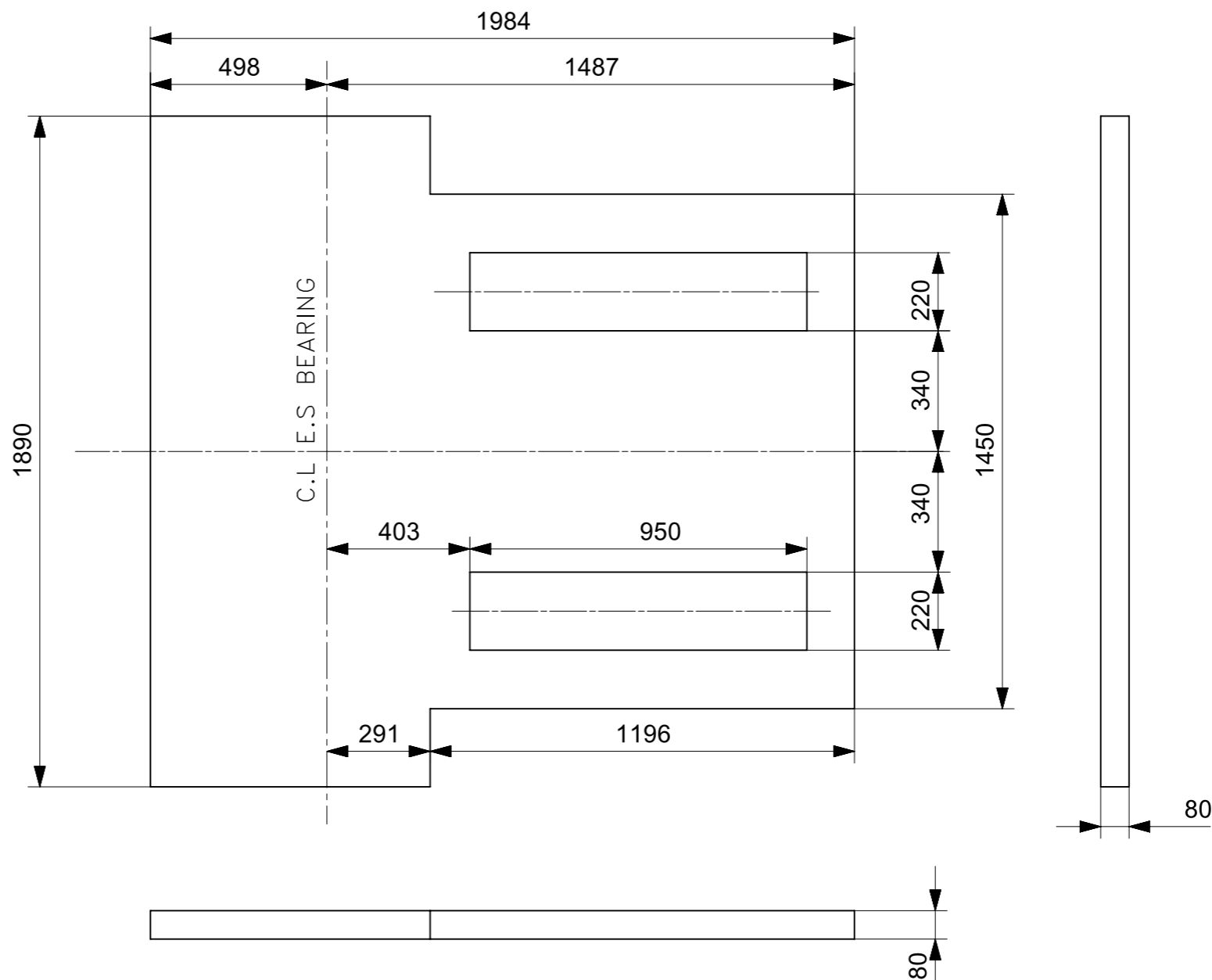

				PL: 80	AA1011819260	1760.50
					AA10119	1
ITEM NO.	DESCRIPTION	DRAWING NO.	VAR. NO.	RAW MATERIAL SIZE OR CASTING DRG. NO. OR FORGING DRG. NO.	MATERIAL CODE	UNIT WT
					MATERIAL SPECN.	QUANTITY

THE FOLLOWING CONDITIONS APPLY EXCEPT OTHERWISE STATED....

- REF. TO HY0230261 FOR UNSPECIFIED TOLERANCES.
- CHAMFER M/CD. SHARP EDGES 1.2 TO 1.0 AT 45°.
- INTERNAL M/CD. CORNER RADII 1 TO 0.7
- THE SURFACE ROUGHNESS WHEREVER NOT SHOWN SHALL BE TAKEN FROM THE SURFACE ROUGHNESS SHOWN OUT SIDE BACK SLASHES GIVEN AT THE TOP MOST RIGHT CORNER OF THE DRG.

TYPE OF PRODUCT OR NAME OF CUSTOMER/PROJECT

TARI-930-30P



BHARAT HEAVY ELECTRICALS LTD. HYDERABAD

	NAME	SIGN.	DATE	NO.OF VAR.
DRN.	A.PRAMODH		22-01-16	NA
GHD.	M.ASIM		22-01-16	
APPD.	K.C.PANDA		22-01-16	

DEPT. EME	SCALE N.T.S	WEIGHT (KG) 1760.50	REF. TO ASSY DRG. 01350131206	ITEM NO. 33	NO.OF ITEMS NA
CODE 425			DRAWING NO. 3-135-01-33823		REV. 00
TITLE E.S BEARING BED PLATE			CARD CODE NA	SHEET No. / NO OF SHEETS: /	

REV.	DATE	ALTERED	CHECKED/ APPD
ZONE			

DRG. NO. 3-135-01-33825/00

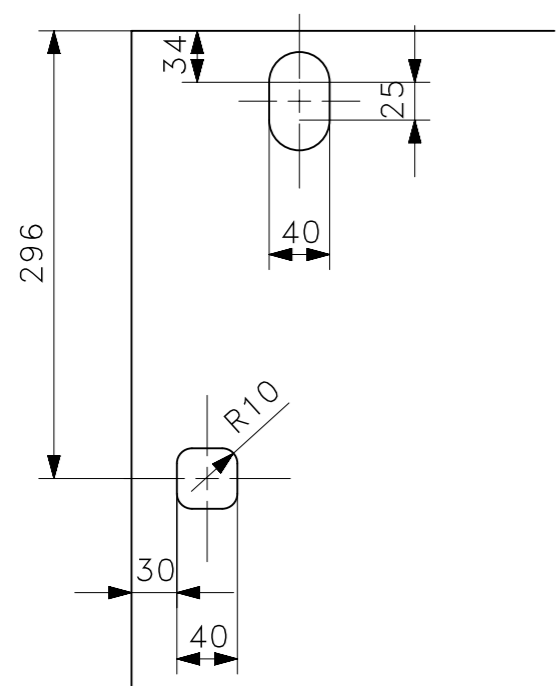
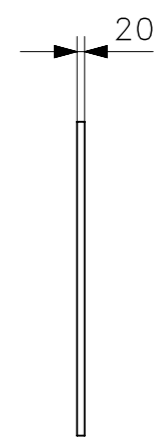
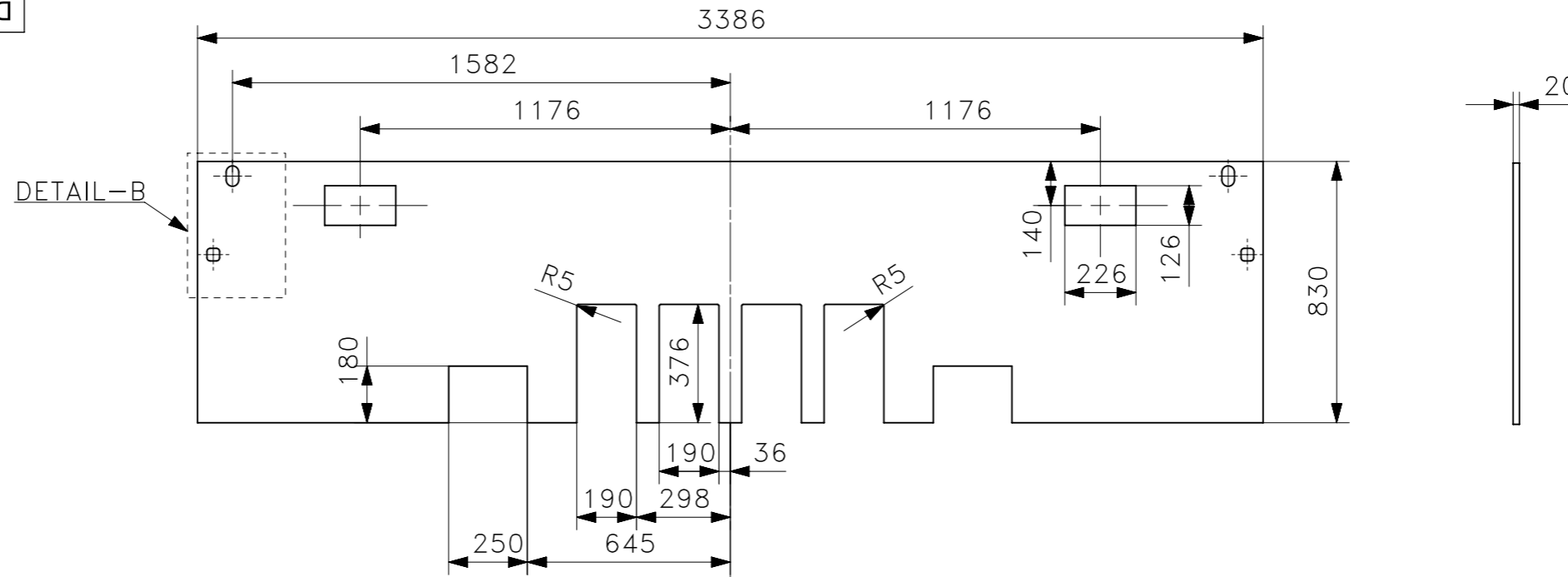

DETAIL B
SCALE 1:5

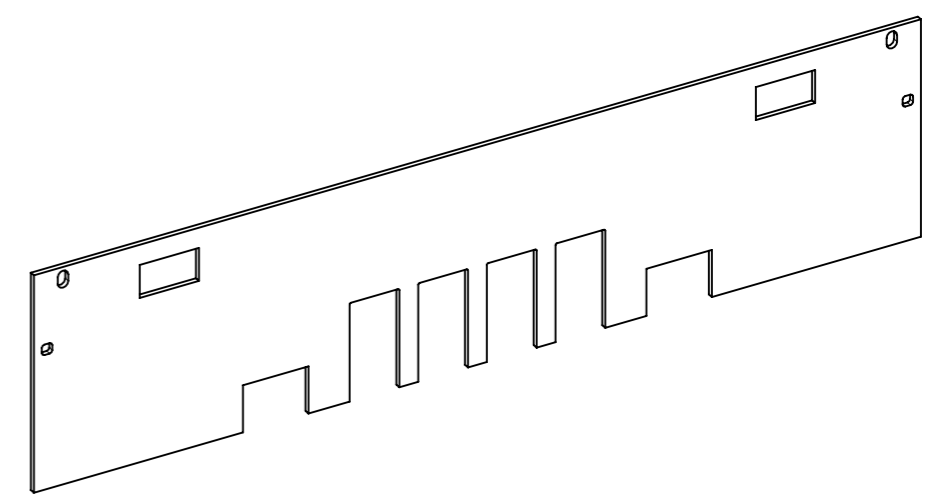

* ADAPT SUITABLY

ITEM NO.	DESCRIPTION	DRAWING NO.	VAR. NO.	RAW MATERIAL SIZE OR CASTING DRG. NO. OR FORGING DRG. NO.	PL: 20	AA1011819139	376
						AA10119	1
						MATERIAL SPECN.	QUANTITY

THE FOLLOWING CONDITIONS APPLY EXCEPT OTHERWISE STATED....

- REF. TO HY0230261 FOR UNSPECIFIED TOLERANCES.
- CHAMFER M/CD. SHARP EDGES 1.2 TO 1.0 AT 45°.
- INTERNAL M/CD. CORNER RADII 1 TO 0.7
- THE SURFACE ROUGHNESS WHEREVER NOT SHOWN SHALL BE TAKEN FROM THE SURFACE ROUGHNESS SHOWN OUT SIDE BACK SLASHES GIVEN AT THE TOP MOST RIGHT CORNER OF THE DRG.

TYPE OF PRODUCT OR NAME OF CUSTOMER/PROJECT		TARI-930-30P										
BHARAT HEAVY ELECTRICALS LTD. HYDERABAD		DRN.	A.PRAMODH	SIGN.	DATE	NO.OF VAR.						
		GHD.	M.ASIM		22-01-16	NA						
		APPD.	K.C.PANDA		22-01-16							
DEPT.	EME	SCALE	N.T.S	WEIGHT (KG)	376.10	REF. TO ASSY DRG.	01350131206	ITEM NO.	35	NO.OF ITEMS	NA	
CODE	425	TITLE		ES OUT BOARD END PLATE		CARD CODE	NA	DRAWING NO.		3-135-01-33825	REV.	00
SHEET No.:		NO OF SHEETS:										

INVENTORY NO. SIGN. AND DATE COMP. FILE NAME THE INFORMATION ON THIS DOCUMENT IS THE PROPERTY OF BHARAT HEAVY ELECTRICALS LIMITED. IT MUST NOT BE USED DIRECTLY OR INDIRECTLY IN ANY WAY DETRIMENTAL TO THE INTEREST OF THE COMPANY

DRG. NO. 3-135-01-33827/00

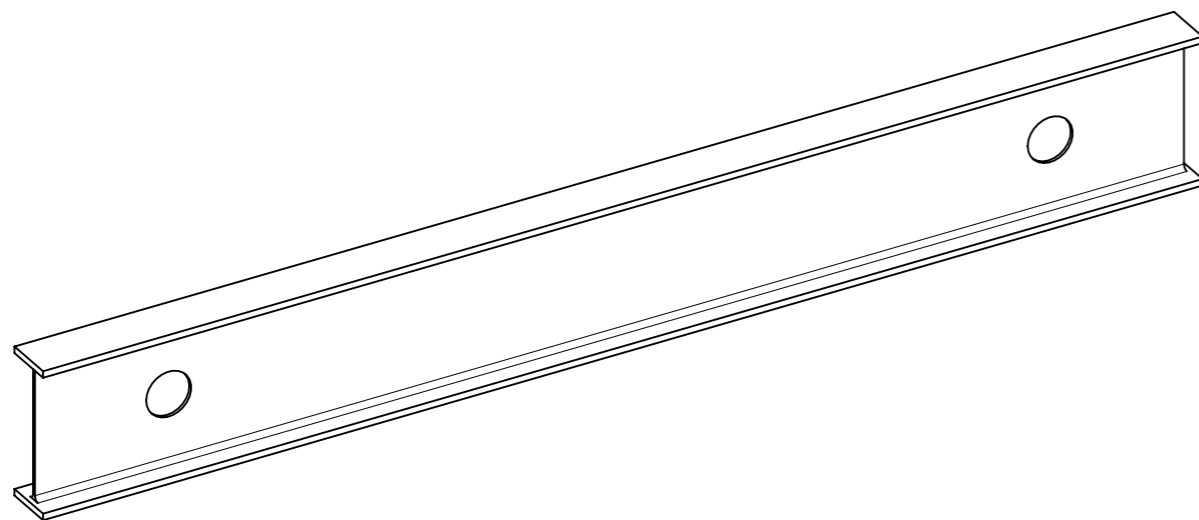
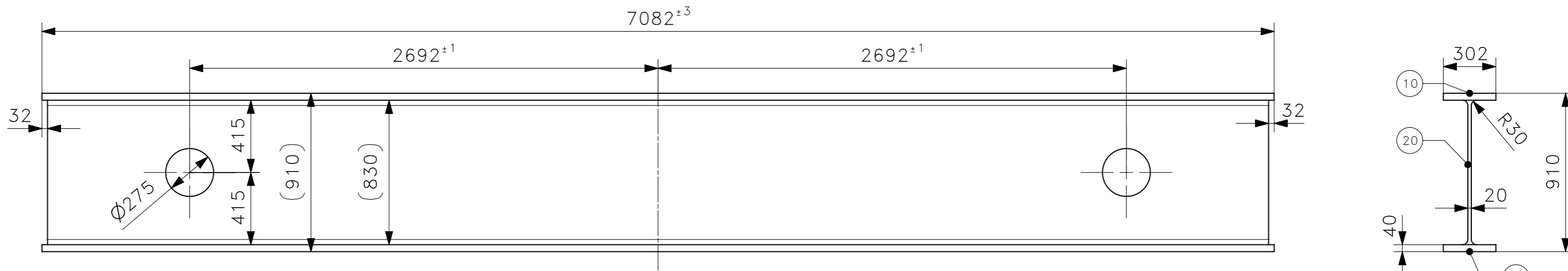

REMARKS:

1. APPLICABLE WPS NO: WE006.
2. PREHEAT THE PLATES WITH THICKNESS ABOVE 31 MM. BEFORE WELDING.
3. 100% DP CHECK THE ROOT LAYER & FINAL WELD OF BEAM FLANGES & WEB AS PER AA0850129 & AA0850131.
4. U.T TO BE DONE ON WELD JOINTS AS PER HY0850160.
5. IF THICKNESS OF PLATE IS ABOVE 38 MM. AND IT IS NOT AVAILABLE IN SINGLE LENGTH, IT CAN BE MADE BY WELDING TWO PLATES AND THEN IT SHALL BE STRESS RELIEVED.
6. ENSURE STRAIGHTNESS OF THE BEAM AFTER WELDING.
7. WELD, GRIND FLUSH AND D.P FILLET WELDS BETWEEN BEAM WEB AND TIE PLATES: 100% D.P. CRACKS ARE NOT PERMITTED.
8. GRIND THE WELD SEAM IN FLUSH WITH THE PLATE SURFACE.
9. DEBURR ALL THE SHARP EDGES.
10. ADAPT DURING ASSEMBLY.
11. STRESS RELIEVE THE JOINTS SUITABLY.

THE INFORMATION ON THIS DOCUMENT IS THE PROPERTY OF BHARAT HEAVY ELECTRICALS LIMITED. IT MUST NOT BE USED DIRECTLY OR INDIRECTLY IN ANY WAY DETRIMENTAL TO THE INTEREST OF THE COMPANY

INVENTORY NO. SIGN. AND DATE COMP. FILE NAME

						2316.91
						2
ITEM NO.	DESCRIPTION	DRAWING NO.	VAR. NO.	RAW MATERIAL SIZE OR CASTING DRG. NO. OR FORGING DRG. NO.	MATERIAL CODE	UNIT WT
					MATERIAL SPECN.	QUANTITY

THE FOLLOWING CONDITIONS APPLY EXCEPT OTHERWISE STATED....

1. REF. TO HY0230261 FOR UNSPECIFIED TOLERANCES.
2. CHAMFER M/CD. SHARP EDGES 1.2 TO 1.0 AT 45°.
3. INTERNAL M/CD. CORNER RADII 1 TO 0.7
4. THE SURFACE ROUGHNESS WHEREVER NOT SHOWN SHALL BE TAKEN FROM THE SURFACE ROUGHNESS SHSOWN OUT SIDE BACK SLASHS GIVEN AT THE TOP MOST RIGHT CORNER OF THE DRG.

TYPE OF PRODUCT OR NAME OF CUSTOMER/PROJECT

TARI 930-30P

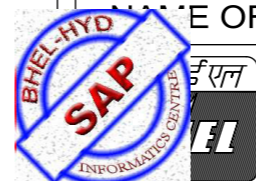

BHARAT HEAVY ELECTRICALS LTD. HYDERABAD

	NAME	SIGN.	DATE	NO.OF VAR.
DRN.	A.PRAMODH		14.01.16	NA
GHD.	M.ASIM		14.01.16	
APPD.	K.C.PANDA		14.01.16	

DEPT. EME	SCALE N.T.S	WEIGHT (KG) 2316.91	REF. TO ASSY DRG. 01350131207	ITEM NO. 1	NO.OF ITEMS NA
CODE 425			DRAWING NO. 3-135-01-33827		REV. 00
TITLE LONGITUDINAL I-BEAM ROLLED			CARD CODE NA	SHEET No. / NO OF SHEETS: /	

THE INFORMATION ON THIS DOCUMENT IS THE PROPERTY OF BHARAT HEAVY ELECTRICALS LIMITED. IT MUST NOT BE USED DIRECTLY OR INDIRECTLY IN ANY WAY DETRIMENTAL TO THE INTEREST OF THE COMPANY

DRG. NO. 31350133828/00

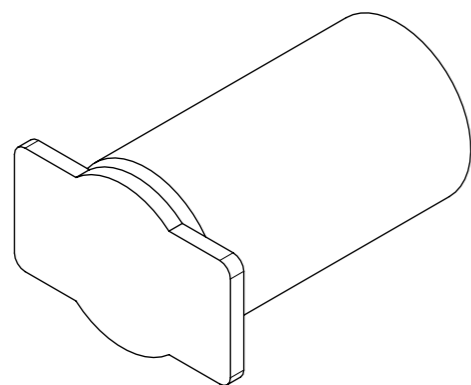
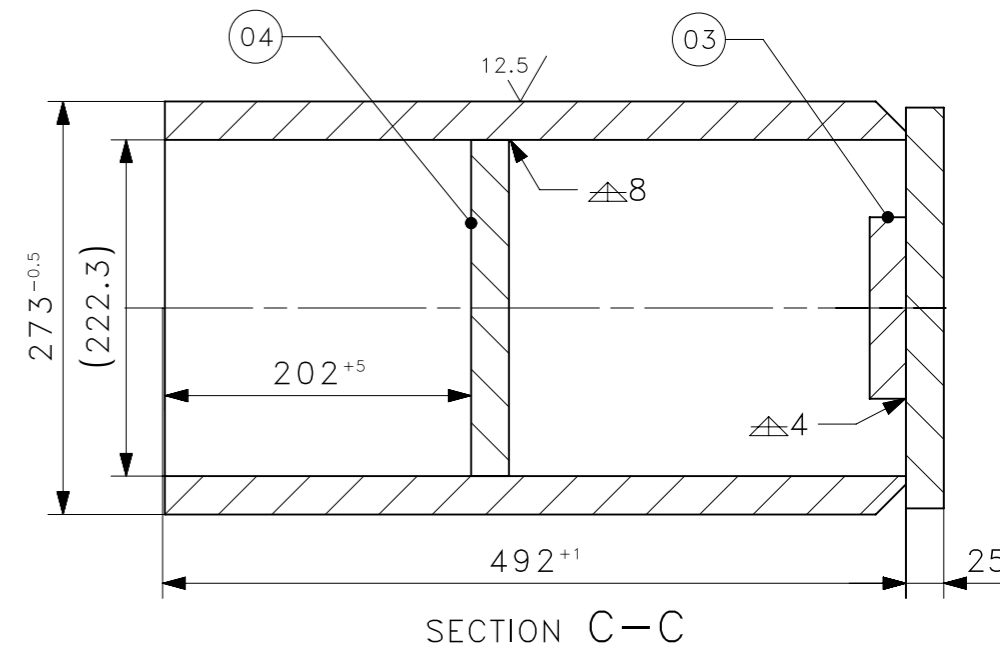
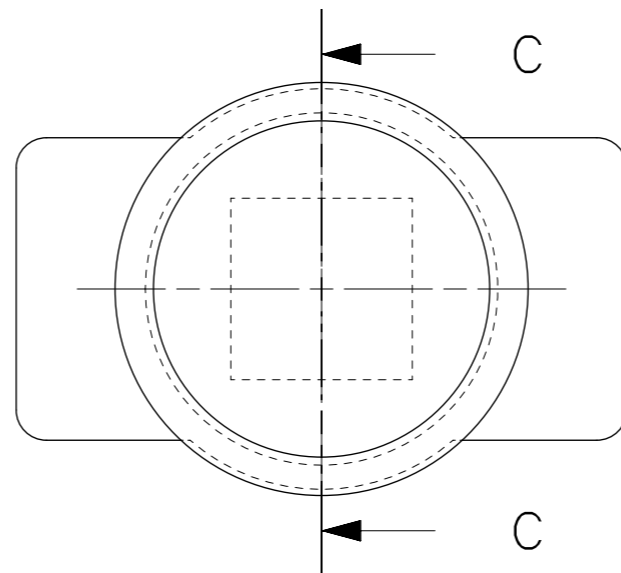
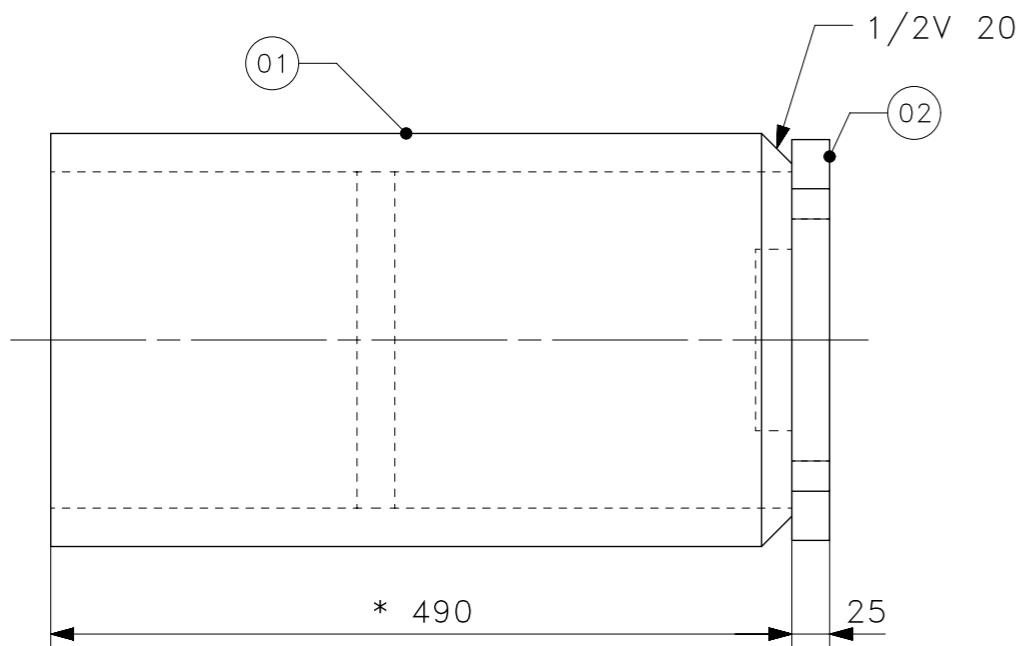

*ADAPT DURING ASSY

ITEM NO.	DESCRIPTION	DRAWING NO.	VAR. NO.	RAW MATERIAL SIZE OR CASTING DRG. NO. OR FORGING DRG. NO.	MATERIAL CODE	UNIT WT
						103.5
						4
					MATERIAL SPECN.	QUANTITY

THE FOLLOWING CONDITIONS APPLY EXCEPT OTHERWISE STATED....

- REF. TO HY0230261 FOR UNSPECIFIED TOLERANCES.
- CHAMFER M/CD. SHARP EDGES 1.2 TO 1.0 AT 45°.
- INTERNAL M/CD. CORNER RADII 1 TO 0.7
- THE SURFACE ROUGHNESS WHEREVER NOT SHOWN SHALL BE TAKEN FROM THE SURFACE ROUGHNESS SHOWN OUT SIDE BACK SLASHES GIVEN AT THE TOP MOST RIGHT CORNER OF THE DRG.

TYPE OF PRODUCT OR NAME OF CUSTOMER/PROJECT

TARI 930-30P

BHARAT HEAVY ELECTRICALS LTD. HYDERABAD

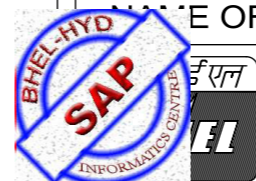

REV.	DATE	ALTERED	CHECKED/ APPD
ZONE			

DEPT. EME	SCALE NTS	WEIGHT (KG) 103.5	REF. TO ASSY DRG. 01350131207	ITEM NO. 3	NO.OF ITEMS NA
CODE 425			DRAWING NO. 31350133828		REV. 00
TITLE TRUNION ASSY WELDING			CARD CODE NA	SHEET No. / NO OF SHEETS: /	

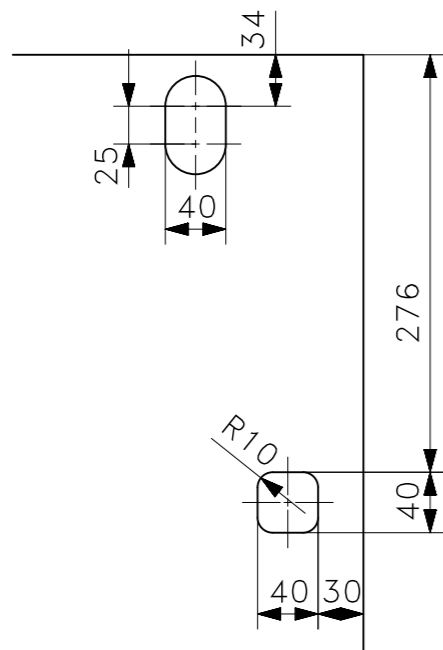

DETAIL B

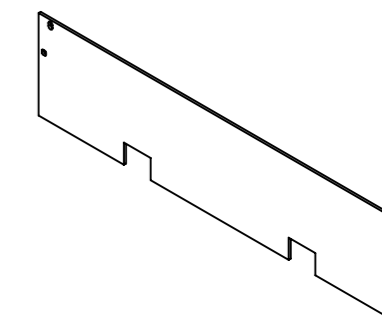
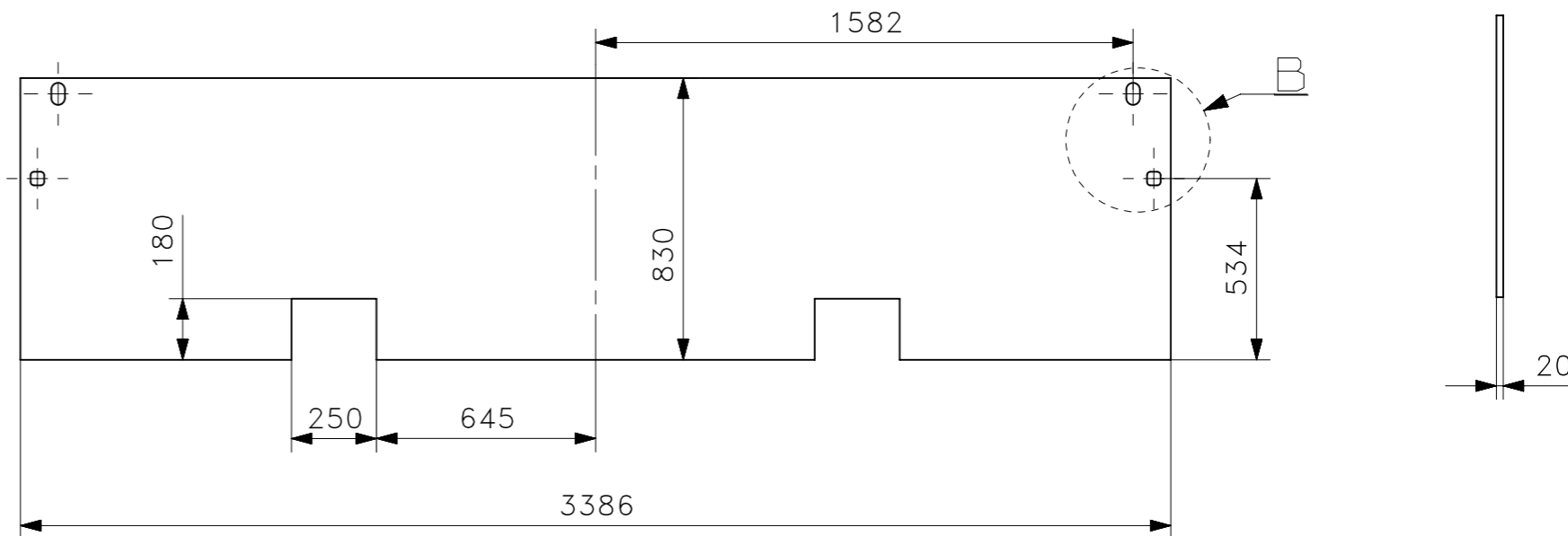

ADAPT DURING ASSY

THE INFORMATION ON THIS DOCUMENT IS THE PROPERTY OF BHARAT HEAVY ELECTRICALS LIMITED. IT MUST NOT BE USED DIRECTLY OR INDIRECTLY IN ANY WAY DETRIMENTAL TO THE INTEREST OF THE COMPANY

INVENTORY NO. SIGN. AND DATE COMP. FILE NAME

				PL:20	AA1011819139	424.90
					AA10119	1
ITEM NO.	DESCRIPTION	DRAWING NO.	VAR. NO.	RAW MATERIAL SIZE OR CASTING DRG. NO. OR FORGING DRG. NO.	MATERIAL CODE	UNIT WT
					MATERIAL SPECN.	QUANTITY

THE FOLLOWING CONDITIONS APPLY EXCEPT OTHERWISE STATED....

- REF. TO HY0230261 FOR UNSPECIFIED TOLERANCES.
- CHAMFER M/CD. SHARP EDGES 1.2 TO 1.0 AT 45°.
- INTERNAL M/CD. CORNER RADII 1 TO 0.7
- THE SURFACE ROUGHNESS WHEREVER NOT SHOWN SHALL BE TAKEN FROM THE SURFACE ROUGHNESS SHOWN OUT SIDE BACK SLASHS GIVEN AT THE TOP MOST RIGHT CORNER OF THE DRG.

TYPE OF PRODUCT OR NAME OF CUSTOMER/PROJECT

TARI-930-30P



BHARAT HEAVY ELECTRICALS LTD. HYDERABAD

	NAME	SIGN.	DATE	NO.OF VAR.
DRN.	A.PRAMODH		22-01-16	NA
GHD.	M.ASIM		22-01-16	
APPD.	K.C.PANDA		22-01-16	

DEPT. EME	SCALE NA	WEIGHT (KG) 424.9	REF. TO ASSY DRG. 01350131206	ITEM NO. 34	NO.OF ITEMS NA
CODE 425			DRAWING NO. 31350133829		REV. 00
TITLE T.S OUT BOARD END PLATE			CARD CODE NA	SHEET No.: / NO OF SHEETS: /	

THE INFORMATION ON THIS DOCUMENT IS THE PROPERTY OF BHARAT HEAVY ELECTRICALS LIMITED. IT MUST NOT BE USED DIRECTLY OR INDIRECTLY IN ANY WAY DETRIMENTAL TO THE INTEREST OF THE COMPANY

DRG. NO. 3-135-01-33830/00

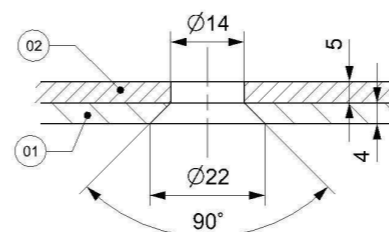
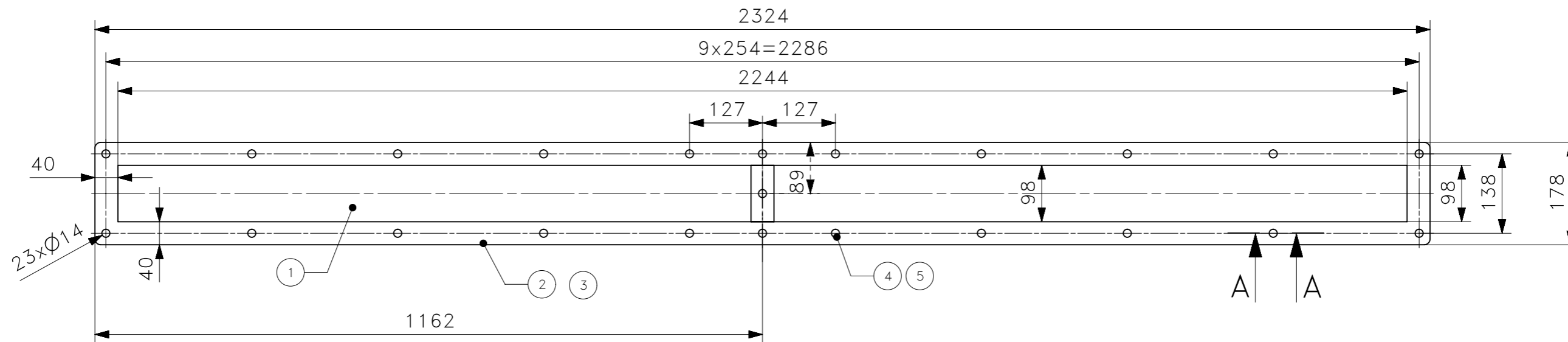

SECTION A-A

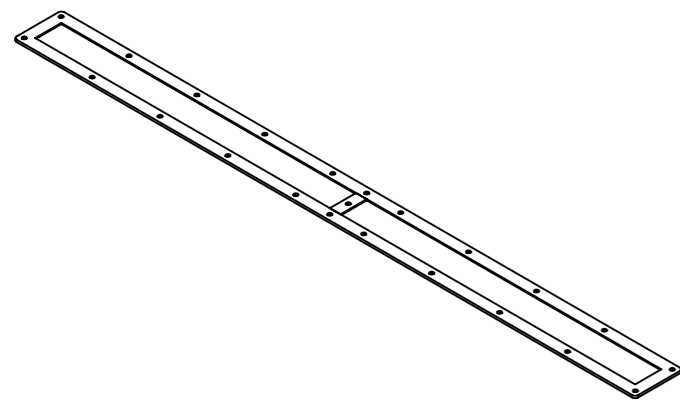

ITEM NO.	DESCRIPTION	DRAWING NO.	VAR. NO.	RAW MATERIAL SIZE OR CASTING DRG. NO. OR FORGING DRG. NO.	MATERIAL CODE	UNIT WT
						17.5
						2
					MATERIAL SPECN.	QUANTITY

THE FOLLOWING CONDITIONS APPLY EXCEPT OTHERWISE STATED....

- REF. TO HY0230261 FOR UNSPECIFIED TOLERANCES.
- CHAMFER M/CD. SHARP EDGES 1.2 TO 1.0 AT 45°.
- INTERNAL M/CD. CORNER RADII 1 TO 0.7
- THE SURFACE ROUGHNESS WHEREVER NOT SHOWN SHALL BE TAKEN FROM THE SURFACE ROUGHNESS SHOWN OUT SIDE BACK SLASHES GIVEN AT THE TOP MOST RIGHT CORNER OF THE DRG.

TYPE OF PRODUCT OR NAME OF CUSTOMER/PROJECT

TARI 930-30P

BHARAT HEAVY ELECTRICALS LTD. HYDERABAD



DEPT. EME
CODE 425

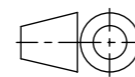

SCALE N.T.S

WEIGHT (KG) 17.50

REF. TO ASSY DRG. 01350131206

ITEM NO. 41
NO.OF ITEMS NA

TITLE
COLD ZONE COVER ASSY

CARD CODE NA

DRAWING NO. 3-135-01-33830

REV. 00

REV.	DATE	ALTERED	CHECKED/ APPD
ZONE			

THE INFORMATION ON THIS DOCUMENT IS THE PROPERTY OF BHARAT HEAVY ELECTRICALS LIMITED. IT MUST NOT BE USED DIRECTLY OR INDIRECTLY IN ANY WAY DETRIMENTAL TO THE INTEREST OF THE COMPANY

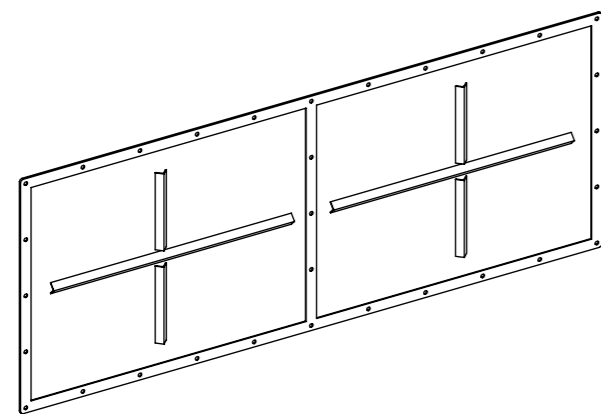
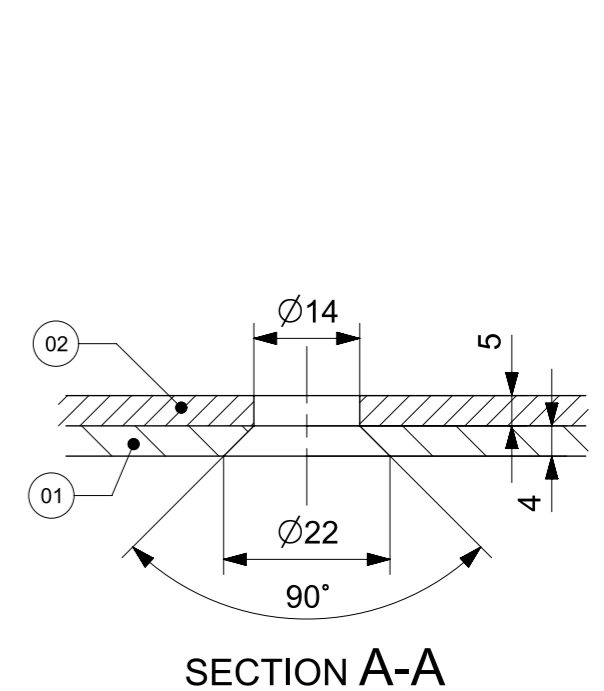
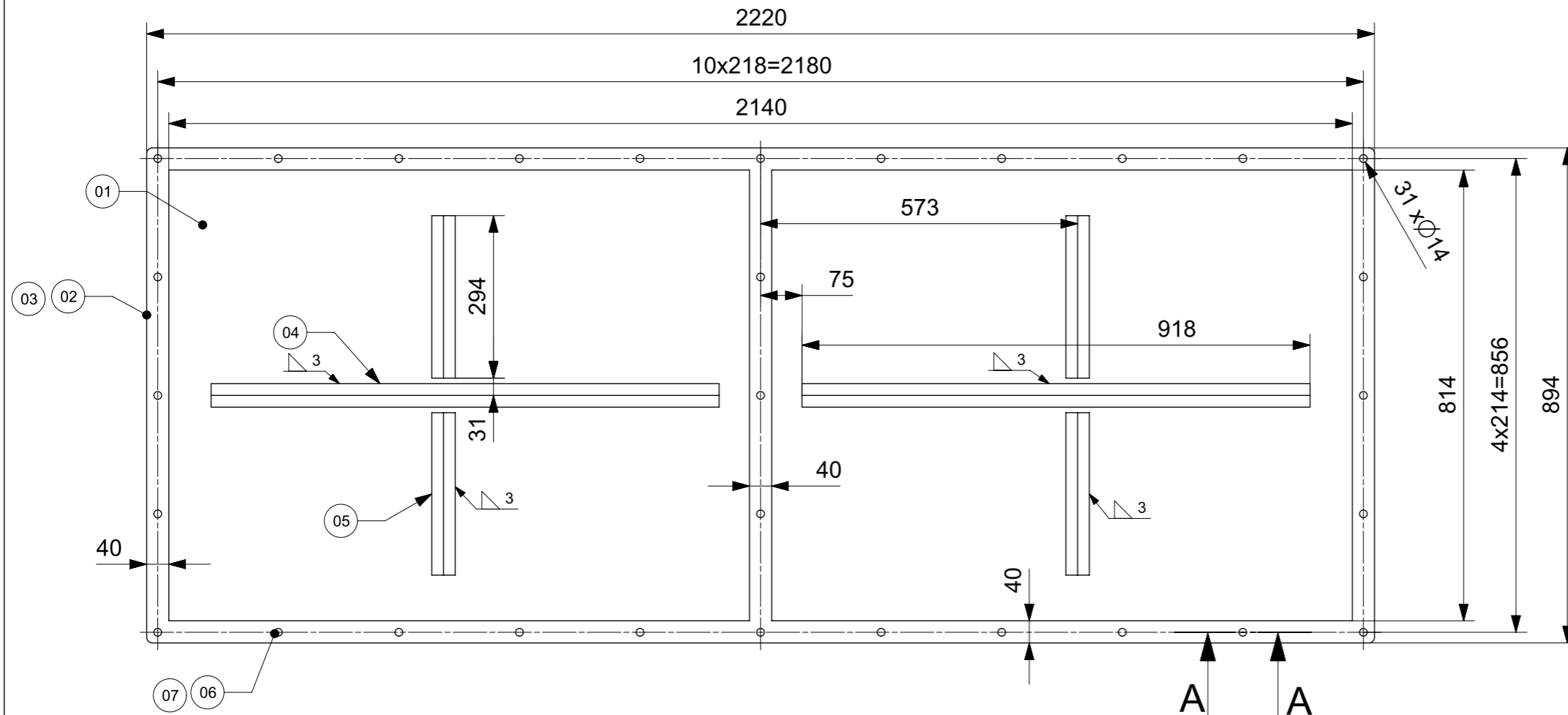

ITEM NO.	DESCRIPTION	DRAWING NO.	VAR. NO.	RAW MATERIAL SIZE OR CASTING DRG. NO. OR FORGING DRG. NO.	MATERIAL CODE	UNIT WT
						71.5
						2
					MATERIAL SPECN.	QUANTITY

THE FOLLOWING CONDITIONS APPLY EXCEPT OTHERWISE STATED....

- REF. TO HY0230261 FOR UNSPECIFIED TOLERANCES.
- CHAMFER M/CD. SHARP EDGES 1.2 TO 1.0 AT 45°.
- INTERNAL M/CD. CORNER RADII 1 TO 0.7
- THE SURFACE ROUGHNESS WHEREVER NOT SHOWN SHALL BE TAKEN FROM THE SURFACE ROUGHNESS SHOWN OUT SIDE BACK SLASHES GIVEN AT THE TOP MOST RIGHT CORNER OF THE DRG.

TYPE OF PRODUCT OR NAME OF CUSTOMER/PROJECT

TARI-930-30P

BHARAT HEAVY ELECTRICALS LTD. HYDERABAD



DEPT. EME	SCALE N.T.S	WEIGHT (KG) 71.5	REF. TO ASSY DRG. 01350131206	ITEM NO. 42	NO.OF ITEMS NA
CODE 425			DRAWING NO. 31350133831	REV. 00	
TITLE OVERHANG BOTTOM COVER ASSY			CARD CODE NA	SHEET No. / NO OF SHEETS /	

REV.	DATE	ALTERED	CHECKED/ APPD
ZONE			

DRG. NO. 3-135-01-33832/00

THE INFORMATION ON THIS DOCUMENT IS THE PROPERTY OF BHARAT HEAVY ELECTRICALS LIMITED. IT MUST NOT BE USED DIRECTLY OR INDIRECTLY IN ANY WAY DETRIMENTAL TO THE INTEREST OF THE COMPANY

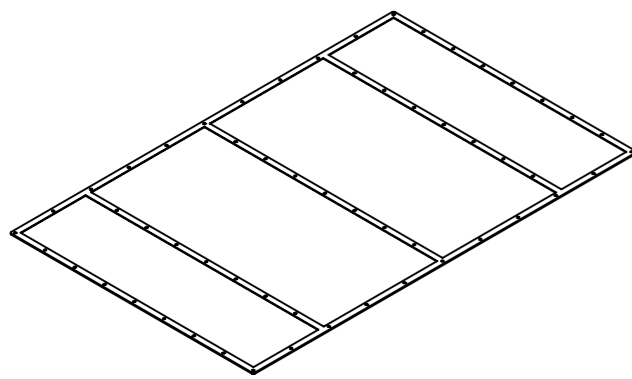
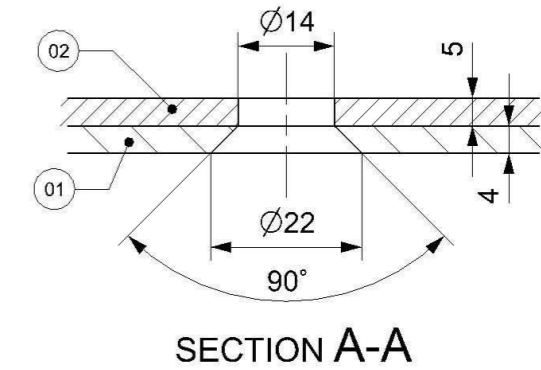
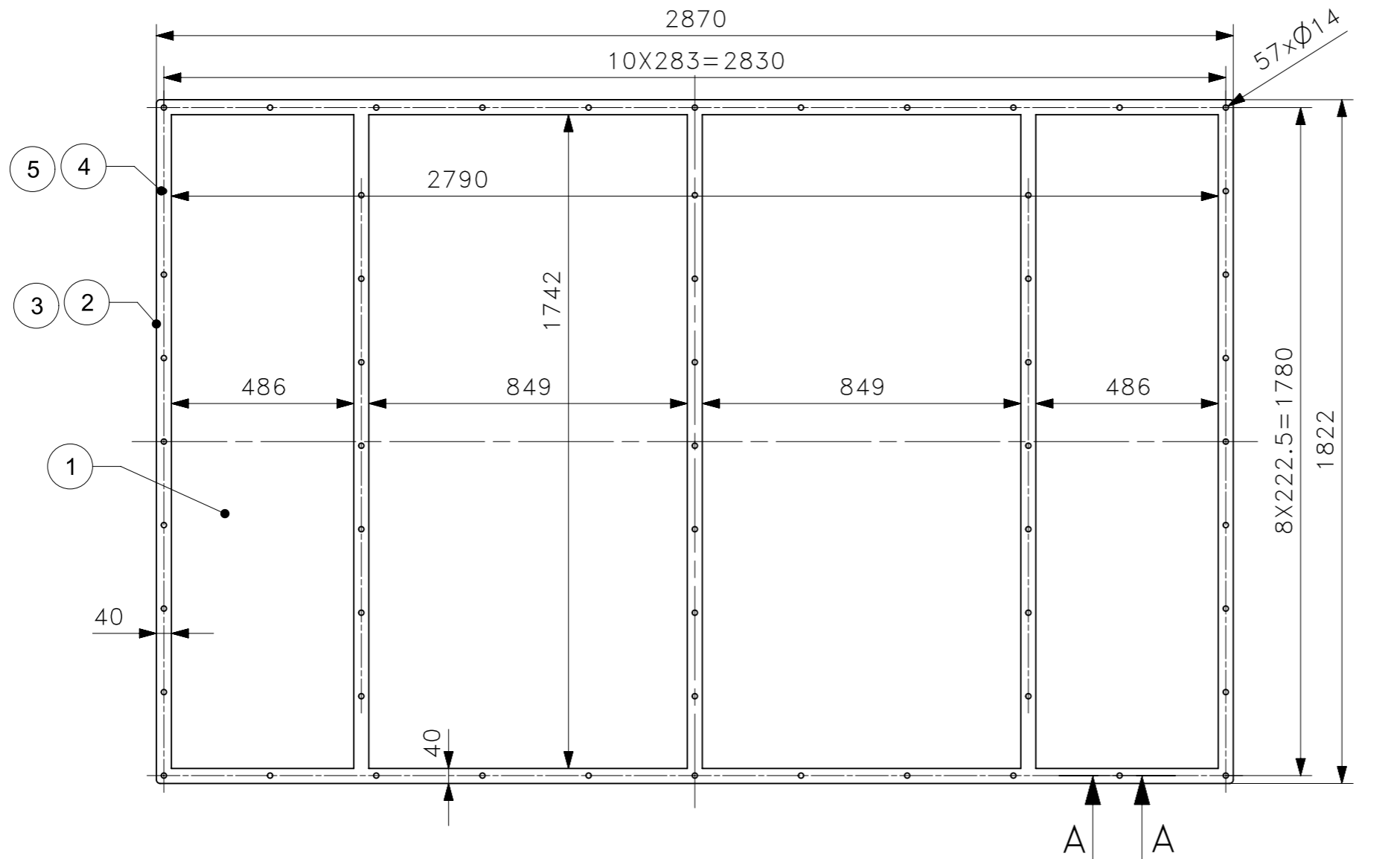

ITEM NO.	DESCRIPTION	DRAWING NO.	VAR. NO.	RAW MATERIAL SIZE OR CASTING DRG. NO. OR FORGING DRG. NO.	MATERIAL CODE	UNIT WT
						175.5
						1
					MATERIAL SPECN.	QUANTITY

THE FOLLOWING CONDITIONS APPLY EXCEPT OTHERWISE STATED....

- REF. TO HY0230261 FOR UNSPECIFIED TOLERANCES.
- CHAMFER M/CD. SHARP EDGES 1.2 TO 1.0 AT 45°.
- INTERNAL M/CD. CORNER RADII 1 TO 0.7
- THE SURFACE ROUGHNESS WHEREVER NOT SHOWN SHALL BE TAKEN FROM THE SURFACE ROUGHNESS SHOWN OUT SIDE BACK SLASHES GIVEN AT THE TOP MOST RIGHT CORNER OF THE DRG.

TYPE OF PRODUCT OR NAME OF CUSTOMER/PROJECT

TARI-930-30P



BHARAT HEAVY ELECTRICALS LTD. HYDERABAD

DRN.	A.PRAMODH	SIGN.	DATE	NO.OF VAR.
GHD.	M.ASIM		22-01-16	NA
APPD.	K.C.PANDA		22-01-16	

DEPT. EME	SCALE N.T.S	WEIGHT (KG) 175.5	REF. TO ASSY DRG. 01350131206	ITEM NO. 43	NO.OF ITEMS NA
CODE 425			DRAWING NO. 3-135-01-33832		REV. 00
TITLE HOT ZONE BOTTOM COVER ASSY			CARD CODE NA	SHEET No. / NO OF SHEETS: /	

REV.	DATE	ALTERED	CHECKED/ APPD
ZONE			

DRG. NO. 3-135-01-33834/00

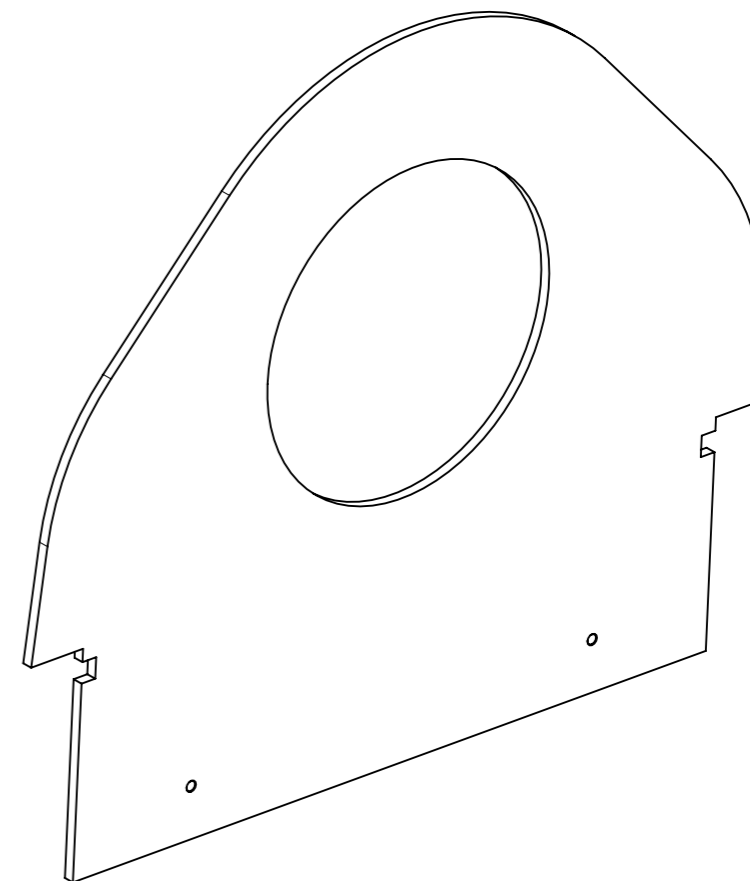
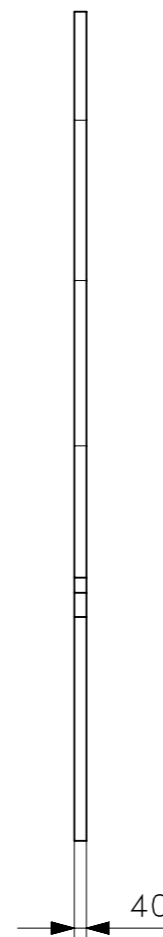
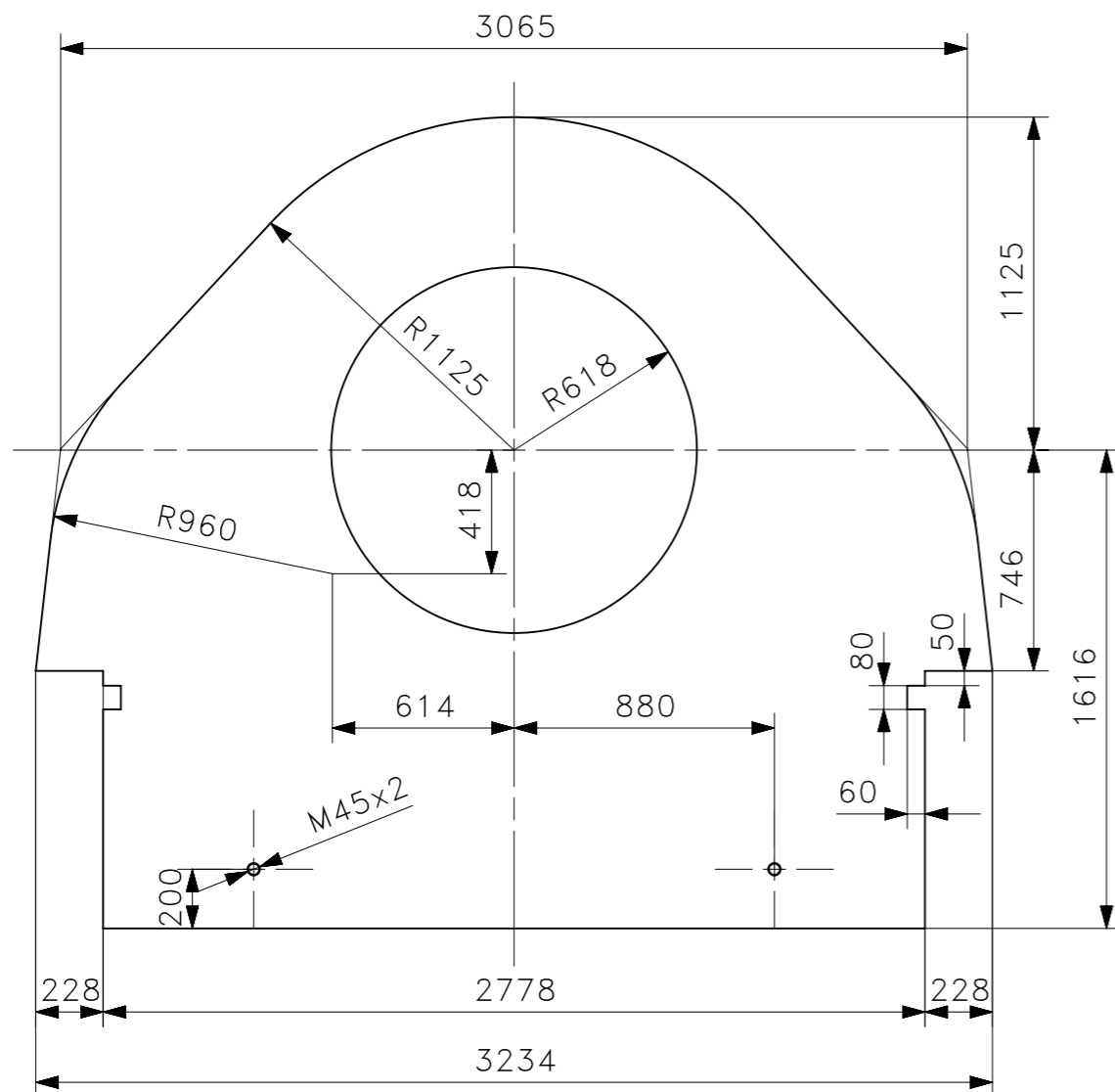

ADAPT DURING ASSY.

THE INFORMATION ON THIS DOCUMENT IS THE PROPERTY OF BHARAT HEAVY ELECTRICALS LIMITED. IT MUST NOT BE USED DIRECTLY OR INDIRECTLY IN ANY WAY DETRIMENTAL TO THE INTEREST OF THE COMPANY

INVENTORY NO. SIGN. AND DATE COMP. FILE NAME

				PL: 40	AA1011819198	1789.56
					AA10119	1
ITEM NO.	DESCRIPTION	DRAWING NO.	VAR. NO.	RAW MATERIAL SIZE OR CASTING DRG. NO. OR FORGING DRG. NO.	MATERIAL CODE	UNIT WT
					MATERIAL SPECN.	QUANTITY

THE FOLLOWING CONDITIONS APPLY EXCEPT OTHERWISE STATED....

- REF. TO HY0230261 FOR UNSPECIFIED TOLERANCES.
- CHAMFER M/CD. SHARP EDGES 1.2 TO 1.0 AT 45°.
- INTERNAL M/CD. CORNER RADII 1 TO 0.7
- THE SURFACE ROUGHNESS WHEREVER NOT SHOWN SHALL BE TAKEN FROM THE SURFACE ROUGHNESS SHOWN OUT SIDE BACK SLASHS GIVEN AT THE TOP MOST RIGHT CORNER OF THE DRG.

TYPE OF PRODUCT OR NAME OF CUSTOMER/PROJECT

TARI-930-30P



BHARAT HEAVY ELECTRICALS LTD. HYDERABAD

	NAME	SIGN.	DATE	NO.OF VAR.
DRN.	A.PRAMODH		22-01-16	NA
CHD.	M.ASIM		22-01-16	
APPD.	K.C.PANDA		22-01-16	

DEPT. EME	SCALE N.T.S	WEIGHT (KG) 1789.56	REF. TO ASSY DRG. 01350131205	ITEM NO. 10	NO.OF ITEMS NA
CODE 425	TITLE FRONT WALL TS		CARD CODE NA	DRAWING NO. 3-135-01-33834	
SHEET No. /			NO OF SHEETS /		

THE INFORMATION ON THIS DOCUMENT IS THE PROPERTY OF BHARAT HEAVY ELECTRICALS LIMITED. IT MUST NOT BE USED DIRECTLY OR INDIRECTLY IN ANY WAY DETRIMENTAL TO THE INTEREST OF THE COMPANY

DRG. NO. 3-135-01-33835/00

12.5

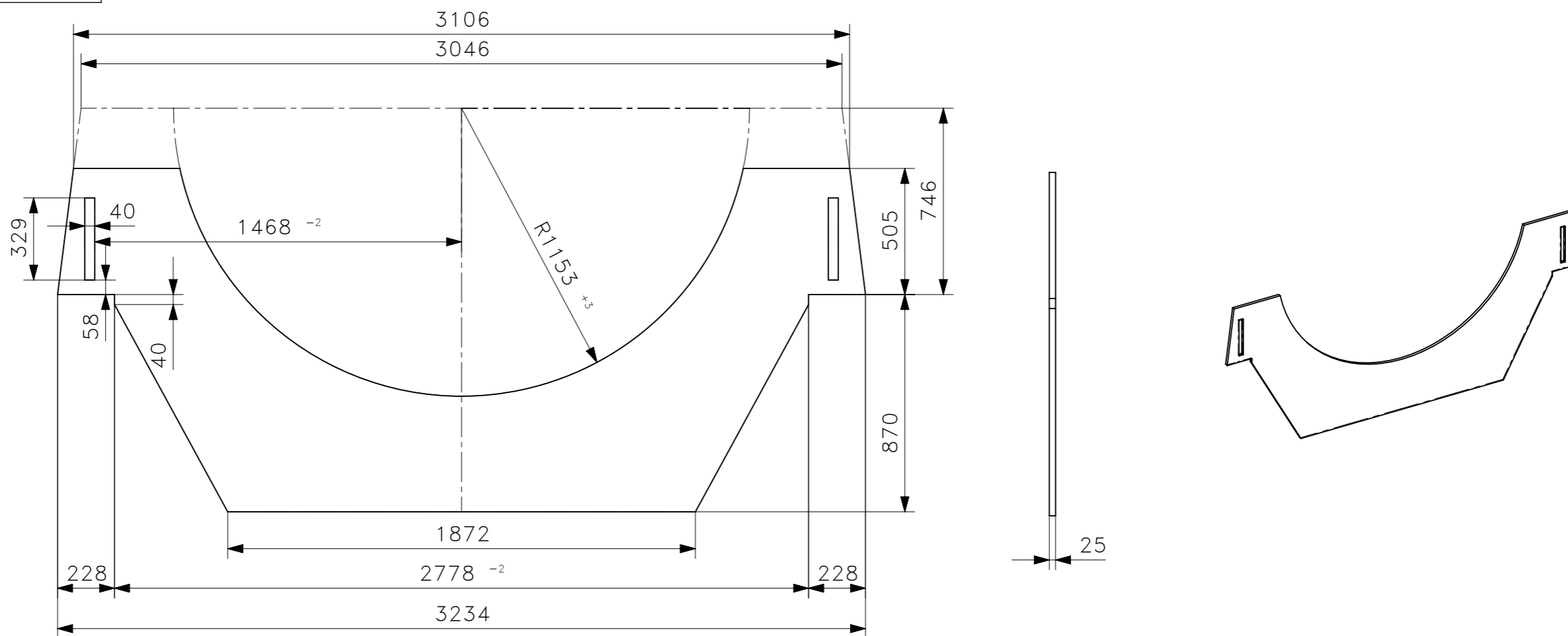

				PL: 25	AA1011819155	419.90	
					AA10119	2	
ITEM NO.	DESCRIPTION	DRAWING NO.	VAR. NO.	RAW MATERIAL SIZE OR CASTING DRG. NO. OR FORGING DRG. NO.	MATERIAL CODE	UNIT WT	
					MATERIAL SPECN.	QUANTITY	
<p>THE FOLLOWING CONDITIONS APPLY EXCEPT OTHERWISE STATED....</p> <ol style="list-style-type: none"> REF. TO HY0230261 FOR UNSPECIFIED TOLERANCES. CHAMFER M/CD. SHARP EDGES 1.2 TO 1.0 AT 45°. INTERNAL M/CD. CORNER RADII 1 TO 0.7 THE SURFACE ROUGHNESS WHEREVER NOT SHOWN SHALL BE TAKEN FROM THE SURFACE ROUGHNESS SHOWN OUT SIDE BACK SLASHS GIVEN AT THE TOP MOST RIGHT CORNER OF THE DRG. 				<p>TYPE OF PRODUCT OR NAME OF CUSTOMER/PROJECT</p> <p>TARI 930-30P</p>			
<p>BHARAT HEAVY ELECTRICALS LTD. HYDERABAD</p>				DRN.	A.PRAMODH	14.01.16	
				CHD.	M.ASIM	14.01.16	
<p>DEPT. EME</p> <p>CODE 425</p>				APPD.	K.C.PANDA	14.01.16	
				SCALE	NA	WEIGHT (KG)	419.9
<p>TITLE</p> <p>RADIAL RIB SECOND</p>				CARD CODE	NA	NO. OF SHEETS	1
				ITEM NO.	6	NO. OF ITEMS	NA
<p>REV. DATE ALTERED CHECKED/ APPD</p>				<p>NO. OF SHEETS</p>			

INVENTORY NO. SIGN. AND DATE COMP. FILE NAME

Apr Fri 15 08:06 2016

Printed by : MOHAMMAD ASIM-FME3003 / 6006175 on 04-08-16 09:54:17

This Drawing is printed from Engineering Digital Archive System (EDAS). Therefore signatures are not essentially required.

THE INFORMATION ON THIS DOCUMENT IS THE PROPERTY OF BHARAT HEAVY ELECTRICALS LIMITED. IT MUST NOT BE USED DIRECTLY OR INDIRECTLY IN ANY WAY DETRIMENTAL TO THE INTEREST OF THE COMPANY

DRG. NO. 3-135-01-33836/00

12.5 ✓

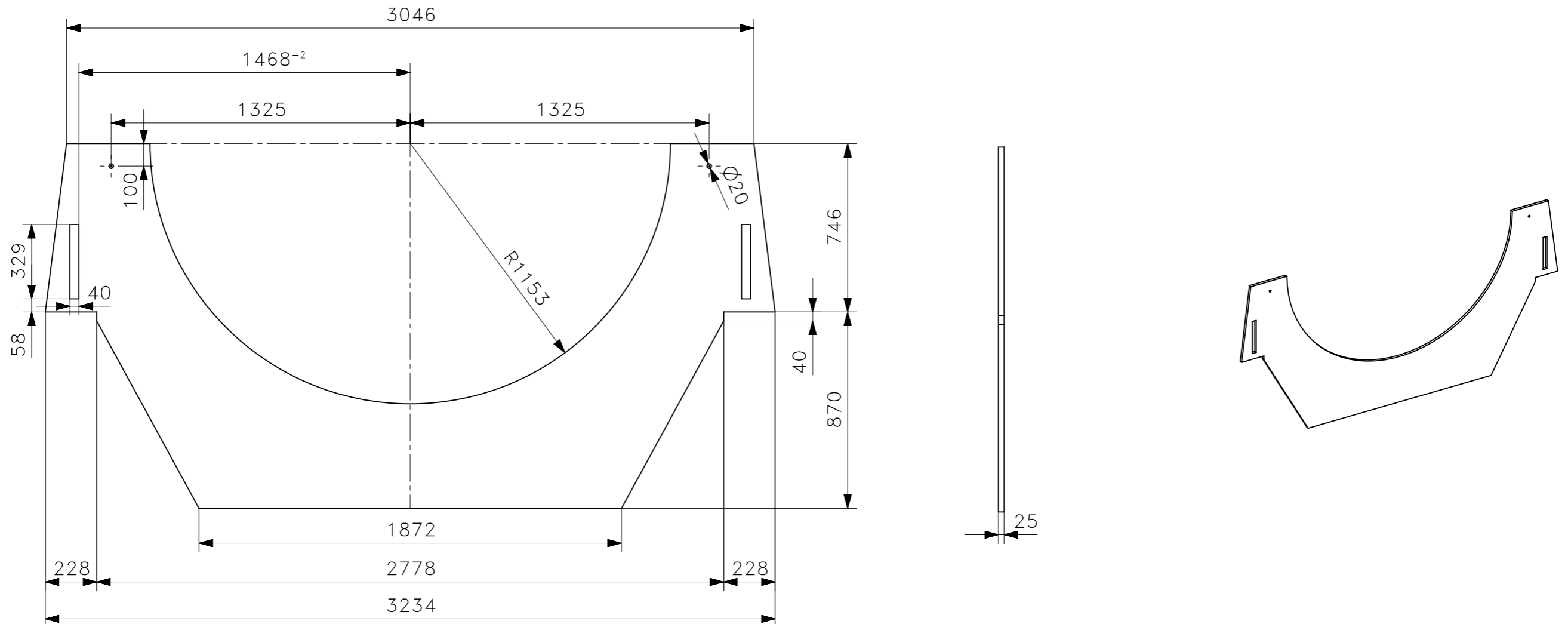

				PL:25	AA1011819155	453.90
					AA10119	2
ITEM NO.	DESCRIPTION	DRAWING NO.	VAR. NO.	RAW MATERIAL SIZE OR CASTING DRG. NO. OR FORGING DRG. NO.	MATERIAL CODE	UNIT WT
					MATERIAL SPECN.	QUANTITY

THE FOLLOWING CONDITIONS APPLY EXCEPT OTHERWISE STATED....

- REF. TO HY0230261 FOR UNSPECIFIED TOLERANCES.
- CHAMFER M/CD. SHARP EDGES 1.2 TO 1.0 AT 45°.
- INTERNAL M/CD. CORNER RADII 1 TO 0.7
- THE SURFACE ROUGHNESS WHEREVER NOT SHOWN SHALL BE TAKEN FROM THE SURFACE ROUGHNESS SHOWN OUT SIDE BACK SLASHES GIVEN AT THE TOP MOST RIGHT CORNER OF THE DRG.

TYPE OF PRODUCT OR NAME OF CUSTOMER/PROJECT
TARI 930-30P

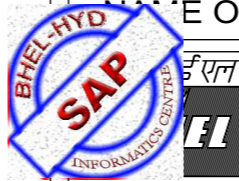

BHARAT HEAVY ELECTRICALS LTD.
HYDERABAD

	NAME	SIGN.	DATE	NO.OF VAR.
DRN.	A.PRAMODH		14.01.16	
GHD.	M.ASIM		14.01.16	NA
APPD.	K.C.PANDA		14.01.16	

REV.	DATE	ALTERED	CHECKED/ APPD
ZONE			

DEPT. EME	SCALE NA	WEIGHT (KG) 453.9	REF. TO ASSY DRG. 01350131205	ITEM NO. 5	NO.OF ITEMS NA
CODE 425	TITLE RADIAL RIB FIRST		CARD CODE NA	DRAWING NO. 3-135-01-33836	
SHEET No. 1			NO OF SHEETS 1		

DRG. NO. 3-135-01-33838/00

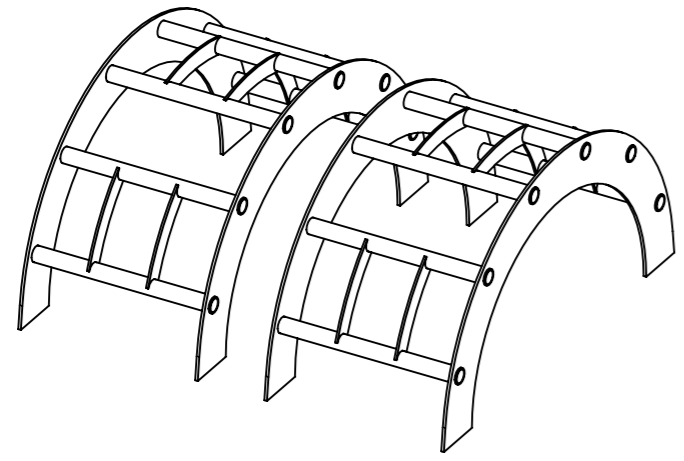
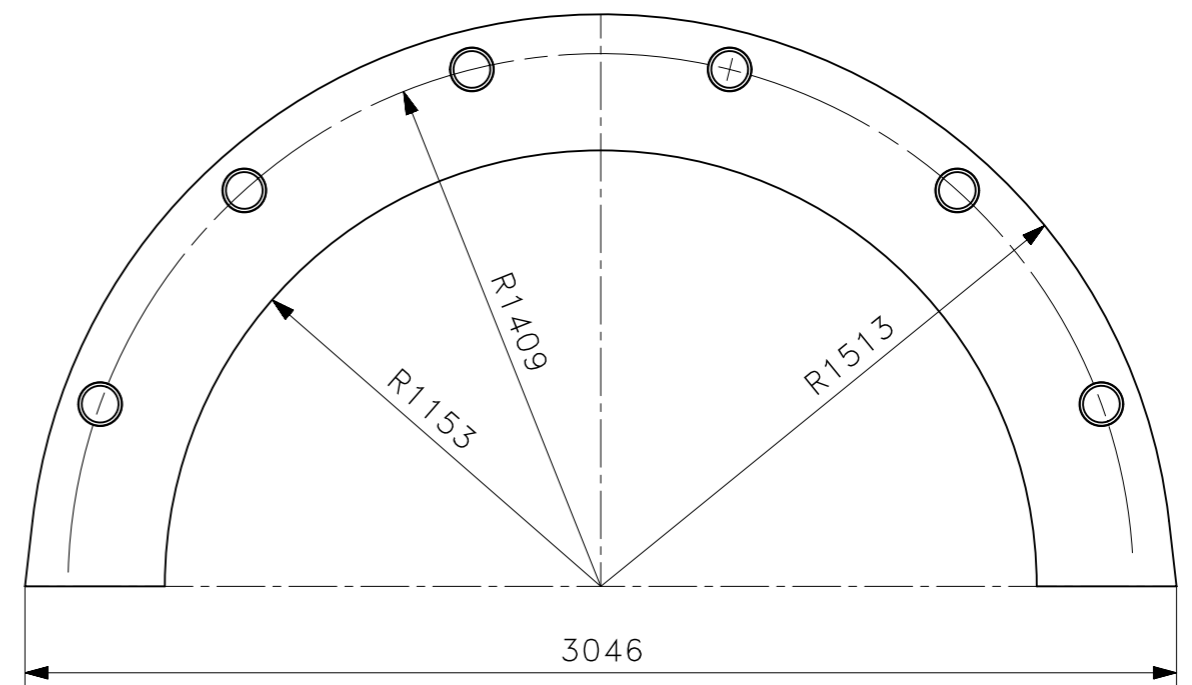
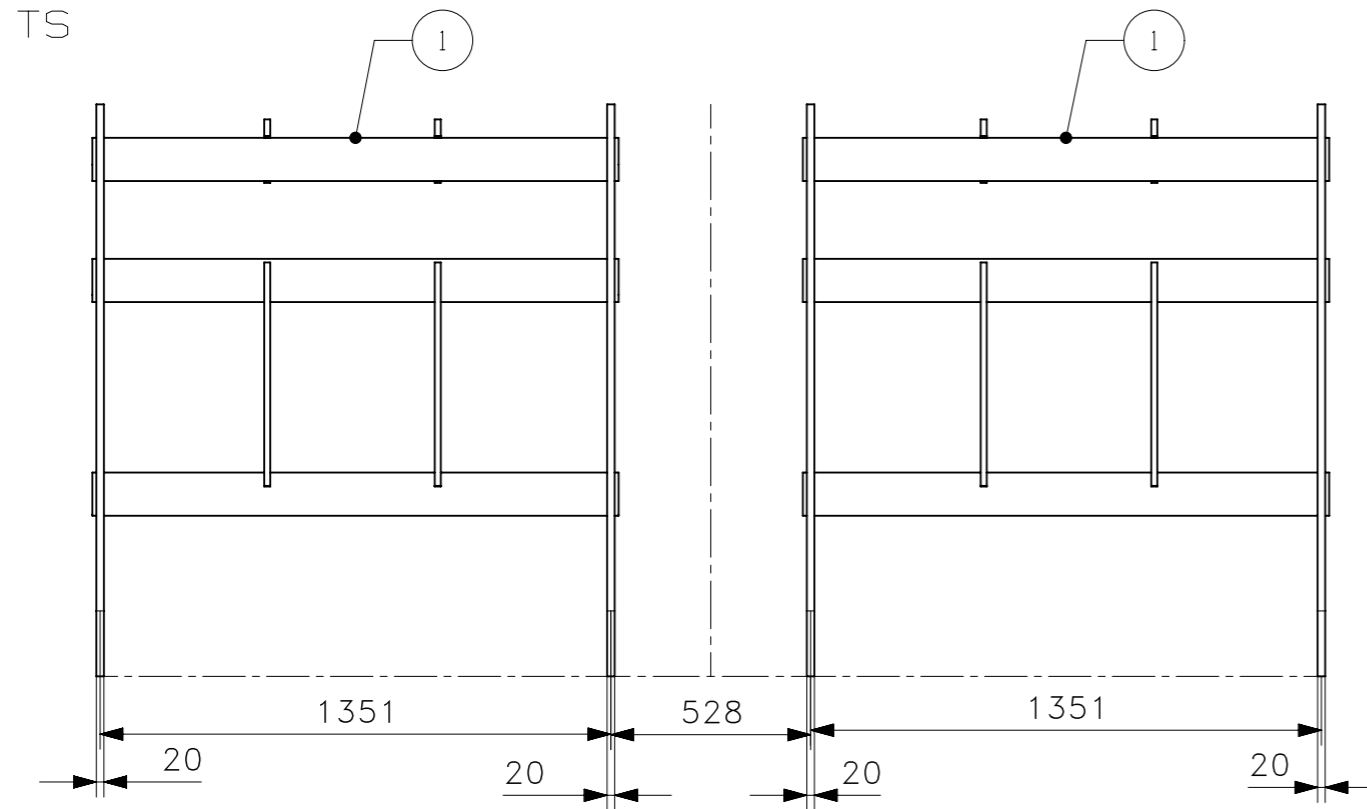

ITEM NO.	DESCRIPTION	DRAWING NO.	VAR. NO.	RAW MATERIAL SIZE OR CASTING DRG. NO. OR FORGING DRG. NO.	MATERIAL CODE	UNIT WT
						1400
						1
					MATERIAL SPECN.	QUANTITY

THE FOLLOWING CONDITIONS APPLY EXCEPT OTHERWISE STATED....

- REF. TO HY0230261 FOR UNSPECIFIED TOLERANCES.
- CHAMFER M/CD. SHARP EDGES 1.2 TO 1.0 AT 45°.
- INTERNAL M/CD. CORNER RADII 1 TO 0.7
- THE SURFACE ROUGHNESS WHEREVER NOT SHOWN SHALL BE TAKEN FROM THE SURFACE ROUGHNESS SHOWN OUT SIDE BACK SLASHES GIVEN AT THE TOP MOST RIGHT CORNER OF THE DRG.

TYPE OF PRODUCT OR NAME OF CUSTOMER/PROJECT
TARI-930-30P

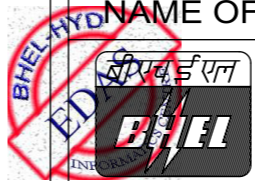

BHARAT HEAVY ELECTRICALS LTD.
HYDERABAD

DRN.	A.PRAMODH	SIGN.	DATE	NO.OF VAR.
CHD.	M.ASIM		28.01.16	NA
APPD.	K.C.PANDA		28.01.16	

DEPT. EME	SCALE N.T.S	WEIGHT (KG) 1400	REF. TO ASSY DRG. 01350131205	ITEM NO. 2	NO.OF ITEMS NA
CODE 425					

TITLE: STATOR FRAME WELDMENT-TOP PART
CARD CODE: NA
DRAWING NO.: 3-135-01-33838
REV.: 00

SCALE: 1:50	DATE: ALTERED	CHECKED/ APPD
ZONE		

INVENTORY NO. SIGN. AND DATE COMP. FILE NAME THE INFORMATION ON THIS DOCUMENT IS THE PROPERTY OF BHARAT HEAVY ELECTRICALS LIMITED.

THE INFORMATION ON THIS DOCUMENT IS THE PROPERTY OF BHARAT HEAVY ELECTRICALS LIMITED. IT MUST NOT BE USED DIRECTLY OR INDIRECTLY IN ANY WAY DETRIMENTAL TO THE INTEREST OF THE COMPANY

DRG. NO. 3-135-01-33839/00

25

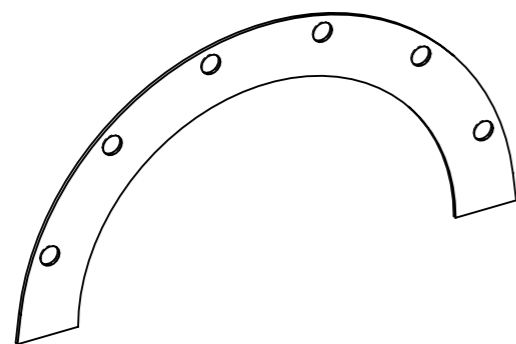
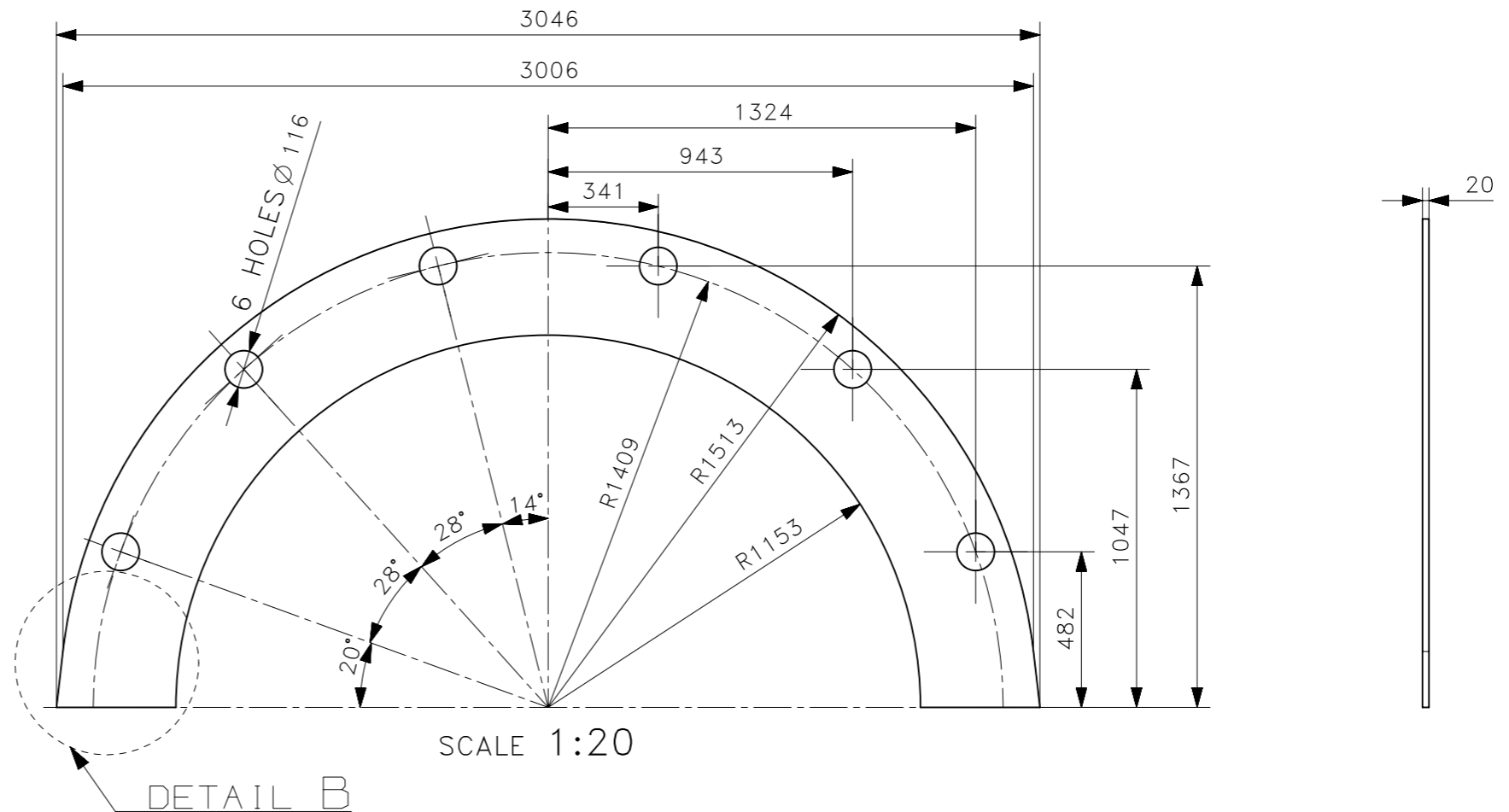
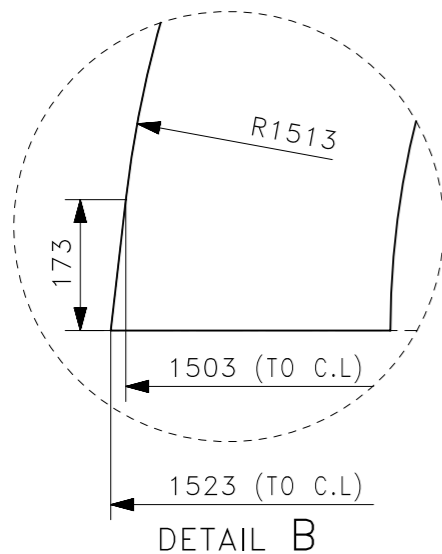

REV.	DATE	ALTERED	CHECKED/ APPD
ZONE			

				PL: 20	AA1011819139	235.30
					AA10119	4
ITEM NO.	DESCRIPTION	DRAWING NO.	VAR. NO.	RAW MATERIAL SIZE OR CASTING DRG. NO. OR FORGING DRG. NO.	MATERIAL CODE	UNIT WT
					MATERIAL SPECN.	QUANTITY
<p>THE FOLLOWING CONDITIONS APPLY EXCEPT OTHERWISE STATED....</p> <ol style="list-style-type: none"> REF. TO HY0230261 FOR UNSPECIFIED TOLERANCES. CHAMFER M/CD. SHARP EDGES 1.2 TO 1.0 AT 45°. INTERNAL M/CD. CORNER RADII 1 TO 0.7 THE SURFACE ROUGHNESS WHEREVER NOT SHOWN SHALL BE TAKEN FROM THE SURFACE ROUGHNESS SHOWN OUT SIDE BACK SLASHES GIVEN AT THE TOP MOST RIGHT CORNER OF THE DRG. 				<p>TYPE OF PRODUCT OR NAME OF CUSTOMER/PROJECT</p> <p>TARI-930-30P</p>		
<p>BHARAT HEAVY ELECTRICALS LTD. HYDERABAD</p>				DEPT. EME	SCALE N.T.S	WEIGHT (KG) 235.30
<p>AIR BAFFLE SHEET</p>				CODE 425	REF. TO ASSY DRG. 21350131327	ITEM NO. 1
<p>NO. OF SHEETS: /</p>				CARD CODE NA	DRAWING NO. 3-135-01-33839	REV. 00

THE INFORMATION ON THIS DOCUMENT IS THE PROPERTY OF BHARAT HEAVY ELECTRICALS LIMITED. IT MUST NOT BE USED DIRECTLY OR INDIRECTLY IN ANY WAY DETRIMENTAL TO THE INTEREST OF THE COMPANY

DRG. NO. 31350133858/00

FIRST ANGLE PROJECTION

(ALL DIMENSIONS ARE IN mm)

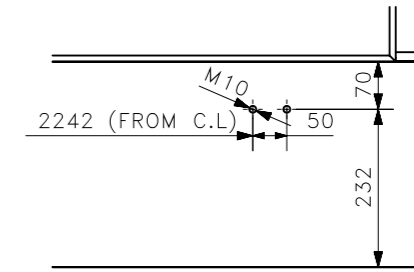
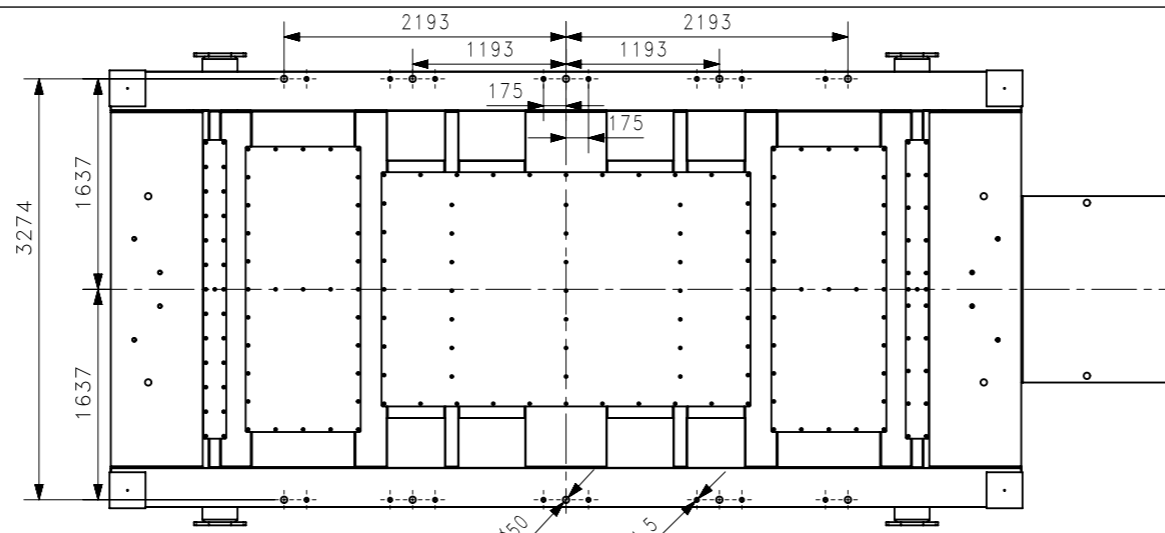
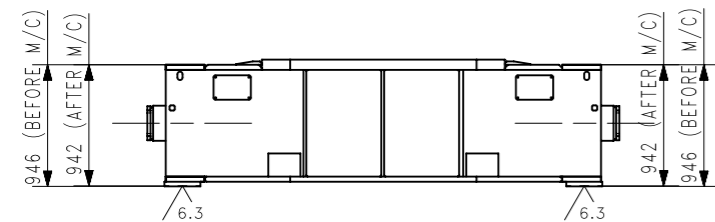

DETAIL A

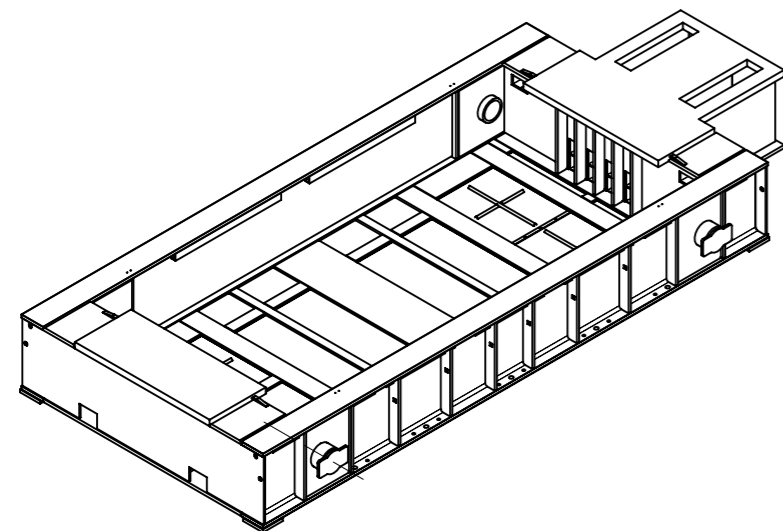
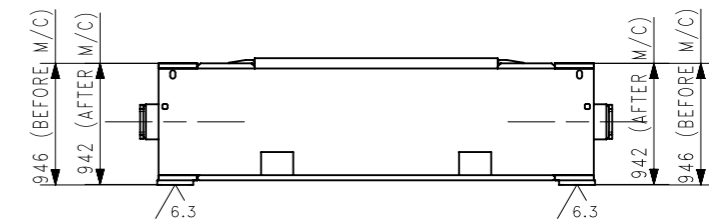
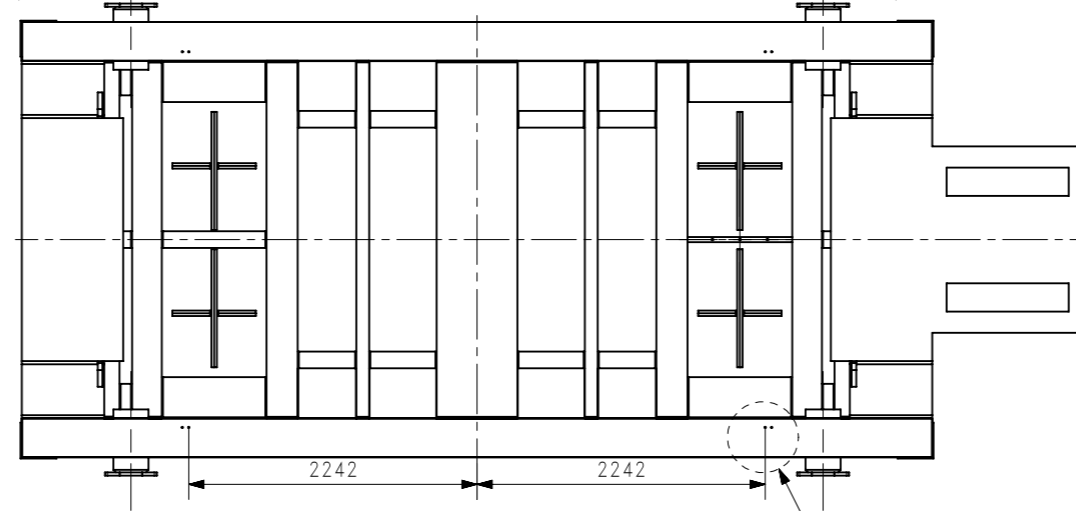
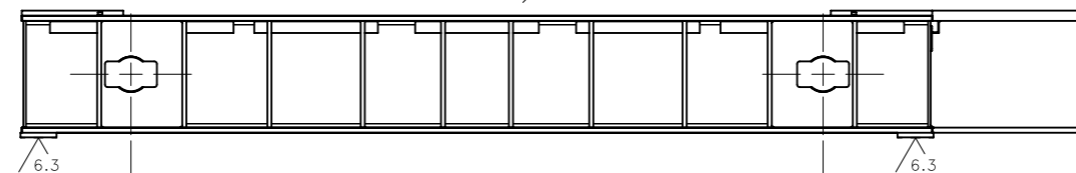

ITEM NO.	DESCRIPTION	DRAWING NO.	VAR. NO.	RAW MATERIAL SIZE OR CASTING DRG. NO. OR FORGING DRG. NO.	MATERIAL CODE	UNIT WT
					MATERIAL SPECN.	QUANTITY
						18832.5
						1

THE FOLLOWING CONDITIONS APPLY EXCEPT OTHERWISE STATED....

- REF. TO HY0230261 FOR UNSPECIFIED TOLERANCES.
- CHAMFER M/CD. SHARP EDGES 1.2 TO 1.0 AT 45°.
- INTERNAL M/CD. CORNER RADII 1 TO 0.7
- THE SURFACE ROUGHNESS WHEREVER NOT SHOWN SHALL BE TAKEN FROM THE SURFACE ROUGHNESS SHOWN OUT SIDE BACK SLASHES GIVEN AT THE TOP MOST RIGHT CORNER OF THE DRG.

TYPE OF PRODUCT OR NAME OF CUSTOMER/PROJECT

TARI 930-30P



BHARAT HEAVY ELECTRICALS LTD. HYDERABAD

NAME	SIGN.	DATE	NO.OF VAR.
DRN. A.PRAMODH		13.01.16	
GHD. M.ASIM		13.01.16	NA
APPD. K.C.PANDA		13.01.16	

REV.	DATE	ALTERED	CHECKED/ APPD

DEPT. EME	SCALE NA	WEIGHT (KG) 18832.5	REF. TO ASSY DRG. 01350131205	ITEM NO. 1	NO.OF ITEMS NA
CODE 425			DRAWING NO. 31350133858		REV. 00
TITLE: BASE FRAME MACHINING			CARD CODE NA	SHEET No.: / NO OF SHEETS: /	

Apr Tue 19 08:19 2016

Printed by : MOHAMMAD ASIM-FME3003 / 6006175 on 04-08-16 09:54:20

This Drawing is printed from Engineering Digital Archive System (EDAS). Therefore signatures are not essentially required.

REV.	DATE	ALTERED	REV.	DATE	ALTERED	REV.	DATE	ALTERED
		CHECKED			CHECKED			CHECKED
		APPROVED			APPROVED			APPROVED

THE INFORMATION ON THIS DOCUMENT IS THE PROPERTY OF BHARAT HEAVY ELECTRICALS LIMITED. IT MUST NOT BE USED DIRECTLY OR INDIRECTLY IN ANY WAY DETRIMENTAL TO THE INTEREST OF THE COMPANY.

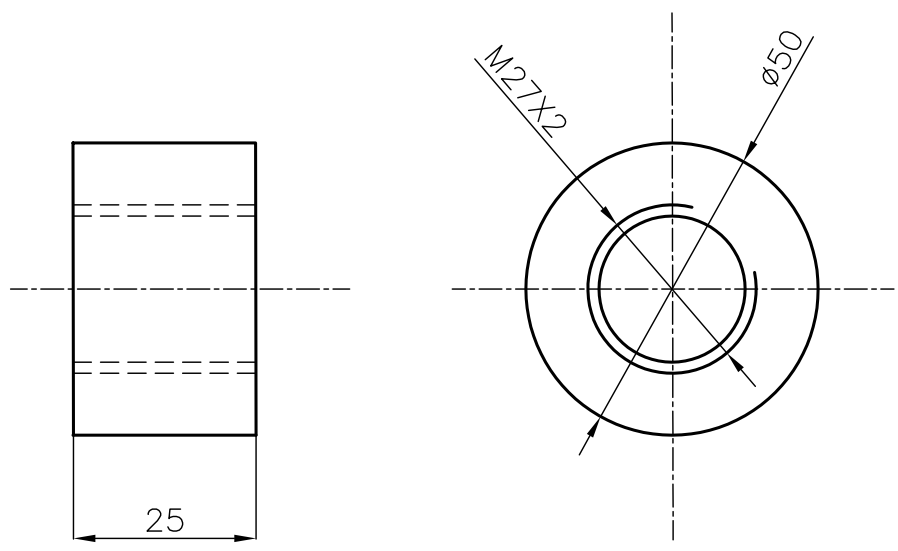

6.5



COMPUTER NO. 44A1427A	BUSH M27X2		R0:50	AA1010208187	0.27	
	4-135-01-31427			AA10108	2	
REF. DRG. NO.	DESCRIPTION & DRG.NO.	VAR NO.	RAW MATERIAL SIZE OR CASTING DRG.NO. OR FORGING DRG.NO.	MATL. CODE	NET.WT.	GROSS WT
				MATL. SPECN.	QTY.	

TYPE OF PRODUCT OR NAME OF CUSTOMER/PROJECT

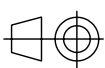

 BHARAT HEAVY ELECTRICALS LTD. HYDERABAD		NAME	SIGN	DATE	NO.OF VAR.
DEPT. EME	 SCALE N.A WEIGHT(K.G.) 0.27	DRN. KCB	 U.SRIDHAR	03.06.03	
CODE 425		CKD. K.C.PANDA		03.06.03	
TITLE		APPD. U.SRIDHAR			03.06.03
REF. TO HY0230 UNSPECIFIED TOL		REF. TO ASSY.DRG. N.A	ITEM NO. N.A	NO.OF ITEM NA	
BUSH M27X2		DRAWING NO. 4-135-01-31427		REV. 00	
		SHT.NO. 01	NO.OF SHT. 01		

REV.	DATE	ALTERED	PDN	REV.	DATE	ALTERED		REV.	DATE	ALTERED
01	14.11.13	CHECKED	KCP			CHECKED				CHECKED
		APPROVED	US			APPROVED				APPROVED

POS NOS SHOWN.

THE INFORMATION ON THIS DOCUMENT IS THE PROPERTY OF BHARAT HEAVY ELECTRICALS LIMITED. IT MUST NOT BE USED DIRECTLY OR INDIRECTLY IN ANY WAY DETRIMENTAL TO THE INTEREST OF THE COMPANY.

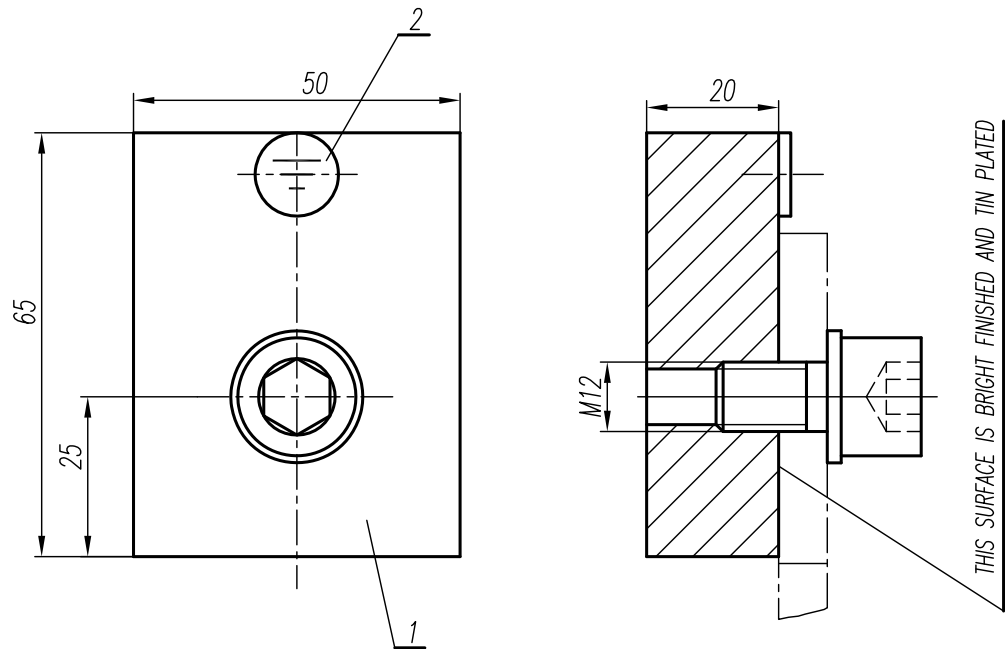

		PL:20	AA 1011819139	0.5	
			AA 10119	1	
DESCRIPTION & DRG.NO.	VAR NO.	RAW MATERIAL SIZE OR CASTING DRG.NO. OR FORGING DRG.NO.	MATL. CODE	NET.WT.	GROSS WT
			MATL. SPECN.	QTY.	

TYPE OF PRODUCT OR NAME OF CUSTOMER/PROJECT **TARI 1080-36Q**

INVENTORY NO. _____

REF. TO HY023026 UNSPECIFIED TOLER

REF. & DATE: 4-117820

COMPUTER NO. _____

DRG. NO. _____

SIGN. & DATE: _____

BHEL-HYD

ELHS

SAP

BHARAT HEAVY ELECTRICALS LTD. HYDERABAD		NAME	SIGN	DATE	NO.OF VAR. NA
DEPT.	EME	DRN.	JCS	19-05-2009	
CODE	425	CKD.	K.C. PANDA	19-05-2009	
TITLE	SCALE NTS WEIGHT(K.G.) 0.5	APPD.	U.SRIDHAR	19-05-2009	NO.OF ITEM NA
			REF.TO ASSY.DRG.	1-14201-31104-00	ITEM NO. 19
GROUND TERMINAL TOTAL		DRAWING NO.	4-135-01-33514		REV. 01
		SHT.NO. 01	NO.OF SHT. 01		

THE INFORMATION ON THIS DOCUMENT IS THE PROPERTY OF BHARAT HEAVY ELECTRICALS LIMITED. IT MUST NOT BE USED DIRECTLY OR INDIRECTLY IN ANY WAY DETRIMENTAL TO THE INTEREST OF THE COMPANY.

REV.	DATE	ALTERED	REV.	DATE	ALTERED	REV.	DATE	ALTERED
		CHECKED			CHECKED			CHECKED
		APPROVED			APPROVED			APPROVED

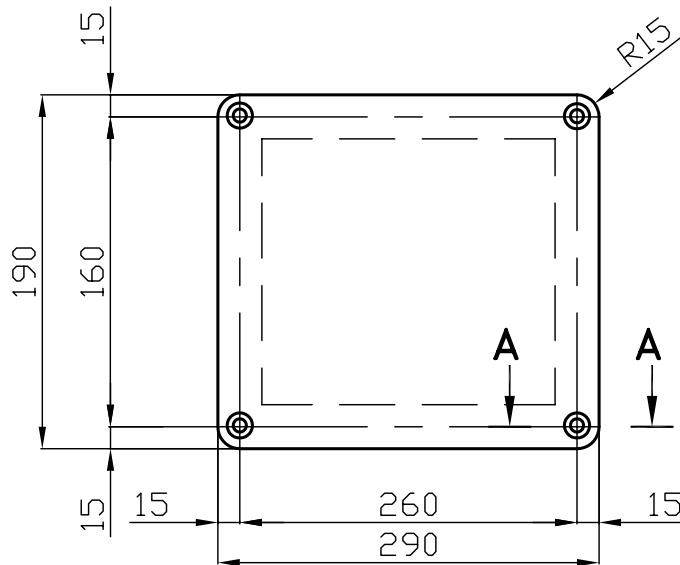

25/

SECTION A-A

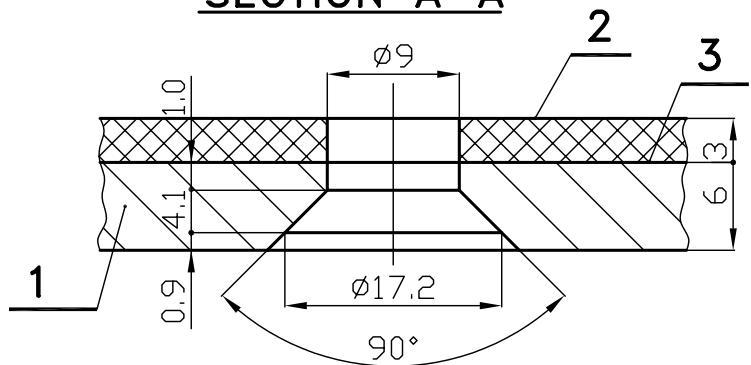

COMPUTER NO.	COVER 4-135-01-33629	ASSEMBLY	3.0
REF. DRG. NO.	DESCRIPTION & DRG.NO.	MATL. CODE	NET.WT. GROSS WT.
	VAR NO.	MATL. SPECN.	QTY.

TYPE OF PRODUCT OR NAME OF CUSTOMER/PROJECT: TARI 1080-36Q

INVENTORY NO. REF. TO HY0230 UNSPECIFIED TO	DEPT. EME CODE 425		SCALE NTS	WEIGHT(K.G.) 3.0	NAME	SIGN	DATE	NO.OF VAR. NA
					DRN. A.K.SINHA		23.09.10	
					CKD. K.C.PANDA		23.09.10	
					APPD. U.SRIDHA		23.09.10	
TITLE: COVER					REF.TO ASSY.DRG.	ITEM NO.	NO.OF ITEM 1-3	
					DRAWING NO. 4-135-01-33629		REV. 00	
					SHT.NO. 01	NO.OF SHT. 01		

RESTRICTED USE

THE INFORMATION ON THIS DOCUMENT IS THE PROPERTY OF BHARAT HEAVY ELECTRICALS LIMITED. IT MUST NOT BE USED DIRECTLY OR INDIRECTLY IN ANY WAY DETRIMENTAL TO THE INTEREST OF THE COMPANY.

REV.	DATE	ALTERED	KBE	REV.	DATE	ALTERED		REV.	DATE	ALTERED
01	11.08.15	CHECKED	PDN			CHECKED				CHECKED
		APPROVED	US			APPROVED				APPROVED

VARIANT NUMBER DETAILS UPDATED.

25 ✓

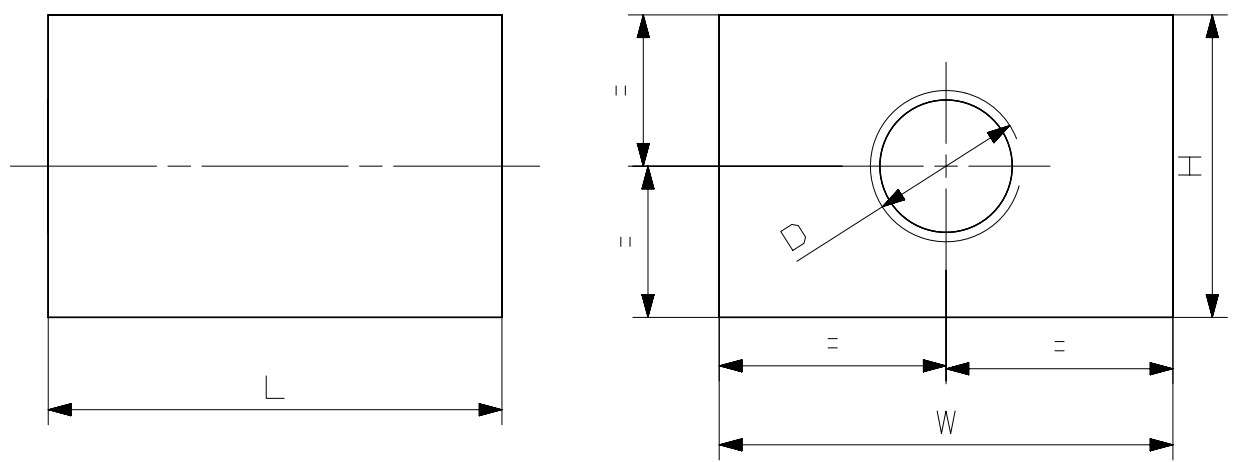

VAR NO.	W	L	H	D	PLATE	MATERIAL CODE	Wt. KG.
01	40	40	25	M12X1.75	25	AA1011819155	0.29
02	50	50	32	M16X2.0	32	AA1011819171	0.58
03	60	60	40	M20X2.5	40	AA1011819198	1.03

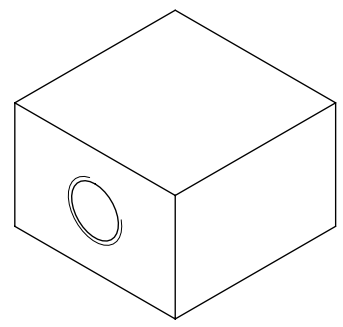

DESCRIPTION & DRG.NO.	VAR NO.	SEE TABLE	SEE TABLE	TABLE	REF. BOM
		RAW MATERIAL SIZE OR CASTING DRG.NO. OR FORGING DRG.NO.	MATL. CODE	NET.WT.	GROSS WT
			MATL. SPECN.	QTY.	

TYPE OF PRODUCT OR NAME OF CUSTOMER/PROJECT **TARI-860-21P**

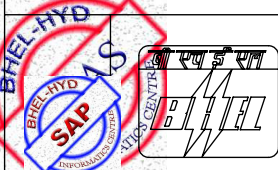

BHARAT HEAVY ELECTRICALS LTD. HYDERABAD

	NAME	SIGN	DATE	NO.OF VAR.
DRN.	K.B.E		22.01.2015	
CKD.	G.C.S.REDDY		22.01.2015	NA
APPD.	U. SRIDHAR		22.01.2015	

DEPT. EME	SCALE N.T.S	WEIGHT(K.G.) SEE TABLE	REF.TO ASSY.DRG. REF. BOM	ITEM NO. 170	NO.OF ITEM NA
CODE 425					

TITLE **AIR GUIDE RING SUPPORT PLATE** DRAWING NO. **4-135-01-33959** REV. **01**

THE INFORMATION ON THIS DOCUMENT IS THE PROPERTY OF BHARAT HEAVY ELECTRICALS LIMITED. IT MUST NOT BE USED DIRECTLY OR INDIRECTLY IN ANY WAY DETRIMENTAL TO THE INTEREST OF THE COMPANY.

REV.	DATE	ALTERED	KBE	REV.	DATE	ALTERED		REV.	DATE	ALTERED
01	11.08.15	CHECKED	PDN			CHECKED				CHECKED
		APPROVED	US			APPROVED				APPROVED

VARIANT DETAILS UPDATED.

25 ✓

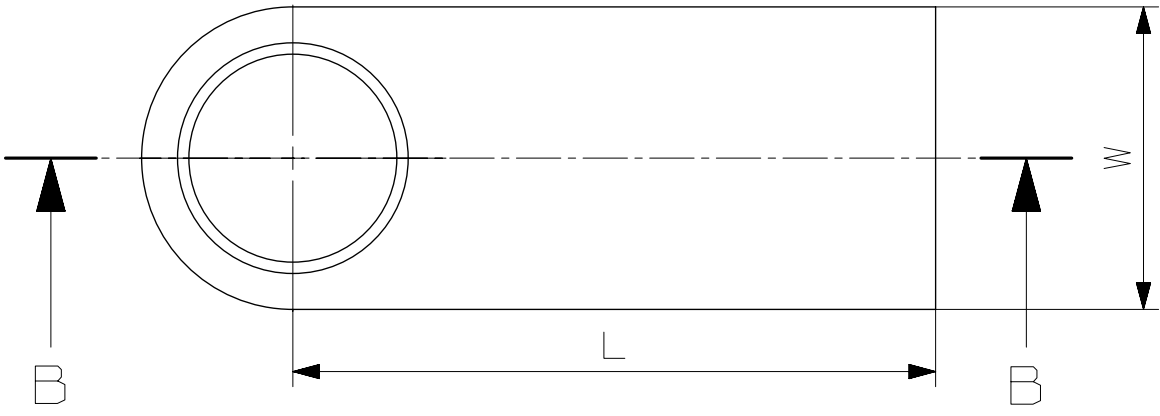
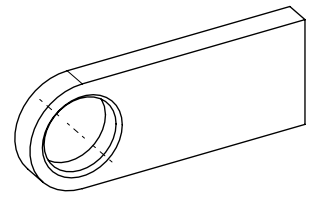
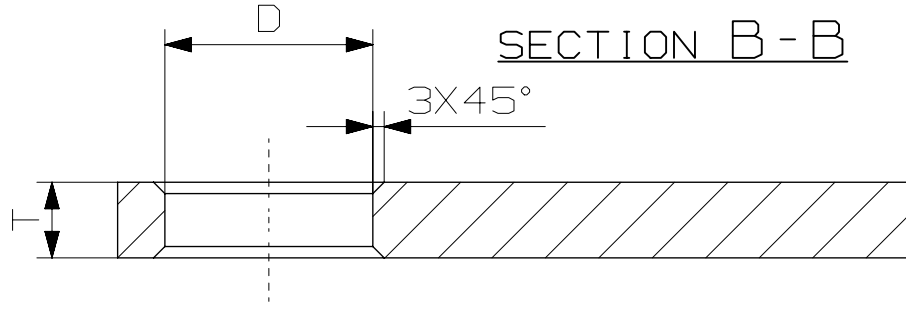

VAR NO.	PIPE SIZE	T	W	L	D	MATERIAL CODE	Wt.
01	1"	12	65	140	36	AA1011819090	0.966
02	1 1/2"	16	80	170	55	AA1011819112	1.88
03	2"	20	90	200	65	AA1011819139	3.07

		SEE TABLE	SEE TABLE	TABLE	
			REF. BOM	REF. BOM	
DESCRIPTION & DRG.NO.	VAR NO.	RAW MATERIAL SIZE OR CASTING DRG.NO. OR FORGING DRG.NO.	MATL. CODE	NET.WT.	GROSS WT
			MATL. SPECN.	QTY.	

TYPE OF PRODUCT OR NAME OF CUSTOMER/PROJECT

TARI-860-21P

BHARAT HEAVY ELECTRICALS LTD.
HYDERABAD

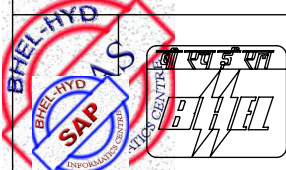

	NAME	SIGN	DATE	NO.OF VAR.
DRN.	K.B.E		22.01.2015	
CKD.	G.C.S.REDDY		22.01.2015	NA
APPD.	U. SRIDHAR		22.01.2015	

DEPT. EME		SCALE N.T.S	WEIGHT(K.G.) SEE TABLE	REF.TO ASSY.DRG. REF. BOM	ITEM NO. 150	NO.OF ITEM NA
-----------	--	-------------	------------------------	---------------------------	--------------	---------------

TITLE	DRAWING NO.	REV.
AIR SEAL PIPE HOLDER	4-135-01-33960	01

REF. TO HY023026 UNSPECIFIED TOLERANCE

THE INFORMATION ON THIS DOCUMENT IS THE PROPERTY OF BHARAT HEAVY ELECTRICALS LIMITED. IT MUST NOT BE USED DIRECTLY OR INDIRECTLY IN ANY WAY DETRIMENTAL TO THE INTEREST OF THE COMPANY.

REV.	DATE	ALTERED	REV.	DATE	ALTERED	REV.	DATE	ALTERED
		CHECKED			CHECKED			CHECKED
		APPROVED			APPROVED			APPROVED

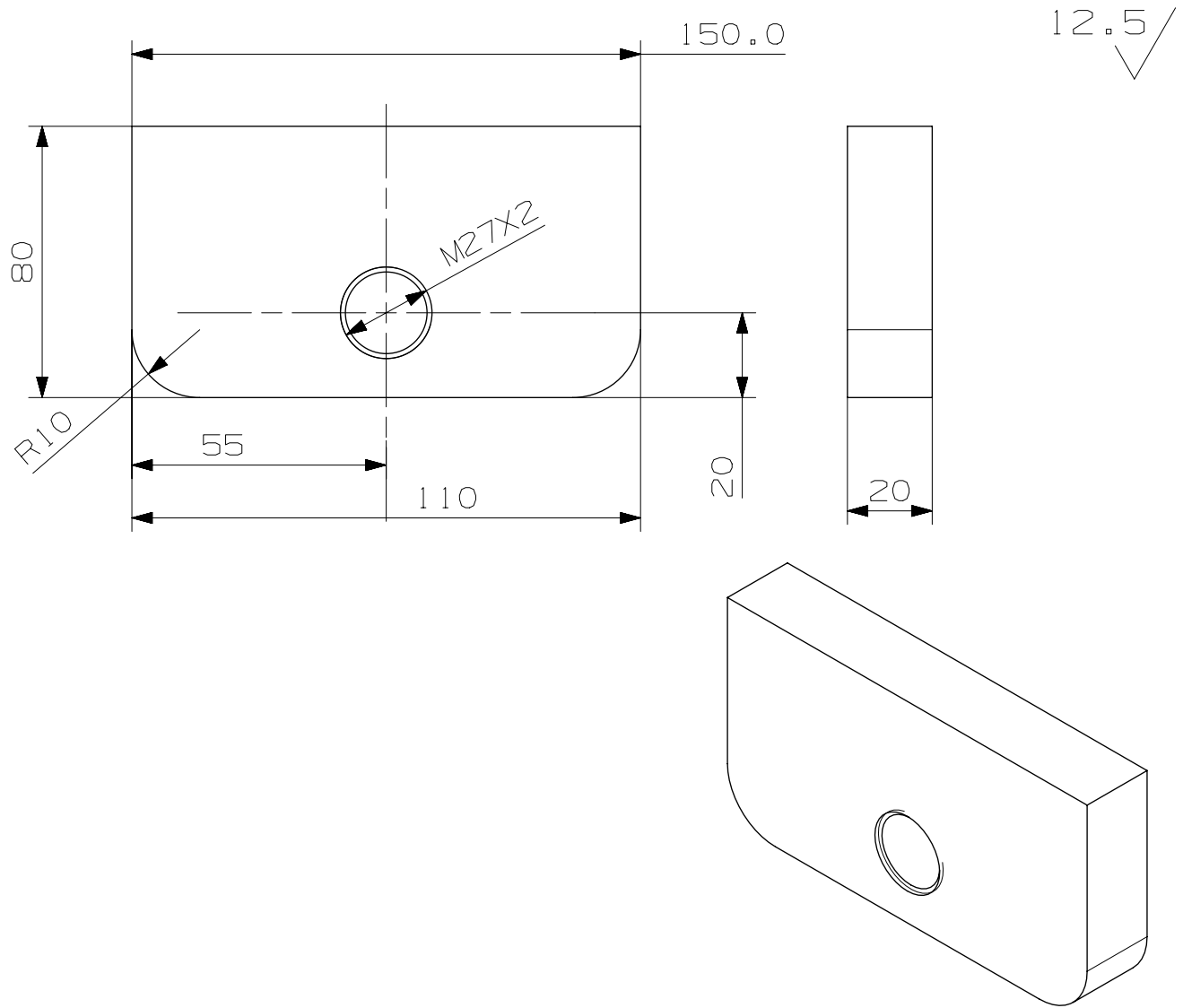

		PL: 20	AA1011819139	1.38	
			AA10119	8	
DESCRIPTION & DRG.NO.	VAR NO.	RAW MATERIAL SIZE OR CASTING DRG.NO. OR FORGING DRG.NO.	MATL. CODE	NET.WT.	GROSS WT
			MATL. SPECN.	QTY.	

TYPE OF PRODUCT OR NAME OF CUSTOMER/PROJECT: TARI-860-21P

	BHARAT HEAVY ELECTRICALS LTD. HYDERABAD			NAME	SIGN	DATE	
	DRN.	KBE		RESERVED		22.01.2015	NO.OF VAR.
	CKD.	GCS REDDY				22.01.2015	NA
APPD.	U SRIDHAR				22.01.2015	NA	

DEPT. EME		SCALE NTS	WEIGHT(K.G.) 1.38	REF.TO ASSY.DRG. REF. BOM	ITEM NO. 170	NO.OF ITEM NA
CODE 425						
TITLE RTD MOUNTING PLATE				DRAWING NO. 4-135-01-33962	REV. 00	

THE INFORMATION ON THIS DOCUMENT IS THE PROPERTY OF BHARAT HEAVY ELECTRICALS LIMITED. IT MUST NOT BE USED DIRECTLY OR INDIRECTLY IN ANY WAY DETRIMENTAL TO THE INTEREST OF THE COMPANY.

REV.	DATE	ALTERED	REV.	DATE	ALTERED	REV.	DATE	ALTERED
		CHECKED			CHECKED			CHECKED
		APPROVED			APPROVED			APPROVED

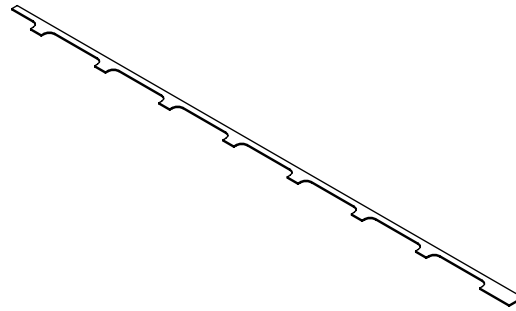
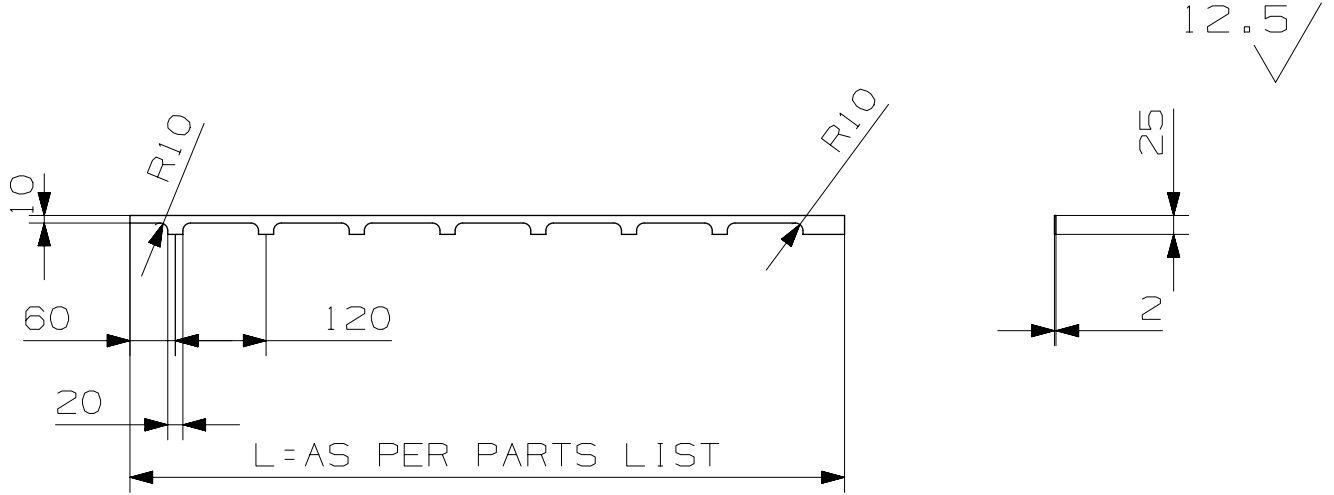

* ADAPT SUITABLY AS PER DRAWING NUMBER 21350131324

DESCRIPTION & DRG.NO.	VAR NO.	SH: 2	AA1011711117	10.00	
			AA10111	1	
		RAW MATERIAL SIZE OR CASTING DRG.NO. OR FORGING DRG.NO.	MATL. CODE	NET.WT.	GROSS WT
			MATL. SPECN.	QTY.	

TYPE OF PRODUCT OR NAME OF CUSTOMER/PROJECT

TARI-860-21P

	BHARAT HEAVY ELECTRICALS LTD. HYDERABAD		NAME	SIGN	DATE	NO.OF VAR. NA
	DRN.	K.B.E	AS PER LISTED		13.02.15	
	CKD.	GCS REDDY			13.02.15	
APPD.	U SRIDHAR			13.02.15		
DEPT. EME		SCALE NTS	WEIGHT(K.G.) 10.00	REF.TO ASSY.DRG. REF. BOM	ITEM NO. 10	NO.OF ITEM NA
CODE 425						
TITLE				DRAWING NO.		REV.
WEBBED STRIP FOR WIRING				4-135-01-34016		00

REF. TO HY023026 UNSPECIFIED TOLERANCES

THE INFORMATION ON THIS DOCUMENT IS THE PROPERTY OF BHARAT HEAVY ELECTRICALS LIMITED. IT MUST NOT BE USED DIRECTLY OR INDIRECTLY IN ANY WAY DETRIMENTAL TO THE INTEREST OF THE COMPANY.

25 ✓

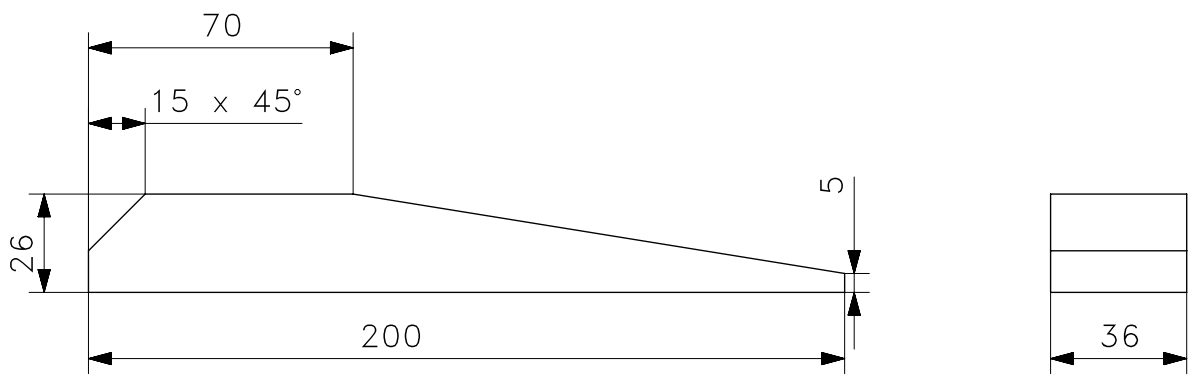

SCALE 1:2

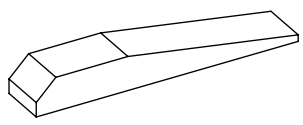

DESCRIPTION & DRG.NO.	VAR NO.	PL: 36	AA1011819180	1.10	
			AA10119	4	
		RAW MATERIAL SIZE OR CASTING DRG.NO. OR FORGING DRG.NO.	MATL. CODE	NET.WT.	GROSS WT
			MATL. SPECN.	QTY.	

TYPE OF PRODUCT OR NAME OF CUSTOMER/PROJECT: TARI-930-30P

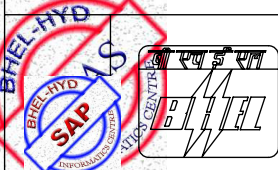

BHARAT HEAVY ELECTRICALS LTD. HYDERABAD

	NAME	SIGN	DATE	NO.OF VAR.
DRN.	A. PRAMODH		22.01.16	
CKD.	M.ASIM		22.01.16	
APPD.	K.C.PANDA		22.01.16	NA

REF. TO HY023026 UNSPECIFIED TOLERANCE

DEPT. EME		SCALE N.T.S	WEIGHT(K.G.) 1.10	REF.TO ASSY.DRG. 01350131206	ITEM NO. 39	NO.OF ITEM NA
CODE 425						

TITLE	DRAWING NO.	REV.
ENCLOSURE SEALING STAND CLOSING PLATE	4-135-01-34064	00

THE INFORMATION ON THIS DOCUMENT IS THE PROPERTY OF BHARAT HEAVY ELECTRICALS LIMITED. IT MUST NOT BE USED DIRECTLY OR INDIRECTLY IN ANY WAY DETRIMENTAL TO THE INTEREST OF THE COMPANY.

REV.	DATE	ALTERED	REV.	DATE	ALTERED	REV.	DATE	ALTERED
		CHECKED			CHECKED			CHECKED
		APPROVED			APPROVED			APPROVED

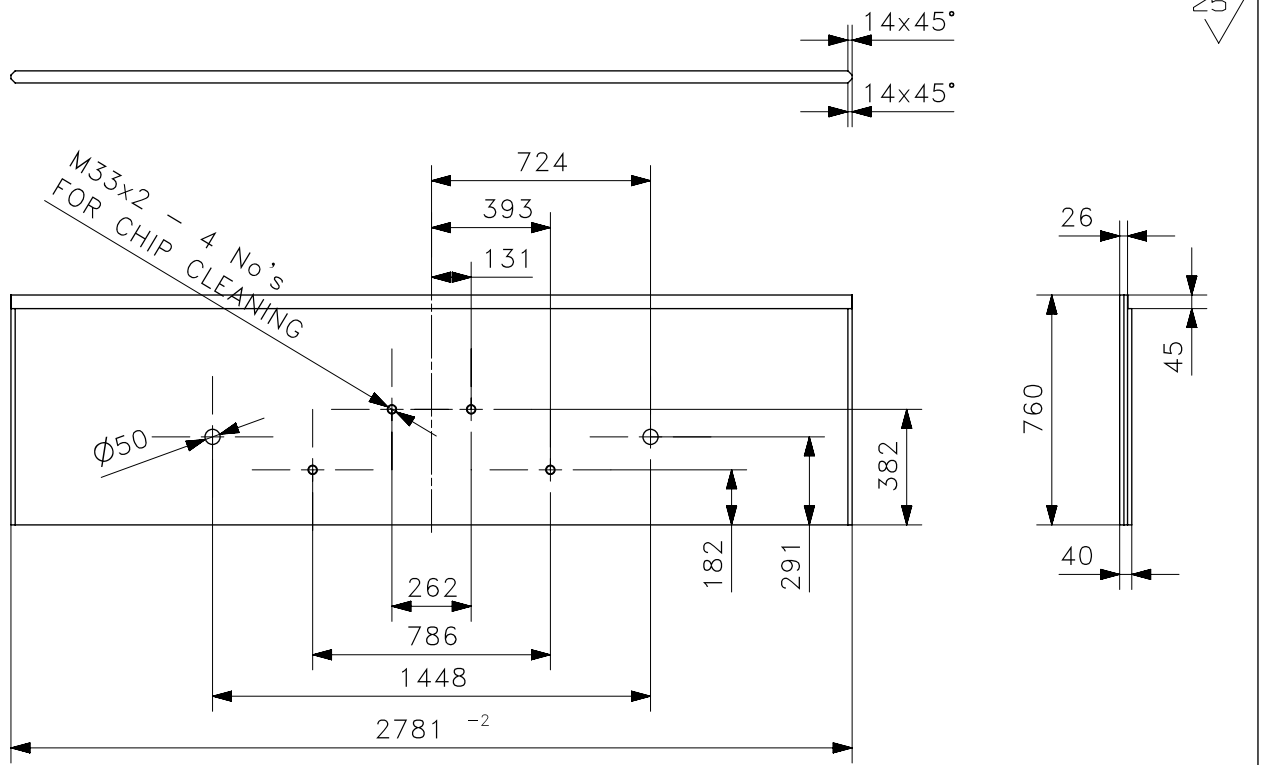

INVENTORY NO.	SIGN. & DATE	REF. DRG. NO.	COMPUTER NO.	PL: 40	AA1011819198	644.80	
					AA10119	2	
DESCRIPTION & DRG.NO.	VAR NO.	RAW MATERIAL SIZE OR CASTING DRG.NO. OR FORGING DRG.NO.		MATL. CODE	NET.WT.	GROSS WT	
				MATL. SPECN.	QTY.		

TYPE OF PRODUCT OR NAME OF CUSTOMER/PROJECT

TARI-930-30P

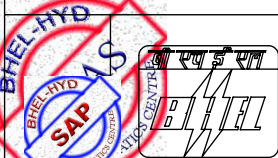

BHARAT HEAVY ELECTRICALS LTD. HYDERABAD

	NAME	SIGN	DATE	NO.OF VAR. NA
DRN.	A.PRAMODH		22.01.16	
CKD.	M.ASIM		22.01.16	
APPD.	K.C.PANDA		22.01.16	

DEPT. EME		SCALE N.T.S	WEIGHT(K.G.) 644.80	REF.TO ASSY.DRG. 01350131206	ITEM NO. 3	NO.OF ITEM NA
CODE 425						

TITLE TS & ES BOTTOM MOUNTING PLATE BELOW BRG	DRAWING NO. 4-135-01-34065	REV. 00
---	----------------------------	---------

THE INFORMATION ON THIS DOCUMENT IS THE PROPERTY OF BHARAT HEAVY ELECTRICALS LIMITED. IT MUST NOT BE USED DIRECTLY OR INDIRECTLY IN ANY WAY DETRIMENTAL TO THE INTEREST OF THE COMPANY.

REV.	DATE	ALTERED	REV.	DATE	ALTERED	REV.	DATE	ALTERED
		CHECKED			CHECKED			CHECKED
		APPROVED			APPROVED			APPROVED

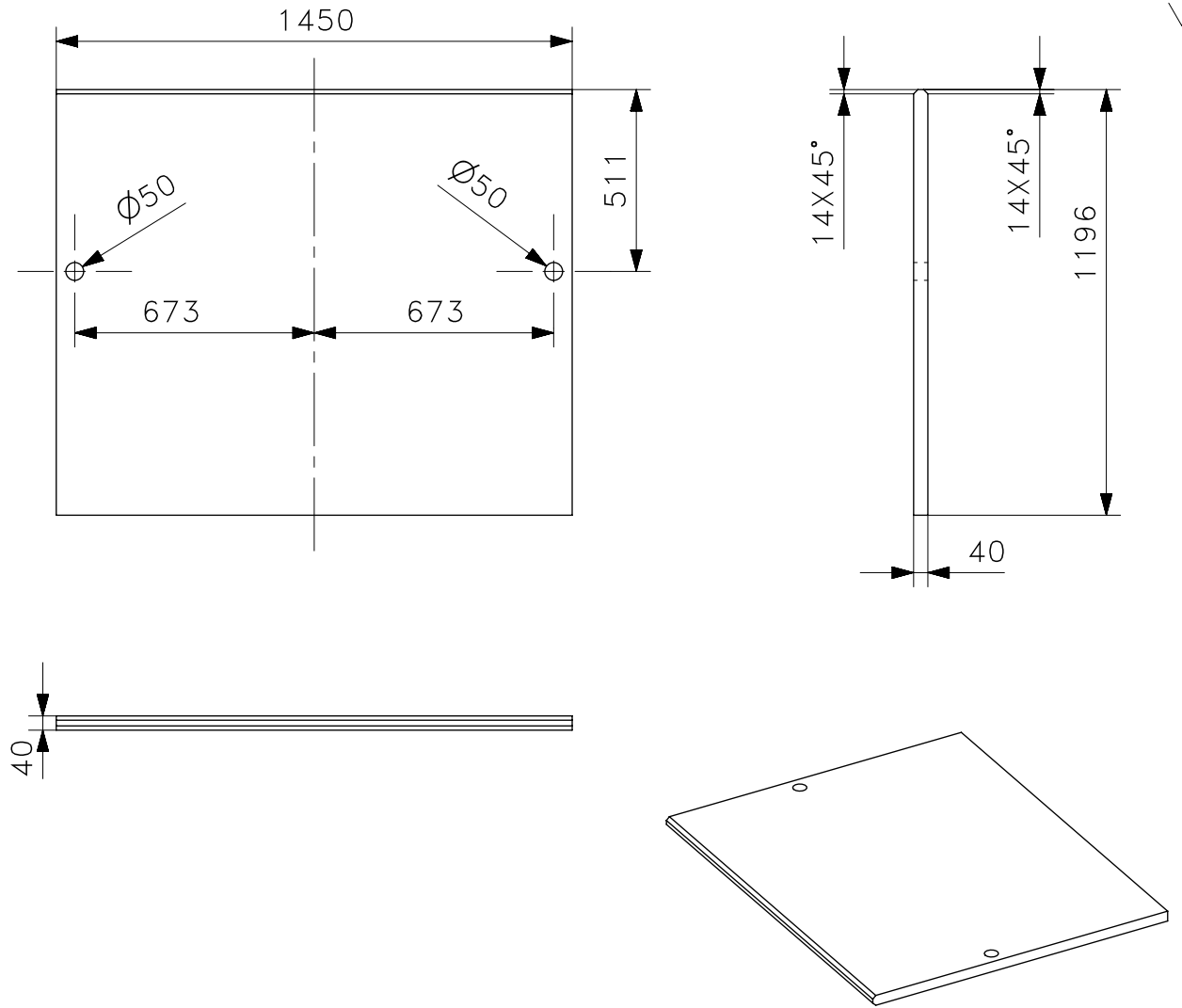

DESCRIPTION & DRG.NO.	VAR NO.	PL: 40	AA1011819198	540.5	
			AA10119	1	
		RAW MATERIAL SIZE OR CASTING DRG.NO. OR FORGING DRG.NO.	MATL. CODE	NET.WT.	GROSS WT
			MATL. SPECN.	QTY.	

TYPE OF PRODUCT OR NAME OF CUSTOMER/PROJECT: TARI-930-30P



BHARAT HEAVY ELECTRICALS LTD. HYDERABAD

	NAME	SIGN	DATE	NO.OF VAR.
DRN.	A.PRAMODH		22.01.16	
CKD.	M.ASIM		22.01.16	NA
APPD.	K.C.PANDA		22.01.16	

DEPT. EME		SCALE N.T.S	WEIGHT(K.G.) 540.5	REF.TO ASSY.DRG. 01350131206	ITEM NO. 4	NO.OF ITEM NA
CODE 425						
TITLE: BOTTOM MOUNTING BELOW EXCITER				DRAWING NO. 4-135-01-34066		REV. 00

Apr Fri 15 08:01 2016

THE INFORMATION ON THIS DOCUMENT IS THE PROPERTY OF BHARAT HEAVY ELECTRICALS LIMITED. IT MUST NOT BE USED DIRECTLY OR INDIRECTLY IN ANY WAY DETRIMENTAL TO THE INTEREST OF THE COMPANY.

INVENTORY NO. SIGN. & DATE REF. DRG. NO. COMPUTER NO.

REV.	DATE	ALTERED	REV.	DATE	ALTERED	REV.	DATE	ALTERED
		CHECKED			CHECKED			CHECKED
		APPROVED			APPROVED			APPROVED

25 ✓

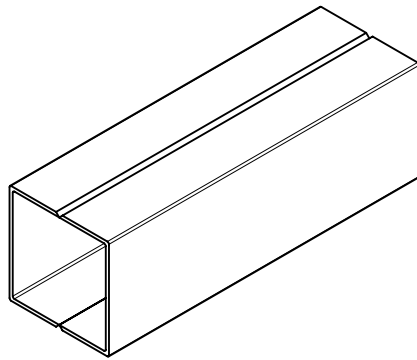
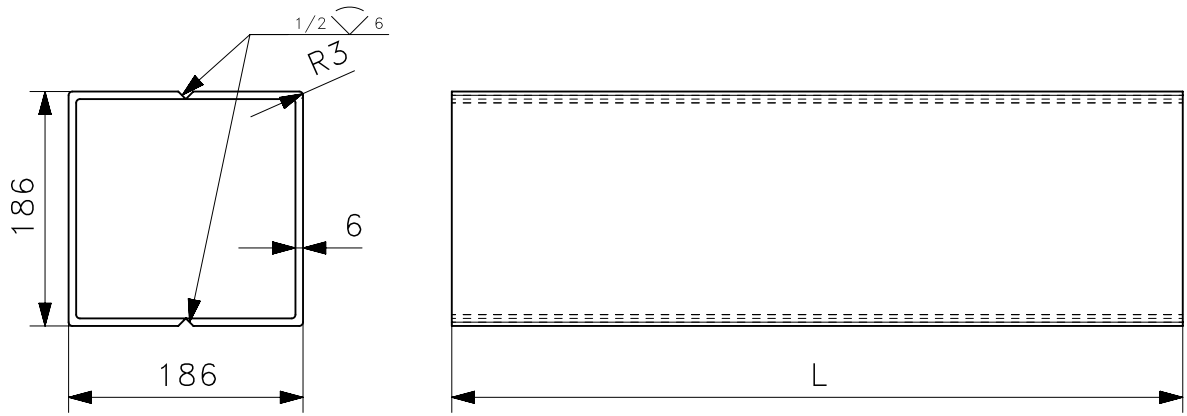

VAR. NO.	L (MM.)	ASSY. DRG NO.	QTY.	MASS (KG.)	POS. NO.
01	580	01350131206	8	19.3	36
02	429	01350131205	4	14.26	14

		PL: 6	AA1011808030	REF. TABLE	
			AA10108	REF. TABLE	
DESCRIPTION & DRG.NO.	VAR NO.	RAW MATERIAL SIZE OR CASTING DRG.NO. OR FORGING DRG.NO.	MATL. CODE	NET.WT.	GROSS WT
			MATL. SPECN.	QTY.	

TYPE OF PRODUCT OR NAME OF CUSTOMER/PROJECT: TARI 930-30P

	BHARAT HEAVY ELECTRICALS LTD. HYDERABAD		NAME	SIGN	DATE	NO.OF VAR. NA
	DRN.		A.PRAMODH	RESERVED	14.01.16	
	CKD.		M.ASIM		14.01.16	
APPD.		K.C.PANDA	14.01.16			
DEPT. EME		SCALE N.T.S	WEIGHT(K.G.) REF. TABLE	REF.TO ASSY.DRG. REF. TABLE	ITEM NO. REF. TABLE	NO.OF ITEM NA
CODE 425						
TITLE: EXCITER AIR DUCTS IN STATOR FRAME			DRAWING NO. 41350134067			REV. 00

THE INFORMATION ON THIS DOCUMENT IS THE PROPERTY OF BHARAT HEAVY ELECTRICALS LIMITED. IT MUST NOT BE USED DIRECTLY OR INDIRECTLY IN ANY WAY DETRIMENTAL TO THE INTEREST OF THE COMPANY.

25 ✓

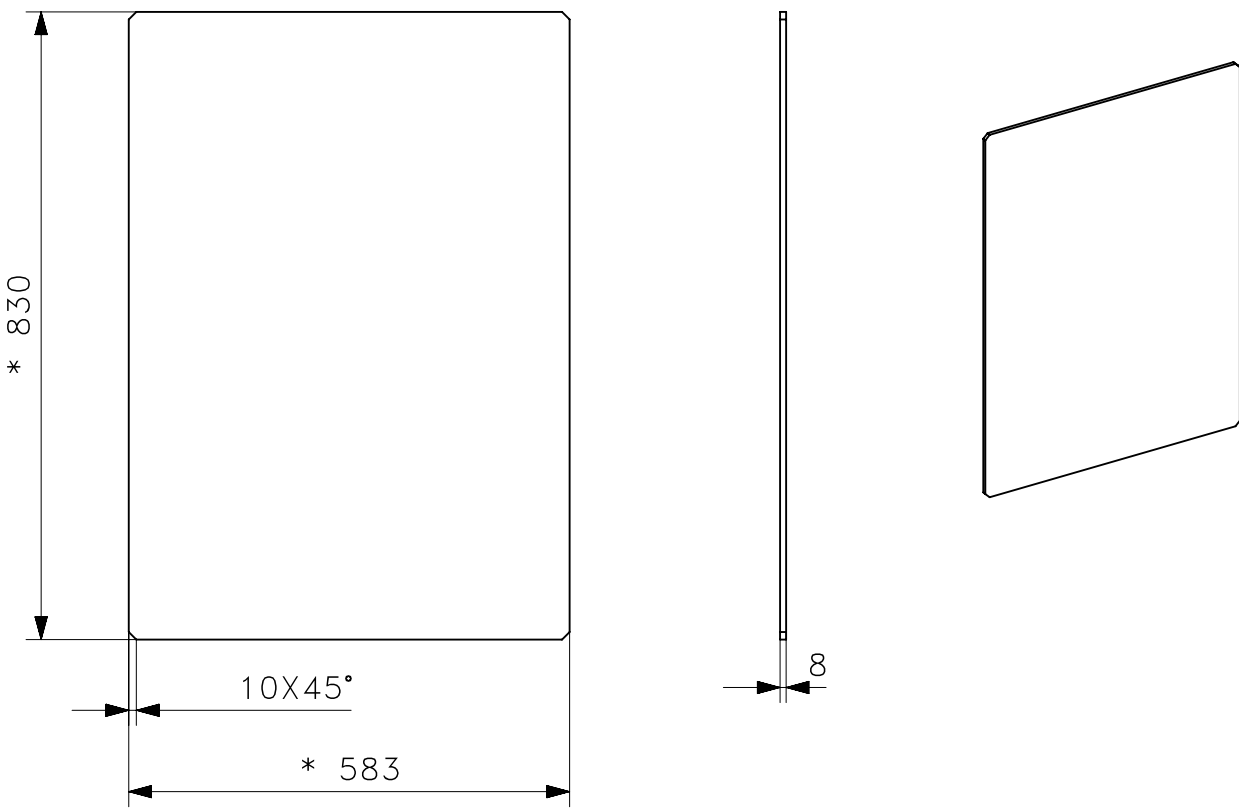

* ADAPT SUITABLY

PL: 8	AA1011808056	30.31	
	AA10108	2	
DESCRIPTION & DRG.NO.	VAR NO.	RAW MATERIAL SIZE OR CASTING DRG.NO. OR FORGING DRG.NO.	MATL. CODE
			NET.WT. GROSS WT
			MATL. SPECN. QTY.

TYPE OF PRODUCT OR NAME OF CUSTOMER/PROJECT: TARI-930-30P

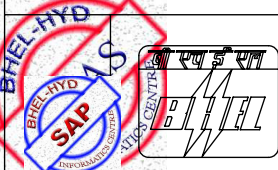

BHARAT HEAVY ELECTRICALS LTD. HYDERABAD

	NAME	SIGN	DATE	NO.OF VAR.
DRN.	A.PRAMODH		22.01.16	
CKD.	M.ASIM		22.01.16	
APPD.	K.C.PANDA		22.01.16	NA

REF. TO HY023026 UNSPECIFIED TOLERANCE

DEPT. EME		SCALE N.T.S	WEIGHT(K.G.) 30.31	REF.TO ASSY.DRG. 01350131206	ITEM NO. 40	NO.OF ITEM NA
CODE 425						

TITLE	DRAWING NO.	REV.
EXCITER END CLOSING PLT	4-135-01-34068	00

THE INFORMATION ON THIS DOCUMENT IS THE PROPERTY OF BHARAT HEAVY ELECTRICALS LIMITED. IT MUST NOT BE USED DIRECTLY OR INDIRECTLY IN ANY WAY DETRIMENTAL TO THE INTEREST OF THE COMPANY.

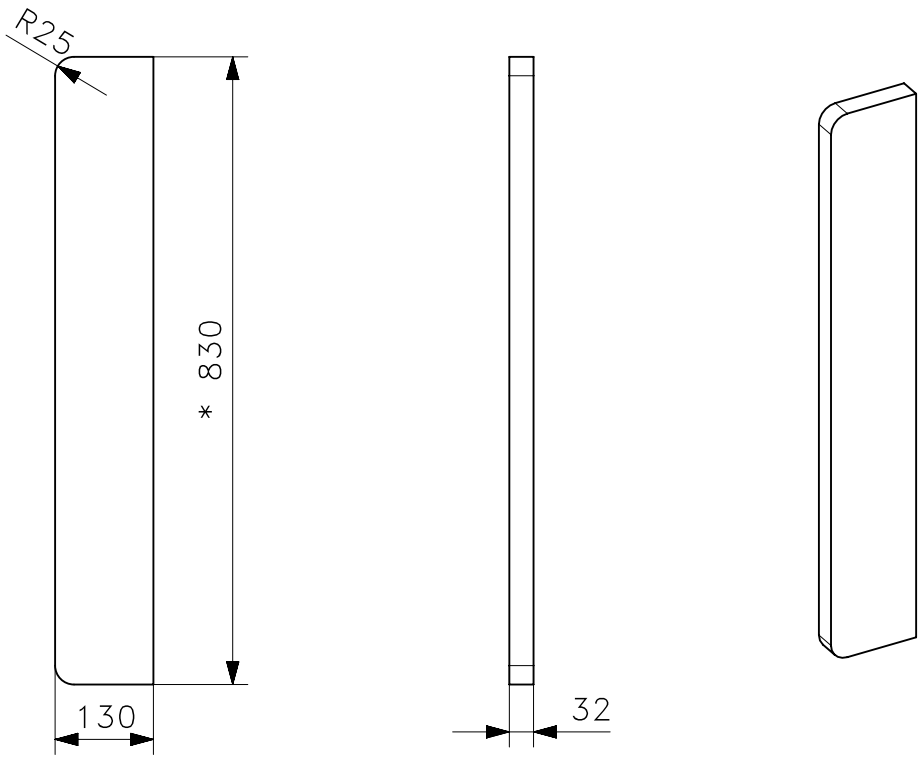

25 ✓



*ADAPT DURING ASSEMBLY.

DESCRIPTION & DRG.NO.	VAR NO.	PL: 32	AA1011819171	26.94	
			AA10119	4	
		RAW MATERIAL SIZE OR CASTING DRG.NO. OR FORGING DRG.NO.	MATL. CODE	NET.WT.	GROSS WT
			MATL. SPECN.	QTY.	

TYPE OF PRODUCT OR NAME OF CUSTOMER/PROJECT: TARI-930-30P

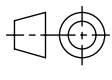
 	BHARAT HEAVY ELECTRICALS LTD. HYDERABAD		NAME	SIGN	DATE	NO.OF VAR.	
	DRN.	A.PRAMODH	RESERVED		22.01.16		NO
	CKD.	M.ASIM			22.01.16		NA
APPD.	K.C.PANDA			22.01.16			
DEPT. EME		SCALE N.T.S	WEIGHT(K.G.) 26.94	REF.TO ASSY.DRG. 01350131206	ITEM NO. 7	NO.OF ITEM NA	
CODE 425							
TITLE I-BEAM INBOARD STIFFENER				DRAWING NO. 4-135-01-34069	REV. 00		

THE INFORMATION ON THIS DOCUMENT IS THE PROPERTY OF BHARAT HEAVY ELECTRICALS LIMITED. IT MUST NOT BE USED DIRECTLY OR INDIRECTLY IN ANY WAY DETRIMENTAL TO THE INTEREST OF THE COMPANY.

25 ✓

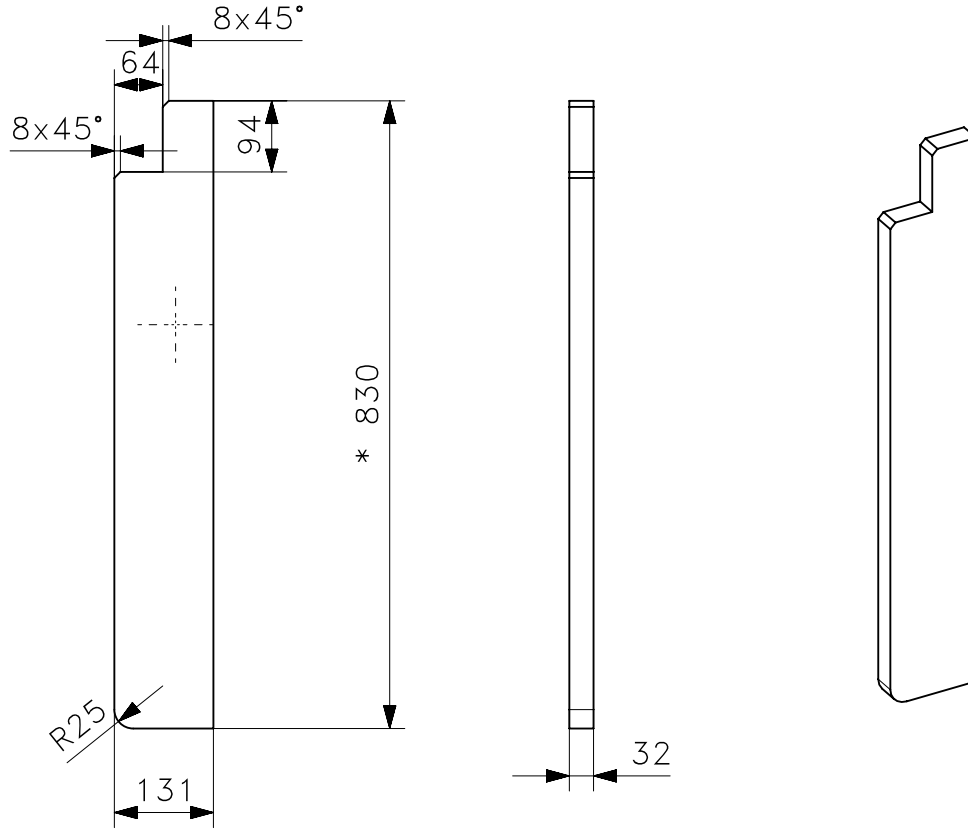

*ADAPT DURING ASSEMBLY.

DESCRIPTION & DRG.NO.	VAR NO.	PL: 32	AA1011819171	25.46	
			AA10119	8	
		RAW MATERIAL SIZE OR CASTING DRG.NO. OR FORGING DRG.NO.	MATL. CODE	NET.WT.	GROSS WT
			MATL. SPECN.	QTY.	

TYPE OF PRODUCT OR NAME OF CUSTOMER/PROJECT: TARI-930-30P

	BHARAT HEAVY ELECTRICALS LTD. HYDERABAD		NAME	SIGN	DATE	NO.OF VAR.	
	DRN.	A.PRAMODH	RESERVED		22.01.16		NA
	CKD.	M.ASIM			22.01.16		
APPD.	K.C.PANDA			22.01.16			
DEPT. EME		SCALE N.T.S	WEIGHT(K.G.) 25.46	REF.TO ASSY.DRG. 01350131206	ITEM NO. 6	NO.OF ITEM NA	
CODE 425							
TITLE: I-BEAM OUT BOARD STIFFENER				DRAWING NO. 4-135-01-34070		REV. 00	

THE INFORMATION ON THIS DOCUMENT IS THE PROPERTY OF BHARAT HEAVY ELECTRICALS LIMITED. IT MUST NOT BE USED DIRECTLY OR INDIRECTLY IN ANY WAY DETRIMENTAL TO THE INTEREST OF THE COMPANY.

REV.	DATE	ALTERED	REV.	DATE	ALTERED	REV.	DATE	ALTERED
		CHECKED			CHECKED			CHECKED
		APPROVED			APPROVED			APPROVED

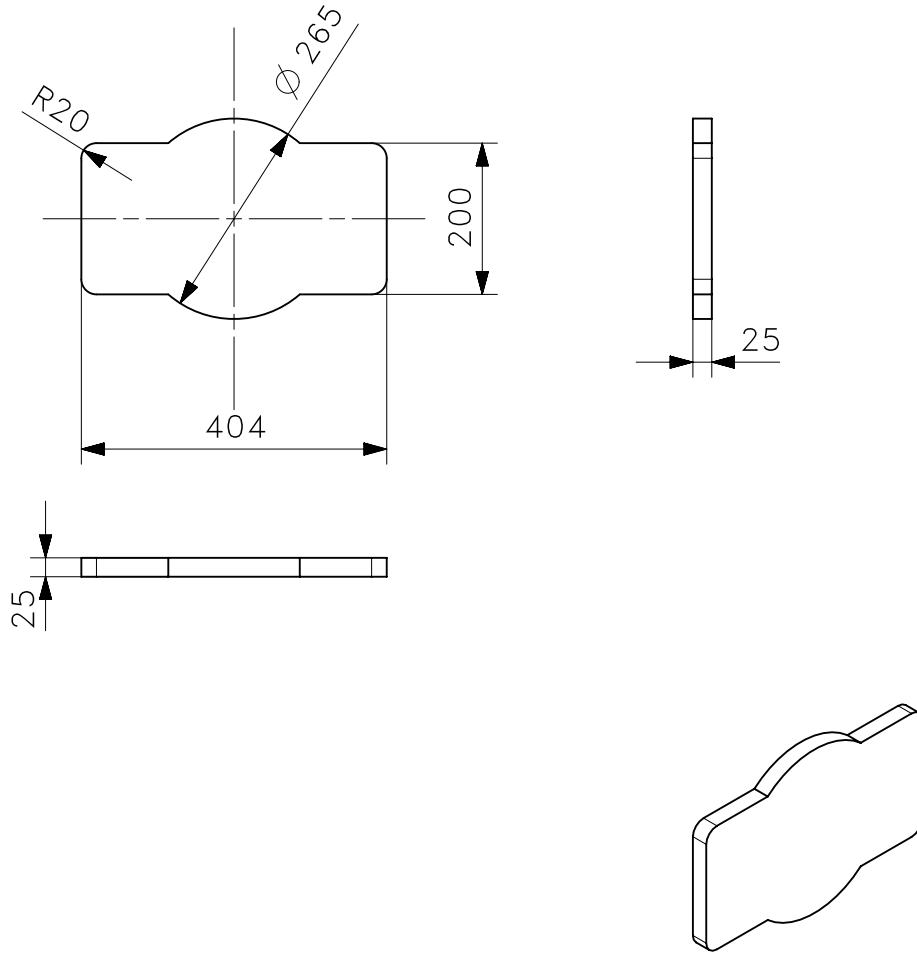

DESCRIPTION & DRG.NO.	VAR NO.	PL: 25	AA1011819155	17.50	
			AA10119	4	
		RAW MATERIAL SIZE OR CASTING DRG.NO. OR FORGING DRG.NO.	MATL. CODE	NET.WT.	GROSS WT
			MATL. SPECN.	QTY.	

TYPE OF PRODUCT OR NAME OF CUSTOMER/PROJECT: TARI 930-30P

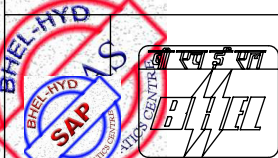

BHARAT HEAVY ELECTRICALS LTD. HYDERABAD

	NAME	SIGN	DATE	NO.OF VAR.
DRN.	A.PRAMODH	ASSIGNED	14.01.16	
CKD.	M.ASIM		14.01.16	NA
APPD.	K.C.PANDA		14.01.16	

REF. TO HY023026 UNSPECIFIED TOLERANCE

DEPT. EME		SCALE NTS	WEIGHT(K.G.) 17.50	REF.TO ASSY.DRG. 31350133828	ITEM NO. 2	NO.OF ITEM NA
CODE 425						
TITLE TRUNION FRONT PLATE				DRAWING NO. 4-135-01-34071	REV. 00	

THE INFORMATION ON THIS DOCUMENT IS THE PROPERTY OF BHARAT HEAVY ELECTRICALS LIMITED. IT MUST NOT BE USED DIRECTLY OR INDIRECTLY IN ANY WAY DETRIMENTAL TO THE INTEREST OF THE COMPANY.

REV.	DATE	ALTERED	REV.	DATE	ALTERED	REV.	DATE	ALTERED
		CHECKED			CHECKED			CHECKED
		APPROVED			APPROVED			APPROVED

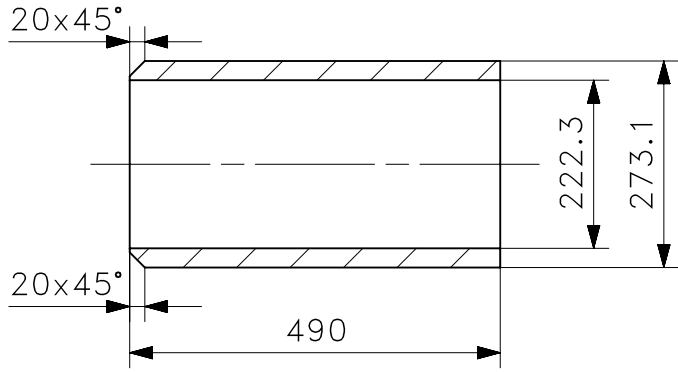
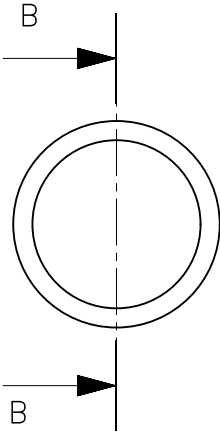

SECTION B-B

6.3 ✓

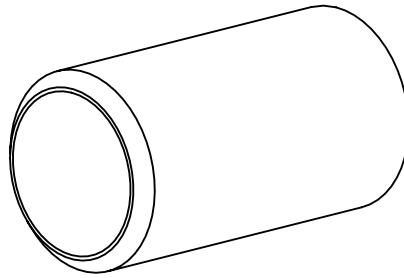

DESCRIPTION & DRG.NO.	VAR NO.	PIPE: 273x25.4	AA1049355806	112.50	
			AA10455	4	
		RAW MATERIAL SIZE OR CASTING DRG.NO. OR FORGING DRG.NO.	MATL. CODE	NET.WT.	GROSS WT
			MATL. SPECN.	QTY.	

TYPE OF PRODUCT OR NAME OF CUSTOMER/PROJECT

TARI 930-30P

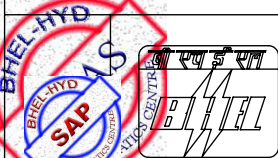

BHARAT HEAVY ELECTRICALS LTD.
HYDERABAD

	NAME	SIGN	DATE	NO.OF VAR.
DRN.	A.PRAMODH		14.01.16	
CKD.	M.ASIM		14.01.16	NA
APPD.	K.C.PANDA		14.01.16	NA

REF. TO HY023026 UNSPECIFIED TOLERANCE

DEPT. EME		SCALE N.T.S	WEIGHT(K.G.) 112.50	REF.TO ASSY.DRG. 31350133828	ITEM NO. 1	NO.OF ITEM NA
CODE 425						

TITLE	DRAWING NO.	REV.
TRUNION SLEEVE MACHINING	41350134072	00

THE INFORMATION ON THIS DOCUMENT IS THE PROPERTY OF BHARAT HEAVY ELECTRICALS LIMITED. IT MUST NOT BE USED DIRECTLY OR INDIRECTLY IN ANY WAY DETRIMENTAL TO THE INTEREST OF THE COMPANY.

REV.	DATE	ALTERED	A.PRAMODH	REV.	DATE	ALTERED	REV.	DATE	ALTERED
01	25.05.16	CHECKED	M.ASIM			CHECKED			CHECKED
		APPROVED	K.C.PANDA			APPROVED			APPROVED

DRAWING RE-DRAWN.

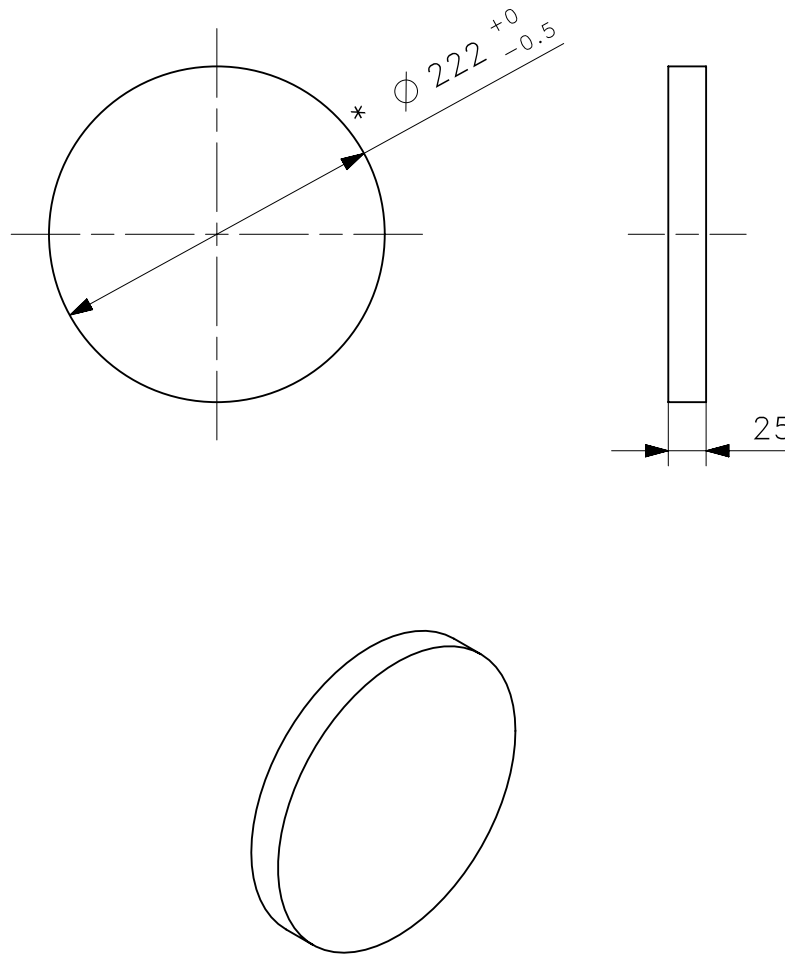

*ADAPT DURING ASSY.

DESCRIPTION & DRG.NO.	VAR NO.	PL: 25	AA1011819155	7.6	
			AA10119	4	
		RAW MATERIAL SIZE OR CASTING DRG.NO. OR FORGING DRG.NO.	MATL. CODE	NET.WT.	GROSS WT
			MATL. SPECN.	QTY.	

TYPE OF PRODUCT OR NAME OF CUSTOMER/PROJECT: TARI 860-21P

	BHARAT HEAVY ELECTRICALS LTD. HYDERABAD		NAME	SIGN	DATE	NO.OF VAR.
	DRN.	K.B.E	RESERVED	22.01.15	NO	
	CKD.	G.C.S.REDDY		22.01.15	NA	
APPD.	U.SRIDHAR	22.01.15		NA		
DEPT. EME		SCALE NTS	WEIGHT(K.G.) 7.6	REF.TO ASSY.DRG. 31350133864	ITEM NO. 4	NO.OF ITEM NA
CODE 425						
TITLE TRUNION MID STIFFENER				DRAWING NO. 4-135-01-34073	REV. 01	

THE INFORMATION ON THIS DOCUMENT IS THE PROPERTY OF BHARAT HEAVY ELECTRICALS LIMITED. IT MUST NOT BE USED DIRECTLY OR INDIRECTLY IN ANY WAY DETRIMENTAL TO THE INTEREST OF THE COMPANY.

25 ✓

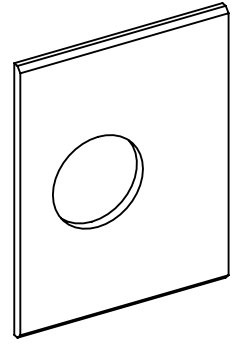
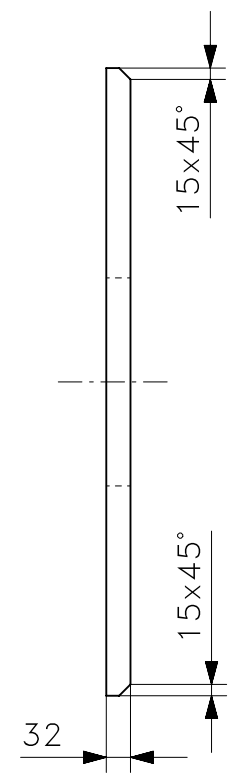
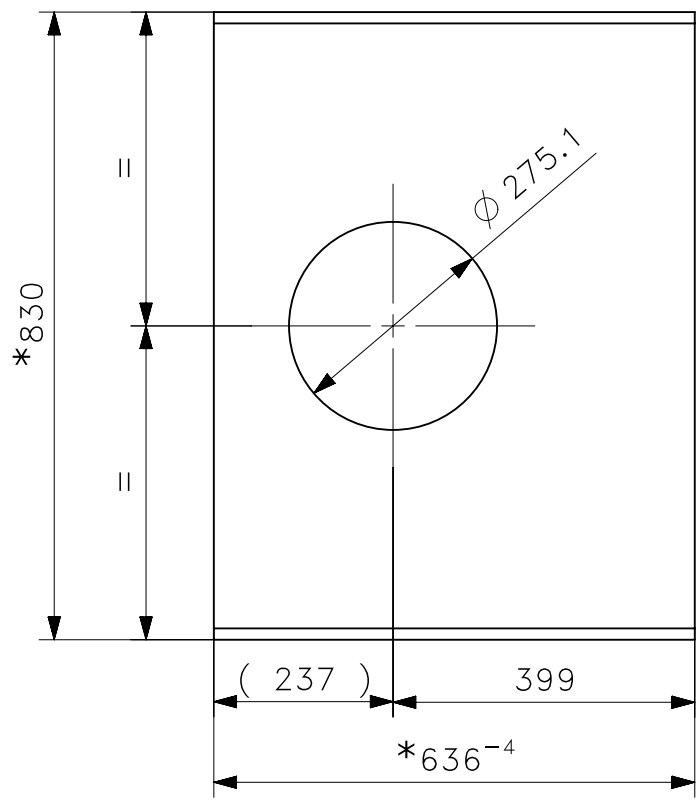

*ADAPT DURING ASSEMBLY

DESCRIPTION & DRG.NO.	VAR NO.	PL: 32	AA1011819171	114.50	
			AA10119	4	
		RAW MATERIAL SIZE OR CASTING DRG.NO. OR FORGING DRG.NO.	MATL. CODE	NET.WT.	GROSS WT
			MATL. SPECN.	QTY.	

TYPE OF PRODUCT OR NAME OF CUSTOMER/PROJECT: TARI 930-30P

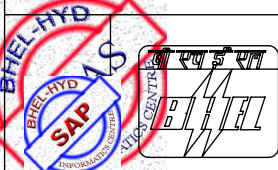

BHARAT HEAVY ELECTRICALS LTD.
HYDERABAD

	NAME	SIGN	DATE	NO.OF VAR.
DRN.	A. PRAMODH		14.01.16	
CKD.	M. ASIM		14.01.16	
APPD.	K. C. PANDA		14.01.16	NA

REF. TO HY023026 UNSPECIFIED TOLERANCE

DEPT. EME		SCALE N.T.S	WEIGHT(K.G.) 114.50	REF.TO ASSY.DRG. 01350131207	ITEM NO. 4	NO.OF ITEM NA
CODE 425						

TITLE	DRAWING NO.	REV.
LIFTING LUG BACK SUPPORT PLATE	4-135-01-34074	00

THE INFORMATION ON THIS DOCUMENT IS THE PROPERTY OF BHARAT HEAVY ELECTRICALS LIMITED. IT MUST NOT BE USED DIRECTLY OR INDIRECTLY IN ANY WAY DETRIMENTAL TO THE INTEREST OF THE COMPANY.

25 ✓

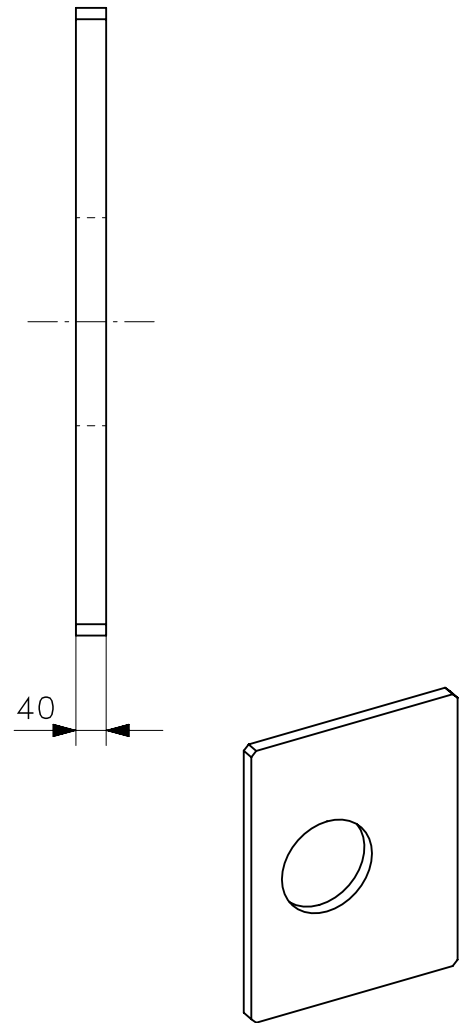
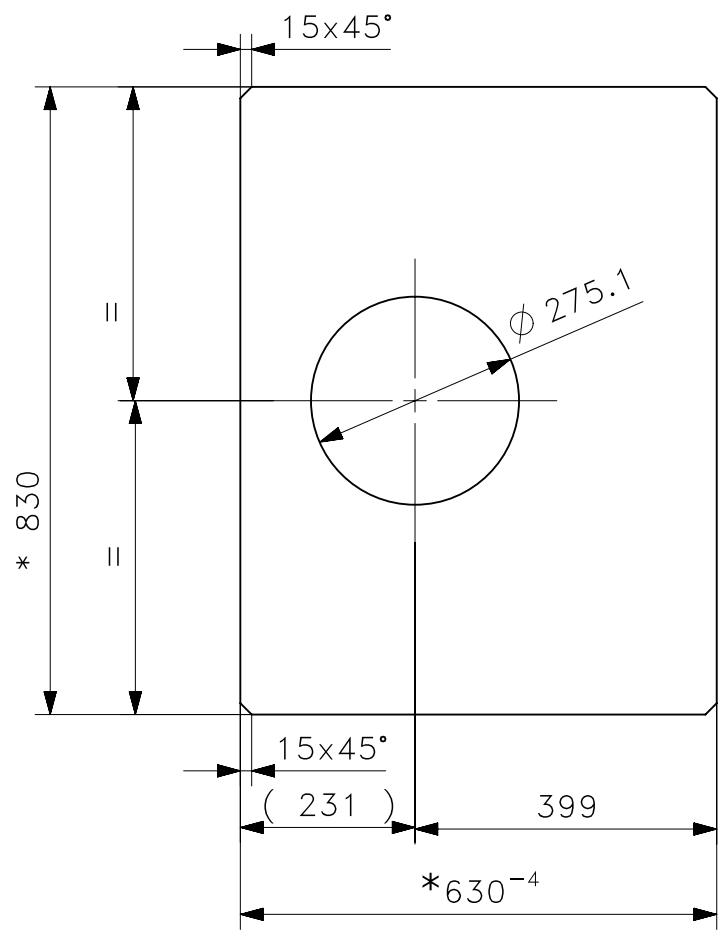

*ADAPT DURING ASSEMBLY

		PL: 40	AA1011819198	142.30	
			AA10119	4	
DESCRIPTION & DRG.NO.	VAR NO.	RAW MATERIAL SIZE OR CASTING DRG.NO. OR FORGING DRG.NO.	MATL. CODE	NET.WT.	GROSS WT
			MATL. SPECN.	QTY.	

TYPE OF PRODUCT OR NAME OF CUSTOMER/PROJECT: TARI 930-30P

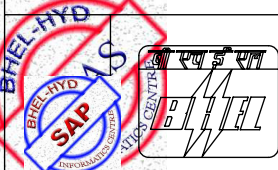

BHARAT HEAVY ELECTRICALS LTD. HYDERABAD

	NAME	SIGN	DATE	NO.OF VAR.
DRN.	A. PRAMODH		14.01.16	NA
CKD.	M. ASIM		14.01.16	
APPD.	K.C.PANDA		14.01.16	

DEPT. EME		SCALE N.T.S	WEIGHT(K.G.) 142.30	REF.TO ASSY.DRG. 01350131207	ITEM NO. 5	NO.OF ITEM NA
CODE 425						
TITLE: LIFTING LUG FRONT SUPPORT PLATE				DRAWING NO. 4-135-01-34075		REV. 00

THE INFORMATION ON THIS DOCUMENT IS THE PROPERTY OF BHARAT HEAVY ELECTRICALS LIMITED. IT MUST NOT BE USED DIRECTLY OR INDIRECTLY IN ANY WAY DETRIMENTAL TO THE INTEREST OF THE COMPANY.

REV.	DATE	ALTERED	REV.	DATE	ALTERED	REV.	DATE	ALTERED
		CHECKED			CHECKED			CHECKED
		APPROVED			APPROVED			APPROVED

25 ✓

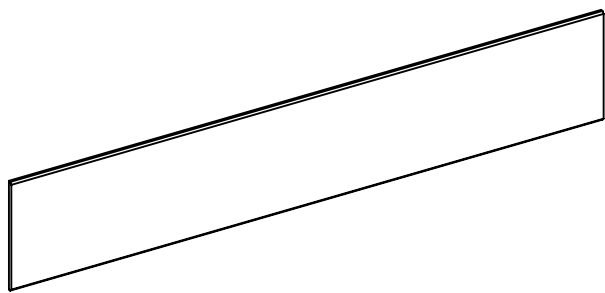
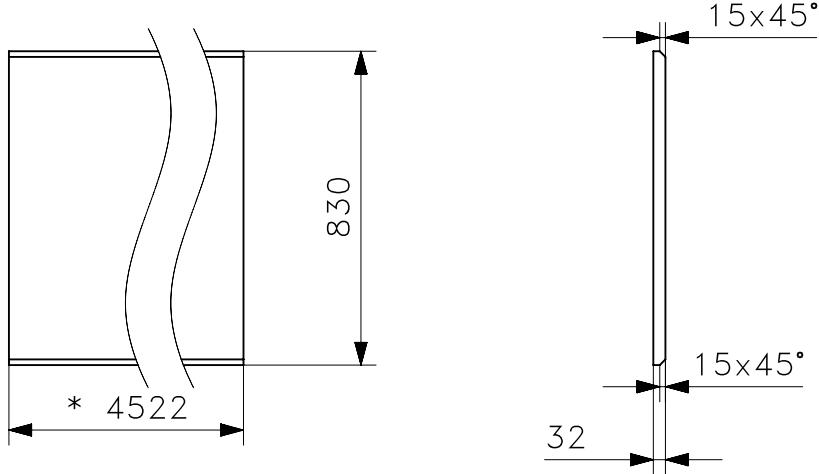

*ADAPT DURING ASSY.

DESCRIPTION & DRG.NO.	VAR NO.	PL: 25	AA1011819171	736.58	
		RAW MATERIAL SIZE OR CASTING DRG.NO. OR FORGING DRG.NO.	AA10119	2	
			MATL. CODE	NET.WT.	GROSS WT
			MATL. SPECN.	QTY.	

TYPE OF PRODUCT OR NAME OF CUSTOMER/PROJECT: TARI 930-30P

	BHARAT HEAVY ELECTRICALS LTD. HYDERABAD		NAME	SIGN	DATE	NO.OF VAR.	
	DEPT. EME		DRN. A.PRAMODH		14.01.16		NA
	CODE 425		CKD. M.ASIM		14.01.16		
TITLE	APPD. K.C.PANDA		14.01.16				
DEPT. EME	SCALE N.T.S	WEIGHT(K.G.) 736.58	REF.TO ASSY.DRG. 01350131207	ITEM NO. 2	NO.OF ITEM NA		
LONGITUDINAL STIFFENER			DRAWING NO. 4-135-01-34076	REV. 00			

THE INFORMATION ON THIS DOCUMENT IS THE PROPERTY OF BHARAT HEAVY ELECTRICALS LIMITED. IT MUST NOT BE USED DIRECTLY OR INDIRECTLY IN ANY WAY DETRIMENTAL TO THE INTEREST OF THE COMPANY.

25 ✓

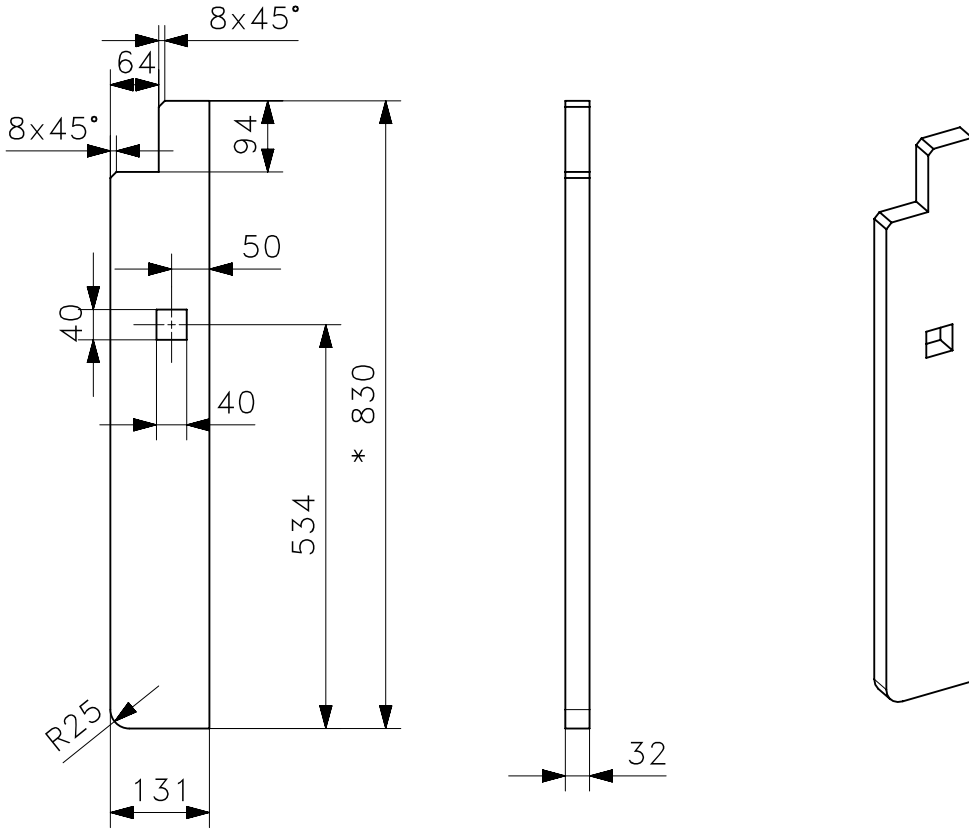

*ADAPT DURING ASSEMBLY.

DESCRIPTION & DRG.NO.	VAR NO.	PL: 32	AA1011819171	24.83	
			AA10119	12	
		RAW MATERIAL SIZE OR CASTING DRG.NO. OR FORGING DRG.NO.	MATL. CODE	NET.WT.	GROSS WT
			MATL. SPECN.	QTY.	

TYPE OF PRODUCT OR NAME OF CUSTOMER/PROJECT: TARI-930-30P

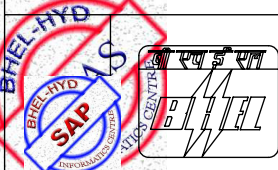

BHARAT HEAVY ELECTRICALS LTD. HYDERABAD

	NAME	SIGN	DATE	NO.OF VAR.
DRN.	A.PRAMODH	ASIM	22.01.16	
CKD.	M.ASIM		22.01.16	NA
APPD.	K.C.PANDA		22.01.16	

REF. TO HY023026 UNSPECIFIED TOLERANCES

DEPT. EME		SCALE N.T.S	WEIGHT(K.G.) 24.83	REF.TO ASSY.DRG. 01350131206	ITEM NO. 8	NO.OF ITEM NA
CODE 425						

TITLE I-BEAM OUT BOARD STIFFENER WITH HOLE	DRAWING NO. 4-135-01-34077	REV. 00
--	----------------------------	---------

THE INFORMATION ON THIS DOCUMENT IS THE PROPERTY OF BHARAT HEAVY ELECTRICALS LIMITED. IT MUST NOT BE USED DIRECTLY OR INDIRECTLY IN ANY WAY DETRIMENTAL TO THE INTEREST OF THE COMPANY.

25 ✓

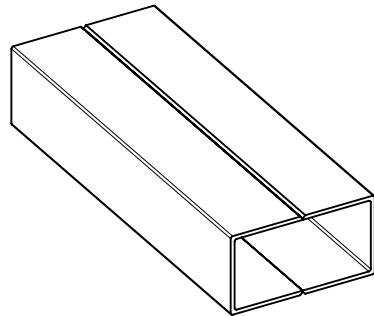
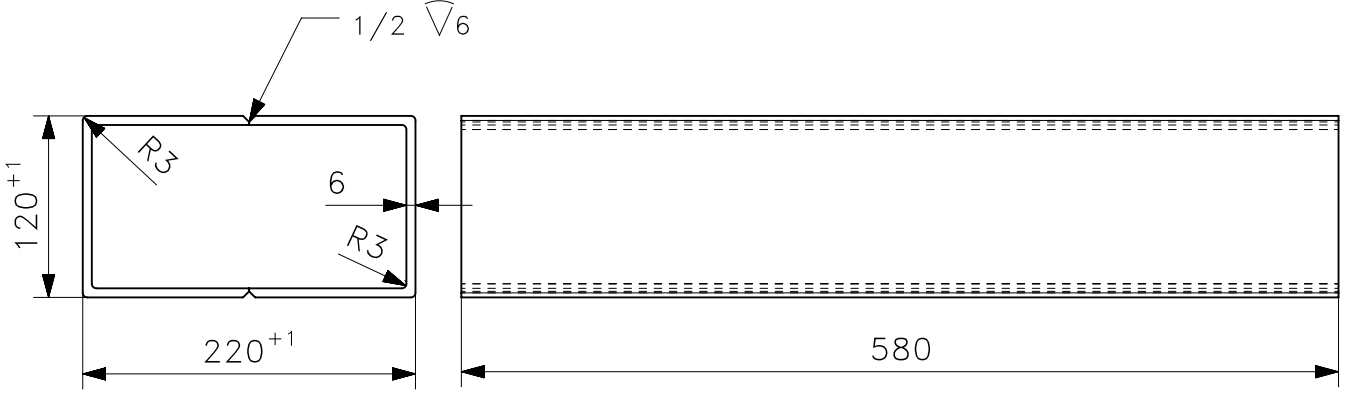

COMPUTER NO.	REF. DRG. NO.	DESCRIPTION & DRG.NO.	VAR NO.	PL: 6	AA1011808030	13.20	
					AA10108	2	
INVENTORY NO.	SIGN. & DATE	TYPE OF PRODUCT OR NAME OF CUSTOMER/PROJECT		TARI 930-30P			
		UNSPECIFIED TOLERANCE		MATERIAL SIZE OR CASTING DRG.NO. OR FORGING DRG.NO.		MATL. SPECN.	NET.WT.

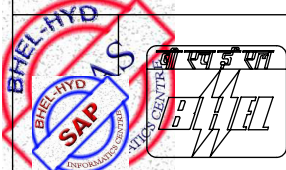

BHARAT HEAVY ELECTRICALS LTD.
HYDERABAD

	NAME	SIGN	DATE	NO.OF VAR.
DRN.	A.PRAMODH	ASIM ASIM	14.01.16	
CKD.	M.ASIM		14.01.16	NA
APPD.	K.C.PANDA		14.01.16	

DEPT. EME		SCALE N.T.S	WEIGHT(K.G.) 13.20	REF.TO ASSY.DRG. 01350131206	ITEM NO. 37	NO.OF ITEM NA
CODE 425						

TITLE	DRAWING NO.	REV.
MAIN CABLE DUCT	4-135-01-34078	00

THE INFORMATION ON THIS DOCUMENT IS THE PROPERTY OF BHARAT HEAVY ELECTRICALS LIMITED. IT MUST NOT BE USED DIRECTLY OR INDIRECTLY IN ANY WAY DETRIMENTAL TO THE INTEREST OF THE COMPANY.

25/

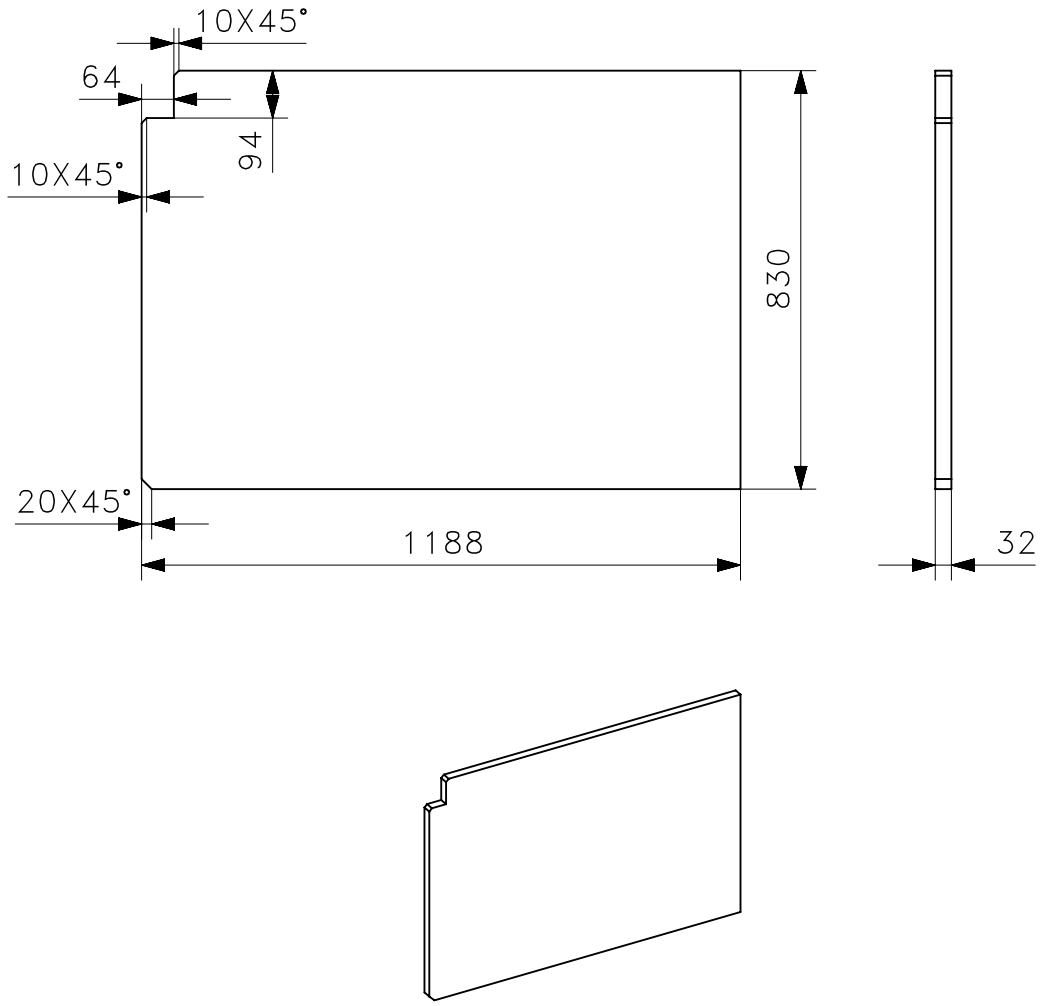

INVENTORY NO. SIGN. & DATE (REF. DRG. NO. COMPUTER NO.)

		PL: 32	AA1011819171	245.50	
			AA10119	3	
DESCRIPTION & DRG.NO.	VAR NO.	RAW MATERIAL SIZE OR CASTING DRG.NO. OR FORGING DRG.NO.	MATL. CODE	NET.WT.	GROSS WT
			MATL. SPECN.	QTY.	

TYPE OF PRODUCT OR NAME OF CUSTOMER/PROJECT: TARI-930-30P

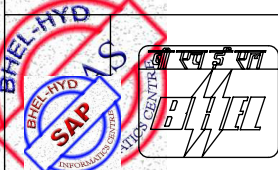

BHARAT HEAVY ELECTRICALS LTD. HYDERABAD

	NAME	SIGN	DATE	NO.OF VAR.
DRN.	A.PRAMODH	RESERVED	22.01.16	
CKD.	M.ASIM		22.01.16	NA
APPD.	K.C.PANDA		22.01.16	

REF. TO HY023026 UNSPECIFIED TOLERANCE

DEPT. EME		SCALE N.T.S	WEIGHT(K.G.) 245.50	REF.TO ASSY.DRG. 01350131206	ITEM NO. 28	NO.OF ITEM NA
CODE 425						

TITLE: STIFFENER BELOW EXCITER	DRAWING NO. 41350134079	REV. 00
--------------------------------	-------------------------	---------

THE INFORMATION ON THIS DOCUMENT IS THE PROPERTY OF BHARAT HEAVY ELECTRICALS LIMITED. IT MUST NOT BE USED DIRECTLY OR INDIRECTLY IN ANY WAY DETRIMENTAL TO THE INTEREST OF THE COMPANY.

25 ✓

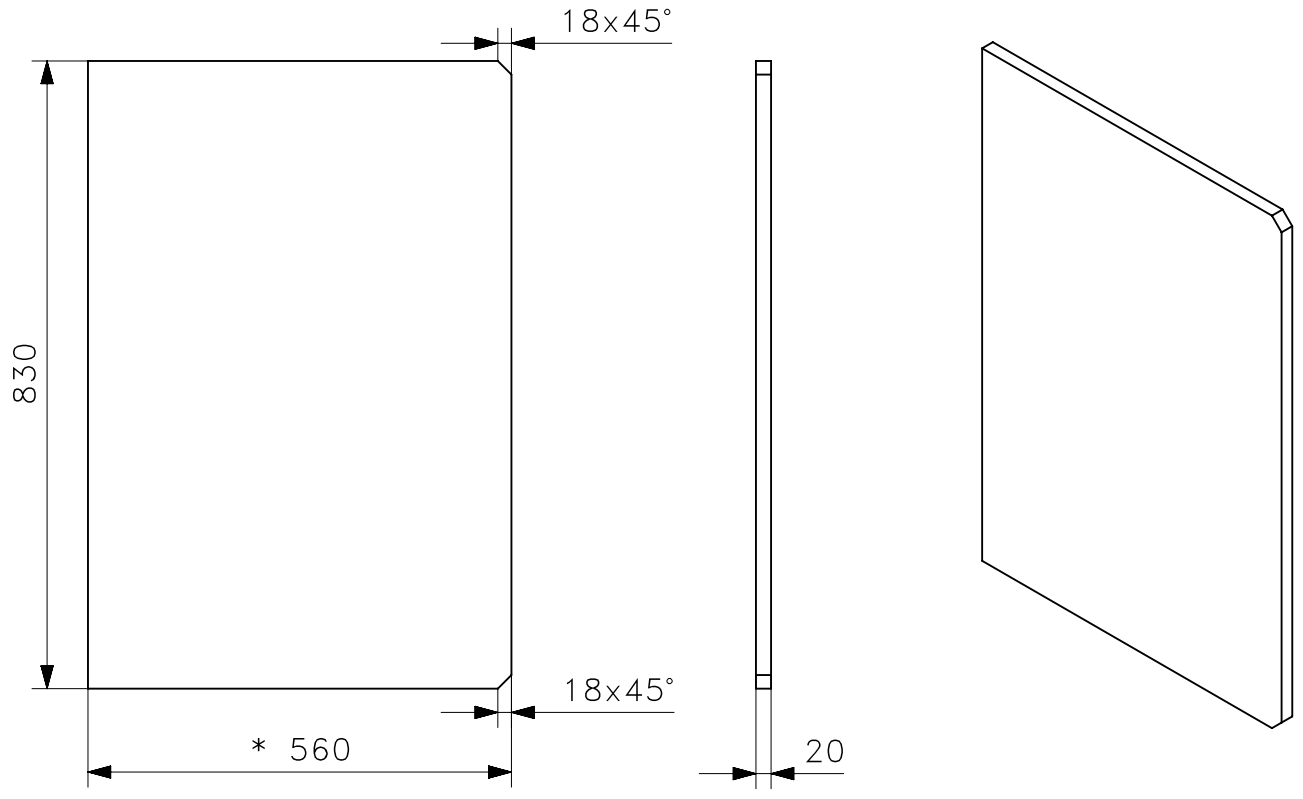

*ADAPT DURING ASSY.

DESCRIPTION & DRG.NO.	VAR NO.	PL: 20	AA1011819139	72.90	
			AA10119	10	
		RAW MATERIAL SIZE OR CASTING DRG.NO. OR FORGING DRG.NO.	MATL. CODE	NET.WT.	GROSS WT
			MATL. SPECN.	QTY.	

TYPE OF PRODUCT OR NAME OF CUSTOMER/PROJECT: TARI 930-30P

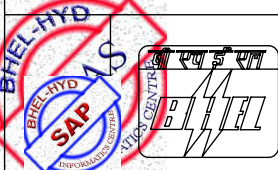

BHARAT HEAVY ELECTRICALS LTD. HYDERABAD

	NAME	SIGN	DATE	NO.OF VAR.
DRN.	A.PRAMODH	RESERVED	14.01.16	
CKD.	M.ASIM		14.01.16	NA
APPD.	K.C.PANDA		14.01.16	

REF. TO HY023026 UNSPECIFIED TOLERANCE

DEPT. EME		SCALE NTS	WEIGHT(K.G.) 72.90	REF.TO ASSY.DRG. 01350131206	ITEM NO. 27	NO.OF ITEM NA
CODE 425				DRAWING NO. 4-135-01-34080		REV. 00
TITLE SUPPORT PLATE BELOW BRG				DRW NO. 01	NO OF SET 01	

THE INFORMATION ON THIS DOCUMENT IS THE PROPERTY OF BHARAT HEAVY ELECTRICALS LIMITED. IT MUST NOT BE USED DIRECTLY OR INDIRECTLY IN ANY WAY DETRIMENTAL TO THE INTEREST OF THE COMPANY.

25
✓

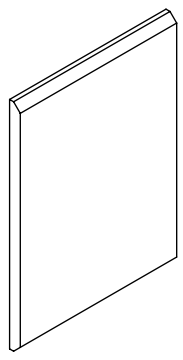
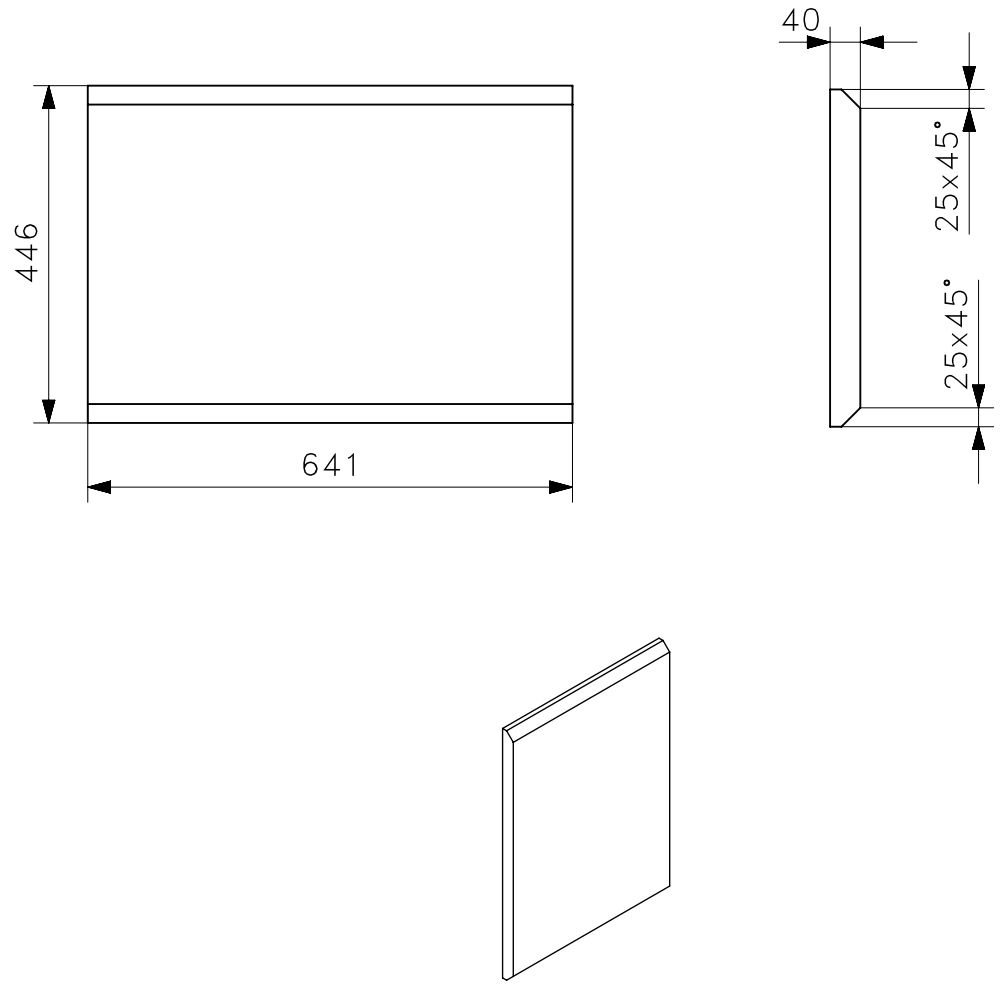

DESCRIPTION & DRG.NO.	VAR NO.	PL: 40	AA1011819198	87.50	
			AA10119	4	
		RAW MATERIAL SIZE OR CASTING DRG.NO. OR FORGING DRG.NO.	MATL. CODE	NET.WT.	GROSS WT
			MATL. SPECN.	QTY.	

TYPE OF PRODUCT OR NAME OF CUSTOMER/PROJECT: TARI-930-30P

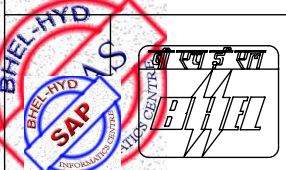

BHARAT HEAVY ELECTRICALS LTD.
HYDERABAD

	NAME	SIGN	DATE	NO.OF VAR.
DRN.	A.PRAMODH	RESERVED	22.01.16	
CKD.	M.ASIM		22.01.16	NA
APPD.	K.C.PANDA		22.01.16	

DEPT. EME		SCALE NTS	WEIGHT(K.G.) 87.50	REF.TO ASSY.DRG. 01350131206	ITEM NO. 38	NO.OF ITEM NA
CODE 425						

TITLE TS & ES TOP MOUNTING PLATE	DRAWING NO. 41350134082	REV. 00
-------------------------------------	----------------------------	------------

THE INFORMATION ON THIS DOCUMENT IS THE PROPERTY OF BHARAT HEAVY ELECTRICALS LIMITED. IT MUST NOT BE USED DIRECTLY OR INDIRECTLY IN ANY WAY DETRIMENTAL TO THE INTEREST OF THE COMPANY.

25 ✓

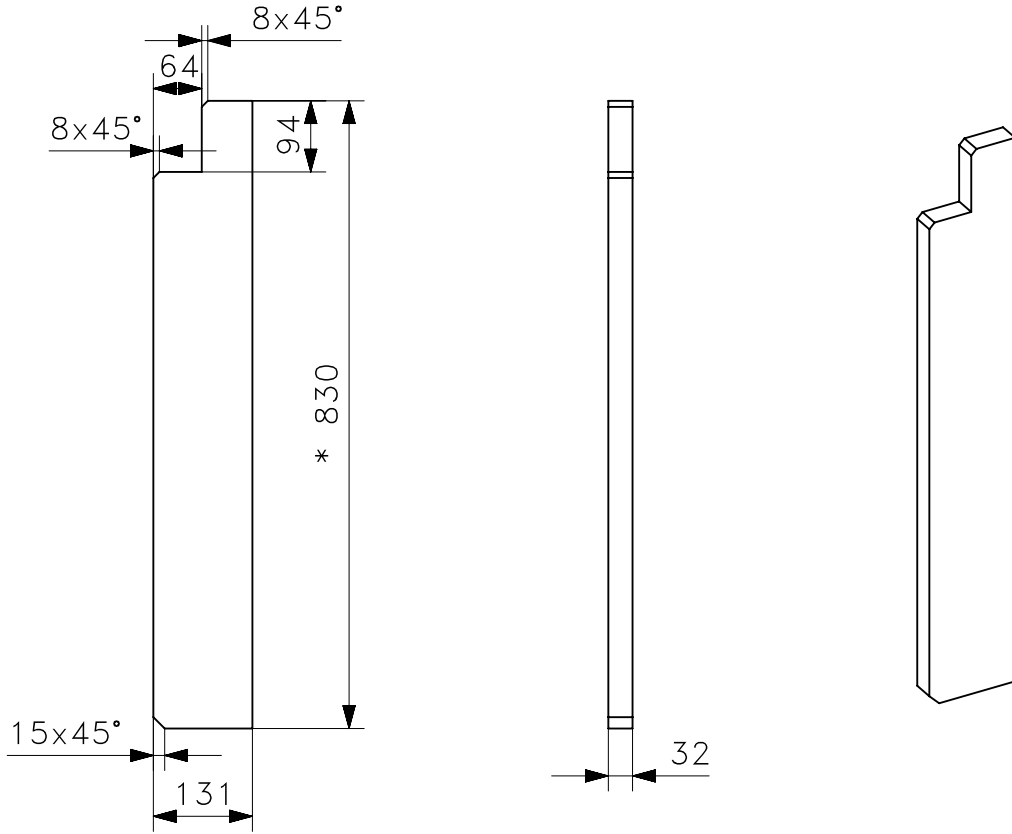

*ADAPT DURING ASSEMBLY.

DESCRIPTION & DRG.NO.	VAR NO.	RAW MATERIAL SIZE OR CASTING DRG.NO. OR FORGING DRG.NO.	AA1011819171	25.46	
			AA10119	10	
		PL: 32			
			MATL. CODE	NET.WT.	GROSS WT
			MATL. SPECN.	QTY.	

TYPE OF PRODUCT OR NAME OF CUSTOMER/PROJECT: TARI-930-30P

BHARAT HEAVY ELECTRICALS LTD. HYDERABAD

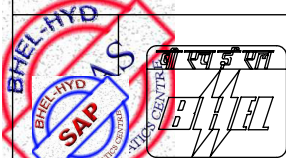

	NAME	SIGN	DATE	NO.OF VAR.
DRN.	A.PRAMODH		22.01.16	
CKD.	M.ASIM		22.01.16	
APPD.	K.C.PANDA		22.01.16	NA

DEPT. EME		SCALE N.T.S	WEIGHT(K.G.) 25.46	REF.TO ASSY.DRG. 01350131206	ITEM NO. 30	NO.OF ITEM NA
CODE 425						

TITLE INBOARD STIFFENER BELOW BRG	DRAWING NO. 4-135-01-34083	REV. 00
-----------------------------------	----------------------------	---------

THE INFORMATION ON THIS DOCUMENT IS THE PROPERTY OF BHARAT HEAVY ELECTRICALS LIMITED. IT MUST NOT BE USED DIRECTLY OR INDIRECTLY IN ANY WAY DETRIMENTAL TO THE INTEREST OF THE COMPANY.

REV.	DATE	ALTERED	REV.	DATE	ALTERED	REV.	DATE	ALTERED
		CHECKED			CHECKED			CHECKED
		APPROVED			APPROVED			APPROVED

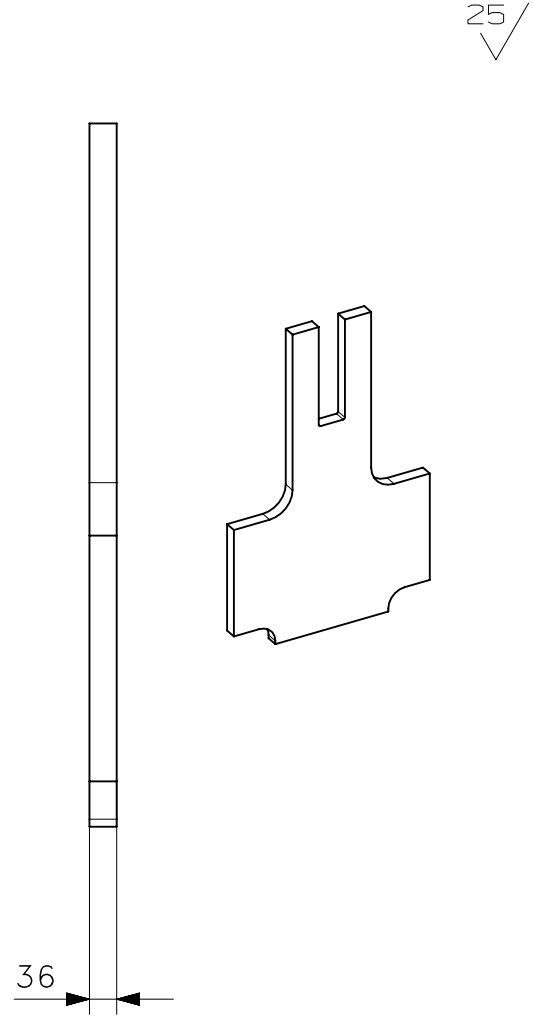
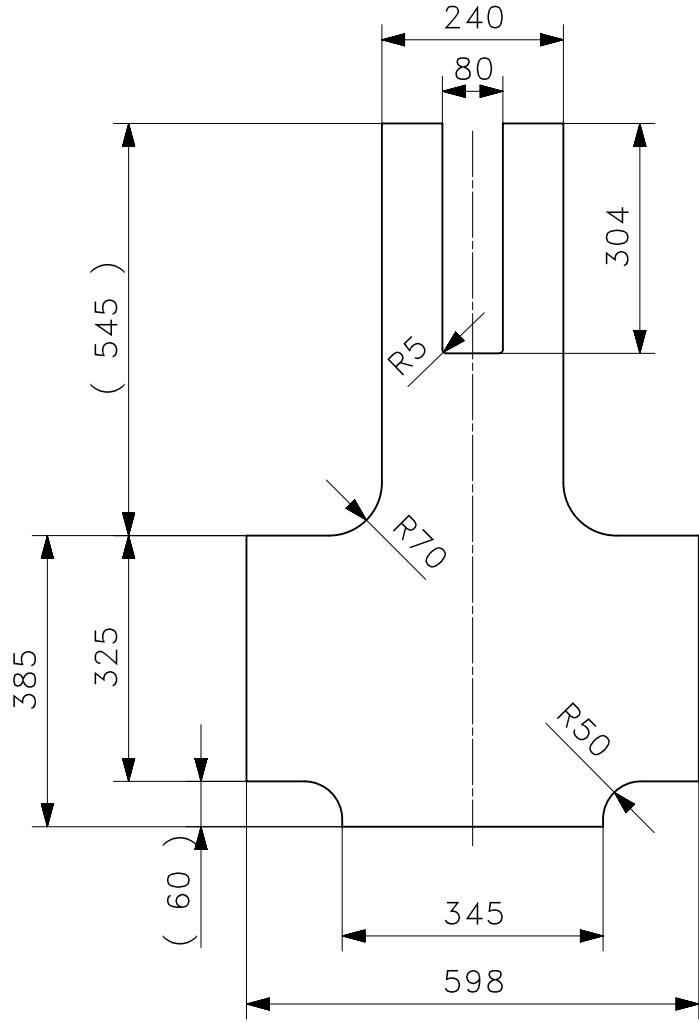

25/

DESCRIPTION & DRG.NO.	VAR NO.	PL: 36	AA1011819180	159.50	
			AA10119	2	
		RAW MATERIAL SIZE OR CASTING DRG.NO. OR FORGING DRG.NO.	MATL. CODE	NET.WT.	GROSS WT
			MATL. SPECN.	QTY.	

TYPE OF PRODUCT OR NAME OF CUSTOMER/PROJECT

TARI-930-30P



BHARAT HEAVY ELECTRICALS LTD. HYDERABAD

	NAME	SIGN	DATE	NO.OF VAR.
DRN.	A.PRAMODH	RESERVED	22.01.16	
CKD.	M.ASIM		22.01.16	NA
APPD.	K.C.PANDA		22.01.16	

DEPT. EME		SCALE N.T.S	WEIGHT(K.G.) 159.50	REF.TO ASSY.DRG. 01350131205	ITEM NO. 2	NO.OF ITEM NA
CODE 425						
TITLE CROSS PIECE CENTER				DRAWING NO. 4-135-01-34084		REV. 00

THE INFORMATION ON THIS DOCUMENT IS THE PROPERTY OF BHARAT HEAVY ELECTRICALS LIMITED. IT MUST NOT BE USED DIRECTLY OR INDIRECTLY IN ANY WAY DETRIMENTAL TO THE INTEREST OF THE COMPANY.

REV.	DATE	ALTERED	REV.	DATE	ALTERED	REV.	DATE	ALTERED
		CHECKED			CHECKED			CHECKED
		APPROVED			APPROVED			APPROVED

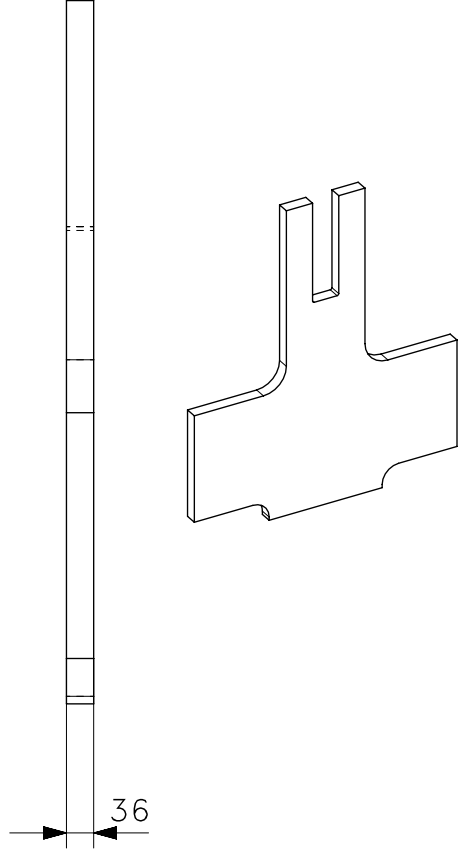
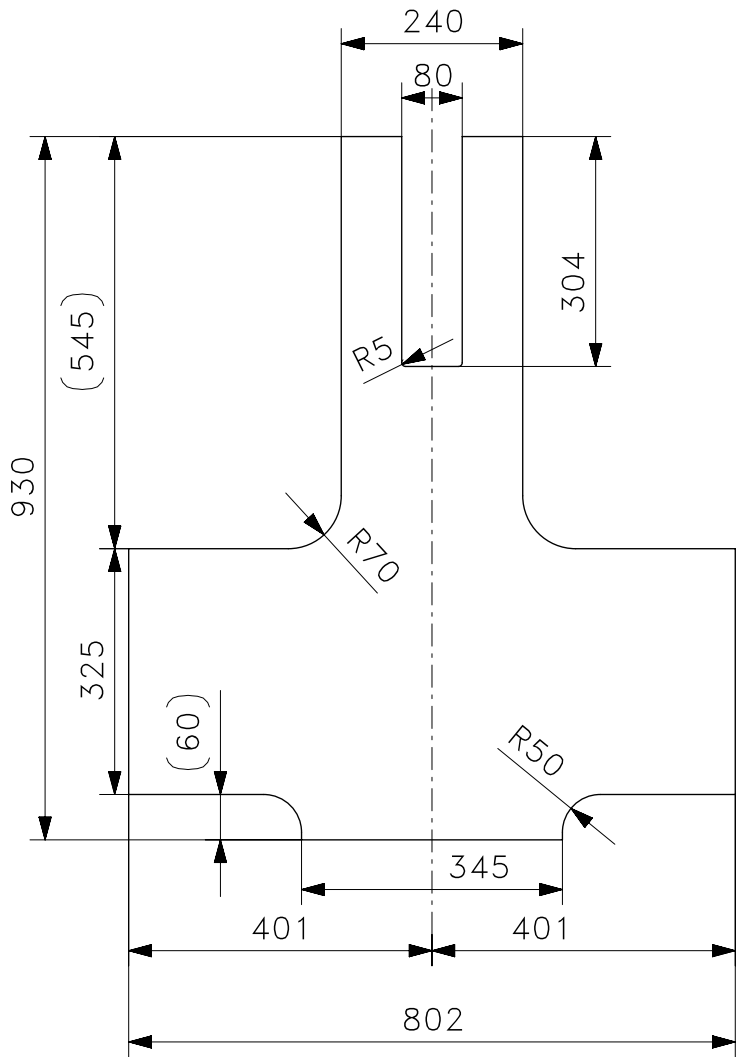

25/

DESCRIPTION & DRG.NO.	VAR NO.	PL: 36	AA1011819180	110.75	
		RAW MATERIAL SIZE OR CASTING DRG.NO. OR FORGING DRG.NO.	AA10119	4	
			MATL. CODE	NET.WT.	GROSS WT
			MATL. SPECN.	QTY.	

TYPE OF PRODUCT OR NAME OF CUSTOMER/PROJECT

TARI-930-30P

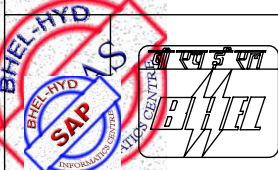

BHARAT HEAVY ELECTRICALS LTD. HYDERABAD

	NAME	SIGN	DATE	NO.OF VAR.
DRN.	A . PRAMODH		22.01.16	
CKD.	M. ASIM		22.01.16	
APPD.	K . C . PANDA		22.01.16	NA

DEPT. EME		SCALE N.T.S	WEIGHT(K.G.) 110.75	REF.TO ASSY.DRG. 01350131205	ITEM NO. 3	NO.OF ITEM NA
CODE 425						
TITLE CROSS PIECE END				DRAWING NO. 41350134085		REV. 00

THE INFORMATION ON THIS DOCUMENT IS THE PROPERTY OF BHARAT HEAVY ELECTRICALS LIMITED. IT MUST NOT BE USED DIRECTLY OR INDIRECTLY IN ANY WAY DETRIMENTAL TO THE INTEREST OF THE COMPANY.

25/

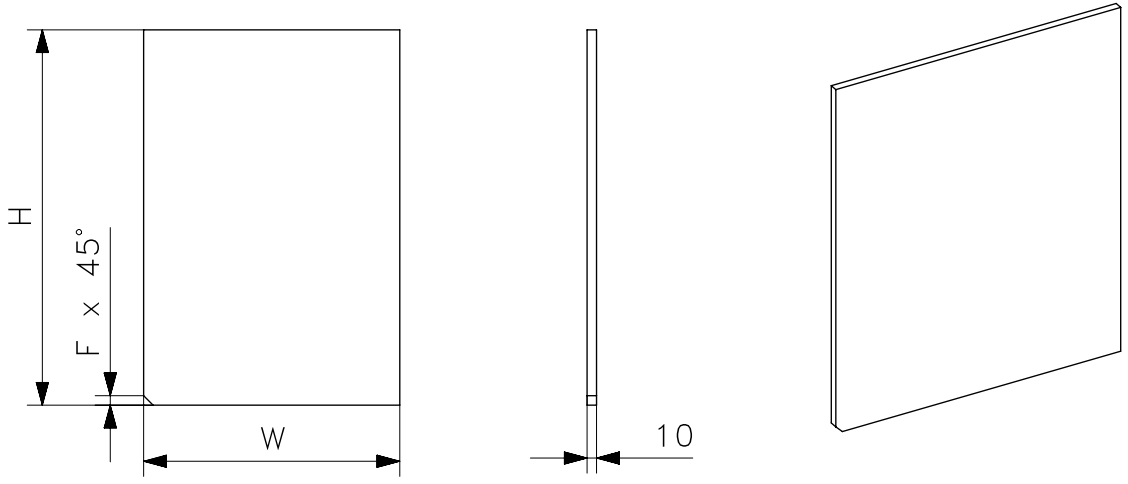

VAR NO	POS. NO.	W	H	F	Qty	Wt
01	12	271	641	12	2	13.6
02	13	271	397	-	1	8.43

NOTE:
ADAPT DIMENSIONS DURING ASSEMBLY

		PL: 10	AA1011819090	SEE TABLE
			AA10119	SEE TABLE
DESCRIPTION & DRG.NO.	VAR NO.	RAW MATERIAL SIZE OR CASTING DRG.NO. OR FORGING DRG.NO.	MATL. CODE	NET.WT. GROSS WT
			MATL. SPECN.	QTY.

TYPE OF PRODUCT OR NAME OF CUSTOMER/PROJECT: TARI-930-30P

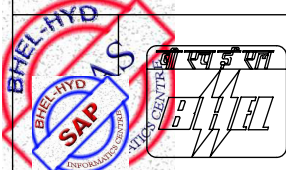

BHARAT HEAVY ELECTRICALS LTD.
HYDERABAD

	NAME	SIGN	DATE	NO.OF VAR.
DRN.	A. PRAMODH		22.01.16	
CKD.	M.ASIM		22.01.16	NA
APPD.	K.C.PANDA		22.01.16	

DEPT. EME		SCALE N.T.S	WEIGHT(K.G.) SEE TABLE	REF.TO ASSY.DRG. 01350131205	ITEM NO. 12,13	NO.OF ITEM NA
CODE 425						

TITLE	DRAWING NO.	REV.
EXCITER VENT BOT AND TOP VERTICAL PLT	4-135-01-34088	00

REF. TO HY023026 UNSPECIFIED TOLERANCE

Apr Fri 15 08:28 2016

THE INFORMATION ON THIS DOCUMENT IS THE PROPERTY OF BHARAT HEAVY ELECTRICALS LIMITED. IT MUST NOT BE USED DIRECTLY OR INDIRECTLY IN ANY WAY DETRIMENTAL TO THE INTEREST OF THE COMPANY.

REV.	DATE	ALTERED	REV.	DATE	ALTERED	REV.	DATE	ALTERED
		CHECKED			CHECKED			CHECKED
		APPROVED			APPROVED			APPROVED

25 ✓

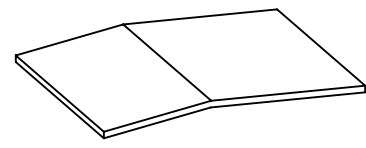
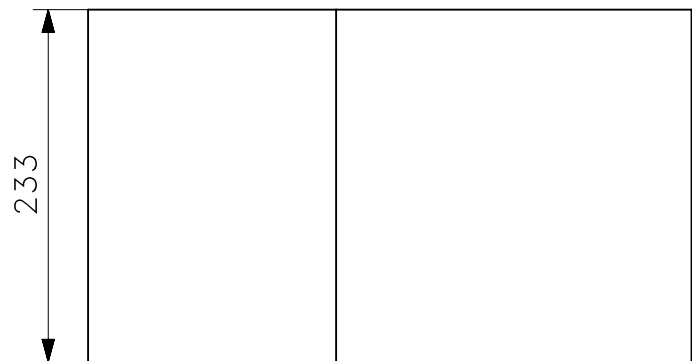
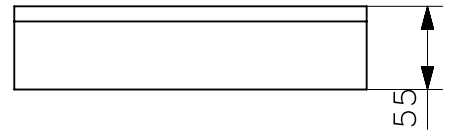
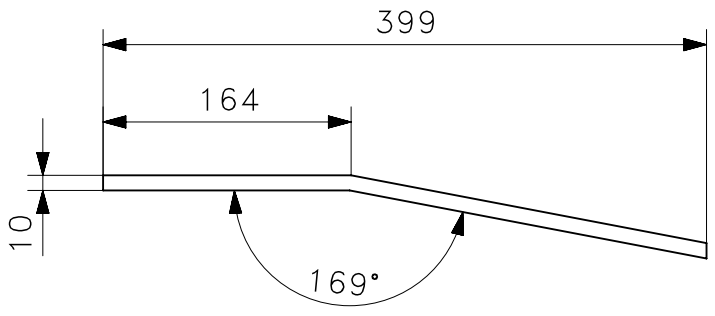

DEVELOPED LENGTH: 405 MM.

		PL: 10	AA1011819074	7.85	
			AA10119	2	
DESCRIPTION & DRG.NO.	VAR NO.	RAW MATERIAL SIZE OR CASTING DRG.NO. OR FORGING DRG.NO.	MATL. CODE	NET.WT.	GROSS WT
			MATL. SPECN.	QTY.	

TYPE OF PRODUCT OR NAME OF CUSTOMER/PROJECT: TARI 930-30P



BHARAT HEAVY ELECTRICALS LTD. HYDERABAD

	NAME	SIGN	DATE	
DRN.	A.PRAMODH	RESERVED	14.01.16	NO.OF VAR.
CKD.	M.ASIM		14.01.16	NA
APPD.	K.C.PANDA		14.01.16	

REF. TO HY023026 UNSPECIFIED TOLERANCE

DEPT. EME		SCALE N.T.S	WEIGHT(K.G.) 7.85	REF.TO ASSY.DRG. 01350131205	ITEM NO. 21	NO.OF ITEM NA
CODE 425						

TITLE	DRAWING NO.	REV.
LIFT LUG HRZ COVER ES	41350134089	00

THE INFORMATION ON THIS DOCUMENT IS THE PROPERTY OF BHARAT HEAVY ELECTRICALS LIMITED. IT MUST NOT BE USED DIRECTLY OR INDIRECTLY IN ANY WAY DETRIMENTAL TO THE INTEREST OF THE COMPANY.

25 ✓

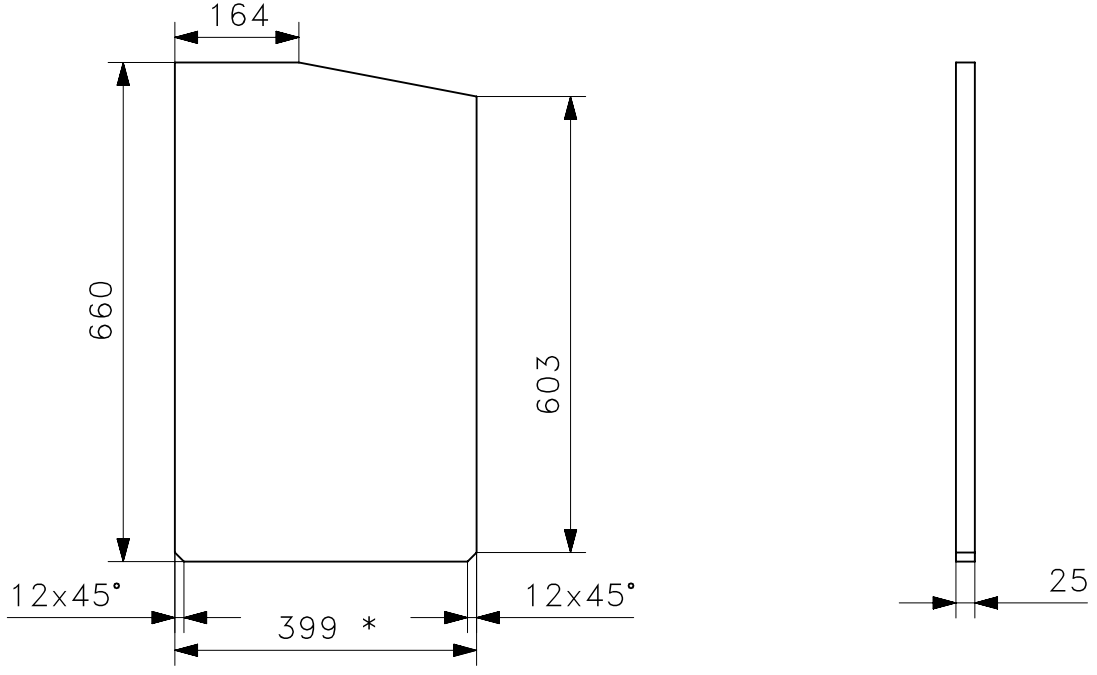

SCALE 1:10

*ADAPT DURING ASSEMBLY

		PL: 25	AA1011819155	51.95	
			AA10119	2	
DESCRIPTION & DRG.NO.	VAR NO.	RAW MATERIAL SIZE OR CASTING DRG.NO. OR FORGING DRG.NO.	MATL. CODE	NET.WT.	GROSS WT
			MATL. SPECN.	QTY.	

TYPE OF PRODUCT OR NAME OF CUSTOMER/PROJECT: TARI 930-30P

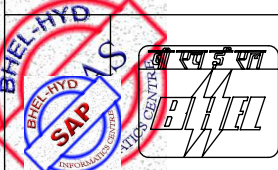

BHARAT HEAVY ELECTRICALS LTD.
HYDERABAD

	NAME	SIGN	DATE	NO.OF VAR.
DRN.	A.PRAMODH	ASIM	14.01.16	NA
CKD.	M.ASIM		14.01.16	
APPD.	K.C.PANDA		14.01.16	

DEPT. EME		SCALE N.T.S	WEIGHT(K.G.) 51.95	REF.TO ASSY.DRG. 01350131205	ITEM NO. 20	NO.OF ITEM NA
CODE 425						
TITLE: LIFT LUG VERTICAL COVER ES				DRAWING NO. 41350134091		REV. 00

THE INFORMATION ON THIS DOCUMENT IS THE PROPERTY OF BHARAT HEAVY ELECTRICALS LIMITED. IT MUST NOT BE USED DIRECTLY OR INDIRECTLY IN ANY WAY DETRIMENTAL TO THE INTEREST OF THE COMPANY.

REV.	DATE	ALTERED	REV.	DATE	ALTERED	REV.	DATE	ALTERED
		CHECKED			CHECKED			CHECKED
		APPROVED			APPROVED			APPROVED

--	--	--	--	--	--	--	--	--

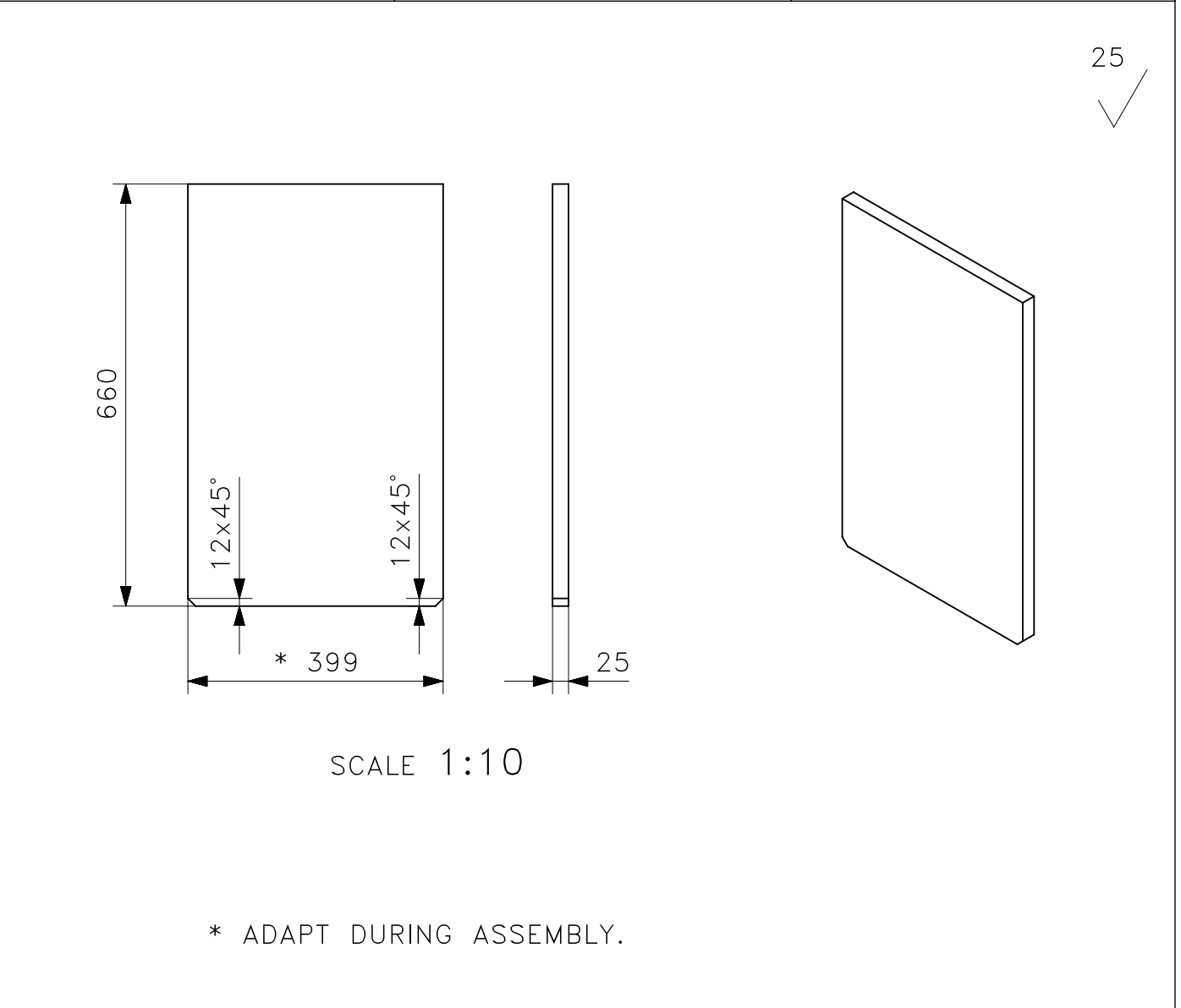

		PLATE: 25	AA1011819155	50.80	
			AA10119	2	
DESCRIPTION & DRG.NO.	VAR NO.	RAW MATERIAL SIZE OR CASTING DRG.NO. OR FORGING DRG.NO.	MATL. CODE	NET.WT.	GROSS WT
			MATL. SPECN.	QTY.	

TYPE OF PRODUCT OR NAME OF CUSTOMER/PROJECT: **TARI 930-30P**

	BHARAT HEAVY ELECTRICALS LTD. HYDERABAD		NAME	SIGN	DATE	NO.OF VAR. NA
	DRN.	A.PRAMODH	RESERVED		14.01.16	
	CKD.	M.ASIM			14.01.16	
APPD.	K.C.PANDA			14.01.16		
DEPT. EME		SCALE NTS	WEIGHT(K.G.) 50.80	REF.TO ASSY.DRG. 01350131205	ITEM NO. 18	NO.OF ITEM NA
CODE 425						
TITLE: LIFT LUG VERTICAL COVER TS				DRAWING NO. 41350134092		REV. 00

THE INFORMATION ON THIS DOCUMENT IS THE PROPERTY OF BHARAT HEAVY ELECTRICALS LIMITED. IT MUST NOT BE USED DIRECTLY OR INDIRECTLY IN ANY WAY DETRIMENTAL TO THE INTEREST OF THE COMPANY.

REV.	DATE	ALTERED	REV.	DATE	ALTERED	REV.	DATE	ALTERED
		CHECKED			CHECKED			CHECKED
		APPROVED			APPROVED			APPROVED

25/

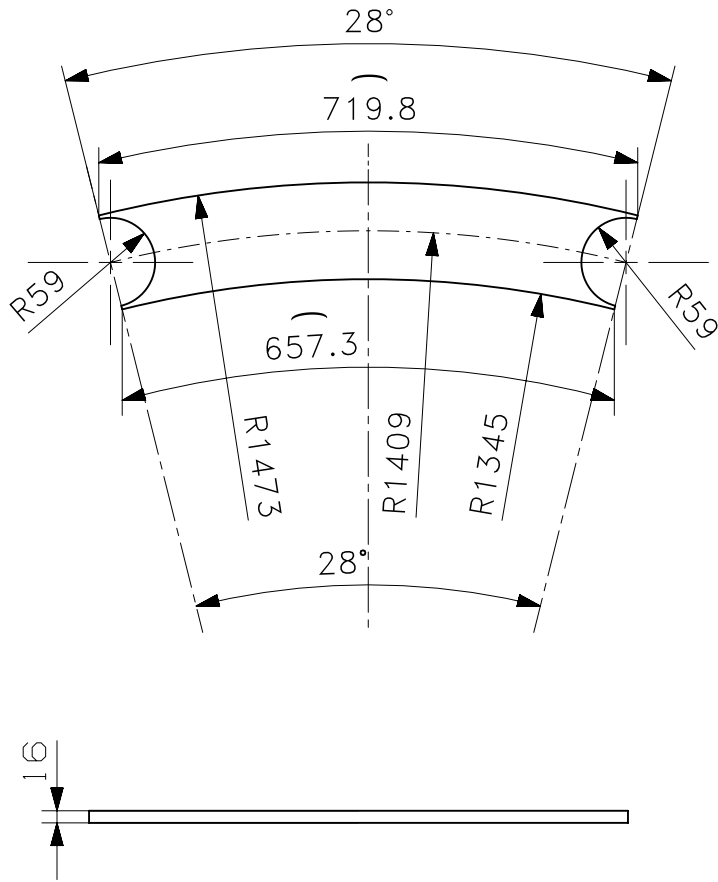

DESCRIPTION & DRG.NO.	VAR NO.	PL: 16	AA1011819112	13.13	
			AA10119	6	
		RAW MATERIAL SIZE OR CASTING DRG.NO. OR FORGING DRG.NO.	MATL. CODE	NET.WT.	GROSS WT
			MATL. SPECN.	QTY.	

TYPE OF PRODUCT OR NAME OF CUSTOMER/PROJECT: TARI-930-30P

	BHARAT HEAVY ELECTRICALS LTD. HYDERABAD		NAME	SIGN	DATE	NO.OF VAR.	
	DRN.	A.PRAMODH	ASSEMBLED		22.01.16		NA
	CKD.	M.ASIM			22.01.16		
APPD.	K.C.PANDA			22.01.16			

DEPT. EME		SCALE N.T.S	WEIGHT(K.G.) 13.13	REF.TO ASSY.DRG. 21350131327	ITEM NO. 3	NO.OF ITEM NA
CODE 425						
TITLE SUPPORT PLATE BETWEEN PIPES				DRAWING NO. 4-135-01-34093	REV. 00	

THE INFORMATION ON THIS DOCUMENT IS THE PROPERTY OF BHARAT HEAVY ELECTRICALS LIMITED. IT MUST NOT BE USED DIRECTLY OR INDIRECTLY IN ANY WAY DETRIMENTAL TO THE INTEREST OF THE COMPANY.

25 ✓

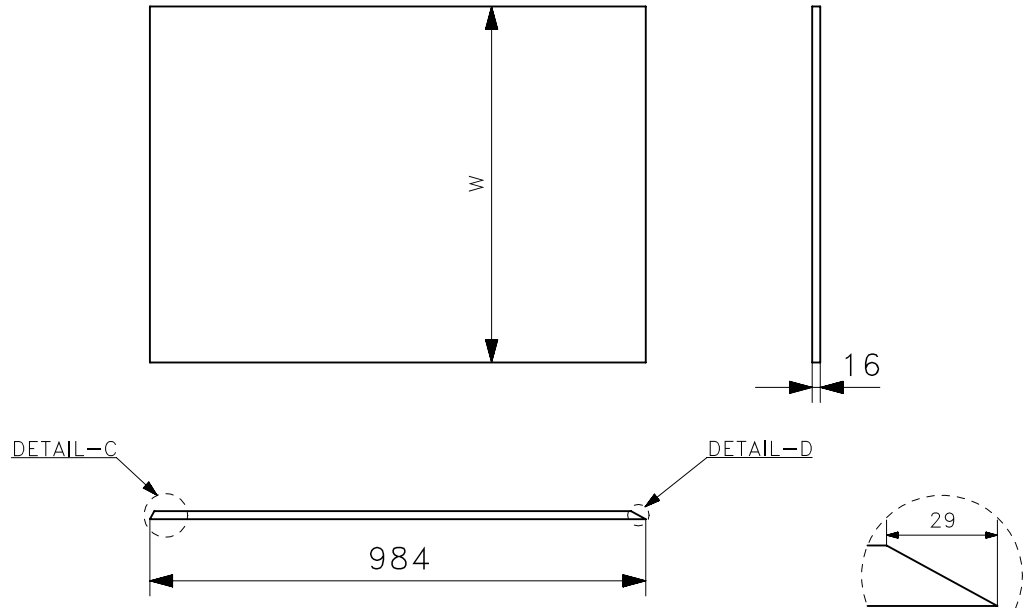

VAR NO	W	WT KG.	Qty
01	605	73.5	4
02	707	85.5	4

INVENTORY NO. SIGN. & DATE (REF. DRG. NO. COMPUTER NO.)

		PL: 16	AA1011819112	TABLE	
			AA10119	REF. TABLE	
DESCRIPTION & DRG.NO.	VAR NO.	RAW MATERIAL SIZE OR CASTING DRG.NO. OR FORGING DRG.NO.	MATL. CODE	NET.WT.	GROSS WT
			MATL. SPECN.	QTY.	

TYPE OF PRODUCT OR NAME OF CUSTOMER/PROJECT: TARI 930-30P

	BHARAT HEAVY ELECTRICALS LTD. HYDERABAD		NAME	SIGN	DATE	NO.OF VAR. NA
	DRN.	A.PRAMODH	ASIM/PRAMODH		14.01.16	
	CKD.	M.ASIM			14.01.16	
APPD.	K.C.PANDA			14.01.16		

DEPT. EME		SCALE N.T.S	WEIGHT(K.G.) SEE TABLE	REF.TO ASSY.DRG. 01350131205	ITEM NO. 7,8	NO.OF ITEM NA
CODE 425		TITLE TRIANULAR DUCT COVERS	DRAWING NO. 41350134094	REV. 00		

THE INFORMATION ON THIS DOCUMENT IS THE PROPERTY OF BHARAT HEAVY ELECTRICALS LIMITED. IT MUST NOT BE USED DIRECTLY OR INDIRECTLY IN ANY WAY DETRIMENTAL TO THE INTEREST OF THE COMPANY.

REV.	DATE	ALTERED	A.PRAMODH	REV.	DATE	ALTERED	REV.	DATE	ALTERED
01	20.06.16	CHECKED	M.ASIM			CHECKED			CHECKED
		APPROVED	K.C.PANDA			APPROVED			APPROVED

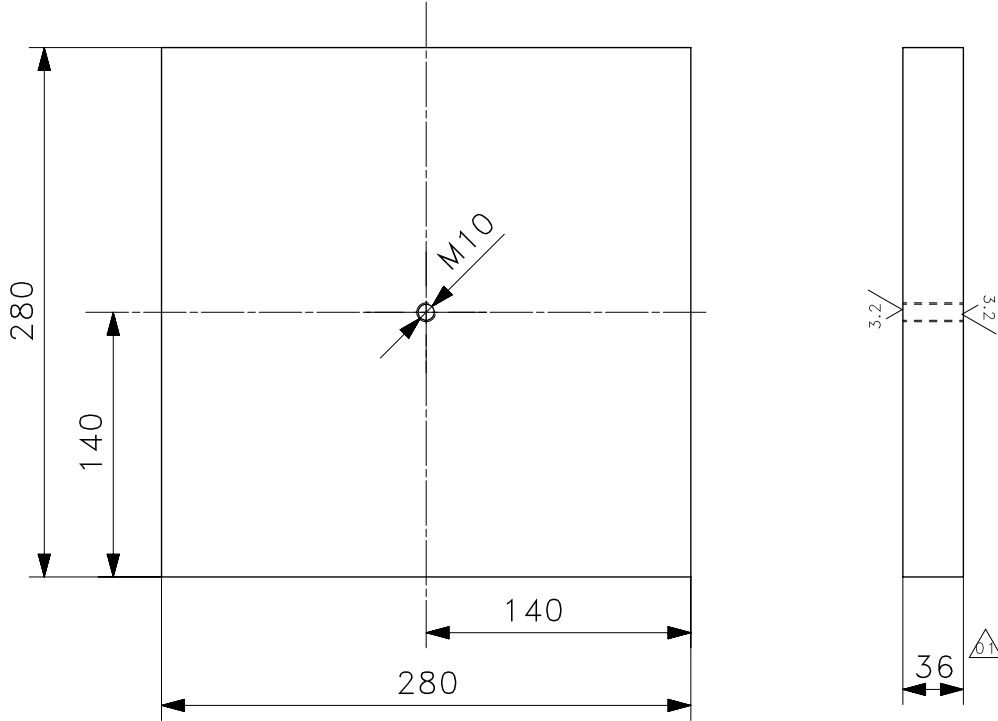

DIMENSION 36 CHANGED TO 32 MM.

6.3 ✓



		PL: 36	AA1011819180	21.50	
			AA10119	4	
DESCRIPTION & DRG.NO.	VAR NO.	RAW MATERIAL SIZE OR CASTING DRG.NO. OR FORGING DRG.NO.	MATL. CODE	NET.WT.	GROSS WT
			MATL. SPECN.	QTY.	

TYPE OF PRODUCT OR NAME OF CUSTOMER/PROJECT: TARI-930-30P

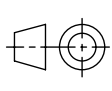
REF. TO HY023026 FOR UNSPECIFIED TOLERANCES  BHARAT HEAVY ELECTRICALS LTD. HYDERABAD	DRN.	A.PRAMODH	SIGN	DATE	NO.OF VAR. NA	
	CKD.	M.ASIM		13.01.16		
	APPD.	K.C.PANDA		13.01.16		
DEPT. EME		SCALE NTS	WEIGHT(K.G.) 21.50	REF.TO ASSY.DRG. 01350131206	ITEM NO. NA	NO.OF ITEM NA
CODE 425	TITLE TOP CORNER PLATE FOR FOUNDATION			DRAWING NO. 41350134095	REV. 01	

REV.	DATE	ALTERED	REV.	DATE	ALTERED	REV.	DATE	ALTERED
		CHECKED			CHECKED			CHECKED
		APPROVED			APPROVED			APPROVED

THE INFORMATION ON THIS DOCUMENT IS THE PROPERTY OF BHARAT HEAVY ELECTRICALS LIMITED. IT MUST NOT BE USED DIRECTLY OR INDIRECTLY IN ANY WAY DETRIMENTAL TO THE INTEREST OF THE COMPANY.

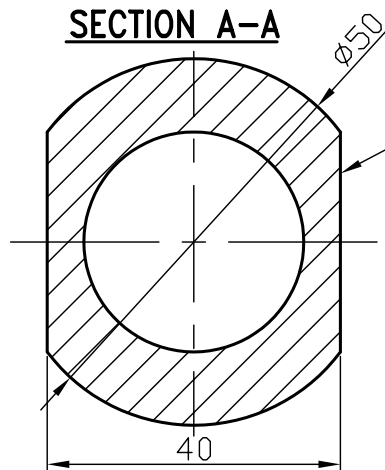
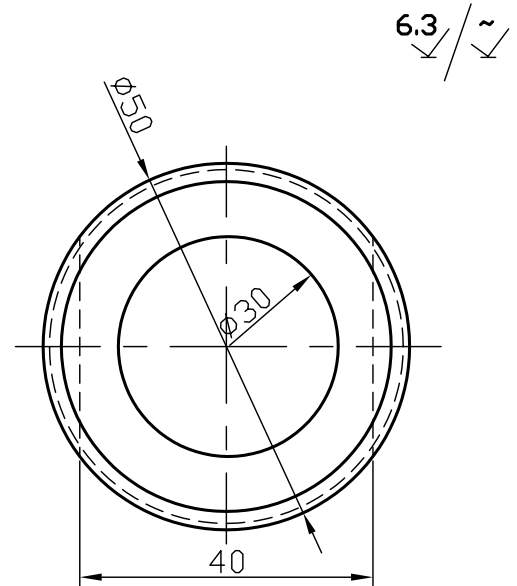
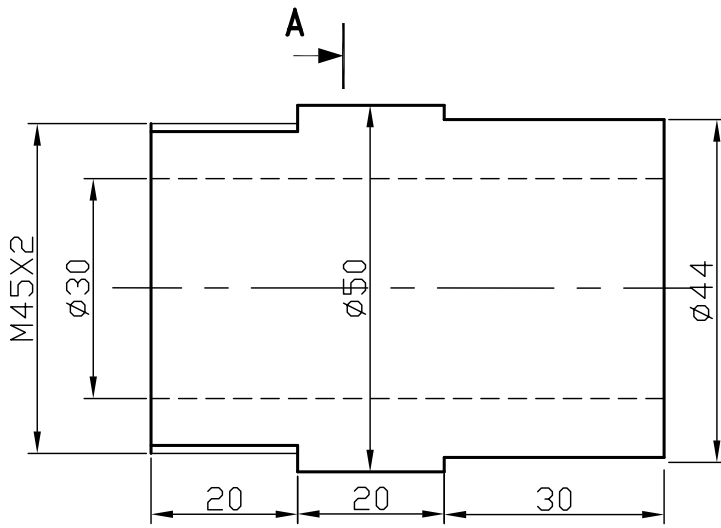

COMPUTER NO. 4AB31344		R0:50	AA1020208180	0.74	
REF. DRG. NO.	VAR NO.	RAW MATERIAL SIZE OR CASTING DRG.NO. OR FORGING DRG.NO.	AA10208	16	
DESCRIPTION & DRG.NO.			MATL. CODE	NET.WT.	GROSS WT
			MATL. SPECN.	QTY.	

TYPE OF PRODUCT OR NAME OF CUSTOMER/PROJECT: **TARI 1080-36Q**

INVENTORY NO. REF. TO HY0230 UNSPECIFIED TO	DEPT. EME CODE 425		SCALE 1:1	WEIGHT(K.G.) 0.74	NAME	SIGN	DATE	NO.OF VAR. -NA-
					DRN. SHAUKAT		27.08.10	
					CKD. GCS REDDY		27.08.10	
TITLE CONNECTOR		REF.TO ASSY.DRG. NA		ITEM NO. NA	NO.OF ITEM NA	DRAWING NO. 4-139-06-31831		REV. 00
				SHT.NO. 01	NO.OF SHT. 01			



RESTRICTED USE