

THE INFORMATION ON THIS DOCUMENT IS THE PROPERTY OF BHARAT HEAVY ELECTRICALS LIMITED.  
IT MUST NOT BE USED DIRECTLY OR INDIRECTLY IN ANY WAY DETRIMENTAL TO THE INTEREST OF THE COMPANY.

INVENTORY NO.	SIGN. AND DATE	REF. DRG. NO.
---------------	----------------	---------------

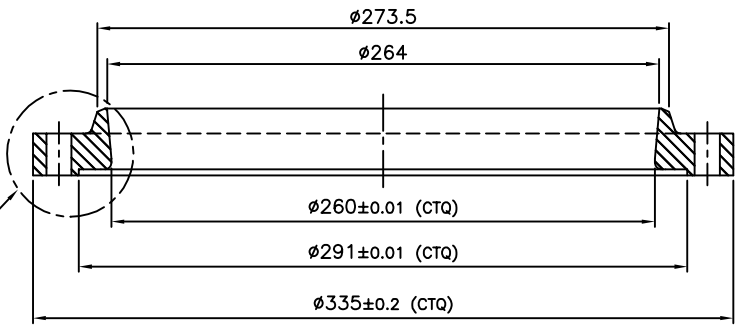

SECTION-AA

REFER DETAIL-A

FINISH:- INSIDE GROOVE Rø1.6  
CTQ:- CRITICAL TO QUALITY

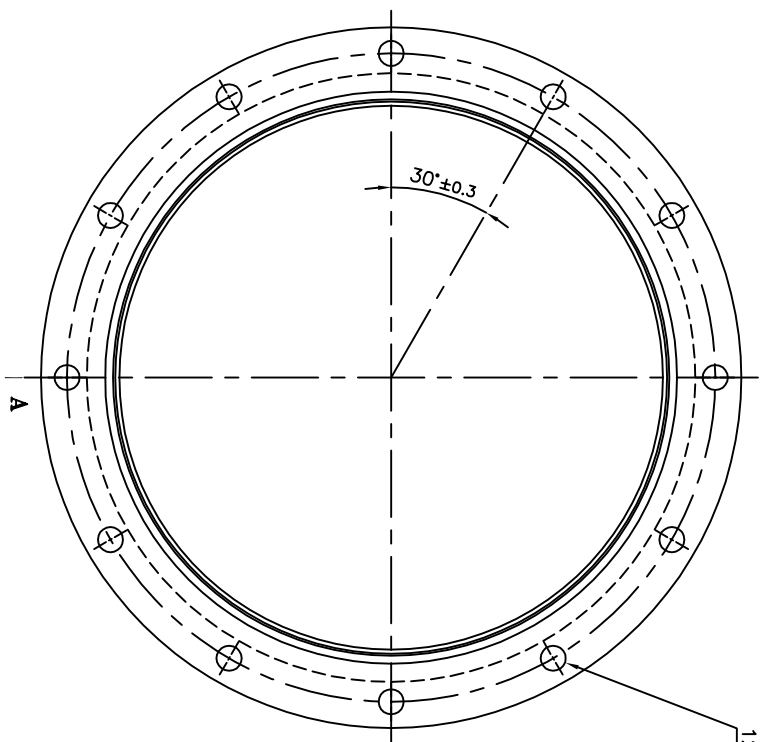

12 HOLES  $\phi 12$  ON PCD  $310\pm 0.5$  (EQUALLY SPACED)  
AND  $0.5\times 45^\circ$  CHAMFERED ON BOTH FACES  
(CTQ)

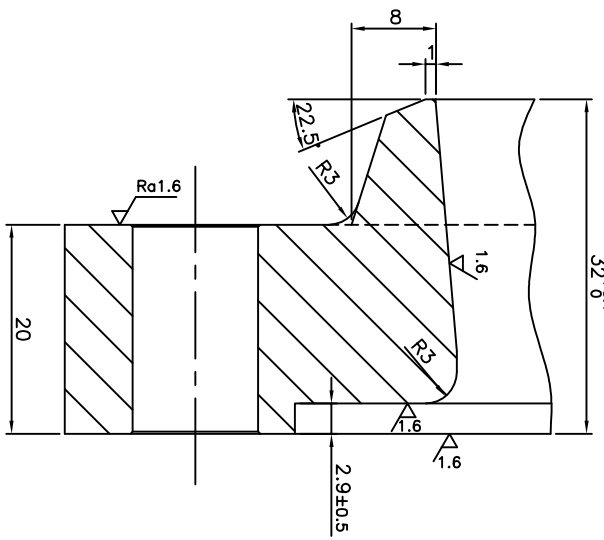

DETAIL-A

VAR. NO.	REMARKS	VAR. ITEM NO.	DESCRIPTION	STD.	DRAWING NO.	TT. NO.	MATL. CODE	A	UNIT	QTY.	ZONE
							SS-304L				

TYPE OF PRODUCT  
NAME OF CUSTOMER  
GSM-145

DEPT.	ISSUE OF	SCALE	WEIGHT(KG)
BHARAT HEAVY ELECTRICALS LTD.	HYDERABAD	NTS	

REV.	DATE	ALTERED	REV.	DATE	ALTERED
ZONE		CHECKED	ZONE		CHECKED

DN	NAME	SIGN.	DATE	NO. OF
CD	SA		07/06/13	VAR.
APPD	MMRAO		07/06/13	
REF. TO				

CARD CODE	DRAWING NO.	SHEET NO.	NO. OF SHEETS
3 520 75	12100		

FLANGE