

- NOTE:**
1. PIPE AND FLANGE TO BE TIG/MIG WELDING WITH SUITABLE SS ELECTRODE
 2. THE ROOT SHOULD BE HOMOGENEOUS AND CONTINUOUS.
 3. TESTED ASSEMBLIES TO BE DEGREASED, SAND BLASTED AND POWDER COATED ON OUTSIDE.
 4. MAINTAIN PERPENDICULARITY AND PARALLARITY BETWEEN FLANGES WITHIN 0.1°
 5. INNER SURFACE OF ENCLOSURE SHALL BE ELECTROPOLISHED.

VAR NO	REMARKS	VAR NO	ITEM NO	DESCRIPTION	DRWING NO	ITM NO	MATL CODE	MATL SPECN	UNIT	QTY
01			01	FLANGE LGS	RD DG 4 35 0617 0051		SS-304 L		01	
02			02	PIPE	RD DG 4 35 0617 0051		SS-304 L		01	
03			03	FLANGE CABLE	RD DG 4 35 0617 0052		SS-304 L		01	
04			04	FLANGE IV	RD DG 4 35 0617 0212B		SS-304 L		01	

TYPE OF PRODUCT: GSM 420
NAME OF CUSTOMER: BHARAT HEAVY ELECTRICALS LTD. HYDERABAD

REV.	DATE	ALTERED	REV.	DATE	ALTERED
		CHECKED			CHECKED

DEPT.	GRADE OF	SCALE	WEIGHT(KG)	DRW NAME	SIGN.	DATE	NO. OF
	1/4"	NTS	315.5			21/05/16	01

TITLE	CAD CODE	DRAWING NO.	SHEET NO.	NO. OF SHEETS
CABLE TERMINATION ENCLOSURE		RD DG 4 35 0617 0050		

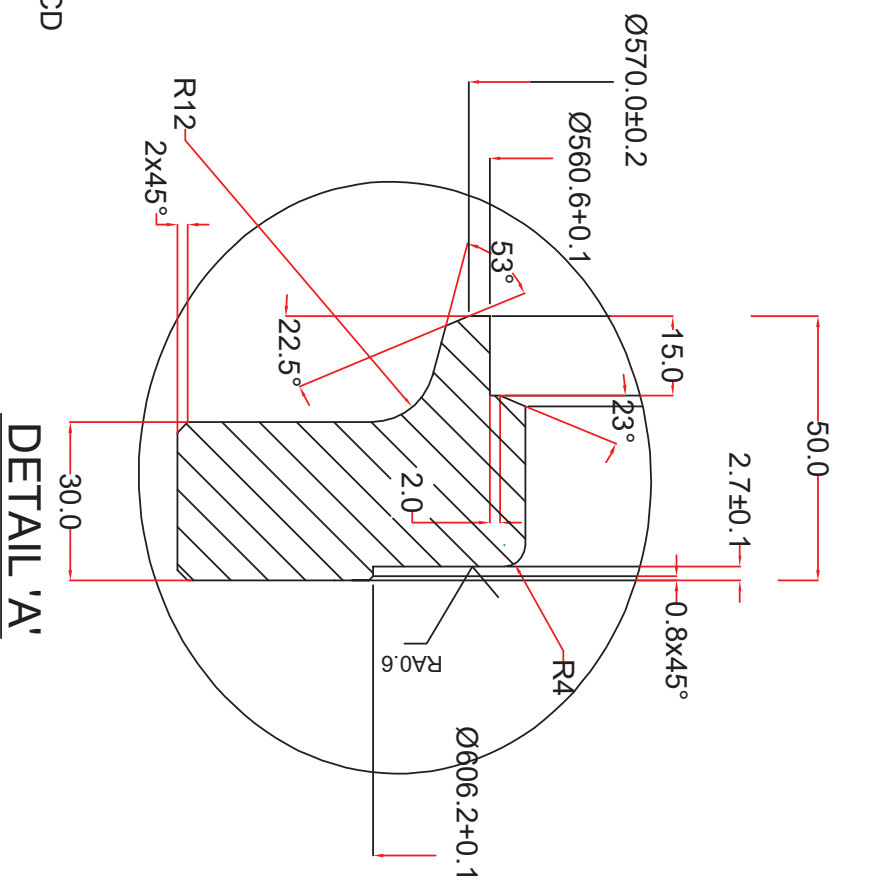
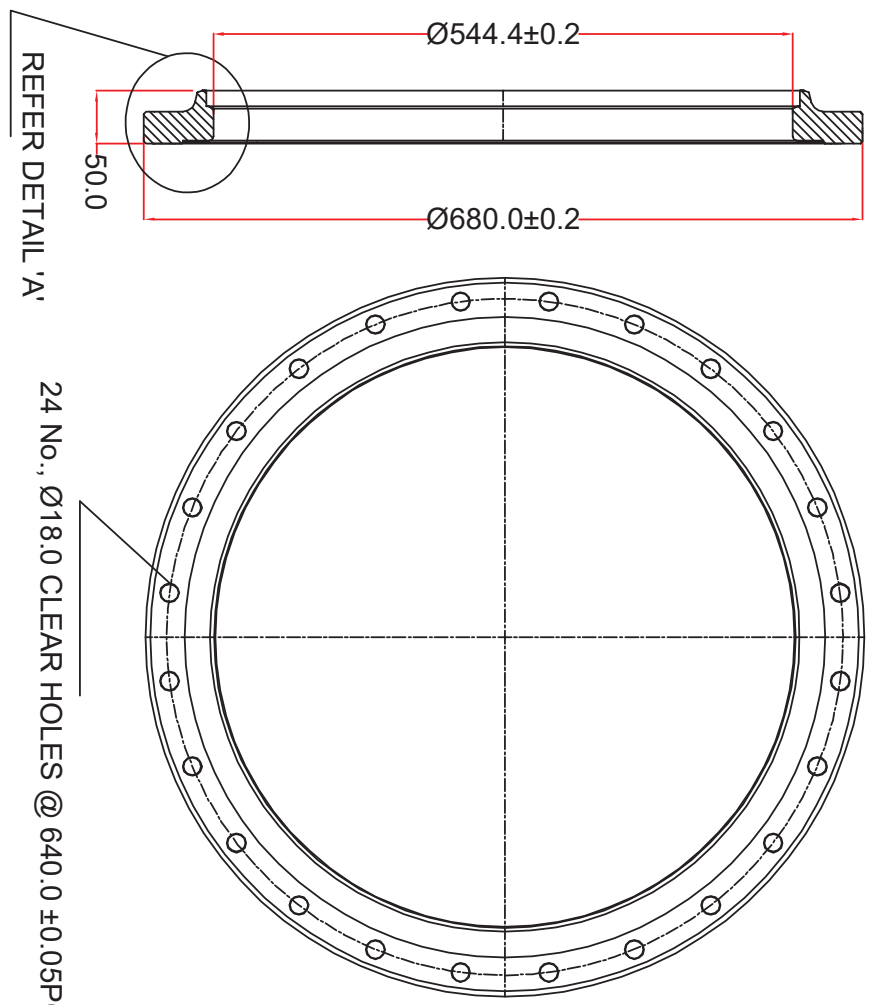

24 No., Ø18.0 CLEAR HOLES @ 640.0 ±0.05PCD

Note:

1. Sealing area shall be polished to RA 0.8 or better.
2. Ø 18.0 holes shall be chamfered uniformly (0.8x45°).
3. PCD and flange centre shall be concentric within ±0.1
4. Finished flange shall be degreased and packed in 125 micron poly bag and sealed.
5. Component shall be Machined to dimensions after welding to spherical pipe

FINAL ON 10/05/10

VAR NO.	REMARKS	VAR NO.	ITEM NO.	DESCRIPTION	DRG NO.	LT NO.	MATL CODE	MATL SPECN.	UNIT WGT.	QTY.
01				SS FLANGE					45.0 KG	02

TYPE OF PRODUCT		NAME OF CUSTOMER		SIGN.		DATE		IND. OF	
GSM-420		BHARAT HEAVY ELECTRICALS LTD.		MM RAO		21/05/10		VAR.	
NAME OF CUSTOMER		HYDERABAD		DRN		MB		DATE	
DEPT.		GRADE OF		APPD		MM RAO		21/05/10	
CODE		TOL. DIM.		REF. TO		RD DG 4 35 0617 0950		ITEM NO. OF	
		C/M/V		SCALE		NTS		NO. ITEMS	
		SCALE		WEIGHT(KG)		45.0 KG		1	
		CADD		DRAWING NO.		RD DG 4 35 0617 0951		REV.	
		SHEET NO.		IND. OF SHEETS					

REV.	DATE	ALTERED	REV.	DATE	ALTERED
		CHECKED			CHECKED

INVENTORY NO.	SIGN. AND DATE	REF. DRG. NO.

THE INFORMATION ON THIS DOCUMENT IS THE PROPERTY OF IT MUST NOT BE USED DIRECTLY OR INDIRECTLY IN ANY WAY DETRIMENTAL TO THE INTEREST OF THE COMPANY.

INVENTORY NO.	SIGN. AND DATE	REF. DRG. NO.
---------------	----------------	---------------

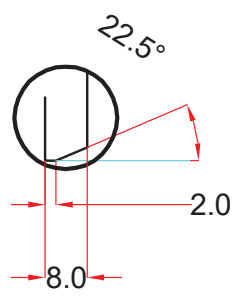
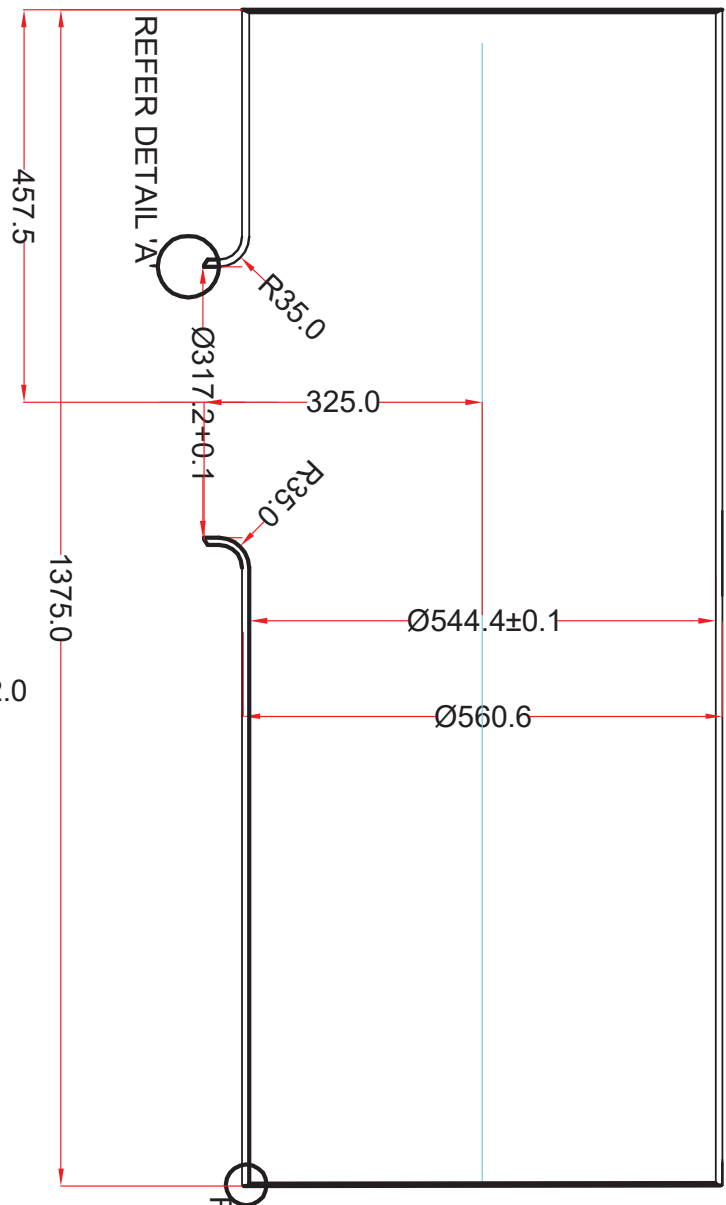

DETAIL 'A' & 'B'

NOTE:
PIPE TO BE DRILLED TO SUIT TO FLANGE IV (FOR WELDING)

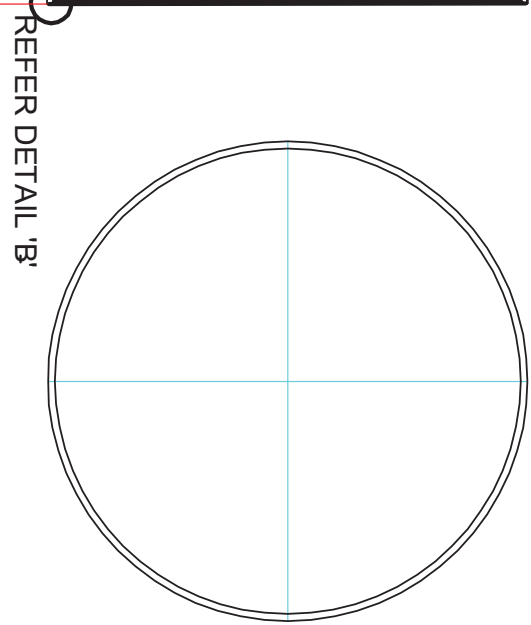

REFER DETAIL 'B'

VAR. NO.	REMARKS	VAR. NO.	ITEM NO.	DESCRIPTION	STD.	DRAWING NO.	IT. NO.	MATL. CODE	A	UNIT	UNIT WGT.	QTY.	SI
		01		PIPE				SS-304L			01		

TYPE OF PRODUCT
NAME OF CUSTOMER
GSM 420

DEPT. CODE	GRADE OF PIPE	SCALE	WEIGHT(KG)	DRN. NO.	NAME	SIGN.	DATE	IND. OF
35	5/4"	NTS		48			21.05.18	VAR.

REV.	DATE	ALTERED	REV.	DATE	ALTERED
		CHECKED			CHECKED

TITLE	CARD CODE	SHEET NO.	IND. OF SHEETS
PIPE	RD DG 4 35 0617 0051		

THE INFORMATION ON THIS DOCUMENT IS THE PROPERTY OF
IT MUST NOT BE USED DIRECTLY OR INDIRECTLY IN ANY WAY DETRIMENTAL TO THE INTEREST OF THE COMPANY.

INVENTORY NO.	SIGN. AND DATE	REF. DRG. NO.
---------------	----------------	---------------

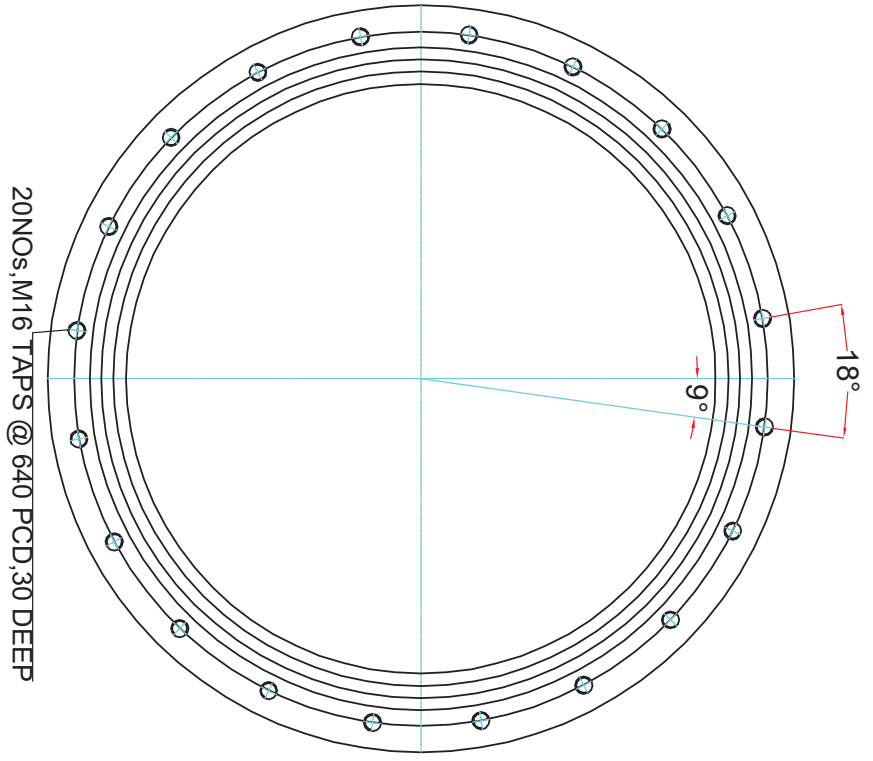

20 NOS, M16 TAPS @ 640 PCD, 30 DEEP

- NOTE:
1. SEALING AREA SHALL BE POLISHED TO RA 0.6 OR BETTER.
 2. PCD AND FLANGE CENTRE SHALL BE CONCENTRIC WITHIN ±0.05
 3. ALL SHARP EDGES SHALL BE MACHINED TO 0.4X45°.
 4. COMPONENT SHALL BE MACHINED TO DIMENSIONS AFTER WELDING TO PIPE.

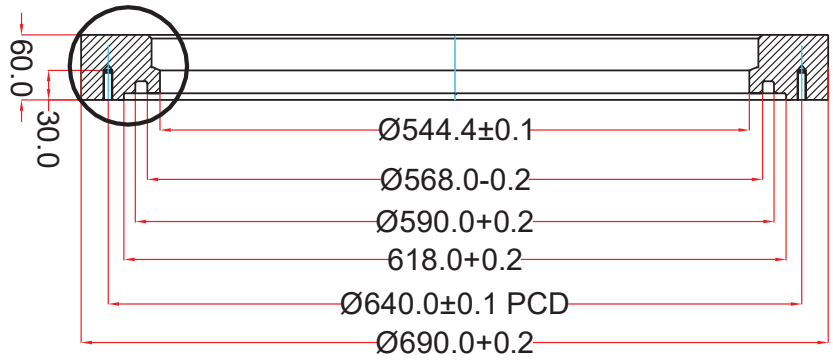

REFER DETAIL 'A'

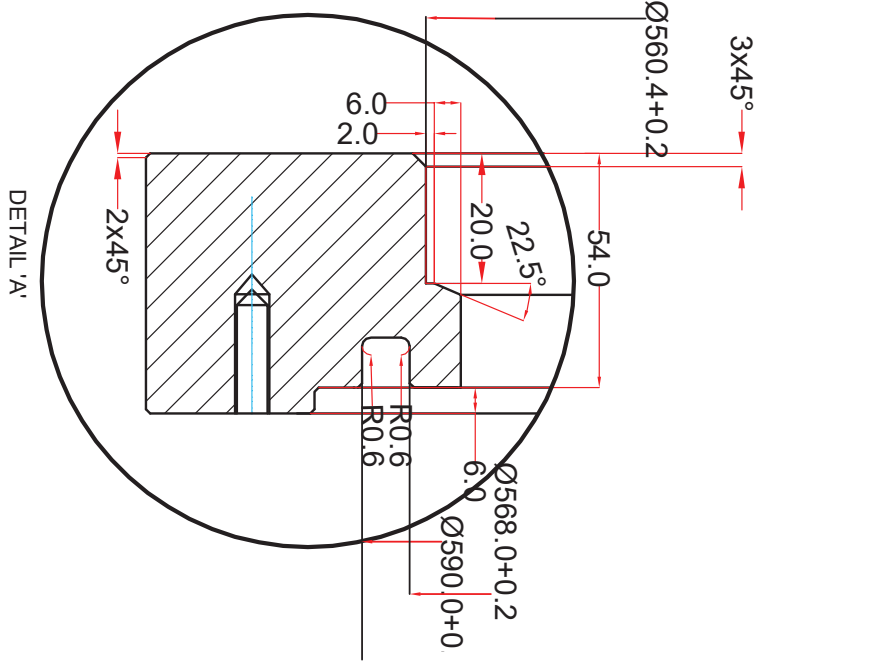

DETAIL 'A'

VAR ID	REMARKS	VAR NO.	ITEM NO.	DESCRIPTION	STD	DRAWING NO.	ITM NO.	MATL CODE	MATL SPECN.	A UNIT	C UNIT	QTY	SI
			01	BLOCK				SS-304L					01

TYPE OF PRODUCT
NAME OF CUSTOMER
GSM 420

DEPT. CODE	GRADE OF TOOL DIM.	SCALE	WEIGHT(KG)	DRN NO.	NAME	SIGN.	DATE	IND. OF V.A.R.
35	5/4	NTS		18	BH		21.05.18	
BHM HYDERABAD		BH		21.05.18				

REV.	DATE	ALTERED	REV.	DATE	ALTERED
CHECKED			CHECKED		

TITLE	CHD CODE	SHEET NO.	IND. OF SHEETS
FLANGE_CABLE	RD DG 4 35 0617 0050	RD DG 4 35 0617 0052	

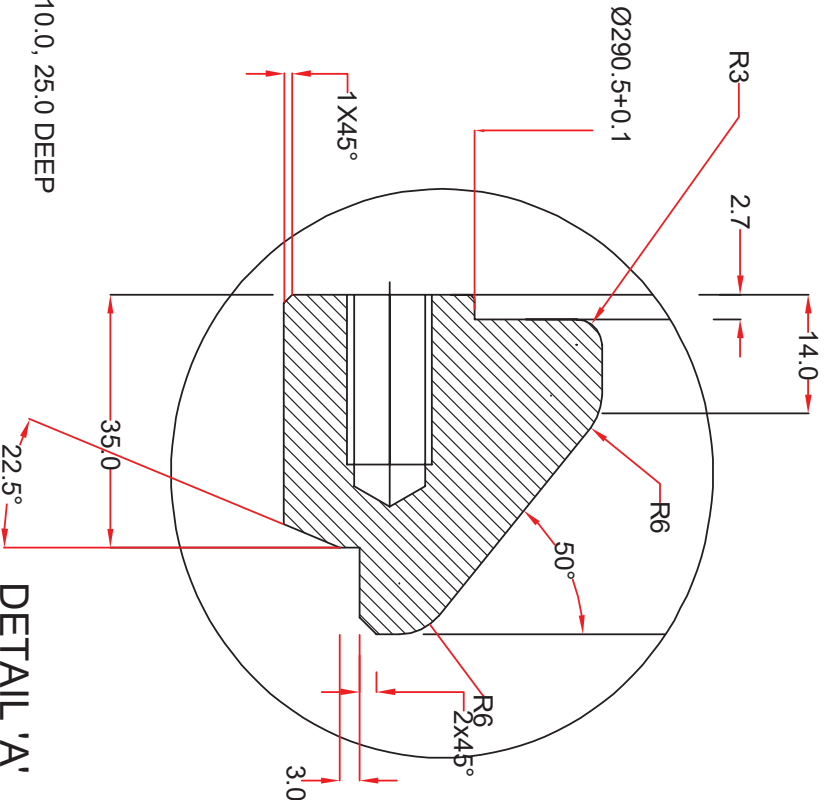
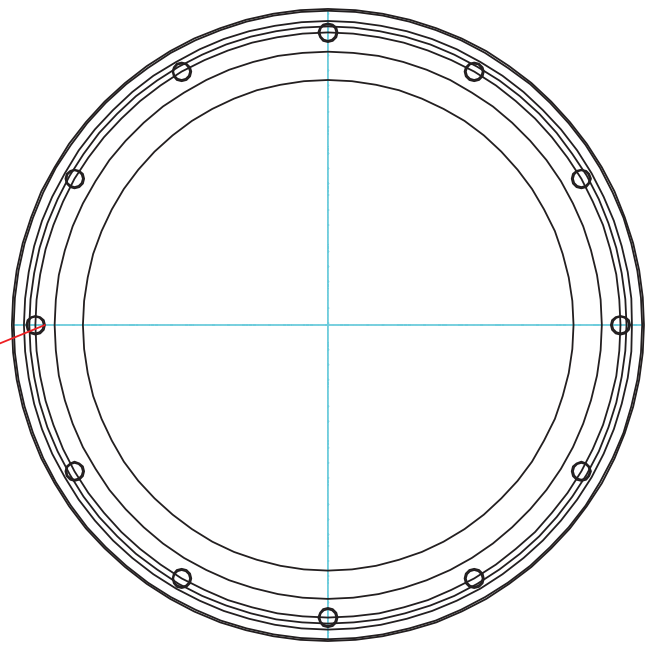
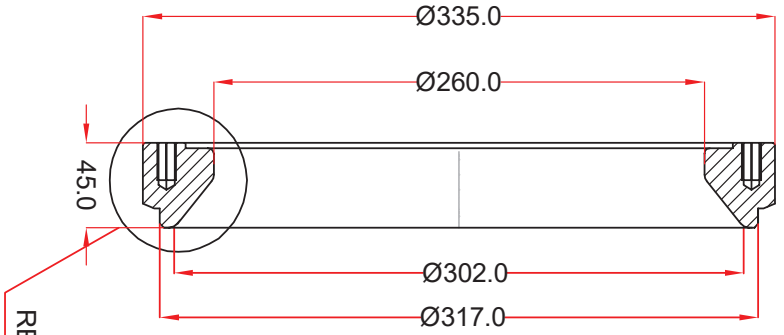

REFER DETAIL 'A'

12 No., M10 TAPS @ 310.0, 25.0 DEEP

DETAIL 'A'

INVENTORY NO.	SIGN. AND DATE	REF. DRG. NO.
---------------	----------------	---------------

THE INFORMATION ON THIS DOCUMENT IS THE PROPERTY OF BHARAT HEAVY ELECTRICALS LIMITED. IT MUST NOT BE USED DIRECTLY OR INDIRECTLY IN ANY WAY DETRIMENTAL TO THE INTEREST OF THE COMPANY.

ALL SHARP EDGES SHALL BE MACHINED TO 0.4X45°

REV.	DATE	ALTERED	REV.	DATE	ALTERED
ZONE		CHECKED	ZONE		CHECKED

VAR NO.	REMARKS	VAR NO.	ITEM NO.	DESCRIPTION	QTY	SS-304	35.0
		01		FLANGE	01		

TYPE OF PRODUCT: **GSM-400**

NAME OF CUSTOMER: **BHARAT HEAVY ELECTRICALS LTD. HYDERABAD**

DEPT. CODE: **NTS**

SCALE: **1:1.0**

DRW. NO.: **RD DG 4 35 0617 0212B**

DATE: **21.05.18**

APPD. NAME: **MIRAO**

ITEM NO.: **01**

TITLE: **FLANGE**

CAD CODE: **RD DG 4 35 0617 0212B**

SHEET NO.: **1**

IND. OF SHEETS: **1**