

66900-102-02-3-20-201-00699  
DRAWING NO.

12.5 / ( 0.8 / 1.6 / 3.2 )

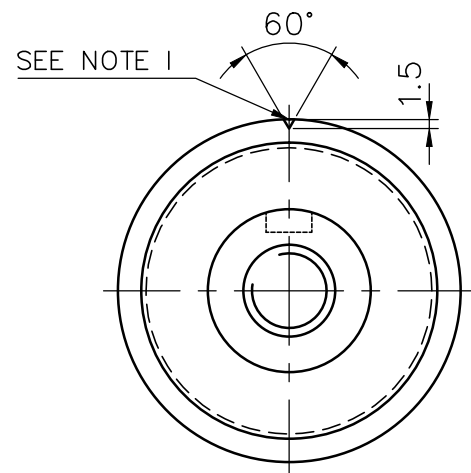

VIEW 'P'

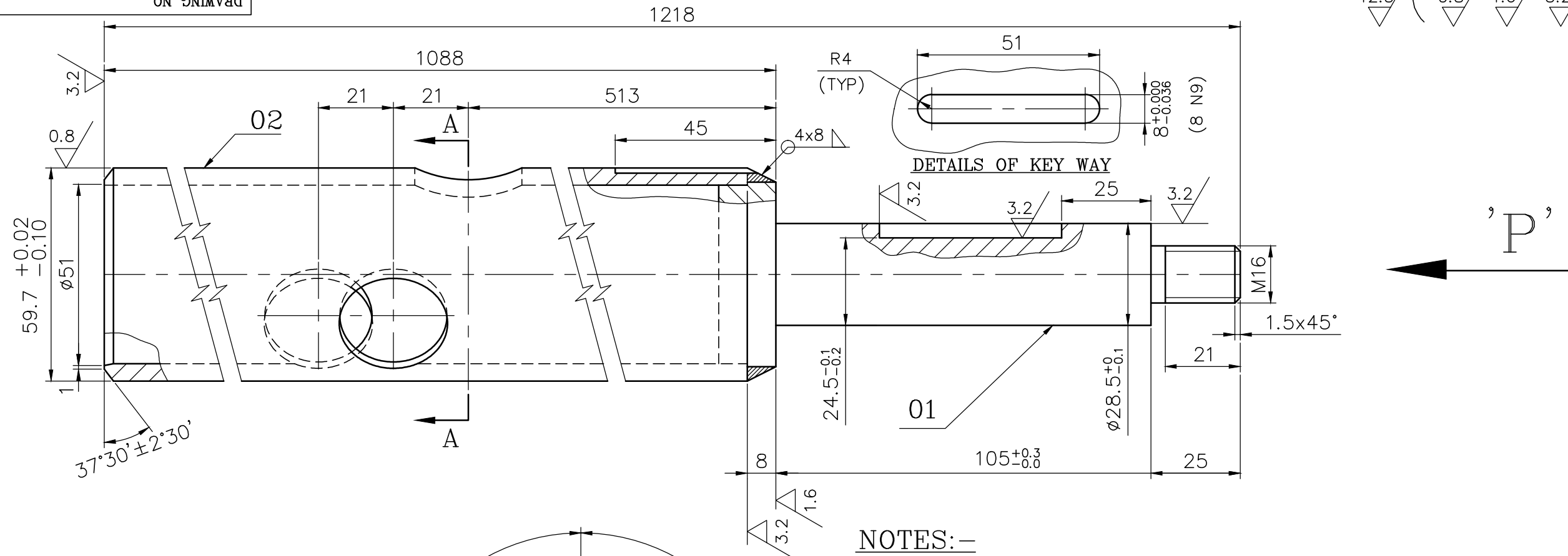
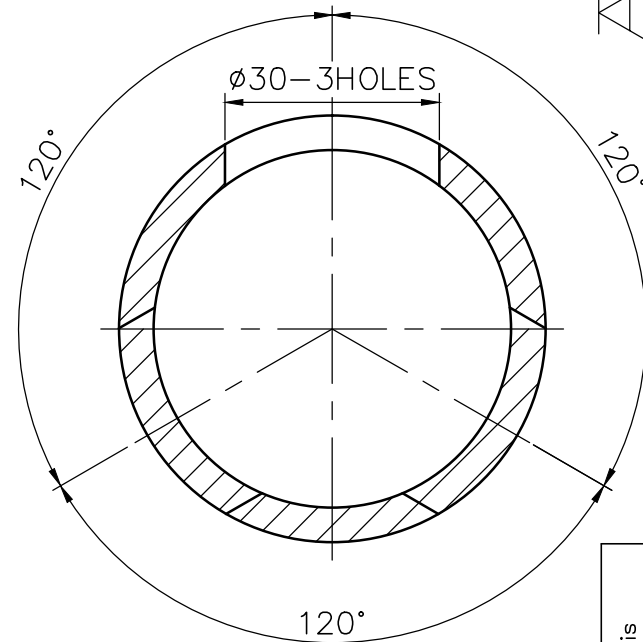

SECTION - 'AA'

NOTES:-

- 'V' GROOVE TO BE IN LINE WITH CENTER LINE OF KEY WAY.
- ALL MACHINING SHOULD BE DONE AFTER WELDING OF ITEM 01 AND 02.
- FOR QUALITY REQUIREMENTS REFER LATEST APPLICABLE QUALITY PROCEDURES.

PART CODE : 842020135500

NO OFF	DESCRIPTION	MATL CODE	MATL SPECN	HEAT TREATMENT	SCRAP SORT	NET WT (kg)	GROSS WT (kg)	DRAWING No	ITEM No
--------	-------------	-----------	------------	----------------	------------	-------------	---------------	------------	---------

TYPE OF PRODUCT  
OR NAME OF  
CUSTOMER/PROJECT

 BHARAT HEAVY ELECTRICALS LTD., UNIT: HIGH PRESSURE BOILER PLANT. TIRUCHIRAPALLI-620014. 365-121	DRN	V.ARUMUGAM	V.A	DATE	11.06.01	NO. OF VAR.
	CHD	K.SRIDHARAN	K.S	DATE	11.06.01	
	APPD	S.NATARAJAN	S.N	DATE	11.06.01	

DEPT	SB	SCALE	WEIGHT (KG).	REFERENCE INFORMATION	NO. OF ITEMS
CODE	330	NTS	8.580	M-63618 3-20-201-00139	

TITLE	CARD CODE	DRAWING NO.	REV
SEMI-FINISHED SWIVEL TUBE	U 01	3-20-201-00699	04

REV	DATE	ALTERED	J.S
04	24.08.12	CHD & APPD	K.S

KEY WAY REFERENCE PROVIDED & DRAWING UPDATED.

DCN:SB: 801294 / 5014784

CAUTION: The information on this document is the property of BHARAT HEAVY ELECTRICALS LTD. It must not be used directly or indirectly in any way detrimental to the interest of the company.

DRAWING NO. 2-20-201-00280

ALL DIMENSIONS ARE IN MILLIMETRES. FOR TOLERANCES OF UNTOLERANCED DIMENSIONS DURING MANUFACTURE REFER RELEVANT QCP / QP

NOTES: -

- VARIANT No. 02, 03 & 04 MEANT FOR COPES VULCON SWIVEL TUBE ASSEMBLY REPLACEMENT.
- FOR QUALITY REQUIREMENTS REFER LATEST APPLICABLE QUALITY PROCEDURES.
- WELD NOZZLE HEAD ASSEMBLY WITH SWIVEL TUBE IN SUCH A WAY THAT THE 'V' GROOVE PROVIDED ON SWIVEL TUBE SHOULD BE INLINE WITH THE CENTRE LINE OF NOZZLEFOR QUALITY REQUIREMENTS REFER LATEST APPLICABLE QUALITY PROCEDURES.
- VARIANT No. 05 MEANT FOR STAINLESS STEEL (SS) SWIVEL TUBE MATERIAL.
- HARD CHROME PLATING IS NOT REQUIRED FOR VARIANT No. 5 (SS SWIVEL TUBE ).

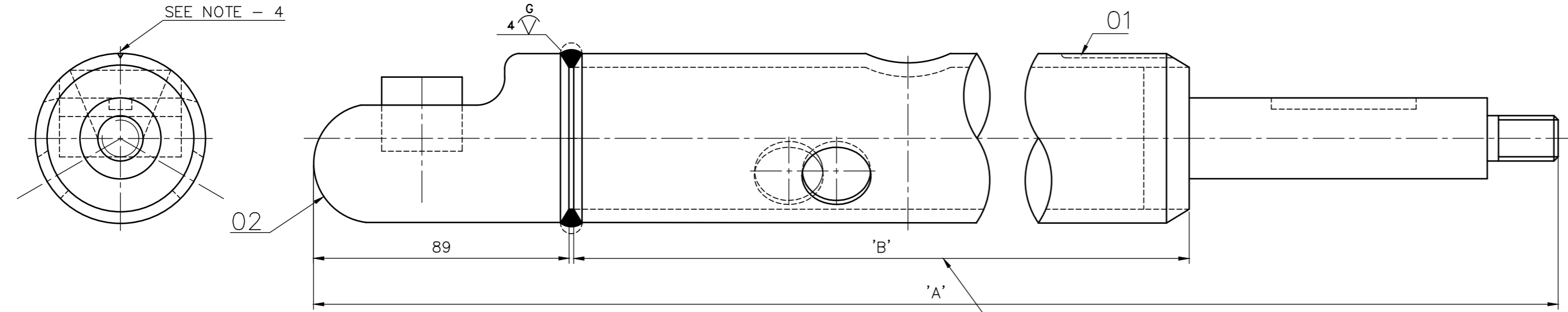

HARD CHROME PLATE THIS LENGTH 0.05 THICK TO  $\phi 59.8^{+0.02/-0.03}$

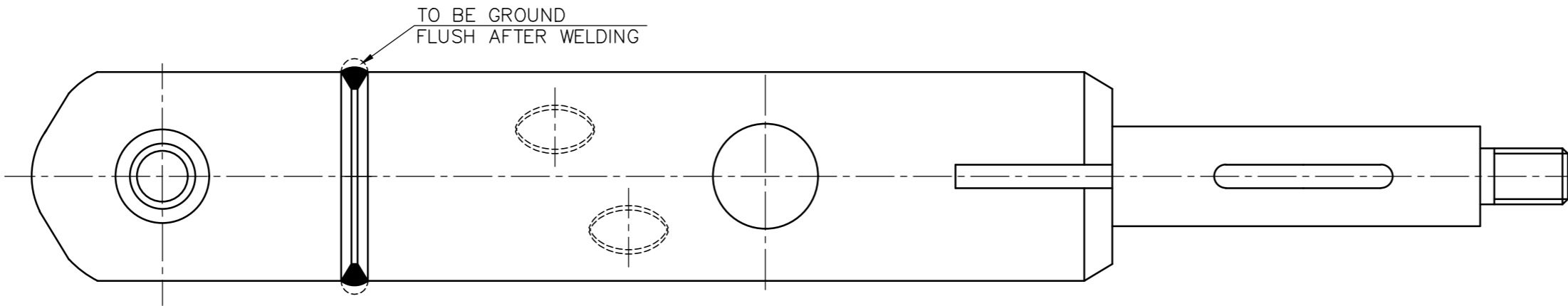

VARIANT No.	ITEM No.	DESCRIPTION	DRAWING No.	MATL. CODE	UNIT WT.(kg)	MATL. SPEC.	QTY(Nos)
02	NOZZLE HEAD ASSY.	4-20-201-00164	842020125600	WELDMENT	1	0.920	
01	SWIVEL TUBE	3-20-201-02010	842020125503	WELDMENT	1	10.120	
05	SWIVEL TUBE ASSY.(SS)	2-20-201-00280	842020125600	WELDMENT	1	0.920	
02	NOZZLE HEAD ASSY.	4-20-201-00164	842020125600	WELDMENT	1	0.920	
01	SWIVEL TUBE	3-20-201-00903	-	WELDMENT	1	8.436	
04	SWIVEL TUBE ASSY.	2-20-201-00280	842020125600	WELDMENT	1	0.920	
02	NOZZLE HEAD ASSY.	4-20-201-00164	842020125600	WELDMENT	1	0.920	
01	SWIVEL TUBE	3-20-201-00846	842020125600	WELDMENT	1	9.500	
03	SWIVEL TUBE ASSY.	2-20-201-00280	842020126400	WELDMENT	1	9.500	
02	NOZZLE HEAD ASSY.	4-20-201-00164	842020125600	WELDMENT	1	0.920	
01	SWIVEL TUBE	3-20-201-00810	-	WELDMENT	1	8.186	
02	SWIVEL TUBE ASSY.	2-20-201-00280	842020102400	WELDMENT	1	9.106	
02	NOZZLE HEAD ASSY.	4-20-201-00164	842020125600	WELDMENT	1	0.920	
01	SWIVEL TUBE	3-20-201-00699	842020135500	WELDMENT	1	8.580	
01	SWIVEL TUBE ASSY.	2-20-201-00280	842020125500	WELDMENT	1	9.500	
				MATL. CODE		UNIT WT.(kg)	
				MATL. SPEC.		QTY(Nos)	

VARIANT	DIMENSION 'A'	DIMENSION 'B'
01	1308	1088
02	1187	967
03	1308	1088
04	1221	1001
05	1308	1088

REV	DATE	ALTERED	J.S
06	31.07.15	CHD & APPD	S.K.G & H.R
ZONE	VARIANT 05 ADDED.		
DCN : SB : 801968 / 5019944			

NO OFF	DESCRIPTION	MATL CODE	MATL SPECN	HEAT TREATMENT	SCRAP SORT	NET WT (kg)	GROSS WT (kg)	DRAWING No	ITEM No	
<p>CAUTION: The information on this document is the property of BHARAT HEAVY ELECTRICALS LTD. It must not be used directly or indirectly in any way detrimental to the interest of the company.</p>										
<p>TYPE OF PRODUCT OR NAME OF CUSTOMER/PROJECT</p>										
<p>BHARAT HEAVY ELECTRICALS LTD., UNIT: HIGH PRESSURE BOILER PLANT. TIRUCHIRAPALLI-620014.</p>				DRN	J.SANKAR	SIGN	J.S	DATE	10.07.12	NO.OF VAR.
				CHD	S.K.GUPTA	S.K.G		10.07.12		
				APPD	K.SRIDHARAN	K.S		10.07.12		
DEPT	SB	SCALE	NTS	WEIGHT (KG)	REFERENCE INFORMATION					
CODE	330				2-20-201-00066					
TITLE							CARD CODE	DRAWING NO.	REV	
SWIVEL TUBE ASSEMBLY							U 01	2-20-201-00280	06	