

  <p>ISO 9001, ISO 14001, OHSAS 18001 &SA8000 Certified Company</p> <p>SubContract and Purchase Department.</p>	<p>भारत हेवी इलेक्ट्रिकल्स लिमिटेड (भारत सरकार का उपक्रम) BHARAT HEAVY ELECTRICALS LIMITED (A Govt. of India Undertaking) पावर सेक्टर, उ.क्षे.परिसर, प्लाट नं.25, सेक्टर-16ए, पोस्ट बॉक्स सं.55,नोएडा-201301, Power Sector-Northern Region, Plot no.25, Sector 16 A, Noida -201301 Ph : 0120-2416500/2416292 , Fax: 0120-2416528 / 2416525 E-mail: cs@bhelpsnr.co.in ; rksingh@bhelpsnr.co.in</p>
---	---

E-TENDER ENQUIRY NO. & DATE	BHEL/PSNR/SCP/CS/E-2816(E-Tender) & DATE: 22.07.2016
DUE DATE & TIME OF TENDER SUBMISSION	01.08.2016 AT 13:30 HRS
DUE DATE & TIME OF OPENING OF TENDER	01.08.2016 AT 15:30 HRS

TENDER ENQUIRY

BHEL Power Sector, Northern Region invites sealed quotation for the following Store in **two part bid** system THROUGH E-PROCUREMENT PORTAL <https://bheleps.buyjunction.in> ONLY;

DESCRIPTION OF STORE	DESTINATION FOR SUPPLY	QTY.	DELIVERY SCHEDULE
ITEMS REQUIRED FOR MILL REJECT SYSTEM (MRS) PACKAGE	BHEL – PSNR JHAJJAR SITE	AS PER PART – B OF TENDER	WITHIN 01 MONTHS FROM DATE OF P.O.

DELIVERY REQUIRED AT - CONSIGNEE:

CONSTRUCTION MANAGER, BHEL-SITE OFFICE, INDIRA GANDHI SUPER THERMAL POWER PROJECT, P.O. – JHARLI, DISTT.- JHAJJAR, HARYANA – 124141.

IMPORTANT NOTE:

This is an E-tender floated online through our E-Procurement Site <https://bheleps.buyjunction.in>. The bidder should respond by submitting their offer online only in our e-Procurement platform at <https://bheleps.buyjunction.in>. Offers are invited in two-parts only. No Hard copy bid or bids through email/ fax shall be accepted.

The Tender Document comprise of following;

- PART – ‘A’: QUALIFYING REQUIREMENT (QR)
- PART – ‘B’: ITEM DESCRIPTION & RELATED DRAWINGS
- PART – ‘C’: SPECIAL CONDITIONS OF CONTRACT (SCC)
- PART – ‘D’: UNPRICE FORMAT
- PART – ‘E’: PRICE SCHEDULE
- PART - ‘F’ : GENERAL CONDITION OF CONTRACT (GCC) Rev. – 00 Dtd. 24.08.2015

PRE-QUALIFYING REQUIREMENTS (PQRs)

- Bidder's Average annual Turnover in last three financial years shall be at least **Rs. 10.39 lakhs.**

Note:

- In case annual accounts of last FY are not audited, then bidder should submit the audited annual accounts of previous three FY.
- In case audited annual accounts have not been submitted for all the three years as indicated above, then the applicable audited annual accounts as submitted by the bidder against the requisite three years will be averaged for three years.

ITEM DESCRIPTION & RELATED DRAWINGS

<u>List of items required for Mill Reject System package at BHEL Jhajjar site</u>				
SL. NO	DESCRIPTION OF ITEM	QTY. (Nos.)	REMARKS	SPECIFICATION
1	20NB BALL VALVE, PNEUMATICALLY OPERATED	14	MAKE: MICROFINISH VALVES PVT LTD: GA/DRAWING ATTACHED	Ball Valves, Reduced Bore, Fire Safe to API - 607, Class - 800, Screwed Ends, Pneumatic Operated, Service - Water, Body Material - ASTM A 105, Design Pr. - 76 kg/cm2 (g), Operating Pr. - 3 kg/cm2 (g), Operating Temp. - 170°C
2	20NB GLOBE VALVE MANUALLY OPERATED	18	MAKE: SANT VALVES PVT LTD GA/DRAWING ATTACHED	GUN METAL GLOBE VALVE, SCREWED, SCREWED IN BONNET, INSIDE SCREW, RISING STEM CONFORMING TO IS:778-1984 CLASS-1; ISI MARKED, Service - Water, Body Material - Gun Metal, Operating Pr. - 3 kg/cm2
3	20NB BALL VALVE MANUALLY OPERATED	15	MAKE: MICROFINISH VALVES PVT LTD: GA/DRAWING ATTACHED	Ball Valves, Reduced Bore, Fire Safe to API - 607, Class - 800, Screwed Ends, Lever Operated, Service - Water, Body Material - ASTM A 105, Design Pr. - 76 kg/cm2 (g), Operating Pr. - 3 kg/cm2 (g), Operating Temp. - 170°C
4	50NB BUTTERFLY VALVE, PNEUMATICALLY OPERATED	6	MAKE: B.D.K ENGG INDUSTRIES LTD GA/DRAWING ATTACHED	Body material: CI-IS: 210 Gr.FG260, Working Fluid - Air, Max. Operating Pr. - 10 BAR, Max. Operating Temperature - 70°C, Body Style – Wafer
5	80NB BUTTERFLY VALVE, PNEUMATICALLY OPERATED	6	MAKE: B.D.K ENGG INDUSTRIES LTD GA/DRAWING ATTACHED	Body material: CI-IS: 210 Gr.FG260, Working Fluid - Air, Max. Operating Pr. - 10 BAR, Max. Operating Temperature - 70°C, Body Style – Wafer
6	40NB FLOW CONTROL VALVE	3	VALVE & AUX EQUIP CODE: 20T-21125 SPECIFICATION SHEET & GA ATTACHED	DRAWING ATTACHED
7	65NB CHECK VALVE	2	MAKE: LEADER VALVES LTD GA/DRAWING ATTACHED	Body material : CI-IS 210:93 Gr.25 WITH 0.30 MAX.P, Stopper Pin material : S.S. TYPE 316, Disc Material : CI-IS 210:93 Gr.25 WITH 0.30 MAX.P., Disc Holding Plate : C .C.S., Grade : ASTM A2 16:07 Gr. WCB

8	125NB, 45deg. Elbow 8D Durite (OD: 140.8mm x ID:130mm x Thick:5.40 mm min. Material - Alloy CI with minimum hardness of 400BHN	32	Elbow 8D Durite (OD: 140.8mm x ID:130mm x Thick:5.40 mm min. Material - Alloy CI with minimum hardness of 400BHN	Bidder to visit site to ensure any other technical specification required for these products to ensure the items supplied are in line with the requirement. The vendor has to ensure and guarantee interchangeability in case bidder is not able to supply item with same specification.
9	125NB, 30 deg. Elbow 8D Durite (OD: 140.8mm x ID:130mm x Thick:5.40 mm min. Material -Alloy CI with minimum hardness of 400BHN	8	Elbow 8D Durite (OD: 140.8mm x ID:130mm x Thick:5.40 mm min. Material - Alloy CI with minimum hardness of 400BHN	
10	OVERSIZED GRID 1180X1240 MM, HOLE SIZE 60X40 MM, THICKNESS 6 MM	18	Material is MS(IS 2062)	
11	AIR REGULATOR	4	MODEL NO:SR70K-8G-RGCN MAKE:SHAVO	
12	TEMPERATURE SWITCH	4	MODEL NO: T4 64 T35030 XFS XPC X89C XTW MAKE: INFOS INDUS. LTD. , GAZIABAD GA/DRAWING ATTACHED	Material - 316 SS Barstock, Capillary Matl - 316 SS with 304 SS armour, Capillary Length - 10 metre, Bulb Length - 76 mm, Bulb dia & material - 9.5 mm & SS 316, Repeatability - (+)/(-) 1% of FS, Accuracy - (+)/(-) 1% of FS, Contact Rating - 15 A 250 V AC/6A 30 V DC, Max. Temperature - 260°C
13	SOLENOID VALVE	6	Model No: 51445A-6-SB+24V-DC-22, MAKE: ROTEX AUTOMATION LTD., VADODRA GA/DRAWING OF SOLONOID VALVE ATTACHED.	Vave Type- 5/2 Internal Pilot Operated, Poppet type sub base mounted, Single solenoid valve. Body material : Aluminium, Media : Air, Seat/Seal : NBR, Working Pressure : 2 - 10 bar, Orifice - 6 mm, Flow factor : 12 lpm, Manifold connection : 1/2" NPT (F) (INLET), Manifold connection : 1/4" NPT (F) (OUTLET), Coil code : 22, Coil voltage : 24V DC, Coil Insulation : CLASS F, Coil power : 8 watt, Coil Type : PLUGIN TYPE, Degree protection : IP67
14	LEVEL PROBE	2	Type-Radio Frequency, Model No: 550 MAKE: EIP ENVIRO LEVEL CONTROLS PVT LTD Detail attached.	DRAWING ATTACHED. Alternate manufacturer: 1. Nivo Controls, Indore. 2. DK Instruments, Calcutta 3. Flow Star Engineerings In case of supply from alternate manufacturer, the supplier has to guarantee interchangeability
15	GASKET	1	CONN-8", 150#/KNFG/150#,J T#71A K DATA SHEET ATTACHED	

20 NB Ball Valve pneumatically Operated (Se. No. 1)

Ball Valves, Reduced Bore,
Fire Safe to API-607,
Class-800, Screwed Ends, Pneumatic Operated. BS EN ISO 17292

SERIES : 81-R3

MFG. STD.
BS EN ISO 17292

Hydrostatic Testing (BS:EN12266, PART-1)	
Shell	210 Kg/sq.cm
Seat	78
Pneumatic Testing BS:EN12266, PART-1)	
Seat	7 kg/sq.cm

Part No.	Part Name	Material
1	Body	ASTM A 105
2	Pipe End	ASTM A 105
32	Ball	ASTM A 276 Type 304
51	Stem (Anti-Blowout)	ASTM A 276 Type 304
54	Gland	ASTM A 276 Type 304
31	Seat	PTFE
53	Stem Seal	GRAFOIL
33	Body Seal	GRAFOIL
3	Body Stud	ASTM A 193 Gr B7
4	Body Nut	ASTM A 194 Gr 2H
60	Actuator	ROTEX-ECF-32

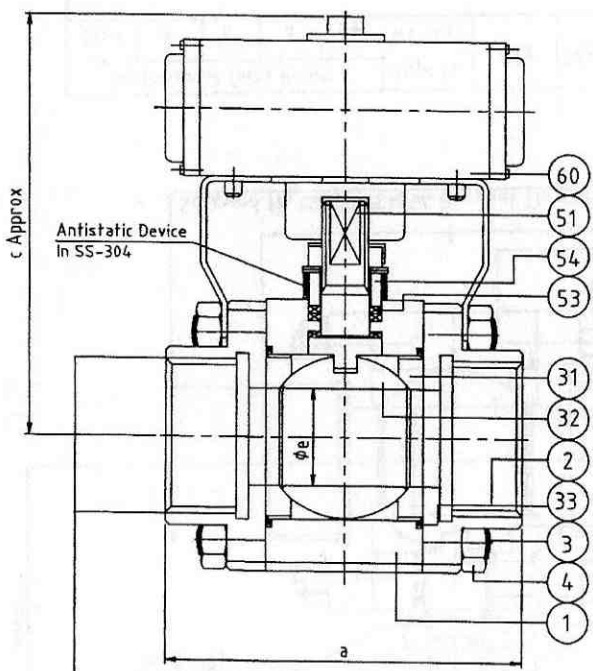

Service: Water
Design Pressure : 76 Kg/Sq.cm (g)
Operating Pressure : 3 Kg/Sq.cm (g)
Ambient Temp : 50°C. (As Per UCCI Spec) \diamond
Operating Temp : 170°C.

Actuator Details
Actuator Model : ROTEX-ECF-32
Operating Pressure : 3 Kg/Sq.cm (g)
Type : Double Acting.

NTPC DOC. NO.
2140-108-14PE-PVM-B-023
REV-01

Dimensional Data in mm				Approx. Wt, Kgs.	Qty	W.O Sno	Cust PO Sr No	Cust.Prod.Code	Data Sheet Spec.No
Size	a	c	ϕ_e						
20	70	210	13.0	2	10	3	3	70063-01-204-04	70063-01-204

CUSTOMER : UNITED CONVEYER CORPORATION (INDIA) PVT LTD
P.O No. : IN102295-5 DT : 20/11/09

Dr. No : 81020-R3-b
Our Ref. : DV-1027, 3 of 3
REV No. 11

MICRO WISH VALVES PVT. LTD.

AP
AP
CH
CH
REV-II
REV-III

DR. J.S.S. DT:12/12/09
REV-I: J.S.S. DT:27/07/10
CH-S.S.G. DT:12/12/09
CH-S.S.G. DT:27/07/10
AP-G.V.M. DT:12/12/09
AP-G.V.M. DT:27/07/10

20 NB Globe Valve Manually operated (sl. no. 2)

Certification signature by G. GUPTA
 Date: 20/01/27
 Reason: CAT
 Location: NTPCEOC

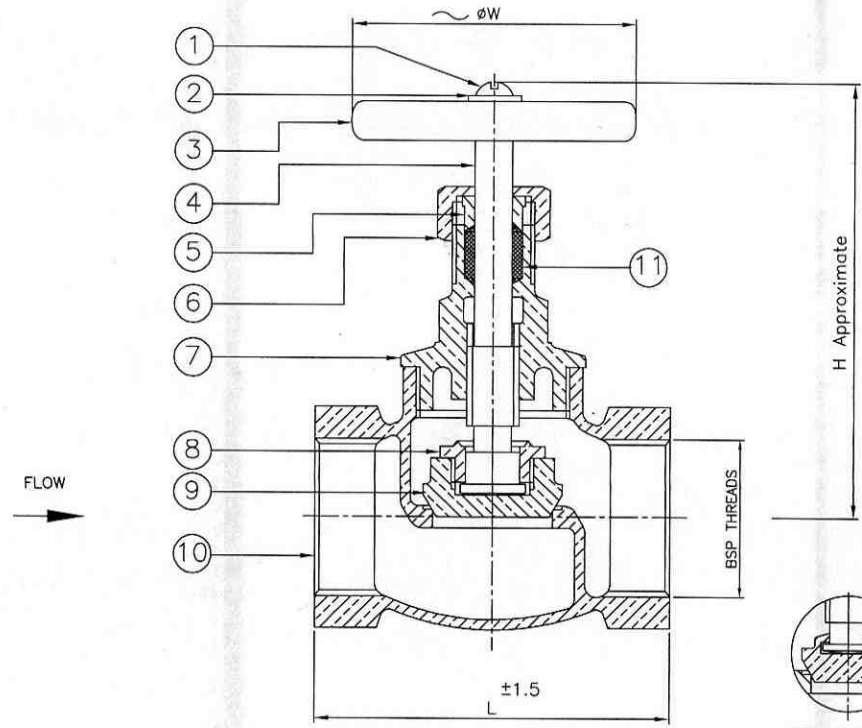

P.NO.	DESCRIPTION	NO.OFF	MATERIAL	SPECIFICATIONS
1	SCREW	1	M.S.	-
2	WASHER	1	M.S.	-
3	HANDWHEEL	1	C.I.	IS:210 Gr.FG200/-
4	STEM	1	S.S.	AISI 316
5	GLAND	1	GUN METAL	IS:318 Gr.LTB2
6	GLAND NUT	1	GUN METAL	IS:318 Gr.LTB2
7	BONNET	1	GUN METAL	IS:318 Gr.LTB2
8	DISC NUT	1	GUN METAL	IS:318 Gr.LTB2
9	VALVE DISC	1	GUN METAL	IS:318 Gr.LTB2
10	BODY	1	GUN METAL	IS:318 Gr.LTB2
11	PACKING	-	PTFE	-

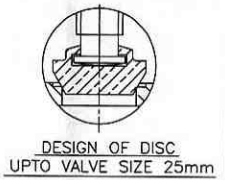

Nom.Size.	8	10	15	20	25	32	40	50	65	80	100
L	47	50	60	70	80	95	110	125	160	180	216
H	75	80	85	90	108	120	130	135	170	200	230
W	44	44	56	56	65	75	80	90	144	175	195

Nom.Size.	20	25
SERVICE	WATER	
Qty.	27 Nos.	12 Nos.
WEIGHT OF VALVE (Approx.)	0.6 Kg.	1.0 Kg.
OPERATING PRESSURE	3 Kg/cm ²	1.0 Kg/cm ²
TESTING	AS PER APPROVED QAP	
LOCATION	SERVICE WATER SUPPLY HEADER BEFORE PYRITES HOPPER	AIR RECEIVER DRAIN OUTLET

- NOTES:
 1. PAINTING AS PER NTPC APPROVED PAINTING SCHEDULE.
 2. ALL DIMENSION ARE IN MM UNLESS OTHERWISE STATED.
 3. TOLERANCE IS AS PER IS 778.
 4. MODEL NUMBER: IS9

THIS DRAWING SHALL NOT BE CONSIDERED A CERTIFIED DOCUMENT UNLESS WRITTEN APPROVAL SIGNATURES OR INITIALS ARE PRESENT.

THIS DRAWING IS AN UNPUBLISHED COPYRIGHTED WORK CONTAINING PROPRIETARY INFORMATION OF UNITED CONVEYOR CORPORATION, AND IS LOANED FOR USE IN THE CONDUCT OF COMPANY BUSINESS ONLY. THIS COPY HAS BEEN PROVIDED ON THE BASIS OF STRICT CONFIDENTIALITY AND WITH THE EXPRESS UNDERSTANDING THAT NOT BE REPRODUCED, OR REVEALED TO ANY PERSON, IN WHOLE OR IN PART, WITHOUT EXPRESS WRITTEN PERMISSION FROM UNITED CONVEYOR CORPORATION, WHICH IS THE SOLE OWNER OF COPYRIGHT AND ALL OTHER RIGHTS THEREIN. BY RECEIVING THIS DRAWING, THE RECIPIENT AGREES TO RETURN IT UPON REQUEST.

THE INSTALLATION AND OPERATION OF UNITED CONVEYOR CORPORATION EQUIPMENT, IN ACCORDANCE WITH APPROVED PLANS AND OPERATING INSTRUCTIONS, SHALL BE THE SOLE RESPONSIBILITY OF THE PURCHASER, UNLESS OTHERWISE SPECIFIED BY CONTRACT.

MODIFICATION TO UNITED CONVEYOR CORPORATION EQUIPMENT AND STRUCTURES TO AVOID FIELD OBSTRUCTIONS, OR CORRECTIONS DUE TO MINOR DRAWING DISCREPANCIES WITH FIELD CONDITIONS AND/OR MINOR FABRICATION MISFITS ARE CONSIDERED NORMAL ERECTION AND INSTALLATION OPERATIONS AND ARE NOT CHARGEABLE TO UNITED CONVEYOR CORPORATION. WE WILL NOT ACCEPT BACKCHARGES FOR ANY WORK PERFORMED IN THE FIELD UNLESS APPROVED BY OUR SERVICE GROUP (U.C. SERVICE CORPORATION) AT WAUKEGAN.

REVISION	DESCRIPTION	DATE	DSGN	CHKD	APPD (ENGR)	APPD (PRD)

SCALE	CONTRACT NUMBER	SUBSYSTEM	DRAWING SIZE
NTS	70065-01	G	A3

NTPC DRAWING NUMBER : 0330-101-14PE-PVM-B-030 REV : 0
 BHEL DRAWING NUMBER : PE-V0-285-160-A330

OWNER : NTPC Limited (A GOVERNMENT OF INDIA ENTERPRISE) ENGINEERING DIVISION

PRIME CONTRACTOR : BHARAT HEAVY ELECTRICALS LTD POWER SECTOR PROJECT ENGINEERING MANAGEMENT NEW DELHI

UNITED CONVEYOR CORPORATION (INDIA) PVT. LTD.
 11, SHAKESPEARE SARANI (5TH & 6TH FLOOR) KOLKATA-700 071, INDIA

DRAWING TITLE : GUN METAL GLOBE VALVE; SCREWED SCREWED IN BONNET, INSIDE SCREW, RISING STEM CONFORMING TO IS:778-1984 CLASS-1; ISI MARKED

SANT VALVES PVT.LTD., JALANDHAR

BODY TEST PRESSURE---1.5 MPa Hyd.
 BACK SEAT & SEAT TEST PRESSURE---1.0 MPa Hyd.
 MIN. TEST DURATION = 2 MINUTES FOR EACH TEST

PLANT NAME : INDIRA GANDHI SUPER THERMAL POWER PROJECT NTPC, JHAJJAR, INDIA 3 X 500 MW UNIT

UNITED CONVEYOR CORPORATION
 2100 NORMAN DRIVE WEST WAUKEGAN, ILLINOIS 60085

DRAWING NUMBER : F-70065-052 REVISION : A

20 NR Ball Valve Manually Operated (Ser. No. 03)

Ball Valves, Reduced Bore,
Fire Safe to API-607,
Class-800, Screwed Ends, Lever Operated. BS: EN ISO 17292

MFG.STD.

Series : 81-R3

Hydrostatic Testing (BS:EN 12266 PART-1)

Shell	210	Kg/sq.cm
Seat	78	

Pneumatic Testing (BS:EN 12266 PART-1)

Seat	7	Kg/sq.cm
------	---	----------

Part No.	Part name	Material
1	Body	ASTM A 105
2	Pipe End	ASTM A 105
32	Ball	ASTM A 276 Type 304
51	Stem (Anti Blowout)	ASTM A 276 Type 304
54	Gland	ASTM A 276 Type 304
31	Seat	PTFE
33	Body Seal	GRAFOIL
53	Stem Seal	GRAFOIL
3	Body Stud	ASTM A 193 Gr B7
4	Body Nut	ASTM A 194 Gr 2H
60	Lever	STEEL

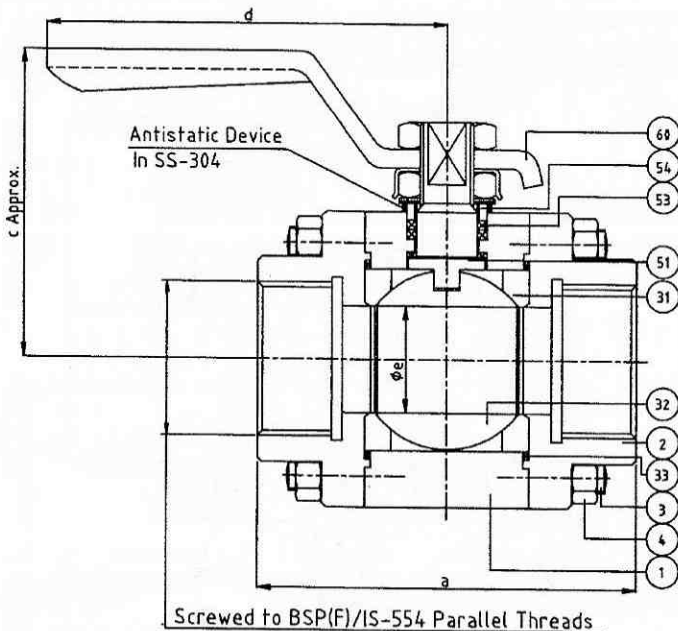

NTPC DOC. NO.
2140-108-14PE-PVM-B-023
REV-01

W.O.Sno.	Design Pr Kg/Sq.cm (g)	Operating Pr Kg/Sq.cm (g)	Ambient Temp	Operating Temp	Service
2	76	3	50°C (As Per UCCI Spec)	170°C	Water
4	76	3			Water
5	76	5.5			Pressurizing Line
6	76	7			Instrument Air Line
7	76	7			Solenoid Valve Isolation

DR: J.S.S. DT: 12/12/09
REV: J.S.S. DT: 27/01/10
CH: S.S.G. DT: 12/12/09
REV: J.S.S. DT: 27/01/10
AP: G.V.M. DT: 12/12/09
REV: J.S.S. DT: 27/01/10

Dimensional Data in mm					Approx. Wt, Kgs.	Qty	W.O.Sno.	Cust.Po.Sr.No	Cust.Prod.Code	Data Sheet Spec.No
Size	a	c	d	ϕ_e						
20	70	55	140	13.0	0.75	20	2	2	70063-01-204-03	70063-01-204
25	88	95	175	19.0	2.0	35	6	6	70063-01-204-07	
40	114	114	184	32.0	3.1	20	5	5	70063-01-204-06	

CUSTOMER : UNITED CONVEYER CORPORATION (INDIA) PVT LTD
P.O No. : IN102295-5 DT : 20/11/09

Drg. No : 81015-40-R3

Our Ref.

DV-1027, 2 of 3

MICROFISH VALVES PVT. LTD.

50 NB Butterfly Valve pneumatically operated - (Se.No. 4)
 80 NB Butterfly Valve pneumatically operated (Se.No 5)

PART LIST AND MATERIAL OF CONSTRUCTION

PT.NO.	PART NAME	MATERIAL
01	BODY	Cl - SI:210 Gr.FG260 (01)
02	DISC	DI-ASTM A536 Gr.60-40-18
03	STEM-UPPER	ASTM A276 TYPE 410
04	STEM-LOWER	ASTM A276 TYPE 410
05	SEAT	EPDM
06	O-RING	NITRILE
21	STEM BEARING	DELTRIN
22	BOTTOM CAP	ASTM A276 TYPE.410
28	RETAINER PLATE	ASTM A276 TYPE.410
38	HEX. SCREW	STEEL Gr. 8.8
42	HEX SCREW/SPRING/ WSHR	STEEL Gr. 8.8 / SPR STEEL
70	WEATHER SEAL	NITRILE
71	CSK SCREW WITH HEX.SOCKET	SS304
1A	PNEUMATIC ACTUATOR	ROTEX MAKE
1L	LIMIT SWITCH BOX	KENWOOD MAKE

DESIGN STD: EN593 (BS:5155)
 TESTING STD: EN12266-1
 (BS:6755 PART-1)
 HYDRO-TEST PRESSURE, bar

RATING	SHELL	SEAT
PN 10	15	11

B.D.K. ENGINEERING INDUSTRIES LIMITED
 BUTTERFLY VALVE MODEL - 12
 DATE : 28 JAN. 2010
 DRG. NO. 125438
 01 REV. NO

WAFER TYPE, PNEUMATIC OPERATED + LIMIT SWITCHES

SHEET NO. : 01 OF 02

- a) LIMIT SWITCH BOX KENWOOD MAKE - HONEYWELL MICROSWITCHES HOUSED IN WEATHER PROOF ENCLOSURE (IP-65), WITH 4NOS OF CONTACT (2NO+2NC), 1/2"NPT CABLE ENTRY, VOLTAGE 24V DC.
- b) ACCESSORIES MOUNTING ARRANGEMENT IS INDICATIVE ONLY, MAY VARY DURING ASSEMBLY.

NOTES :-

- 1) LAYING LENGTH 'A' CONFORMS TO EN 558 - 1 SERIES 20 (BS 5155 1984), ISO: 5752 AND MSS SP- 67 W-1(1983). OTHER DIMENSIONS AND WEIGHTS ARE INDICATIVE.
- 2) BODY & DISC DULY PU/STOVING ENAMEL COATED.
- 3) VALVES ARE SUITABLE TO SANDWICH BETWEEN ASME B16.5 CL-150 FLANGE
- 4) INTERNAL DIAMETER OF PIPE SHOULD BE AT LEAST 3mm MORE THAN 'd'
- 5) DO NOT USE PIPE LINE FLANGE GASKETES.
- 6) INSTRUMENT AIR PRESSURE FOR CYLINDER : 3 BAR. (01)
- 7) POSITIONAL INDICATOR PROVIDED. (01)
- 8) POSITION FOR : 80/50 NB CONVEYING AIR LINE NEAR DEPAC TRANSMITTER. (01)

Digitally signed by N.K. GUPTA
 DN: cn=N.K. GUPTA, c=IN,
 o=NTPCLTD, ou=TASKFORCE,
 email=nkgupta@ntpceoc.co.in
 Reason: CAT-1
 Date: 2010.02.01 17:22:44 +05'30'

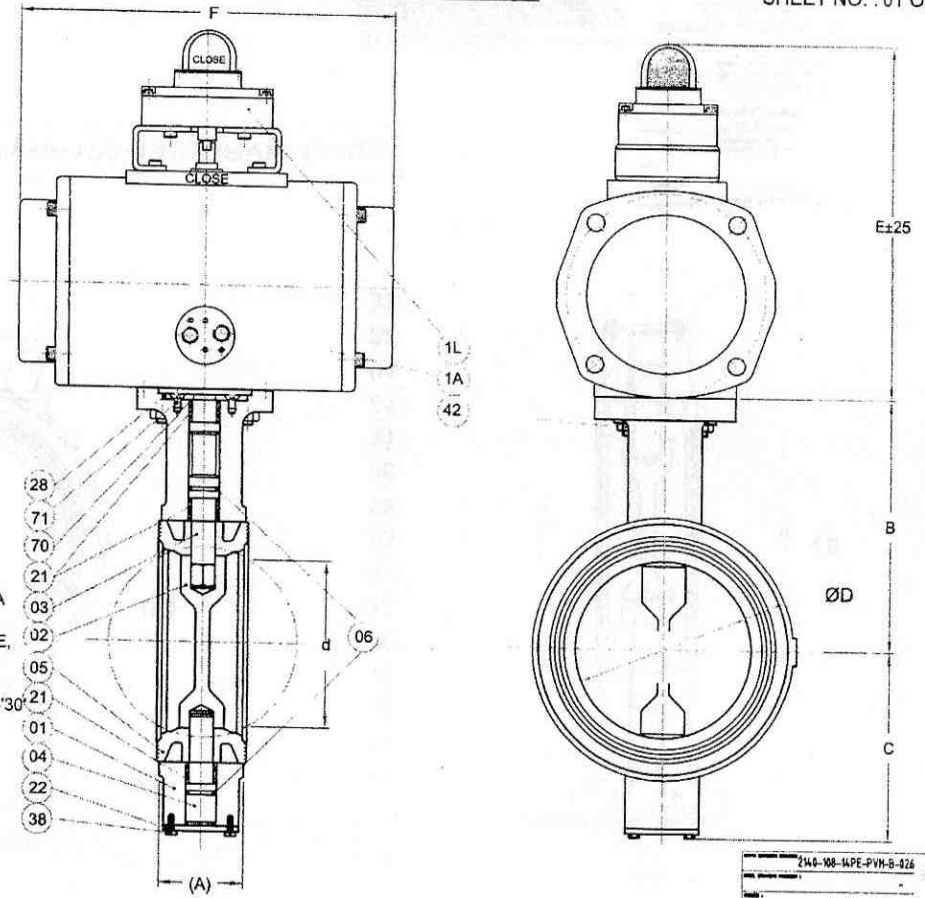

ALL DIMENSIONS ARE IN mm.

VALVE SIZE	A	B	C	ØD	d	E	F	ACTUATOR MODEL	WEIGHT-Kg (approx)	QTY	TAG NO.
50	43	115	75	52	33.5	220	141	ECF-40	5.5	10	70064-01-203-02
80	48	135	90	78	66	235	197	ECF-63	7.5	10	70064-01-203-01

2140-108-14PE-PVM-B-026

CUSTOMER: M/s, UNITED CONVEYOR CORPORATION INDIA PVT. LIMITED.
 ENQUIRY NO. IN102293-5. DT : 17/12/2009. (W.O.NO. : B0466E - 2009).
 JOB PROJECT: _____
 MANUFACTURED BY : M/s B.D.K. ENGINEERING INDUSTRIES LIMITED, HUBLI - 580 030, INDIA.

2140-108-14PE-PVM-B-026 01

UNITED CONVEYOR CORPORATION (INDIA) PVT. LTD.
 BANGALORE
 BUTTERFLY VALVE MODEL - 12
 WAFER TYPE, PNEUMATIC OPERATED
 UNITED CONVEYOR CORPORATION
 F-70063-DXX

PT.NO.	PART NAME	MATERIAL
01	BODY	CI - SI:210 Gr.FG260 (01)
02	DISC	DI-ASTM A536 Gr.60-40-18
03	STEM-UPPER	ASTM A276 TYPE 410
04	STEM-LOWER	ASTM A276 TYPE 410
05	SEAT	EPDM
06	O - RING	NITRILE
11	THROTTLING PLATE	MS-IS:2062
13	BOLT/ NUT/ LK.WSHR	STEEL Gr. 8.8/8/STEEL
17	HANDLE UNIT	CS
21	STEM BEARING	DELRIN
22	BOTTOM CAP	ASTM A276 TYPE 410
28	RETAINER PLATE	ASTM A276 TYPE 410
38	HEX. SCREW	STEEL Gr. 8.8
70	WEATHER SEAL	NITRILE
71	CSK SCREW WITH HEX SOCKET	SS 304

DESIGN STD: EN593 (BS:5155)
 TESTING STD: EN12266-1
 (BS:6755 PART-1)

HYDRO-TEST PRESSURE, bar

RATING	SHELL	SEAT
PN 10	15	11

B.D.K. ENGINEERING INDUSTRIES LIMITED



BUTTERFLY VALVE, MODEL - 12

DATE: 28 JAN. 2010

DRG.NO: 125439

01
REV.NO.

SHEET NO. : 02 OF 02

ALL DIMENSIONS ARE IN mm.

SIZE	100
A	52
B	153
C	118
ØD	103
d	91.5
E	35
F	265
Wt-kg	7.0
QTY	06

TAG NO. 70064-01-203-03

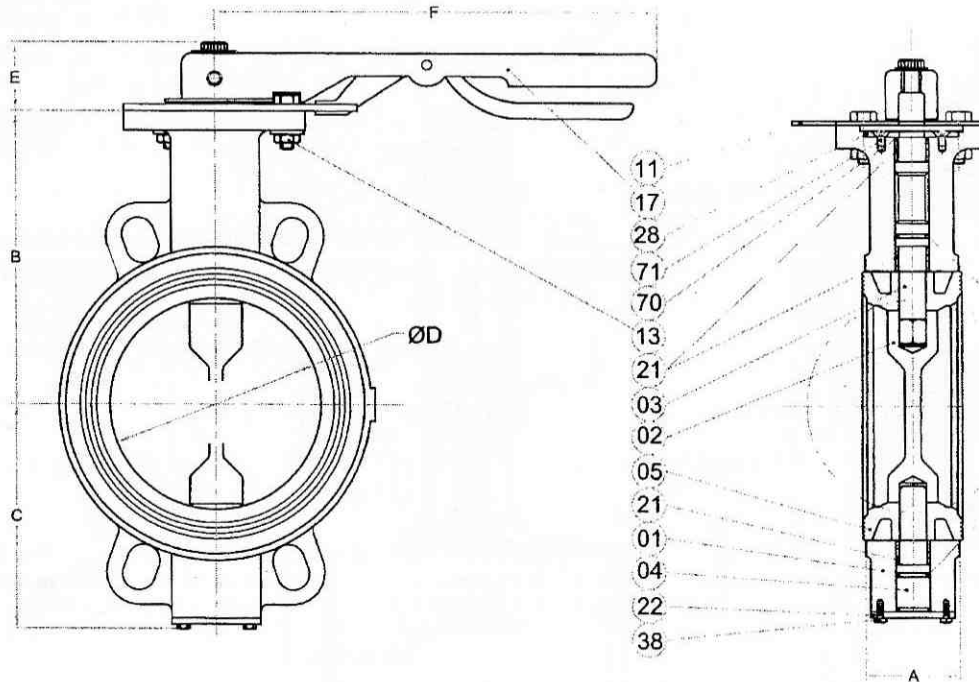

NOTES :

- LAYING LENGTH 'A' CONFORMS TO EN 558 - 1SERIES 20 (BS 5155 1984), ISO: 5752 AND MSS SP- 67 W-1(1983). OTHER DIMENSIONS AND WEIGHTS ARE INDICATIVE.
- BODY, HANDLE UNIT & DISC DULY PU/STOVING ENAMEL COATED.
- VALVES ARE SUITABLE TO SANDWICH BETWEEN ASME B16.5 CL-150, FLANGES.
- INTERNAL DIAMETER OF PIPE SHOULD BE AT LEAST 3 mm MORE THAN 'd'.
- DO NOT USE PIPE LINE FLANGE GASKETES.
- LOCATION FOR 100 NB TRANSPORT AIR ISOLATION VALVE NEAR COMPRESSOR. (01)

2140-108-14PE-PVM-B-026

CUSTOMER. M/s. UNITED CONVEYOR CORPORATION INDIA PVT. LIMITED.
 ENQUIRY NO. IN102293-5. DT: 17/12/2009. (W.O.NO. : B0466E - 2009).
 JOB PROJECT. _____

MANUFACTURED BY : M/s B.D.K. ENGINEERING INDUSTRIES LIMITED, HUBLI - 580 030, INDIA.

2140-108-14PE-PVM-B-026

UNITED CONVEYOR CORPORATION (INDIA) PVT. LTD.
 8, BANGALORE ROAD, 1ST STAGE, HALASARU, BANGALORE, INDIA

BUTTERFLY VALVE MODEL - 12
LEVER OPERATED.

UNITED CONVEYOR CORPORATION
 8, BANGALORE ROAD, 1ST STAGE, HALASARU, BANGALORE, INDIA

F-70063-0XX

THIS DRAWING SHALL BE THE PROPERTY OF B.D.K. ENGINEERING INDUSTRIES LIMITED. IT IS TO BE KEPT IN STRICT CONFIDENCE AND NOT TO BE REPRODUCED OR COPIED IN ANY MANNER WITHOUT THE WRITTEN PERMISSION OF B.D.K. ENGINEERING INDUSTRIES LIMITED. THE DRAWING IS AN UNCONTROLLED COPY. THE USER SHALL BE RESPONSIBLE FOR THE ACCURACY OF THE INFORMATION AND DATA CONTAINED THEREIN. THE USER SHALL BE RESPONSIBLE FOR THE ACCURACY OF THE INFORMATION AND DATA CONTAINED THEREIN. THE USER SHALL BE RESPONSIBLE FOR THE ACCURACY OF THE INFORMATION AND DATA CONTAINED THEREIN. THE USER SHALL BE RESPONSIBLE FOR THE ACCURACY OF THE INFORMATION AND DATA CONTAINED THEREIN.

Direct Drawing of 40NB Flow Control Valve (Sl. No. 6)

FLOW DIRECTION: FLOW TO OPEN
 ACTUATOR: TOP MOUNTED HANDWHEEL
 NTPC Doc. No. 2140-108-14PE-PVI-B-016-01
 Project: KORBA-III MRS
 Rev-01
 G A of Manual Flow Control Valve

MIL Controls Limited
 MODEL NO: 20T-21125

N.K. Gupta

Digitally signed by N.K. GUPTA
 DN: cn=N.K. GUPTA, c=US,
 o=NTPC LTD, ou=NTPC LTD,
 email=nkgupta@ntpceoc.co.in
 Reason: CAT-1
 Date: 2010.07.16 10:26:08
 +05'30'

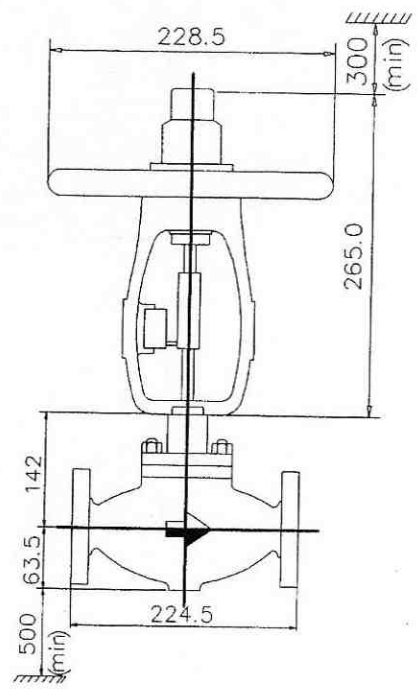

NOTE:

1. All dimensions are in mm unless otherwise specified.
2. End to end dimension tolerance: ± 1.5 mm.
3. Accessories shown in diagram are for dimensional reference only.
4. Accessories indicated in approved data sheets shall only be mounted on valves.
5. Position of accessories mounted on the valve may be modified to minimize tubing length.
6. Overall height is indicative only and may vary as follows
 Size upto 4" - 50mm, 6" to 10" - 80mm, 12" & above - 120mm.

VALVE DETAILS

Total Approximate Weight = 40Kg
 CHARACTERISTIC : EQUAL-PERCENTAGE
 STANDARD , THREADED SEAT
 BONNET : STANDARD

PROJECT	NTPC, KORBA STPP-III			S.O. No.	L0466	DWG NO:	L0466001
CUSTOMER	UNITED CONVEYOR CORP PVT LTD CALCUTTA			Valve size	1.50"	Act. Size	Type 20
Cust. Ref.	E MAIL DTD 08.01.2010			Rating	150#	Face Serration	SPIRAL
Item No.	001	Qty.	20	End Conn.	150 FF (ASME B 16.5) Δ		
Tag No.	70063-01-226			Revision	1	Date	17/05/2010
Prepared	GA						

R1
R1

Date: 20/11/2010 11:00 IST
 Reason: CAT IV
 Location: NTPCEOC

65 NR Check Valve (Se. No. 7)

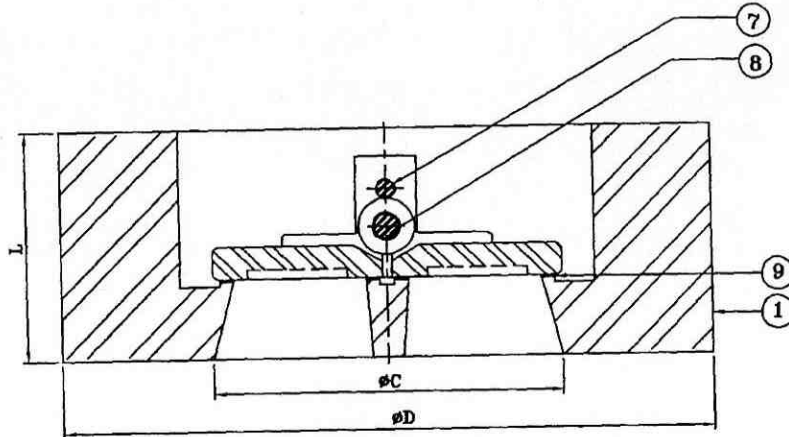
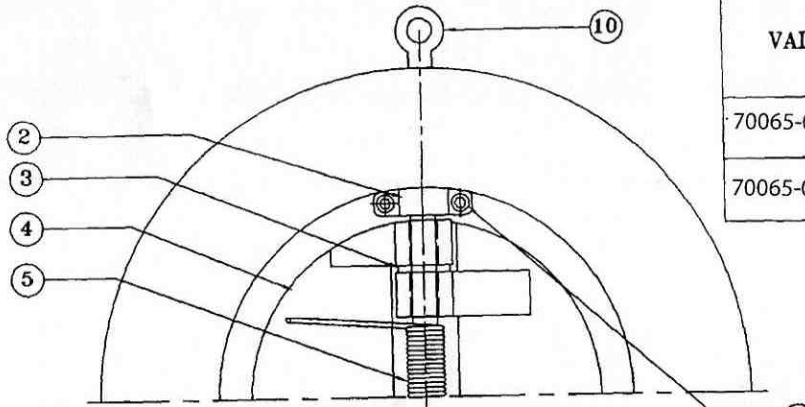

NOTE: 1) PAINTING SHALL BE AS PER NTPC PAINTING SCHEDULE.
 2) TESTING AS PER NTPC APPROVED QAP.

VALVE PART NO.	VALVE SIZE	DIMENSIONAL DATA			QTY.
		± 1.6 L	ØC	ØD	
70065-01-205-02	40mm	60	40	80	54
70065-01-205-03	65mm	67	65	119	27

INDIRA GANDHI STPP, 3 x 500 MW, Jhajjar, Units 1, 2 & 3
 GENERAL ARRANGEMENT OF AIRLINE CHECK VALVE
 NTPC DOC NO.: 0330-101-14PE-PVM-B-029_00
 BHEL DOC NO.: PE-V0-285-160-A329
 UCCI DOC NO.: F-70065-01-045

STANDARD MATERIAL COMBINATION				
P.No	Name of Part	No.Off	Material	Specification/Standard
10	EYE BOLT	1	C.S.	ANY GRADE
9	SEAT	1	EPDM	
8	DISC HOLDER PIN	1	S.S.	TYPE 316
7	STOPPER PIN	1	S.S.	TYPE 316
6	L-KEY SCREW	4	S.S.	TYPE 316
5	SPRING	1	S.S.	TYPE 316
4	DISC	2	C.I.	IS 210:93 Gr.25 WITH 0.30 MAX.P.
3	BUSH	TO SUIT	S.S.	TYPE 304
2	DISC HOLDING PLATE	2	C.C.S.	ASTM A216:07 Gr. WCB
1	BODY	1	C.I.	IS 210:93 Gr.25 WITH 0.30 MAX.P.

PART No.	REVISION MADE	REVISION No.	DATE	AUTHORISED SIGNATORY	REMARKS
	COMMENTS INCORPORATE	01	20/11/2010	G.D.SAHNI	REVISED BY NAND
	COMMENTS INCORPORATE	02	06/12/2010	<i>[Signature]</i>	REVISED BY NAND

LEADER VALVES LTD.
 JALANDHAR-144004(INDIA)

All Dimensions in mm

C.I. DUAL PLATE WAFER TYPE CHECK VALVE
 INSERTION BETWEEN FLANGES AS PER ANSI B16.1 CL-125
PRODUCT SPECIFICATION: API 594:04

SCALE N.T.S.

TEST PRESSURE:-
 BODY :- 20.7 Bar. (Hyd.)
 SEAT :- 15.18 Bar. (Hyd.)

TESTING STANDARD : 598:04

DRN.	SUNIL	21.09.10
CHKD.	G.D.SAHNI	22.09.10
APPRD.	G.D.SAHNI	22.09.10

DRG.No.
028 WIK-1000D/G/CM

Issue Status 02
 SHEET 1 OF 1

Indfos Industries Limited

Data sheet for Temperature switch (Sl. No. 12)
NTPC DOC NO: - 2140-108-14PE-PVI-Y-003, REV-00
BHEL DOC NO:- PE-V0-249-160-A409
UCCI DOC NO:- F-70063-01-021
LOCATION: NEAR DEPAC PYRITES TRANSMITTER



Customer: Machine Tools Centre
MTC PO No. 5652 Dt. 19.11.2009 A/c. UCCIL (NTPC, Korba)
DATA SHEET FOR TEMPERATURE SWITCHES

Model : T4 64 T35030 XFS XPC X69C XTW
Range : 70-170 Deg. C
Settings : Adjustable through out the range span, internally.
Set Point : 120 ° C (Please specify Rising/Falling)
Sensing : Vapour filled thermal system
Enclosure : Die cast Aluminium epoxy coated weather proof to IP: 66 of IS: 13947
Contact : 2 SPDT (2NO+2NC), Snap action shock & Vibration proof Micro Switch
Contact Rating : 15 A 250 V AC/6A 30 V DC
Max. Temperature : 260 ° C
Contact Differential : Fixed, 10.6 ° C
Electrical Connection : 7 Pin Plug in Connector
Process Connection : ½" NPT (M)
Capillary Matl. : 316 SS with 304 SS armour
Capillary Length : 10 Metre
Bulb Length : 76 mm
Bulb dia & material : 9.5 mm & SS 316
Repeatability : (+) / (-) 1% of FS
Accuracy : (+) / (-) 1% of FS
Thermowell : ½" NPT (M), 200 mm immersion length
Material : 316 SS Barstock
Quantity : 10 Nos.

N.K. Gupta

Digitally signed by N. K. GUPTA
DN: cn=N. K. GUPTA, c=IN,
o=NTPC, ou=NTPC-CC,
email=nkgupta@ntpceoc.co.in
Reason: CAT-I
Date: 2010.02.25 18:10:35
+05'30'

INDFOS INDUSTRIES LTD.



Drawing of Solenoid Valve (Sp. No. 15)

NOTE- ALL DIMENSIONS ARE IN mm

CUSTOMER - NTPC INDIA.
 PROJECT- NTPC KORBA STPP, KORBA, STAGE-III, UNIT-7
 P.O.No.- IN102311-3 Dtd: 02/12/2009

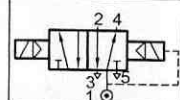

Digitally signed by N. K. GUPTA
 DN: cn=N. K. GUPTA, c=IN, o=NTPC, ou=NTPC-CC, email=nkgupta@ntpcoc.co.in
 Reason: CAT-I
 Date: 2010.03.04 16:25:10 +05'30'

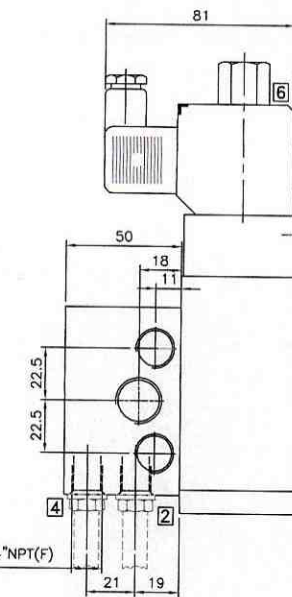
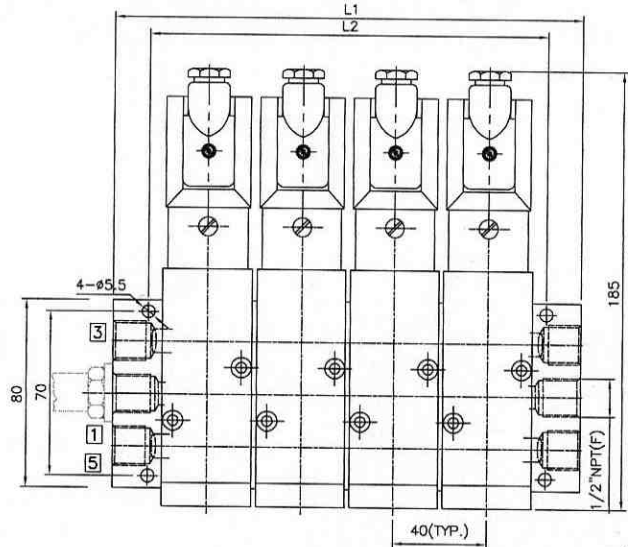
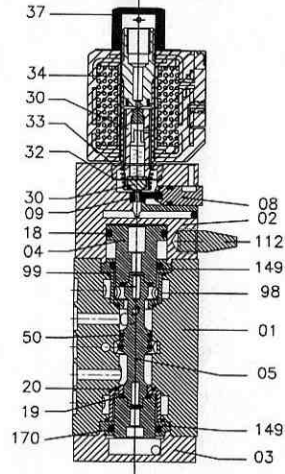

MANUAL OVERRIDE
 PUSH TO OPERATE,
 PUSH&TURN CLOCKWISE TO LOCK.

- SERVICE:
- 1) IA LINE TO 200 NB KGV AT BOWL MILL ISOLATION VALVE.
 - 2) 80 NB B/F VALVE AT CONVEYING AIR LINE.
 - 3) 50 NB B/F VALVE AT PRESSURIZING AIR LINE.
 - 4) 20 NB BALL VALVE AT SERVICE WATER LINE TO PYRITES HOPPER

NTPC DOC. NO. 2140-108-14PE-PVM-Y-004 , REV-01
 BHEL DOC. NO. PE-VO-249-160-A111
 UCCI DOC. NO. F-70063-01-018
 SHEET- 1 OF 2
 GA of solenoid valve

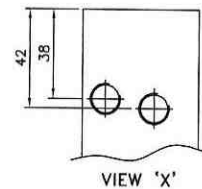

GA OF SOLENOID VALVE

VALVE SPECIFICATION

- 01) VALVE TYPE - 5/2 INTERNAL PILOT OPERATED, POPPET TYPE SUB BASE MOUNTED, SINGLE SOLENOID VALVE
- 02) MODEL - 51445A-6-SB+24V-DC-22
- 03) MEDIA - AIR
- 04) SEAT/SEAL - NBR
- 05) WORKING PRESSURE - 2-10 bar
- 06) ORIFICE - 6mm
- 07) FLOW FACTOR (kv) - 12 lpm
- 08) MANIFOLD CONNECTION - 1/2" NPT(F) (INLET)
- 09) MANIFOLD CONNECTION - 1/4" NPT(F) (OUTLET)
- 10) BODY MATERIAL - ALUMINIUM
- 11) COIL CODE - 22
- 12) COIL VOLTAGE - 24V DC
- 13) COIL INSULATION - CLASS F
- 14) COIL POWER - 8 Watt
- 15) COIL TYPE - PLUG IN TYPE
- 16) DEGREE PROTECTION - IP67
- 17) PART NO. - 70063-01-210-1
- 18) QTY; 10 NOS.

CONNECTION

- 1 INLET
- 2 OUTLET
- 3 EXHAUST
- 4 OUTLET
- 5 EXHAUST
- 6 PILOT VENT

10	10	440	410	
09	09	400	370	
08	08	360	330	
07	07	320	290	
06	06	280	250	
05	05	240	210	
04	04	200	170	
03	03	160	130	
02	02	120	90	
01	01	80	50	
Sr. No.	No. OF VALVES PER MANIFOLD	L1	L2	REMARKS

QTY.	DESCRIPTION	Sr.No.	POS.No.	MATERIAL	REMARKS
02	BUSH 'O' RING	21	170	NBR	
02	BUSH	20	149	BRASS	
01	MUFFLER	19	112	BRONZE	
02	SLEEVE 'O' RING	18	99	NBR	
02	SLEEVE	17	98	BRASS	
02	VENTIL SHAFT 'O' RING	16	50	NBR	
01	DOME NUT	15	37	PLASTIC	
01	COIL ASSLY.	14	34	-	
01	GUIDE ASSLY.	13	33	SS	
02	GUIDE 'O' RING	12	32	NBR	
01	PLUNGER ASSLY.	11	30	SS430+SS304	
02	BODY 'O' RING	10	20	NBR	
02	SEAT 'O' RING	09	19	NBR	
02	PISTON 'O' RING	08	18	NBR	
01	DUSE	07	09	SS316	
01	M.A.	06	08	SS	
01	VENTILSCHAF (VALVE SHAFT)	05	05	BRASS	
02	PISTON	04	04	BRASS	
01	BODEN	03	03	BRASS	
01	DECKEL (COVER)	02	02	BRASS	
01	GEHAUSE (BODY)	01	01	BRASS	

GA DRAWING OF 51445A-6

DRN.	PHP	17.12.2009			W.O.No.	SCALE - 1 : 1
APPD.					1Q7116	

DRG.No. 082-04-231-199-1
 ROTEX AUTOMATION LIMITED
 987/11, GIDC, MAKARPURA, VADODARA-10.
 1 OF 1
 24.12.2009

n.t.m.±3

CAD. REF. -

Drawing of Level Probe (S.No. 14)

CM 0 1 2 3 4 5
IN 0 1/2 1 2 3

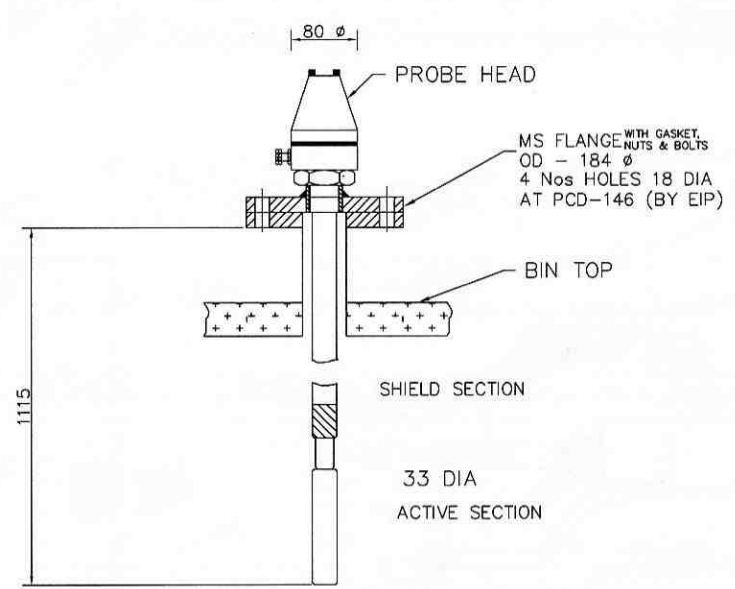

SENSING PROBE

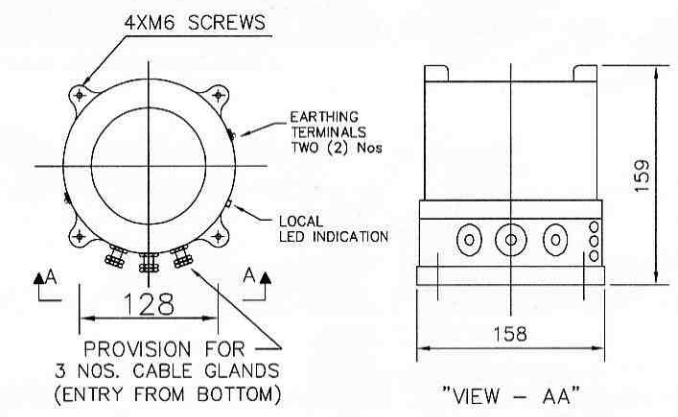

ELECTRONIC CONTROLLER

- NOTES:-
1. ALL DIMENSIONS ARE IN MM $\pm 5\%$
 2. DEGREE OF PROTECTION FOR PROBE HEAD & ELECTRONIC CONTROLLER ENCLOSURE AS PER IP-66
 3. SHIELD SECTION OF THE SENSING PROBE MUST PROJECT INSIDE THE HOPPER MORE THAN 25 MM (1")
 4. INSULATION - PTFE UPTO 200 DEG. C.
 5. QTY. - 1 NO
 6. LOCATION - PYRITES STORAGE BIN
 7. ESTIMATED WEIGHT - 10KG.

R1
R1

THIS DRAWING SHALL NOT BE CONSIDERED A CERTIFIED DOCUMENT UNLESS WRITTEN APPROVAL SIGNATURES OR INITIALS ARE PRESENT.

THIS DRAWING IS AN UNPUBLISHED COPYRIGHTED WORK CONTAINING PROPRIETARY INFORMATION OF UNITED CONVEYOR CORPORATION, AND IS LOANED FOR USE IN THE CONDUCT OF COMPANY BUSINESS ONLY. THIS COPY HAS BEEN PROVIDED ON THE BASIS OF STRICT CONFIDENTIALITY AND WITH THE EXPRESS UNDERSTANDING THAT EXCEPT IN THE CONDUCT OF UNITED CONVEYOR CORPORATION BUSINESS, IT MAY NOT BE REPRODUCED, OR REVEALED TO ANY PERSON, IN WHOLE OR IN PART, WITHOUT EXPRESS WRITTEN PERMISSION FROM UNITED CONVEYOR CORPORATION, WHICH IS THE SOLE OWNER OF COPYRIGHT AND ALL OTHER RIGHTS THEREIN. BY RECEIVING THIS DRAWING, THE RECIPIENT AGREES TO RETURN IT UPON REQUEST.

THE INSTALLATION AND OPERATION OF UNITED CONVEYOR CORPORATION EQUIPMENT, IN ACCORDANCE WITH APPROVED PLANS AND OPERATING INSTRUCTIONS, SHALL BE THE SOLE RESPONSIBILITY OF THE PURCHASER, UNLESS OTHERWISE SPECIFIED BY CONTRACT.

MODIFICATION TO UNITED CONVEYOR CORPORATION EQUIPMENT AND STRUCTURES TO AVOID FIELD OBTUSIONS, OR CORRECTIONS DUE TO MINOR DRAWING DISCREPANCIES WITH FIELD CONDITIONS AND/OR MINOR FABRICATION DEFECTS ARE CONSIDERED NORMAL DIRECTION AND INSTALLATION OPERATIONS AND ARE NOT CHARGEABLE TO UNITED CONVEYOR CORPORATION. HE WILL NOT ACCEPT BACKCHARGES FOR ANY WORK PERFORMED IN THE FIELD UNLESS APPROVED BY OUR SERVICE GROUP (I.E. SERVICE CORPORATION) AT WALKERGAN.

REVISION	DESCRIPTION	DATE	DSGN	CHKD	APPR (ENGR)	APPR (PROJ)

NTPC DRAWING NUMBER : 2140-105-14PE-PV-B-013	REV : 1
DEVL DRAWING NUMBER : PE-VO-246-160-A313	
UCCO DRAWING NUMBER : F-70063-01-034	
OWNER : NTPC Limited (A DIVISION OF IHD ENGINEERING) ENGINEERING DIVISION	
PRINCIPAL CONTRACTOR : BHARAT HEAVY ELECTRICALS LTD POWER SECTOR PROJECT ENGINEERING MANAGEMENT NEW DELHI	
UNITED CONVEYOR CORPORATION (INDIA) PVT. LTD. 11, SHAKESPEARE SARANI (5TH & 6TH FLOOR) KOLKATA-700 071, INDIA	
DRAWING TITLE GA & DIMENSION RF LEVEL PROBE MODEL-550	
MANUFACTURER NAME EIP ENVIRO LEVEL CONTROLS NOIDA-INDIA	
UNITED CONVEYOR CORPORATION 2100 NORMAN DRIVE WEST WALKERGAN, ILLINOIS 60085	
DRAWING NUMBER	REVISION
UCCI-KRB-01	0
SH 2 OF 3	

DWGLOCATION

CM 0 .5 1 2 3 4 5

Drawing of Level Probe (Sl. No. 14)

CM 0 1 2 3 4 5
IN 0 1/2 1 2 3

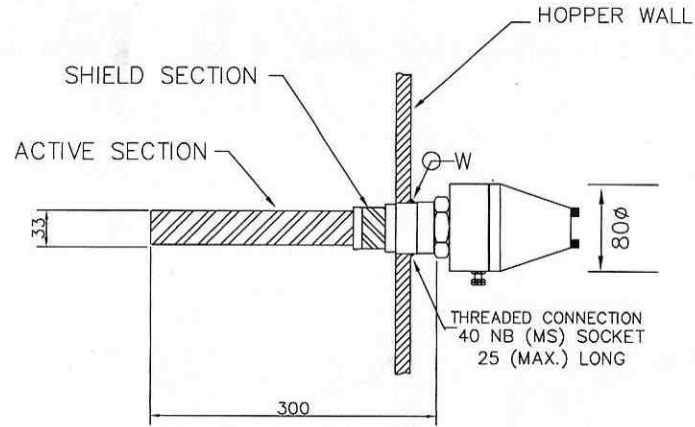

SENSING PROBE
(RIGID)

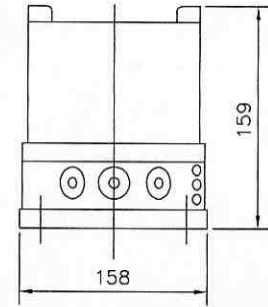
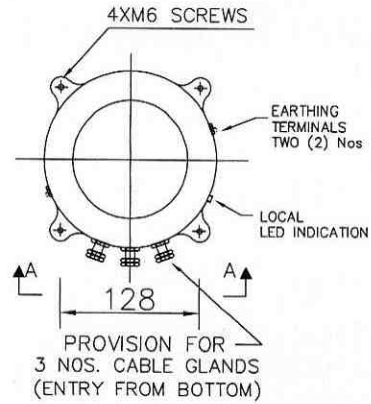

"VIEW - AA"

Digitally signed by N.K. GUPTA
DN: cn=N.K. GUPTA, c=IN, o=NTPCLTD, ou=TASKFORCE, email=nkgupta@ntpce oc.co.in
Reason: CAT-I
Date: 2010.02.24 17:17:28 +05'30'

ELECTRONIC CONTROLLER

NOTES: -

1. ALL DIMENSIONS ARE IN MM $\pm 5\%$
2. DEGREE OF PROTECTION FOR PROBE HEAD & ELECTRONIC CONTROLLER ENCLOSURE AS PER IP-66
3. SHIELD SECTION OF THE SENSING PROBE MUST PROJECT INSIDE THE HOPPER MORE THAN 25 MM (1")
4. INSULATION - PTFE UPTO 200 DEG. C.
5. QTY. -20 NOS.
6. LOCATION-PYRITES HOPPER.
7. ESTIMATED WEIGHT-10KG.

N.K. Gupta

DWLOCATION

REVISION	DESCRIPTION	DATE	DSGN	CHKD	APPD (ENGR)	APPD (PROJ)

THIS DRAWING SHALL NOT BE CONSIDERED A CERTIFIED DOCUMENT UNLESS WRITTEN APPROVAL SIGNATURES OR INITIALS ARE PRESENT.

THIS DRAWING IS AN UNPUBLISHED COPYRIGHTED WORK CONTAINING PROPRIETARY INFORMATION OF UNITED CONVEYOR CORPORATION, AND IS LOANED FOR USE IN THE CONDUCT OF COMPANY BUSINESS ONLY. THIS COPY HAS BEEN PROVIDED ON THE BASIS OF STRICT CONFIDENTIALITY AND WITH THE EXPRESS UNDERSTANDING THAT IT MAY NOT BE REPRODUCED, OR REVEALED TO ANY PERSON, IN WHOLE OR IN PART, WITHOUT EXPRESS WRITTEN PERMISSION FROM UNITED CONVEYOR CORPORATION, WHICH IS THE SOLE OWNER OF COPYRIGHT AND ALL OTHER RIGHTS THEREIN. BY RECEIVING THIS DRAWING, THE RECIPIENT AGREES TO RETURN IT UPON REQUEST.

THE INSTALLATION AND OPERATION OF UNITED CONVEYOR CORPORATION EQUIPMENT, IN ACCORDANCE WITH APPROVED PLANS AND OPERATING INSTRUCTIONS, SHALL BE THE SOLE RESPONSIBILITY OF THE PURCHASER, UNLESS OTHERWISE SPECIFIED BY CONTRACT.

MODIFICATION TO UNITED CONVEYOR CORPORATION EQUIPMENT AND STRUCTURES TO AVOID FIELD OBSTRUCTIONS, OR CORRECTIONS DUE TO MINOR DRAWING DISCREPANCIES WITH FIELD CONDITIONS AND/OR MINOR FABRICATION MISSETS ARE CONSIDERED NORMAL ERECTION AND INSTALLATION OPERATIONS AND ARE NOT CHARGEABLE TO UNITED CONVEYOR CORPORATION. WE WILL NOT ACCEPT BACKCHARGES FOR ANY WORK PERFORMED IN THE FIELD UNLESS APPROVED BY OUR SERVICE GROUP (U.C. SERVICE CORPORATION) AT WALKERGAN.

SCALE	CONTRACT NUMBER	SUBSYSTEM	DRAWING SIZE
DWSCALE	CONTRACTNO	SUBSYSTEM	DWGID

NTPC DRAWING NUMBER: 2140-108-14PE-Pyri-B-013	REV: 1
ENCL DRAWING NUMBER: PE-WD-249-150-A313	1
UCC DRAWING NUMBER: F-70063-01-034	
OWNER: NTPC Limited (A GOVERNMENT OF INDIA ENTERPRISE) ENGINEERING DIVISION	
PROJECT CONTRACTOR: BHARAT HEAVY ELECTRICALS LTD POWER ROOM PROJECT ENGINEERING MANAGEMENT NEW DELHI	
UNITED CONVEYOR CORPORATION (INDIA) PVT. LTD. 11, SHAKESPEARE SARANI (5TH & 6TH FLOOR) KOLKATA-700 071, INDIA	
DRAWING TITLE: GA & DIMENSION RF LEVEL PROBE MODEL-550	
MANUFACTURER NAME: EIP ENVIRO LEVEL CONTROLS NOIDA-INDIA	
UNITED CONVEYOR CORPORATION 2100 NORMAN DRIVE, WEST WALKERGAN, ILLINOIS 60085	
DRAWING NUMBER: UCC-KRB-01 SH 1 OF 3	REVISION: 0

CM 0 .5 1 2 3 4 5

IN 0 1/2 1 2 3

SPECIAL CONDITIONS OF CONTRACT (SCC)**IMPORTANT NOTES:**

This is an E-tender floated online through our E-Procurement Site <https://bheleps.buyjunction.in>. The bidder should respond by submitting their offer online only in our e-Procurement platform at <https://bheleps.buyjunction.in>. Offers are invited in two-parts only. No Hard copy bid or bids through email/ fax shall be accepted. Bids are invited in two parts & shall be submitted as described below:

OFFER DESCRIPTION	DOCUMENTS TO BE UPLOADED & MODALITY OF UPLOADING DOCUMENTS
TECHNICAL OFFER	<ol style="list-style-type: none"> 1. Scanned copy of Covering letter of offer (To be attached in Attachment section) 2. Scanned copy of Entire tender documents signed & stamped in each page by authorized representative of the bidder except price bid (To be attached in Attachment section). 3. Scanned copy of Techno-Commercial Offer (To be attached in Attachment section) 4. Duly filled all annexures except price & unpriced format (To be attached in Attachment section). 5. All supporting documents/ Annexures etc., as applicable (To be attached in Attachment section). 6. No deviation certificate in bidders letterhead as per format given in GCC (To be attached in Attachment section).
PRICE BID	<ol style="list-style-type: none"> 7. Duly filled in Price Schedule as per Tender. (To be attached in price bid Attachment section) <p><i>Any other document uploaded in the price bid, as per tender format, shall not be taken into cognizance for evaluation of offer.</i></p>

1. SCOPE OF WORK:

Procurement of items for Mill Reject System as per Item Descriptions and related Drawings (Part-B) for BHEL-SITE OFFICE, INDIRA GANDHI SUPER THERMAL POWER PROJECT, P.O. –JHARLI, DISTT. - JHAJJAR, HARYANA – 124141 on F.O.R. Destination Basis. Unloading of materials at Destination/Site shall be in the BHEL’s scope.

2. PRICE BASIS:

Price in INR should be quoted for F.O.R destination delivery at CONSTRUCTION MANAGER, BHEL-SITE OFFICE, INDIRA GANDHI SUPER THERMAL POWER PROJECT, P.O. –JHARLI, DISTT. - JHAJJAR, HARYANA – 124141.

3. EVALUATION CRITERIA:

Tender will be evaluated based On TOTAL ORDER VALUE F.O.R BASIS (SL.NO.7) OF PRICE SCHEDULE (PART – “E”) of Tender.

4. TAXES AND DUTIES:

4A) Price quoted should be inclusive of all the applicable charges, Taxes and Duties. However rates of Sales Tax, Excise Duty & other statutory levies should be indicated separately if applicable. Variation in Excise Duty, Sales Tax/ Vat or any other statutory levies during contractual delivery period shall be to BHEL’s account. **BHEL shall not issue ROAD PERMITS, as road permit is not applicable for Haryana.** Any other govt. levies as per actuals shall be reimbursed by BHEL on submission of relevant documentary proof by supplier. **BHEL SHALL NOT ISSUE ‘C’ FORM.**

4B) Excise duty incurred by seller/contractor on items against the dispatch constituting a sale under the order alone shall be reimbursed at actuals against requisite documentary evidence. The invoice cum excise duty gate pass (excise invoice) should contain the name of ultimate consignee as specified in the order.

QUOTED RATES SHALL REMAIN FIRM EXCEPT FOR VARIATION IN DUTIES / TAXES AS MENTIONED AT SERIAL NO. 4. A) ABOVE.

5. INSPECTION: NOT REQUIRED.
6. DELIVERY: DELIVERY OF THE MATERIAL SHALL BE WITHIN 01 MONTH FROM THE DATE OF PO.
7. TRANSIT INSURANCE: TRANSIT INSURANCE OF MATERIAL IS IN SUPPLIER'S SCOPE.
8. VALIDITY OF OFFER: Offer should be valid for a period of 60 Days from the date of Techno-commercial Bid (Part-I) opening.
9. PAYMENT TERMS: 9.1). 90% PAYMENT + 100% TAXES AND DUTIES, P & F, FREIGHT & INSURANCE AGAINST RECEIPT, MATERIAL VERIFICATION, AND ACCEPTANCE OF ALL MATERIALS AT SITE STORES AS PER THE COMPLETE SCOPE OF SUPPLY 9.2). BALANCE 10% AFTER 60 DAYS OF RECEIPT OF MATERIAL.
10. BILLING DOCUMENTS: THE SET OF DOCUMENTS REQUIRED FOR PAYMENT SHALL BE AS FOLLOWS: <ol style="list-style-type: none"> 1. Original Tax Invoices 2. Copy of LR/GR. 3. Packing List.
11. PERFORMANCE BANK GUARANTEE & EMD: NOT APPLICABLE.
12. PAYING AUTHORITY: CONSTRUCTION MANAGER, BHEL-SITE OFFICE, INDIRA GANDHI SUPER THERMAL POWER PROJECT, P.O. –JHARLI, DISTT. - JHAJJAR, HARYANA – 124141.
13. WARRANTY: NOT ACCEPTABLE.
14. MSE BIDDER: As per clause 11 of General Instruction to Bidders of GCC.
15. REVERSE AUCTION: APPLICABLE as per clause 10 of General Instruction to Bidders of GCC.
16. ORDER OF PRECEDENCE: In case of contradiction / conflict, the order of precedence shall be in the order as per clause 24 of General Commercial Terms & Conditions of GCC.

PART 'D'**UNPRICE SCHEDULE:** As per separate Attachment. Refer, Unprice Part (.xlsx file).**PART 'E'****PRICE SCHEDULE:** As a separate Attachment. Refer, Price Part (.xlsx file).**PART 'F'****GENERAL CONDITIONS OF CONTRACTS (GCC)**



**POWER SECTOR NORTHERN
REGION (PSNR)
PURCHASE DEPARTMENT**

**GENERAL CONDITIONS
OF CONTRACT (GCC)
REVISION NO. 00
ISSUED ON 24-08-2015**

GENERAL CONDITIONS OF CONTRACTS (GCC)

- 1. INSTRUCTIONS TO BIDDERS**
- 2. GENERAL COMMERCIAL TERMS & CONDITIONS**
- 3. ANNEXURES**

**POWER SECTOR NORTHERN REGION
BHARAT HEAVY ELECTRICALS LIMITED**

**HRDI & PSNR COMPLEX
PLOT NO. 25, SECTOR – 16A
NOIDA – 201301 (U.P.)**

Not for Publication

For Official Use

INSTRUCTIONS TO BIDDERS

TABLE OF CONTENTS

SL. NO.	DESCRIPTION
1.0	GENERAL INSTRUCTIONS
2.0	PROCEDURE FOR SUBMISSION & OPENING OF TENDERS
3.0	PART-I (TECHNO-COMMERCIAL BID) - CONTENTS & CHECKLIST
4.0	PART II (PRICE BID) - CONTENTS AND CHECK LIST
5.0	CLARIFICATIONS REQUIRED BY BIDDERS
6.0	DEVIATIONS - LISTING
7.0	VALIDITY OF OFFER
8.0	METRIC SYSTEM
9.0	EARNEST MONEY DEPOSIT (EMD)
10.0	REVERSE AUCTION
11.0	MICRO AND SMALL ENTERPRISE (MSE)
12.0	FRAUD PREVENTION POLICY
13.0	LANGUAGE & CORRECTIONS
14.0	PRICE DISCREPANCY



**POWER SECTOR NORTHERN
REGION (PSNR)
PURCHASE DEPARTMENT**

**GENERAL CONDITIONS
OF CONTRACT (GCC)
REVISION NO. 00
ISSUED ON 24-08-2015**

1.0 GENERAL INSTRUCTIONS:

- 1.1** Tenderers are advised to study all the tender documents carefully. Any submission of tender by the tenderer shall be deemed to have been done only after careful study and examination of the tender documents and with the full understanding of the implications thereof. The specifications and terms and conditions shall be deemed to have been accepted unless otherwise specifically commented upon in the deviation sheets by the tenderer in his offer. Non-compliance with any of the requirements and instructions of the Tender Enquiry may result in the rejection of the tender.
- 1.2** All commercial terms and conditions except price should be submitted as part of techno-commercial offer which may be opened first. The price part (Part-II) is to be submitted in a separate sealed cover along with techno-commercial offer (Part-I). Purchaser, however, reserves the right to open both the parts at the same time.
- 1.3** Price bids of only those bidders will be opened who will qualify for the subject job on the basis of evaluation of Techno-commercial bids / Qualifying criteria and as considered suitable by BHEL. BHEL shall have sole discretion to adopt its own method for evaluation of Techno-commercial bids/Qualifying Criteria.
- 1.4** No revision of price will be entertained after tenders are opened, unless mentioned in our enquiry/asked so by BHEL.
- 1.5** BHEL reserves the right to split, accept or reject any or all tenders without assigning any reason what so ever.

2.0 PROCEDURE FOR SUBMISSION & OPENING OF TENDERS:

- 2.1** Tender shall be submitted in **TWO PARTS** as described below on or before the DUE DATE and time indicated in the NIT.

PART – I : TECHNO-COMMERCIAL BID

Containing Technical offer, Annexure-I & II, Commercial Terms & Conditions and other relevant documents.

PART-II : PRICE BID

Containing Prices, to be submitted strictly as per enclosed Price Schedule Format for complete scope of the Tender Enquiry.

NOTE: Any changes in the specified price format, if made, other than those specified and accepted in the un-priced format, the offer is liable to be rejected.

- 2.1.1** PART-I (techno-commercial bid) shall be opened on the due date and time as specified in the NIT, in the presence of such of those tenderers or their authorized representatives who may be present. Incomplete offers are liable to be rejected. Purchaser reserves the right to open both the parts i.e. Part-I and Part-II together.

NOTE: In case the due date of opening of tender becomes a non-working day, then the due date & time of offer submission and opening of tenders get extended to the next working day.

- 2.1.2** PART-II containing prices shall be submitted along with Part-I, but in a separate sealed cover. Any corrections/ amendments shall be properly and fully authenticated. If not done so, the offer is liable to be rejected.

- 2.1.3** In case it becomes necessary for the tenderer to make any changes in his original price bid (Part-II) on account of technical/ commercial confirmations/ clarifications, owing to the changes made by the purchaser, to bring the offer in line with the requirement of the specifications, the impact of



**POWER SECTOR NORTHERN
REGION (PSNR)
PURCHASE DEPARTMENT**

**GENERAL CONDITIONS
OF CONTRACT (GCC)
REVISION NO. 00
ISSUED ON 24-08-2015**

such changes on price shall be submitted. Revised price bid only if requested by the purchaser shall be submitted, in a separate sealed cover. Impact/ Revised price bid shall be duly super scribed as:

**IMPACT/ REVISED PRICE BID (PART-II) (DELETE WHICHEVER IS NOT APPLICABLE), REVISION NO ____
AGAINST TENDER ENQ. NO. _____ DATED _____”.**

- 2.2 After the tenders have been technically & commercially examined and the necessary clarifications etc. obtained, Part-II containing FINAL REVISED PRICE BID, if submitted, otherwise, the original Price Bid along with price impact, if any, shall be opened, for which the date and time shall be intimated to the technically and commercially acceptable tenderers only, in case of public opening.

NOTE: BHEL also reserves the right to open the earlier price bids, if any, submitted by the bidders, if required.

- 2.3 No correspondence shall be entertained from the tenderers after the opening of Part-II (Price bid) of the tender.
- 2.4 Purchaser may negotiate the tender, if the quoted rates/terms are found to be unreasonable or in the unacceptable range.

2.5 MARKING ON ENVELOPES:

- 2.5.1 Following should be super scribed on the envelopes of the two parts of the Bid.

PART I: TECHNO-COMMERCIAL BID:

TENDER FOR: _____

TENDER NO. _____ DUE ON: _____

PART II: PRICE BID:

TENDER FOR: _____

TENDER NO. _____

- 2.5.2 Both PART – I & PART – II should be individually sealed & super scribed as indicated above & shall be enclosed in one main envelope duly sealed & super scribed as:

**“TENDER FOR: _____ AGAINST TENDER ENQ. NO.
_____ DUE ON: _____ CONTAINING PART I AND PART II BIDS.”**

- 2.5.3 Envelope not marked with tender enquiry number is liable to be ignored and may not be opened.

2.6 BID SUBMISSION

- 2.6.1 The tenders shall be addressed to the official inviting Tenders by designation and sent at the following address:

**HEAD/PURCHASE, BHARAT HEAVY ELECTRICALS LTD., POWER SECTOR – NORTHERN REGION,
HRDI & PSNR COMPLEX, PLOT NO. 25, SECTOR – 16A, NOIDA – 201301 (U.P.)**

**And deposited in TENDER BOX, ROOM NO. 108 (PSNR), HRDI & PSNR Complex, PLOT NO. 25,
SECTOR – 16A, NOIDA – 201 301 (U.P.)**

- 2.6.2 Tenders can either be delivered in person or sent at the above mentioned address by **COURIER/ REGISTERED POST**, to the official inviting tender(s). It shall be the responsibility of the bidder to ensure that the tender is delivered in time. BHEL takes no responsibility for any delay/loss of documents or correspondences sent by courier/post.

- 2.7 Tenders received after the Specified time of their submission are treated as ‘**Late Tenders**’ and shall not be considered.

- 2.8 Unsolicited tenders will not be entertained.



**POWER SECTOR NORTHERN
REGION (PSNR)
PURCHASE DEPARTMENT**

**GENERAL CONDITIONS
OF CONTRACT (GCC)
REVISION NO. 00
ISSUED ON 24-08-2015**

2.9 All corrigenda, addenda, amendments and clarifications to this Tender will be hosted in the BHEL web page (www.bhel.com → [Tender Notifications](#) → [View Corrigendum](#)) and **not in the newspaper**. Bidders shall keep themselves updated with all such amendments.

3.0 PART-I (TECHNO-COMMERCIAL BID) – CONTENTS & CHECKLIST:

3.1 **Technical offer** shall contain:

1. Vendor confirmation regarding technical specification as specified in Tender.
2. Technical specifications/ write-ups.
3. Catalogues, literature & drawings/data sheets.
4. Recommended list of spare parts for three years operation as applicable.
5. Guarantee offered for the capacity of the system/ equipment.
6. Listing of **Technical Deviations**, if any.
7. Quality plans.
8. All other details/ documents as listed in tender documents.

3.2 **Commercial offer** shall contain:

1. Agreed terms & conditions (as per Annexure-II).
2. Listing of **Commercial Deviations**, if any.
3. Supporting documents against Qualifying Requirements (QR).
4. Acceptance to commercial terms and conditions by submitting duly signed and stamped all pages of Tender document as a proof of acceptance.
5. All other details/ documents as listed in tender documents.

4.0 PART II (PRICE BID) – CONTENTS AND CHECK LIST :

- 4.1 Bidder shall submit their offer prices in the given '**PRICE SCHEDULE FORMAT**' as specified in Tender.
- 4.2 The bidders should fully understand scope of supply and their responsibilities under the tender specifications before quoting. The bidders are required to quote strictly in the currency mention in the rate schedule in part-II price bid. Conditional price bid or price bid with any deviation are liable to be rejected. No cutting / erasing /overwriting shall be done in the price bid.

5.0 CLARIFICATIONS REQUIRED BY BIDDERS:

Technical and Commercial clarifications required, if any, before submission of tender, should be addressed (at least one day before the due date of submission of tender) to the official inviting the tenders.

6.0 DEVIATIONS – LISTING:

Tenders shall be submitted strictly in accordance with the requirements of tender documents. Deviations (Technical and Commercial), if any, shall be listed out separately. Technical deviations and Commercial deviations shall be furnished in separate sheets under headings "**TECHNICAL DEVIATIONS**" and "**COMMERCIAL DEVIATIONS**" respectively, along with reasons for taking such deviations. Deviations mentioned elsewhere but not included in the Schedule of Deviations as above shall not be accepted.

7.0 VALIDITY OF OFFER:

Offers should be valid for a **period of 90 days from the** date of Techno-Commercial bid (Part-I) opening.

8.0 METRIC SYSTEM:

Suppliers are requested to give metric measurements while quoting.



9.0 EARNEST MONEY DEPOSIT:

9.1 Tender must be accompanied by the prescribed amount of Earnest Money Deposit (EMD) in the manner described herein.

- a) EMD shall be furnished along with the offer in full as per the amount indicated in the Special Conditions of Contract (SCC) / NIT.
- b) EMD is to be paid in cash (as permissible under Income Tax Act), Pay order or Demand Draft in favour of “**BHARAT HEAVY ELECTRICALS LIMITED**” and payable at **NOIDA/ NEW DELHI**.
- c) No other form of EMD remittance shall be acceptable to BHEL.
- d) Bidders under MSE category as defined in Clause 10.0 of Instructions to Bidders shall be exempted from payment of earnest money.

9.2 EMD by the bidder will be forfeited as per Tender Documents if;

- a) After opening the tender, the bidder revokes his tender within the validity period or increases his earlier quoted rates.
- b) The bidder does not supply the material within the period as per P.O/Contract.

9.3 EMD shall not carry any interest.

9.4 In the case of unsuccessful bidders, the Earnest Money will be refunded to them within a reasonable time after acceptance of award by successful tenderer. In the case of successful bidder, the Earnest Money will be refunded after completion of supply of material as per P.O/Contract or converted to Security Deposit if applicable.

10.0 REVERSE AUCTION:

BHEL reserves the right to go for Reverse Auction (RA) instead of opening the sealed envelope price bid, submitted by the bidder. This will be decided after techno-commercial evaluation. All bidders to give their acceptance for participation in RA. Non-acceptance to participate in RA may result in non-consideration of their bids, in case BHEL decides to go for RA.

In case BHEL decides to go for Reverse Auction, only those bidders who have given their acceptance to participate in RA will be allowed to participate in the Reverse Auction. Those bidders who have given their acceptance to participate in Reverse Auction will have to necessarily submit „online sealed bid“ in the Reverse Auction. Non-submission of „online sealed bid“ by the bidder will be considered as tampering of the tender process and will invite action by BHEL as per extant guidelines in vogue.

(FOR DETAILS PLEASE REFER TO ANNEXURE – V).

11.0 MICRO & SMALL SCALE ENTERPRISES (MSE):

11.1 Any Bidder falling under MSE category, shall furnish the following details & submit documentary evidence/ Govt. Certificate etc. in support of the same along with their Techno-commercial offer;

Type under MSE	SC/ST owned	Others
Micro		
Small		

NOTE: - *If the bidder does not furnish the above, offer shall be processed construing that the bidder is not falling under MSE category.*



**POWER SECTOR NORTHERN
REGION (PSNR)
PURCHASE DEPARTMENT**

**GENERAL CONDITIONS
OF CONTRACT (GCC)
REVISION NO. 00
ISSUED ON 24-08-2015**

11.2 MSE suppliers can avail the intended benefits only if they submit along with the offer, attested copies of either EM – II certificate having deemed validity (Five years from the date of issue of acknowledgement in EM-II) or valid NSIC certificate or EM-II certificate along with attested copy of a CA certificate (**Format enclosed as per Annexure- X** where deemed validity of EM-II certificate of five years has expired) applicable for the relevant financial year (last audited). Date to be reckoned for determining the deemed validity will be the date of bid opening (Part 1 in case of two part bid). Non submission of such documents will lead to consideration of their bids at par with other bidders. No benefits shall be applicable for this enquiry if any deficiency in the above required documents are not submitted before price bid opening. If the tender is to be submitted through e-procurement portal, then the above required documents are to be uploaded on the portal. Documents should be notarized or attested by a Gazetted officer.

11.3 MSEs shall be exempted from payment of Tender fee.

11.4 MSEs shall be exempted from payment of earnest money at the time of tender deposit. However, there is no exemption of security deposit submission.

12.0 FRAUD PREVENTION POLICY:

The bidder along with its associate/collaborators/sub-contractors/sub-vendors/consultants/ service providers shall strictly adhere to BHEL Fraud Prevention Policy displayed on BHEL website <http://www.bhel.com> and shall immediately bring to the notice of BHEL Management about any fraud or suspected fraud as soon as it comes to their notice.

13.0 LANGUAGE & CORRECTIONS:

- a) Tenderer shall quote the rates in English language and international numerals only. These rates shall be entered in figures as well as in words. For the purpose of tender, metric system of units shall be used.
- b) All entries in the tender shall either be typed or written legibly in ink. Cancellations, insertions, erasement, over-writing (if unavoidable) shall be authenticated with signature and seal by the bidder.
- c) Tenderer's offer, remarks and deviations shall be with reference to sections and clause numbers given in the tender documents.

14.0 PRICE DISCREPANCY:

Following shall be considered for evaluation and ordering for non-conformities/errors/ discrepancies in price bid:

- a) If, in the price structure quoted for the required goods/ services/ works, there is discrepancy between the unit price and the total price (which is obtained by multiplying the unit price by the quantity), the unit price shall prevail and the total price corrected accordingly, unless in the opinion of the Purchaser there is an obvious misplacement of the decimal point in the unit price, in which case the total price as quoted shall govern and the unit price corrected accordingly.
 - b) If there is an error in a total corresponding to the addition or subtraction of subtotals, the subtotals shall prevail and the total shall be corrected.
 - c) If there is a discrepancy between words and figures, the amount in words shall prevail, unless the amount expressed in words is related to an arithmetic error, in which case the amount in figures shall prevail subject of (a) and (b) above.
 - d) Taxes and duties if not specified clearly as extra shall be considered as included in the basic price and, therefore, shall not be reimbursed.
-

GENERAL COMMERCIAL TERMS & CONDITIONS

TABLE OF CONTENTS

Sl. No.	DESCRIPTION
1.0	DEFINITION OF TERMS
2.0	PRICES
3.0	INSPECTION
4.0	INSURANCE
5.0	PACKING AND MARKING
6.0	DELIVERY
7.0	REJECTION
8.0	SHORTAGE/ DAMAGES
9.0	TERMS OF PAYMENT
10.0	PERFORMANCE BANK GUARANTEE (PBG)
11.0	GUARANTEE/ WARRANTY FOR EQUIPMENT/STORES
12.0	RECOVERY OF OUTSTANDING AMOUNT
13.0	INDEMNIFICATION
14.0	DELAY/ TIME EXTENSION
15.0	LIQUIDATED DAMAGES (LD)
16.0	TERMINATION
17.0	TRANSFER, SUB-LETTING/ASIGNMENT/SUB-CONTRACTING
18.0	FORCE MAJEURE
19.0	SETTLEMENT OF DISPUTES
20.0	ARBITRATION
21.0	LAWS GOVERNING THE CONTRACT
22.0	JURISDICTION OF COURT
23.0	AMENDMENTS
24.0	ORDER OF PRECEDENCE
25.0	DEALING WITH BANNED SUPPLIERS/ CONTRACTORS IN BHEL
26.0	SUSPENSION OF BUSINESS DEALINGS
27.0	SUPPLIER PERFORMANCE RATING (SPR) SYSTEM



**POWER SECTOR NORTHERN
REGION (PSNR)
PURCHASE DEPARTMENT**

**GENERAL CONDITIONS
OF CONTRACT (GCC)
REVISION NO. 00
ISSUED ON 24-08-2015**

1.0 DEFINITION OF TERMS:

- 1.1 PURCHASER** shall mean M/s Bharat Heavy Electricals Limited (A Govt. of India Undertaking) incorporated under the Companies Act 1956 having its Registered office at BHEL House, Siri Fort, New Delhi – 110049 acting through its **Power Sector – Northern Region**, HRDI & PSNR COMPLEX, PLOT NO. 25, SECTOR – 16A, NOIDA – 201 301 (U.P.) which expression shall include its successors, authorized representatives and permitted assigns. It may also be referred to as **BHEL**.
- 1.2 TENDERER/ BIDDER** shall mean the Firm/ Company/ Organisation which quotes against the Tender Enquiry issued by Purchaser.
- 1.3 SELLER/ CONTRACTOR/ SUPPLIER/ VENDOR** shall mean the successful bidder with whom the Order/ Contract is made.
- 1.4 GCC** means General Conditions of Contract.
- 1.5 GOODS/ STORE** means all the items, materials, equipment and/or machinery, which the supplier is required to supply to the purchaser in terms of a contract.
- 1.6 SERVICES** means the services ancillary to the supply of the goods, such as transportation and insurance and as any other incidental services, such as installation, commissioning, provision of technical assistance, training and other such obligation of the supplier covered under a contract.
- 1.7 CONSIGNEE** means the individual or body to whom the contracted goods are required to be delivered as per the terms and conditions incorporated in a contract.
- 1.8 DAY** means calendar day of the Gregorian Calendar.
- 1.9 MONTH** means calendar month of the Gregorian Calendar.

2.0 PRICES:

Prices shall be for the entire scope of work in line with all instructions, specifications and terms & conditions specified in the tender documents.

3.0 INSPECTION:

Inspection for the stores will be carried out at the Seller's works/ Purchaser's Destinations/ Sites by the Purchaser's authorized inspecting officer. Wherever preliminary or stage Inspection is to be carried out at the seller's works the same will be subject to final acceptance/after receipt of the stores at the Purchaser's works / Destinations/ Site as the case may be and the decision of the purchaser shall be final. Rejected goods will be returned to the supplier at his cost including freight on original shipment.

4.0 INSURANCE:

- 4.1** Wherever Transit insurance is under Vendor's Scope, the Vendor will insure at his cost the goods for all transit risks.
- 4.2** In all other cases, Vendors shall inform the Underwriters, appointed/ nominated by BHEL/ Purchaser, the details of despatches under intimation to BHEL such as LR No. and date, Truck No., P.O. No., project and value. The details of underwriter shall be collected by the Vendor before dispatch of material from their works. Failure to do this will make the Vendor responsible for making goods any loss which might have otherwise been recovered from insurers.

5.0 PACKING AND MARKING:

- 5.1** Packing shall be in conformity with specifications and shall be such as to ensure prevention of damages, corrosion, deterioration, shortages, pilferage and loss in transit or storage. In case of



**POWER SECTOR NORTHERN
REGION (PSNR)
PURCHASE DEPARTMENT**

**GENERAL CONDITIONS
OF CONTRACT (GCC)
REVISION NO. 00
ISSUED ON 24-08-2015**

shipment by sea, the packing shall be sea-worthy. If any damage deterioration or loss is sustained when the carrier or underwriter attributed to improper/defective packing the seller shall be liable to replace the stores at his cost or reimburse the value of the loss to the purchaser notwithstanding whether the insurance is arranged by him or not.

5.2 The following marking shall be made on each package in Black bold capital letters;

- a) Name & Address of Consignee
- b) Dimension of Package
- c) Weight details (Gross & Net)

5.3 These markings should be stenciled or written in bold letters on the package. Should the package be small suitable cards/ metal tags giving these details may be tagged or nailed to such package.

6.0 DELIVERY:

The seller shall deliver the stores in accordance with the conditions of the purchase order at the time and at the place and in the manner specified thereunder. The risk in the stores shall not pass to the purchaser unless and until the stores have been duly accepted by the purchaser at the destination.

7.0 REJECTION:

The seller shall intimate the purchaser in writing, within 15 days after the receipt of rejection advice regarding disposal of the rejected stores. If no advice is received within aforesaid period the purchaser shall be at liberty to return the stores at the risk and cost of the seller after recovering the cost, if any paid by the purchaser including inward freight and other incidental charges. The purchaser will not be responsible for rejected stores thereafter and no claim whatsoever will rest on the purchaser.

8.0 SHORTAGES / DAMAGES:

If there are any shortages/damages in Equipment/ Stores found during receipt of material at Destination/ site, vendor shall supply replacements for same, as early as possible, at the old contractual rates upon intimation to vendor within 3 months of receipted LR. Decision of BHEL regarding shortages/damages shall be final and binding.

9.0 TERMS OF PAYMENT:

9.1 FOR SUPPLY PACKAGES:

9.1.1 Ninety percent (90%) of Ex -works price of materials supplied along with applicable 100% taxes and duties, insurance & freight shall be paid against the billing documents on pro-rata basis.

9.1.2 Ten percent (10%) of Ex - works of materials supplied will be released within 60 days from the date of receipt of material at Destination and submission of Form E1/ E2 against Form-C (if applicable).

Note: In extreme case, if vendors not agreeing to clause 9.1.2 as above then their prices will be loaded as per Annexure-VI.

9.2 FOR SUPPLY PACKAGES WITH INSTALLATION/ COMMISSIONING/ DEMONSTRATION TEST AT SITE IN VENDOR'S SCOPE:

9.2.1 FOR SUPPLY PORTION:

9.2.1.1 Ninety percent (90%) of Ex-works price of materials supplied along with applicable 100% taxes and duties, insurance & freight shall be paid against the billing documents on pro-rata basis.



**POWER SECTOR NORTHERN
REGION (PSNR)
PURCHASE DEPARTMENT**

**GENERAL CONDITIONS
OF CONTRACT (GCC)
REVISION NO. 00
ISSUED ON 24-08-2015**

9.2.1.2 Ten percent (10%) of Ex-works price of materials supplied will be released after submission of Installation/ Commissioning/ Demonstration Certificate duly certified by BHEL and Form E1/ E2 against Form-C (if applicable).

9.2.2 FOR INSTALLATION/ COMMISSIONING/ DEMONSTRATION PORTION:

100% Payment will be released after submission of Installation/ Commissioning/ Demonstration Certificate duly certified by BHEL.

9.3 FOR SUPPLY OF SPARES PARTS:

9.3.1 Ninety percent (90%) of Ex-works price of materials supplied along with applicable 100% taxes and duties, insurance & freight shall be paid against the billing documents.

9.3.2 Ten percent (10%) of Ex-works price of materials supplied will be released within 60 days from the date of receipt of material at Destination.

9.4 BILLING DOCUMENTS FOR 90% PAYMENT :

9.4.1 FOR SUPPLY PACKAGE:

1. Original tax Invoices
2. Copy of LR
3. Copy of Test Certificate
4. Copy of MDCC (if applicable)
5. Original copy of SRV duly certified by BHEL Site official.

9.4.2 FOR SUPPLY PACKAGES WITH COMMISSIONING / DEMONSTRATION TEST AT SITE:

1. Original tax Invoices
2. Copy of LR
3. Warranty Certificate for the goods.
4. Calibration Certificates/Mfg. Test Certificate.
5. Original copy of SRV duly certified by BHEL Site official.
6. O&M Manuals.
7. Performance Bank Guarantee

9.4.3 FOR SUPPLY OF SPARE PARTS:

1. Original tax Invoices
2. Copy of LR
3. Warranty Certificate for the goods (If applicable)
4. Original copy of SRV duly certified by BHEL Site official.

9.5 Vendors shall submit documents for payment directly to BHEL. Payment will be released within **30 days** from the date of receipt of clear & complete documents as per Purchase Order.

9.6 LOADING DETAILS IN CASE OF DEVIATIONS:

Loading details in respect to deviations in Payment Terms, LD, Guarantee/ Warranty & PBG will be as indicated in Annexure – VI.

9.7 MODE OF PAYMENT:

Payments shall be made directly to the Seller/ Contractor by E-transfer. Seller/ Contractor will provide necessary information for the same as per Annexure – VII to the Purchaser.

9.8 No interest shall be payable by the Purchaser on the Bank guarantee amount or balance payment or any money which may become due owing to difference or misunderstanding or any dispute between the Purchaser and the Contractor, or any delay on the part of Purchaser in making periodical or final payment or any other aspects incidental thereto.



**POWER SECTOR NORTHERN
REGION (PSNR)
PURCHASE DEPARTMENT**

**GENERAL CONDITIONS
OF CONTRACT (GCC)
REVISION NO. 00
ISSUED ON 24-08-2015**

10.0 PERFORMANCE BANK GUARANTEE (PBG):

- 10.1** PBG shall be applicable in case of supply packages with Commissioning / Demonstration test at site in vendor's scope.
- 10.2** The Vendor shall furnish Bank guarantee (in line with format as per **Annexure –VIII**) equal to **10% of the Order value excluding taxes & duties** before first submission of documents for payment to cover the due performance of order/ contract and to fulfil the guarantee conditions stipulated in the order/ contract.
- 10.3** The Bank guarantee shall be kept valid at all times during the entire Guarantee period and as advised by the Purchaser (as mentioned in clause 11.0 of General Commercial Terms & Conditions of GCC).
- 10.4** Purchaser reserves the right to encash the bank guarantee and forfeits the amount in the event of any default, failure or neglect on part of the Seller/ Contractor/Vendor in fulfilment of performance of the Order/ Contract.
- 10.5** An amount equivalent to the value of Bank Guarantee shall be retained by the Purchaser from the payments due to the Seller/ contractor/ Vendor before releasing any payment, in the absence of a valid Bank Guarantee.
- 10.6** Bank Guarantees shall be from Consortium Bank as per Annexure – IX. In case of bank guarantee from any other bank, BHEL shall get confirmation from the consortium bank, for which the confirmation charges will be borne by the vendor. Bank guarantees from co-operative banks/ non-scheduled banks are not acceptable.
- 10.7** In case of private sector banks, a clause to be incorporated in the text of BG that it can be enforceable by being presented **at any branch** of the bank.

11.0 GUARANTEE / WARRANTY FOR EQUIPMENT/ STORES:

- 11.1** Seller/ Contractor/ Vendor shall warrant that the stores supplied shall be free from all defects and faults in design & engineering, material, workmanship & manufacture and shall be of the highest grade and consistent with the established and generally accepted standards and in full conformity with the Order/ Contract specifications, drawing or samples, if any.
- 11.2 a)** Guarantee period for Supply package with Commissioning / Demonstration test at site in Vendor's scope shall be, 18 (Eighteen) calendar months from the date of last dispatch or 12 (Twelve) calendar months from the date of satisfactory Commissioning or Demonstration of the package, whichever is earlier.
- b)** Guarantee period for **Supply of Spare Parts** shall be 12 (Twelve) calendar months from the date of last dispatch.
- 11.3** Rectification / replacement required during the warranty period shall be arranged by the supplier free of cost including to and fro transport charges, import duty/excise duty/other taxes/insurance etc. payable on the items rectified and/or replaced.

12.0 RECOVERY OF OUTSTANDING AMOUNT:

In event of any amount of money being outstanding at any point of time against the Seller/ Contractor/ Vendor due to excess payment or any other reason whatsoever, in the present order/ contract or any other order/ contract from any BHEL Unit, the outstanding amount shall be recovered from the payments due to the Seller/ Contractor/ Vendor at any appropriate time and manner/ mode as deemed fit by the Purchaser from this or any other order/ contract of any BHEL unit at its sole discretion.

13.0 INDEMNIFICATION:

Seller/ Contractor/ Vendor shall fully indemnify and keep indemnified the Purchaser against all claims of whatsoever nature arising during the course and out of the execution of this Order/Contract.



**POWER SECTOR NORTHERN
REGION (PSNR)
PURCHASE DEPARTMENT**

**GENERAL CONDITIONS
OF CONTRACT (GCC)
REVISION NO. 00
ISSUED ON 24-08-2015**

14.0 DELAY/ TIME EXTENSION:

The Supplier shall Timely dispatch/ deliver and complete the other schedules as stipulated in Order/ Contract. If the Seller/ Contractor fails to complete the dispatch/ delivery and other schedules within the time period stipulated in Order/ Contract, or within any extension of time granted by Purchaser, it shall be lawful for Purchaser to recover damages for breach of Order/ Contract without prejudice to any other rights and/ or remedies provided for, in the Order/ Contract and hereunder. For any delay not attributable to the Seller/ Contractor, the Seller/Contractor must report the same to the Purchaser immediately in writing only.

15.0 LIQUIDATED DAMAGES:

- a) LD shall be 0.5% of the total order value per week of delay or part thereof subject to a maximum of 10% of the total order value.
- b) In case of staggered delivery schedule, LD shall be 0.5% of the undelivered portion per week of delay or part thereof subject to a maximum of 10% of the total order value. However even if a staggered delivery schedule for Capital Machine is agreed, the LD cap will be levied on total order value and not undelivered portion of the order value.
- c) In case of any amendment/ revision, the LD shall be linked to the amended/ revised PO value.
- d) **LR/ GR/ RR date shall be treated as the date of dispatch for levying LD.**

16.0 TERMINATION:

16.1 The Purchaser, without prejudice to any other rights or remedies it may possess, may terminate the Contract in the following circumstances:

- a) if the Contractor becomes bankrupt or insolvent, has a receiving order issued against it, compounds with its creditors, or, if the Contractor is a corporation, a resolution is passed or order is made for its winding up (other than a voluntary liquidation for the purposes of amalgamation or reconstruction), a receiver is appointed over any part of its undertaking or assets, or if the Contractor being an individual or if a firm on a partnership thereof, is adjudged insolvent or has a receiving order for administration of his estate made against him or takes any proceeding for composition under any Insolvency Act for the time being in force or if the Contractor takes or suffers any other analogous action in consequence of debt.
- b) if the Contractor assigns or transfers the Contract or any right or interest therein in violation of the provision of Clause 17 (Assignment).
- c) if the Contractor, has engaged in corrupt or fraudulent practices in competing for or in executing the Contract.

For the purpose of this Sub-Clause :

"**Corrupt practice**" means the offering, giving, receiving or soliciting of anything of value to influence the action of a public official in the procurement process or in contract execution.

"**Fraudulent practice**" means a misrepresentation of facts in order to influence a procurement process or the execution of a contract to the detriment of the Purchaser and includes collusive practice among Bidders (prior to or after bid submission) designed to establish bid prices at artificial non-competitive levels and to deprive the Purchaser of the benefits of free and open competition.

- d) If the Contractor has abandoned or repudiated the Contract without assigning any reason.
- e) If the Contractor has without valid reason failed to commence work on the contract promptly or has suspended the progress of Contract performance for more than 07 (seven) days after receiving a written instruction from the Purchaser to proceed.



**POWER SECTOR NORTHERN
REGION (PSNR)
PURCHASE DEPARTMENT**

**GENERAL CONDITIONS
OF CONTRACT (GCC)
REVISION NO. 00
ISSUED ON 24-08-2015**

- f) If the Contractor persistently fails to execute the Contract in accordance with the Contract or persistently neglects to carry out its obligations under the Contract without just cause.
- g) If the Contractor refuses or is unable to provide sufficient goods or materials or any instalment thereof in the manner specified and within the Time specified in the contract.

16.2 Purchaser shall have the right to cancel Order/ Contract, wholly or in part, in case they are constrained to do so on account of any decline, diminution, curtailment or stoppage of their business. In such eventuality, the Seller/ Contractor shall make compensation claim in writing upon the purchaser. Thereafter, both the parties shall arrive at mutually acceptable compensation to be accorded to the Seller/ Contractor. The mutually acceptable compensation shall be final and binding upon both the parties.

16.3 The Purchaser shall have the right to cancel order/ contract at the risk and cost of Seller/ Contractor in case either the Seller/ Contractor himself or any of his representative or agent is found to have been an employee of the Purchaser or has within a period of two years of his retirement accepted the employment of the Seller/ Contractor either as a Seller/ Contractor or as an employee without having obtained prior permission of Purchaser.

16.4 In case of cancellation of main supply order/ contract, all other associated orders/ contracts like mandatory spares/ recommended spares/ E&C/ supervision of E&C shall stand cancelled.

16.5 Subject to Sub-Clause 16.6, the Contractor shall be entitled to be paid the Contract Price attributable to the materials supplied as on the date of termination. Any sums due to the Purchaser from the Contractor accruing prior to the date of termination shall be deducted from the amount to be paid to the Contractor under this Contract.

16.6 In case the Purchaser so desires, may procure upon such terms and in such manner as deemed appropriate, stores not so delivered or others of similar description where stores exactly complying with particulars are not, in the opinion of the Purchaser, which shall be final, readily procurable, at the risk and cost of the Seller/ Contractor and the Seller/ Contractor shall be liable to the Purchaser for any excess costs provided that the Seller/ Contractor shall continue the performance of the Order/ Contract to the extent not cancelled under the provisions of this clause. The Seller/ Contractor shall on no account be entitled to any gain on such repurchases. Cost of the purchases made by Purchaser at the risk and cost of Seller/ Contractor shall be worked out as follows:

"Excess cost (difference in values of new Awarded Contract/Purchase Order and old Awarded Contract/Purchase Order) plus 5% of Excess cost as overheads (Departmental charges) along with Liquidated Damages as applicable".

17.0 TRANSFER, SUB-LETTING/ ASSIGNMENT SUB-CONTRACTING:

Seller/ Contractor shall not sublet, transfer or assign order/ contract or any part thereof or interest therein or benefit or advantage thereof save with the prior consent in writing of Purchaser. In the event Seller/ Contractor sub-lets, transfers or assigns order/ contract or any part thereof or interest therein or benefit or advantage thereof without such permission, the Purchaser shall be entitled to cancel the Order/ Contract and to purchase the stores from elsewhere at risk and costs of Seller/ Contractor. In such eventuality the Seller/ Contractor shall be liable for any loss or damage which Purchaser may sustain in consequence of or arising out of such risk purchase.

18.0 FORCE MAJEURE:

18.1 "Force Majeure" shall mean any event beyond the reasonable control of the Purchaser or of the Seller/Contractor including but not limited to fire, flood, earthquake or other acts of God, war, riots, civil war and restraints of Governing States, as the case may be, and which is unavoidable



**POWER SECTOR NORTHERN
REGION (PSNR)
PURCHASE DEPARTMENT**

**GENERAL CONDITIONS
OF CONTRACT (GCC)
REVISION NO. 00
ISSUED ON 24-08-2015**

notwithstanding the reasonable care of the party affected. The following events are explicitly excluded from Force Majeure and are solely the responsibilities of the non-performing party: a) any strike, work-to-rule action, go-slow or similar labour difficulty (b) late delivery of equipment or material (unless caused by Force Majeure event) and (c) economic hardship.

18.2 If either party is prevented, hindered or delayed from or in performing any of its obligations under the Contract by an event of Force Majeure, then it shall notify the other in writing of the occurrence of such event and the circumstances thereof within 15 (fifteen) days after the occurrence of such event.

18.3 The party who has given such notice shall be excused from the performance or punctual performance of its obligations under the Contract for so long as the relevant event of Force Majeure continues and to the extent that such party's performance is prevented, hindered or delayed. The Time for Completion shall be extended by a period of time equal to period of delay caused due to such Force Majeure event.

18.4 Delay or non-performance by either party hereto caused by the occurrence of any event of Force Majeure shall not

(a) Constitute a default or breach of the Contract.

(b) Give rise to any claim for damages or additional cost or expense occasioned thereby, if and to the extent that such delay or non-performance is caused by the occurrence of an event of Force Majeure.

19.0 SETTLEMENT OF DISPUTES:

If any dispute arises between the Parties hereto during the subsistence of the order /contract or thereafter, arising out of or in connection with, the validity, interpretation, implementation or alleged breach of any provision of the order/ contract, the Parties hereto shall endeavour to settle such dispute amicably.

20.0 ARBITRATION:

20.1 In case of failure to arrive at amicable settlement, dispute of any kind whatsoever which arise between the Purchaser and the Seller/Contractor in connection with or arising out of the Order/Contract, including without prejudice to the generality of the foregoing, any question regarding its existence, validity or termination, or the execution of the contractual obligations whether before or after the termination, abandonment or breach of the Contract, shall be referred through prior notice in writing by either party to Arbitration.

20.2 Any dispute in respect of which a notice to commence arbitration has been given, in accordance with Sub-Clause 20.1, shall be finally settled by Arbitration.

20.3 Any dispute shall be referred to the sole arbitration of Unit Head of the Contracting Unit of the Purchaser or his nominee, within 45 days of the receipt of the notice invoking arbitration.

20.4 Subject as aforesaid, the Arbitration proceedings shall be conducted;

- a) In accordance with the rules of procedure of the Indian Arbitration and Conciliation Act 1996.
- b) The place of Arbitration shall be the place from which the contract is issued or such other place as the Arbitrator at his discretion may determine.
- c) The language of the Arbitration Proceedings shall be English.
- d) The law governing the arbitration proceeding shall be the Indian law and
- e) The cost of arbitration shall be borne equally by the parties.

The award of the Arbitrator shall be final and binding upon the parties to the dispute and shall be enforceable in any court of competent jurisdiction as decree of the court.



**POWER SECTOR NORTHERN
REGION (PSNR)
PURCHASE DEPARTMENT**

**GENERAL CONDITIONS
OF CONTRACT (GCC)
REVISION NO. 00
ISSUED ON 24-08-2015**

- 20.5** In case of Contract with Public Sector Enterprise (PSE) or a Government Department, the following shall be applicable:
“In the event of any dispute or difference relating to the interpretation and application of the provisions of the contracts, such dispute or difference shall be referred by either party for Arbitration to the sole Arbitrator in the Department of Public Enterprises to be nominated by the Secretary to the Government of India in-charge of the Department of Public Enterprises. The Arbitration and Conciliation Act, 1996 shall not be applicable to arbitration under this clause. The award of the Arbitrator shall be binding upon the parties to the dispute, provided, however, any party aggrieved by such award may make a further reference for setting aside or revision of the award to the Law Secretary, Department of Legal Affairs, Ministry of Law & Justice, Government of India. Upon such reference the dispute shall be decided by the Law Secretary or the Special Secretary/Additional Secretary, when so authorized by the Law Secretary, whose decision shall bind the Parties finally and conclusively. The Parties to the dispute will share equally the cost of arbitration as intimated by the Arbitrator”.
- 20.6** Notwithstanding any reference to the arbitration herein, the parties shall continue to perform their respective obligations under the Contract not affected by the issues governing arbitration unless they otherwise agree.
- 21.0 LAWS GOVERNING THE CONTRACT:**
The Contract, including all matters connected with contract, shall be governed by and interpreted in accordance with laws in force in India.
- 22.0 JURISDICTION OF COURT:**
The Courts at Delhi/ New Delhi shall have exclusive jurisdiction to decide the dispute, if any, in all matters arising under the contract(s) to which these conditions are applicable.
- 23.0 AMENDMENTS:**
No portion of this General Conditions of Contract may be altered or amended or changed, except by a writing signed by the parties in the form of an addendum.
- 24.0 ORDER OF PRECEDENCE:**
In case of contradiction / conflict, the order of precedence shall be in the order as per below;
- a) Amendments/Clarifications/Corrigenda/Errata etc., if any, issued in respect of the tender documents by BHEL.
 - b) Price Schedule
 - c) Technical Specifications
 - d) Special Conditions of Contract (SCC)
 - e) General Conditions of Contract (GCC)
- 25.0 DEALING WITH BANNED SUPPLIERS/ CONTRACTORS IN BHEL:**
Offers of the bidders, who are on the banned list, as also the offers of the bidders who engage the services of the banned firms, shall be rejected. The list of banned firms is available on BHEL website (www.bhel.com →Tender Notification →Banned Firms).
- 26.0 SUSPENSION OF BUSINESS DEALINGS:**
BHEL reserves the right to take action against Supplier/Contractor/ Vendor who either fail to perform or indulge in malpractices by “**Suspension business dealings**” with them in line with BHEL guidelines issued from time to time.
- 27.0 SUPPLIER PERFORMANCE RATING (SPR) SYSTEM:**
Seller / Supplier’s Performance will be evaluated as per Supplier Performance Rating System as described in **Annexure – XII**. The SPR System is applicable for Suppliers awarded against OPEN tender only.

ANNEXURES

ANNEXURE – I	OFFER SUBMISSION AS PER NIT
ANNEXURE – II	CHECK LIST
ANNEXURE – III	NO DEVIATION CERTIFICATE
ANNEXURE – IV	CERTIFICATE OF PRICE JUSTIFICATION
ANNEXURE – V	REVERSE AUCTION FORMAT
ANNEXURE – VI	LOADING CRITERION
ANNEXURE – VII	NEFT DETAILS
ANNEXURE – VIII	PERFORMANCE BANK GUARANTEE FORMAT
ANNEXURE – IX	LIST OF CONSORTIUM BANKS
ANNEXURE – X	CERTIFICATE BY CHARTED ACCOUNTANT ON LETTER HEAD
ANNEXURE – XI	NON DISCLOSURE CERTIFICATE
ANNEXURE – XII	SUPPLIER PERFORMANCE RATING (SPR)



**POWER SECTOR NORTHERN
REGION (PSNR)
PURCHASE DEPARTMENT**

**GENERAL CONDITIONS
OF CONTRACT (GCC)
REVISION NO. 00
ISSUED ON 24-08-2015**

ANNEXURE – I

OFFER SUBMISSION AS PER NIT

(To be Typed & submitted in the Letter Head of the Company/Firm of Bidder)

Ref. No. :

Dated :

**M/s Bharat Heavy Electricals Ltd.,
Power Sector Northern Region,
HRDI & PSNR COMPLEX,
PLOT NO. 25, SECTOR – 16A,
NOIDA – 201 301 (U.P.)**

ATTENTION:

Dear Sir,

Having examined the tender documents against your tender Enquiry No. _____ dated _____ and having understood the provisions of the said tender documents and having thoroughly studied the requirements of BHEL related to the work tendered for, in connection with

(name of work & project site), we hereby submit our offer for the proposed work in accordance with terms and conditions mentioned in the tender documents, at the prices quoted by us in your price schedule format and as per the indicated delivery schedule.

We have annexed to this tender the following documents:-

Part-I (Techno Commercial Bid) - in a properly sealed cover

- Complete Techno-Commercial Offer.
- Agreed Terms and Conditions (Annexure-II).
- Schedule of Commercial Deviations giving clause references.
- Schedule of Technical Deviations giving clause references.
- Signed & stamped copy of tender documents.
- Any other documents (Please specify).

Part-II (Price Bid) - in a separate, properly sealed cover in the format given by BHEL.

Thanking you,

Yours faithfully,

(Signature of the bidder with Name, Designation and Company's Seal)



ANNEXURE – II

CHECK LIST

NOTE: - Suppliers are required to fill in the following details in their Letterhead and no column should be left blank

A	Name and Address of the Supplier	
B	Details of Contact person for this Tender	Name : Mr/Ms Designation: Telephone No: Mobile No: Email ID:
C	DESCRIPTION	BIDDER'S CONFIRMATION (YES/ NO/ NA)
1	Whether Qualification Requirement (QR) Criteria is understood and provided proper supporting documents.	
3	Submission of Certificate of No Deviation as per Annexure – III	
4	Submission of Certificate of Price Justification as per Annexure – IV (<u>in case Single Tender</u>)	
5	Submission of Reverse Auction Format as per Annexure – V	
6	Submission of MSE certificate as specified in Tender	
7	Submission of Non-Disclosure Certificate as per Annexure - XI	
8	Submission of Unprice Format as specified in Tender	
9	Submission of Signed & Sealed copy of all pages of Tender	

NOTE: TENDER NOT ACCOMPANIED BY THE PRESCRIBED ABOVE APPLICABLE DOCUMENTS ARE LIABLE TO BE SUMMARILY REJECTED.

Date:

(Signatures of the Bidder with Name, Designation & Company's Seal)



**POWER SECTOR NORTHERN
REGION (PSNR)
PURCHASE DEPARTMENT**

**GENERAL CONDITIONS
OF CONTRACT (GCC)
REVISION NO. 00
ISSUED ON 24-08-2015**

ANNEXURE- III

CERTIFICATE OF NO DEVIATION

(To be Typed & submitted in the Letter Head of the Company/Firm of Bidder)

To,

(Write Name & Address of Officer of BHEL inviting the Tender)

Dear Sir,

Subject : No Deviation Certificate

Ref : 1) NIT/Tender Enquiry No:,
2) All other pertinent issues till date

We hereby confirm that we have not changed/ modified/materially altered any of the tender documents as downloaded from the website/ issued by BHEL and in case of such observance at any stage, it shall be treated as null and void.

We also hereby confirm that we have neither set any Terms and Conditions and nor have we taken any deviation from the Tender conditions together with other references applicable for the above referred NIT/Tender Enquiry.

We further confirm our unqualified acceptance to all Terms and Conditions, unqualified compliance to Tender Conditions.

We confirm to have submitted offer in accordance with tender instructions and as per aforesaid references.

Thanking you,

Yours faithfully,
**(Signatures of the Bidder
with Name, Designation & Company's Seal)**



**POWER SECTOR NORTHERN
REGION (PSNR)
PURCHASE DEPARTMENT**

**GENERAL CONDITIONS
OF CONTRACT (GCC)
REVISION NO. 00
ISSUED ON 24-08-2015**

ANNEXURE- IV

CERTIFICATE OF PRICE JUSTIFICATION*

(To be Typed & submitted in the Letter Head of the Company/Firm of Bidder)

TENDER No. : _____ Date: _____

I/ WE, M/s

HEREBY CERTIFY THAT RATES PROVIDED ARE OUR BEST RATES AND WE HAVE NOT GIVEN THESE MATERIALS TO ANY PARTY FOR LESSER THAN THESE RATES IN LAST ONE YEAR.

(Signatures of the Bidder with Name, Designation & Company's Seal)

*** Certification Of Price Justification is applicable for Single tender only.**



ANNEXURE- V

REVERSE AUCTION (RA) FORMAT

BHEL reserves the right to go for Reverse Auction (RA) instead of opening the sealed envelope price bid, submitted by the bidder. This will be decided after techno-commercial evaluation. Bidders are also required to furnish following details in their techno-commercial bid, for this purpose.

Information and general terms and conditions governing RA are given below.

In case BHEL decides to process the tender through Reverse Auction Process (RA), following details shall be required from the bidders for their authorized representative who will participate in the on line Reverse Auction Process;

(a) Name of Designation of official:

(b) Postal Address (Complete):

(c) Telephone Nos. (Land line & Mobile both):

(d) FAX No.:

(e) E-mail address:

(f) Name of Place/State/Country, wherefrom he will participate in the RA:

(Signatures of the Bidder with Name, Designation & Company's Seal)

TERMS & CONDITIONS OF REVERSE AUCTION

Against this enquiry for the subject item/ system with detailed scope of supply as per enquiry specifications, BHEL may resort to "REVERSE AUCTION PROCEDURE" i.e., ON LINE BIDDING (THROUGH A SERVICE PROVIDER). The philosophy followed for reverse auction shall be English Reverse (No ties).

1. For the proposed reverse auction, technically and commercially acceptable bidders only shall be eligible to participate.



**POWER SECTOR NORTHERN
REGION (PSNR)
PURCHASE DEPARTMENT**

**GENERAL CONDITIONS
OF CONTRACT (GCC)
REVISION NO. 00
ISSUED ON 24-08-2015**

2. Those bidders who have given their acceptance for Reverse Auction (quoted against this tender enquiry) will have to necessarily submit „online sealed bid“ in the Reverse Auction. Non-submission of „online sealed bid“ by the bidder for any of the eligible items for which techno-commercially qualified, will be considered as tampering of the tender process and will invite action by BHEL as per extant guidelines in vogue.
3. BHEL will engage the services of a service provider who will provide all necessary training and assistance before commencement of on line bidding on internet.
4. In case of reverse auction, BHEL will inform the bidders the details of Service Provider to enable them to contact & get trained.
5. Business rules like event date, time, bid decrement, extension etc. also will be communicated through service provider for compliance.
6. Bidders have to fax the Compliance form before start of Reverse auction. Without this, the bidder will not be eligible to participate in the event.
7. In line with the NIT terms, BHEL will provide the calculation sheet (e.g., EXCEL sheet) which will help to arrive at “Total Cost to BHEL” like Packing & forwarding charges, Taxes and Duties, Freight charges, Insurance, Service Tax for Services and loading factors (for non-compliance to BHEL standard Commercial terms & conditions) for each of the bidder to enable them to fill-in the price and keep it ready for keying in during the Auction.
8. Reverse auction will be conducted on scheduled date & time.
9. At the end of Reverse Auction event, the lowest bidder value will be known on auction portal.
10. The lowest bidder has to fax/e-mail the duly signed and filled-in prescribed format for price breakup including that of line items, if required, as provided on case-to-case basis to Service provider within two working days of Auction without fail.
11. In case BHEL decides not to go for Reverse Auction procedure for this tender enquiry, the Price bids and price impacts, if any, already submitted and available with BHEL shall be opened as per BHEL’s standard practice.
12. Bidders shall be required to read the “Terms and Conditions” section of the auctions site of Service provider, using the Login IDs and passwords given to them by the service provider before reverse auction event. Bidders should acquaint themselves of the „Business Rules of Reverse Auction“, which will be communicated before the Reverse Auction.
13. If the Bidder or any of his representatives are found to be involved in Price manipulation/ cartel formation of any kind, directly or indirectly by communicating with other bidders, action *as per extant BHEL guidelines*, shall be initiated by BHEL and the results of the RA scrapped/ aborted.
14. The Bidder shall not divulge either his Bids or any other exclusive details of BHEL to any other party.
15. In case BHEL decides to go for reverse auction, the H1 bidder(s) (whose quote is highest in online sealed bid) may not be allowed to participate in further RA process.



ANNEXURE – VI

LOADING CRITERIA

No deviation in Tender terms & conditions are generally acceptable and bids with deviation are liable to be rejected. However exceptional circumstances, BHEL may accept the deviations with loadings as given below;

1. PAYMENT TERMS:

Loading of any deviation in the Payment terms w.r.t NIT terms shall be as follows;

“Base rate of SBI (as applicable on the date of bid opening; Techno-commercial bid opening in case of two part bids) + 6%, shall be considered for loading for the period of relaxation sought by Bidder.”

2. LIQUIDATED DAMAGES/ PENALTY:

Any Loading on LD clause shall be to the extent to which it is not agreed to by the Bidder (at offered value).

3. GUARANTEE/ WARRANTY PERIOD:

No deviation is permitted

4. PERFORMANCE BANK GUARANTEE (PBG):

No deviation is permitted

5. DEVIATION TO CLAUSE 9.1.2 OF PAYMENT TERM, i.e. Ten percent (10%) of basic price of materials supplied will be released within 60 days from the date of receipt of material at Destination and submission of Form E1/ E2 against Form-C (if applicable):

10% of Basic price value

NOTE: Any new Loading factor/s arising out of Techno-commercial clarifications / discussions stage shall be intimated to all eligible Tenderers before opening of Price bid.



**POWER SECTOR NORTHERN
REGION (PSNR)
PURCHASE DEPARTMENT**

**GENERAL CONDITIONS
OF CONTRACT (GCC)
REVISION NO. 00
ISSUED ON 24-08-2015**

ANNEXURE – VII

NEFT DETAILS

Name of the party:

Name of the Bank:

Address of the Bank:

Party's A/c no:

Type of A/c:

IFSC CODE:

Vendor's E-MAIL ADDRESS:

(Signatures of the Bidder with Name, Designation & Company's Seal)

NOTE:

- THE ABOVE DETAILS ARE TO BE SUBMITTED ON THE COMPANY'S LETTERHEAD.
- THE DETAILS MAY EITHER BE ATTESTED BY YOUR BANKERS OR ACCOMPANIED BY A CANCELLED CHEQUE LEAF WITH IFSC CODE & A/C NO.PRINTED ON IT.
- UNDERTAKING TO REPORT IMMEDIATELY ANY CHANGES IN THE ABOVE TO BE SUBMITTED ON THE COMPANY'S LETTER HEAD



**POWER SECTOR NORTHERN
REGION (PSNR)
PURCHASE DEPARTMENT**

**GENERAL CONDITIONS
OF CONTRACT (GCC)
REVISION NO. 00
ISSUED ON 24-08-2015**

ANNEXURE- VIII

PERFORMANCE BANK GUARANTEE FORMAT

B.G. NO..... Date.....

This deed of Guarantee made this ----- day of ----- two thousand ----- by **<Name and Address of Bank>** hereinafter called the "The Guarantor" (which expression shall unless repugnant to the context or meaning thereof be deemed to include its successors and assigns) in favour of M/s Bharat Heavy Electrical Limited (A Govt. of India Undertaking) a company incorporated under the Companies Act, 1956, having its registered office at BHEL House, Siri Fort, Asiad, New Delhi – 110049 through its unit at Bharat Heavy Electricals Limited, Power Sector Northern Region, Plot No. 25, Sec – 16A, Distt. Gautam Budh Nagar, Noida 201301 hereinafter called "The Company" (which expression shall unless repugnant to the context or meaning thereof be deemed to include its successors and assigns).

WHEREAS **<Supplier's Name and Address>** (hereinafter referred to as the Supplier) have entered into a contract bearing No. **<P.O. No. & Date>** (hereinafter referred to as "the contract") for the supply of ----- with the company.

AND WHEREAS the contract inter-alia provides that the Supplier shall furnish to the company a sum of Rs.----- (Rupees-----) towards Performance Bond for due and faithful performance of the contract in the form and contents specified therein.

AND WHEREAS the Supplier has approached the Guarantor and in consideration of the arrangement arrived at between the Supplier and the Guarantor, the Guarantor has agreed to give the Guarantee as hereinafter mentioned in favour of the Company.

We **<Name of Bank>** the Guarantor do hereby guarantee to the Company the due and faithful performance, observance or discharge of the contract by the Supplier and further unconditionally and irrevocably undertake to pay to the Company without demur and merely on a demand, to the extent of Rs.----- (Rupees-----) against any claim by the Company on them for any loss, damage, costs, charges and expenses caused to or suffered by the Company by reasons of the Supplier making any default in the performance, observance or discharge of the terms, conditions, stipulations or undertakings or any of them as contained in the contract.

The decision of the Company whether any default has occurred or has been committed by the Supplier in the performance, observance or discharge of any of the terms, conditions, stipulations or undertakings or any one of them as contained in the contract and / or as to the extent of loss, damage, costs, charges and expenses caused to or suffered by the Company by reason of the Supplier making any default in the performance, observance or discharge of any of the terms, conditions, stipulations or undertakings or any one of them shall be conclusive and binding on the Guarantor irrespective of the fact whether the Supplier admits or denies the default or questions the correctness of any demand made by the Company in any Court, Tribunal or Arbitration proceedings or before any other Authority.

The Company shall have the fullest liberty without affecting in any way the liability of the Guarantor under this Guarantee, from time to time to vary any of the terms and conditions of the contract or extend time of performance by the Supplier or to postpone for any time and from time to time any of the powers exercisable by it against the Supplier and either enforce or forbear from enforcing any of the terms and conditions governing the contract or securities available to the Company and the Guarantor shall not be released from its liability under these presents by any exercise by the Company of the liberty with reference to the matters aforesaid or by reasons of time being given to the Supplier or any other forbearance, act or commission on the part of the Company or any indulgence by the Company to the Supplier or any other matter or thing whatsoever which under the law relating to sureties would, but for this provision have the effect of so releasing the Guarantor from its liability under this guarantee.



**POWER SECTOR NORTHERN
REGION (PSNR)
PURCHASE DEPARTMENT**

**GENERAL CONDITIONS
OF CONTRACT (GCC)
REVISION NO. 00
ISSUED ON 24-08-2015**

We <Name of Bank> the Guarantor further agrees that the Guarantee herein contained shall remain in full force and effect during the period that would be taken for the performance of the contract and its claim satisfied or discharged and till the company certifies that the terms and conditions of the contract have been fully and properly carried out by the Supplier and accordingly discharges this Guarantee, subject however, that the Company shall have no claim under this Guarantee after ----- i.e. (the present date of validity of Bank Guarantee unless the date of validity of this Bank Guarantee is further extended from time to time, as the case may be) unless a notice of the claim under this Guarantee has been served on the Guarantor before the expiry of the said period in which case the same shall be enforceable against the Guarantor notwithstanding the fact that the same is enforced after the expiry of the said period.

We <Name of Bank> the Guarantor undertakes not to revoke this Guarantee during the period it is in force except with the previous consent of the Company in writing and agrees that any liquidation or winding up or insolvency or dissolution or any change in the constitution of the Supplier or the Guarantor shall not discharge the Guarantor's liability hereunder.

It shall not be necessary for the Company to proceed against the Supplier before proceeding against the Guarantor and the Guarantee herein contained shall be enforceable against them notwithstanding any security which the Company may have obtained or obtain from the Supplier shall at the time when proceedings are taken against the Guarantor hereunder be outstanding or unrealized.

Notwithstanding anything contained herein before, our liability under the Guarantee is restricted to Rs.----- (Rupees-----). Our guarantee shall remain in force until -----, i.e. (the present date of validity of Bank Guarantee unless the date of validity of this Bank Guarantee is further extended from time to time) unless a claim or demand under this guarantee is made against us on or before ----- we shall be discharged from our liabilities under this Guarantee thereafter.

Any claim or dispute arising under the terms of this documents shall only be enforced or settled in the courts of at New Delhi/ Delhi only.

The Guarantor hereby declares that it has power to execute this guarantee and the executant has full powers to do so on behalf of the Guarantor.

IN WITNESS whereof the ----- (Bank) has hereunto set and subscribed its hand the day, month and year first, above written.

(Name of the Bank)
Signed for and on behalf of the Bank
(Designation of the Authorized Person Signing the Guarantee)
(Signatory No.-----)

DATED:
SEAL

Notes :

1. The BG shall be executed on non-judicial stamp paper of not less than Rs 100/- unless otherwise required under relevant statutes, procured in the name of the Bank in the State where the Bank is located. The BG should be only from the Consortium Bank as per Annexure – IX.
2. The BG is required to be sent by the executing Bank directly to BHEL at the address where tender is submitted / accepted under sealed cover.

ANNEXURE- IX

LIST OF CONSORTIUM BANK

	NATIONALISED BANK		PUBLIC SECTOR BANKS
1	Allahabad bank	20	IDBI
2	Andhra bank		FOREIGN BANK
3	Bank of Baroda	21	CITI Bank N.A
4	Canara Bank	22	Deutsche Bank AG
5	Corporation bank	23	The Hongkong and Shanghai Banking Corporation Limited
6	Central bank	24	Standard Chartered Bank
7	Indian Bank	25	The Royal Bank of Scotland N.V.
8	Indian Oversea Bank	26	J P Morgan
9	Oriental bank of Commerce		PRIVATE BANK
10	Punjab National Bank	27	Axis Bank
11	Punjab & Sindh Bank	28	The Federal Bank Limited
12	State Bank of India	29	HDFC
13	State Bank of Hyderabad	30	Kotak Mahindra Bank
14	Syndicate Bank	31	ICICI
15	State Bank of Travancore	32	Indusind Bank
16	UCO Bank	33	Yes Bank
17	Union Bank of India		
18	United Bank of India		
19	Vijaya Bank		



ANNEXURE- X

CERTIFICATE BY CHARTERED ACCOUNTANT ON LETTER HEAD

This is to certify that M/s. _____,
(hereinafter referred to as 'Company') having its registered office at _____
_____ is registered under MSMED Act 2006,
(Entrepreneur Memorandum No (Part II) _____ Dtd.
_____, Category: _____ (Micro/Small). (Copy Enclosed)

Further verified from the Book of Accounts that the investment of the company as per the latest audited Financial year _____ as per MSMED Act 2006 is as follows:

1. For Manufacturing Enterprises: Investment is plant and machinery (i.e., original cost excluding land and building and the items specified by the Ministry of Small Scale Industries vide its notification No. S.O. 1722(E) dated October 5, 2006:

Rs. _____ Lacs

2. For Service Enterprises: Investment in equipment (original cost excluding land and building and furniture, fittings and other items not directly related to the service rendered or as may be notified under the MSMED Act, 2006 :

Rs. _____ Lacs

(Strike off whichever is not applicable)

The above investment of Rs. _____ Lacs is within the permissible limit of Rs. _____ Lacs for _____ Micro/Small (*strike off which is applicable*) Category under MSMED Act 2006.

Or

The company has been graduated from its original category (Micro/ Small) (*Strike off which is not applicable*) and the date of graduation of such enterprise from its original category is (dd/mm/yyyy) which is within the period of 3 years from the date of graduation of such enterprise from its original category as notified vide S.O. No. 3322 (E) dated 01.11.2013 published in the gazette notification dated 04.11.2013 by Ministry of MSME.

Date:

(Signature)

Name –

Membership number –

Seal of Chartered Accountant



**POWER SECTOR NORTHERN
REGION (PSNR)
PURCHASE DEPARTMENT**

**GENERAL CONDITIONS
OF CONTRACT (GCC)
REVISION NO. 00
ISSUED ON 24-08-2015**

ANNEXURE- XI

NON DISCLOSURE CERTIFICATE

(To be Typed & submitted in the Letter Head of the Company/Firm of Bidder)

I/We understand that BHEL PSNR is committed to Information Security Management System as per their Information Security Policy.

Hence, I/We M/s
Who are submitting offer for providing services to BHEL PSNR against Tender Enquiry No..... hereby undertake to comply with the following in line with Information Security Policy of BHEL PSNR.

- To maintain confidentiality of documents & information which shall be used during the execution of the Contract.
- The documents & information shall not be revealed to or shared with third party which shall not be in the business interest of BHEL PSNR.

Date:

**(Signatures of the Bidder with Name,
Designation & Company's Seal)**



**POWER SECTOR NORTHERN
REGION (PSNR)
PURCHASE DEPARTMENT**

**GENERAL CONDITIONS
OF CONTRACT (GCC)
REVISION NO. 00
ISSUED ON 24-08-2015**

(ANNEXURE – XII)

SUPPLIER PERFORMANCE RATING (SPR)

(TO BE SUBMITTED AFTER COMPLETION OF TOTAL SUPPLY AS PER P.O.)

PURCHASE ORDER NO.	
DESCRIPTION OF ITEM	
NAME OF SUPPLIER	
PROJECT SITE	

Supplier performance shall be assessed taking into account the following main factors and calculated for each consignment/ purchase order:

RATING	WEIGHTAGE
QUALITY	40
DELIVERY	50
SERVICE	10
TOTAL	100

(A) Quality Rating (QR):

Quality rating is based on acceptable quantity of material offered for inspection or delivered by supplier and shall be calculated as:

$$\text{Quality Rating (QR)} = \frac{(Q1 + 0.75 \times Q2 + 0 \times Q3) \times 40}{Q}$$

- Q : Total Quantity as per PO & its amendments
 Q1 : Quantity accepted
 Q2 : Quantity accepted with concession/ deviation/rectification
 Q3 : Quantity rejected

(B) Delivery Rating (DR):

Supplier will be rated on delivery parameters wherein Delivery rating shall be 50 in case of adherence to PO delivery. For non-adherence to PO delivery (i.e. delay in supply), marks to be deducted in proportion of delay to PO delivery.

Deduction = (delay in days/PO delivery in days) x 100

DR = 50 – Deduction (Limited to Weightage '0')

Note: In cases, where delay is on account of BHEL in providing raw materials/ tools/ any other input, the delivery shall be extended with amendment to PO.

(C) Service Rating (SR):

The criteria for service rating shall be based on the Demerit factor (negative rating) to be updated by the User/ MM group. The service rating shall be 10, in case there is no negative feedback against the Supplier for the given supply. Else, the service rating should be reduced proportionally based on the Demerit factor.

SUPPLIER PERFORMANCE RATING (SPR) = QR + DR + SR

RATING FACTOR	QUALITY RATING (QR) (MAX. 40)	DELIVERY RATING (DR) (MAX. 50)	SERVICE RATING (SR) (MAX. 10)	SPR = QR + DR + SR (Max. 100)
POINTS OBTAINED				

Note: (1) In case Supplier Performance Rating (SPR) falls below 60% against any Purchase Order, then the Supplier shall put on **HOLD for a period of 1 year** against supply of the said material/category.

(2) In case supplier needs any assistance from BHEL for improvement they can contact the MM Department.

General Remarks, if any:

(Signed by Site MM Incharge)

CC: Original Copy to be forwarded to Head/Purchase, PSNR-Noida.