

ALL DIMENSIONS ARE IN MM

IT MUST NOT BE USED DIRECTLY OR INDIRECTLY IN ANYWAY DETERMINANT TO INTEREST OF THE COMPANY

REV 01	DATE	ALTERED
		CHECKED
		APPROVED

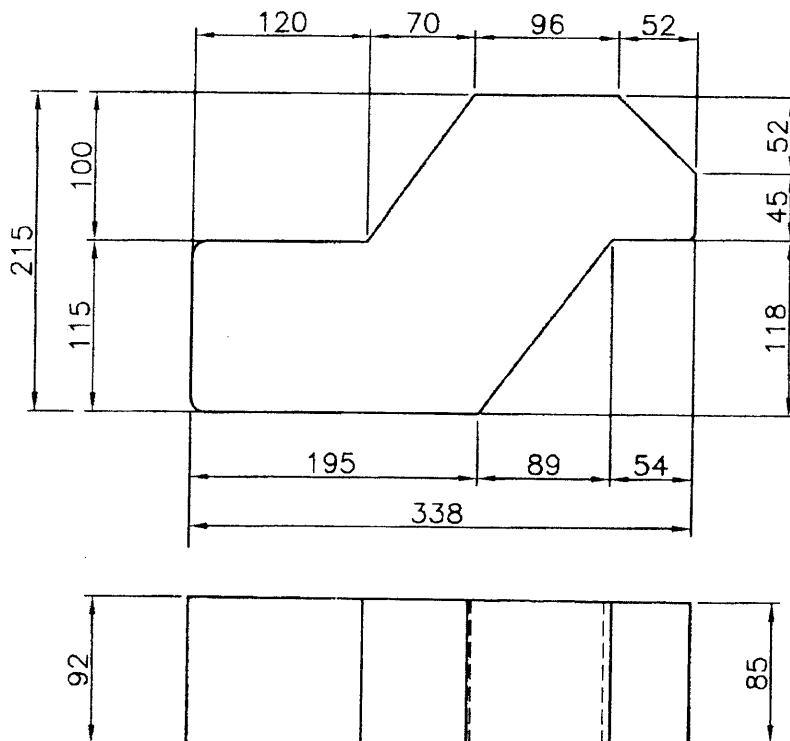



**NOTES:**

1. THE REFRACTORIES SHALL BE COMPACT, OF HOMOGENEOUS TEXTURE AND FREE FROM CRACKS, VOIDS AND OTHER FLAWS, THEY SHALL BE BURNT EVENLY THROUGHOUT, AND SHALL HAVE SUFFICIENT MECHANICAL STRENGTH AND NO SOFT CORNERS.
2. ALL CORNERS TO BE MINIMUM 3 mm. RADII, UNLESS OTHERWISE STATED.
3. TOLERANCE ON SIZE  $\begin{matrix} +0 \\ -0.1 \end{matrix}$

			80% AL <sub>2</sub> O <sub>3</sub>	300
ITEM NO	DESCRIPTION	DRAWING NO	MATL CODE	UNIT WT
			MATL SPEC	QTY

EQPT: **ROTARY HEARTH FURNACE**

		<b>Bharat Heavy Electricals Ltd</b> SEAMLESS STEEL TUBE PLANT TIRUCHIRAPALLI - 620014		DRN	NAME <b>SSN.KUMAR</b>	SIGNATURE <i>SSN.Kumar</i>	DATE <b>15.12.04</b>
				CHD			
				APPD	<b>S.SHANMUGASUNDARAM</b>	<i>S. Shanmugasundaram</i>	<b>16/12/04</b>
DEPT <b>MPG</b>	GRADE OF UNTOL. DIM <i>Q/M/F</i>		SCALE <b>1:5</b>	WEIGHT (Kg) <b>11.4</b>	REF TO ASSY DRG		ITEM NO
CODE					REF TO OLD DRG <b>FA-0427-3/5</b>		
TITLE <b>HEARTH MIDDLE INNER CIRCLE BLOCK</b>				CARD CODE <b>U 01</b>	DRAWING NO : <b>4-7-1101-01-06281</b>		REV <b>00</b>

CAUTION: THE INFORMATION ON THIS DOCUMENT IS THE PROPERTY OF BHARAT HEAVY ELECTRICALS LTD  
IT MUST NOT BE USED DIRECTLY OR INDIRECTLY IN ANYWAY TERMINAL TO INTEREST OF THE COMPANY

ALL DIMENSIONS ARE IN MM

REV 01	DATE	ALTERED
		CHECKED
		APPROVED

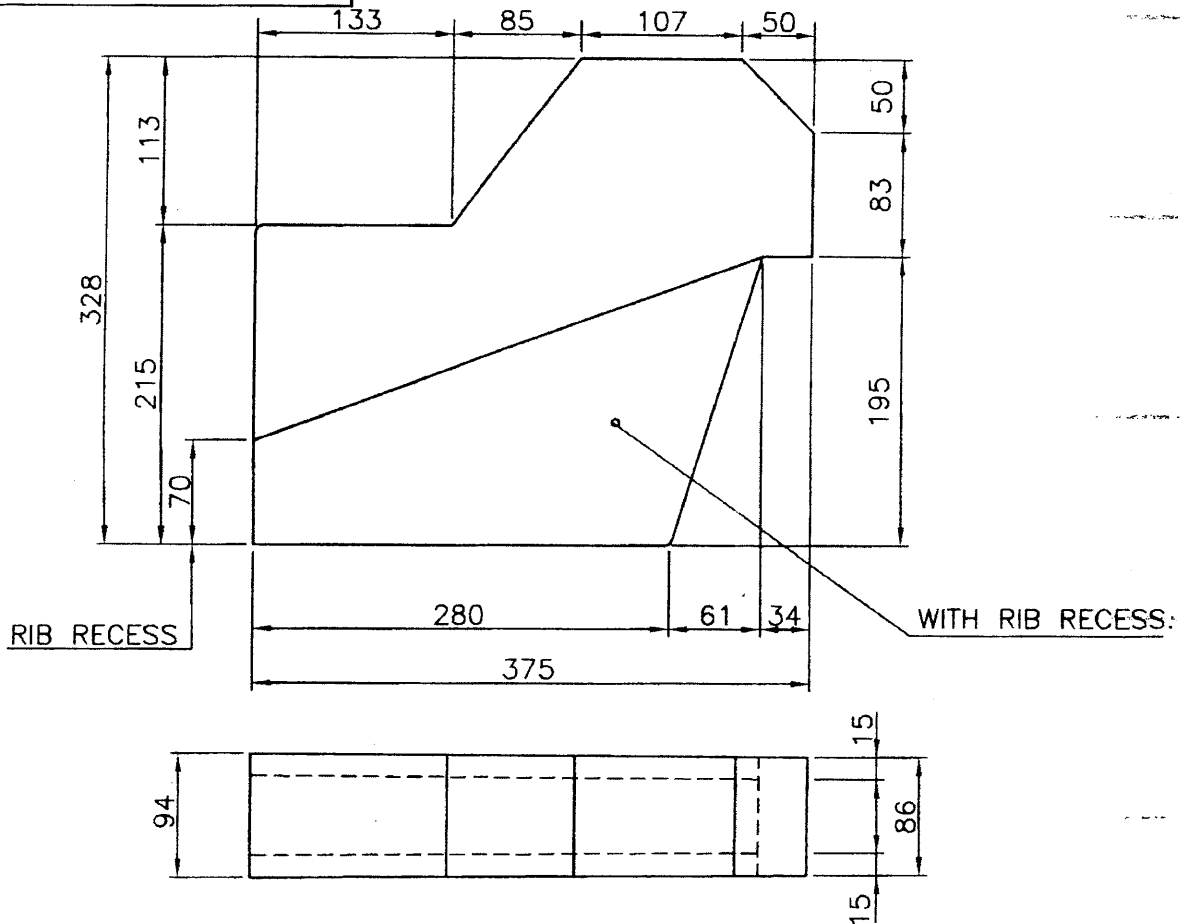

**NOTES:**

1. THE REFRACTORIES SHALL BE COMPACT, OF HOMOGENEOUS TEXTURE AND FREE FROM CRACKS, VOIDS AND OTHER FLAWS, THEY SHALL BE BURNT EVENLY THROUGHOUT, AND SHALL HAVE SUFFICIENT MECHANICAL STRENGTH AND NO SOFT CORNERS.
2. ALL CORNERS TO BE MINIMUM 3 mm.RADII, UNLESS OTHERWISE STATED.
3. TOLERANCE ON SIZE  $\begin{matrix} +0 \\ -1 \end{matrix}$

			80% AL <sub>2</sub> O <sub>3</sub>	288
ITEM NO	DESCRIPTION	DRAWING NO	MATL CODE	UNIT WT
			MATL SPEC	QTY

EQPT: **ROTARY HEARTH FURNACE**

	Bharat Heavy Electricals Ltd		DRN	NAME	SIGNATURE	DATE
	SEAMLESS STEEL TUBE PLANT		CHD	SSN.KUMAR	S.S.N. Kumar	15.12.04
	TIRUCHIRAPALLI - 620014		APPD	S.SHANMUGASUNDARAM	<i>S. Shanmugasundaram</i>	16/12/04

DEPT MPG	GRADE OF UNTOL DIM ϕ/M/F	SCALE 1:5	WEIGHT (Kg) 20.4	REF TO ASSY DRG	ITEM NO
CODE				REF TO OLD DRG FA-0427-3/7	

TITLE <b>HEARTH BOTTOM INNER CIRCLE BLOCK</b>	CARD CODE U 01	DRAWING NO : <b>4-7-1101-01-06283</b>	REV <b>00</b>
--	----------------------	--	------------------

02

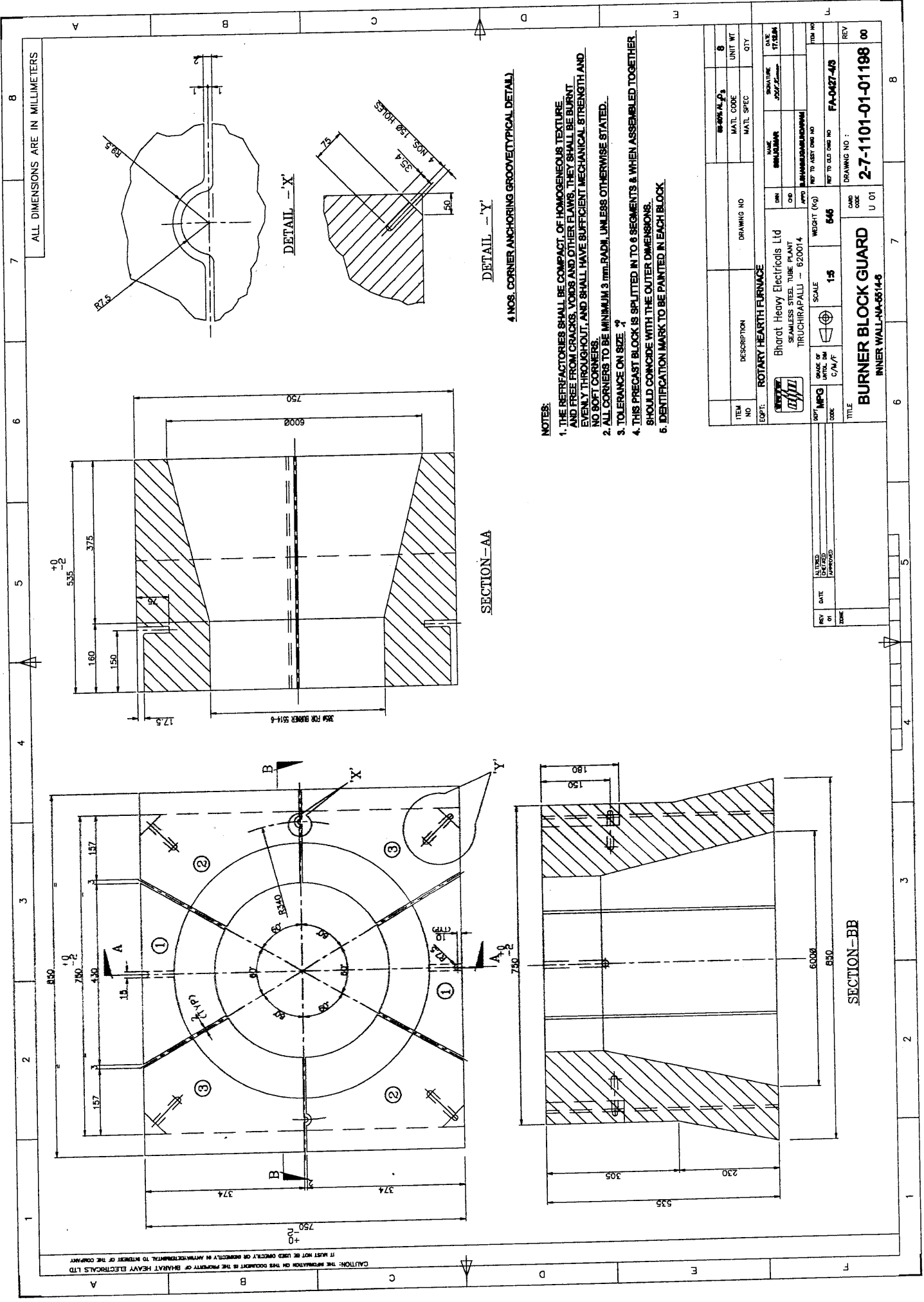

- NOTES:**
1. THE REFRACTORIES SHALL BE COMPACT OF HOMOGENEOUS TEXTURE AND FREE FROM CRACKS, Voids AND OTHER FLAWS. THEY SHALL BE BURNT EVENLY THROUGHOUT, AND SHALL HAVE SUFFICIENT MECHANICAL STRENGTH AND NO SOFT CORNERS.
  2. ALL CORNERS TO BE MINIMUM 3 mm RADII, UNLESS OTHERWISE STATED.
  3. TOLERANCE ON SIZE  $\pm 0.5$
  4. THIS PRECAST BLOCK IS SPLITTED IN TO 8 SEGMENTS & WHEN ASSEMBLED TOGETHER SHOULD CONCORD WITH THE OUTER DIMENSIONS.
  5. IDENTIFICATION MARK TO BE PAINTED IN EACH BLOCK.

ITEM NO	DESCRIPTION	DRAWING NO	UNIT WT	QTY
	ROTARY HEARTH FURNACE			
	Bharat Heavy Electrics Ltd SEAMLESS STEEL TUBE PLANT TIRUCHIRAPALLI - 620014			
	SCALE 1:15	WEIGHT (KG) 646		
	DATE	APPROVED		
	REV	ZONE		
TITLE		DRAWING NO :		REV
INNER WALL-AA-55/4-5		2-7-1101-01-01198		00
		U 01		

CAUTION: THE INFORMATION ON THIS DOCUMENT IS THE PROPERTY OF BHARAT HEAVY ELECTRICALS LTD. IT MUST NOT BE USED DIRECTLY OR INDIRECTLY IN ANY MANNER WITHOUT THE WRITTEN PERMISSION OF THE COMPANY.

03

ALL DIMENSIONS ARE IN MM

CAUTION: THE INFORMATION ON THIS DOCUMENT IS THE PROPERTY OF BHARAT HEAVY ELECTRICALS LTD. IT MUST NOT BE USED DIRECTLY OR INDIRECTLY IN ANYWAY DETERMINAL TO INTEREST OF THE COMPANY

REV 01	DATE	ALTERED
		CHECKED
		APPROVED

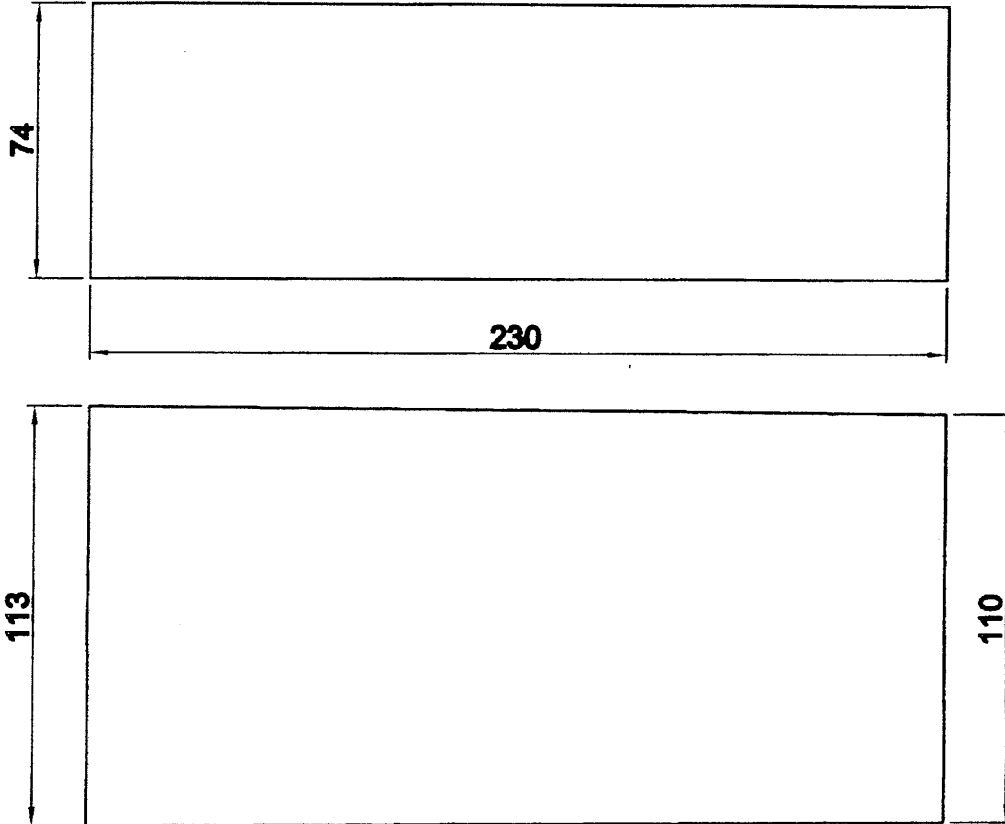



**NOTES:**

- 1) THE REFRACTORIES SHALL BE COMPACT, OF HOMOGENEOUS TEXTURE AND FREE FROM CRACKS, VOIDS AND OTHER FLAWS. THEY SHALL BE BURNT EVENLY THROUGHOUT AND SHALL HAVE SUFFICIENT MECHANICAL STRENGTH AND NO SOFT CORNERS.
- 2) ALL CORNERS TO BE MIN. 5mm RADII.

			55%-60% AL <sub>2</sub> O <sub>3</sub>	6050
ITEM NO	DESCRIPTION	DRAWING NO	MATL CODE	UNIT WT
			MATL SPEC	QTY

EQPT: **ROTARY HEARTH FURNACE**

	Bharat Heavy Electricals Ltd		DRN	NAME	SIGNATURE	DATE
	SEAMLESS STEEL TUBE PLANT		CHD	P. RAMAKRISHNAN	<i>[Signature]</i>	29.12.04
	TIRUCHIRAPALLI - 620014		APPD	SSN.KUMAR	<i>[Signature]</i>	1/1/05
				S.SHANMUGASUNDARAM	<i>[Signature]</i>	01/01/05

DEPT MPG	GRADE OF UNTOL DIM C/M/F		SCALE 1:2	WEIGHT (Kg) 4.8	REF TO ASSY DRG	ITEM NO
CODE					REF TO OLD DRG 358105 1/2-1	

TITLE <b>OUTER WALL SUPPORTING BRICK-I</b>	CARD CODE U 01	DRAWING NO : <b>4-7-1101-01-06301</b>	REV <b>00</b>
---	----------------------	--	------------------

04

CAUTION: THE INFORMATION ON THIS DOCUMENT IS THE PROPERTY OF BHARAT HEAVY ELECTRICALS LTD IT MUST NOT BE USED DIRECTLY OR INDIRECTLY IN ANYWAY DETERMINAL TO INTEREST OF THE COMPANY

ALL DIMENSIONS ARE IN MM

REV	DATE	ALTERED
9		CHECKED
		APPROVED

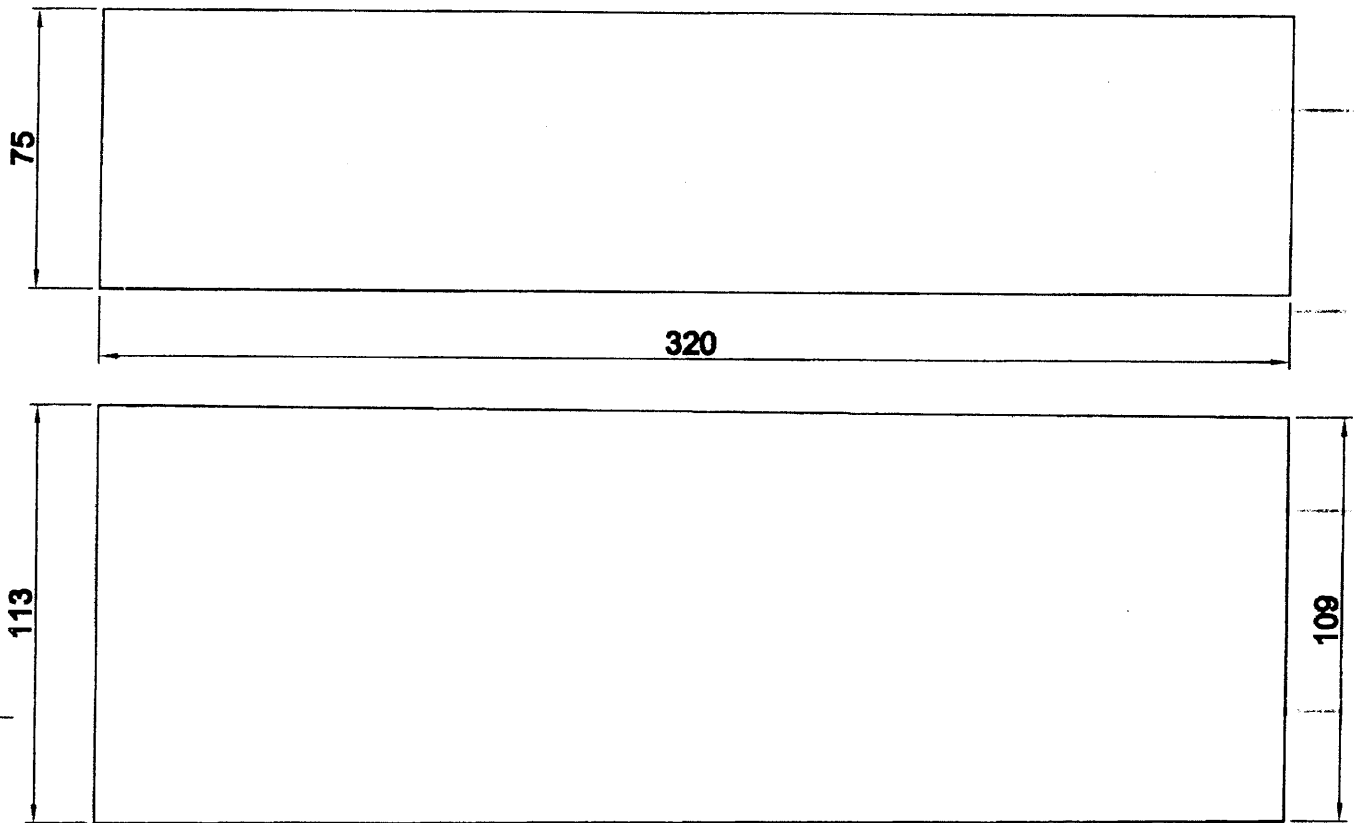

**NOTES:**

- 1) THE REFRACTORIES SHALL BE COMPACT, OF HOMOGENEOUS TEXTURE AND FREE FROM CRACKS, VOIDS AND OTHER FLAWS. THEY SHALL BE BURNT EVENLY THROUGHOUT AND SHALL HAVE SUFFICIENT MECHANICAL STRENGTH AND NO SOFT CORNERS.
- 2) ALL CORNERS TO BE MIN. 5mmRADII.

			55%-60% AL <sub>2</sub> O <sub>3</sub>	1290
ITEM NO	DESCRIPTION	DRAWING NO	MATL CODE	UNIT WT
			MATL SPEC	QTY

EQPT: **ROTARY HEARTH FURNACE**



Bharat Heavy Electricals Ltd  
SEAMLESS STEEL TUBE PLANT  
TIRUCHIRAPALLI - 620014

DRN	NAME P. RAMAKRISHNAN	SIGNATURE	DATE 29.12.04
CHD	SSN.KUMAR	<i>[Signature]</i>	1/1/01
APPD	S.SHANMUGASUNDARAM	<i>[Signature]</i>	01/01/05

DEPT MPG	GRADE OF UNTOL DIM C/M/F		SCALE 1:2	WEIGHT (Kg) 6.7	REF TO ASSY DRG	ITEM NO
CODE					REF TO OLD DRG 358105 1/2-2	

TITLE <b>OUTER WALL SUPPORTING BRICK-II</b>	CARD CODE U 01	DRAWING NO : <b>4-7-1101-01-06302</b>	REV <b>00</b>
--	----------------------	--	------------------

05

ALL DIMENSIONS ARE IN MM

IT MUST NOT BE USED UNLESS IT IS DETERMINED TO BE IN THE INTEREST OF THE COMPANY

REV SI	DATE	ALTERED
		CHECKED
		APPROVED

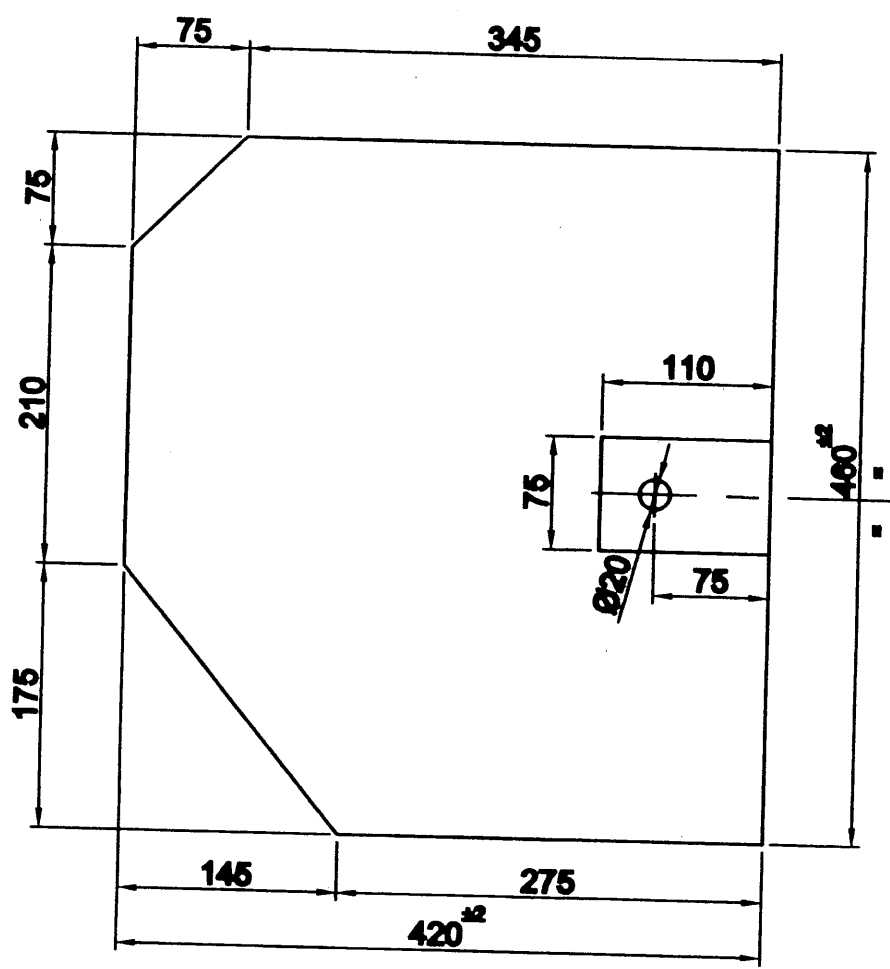

**NOTES:**

- 1) THE REFRACTORIES SHALL BE COMPACT, OF HOMOGENEOUS TEXTURE AND FREE FROM CRACKS, VOIDS AND OTHER FLAWS. THEY SHALL BE BURNT EVENLY THROUGHOUT AND SHALL HAVE SUFFICIENT MECHANICAL STRENGTH AND NO SOFT CORNERS.**
- 2) ALL CORNERS TO BE MIN. 5mmRADII.**

ITEM NO	DESCRIPTION	DRAWING NO	55%-60% AL <sub>2</sub> O <sub>3</sub>	320
			MATL CODE	UNIT WT
			MATL SPEC	QTY

EQPT: <b>ROTARY HEARTH FURNACE</b>				
		<b>Bharat Heavy Electricals Ltd</b> SEAMLESS STEEL TUBE PLANT TIRUCHIRAPALLI - 620014		DRN NAME <b>P. RAMAKRISHNAN</b>
				SIGNATURE <i>[Signature]</i>
				DATE <b>28.12.04</b>
				CHD <b>SANKUMAR</b>
				SIGNATURE <i>[Signature]</i>
				DATE <b>11/1/05</b>
				APPD <b>S.SHANMUGABUNDARAM</b>
				SIGNATURE <i>[Signature]</i>
				DATE <b>01/01/05</b>
DEPT MPG	GRADE OF UNTOL DIM C/M/F	SCALE 1:5	WEIGHT (Kg) 35.5	REF TO ASSY DRG
CODE				REF TO OLD DRG 388105 1/3-5
TITLE <b>INNER WALL SUPPORTING BRICK</b>			CARD CODE U 01	DRAWING NO : <b>4-7-1101-01-06305</b>
				REV <b>00</b>

06

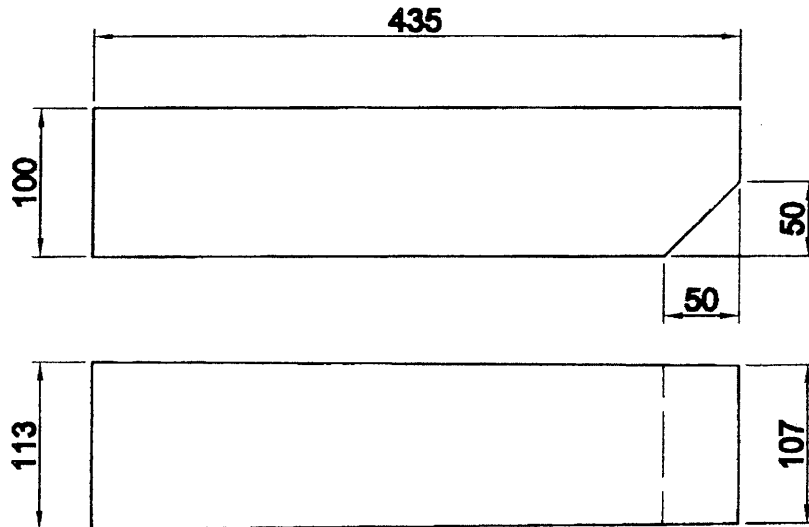

IT MUST NOT BE USED DIRECTLY OR INDIRECTLY IN ANYWAY DETERMINAL TO INTEREST OF THE COMPANY

REV 01	DATE	ALTERED
		CHECKED
		APPROVED



**NOTES:**

- 1) THE REFRACTORIES SHALL BE COMPACT, OF HOMOGENEOUS TEXTURE AND FREE FROM CRACKS, VOIDS AND OTHER FLAWS. THEY SHALL BE BURNT EVENLY THROUGHOUT AND SHALL HAVE SUFFICIENT MECHANICAL STRENGTH AND NO SOFT CORNERS.
- 2) ALL CORNERS TO BE MIN. 5mmRADI.

				55%-60% AL <sub>2</sub> O <sub>3</sub>		460	
ITEM NO	DESCRIPTION	DRAWING NO	MATL CODE		UNIT WT		
			MATL SPEC		QTY		
EQPT: <b>ROTARY HEARTH FURNACE</b>							
 Bharat Heavy Electricals Ltd SEAMLESS STEEL TUBE PLANT TIRUCHIRAPALLI - 620014		DRN	NAME P. RAMAKRISHNAN	SIGNATURE <i>P. Ramakrishnan</i>	DATE 29.12.04		
		CHD	SSN.KUMAR	<i>S. Shanmugasundaram</i>	1/1/05		
		APPD	S.SHANMUGASUNDARAM	<i>S. Shanmugasundaram</i>	01/01/05		
DEPT MPG	GRADE OF UNTOOL DIM C/M/F		SCALE 1:5	WEIGHT (Kg) 12.56	REF TO ASSY DRG		ITEM NO
CODE					REF TO OLD DRG 358105 1/2-6		
TITLE <b>OUTER WALL BASE BRICK-I</b>				CARD CODE U 01	DRAWING NO : <b>4-7-1101-01-06306</b>		REV <b>00</b>

07

ALL DIMENSIONS ARE IN MM

CAUTION: THE INFORMATION ON THIS DOCUMENT IS THE PROPERTY OF BHARAT HEAVY ELECTRICALS LTD IT MUST NOT BE USED DIRECTLY OR INDIRECTLY IN ANYWAY DETERMINANTAL TO INTEREST OF THE COMPANY

REV S1	DATE	ALTERED
		CHECKED
		APPROVED

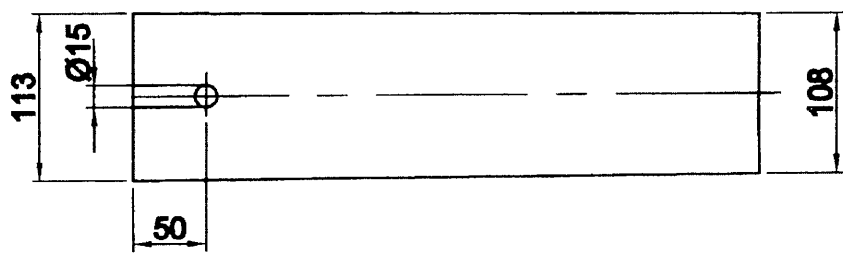
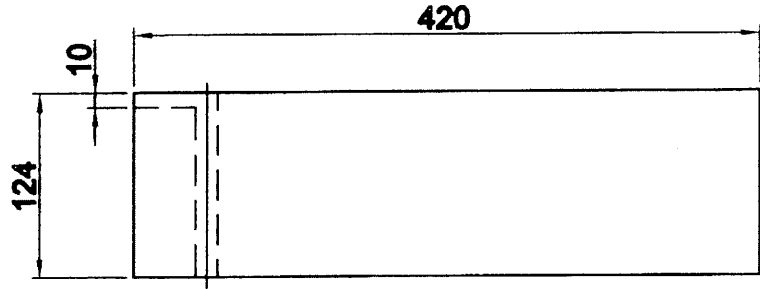

**NOTES:**

- 1) THE REFRACTORIES SHALL BE COMPACT, OF HOMOGENEOUS TEXTURE AND FREE FROM CRACKS, VOIDS AND OTHER FLAWS. THEY SHALL BE BURNT EVENLY THROUGHOUT AND SHALL HAVE SUFFICIENT MECHANICAL STRENGTH AND NO SOFT CORNERS.
- 2) ALL CORNERS TO BE MIN. 5mm RADII.

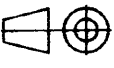
				55%-60% AL <sub>2</sub> O <sub>3</sub>		180
ITEM NO	DESCRIPTION	DRAWING NO	MATL CODE		UNIT WT	
			MATL SPEC		QTY	
EQPT: <b>ROTARY HEARTH FURNACE</b>						
 Bharat Heavy Electricals Ltd SEAMLESS STEEL TUBE PLANT TIRUCHIRAPALLI - 620014		DRN	NAME P. RAMAKRISHNAN	SIGNATURE <i>P. Ramakrishnan</i>	DATE 29.12.04	
		CHD	SSN.KUMAR	<i>S. Shanmugasundaram</i>	1/1/05	
		APPD	S.SHANMUGASUNDARAM	<i>S. Shanmugasundaram</i>	01/01/05	
DEPT MPG	GRADE OF UNTOL DIM C/M/F	SCALE  1:2.5	WEIGHT (Kg) 14.5	REF TO ASSY DRG		ITEM NO
CODE				REF TO OLD DRG 368105 1/2-0		
TITLE OUTER WALL ANCHOR BRICK-II			CARD CODE U 01	DRAWING NO : 4-7-1101-01-06309		REV 00

CAUTION: THE INFORMATION ON THIS DOCUMENT IS THE PROPERTY OF BHARAT HEAVY ELECTRICALS LTD. IT MUST NOT BE USED DIRECTLY OR INDIRECTLY IN ANYWAY DETERMINANTAL TO INTEREST OF THE COMPANY.

ALL DIMENSIONS ARE IN MM

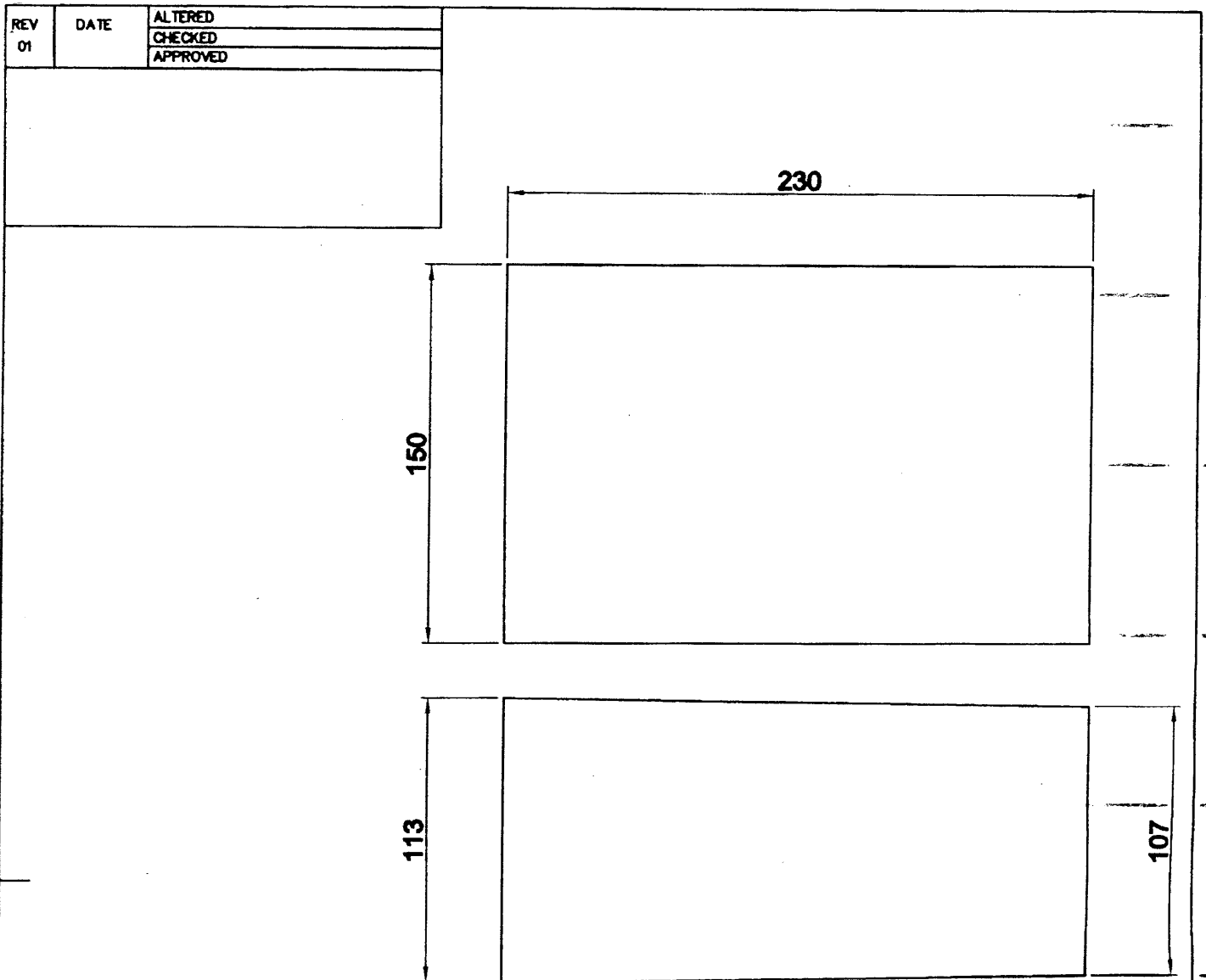

**NOTES:**

- 1) THE REFRACTORIES SHALL BE COMPACT, OF HOMOGENEOUS TEXTURE AND FREE FROM CRACKS, VOIDS AND OTHER FLAWS. THEY SHALL BE BURNT EVENLY THROUGHOUT AND SHALL HAVE SUFFICIENT MECHANICAL STRENGTH AND NO SOFT CORNERS.
- 2) ALL CORNERS TO BE MIN. 5mm RADII.

			55%-60% AL <sub>2</sub> O <sub>3</sub>	220
ITEM NO	DESCRIPTION	DRAWING NO	MATL CODE	UNIT-WT
			MATL SPEC	QTY

EQPT: **ROTARY HEARTH FURNACE**

	<b>Bharat Heavy Electricals Ltd</b> SEAMLESS STEEL TUBE PLANT TIRUCHIRAPALLI - 620014	DRN	NAME <b>P. RAMAKRISHNAN</b>	SIGNATURE <i>P. Ramakrishnan</i>	DATE <b>29.12.04</b>
		CHD	<b>SSN.KUMAR</b>	<i>SSN.Kumar</i>	<b>1/1/05</b>
		APPD	<b>S.SHANMUGASUNDARAM</b>	<i>S. Shanmugasundaram</i>	<b>01/01/05</b>

DEPT <b>MPG</b>	GRADE OF UNTOL DIM C/M/F		SCALE <b>1:2.5</b>	WEIGHT (Kg) <b>9.5</b>	REF TO ASSY DRG	ITEM NO
CODE					REF TO OLD DRG <b>358106 1/2-12</b>	

TITLE <b>INNER WALL SHAPE BRICK-I</b>	CARD CODE <b>U 01</b>	DRAWING NO : <b>4-7-1101-01-06312</b>	REV <b>00</b>
--	-----------------------------	--	------------------

ALL DIMENSIONS ARE IN MM

CAUTION: THE INFORMATION ON THIS DOCUMENT IS THE PROPERTY OF BHARAT HEAVY ELECTRICALS LTD  
IT MUST NOT BE USED DIRECTLY OR INDIRECTLY IN ANYWAY DETERMINAL TO INTEREST OF THE COMPANY

REV	DATE	ALTERED
		CHECKED
		APPROVED

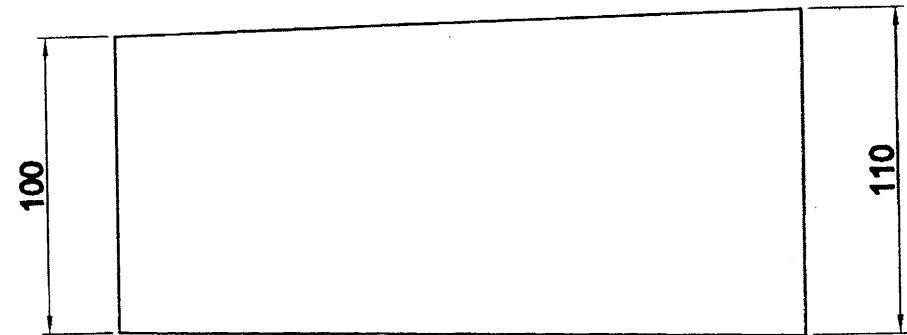
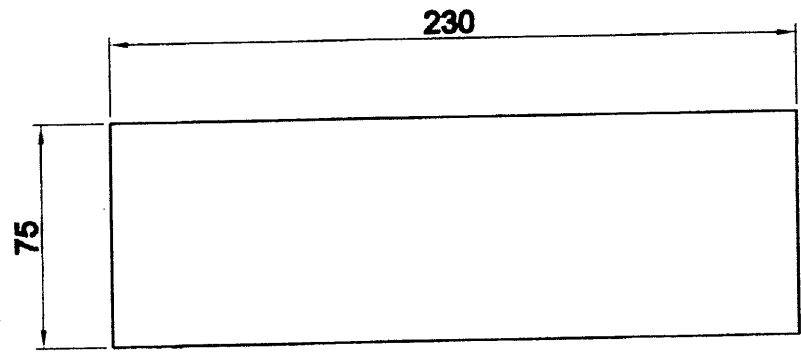

**NOTES:**

- 1) THE REFRACTORIES SHALL BE COMPACT, OF HOMOGENEOUS TEXTURE AND FREE FROM CRACKS, VOIDS AND OTHER FLAWS. THEY SHALL BE BURNT EVENLY THROUGHOUT AND SHALL HAVE SUFFICIENT MECHANICAL STRENGTH AND NO SOFT CORNERS.
- 2) ALL CORNERS TO BE MIN. 5mmRADII.

ITEM NO	DESCRIPTION	DRAWING NO	55%-60% AL <sub>2</sub> O <sub>3</sub>	575
			MATL CODE	UNIT-WT
			MATL SPEC	QTY

EQPT: **ROTARY HEARTH FURNACE**

	Bharat Heavy Electricals Ltd SEAMLESS STEEL TUBE PLANT TRUCHIRAPALLI - 620014	DRN	NAME P. RAMAKRISHNAN	SIGNATURE <i>[Signature]</i>	DATE 29.12.04
		CHD	SSN.KUMAR	<i>[Signature]</i>	01/1/05
		APPD	B.SHANMUGASUNDARAM	<i>[Signature]</i>	01/01/05

DEPT MPG	GRADE OF UNTOL DIM C/M/F	SCALE 1:2.5	WEIGHT (Kg) 4.5	REF TO ASSY DRG	ITEM NO
CODE				REF TO OLD DRG 368105 1/2-13	

TITLE <b>INNER WALL SHAPE BRICK-II</b>	CARD CODE U 01	DRAWING NO : <b>4-7-1101-01-06313</b>	REV <b>00</b>
---	----------------------	--	------------------

ALL DIMENSIONS ARE IN MM

CAUTION: THE INFORMATION ON THIS DOCUMENT IS THE PROPERTY OF BHARAT HEAVY ELECTRICALS LTD. IT MUST NOT BE USED DIRECTLY OR INDIRECTLY IN ANY MANNER TERMINAL TO INTEREST OF THE COMPANY.

REV OF	DATE	ALTERED
		CHECKED
		APPROVED

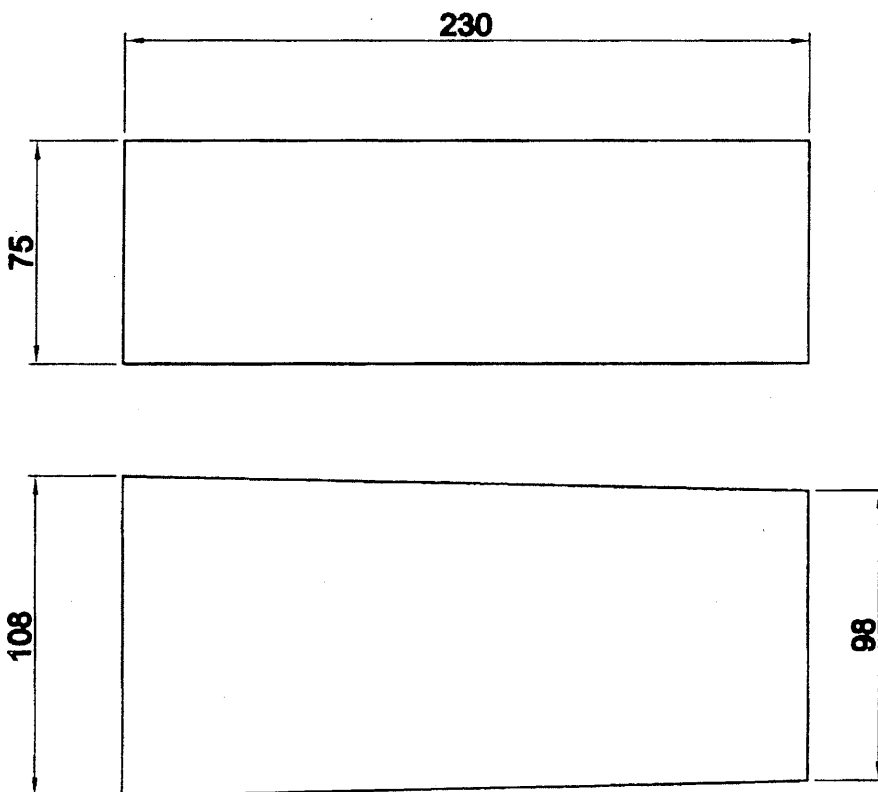

**NOTES:**

- 1) THE REFRACTORIES SHALL BE COMPACT, OF HOMOGENEOUS TEXTURE AND FREE FROM CRACKS, VOIDS AND OTHER FLAWS. THEY SHALL BE BURNT EVENLY THROUGHOUT AND SHALL HAVE SUFFICIENT MECHANICAL STRENGTH AND NO SOFT CORNERS.
- 2) ALL CORNERS TO BE MIN. 5mmRADI.

			55%-60% AL <sub>2</sub> O <sub>3</sub>	2850
ITEM NO	DESCRIPTION	DRAWING NO	MATL CODE	UNIT WT
			MATL SPEC	QTY

EQPT: **ROTARY HEARTH FURNACE**



Bharat Heavy Electricals Ltd  
SEAMLESS STEEL TUBE PLANT  
TIRUCHIRAPALLI - 620014

DRN	NAME P. RAMAKRISHNAN	SIGNATURE	DATE 29.12.04
CHD	SSNKUMAR	SIGNATURE	DATE 1/1/05
APPD	S.SHANMUGASUNDARAM	SIGNATURE	DATE 01/01/05

DEPT MPG	GRADE OF UNTOL DIM C/M/F		SCALE 1:2.5	WEIGHT (Kg) 4.4	REF TO ASSY DRG	ITEM NO
CODE					REF TO OLD DRG 358105 1/2-15	

TITLE <b>INNER WALL SHAPE BRICK-IV</b>	CARD CODE U 01	DRAWING NO : <b>4-7-1101-01-06315</b>	REV <b>00</b>
---	----------------------	--	------------------

CAUTION: THE INFORMATION ON THIS DOCUMENT IS THE PROPERTY OF BHARAT HEAVY ELECTRICALS LTD  
IT MUST NOT BE USED DIRECTLY OR INDIRECTLY IN ANYWAY DETERMINAL TO INTEREST OF THE COMPANY

REV 9	DATE	ALTERED
		CHECKED
		APPROVED

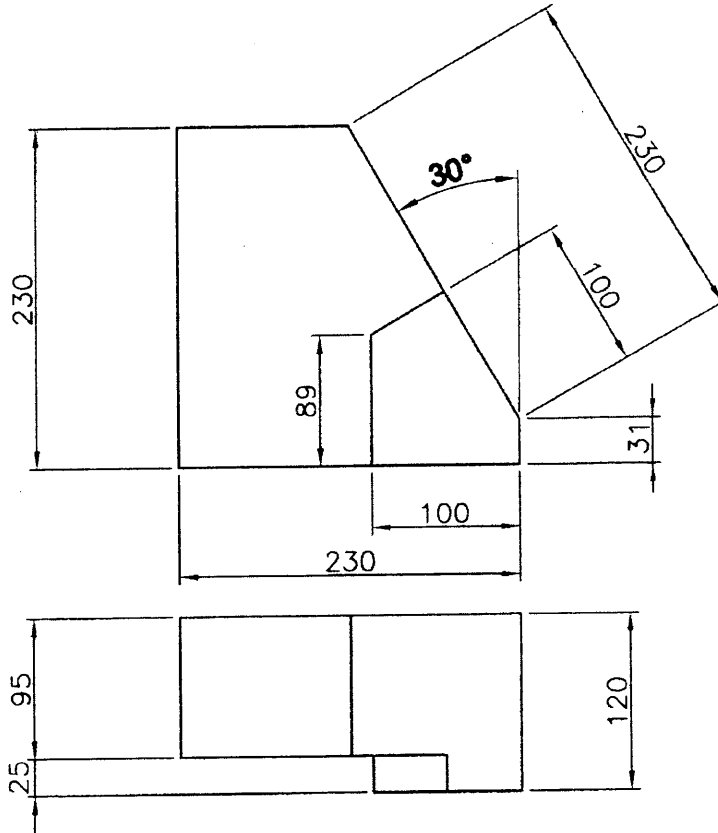



**NOTES:**

- 1. THE REFRACTORIES SHALL BE COMPACT, OF HOMOGENEOUS TEXTURE AND FREE FROM CRACKS, VOIDS AND OTHER FLAWS, THEY SHALL BE BURNT EVENLY THROUGHOUT, AND SHALL HAVE SUFFICIENT MECHANICAL STRENGTH AND NO SOFT CORNERS.**
- 2. ALL CORNERS TO BE MINIMUM 3 mm.RADII, UNLESS OTHERWISE STATED.**
- 3. TOLERANCE ON SIZE  $\begin{matrix} +0 \\ -1 \end{matrix}$**

ITEM NO	DESCRIPTION	DRAWING NO	55-60% AL <sub>2</sub> O <sub>3</sub>	2
			MATL CODE	UNIT WT
			MATL SPEC	QTY

EQPT: **ROTARY HEARTH FURNACE**

 Bharat Heavy Electricals Ltd SEAMLESS STEEL TUBE PLANT TIRUCHIRAPALLI - 620014	DRN	NAME <b>SSN.KUMAR</b>	SIGNATURE <i>SSN.Kumar</i>	DATE <b>15.12.04</b>
	CHD			
	APPD	<b>S.SHANMUGASUNDARAM</b>	<i>S. Shanmugasundaram</i>	<b>16/12/04</b>

DEPT MPG	GRADE OF UNTOL DIM ϕ/M/f		SCALE <b>1:5</b>	WEIGHT (Kg) <b>10</b>	REF TO ASSY DRG	ITEM NO
CODE					REF TO OLD DRG <b>FA-0427-3/8</b>	

TITLE <b>SKEW BACK-R.H CHARGING &amp; DISCHARGING DOORS</b>	CARD CODE <b>U 01</b>	DRAWING NO : <b>4-7-1101-01-06284</b>	REV <b>00</b>
--	--------------------------	--	------------------

CAUTION: THE INFORMATION ON THIS DOCUMENT IS THE PROPERTY OF BHARAT HEAVY ELECTRICALS LTD  
IT MUST NOT BE USED DIRECTLY OR INDIRECTLY IN ANYWAY DETERMINAL TO INTEREST OF THE COMPANY

ALL DIMENSIONS ARE IN MM

REV 01	DATE	ALTERED
		CHECKED
		APPROVED

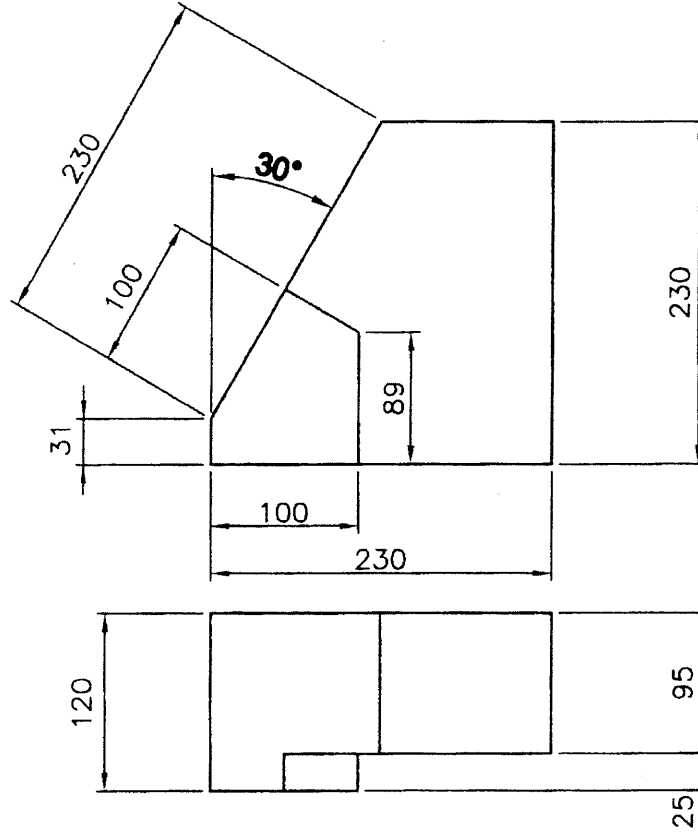

**NOTES:**

- 1. THE REFRACTORIES SHALL BE COMPACT, OF HOMOGENEOUS TEXTURE AND FREE FROM CRACKS, VOIDS AND OTHER FLAWS, THEY SHALL BE BURNT EVENLY THROUGHOUT, AND SHALL HAVE SUFFICIENT MECHANICAL STRENGTH AND NO SOFT CORNERS.**
- 2. ALL CORNERS TO BE MINIMUM 3 mm.RADII, UNLESS OTHERWISE STATED.**
- 3. TOLERANCE ON SIZE  $\begin{matrix} +0 \\ -1 \end{matrix}$**

			55-60% $AL_2O_3$	2
ITEM NO	DESCRIPTION	DRAWING NO	MATL CODE	UNIT WT
			MATL SPEC	QTY

EQPT: **ROTARY HEARTH FURNACE**



Bharat Heavy Electricals Ltd  
SEAMLESS STEEL TUBE PLANT  
TIRUCHIRAPALLI - 620014

DRN	NAME SSN.KUMAR	SIGNATURE <i>SSN.Kumar</i>	DATE 15.12.04
CHD			
APPD	S.SHANMUGASUNDARAM	<i>S. Shanmugasundaram</i>	16/12/04

DEPT MPG	GRADE OF UNTOL. DIM G/M/F		SCALE 1:5	WEIGHT (Kg) 10	REF TO ASSY DRG	ITEM NO
CODE					REF TO OLD DRG FA-0427-3/9	

TITLE <b>SKEW BACK-L.H CHARGING &amp; DISCHARGING DOORS</b>	CARD CODE U 01	DRAWING NO : <b>4-7-1101-01-06285</b>	REV <b>00</b>
--	----------------------	--	------------------

S 27-009

FIRST ANGLE PROJECTION (ALL DIMENSIONS IN MILLIMETRES)

CAUTION THE INFORMATION ON THIS DOCUMENT IS THE PROPERTY OF BHARAT HEAVY ELECTRICALS LTD. IT MUST NOT BE USED DIRECTLY OR INDIRECTLY IN ANY WAY DETRIMENTAL TO THE INTEREST OF THE COMPANY.

REV 01	DATE	ALTERED
	31-12-01	CHECKED
ZONE		APPROVED
MATL SPEC REVISED AS PER NESMAN REVISION		

P  
→

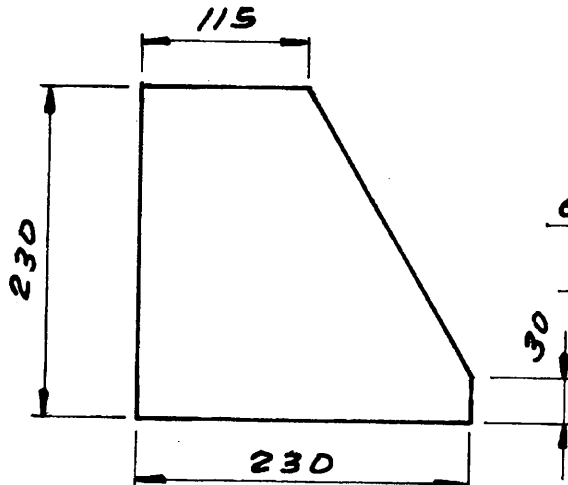
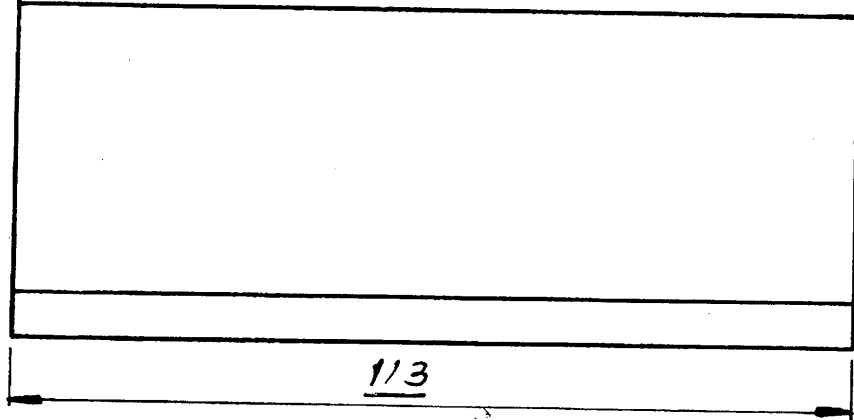

QUALITY:-

55-60% AL2O3

SILLIMANITE.

ITEM NO.	DESCRIPTION	MATL CODE	UNIT WT
		MATL SPEC	QTY

EQPT: RHF



**Bharat Heavy Electricals Ltd.,**  
SEAMLESS STEEL TUBE PLANT  
TIRUCHIRAPALLI - 620 014

DRN	NAME	DATE
	SEN-KUMAR	10.7.91
CHD		11.7.91
APPD		1.11.94

DEPT CODE	GRADE OF UNTOOL DIM C/M/F	WEIGHT (kg)	REF TO ASSY/OLD DRG	ITEM NO.
		1:5	4-1101-58-48*	

TITLE	CARD CODE	DRAWING NO.	REV
<b>SKEW BACK</b>	U 01	4-7-1101-01-0445701	

12

ALL DIMENSIONS ARE IN MM

CAUTION: THE INFORMATION ON THIS DOCUMENT IS THE PROPERTY OF BHARAT HEAVY ELECTRICALS LTD IT MUST NOT BE USED DIRECTLY OR INDIRECTLY IN ANYWAY DETERMINAL TO INTEREST OF THE COMPANY

REV 01	DATE	ALTERED
		CHECKED
		APPROVED

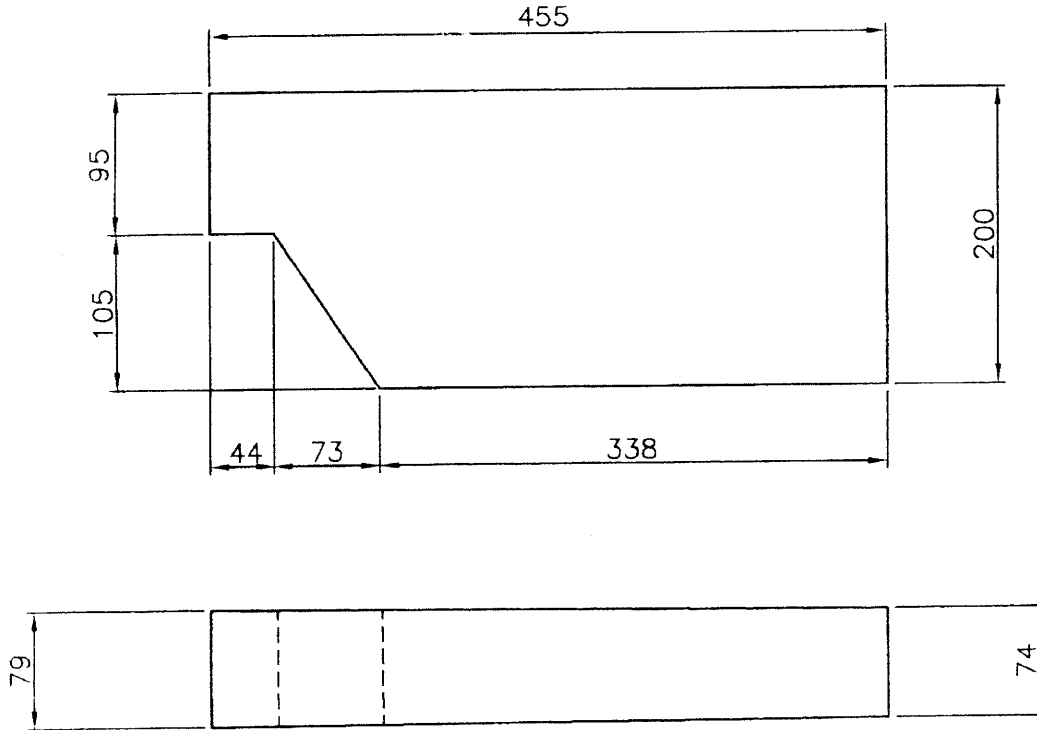

**NOTES:**

1. THE REFRACTORIES SHALL BE COMPACT, OF HOMOGENEOUS TEXTURE AND FREE FROM CRACKS, VOIDS AND OTHER FLAWS, THEY SHALL BE BURNT EVENLY THROUGHOUT, AND SHALL HAVE SUFFICIENT MECHANICAL STRENGTH AND NO SOFT CORNERS.
2. ALL CORNERS TO BE MINIMUM 3 mm. RADII, UNLESS OTHERWISE STATED.
3. TOLERANCE ON SIZE  $\begin{matrix} +0 \\ -1 \end{matrix}$

				80% AL <sub>2</sub> O <sub>3</sub>	600
ITEM NO	DESCRIPTION	DRAWING NO		MATL CODE	UNIT WT
				MATL SPEC	QTY
EQPT: <b>ROTARY HEARTH FURNACE</b>					
 Bharat Heavy Electricals Ltd SEAMLESS STEEL TUBE PLANT TIRUCHIRAPALLI - 620014		DRN	NAME <b>SSN.KUMAR</b>	SIGNATURE <i>S.S.N. Kumar</i>	DATE <b>15.12.04</b>
		CHD			
		APPD	<b>S.SHANMUGASUNDARAM</b>	<i>S. Shanmugasundaram</i>	<b>16/12/04</b>
DEPT <b>MPG</b>	GRADE OF UNTOL. DIM $\phi/M/f$	SCALE <b>1:5</b>	WEIGHT (Kg) <b>17.6</b>	REF TO ASSY DRG	ITEM NO
CODE				REF TO OLD DRG <b>FA-0427-3/2</b>	
TITLE <b>HEARTH TOP OUTER SLAB BLOCK</b>			CARD CODE <b>U 01</b>	DRAWING NO : <b>4-7-1101-01-06278</b>	REV <b>00</b>

18

ALL DIMENSIONS ARE IN MM

CAUTION: THE INFORMATION ON THIS DOCUMENT IS THE PROPERTY OF BHARAT HEAVY ELECTRICALS LTD  
IT MUST NOT BE USED DIRECTLY OR INDIRECTLY IN ANYWAY DETERMINAL TO INTEREST OF THE COMPANY

REV 01	DATE	ALTERED
		CHECKED
		APPROVED

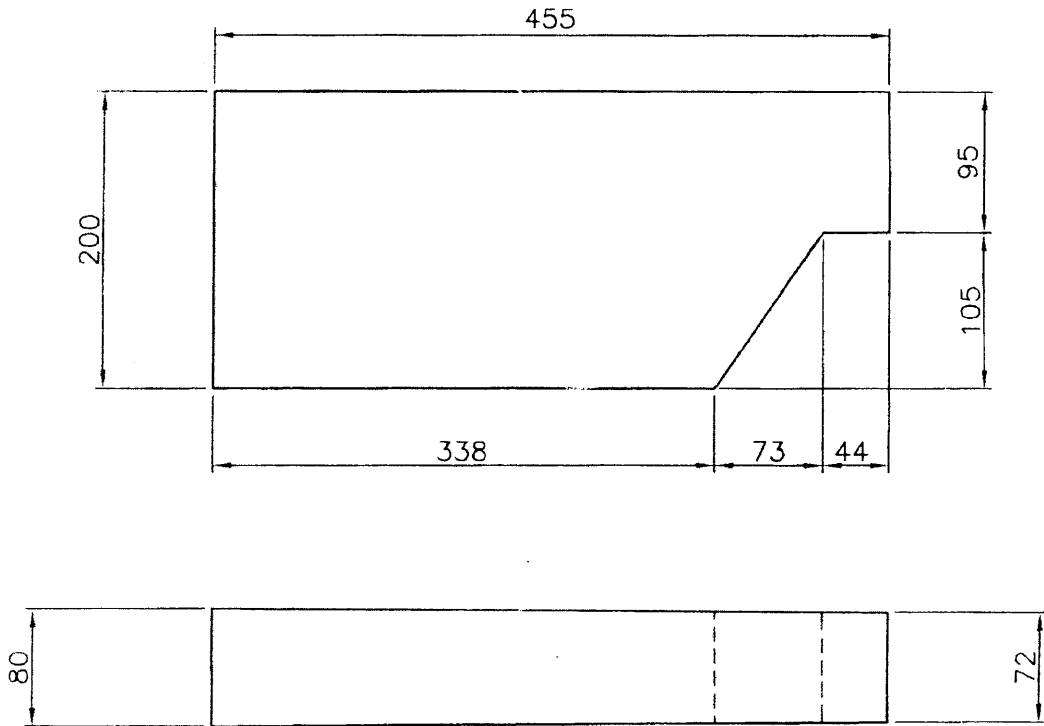



**NOTES:**

1. THE REFRACTORIES SHALL BE COMPACT, OF HOMOGENEOUS TEXTURE AND FREE FROM CRACKS, VOIDS AND OTHER FLAWS, THEY SHALL BE BURNT EVENLY THROUGHOUT, AND SHALL HAVE SUFFICIENT MECHANICAL STRENGTH AND NO SOFT CORNERS.
2. ALL CORNERS TO BE MINIMUM 3 mm. RADII, UNLESS OTHERWISE STATED.
3. TOLERANCE ON SIZE  $\pm 0.1$

ITEM NO	DESCRIPTION	DRAWING NO	80% AL <sub>2</sub> O <sub>3</sub>	360
			MATL CODE	UNIT WT
			MATL SPEC	QTY

EQPT: **ROTARY HEARTH FURNACE**

	Bharat Heavy Electricals Ltd SEAMLESS STEEL TUBE PLANT TIRUCHIRAPALLI - 620014		DRN	NAME SSN.KUMAR	SIGNATURE <i>S.S.N. Kumar</i>	DATE 15.12.04
			CHD			
			APPD	B.SHANMUGASUNDARAM	<i>S. Shanmugasundaram</i>	16/12/04
DEPT MPG	GRADE OF UNTOL DIM ø/M/F		SCALE 1:5	WEIGHT (Kg) 17.4	REF TO ASSY DRG	ITEM NO
CODE					REF TO OLD DRG FA-0427-3/3	
TITLE HEARTH TOP INNER SLAB BLOCK			CARD CODE U 01	DRAWING NO : 4-7-1101-01-06279		REV 00

FIRST ANGLE PROJECTION (ALL DIMENSIONS IN MILLIMETRES)

REV 01	DATE	ALTERED	REV 02	DATE	ALTERED
		CHECKED			CHECKED

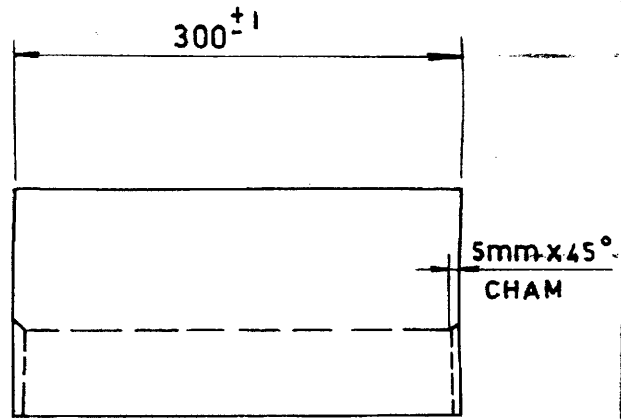
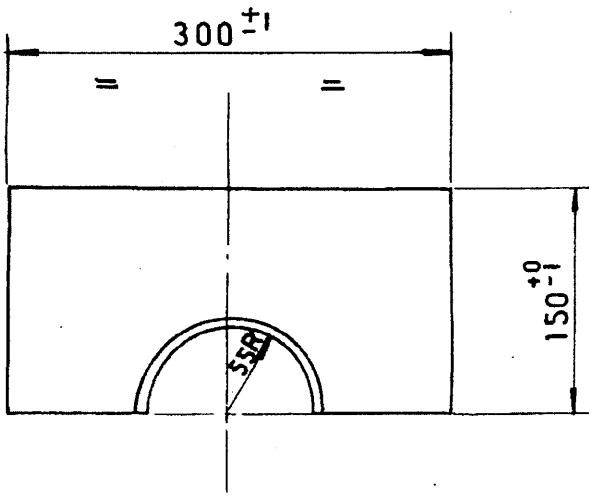

**NOTES**

1. THE REFRACTORIES SHALL BE COMPACT OF HOMOGENEOUS TEXTURE AND FREE FROM CRACKS, VOIDS AND OTHER FLAWS. THEY SHALL BE BURNT EVENLY THROUGH OUT, AND SHALL HAVE SUFFICIENT MECHANICAL STRENGTH AND NO SOFT CORNERS.
2. ALL CORNERS TO BE MIN. 3m.m. RADII.

6					24
		IS - 8			28
PART No.	DESCRIPTION	MATL CODE	A	UNIT	UNIT WT
		MATL SPEC	C		QTY

EQPT: ROLL DOWN FURNACE

		<b>Bharat Heavy Electricals Ltd.,</b> SEAMLESS STEEL TUBE PLANT TIRUCHIRAPALLI-620 014		DRN	NAME	SIGN	DATE
DEPT.		GRADE OF UNTOL. DIM	SCALE	672	A. PALANI	[Signature]	29/10/94
CODE		C/M/F	1:5		A. MOCKIAM	[Signature]	29.10.94
TITLE		ROLL BLOCK		WEIGHT (kg)	APPD	[Signature]	01/11/94
					REF TO ASSY / LD DRG		ITEM NO.
					D-12-A 4-1145-08-911		
				CARD CODE	DRAWING NO.		REV
				U 01	4-7.1145-01-04485		00

CAUTION THE INFORMATION ON THIS DOCUMENT IS THE PROPERTY OF BHARAT HEAVY ELECTRICALS LTD. IT MUST NOT BE USED DIRECTLY OR INDIRECTLY IN ANY WAY DETRIMENTAL TO THE INTEREST OF THE COMPANY

95-249/B

CAUTION: THE INFORMATION ON THIS DOCUMENT IS THE PROPERTY OF BHARAT HEAVY ELECTRICALS LTD IT MUST NOT BE USED DIRECTLY OR INDIRECTLY IN ANYWAY DETERMINANT TO INTEREST OF THE COMPANY

ALL DIMENSIONS ARE IN MM

REV	DATE	ALTERED
01		CHECKED
		APPROVED

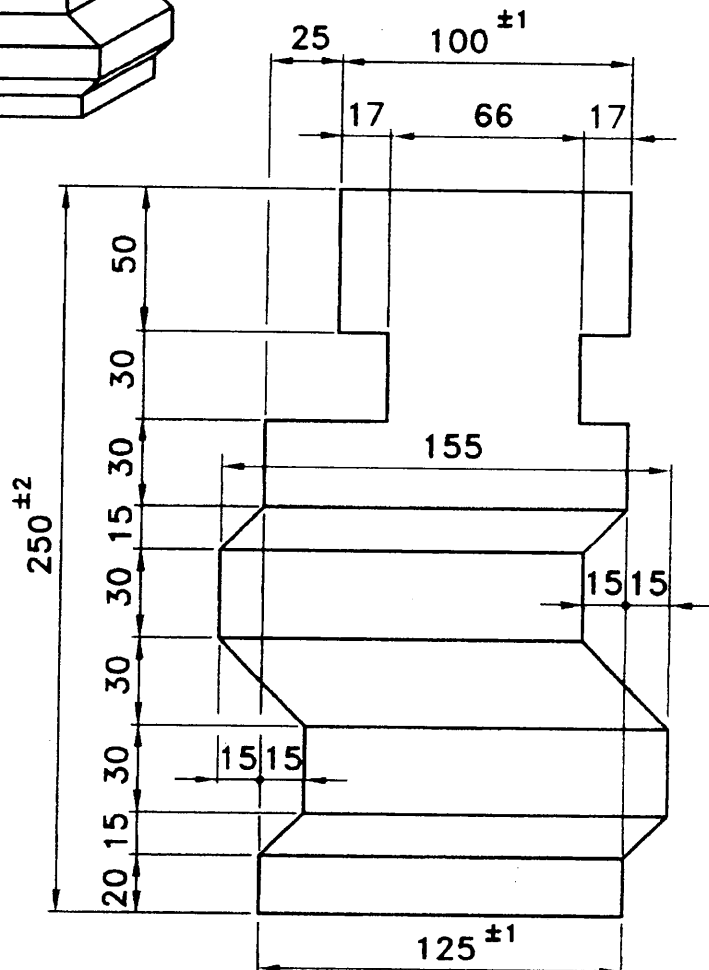
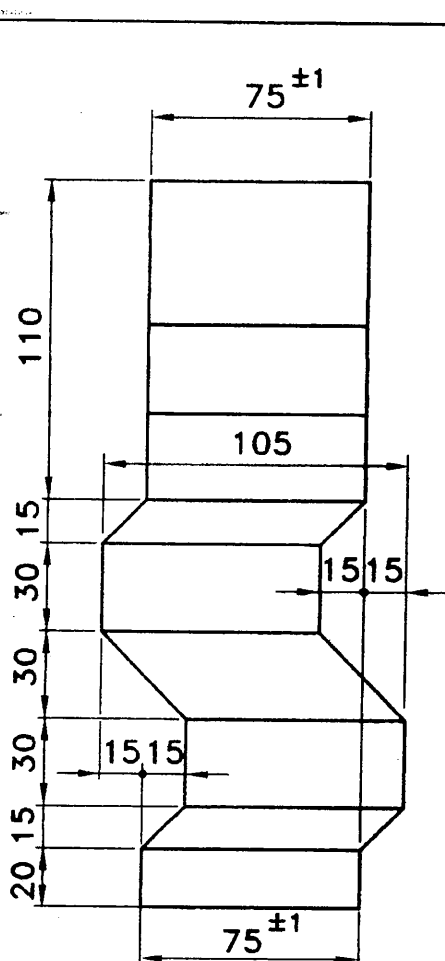
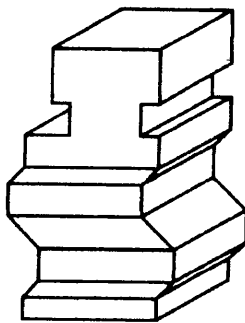

**NOTE:**

THE REFRACTORIES SHALL BE COMPACT OF HOMOGENOUS TEXTURE AND FREE FROM CRACKS VOIDS AND OTHER FLAWS THEY SHALL BE BURNT EVENLY THROUGHOUT AND SHALL HAVE SUFFICIENT MECHANICAL STRENGTH AND NO SOFT CORNERS.

ITEM NO	DESCRIPTION	DRAWING NO	5.100
			54% AL2 O3
			MATL CODE
			MATL SPEC
			UNIT WT
			QTY

EQPT: ROTARY HEARTH FURNACE



Bharat Heavy Electricals Ltd  
SEAMLESS STEEL TUBE PLANT  
TIRUCHIRAPALLI - 620014

DRN	NAME	SIGNATURE	DATE
	S.MOHAN RAJ	<i>S. Mohan Raj</i>	27.02.99
CHD	A.AROCKIAM	<i>A. Arockiam</i>	1.3.99
APPD	S.SHANMUGASUNDARAM	<i>S. Shanmugasundaram</i>	01.03.99

DEPT	GRADE OF UNTOL DIM	SCALE	WEIGHT (Kg)	REF TO ASSY DRG	ITEM NO
MPG	C/M/F	1:2.5	5.100	REF TO OLD DRG 4-1101-01-54-280	

TITLE	CARD CODE	DRAWING NO :	REV
ROOF BRICK -H29 (LARGE)	U 01	4-7-1101-01-04450	00

21

CAUTION: THE INFORMATION ON THIS DOCUMENT IS THE PROPERTY OF BHARAT HEAVY ELECTRICALS LTD IT MUST NOT BE USED DIRECTLY OR INDIRECTLY IN ANYWAY DETERMINANTAL TO INTEREST OF THE COMPANY

ALL DIMENSIONS ARE IN MM

REV	DATE	ALTERED
9		CHECKED
		APPROVED

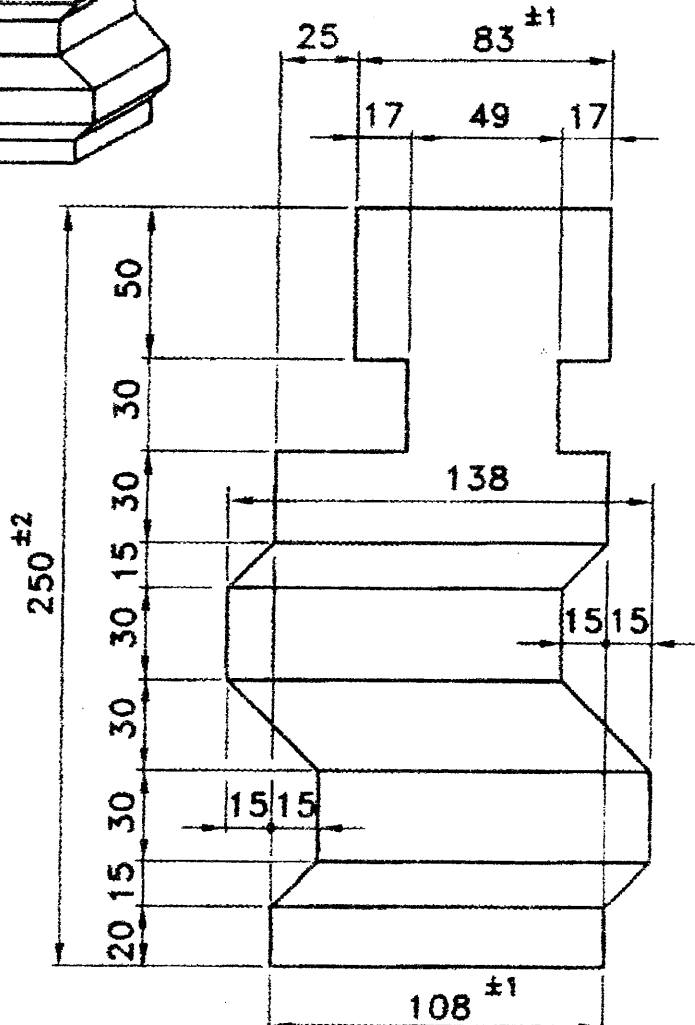
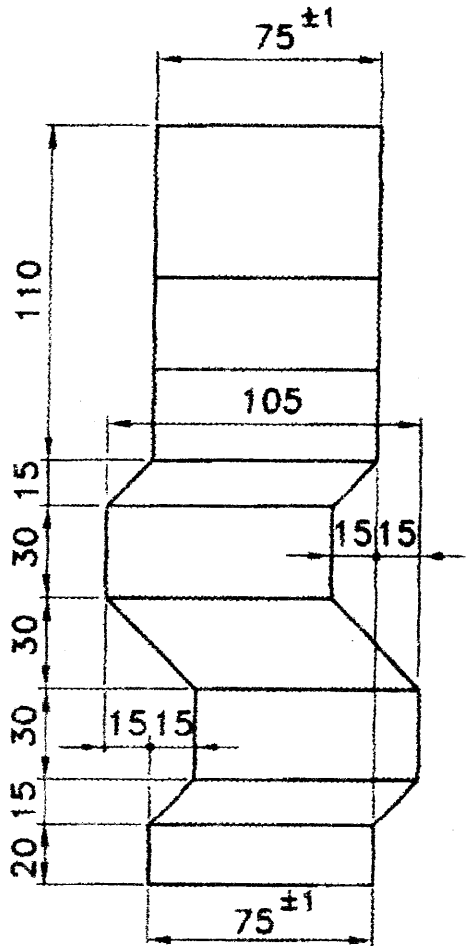
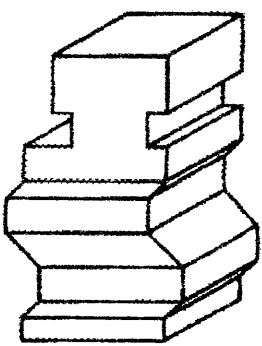

**NOTE:**  
THE REFRACTORIES SHALL BE COMPACT OF HOMOGENOUS TEXTURE AND FREE FROM CRACKS  
VOIDS AND OTHER FLAWS THEY SHALL BE BURNT EVENLY THROUGHOUT AND SHALL HAVE  
SUFFICIENT MECHANICAL STRENGTH AND NO SOFT CORNERS

ITEM NO	DESCRIPTION	DRAWING NO	MATL CODE	UNIT WT
			54% AL2 O3	4.300
			MATL SPEC	QTY

EQPT: ROTARY HEARTH FURNACE

	Bharat Heavy Electricals Ltd		DRN	NAME	SIGNATURE	DATE
	SEAMLESS STEEL TUBE PLANT		CHKD	S. MOHAN RAJ	<i>S. Mohan Raj</i>	27.02.99
	TRUCHIRAPALLI - 620014		APTD	A. AROCKIAN	<i>A. Arockian</i>	1-3-99
				S. SHANMUGASUNDARAM	<i>S. Shanmugasundaram</i>	10-3-99

DEPT	MPG	GRADE OF UNITS DIM	SCALE	WEIGHT (Kg)	REF TO ASSY DRG	ITEM NO
CODE		C/M/F	1:2.5	4.300	REF TO OLD DRG	
					4-1101-01-54-344	

TITLE	CARD CODE	DRAWING NO :	REV
ROOF BRICK -H30 (SMALL)	U 01	4-7-1101-01-04455	00

ALL DIMENSIONS ARE IN MILLIMETERS

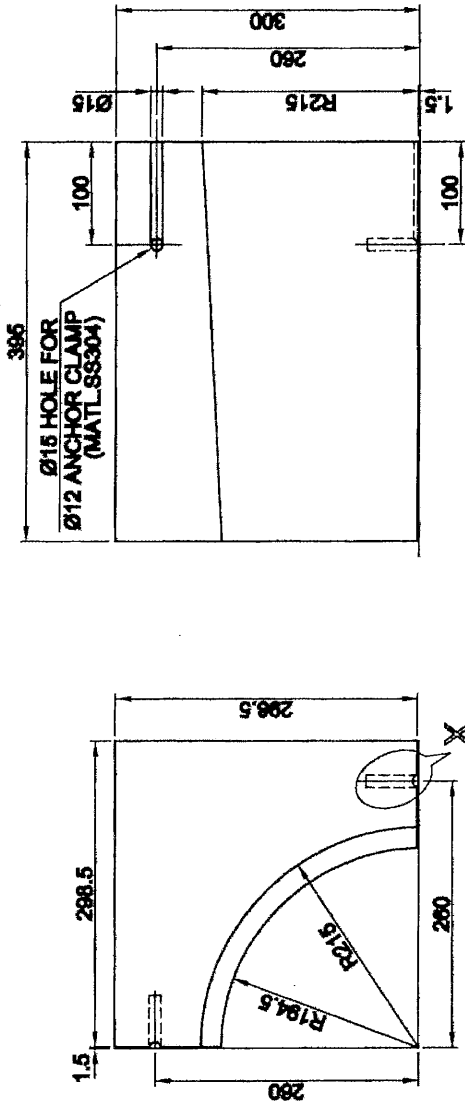

DETAIL OF ONE SEGMENT

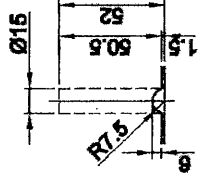

DETAIL-X

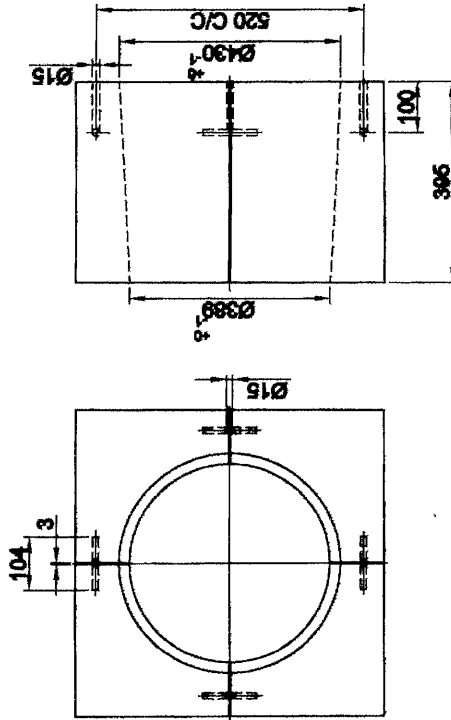

NOTES:

1. THE REFRACTORIES SHALL BE COMPACT, OF HOMOGENEOUS TEXTURE AND FREE FROM CRACKS, VOIDS AND OTHER FLAWS, THEY SHALL BE BURNT EVENLY THROUGHOUT, AND SHALL HAVE SUFFICIENT MECHANICAL STRENGTH AND NO SOFT CORNERS.
2. ALL CORNERS TO BE MIN. 3mm RADII.
3. TOLERANCE ON SIZE  $\pm 1\%$  OR  $\pm 1\text{mm}$  WHICHEVER IS GREATER.

ITEM NO	DESCRIPTION	DRAWING NO	80% AL <sub>2</sub> O <sub>3</sub>	UNIT WT	18
EQPT: WALKING BEAM FURNACE			MATL CODE	MATL SPEC	QTY
Bharat Heavy Electricals Ltd SEAMLESS STEEL TUBE PLANT TRUCHIRAPALLI - 620014		DIN	NAME	SIGNATURE	DATE
DEPT: MPG CODE: C/A/F		CHD	SKULKUMAR	JAY. K.	17.12.04
SCALE: 1:5 		APPD	SHANMUGASUNDARAM		24/12/04
WEIGHT(Kg) 218		REF TO ASST DWG NO	REF TO OLD DWG NO	FA-0428-1	
TITLE: ROLLER BLOCK GUARD		CARD CODE	DRAWING NO :	3-7-1150-01-04705	REV
U 01					00

ALL DIMENSIONS ARE IN MILLIMETERS

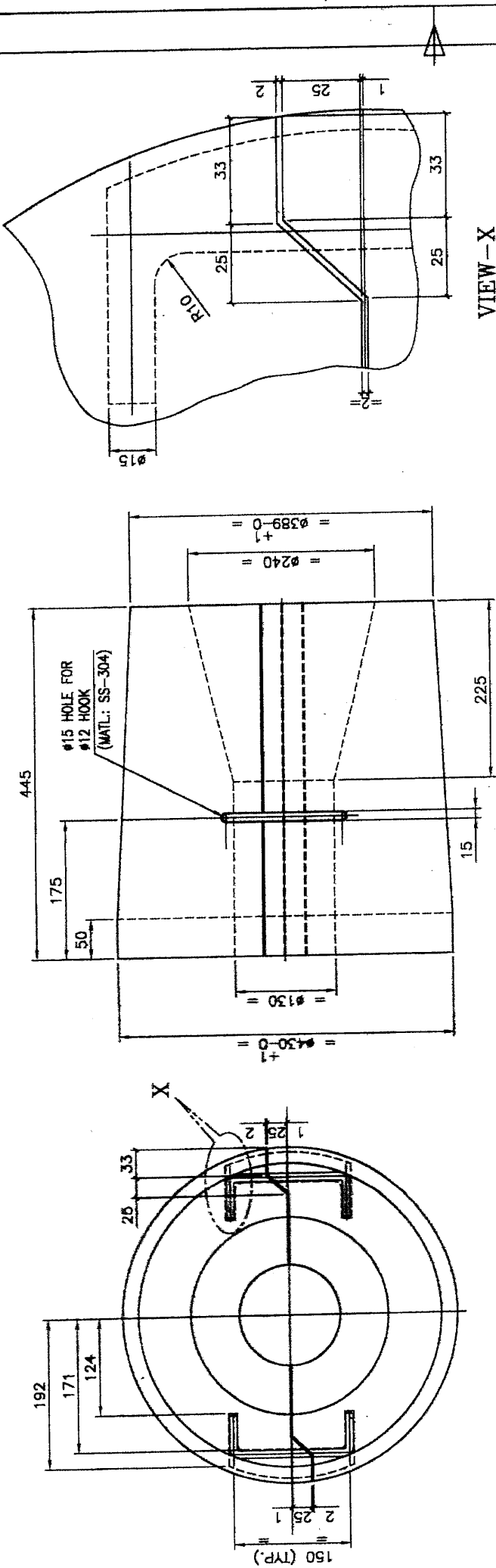

VIEW-X

**NOTES:**

1. THE REFRACTORIES SHALL BE COMPACT, OF HOMOGENEOUS TEXTURE AND FREE FROM CRACKS, Voids AND OTHER FLAWS, THEY SHALL BE BURNT EVENLY THROUGHOUT, AND SHALL HAVE SUFFICIENT MECHANICAL STRENGTH AND NO SOFT CORNERS.
2. ALL CORNERS TO BE MIN. 3mm RADIUS.
3. TOLERANCE ON SIZE  $\pm 1\%$  OR  $\pm 1\text{mm}$  WHICHEVER IS GREATER.

ITEM NO	DESCRIPTION	DRAWING NO	UNIT WT	QTY
				8
EQUIP: WALKING BEAM FURNACE				
Bharat Heavy Electricids Ltd SEAMLESS STEEL TUBE PLANT TIRUCHIRAPALLI - 620014				
DEPT	MPG CODE	SCALE	VERSION	DATE
		1:5	126	17/12/04
NAME	SIGNATURE	DATE		
		17/12/04		
REF TO OLD Dwg NO	FA-0428-1	DRAWING NO :		
REF TO NEW Dwg NO		3-7-1150-01-04706 00		
REV	DATE	BY	CHKD	APPD
TITLE: <b>ROLLER BLOCK CHARGING SIDE</b>				
CADD CODE: U 01				

REV	DATE	ALTERED / CHECKED / APPROVED
REV	DATE	ALTERED / CHECKED / APPROVED
ZONE		





ALL DIMENSIONS ARE IN MILLIMETRES

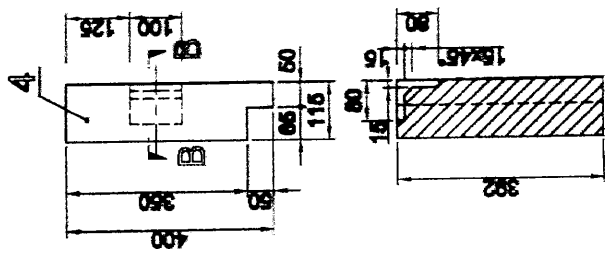
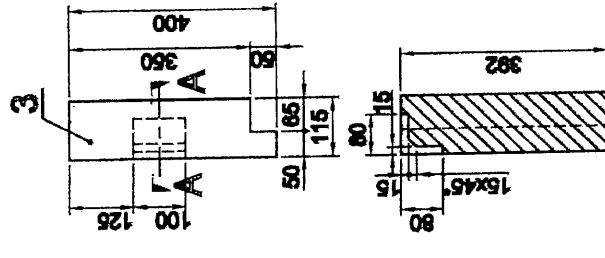
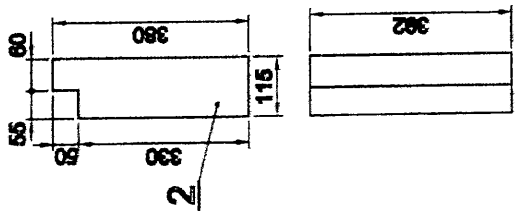
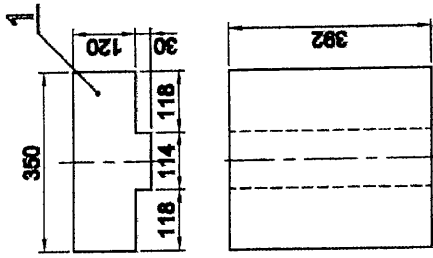

SECTION-AA

SECTION-BB

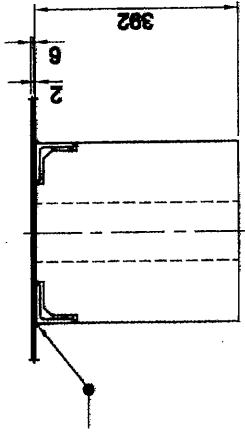
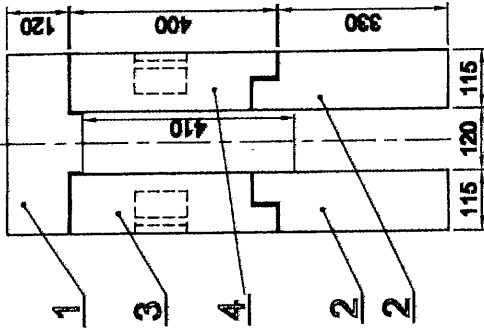

4	55%AL <sub>2</sub> O <sub>3</sub>	1	33
3	55%AL <sub>2</sub> O <sub>3</sub>	1	33
2	55%AL <sub>2</sub> O <sub>3</sub>	2	32
1	55%AL <sub>2</sub> O <sub>3</sub>	1	36
ITEM NO	MATERIAL	QTY	WT(KG)

NOTES:

- 1) THE REFRACTORIES SHALL BE COMPACT, OF HOMOGENEOUS TEXTURE AND FREE FROM CRACKS, Voids AND OTHER FLAWS. THEY SHALL BE BURNT EVENLY THROUGHOUT AND SHALL HAVE SUFFICIENT MECHANICAL STRENGTH AND NO SOFT CORNERS.
- 2) ALL CORNERS TO BE MIN. R<sub>2</sub>mm R<sub>1</sub>mm.
- 3) TOLERANCE ON SIZE: ±
- 4) BRICKS TO BE INSPECTED IN ASSEMBLED CONDITION WITH OUT MOTOR

ITEM NO	DESCRIPTION	DRAWING NO	MATL CODE	UNIT WT	QTY
					8
EQPT: WALKING BEAM FURNACE					
Bharat Heavy Electricals Ltd SEAMLESS STEEL TUBE PLANT TIRUCHIRAPALLI - 620014			DATE	28.12.04	
DEPT	MPG	GRADE OF UNITS, DIM	SCALE	WEIGHT(KG)	REV
		φ/D/H	1:10	166	00
REV	DATE	APPROVED	DRAWING NO : FA-0428-1B		
			3-7-1150-01-04714		
			CARD CODE U 01		
			DRAWING NO : 3-7-1150-01-04714		
			REV 00		



ALL DIMENSIONS ARE IN MM

CAUTION: THE INFORMATION ON THIS DOCUMENT IS THE PROPERTY OF BHARAT HEAVY ELECTRICALS LTD  
IT MUST NOT BE USED DIRECTLY OR INDIRECTLY IN ANYWAY DETERMINAL TO INTEREST OF THE COMPANY

REV 01	DATE	ALTERED
		CHECKED
		APPROVED

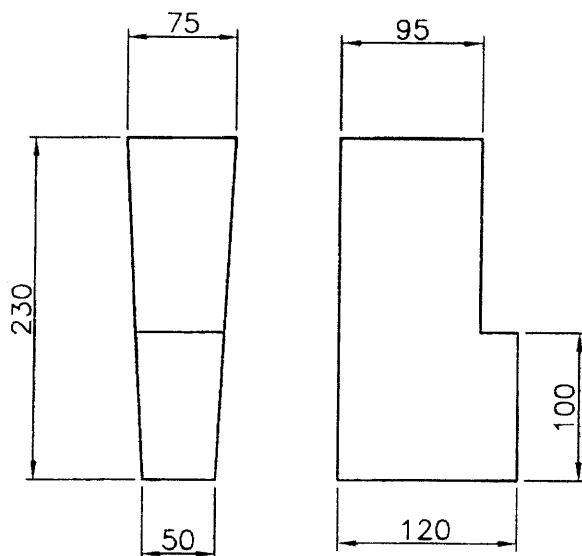

**NOTES:**

1. THE REFRACTORIES SHALL BE COMPACT, OF HOMOGENEOUS TEXTURE AND FREE FROM CRACKS, VOIDS AND OTHER FLAWS, THEY SHALL BE BURNT EVENLY THROUGHOUT, AND SHALL HAVE SUFFICIENT MECHANICAL STRENGTH AND NO SOFT CORNERS.
2. ALL CORNERS TO BE MINIMUM 3 mm. RADII, UNLESS OTHERWISE STATED.
3. TOLERANCE ON SIZE  $\begin{matrix} +0 \\ -1 \end{matrix}$

			55-60% AL <sub>2</sub> O <sub>3</sub>	10
ITEM NO	DESCRIPTION	DRAWING NO	MATL CODE	UNIT WT
			MATL SPEC	QTY

EQPT: **ROTARY HEARTH FURNACE**



Bharat Heavy Electricals Ltd  
SEAMLESS STEEL TUBE PLANT  
TIRUCHIRAPALLI - 620014

DRN	NAME SSN.KUMAR	SIGNATURE <i>SSN.Kumar</i>	DATE 15.12.04
CHD			
APPD	B.SHANMUGASUNDARAM	<i>S. Shanmugasundaram</i>	16/12/04

DEPT MPG	GRADE OF UNTOL. DIM G/M/F		SCALE 1:5	WEIGHT (Kg) 3.8	REF TO ASSY DRG	ITEM NO
CODE					REF TO OLD DRG FA-0427-3/10	

TITLE <b>END ARCH CHARGING &amp; DISCHARGING DOORS</b>	CARD CODE U 01	DRAWING NO : <b>4-7-1101-01-06286</b>	REV <b>00</b>
---	----------------------	--	------------------

CAUTION: THE INFORMATION ON THIS DOCUMENT IS THE PROPERTY OF BHARAT HEAVY ELECTRICALS LTD IT MUST NOT BE USED DIRECTLY OR INDIRECTLY IN ANYWAY DETERMINANT TO INTEREST OF THE COMPANY

ALL DIMENSIONS ARE IN MM

REV 01	DATE	ALTERED
		CHECKED
		APPROVED

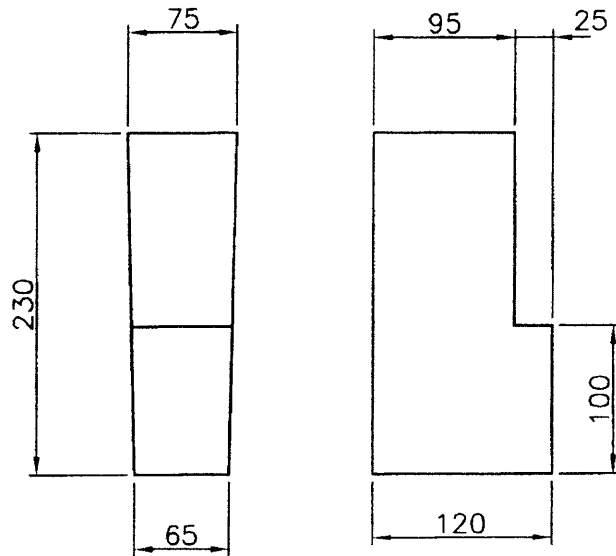

**NOTES:**

- 1. THE REFRACTORIES SHALL BE COMPACT, OF HOMOGENEOUS TEXTURE AND FREE FROM CRACKS, VOIDS AND OTHER FLAWS, THEY SHALL BE BURNT EVENLY THROUGHOUT, AND SHALL HAVE SUFFICIENT MECHANICAL STRENGTH AND NO SOFT CORNERS.**
- 2. ALL CORNERS TO BE MINIMUM 3 mm.RADII, UNLESS OTHERWISE STATED.**
- 3. TOLERANCE ON SIZE  $\begin{matrix} +0 \\ -1 \end{matrix}$**

ITEM NO	DESCRIPTION	DRAWING NO	55-80% AL <sub>2</sub> O <sub>3</sub>	10
			MATL CODE	UNIT WT
			MATL SPEC	QTY

EQPT: **ROTARY HEARTH FURNACE**



Bharat Heavy Electricals Ltd  
SEAMLESS STEEL TUBE PLANT  
TIRUCHIRAPALLI - 620014

DRN	NAME SSN.KUMAR	SIGNATURE <i>S.S.N. Kumar</i>	DATE 15.12.04
CHD			
APPD	B.SHANMUGASUNDARAM	<i>S. Shanmugasundaram</i>	16/12/04

DEPT MPG	GRADE OF UNTOL DIM E/M/F		SCALE 1:5	WEIGHT (Kg) 4.2	REF TO ASSY DRG	ITEM NO
CODE					REF TO OLD DRG FA-0427-3/11	

TITLE <b>END ARCH CHARGING &amp; DISCHARGING DOORS</b>	CARD CODE U 01	DRAWING NO : <b>4-7-1101-01-06287</b>	REV <b>00</b>
---	-------------------	--	------------------

30

ALL DIMENSIONS ARE IN MM

CAUTION: THE INFORMATION ON THIS DOCUMENT IS THE PROPERTY OF BHARAT HEAVY ELECTRICALS LTD  
IT MUST NOT BE USED DIRECTLY OR INDIRECTLY IN ANYWAY DETERMINAL TO INTEREST OF THE COMPANY.

REV	DATE	ALTERED
01		CHECKED
		APPROVED

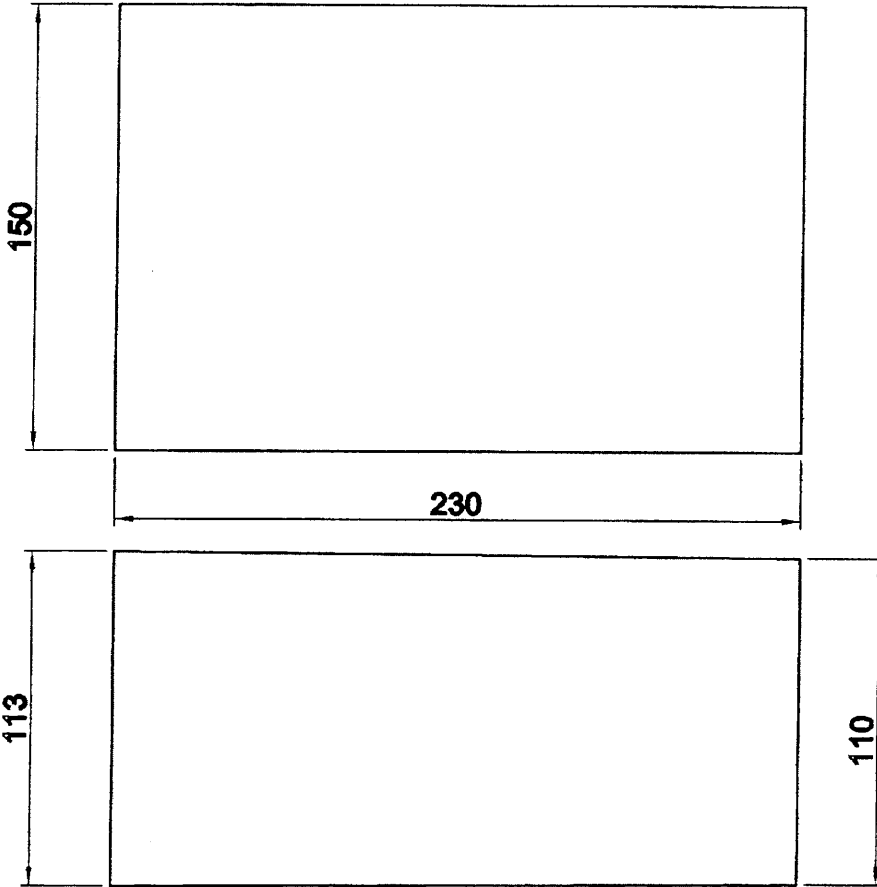

**NOTES:**

- 1) THE REFRACTORIES SHALL BE COMPACT, OF HOMOGENEOUS TEXTURE AND FREE FROM CRACKS, VOIDS AND OTHER FLAWS. THEY SHALL BE BURNT EVENLY THROUGHOUT AND SHALL HAVE SUFFICIENT MECHANICAL STRENGTH AND NO SOFT CORNERS.
- 2) ALL CORNERS TO BE MIN. 5mm RADII.

31

			55%-60% AL <sub>2</sub> O <sub>3</sub>	455
ITEM NO	DESCRIPTION	DRAWING NO	MATL CODE	UNIT WT
			MATL SPEC	QTY

EQPT: ROTARY HEARTH FURNACE

	Bharat Heavy Electricals Ltd		DRN	NAME	SIGNATURE	DATE
	SEAMLESS STEEL TUBE PLANT		CHD	P. RAMAKRISHNAN	<i>[Signature]</i>	29.12.04
	TIRUCHIRAPALLI - 620014		APPD	SSN.KUMAR	<i>[Signature]</i>	1/1/05
				B.SHANMUGASUNDARAM	<i>[Signature]</i>	01/01/05

DEPT	GRADE OF UNTOL DIM	SCALE	WEIGHT (Kg)	REF TO ASSY DRG	ITEM NO
MPG	C/M/F	1:2.5	9.6	REF TO OLD DRG	
CODE				358105 1/2-3	

TITLE	CARD CODE	DRAWING NO :	REV
OUTER WALL SUPPORTING BRICK-III	U 01	4-7-1101-01-06303	00

CAUTION: THE INFORMATION ON THIS DOCUMENT IS THE PROPERTY OF BHARAT HEAVY ELECTRICALS LTD  
IT MUST NOT BE USED DIRECTLY OR INDIRECTLY IN ANYWAY DETERMINAL TO INTEREST OF THE COMPANY

REV 01	DATE	ALTERED
		CHECKED
		APPROVED

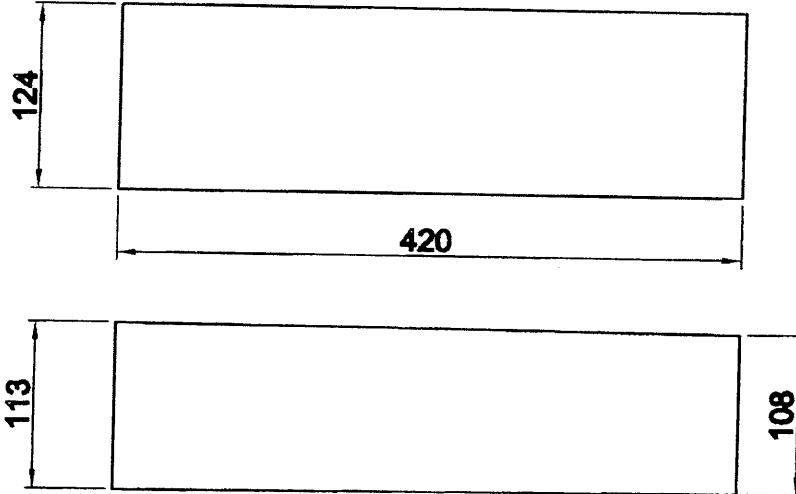

**NOTES:**

- 1) THE REFRACTORIES SHALL BE COMPACT, OF HOMOGENEOUS TEXTURE AND FREE FROM CRACKS, VOIDS AND OTHER FLAWS. THEY SHALL BE BURNT EVENLY THROUGHOUT AND SHALL HAVE SUFFICIENT MECHANICAL STRENGTH AND NO SOFT CORNERS.
- 2) ALL CORNERS TO BE MIN. 5mmRADII.

32

			55%-60% AL <sub>2</sub> O <sub>3</sub>	730
ITEM NO	DESCRIPTION	DRAWING NO	MATL CODE	UNIT WT
			MATL SPEC	QTY

EQPT: **ROTARY HEARTH FURNACE**

	Bharat Heavy Electricals Ltd SEAMLESS STEEL TUBE PLANT TIRUCHIRAPALLI - 620014	DRN	NAME P. RAMAKRISHNAN	SIGNATURE <i>P. Ramakrishnan</i>	DATE 20.12.04
		CHD	SSN.KUMAR	<i>SSN.Kumar</i>	1/1/05
		APPD	S.SHANMUGASUNDARAM	<i>S. Shanmugasundaram</i>	01/01/05

DEPT MPG	GRADE OF UNTOL DIM C/M/F		SCALE 1:5	WEIGHT (Kg) 14.5	REF TO ASSY DRG	ITEM NO
CODE					REF TO OLD DRG 358105 1/2-4	

TITLE <b>OUTER WALL SUPPORTING BRICK-IV</b>	CARD CODE U 01	DRAWING NO : <b>4-7-1101-01-06304</b>	REV <b>00</b>
--	-------------------	--	------------------

CAUTION: THE INFORMATION ON THIS DOCUMENT IS THE PROPERTY OF BHARAT HEAVY ELECTRICALS LTD IT MUST NOT BE USED DIRECTLY OR INDIRECTLY IN ANYWAY DETERMINAL TO INTEREST OF THE COMPANY

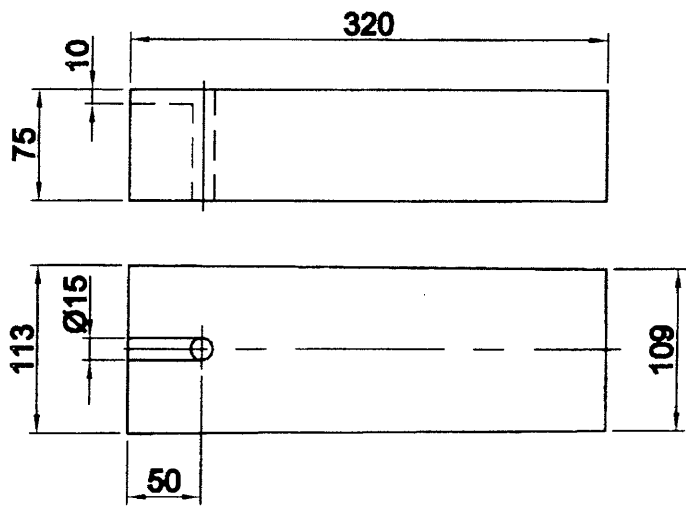

ALL DIMENSIONS ARE IN MM

REV 01	DATE	ALTERED
		CHECKED
		APPROVED



**NOTES:**

- 1) THE REFRACTORIES SHALL BE COMPACT, OF HOMOGENEOUS TEXTURE AND FREE FROM CRACKS, VOIDS AND OTHER FLAWS. THEY SHALL BE BURNT EVENLY THROUGHOUT AND SHALL HAVE SUFFICIENT MECHANICAL STRENGTH AND NO SOFT CORNERS.
- 2) ALL CORNERS TO BE MIN. 5mmRADII.

				55%-60% AL <sub>2</sub> O <sub>3</sub>		94	
ITEM NO	DESCRIPTION	DRAWING NO		MATL CODE	UNIT WT		
				MATL SPEC	QTY		
EQPT: <b>ROTARY HEARTH FURNACE</b>							
		Bharat Heavy Electricals Ltd SEAMLESS STEEL TUBE PLANT TIRUCHIRAPALLI - 620014		DRN	NAME P. RAMAKRISHNAN	SIGNATURE <i>P. Ramakrishnan</i>	DATE 29.12.04
				CHD	SSN.KUMAR	<i>S. Shanmugasundaram</i>	1/1/05
				APPD	S.SHANMUGASUNDARAM	<i>S. Shanmugasundaram</i>	01/01/05
DEPT MPG	GRADE OF UNTOL DIM C/M/F		SCALE 1:5	WEIGHT (Kg) 6.6	REF TO ASSY DRG		ITEM NO
CODE					REF TO OLD DRG 358105 1/2-10		
TITLE <b>OUTER WALL ANCHOR BRICK-III</b>				CARD CODE U 01	DRAWING NO : <b>4-7-1101-01-06310</b>		REV <b>00</b>

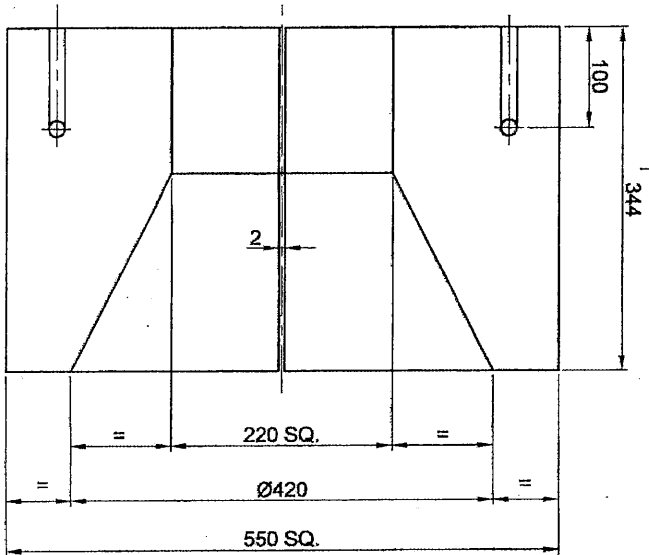
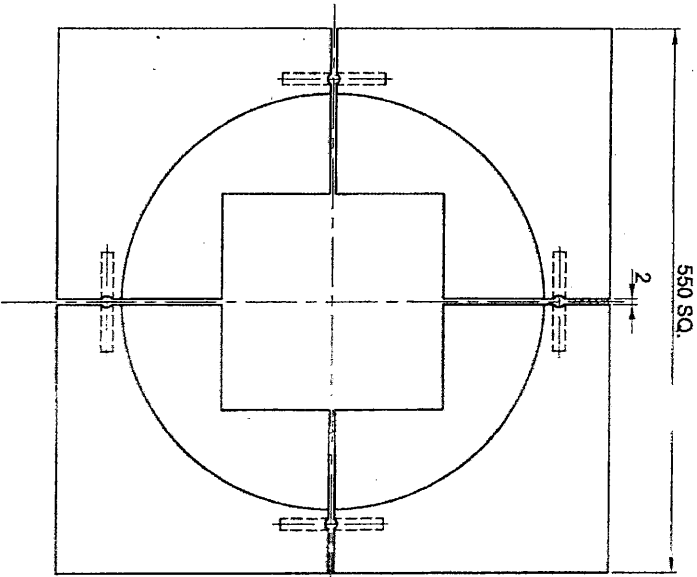

ALL DIMENSIONS ARE IN MILLIMETRES

DETAIL OF ONE SEGMENT

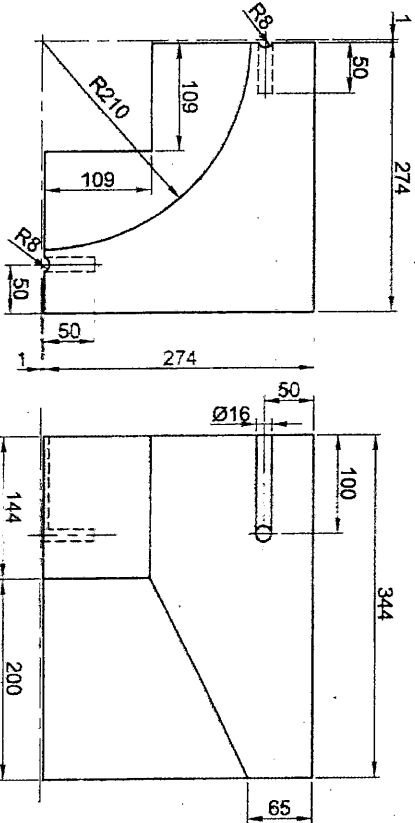

NOTES:

1. THE REFRACTORIES SHALL BE COMPACT, OF HOMOGENEOUS TEXTURE AND FREE FROM CRACKS, VOIDS AND OTHER FLAWS. THEY SHALL BE BURNT EVENLY THROUGHOUT, AND SHALL HAVE SUFFICIENT MECHANICAL STRENGTH AND NO SOFT CORNERS.
2. ALL CORNERS TO BE MIN. 3mm RADII.
3. TOLERANCE ON SIZE +0 -1

REV	DATE	ALTERED:
02		CHECKED: APPROVED:

REV	DATE	ALTERED:
01	09-04-05	CHECKED: APPROVED:

DIMENSION 109 WAS 107

ITEM NO	DESCRIPTION	DRAWING NO	55-60% AL <sub>2</sub> O <sub>3</sub>	UNIT WT
				16

EQPT: WALKING BEAM FURNACE



Bharat Heavy Electricals Ltd  
 SEAMLESS STEEL TUBE PLANT  
 TRUCHIRAPALLI - 620014

DRN	NAME	SIGNATURE	DATE
DRN	SSN/KUMAR	<i>S.S. Kumar</i>	18.12.04
CHD			
APPD	S. SHANMUGASUNDARAM		

DEPT	MPG	GRADE OF UNIT	SCALE	WEIGHTED	WGT TO ASSY DWG NO	REF TO QTD DWG NO	ITEM NO
MPG	UNIT	1:5	188	FA-0428-1A			

TITLE  
 BURNER BLOCK GUARD

CAD CODE	DRAWING NO :	REV
U 01	3-7-1150-01-04709	01