

The information on this document is the property of BHARAT HEAVY ELECTRICALS LIMITED. It must not be used directly or indirectly in any way detrimental to the interest of the company.

DRAWING No. 3-13-572-62-34-01

First Angle Projection

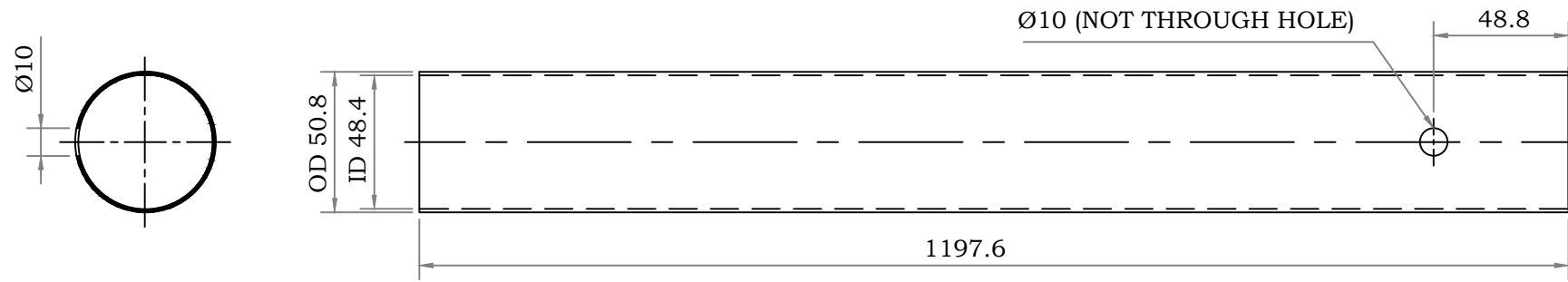

CONTAINER (Pipe OD 50.8, Wall Thickness 1.2)

MATERIAL : SS 202
QUANTITY : 36 Nos.

All dimensions are in MM

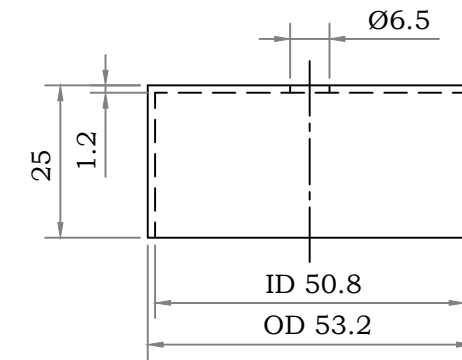

END CAP (TOP)

MATERIAL : SS 202
QUANTITY : 36 Nos.

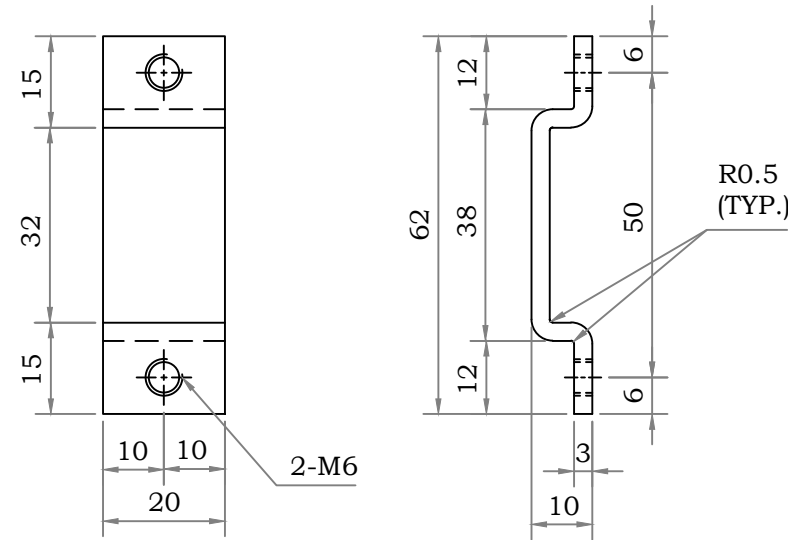

SHADOW COVER BRACKET

MATERIAL : SS 202
QUANTITY : 108 Nos.

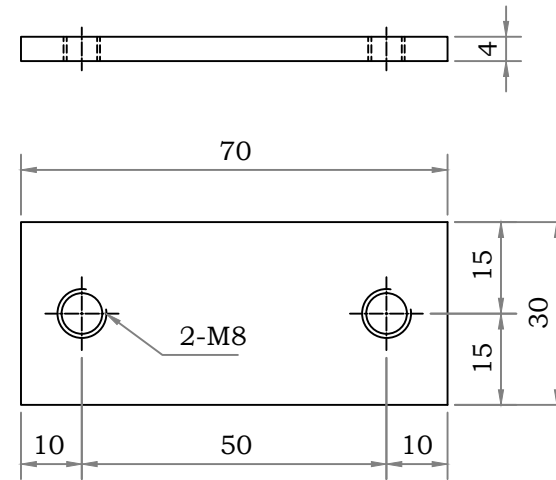

CONTAINER PLATE

MATERIAL : SS 202
QUANTITY : 72 Nos.

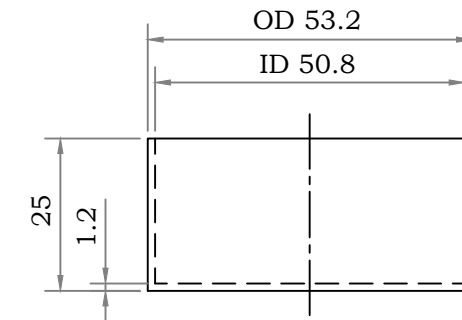

END CAP (BOTTOM)

MATERIAL : SS 202
QUANTITY : 36 Nos.

NOTES :

- MATERIAL SHALL BE STRAIGHTENED BEFORE FABRICATION.
- ALL JOINTS ARE TO BE WELDED UNLESS OTHERWISE SPECIFIED.
- END CAP (TOP & BOTTOM) SHALL BE WELDED TO THE CONTAINER AT BOTH THE ENDS (STUDY **CONTAINER (RIGHT SIDE), DRAWING No. 3-13-572-62-34-00** BEFORE WELDING).
- CONTAINER PLATE AND SHADOW COVER BRACKET SHALL BE WELDED TO THE CONTAINER AS PER THE DIMENSION AND ORIENTATION SHOWN IN THE **CONTAINER (RIGHT SIDE), DRAWING No. 3-13-572-62-34-00**.
- SHARP CORNERS/BURRS SHALL BE REMOVED/SMOOTHENED.

ITEM No.	DESCRIPTION	DRAWING No.	MTL. SPCN.	QTY.	UNIT WT. (Kg.)
			MTL. CODE		

TYPE OF PRODUCT OR NAME OF THE CUSTOMER/PROJECT: **Field Demonstration of 100 kWp SPV System with Solar Thermal Sun Trackers**

BHARAT HEAVY ELECTRICALS LTD. CORPORATE RESEARCH AND DEVELOPMENT	NAME	SIGN	DATE	No. OF VAR
	DRN	KVPR RAO		
	CKD	SURYA ASP		
APPD	M R PAWAR			

DEPT	MATERIAL	SCALE	TOTAL WT. (Kg.)	REF. TO ASSY. DRG.	ITEM No.	No. OF ITEM
FCR	SS 202	NTS		3-13-572-62-34-00		
CODE						
62						

TITLE	DRAWING No.	REV.
CONTAINER PARTS (RIGHT SIDE) (50 kWp HORIZONTAL AXIS PASSIVE TRACKERS)	3-13-572-62-34-01	0
SHT. No.	No. OF SHTS.	