



Bharat Heavy Electricals Limited

Boiler Auxiliaries Plant
RANIPET – 632 406, Tamil Nadu, India
Purchase Department - Desalination

Open Tender for Supply of MIXED BED SYSTEM & ACCESSORIES FOR KPCL- YELAHANKA CCPP,370MW,RODM

Enquiry No.: 7760383E Dated 29/06/2016

Due on: 28.07.2016

To All [Manufacturers only.](#)

Dear Sir,

Please submit your lowest quotation on **FIRM PRICE**, in duplicate subject to our terms & conditions in the various annexures attached and herein for the below listed materials so as to reach us on or before the due date by 2.00 p.m.

[Requirement with Delivery date-FOR SUPPLY:](#)

Enquiry Sl. No.	Description & material Code	Unit	Qty.	Delivery Date
001	RWT603930001 MSRL DEGASSER TOWER WITH INTERNALS & ACCESSORIES.	SET	1.00	24/01/2017
002	RWT603930002 DEGASSER BLOWERS WITH MOTORS,DUCTS,SUCTION FILTERS, INLET AND OUTLET CONTROLS/VALVES & ACCESSORIES ETC AS PER THE TECH. SPECIFICATION ROS:6154 & 4140	SET	2.00	24/01/2017
003	RWT6039300003 MSRL DEGASSER WATER STORAGE TANK-20 M3 AND ACC.	SET	1.00	24/01/2017
004	RWT603930004 MIXED BED VESSEL WITH INTERNAL LATERALS AND ACCES SORIES.	SET	1.00	24/01/2017
005	RWT603930005 MIXED BED (MB) FEED PUMPS WITH DRIVE MOTORS AND ALL ACCESSORIES.	SET	2.00	24/01/2017
006	RWT603930006 MB REGENERATION PUMPS WITH DRIVE MOTORS AND ALL ACCESSORIES.	SET	2.00	24/01/2017
007	RWT603930007 MB BLOWERS WITH DRIVE MOTORS & ACCE. AS PER TECH. SPECIFICATION.	SET	2.00	24/01/2017
008	RWT603930008 ACID MEASURING TANK (AMT) - 1 NO. & CAUSTIC DILUTION TANKS (CDT) - 1 NOS. WITH AGITATOR, EJECTORS-02 NOS AND ACCESSORIES.	SET	1.00	24/01/2017
009	RWT603930009 MB SYSTEM FRONTAL PIPING (CPVC), WITH PENUMATIC OPERATED DIAPHRAGM VALVES ETC. AS PER THE TECH. SPECIFICATION.	SET	1.00	24/01/2017
010	RWT603930010 MB RESIN (CATION & ANION FOR 1 NO. OF MB VESSEL)	SET	1.00	24/01/2017



Bharat Heavy Electricals Limited

Boiler Auxiliaries Plant

RANIPET – 632 406, Tamil Nadu, India

Purchase Department - Desalination

Enquiry Sl. No.	Description & material Code	Unit	Qty.	Delivery Date
011	RWT603930011 BULK CHEMICAL STORAGE SYSTEM CONSISTING OF : BULK ACID TANK(15 CU.M) & ACC. 01 SET, ACID UNLOADING PUMPS WITH MOTOR ASSY. - 02 NOS AND BULK ALKALI STORAGE TANK (15 CU.M) & ACC. 01 SET & ALKALI UNLOADING PUMPS WITH MOTOR ASSY. - 02 NOS.	SET	1.00	24/01/2017
012	RWT603930012 INTERCONNECTING PIPING (UPVC/CPVC) BETWEEN EQUIPMENT & VALVES & ACCESSORIES, BULK STORAGE SYSTEM (CPVC) & DISTRIBUTION AS PER THE TECH. SPECIFICATION.	SET	1.00	24/01/2017
013	RWT603930013 FOUNDATION BOLTS, APPLICABLE FASTENERS, GASKETS, LADDERS, PLATFORM FOR MB, SUPPORTS (FOR PIPING & VALVES) AND MISCELLANEOUS.	SET	1.00	24/01/2017
014	RWT603930014 N-PIT EFFLUENT TRANSFER PUMP WITH MOTOR ASSY & ACCAS PER TECHNICAL SPECIFICATION.	SET	2.00	24/01/2017
015	RWT603930015 PRIMING CHAMBER ASSY. WITH ACCESSORIES FOR N- PIT EFFLUENT TRANSFER PUMP AS PER P&ID AND TECHNICAL SPECIFICATION.	SET	2.00	24/01/2017
016	RWT603930016 DIFFUSER PIPING ARRANGEMENT FOR N-PIT AS PER TECH. SPECIFICATION.	SET	1.00	24/01/2017
017	RWT603930017 VALVES (MANUAL BFV, DIAPHRAGM, BALL VALVE & AUTO PNEUMATIC OPERATED DIAPHRAGM VALVES) AS PER THE TECH. SPECIFICATION.	SET	1.00	24/01/2017
018	RWT603930018 ELECTRICALS, CONTROLS & INSTRUMENTATIONS AS PER TECH. SPEC. NO. ROS: 4140 AND P&ID.	SET	1.00	24/01/2017
021	RWT603930021 MANDATORY SPARES (MECH. & E C&I) AS PER TECH. SPEC. ROS: 6154 & 4140. AS PER ANNEXURE - C3	SET	1.00	24/01/2017

Requirement with Delivery date-FOR SERVICES:

Enquiry Sl. No.	Description & material Code	Unit	Qty.	Delivery Date
019	RWT603930019 COLLECTION OF MATERIAL FROM SITE STORE, ERECTION, COMMISSIONING & PG TEST OF THE MB SYSTEM.	SET	1.00	24/04/2017



Bharat Heavy Electricals Limited

Boiler Auxiliaries Plant
RANIPET – 632 406, Tamil Nadu, India
Purchase Department - Desalination

020	RWT603930020 TRIAL OPERATION OF THE MB SYSTEM FOR ONE MONTH PERIOD AFTER THE COMMISSIONING PROTOCOL.	SET	1.00	24/05/2017
-----	---	-----	------	------------

Enquiry Sl. No.	Description & material Code	Unit	Qty.	Delivery Date
OPTIONAL PRICE	RECOMMENDED SPARES FOR 3 YEARS O&M -LIST OF SPARES WITH PRICE BREAKUP TO BE FURNISHED. NOTE: THIS ITEM WILL BE ORDERED IF REQUIRED ONLY AND THIS ITEM WILL NOT BE CONSIDERED FOR ARRIVING RANKING	SET	1.00	Ordered later if required
OPTIONAL PRICE	DIEM CHARGES FOR THE TRIAL OPERATION BEYOND 1 MONTH ON PRO RATA BASIS. (THIS WILL BE OPERATED IF REQUIRED ONLY)	Per Day	1.00	Ordered later if required

BIDDERS SHALL CAREFULLY READ THE FOLLOWING ANNEXURES / NOTES AND SHALL QUOTE THEIR BEST COMPETITIVE PRICE.

PLEASE REFER TO,

- 1. ANNEXURE-A FOR STANDARD TERMS & CONDITIONS (FOR GUIDANCE TO THE SUPPLIERS)**
- 2. ANNEXURE-B FOR COMMERCIAL TERMS AND CONDITIONS**
- 3. ANNEXURE-C 1 PRICE BID FORMAT FOR THE SUPPLY**
- 4. ANNEXURE-C 2 PRICE BID FORMAT FOR THE SERVICES & OPTIONAL PRICES.**
- 5. ANNEXURE-C3 PRICE BID FORMAT FOR THE BREAKUP PRICE FOR THE MANDATORY SPARES& COMMISSIONING SPARES.**
- 6. ANNEXURE-D SDDR FORMAT**
- 7. CEBG FORMAT**
- 8. ON LINE SUPPLIER REGISTRATION FORM**

9. TECHNICAL ENCLOSURES AS PER FOLLOWINGS:

01. Technical Specification for MB System-: ROS 6154 Rev: 00, Dt:18.06.2016.
- 01A. Tech Spec ROS: 6154, Rev: 00-for E&C, PG Test & Handing Over.
02. Tech Spec for MB System-E, C&I Package: ROS: 4140 Rev:00 Dt: 18.06.2016.
03. Approved Vendor list 4 WT 220 00488 REV 00
04. MB P&ID Drawing No.1-WT-220-00711, Rev: 00,
05. Legend for P&ID Drawing No.2-WT-220-0211, Rev: 01.
06. MB Equipment Layout Drawing No.1-WT-220-00712, Rev: 00,
07. Painting Specification PRQA - 526, Rev: 01,
08. Technical Annexure-B Mandatory Spares List
09. Qualification Requirement
- 09A. Qualification Data sheet Annexure I
- 09B. Qualification Data sheet Annexure II



Bharat Heavy Electricals Limited

Boiler Auxiliaries Plant

RANIPET – 632 406, Tamil Nadu, India

Purchase Department - Desalination

Important Instruction to Bidders:

1. All the items will be procured from a single vendor only & all the Items will be compared on SET Basis & Order will be placed on a Single vendor who is the lowest (L1) on set basis. Hence please quote for all the complete items including services. Incomplete offers will be rejected.
2. Vendors shall go through the “Qualification Requirement” & furnish Qualification Data sheet duly filled in along with Techno-Commercial offer. Offers received without this requirement will be summarily rejected & such offers will not be processed further.
3. Price bid opening will be considered subject to techno commercial confirmation and acceptance by BHEL,Ranipet & also approval from our customer : M/s KPCL,Yelahanka,Karnataka.

➤ TENDER SHALL BE SUBMITTED IN TWO PARTS AS REFERRED IN ANNEXURE-B.

➤ ANY REVISED OFFER(S) SENT BY VENDORS ON THEIR OWN, AFTER THE TENDER OPENING, WILL BE TREATED AS "UNSOLICITED OFFER". SUCH OFFERS WILL NOT BE CONSIDERED AND NECESSARY ACTION AS DEEMED FIT WILL BE TAKEN BY BHEL ON THOSE VENDORS. HENCE COMPETITIVE OFFER TO BE GIVEN IN THE ORIGINAL QUOTE ITSELF.

IMPORTANT NOTE:

TENDERS ARE INVITED THROUGH ELECTRONIC MODE FROM ELIGIBLE SUPPLIERS IN CASE OF OPEN TENDERS AND FROM SUPPLIERS TO WHOM THE ENQUIRY IS ADDRESSED IN CASE OF LIMITED / SINGLE TENDER.

THE OFFERS SHALL BE POSTED INTO THE SYSTEM BEFORE THE DATE AND TIME SPECIFIED IN THE TENDER.

THE OFFER SHALL BE SENT ON ~~SINGLE PART~~ / TWO PART / ~~THREE PART~~ BASIS AS SPECIFIED IN THE MAIN TENDER DOCUMENT.

BIDS SHALL BE SUBMITTED THROUGH E-PROCUREMENT PORTAL, <https://bheleps.buyjunction.in> OF M/s mJUNCTION SERVICES LIMITED WHO ARE OUR SOLUTION PROVIDER.

- 01) OFFERERS ARE REQUESTED TO CAREFULLY READ THE FOLLOWING CONDITIONS AND GIVE THEIR SPECIFIC CONFIRMATION OF ACCEPTANCE IN TOTO.
- 2A) TIME IS THE ESSENCE OF CONTRACT.
- 2B) IN THE EVENT OF DELAY ON THE CONTRACT DELIVERY, LIQUIDATED DAMAGES (LD) WILL BE LEVIED.
- 2C) LD WILL BE LEVIED AT THE RATE OF 0.5 % PER WEEK OR PART THEREOF ON THE CONTRACT VALUE.
- 2D) THE LD CEILING WILL BE 10 %.
- 2E) LD WILL BE A MANDATORY CONDITION IN THE PURCHASE ORDER.
- 3) IF NO CONFIRMATION OR COMMENTS ARE INCLUDED IN THE INITIAL OFFER BY THE TENDERER, IN THE EVENT OF PLACEMENT OF ORDER, THE ORDER WILL BE RELEASED WITH THE STANDARD LD CONDITION GIVEN ABOVE.
- 4) THE CONDITION WILL BE INCLUDED IN THE ORDER WITHOUT ANY FURTHER REFERENCE TO THE OFFERER AND NO CHANGES WILL BE PERMISSIBLE, POST ORDER RELEASE.

~~~~~O~~~~~

## OPEN TENDER CHECKLIST

| <b>Sl. No.</b> | <b>Document Name</b>     | <b>Vendor Confirmation</b><br>(Signed copy to be submitted along with<br>Techno Commercial Offer) |
|----------------|--------------------------|---------------------------------------------------------------------------------------------------|
| 01             | Annexure A               | Submitted <input type="checkbox"/><br>Not Submitted <input type="checkbox"/>                      |
| 02             | Annexure B               | Submitted <input type="checkbox"/><br>Not Submitted <input type="checkbox"/>                      |
| 03             | Annexure C1, C2 & C3     | Submitted <input type="checkbox"/><br>Not Submitted <input type="checkbox"/>                      |
| 04             | Annexure D               | Submitted <input type="checkbox"/><br>Not Submitted <input type="checkbox"/>                      |
| 05             | QR with Annexure I or II | Submitted <input type="checkbox"/><br>Not Submitted <input type="checkbox"/>                      |
| 06             | Technical Specifications | Submitted <input type="checkbox"/><br>Not Submitted <input type="checkbox"/>                      |
| 07             | Online SRF               | Submitted <input type="checkbox"/><br>Not Submitted <input type="checkbox"/>                      |
| 08             | CEBG                     | Submitted <input type="checkbox"/><br>Not Submitted <input type="checkbox"/>                      |



**ANNEXURE –A**  
**GENERAL TERMS & CONDITIONS**  
**(FOR GUIDANCE TO THE SUPPLIERS)**

**A] Submission of Offer**

**a) Invitation for bid**

Tenders are invited through electronic mode from eligible suppliers in case of open tenders and from suppliers to whom the enquiry is addressed in case of Limited / Single Tender.

The offers shall be posted into the system before the date and time specified in the tender.

The offer shall be sent on single part / two part / three part basis as specified in the main tender document.

Bids shall be submitted through e-Procurement portal, <https://bheleps.buyjunction.in>, of M/s mJunction Services Limited who are our solution provider.

**b) Hardware and Software requirements for participating in e-tender**

Requirement for participating in e-Procurement is as under:

- i) A Computer with internet connectivity (Internet Explorer Version 9 and above).
- ii) Digital Signature Certificate (Class 3- SHA2-2048 BIT- with both Signing and Encryption component separately).
- iii) JAVA (Version 1.8 Update 45).

**c) Instructions for Registered Suppliers**

For all types of tenders (Single / Limited / Open) an automated email alert regarding issue of the Tender will be sent by the e-procurement portal to all Suppliers registered with BHEL, Ranipet for the item/s for which the tender is issued.

In case of open tenders, Registered suppliers with registered DSC will have to login with their user id/password & DSC and search for the Open Tender. On clicking the “Interest” button, they will get attached to that particular Open Tender.

Registered suppliers without DSC will have to first register themselves in <https://bheleps.buyjunction.in> as new supplier by clicking the “New Supplier” button.

To know the procedure for obtaining Digital Signature Certificate (DSC), suppliers who are not having the DSC are advised to visit our website [www.bhel.com](http://www.bhel.com) →Tender Notifications →Sample Checklist.

**d) Instructions for new suppliers wishing to bid against open tenders**

New, unregistered suppliers wanting to bid against open tender/s will have to first register themselves in <https://bheleps.buyjunction.in> as new supplier by clicking the “New Supplier” button.

After entering the Income Tax Permanent Account Number (PAN) details and pressing “Enter”, they have to click the “Interested” button against the respective BHEL Unit for which they want to participate in the Open Tender and also fill up other relevant Company information as a one-time activity.

Then, a box for filling in a “preferred login id” will appear at the top of the page. After giving the “preferred login id” and then clicking the “Next” button, Supplier would have to map their DSC (which will be activated by M/s mJunction Services Limited), if available. Or else, by pressing “skip” button and selecting relevant procurement category from the list available in the next page and “agreeing” to the BHEL’s terms & conditions, user id and password will be generated/activated once in 2 hours and mailed to their registered



email id. Using this user id and password, Supplier has to login and map the Digital Signature Certificate they have purchased to their code. The DSC will then be activated by M/s mJunction Services Limited.

As required by the tender, the necessary documents have to be filled-in online, in the provided template. Additional documents required are to be scanned and uploaded as .pdf file. Suppliers are advised to take note that the maximum space that is provided for uploading the documents that are to be attached is 300 MB. However the size of an individual document cannot exceed 10 MB. For any clarification on submission of offer on line, attention of the Supplier/s is invited to our document “Supplier Manual” hosted in the home-page of the e-procurement portal. During normal business hours, helpline maintained by the service provider mJunction is available for clarifying any doubts of supplier/s. The helpline numbers are 09840704941 or 09500199108.

Typical documents that would be required as part of tender submission would be

- a) **Filled-in QR Annexure – I (OR) II Qualification Data Sheet – Manufacturer duly filled in.**
- b) **Complete technical Offer** with details, catalogues, as applicable.
- c) **Filled-in Annexure – B (Commercial Terms & Conditions).**
- d) **Filled-in Annexure – C1, C2 & C3 (Un-priced bid (i.e. Price Bid without the Price but to clearly indicate ‘Quoted’ or ‘Not Quoted’ for each item)).**
- e) **Filled-in Annexure – D (SDDR) Deviation summary shall be submitted along with Technical Bid in two parts – giving the summary of technical deviations separately and the commercial deviations separately, if any.**
- f) **All relevant enclosures** of above documents / formats, if any.
- g) **Indigenous manufacturers only can submit their offer.**
- h) **BHEL registered Vendors:** Vendors registered with any unit of BHEL, shall give details of their registration along with the category registered for. Such Vendors may be exempted from submitting their annual reports & Clientele list.
- i) **BHEL Order Reference:** If same or similar material has been supplied to any other Unit of BHEL, the Purchase Order details (reference number and date) should be enclosed.
- j) Where asked for, **Client list** with their full address including detail of contact person with phone no., fax no. & e-mail ID (if any) to whom the same / similar items are supplied in the past two years. The date of supply may also be indicated, against each client.
- k) **Bidders who are not already registered with BHEL Ranipet** are requested to submit the Supplier Registration Form (SRF) online and a hard-copy of the same has to be sent addressed to the tender issuing authority for evaluating and registering as an approved vendor. The Supplier Development Cell (SDC) of BHEL, Ranipet would process the SRF for evaluation / registering the Supplier.

Suppliers can also upload their credentials by way of submission of Performance certificate/s issued by their customer/s detailing the quantity supplied and specification along with the un-priced PO copies and proof of supply along with the offer.

**Technical acceptance of offer by BHEL shall be based on the evaluation of offer and the submitted documents.**



**Note**

- (i) The materials offered, shall conform to the specification and scope attached in the tender.
- (ii) In case the offered materials are not conforming to the Enquiry material Specification, such offers would not be considered for evaluation and would be rejected.

Where equivalent specifications are offered, considering such offers will be at the sole discretion of BHEL. Wherever alternative standards / specifications are offered by Bidder, the Bidder shall provide sufficient documentary evidence to ensure equivalence to the designated standards / specifications, failing which the offer would be considered as not technically acceptable and hence shall stand rejected.

- (iii) All taxes and duties payable as extra to the quoted price should be specifically stated in offers (as appearing in the online template).

Offer/s from within India shall be submitted along with CST & TIN No. / Tariff No. etc, failing which the purchaser will not be liable for payment of such taxes and duties. Our TIN No. 33024364741, CST No. 1141686/01.07.2014, BHEL ECC No. AAACB4146PXM008.

- (iv) The un-priced bid shall be used to indicate relevant commercial terms such as scope of freight and insurance, applicability of duties and taxes etc. All Commercial terms are to be indicated clearly in the offer.

- (vi) No changes shall be entertained once the bid is opened unless otherwise specifically agreed to in writing by BHEL.

- (vii) Money values other than for those items appearing in the un-priced bid template shall not be indicated anywhere in the un-priced bid.

- (viii) Time required for inspection (at Supplier's works), should be clearly given in terms of numbers of working days.

- (x) **Offers sent by FAX / E-mail:** would not be entertained.

**Price Bid** in conformance with the specification and terms as given in the Un-Priced bid document.

**Caution:**

***The suppliers are severely cautioned to note that the price bid document accepts the price in figures only. It does not allow the supplier to write the value by words. Therefore all care shall be exercised by the supplier while filling in the figures. Once the price bid is opened no option is available for the supplier to retract the offer under any grounds. If a supplier, for any reason whatsoever approaches BHEL with a request for change in the price, it would be treated as going back on the offer submitted. In such cases, action would be initiated by BHEL for suspending further business dealings with such suppliers as per policy of BHEL which prevails at that point of time.***

**Foreign / Overseas suppliers are hereby informed that offers with differential currencies are not permitted for a given tender document.**

**Note**

- (i) The price break-up should be in line with technical specification / scope of the tender. (Cost of material, packing charges, forwarding charges, freight and insurance charges shall be shown appropriately, as applicable).

- (ii) Unless otherwise specified as a part of the tender condition, No Price Variation Clause will be entertained and No advance payment will be made by BHEL.



- (iii) In case, there is a discrepancy in the term quoted in techno-commercial bid and price bid, the term as per the techno-commercial bid (Part I) shall hold good and the commercial term quoted in the Price Bid (Part II) shall not be considered.
- (iv) In their own interest, all Tenderers are advised to double check their prices, applicable duties and taxes.
- (v) The quotation should be valid at least for a period of 90 days from the tender opening date.
- (vi) Indian bidders should submit the prices in Indian Rupees only.
- (vii) Foreign bidders may submit their bid in foreign currency. The currency for quoting shall be selected from the drop-down menu provided.
- (x) Indian Suppliers shall quote on FOR Destination basis only. Destination is BHEL, Ranipet Stores or BHEL Project Site as specified in the tender requirement. Foreign Suppliers shall quote on CFR Chennai Seaport Delivery and Insurance will be in BHEL's scope. No other delivery terms shall be acceptable. Shipment shall be arranged by the Seller on *Liner in / Liner out basis*. As per Government of India guidelines, BHEL Ranipet being a Government of India Undertaking the Bill of Lading shall be made with the Shipper as "Government of India". This shall be specifically confirmed by the Bidder.
- (xi) Where the cargo is containerized, Container washing charges, stuffing charges and / or any other such charges would be to the account of the supplier, where the containers are to be stuffed at the works of the supplier.

## **B] Opening of Offers**

a) **Tenders can be submitted up to 1400 Hours on tender opening due date. Part I will be opened on the same day at 1430 Hours. Results of the tender opening will be available for viewing for upto 7 days from the date of opening.**

b) Price Bid opening will be done through e-mode / Reverse Auction method ( English method) **which will be decided after techno-commercial bid evaluation is completed.** All tenderers would have to specifically give their acceptance for this in their bid/s.

### **Note**

- (i) Bids including all enclosures and supporting documents like catalogues, pamphlets, etc., shall be provided in ENGLISH language only.
- (ii) At its option, BHEL may consider extending the due date/s for the tender openings. Sufficient notice would be given by BHEL for such extensions.
- (iii) Deviations shall be summarized and provided in a "Deviation Statement", listing the points and the deviation against each point.
- (iv) BHEL reserves the right to increase or decrease the tendered quantity and to order on more than one vendor at the lowest acceptable price to BHEL. In ordering on more than one source, the ratio of quantity split will be as specified in the tender terms.

If not explicitly specified, BHEL reserves the right to split the quantity of the enquiry as follows: 70% quantity being ordered on the original lowest bidder (L1) and balance 30% on the next higher bidder/s excluding H1, who accepts the L1 price. However, the final decision to split the order rests with BHEL only.



In the event that the other than L1 suppliers do not accept the L1 price, then the balance will be reverted to the original L1 and the original L1 shall be bound to accept the balance of the enquiry quantity kept reserved for order splitting. This decision would be given by BHEL within 60 days of the price bid opening.

Notwithstanding the quantum of split that may be indicated in the main body of the enquiry, bidders are advised to note that the splitting of the orders will be decided by BHEL after the evaluation of the techno-commercial and price bids.

(v) Offers for part quantities on item level basis are not acceptable to BHEL. While tenderers can quote for some or all the tendered items, no supplier shall quote for partial quantity of any given enquiry item. Such partial offer would not be considered in the enquiry for that item. Suppliers are to note that the evaluation unless otherwise specified will be on item level and not for the tendered items as a whole.

### **C] Evaluation of Offers**

a) The price bids including the impact price (if any) of the technically acceptable offers alone shall be opened.

b) Offers with pre-conditions (like conditional discounts) for price are liable to be not considered / rejected. For evaluation such conditions would be removed and only the base offer would be considered for evaluation and comparison.

d) In the event of any change in scope / quantity arising out of the discussions, offerers would be given a chance to submit their revised offer / Impact bids. The option for the revised offer / impact offer will be triggered by BHEL. The Supplier then will have the facility to feed-in the revised price / impact price as per the provision given by BHEL. The impact price can be positive or negative (or nil). The impact price option shall contain only the price addition / deletion for such change in the scope / quantities, over and above the original scope and price quoted. The original price quoted would remain unchanged. The total price would then be computed by the arithmetic addition of the original price and the impact price. Where BHEL gives the option of submitting the revised offer, the impact would be computed as the arithmetic difference of the revised price and the original price.

e) For evaluating the overseas offers, CFR Chennai Sea Port price quoted will be taken into account. The cost to BHEL will be arrived at by loading the applicable customs duty project wise, insurance charges, inland transportation charges to BHEL stores and LC charges etc.,

f) For suppliers within Tamil Nadu state, as per prevailing VAT Act, VAT input credit is currently 5%.

g) BHEL reserves the right to reject without assigning any reasons / load any offer with factors other than already specified for such offers having deviations to BHEL Specifications, Standard Terms & Conditions at its discretion. The decision of BHEL in this regard shall be final.

h) BHEL reserves the right to reject an offer due to unsatisfactory past performance during tender finalisation / execution of a contract at any of BHEL projects / units or if unsatisfactory performance report is received from the party/s referenced by the supplier at any time during tender finalisation.

i) BHEL reserves the right to operate Purchase / Price preference to Government of India Undertakings, which shall be given as per the guidelines of Government of India given from time to time and / or relax the Terms and Conditions of the tender.

j) For the purpose of comparing prices, tender prices shall be converted to Indian rupees and the conversion shall be made by using the TT Selling rate of State Bank of India (SBI) prevailing on the date of opening of



Techno-Commercial / Unpriced bids. If the relevant day happens to be a bank holiday, then the forex rate as on the previous bank (SBI) working day shall be taken. This exchange rate will be followed till placement of order. Tenderers may please note that even if an impact price is taken as in (d) for purpose of price evaluation and arriving at the rank; the exchange rate will be taken as explained above.

k) Unless otherwise specified, evaluation will be on individual line item basis only and ordering will be on respective L1 vendors.

l) BHEL reserves the right to conduct negotiations on the “Price” and “Other Commercial Terms and Conditions” with the lowest ranked offerer at any time after the bid opening but before the release of the Purchase Order and If so required by BHEL, Supplier may have to share their costing sheet with BHEL.

m) Bidders are required to confirm in writing in their techno-commercial document that other than themselves (the bidder) none of its group companies, concerns or affiliates etc., are participating in the tender either directly or indirectly or through any other agency under the same proprietor / common partner(s)/ common Directors. If during the evaluation of the bids it is found that the bidder has submitted the offer in violation of this condition then all the offers received from the group companies would stand rejected. If such relationship is found at a later date where the Purchase Order has been issued, then BHEL would cancel the Purchase Order and initiate suitable action/s under the contract/s including but not limited to invoking the Risk Purchase clause of the order and other applicable legal provisions / guidelines of BHEL including guidelines on suspension of business dealings. (Please see clause L sub-clause c).

#### **D] Execution of the Order**

a) BHEL will have the option to pre-inspect the materials at Supplier's works by BHEL's own inspector or by third party agency appointed by BHEL or BHEL's end customer/s. The mere act of the pre-dispatch inspection (PDI) does not absolve the Supplier from giving the specifications as agreed upon in the Purchase Order. In the case of inspection being carried out by a third party inspector (TPI) as per the extant practice, the TPI would forward the Inspection Report (IR) along with Test Certificates and other related documents to the Quality Assurance (QA) Department of BHEL. The QA department after scrutinising the report/s submitted by the TPI would issue the Material Dispatch Clearance Certificate (MDCC). Suppliers are hereby informed that materials should be dispatched only after getting the MDCC, failing which the materials may be rejected on receipt at BHEL Stores.

b) In the case of overseas suppliers Inspection call for carrying out the inspection shall be given 30 days before the scheduled contract delivery date. The Inspection date/s given by the Supplier shall be on firm basis. For local Suppliers the Notice period of Inspection shall be 10 working days.

c) Deviations, if any pointed out by the visiting Inspection team of BHEL shall be corrected and the items as per specification shall be dispatched on or before the contract delivery date after getting the MDCC.

d) The final inspection for acceptance will, however be carried out at BHEL's works at Ranipet.

**e) The contract delivery date is the date of receipt at BHEL Stores for suppliers in India, applicable in the case of FOR Destination Contracts.**

**For ex-works contracts or FOR dispatching station indigenous contracts, the date of the Lorry way bill issued by the authorised transport carriers of BHEL / Railway Receipt / Courier Way bill / Airway bill or any such dispatch documents of carriage approved by BHEL would be considered as the Contract Delivery Date. In the case of CFR contracts with overseas suppliers, the B/L date shall be taken as the Contract Delivery Date**



f) Travel & other local stay cost for the Inspectors sent by BHEL will be to BHEL account, but other Inspection Charges, if any shall be to the account of the Seller only.

g) The supplier shall arrange for packing suitably in all respects for normal transport by sea / rail / road and Materials shall be suitably protected against effect of tropical salt laden atmosphere in the event of shipment being delayed at ports / store yards and as per BHEL TDC.

h) Foreign suppliers shall dispatch on CFR agreed Sea-Port basis, according to the contract conditions. Indian suppliers shall dispatch on free delivery (door-delivery) at BHEL stores basis only. Unloading the materials at BHEL Stores would be to the account of BHEL only.

i) In the event of any short supply, it shall be the responsibility of the supplier to deliver such short supplied/ missing items on Free-of-Cost basis at BHEL stores, including customs clearances at Indian Ports in the case of foreign suppliers.

k) Terms of payment:

k.1) For Indigenous Suppliers: Unless otherwise agreed to by BHEL, the standard payment terms of BHEL shall be: For non-MSE suppliers 100% payment made directly through EFT within 90 days from the date of receipt of materials at BHEL Site Stores or 90 days from the date of acknowledgement of receipt of materials at destination specified. If any supplier asks for payment terms other than the above specified, then suitable loading on cost will be considered. **Loading of any deviation in the payment terms w.r.t tender terms will be "Base rate of State Bank of India (SBI) (as applicable on the date of bid opening: Techno-commercial bid opening in case of two part bids) + 6%, will be considered for loading for the periods of relaxation sought by bidders.**

k.2) For MSE vendors (under Micro & Small category alone) 100% payment will be made within 45 days from the date of receipt of materials at BHEL Site Stores or 45 days from the date of acknowledgement of receipt of materials at destination specified.

l) NOTE:

Where the destination specified is other than BHEL Stores Ranipet, for claiming payment, Supplier has to submit proof of receipt of the materials at the destination by furnishing a copy of the acknowledged despatch document (LR/RR/Courier receipt etc.) .

If the Bidder is bidding for the first time and wants to be considered as an MSE then, the Bidder shall submit document evidencing that they are an MSE along with a certificate from a Chartered Accountant certifying the status of their Unit / Works clearly specifying the address of the works which is to be considered as MSE and send the same to BHEL, Ranipet either before the tender opening date or upload it as a part of the tender document in the e-procurement portal. Where the document is submitted electronically a hard copy shall invariably be sent within a reasonable period (not exceeding 30 days) from the bid opening date for the purpose of BHEL's records. If the hard copy is not received within this specified time, then the supplier would be treated as a non-MSE. BHEL will not be responsible for any postal / courier / delivery delays.

For approved vendors the status as on the date of the bid opening as available with BHEL Ranipet's records shall be used for reckoning the status of the Bidder as an MSE or otherwise.

Offer/s received without these documents will be treated as non-MSE and order finalization will be done based on this premise. Documents submitted after Bid-opening will not be considered in this tender. This provision for MSE will apply subject to the condition that the participating MSE meets the tender requirements.

For approved suppliers, in case of any change in the MSE status, it shall be the responsibility of the Bidder to notify the change as a part of the Bid document. If at a later date it comes to the knowledge of BHEL,



Ranipet that the change in the status has not been intimated by the Bidder and the order is obtained under the premise of an MSE then BHEL would cancel the pending order against this tender and take necessary steps for suspension of the business dealing with the Bidder as per the procurement policy of BHEL. Similarly if a supplier claims MSE status after the Part I bid opening, then the same would not be considered in the tender.

In case after the bid opening it is seen that no MSE has become L1, then depending on the nature of the item, if it is not possible to split the tendered items / quantities on account of reasons like customer contract requirements of supplying one make for a given project or technical reasons like the tendered item being a system etc. then BHEL would not counter offer the L1 prices even though there may be MSE bidders within the +15% band of L1.

Other concessions for MSEs / Reserved sectors

In addition to the concessions specified above, MSE suppliers will be eligible for such other concessions as per the MSME Act 2006 and any other benefits / concessions that may be announced by the Government of India from time to time.. However, such concessions as applicable at the time of tender opening alone will be applicable. Any concessions advised after tender opening will not be considered for the current tender.

Items that are reserved for MSE and for any other items for which reservations for Indian manufacturers are notified by the Govt. Of India, such concessions as prevailing on the date of tender opening shall apply as a part of this tender conditions.

ii) Foreign Suppliers “100% thru’ irrevocable & unconfirmed LC at sight within 3 weeks from the PO date through any one of our Bankers listed elsewhere in the tender conditions for 100% value (less Agency Commission, if any ) valid up to the PO delivery period and 15 days thereafter for negotiation. All bank charges in India to BHEL's account and all other charges outside India to Supplier's account. **BHEL reserves the right to load the price of foreign suppliers in order to bring them on common platform as per Indigenous Suppliers on the account of differential payment terms to Indigenous Suppliers. Loading of payment terms will be “Base rate of State Bank of India (SBI) (as applicable on the date of bid opening: Techno-commercial bid opening in case of two part bids) + 6%, will be considered for loading for the periods of relaxation compared to indigenous suppliers i.e. 90 days.**

m) Any incidence of tax like Income tax, Service Tax and Withholding any other similar tax / duties /levies imposed by the Government of India, or the State Government, where the BHEL Unit is located, deductible at Source, during the tenure of the Order shall be deducted by BHEL and necessary certification of the deduction (Tax deduction at Source) would be given. This is subject to the supplier fulfilling the necessary documentation as specified by the Government of India. (e.g. Tax Residency Certificate, PAN Number etc.)

n) The Guarantee period shall start from the “Date of receipt and acceptance of the materials at BHEL Stores.”

***o) Where any bidder gives extended credit period over and above that offered by BHEL, then all other Non-MSE bidders and foreign bidders would have to match the extended period of payment terms. This information would be given to such bidders after opening of the techno-commercial bids; but before opening the price bids. However bidders would not be allowed to change their price bid for purpose of confirming the extended credit period. In the event such bidder/s do not accept the extended credit period for payment, then their offer would be loaded to the extent of the differential between their offered payment terms and the revised payment terms offered by BHEL as explained above.***

#### **E] Liquidated Damages Clause:**

BHEL will levy penalty as Liquidated Damages (LD), for delay in delivery. The damages shall be at the rate of ½% per week or part thereof subject to a maximum of 10%. The contract delivery date for purpose of L.D



is the date of receipt at BHEL Stores for suppliers in India for F.O.R. Destination Contract and the date of dispatch clearance given by BHEL for overseas suppliers. For ex-works or F.O.R dispatching station contracts, the date of the dispatch document will be reckoned as the date of delivery for computing the LD. Supplier shall deduct the applicable LD from the first payment when raising the claim for the same. The applicable LD if any would be communicated by BHEL along with the dispatch clearance. It is taken by BHEL that Foreign Suppliers have confirmed their acceptance to BHEL for opening the LC for value which is the value of the order reduced by the applicable LD. The LD would apply on the undelivered portion only. In case of reasons attributable to BHEL for the delay in delivery (for e.g. delay in arranging the pre-inspection) then the delivery time would be reset to the extent of the time delay attributable to BHEL, with waiver of the LD. Delivery being the essence of BHEL's contract requirements, Unless otherwise specified the LD would apply on the undelivered portion of the contracted items. In the event that a **Supplier does not accept the LD condition above, the offer would be loaded to the extent of the shortfall with respect to upper limit specified above.**

## **F) Miscellaneous**

### **i) Role of Agents:**

BHEL will deal directly with indigenous manufacturers only.

BHEL strongly discourages the engagement of Agents in India by foreign principals, to deal with BHEL, in BHEL's tenders.

BHEL will not enter into any correspondence with an Indian Agent.

The Indian Agent will not be extended the privilege given to the principals, such as that of attending the tender openings, attending technical discussions, commercial discussions or price negotiations and such like. In case, in spite of the above, a foreign principal insists on engaging an Indian Agent, It is made clear by BHEL that:

It is the sole responsibility of the foreign principal to ensure the Agent does not represent any other foreign principal in a given tender.

An undertaking to this effect shall be given by the foreign principal that his / her Agent does not represent any other foreign principal in the tender. This document shall form a part of the techno-commercial offer.

If at any stage of the tender, BHEL finds that an Indian Agent has represented more than one foreign principal, all such offers of and all the foreign principals would be disqualified summarily in the tender inquiry.

BHEL will only give an intimation of notice of the disqualification. No correspondence would be entertained by BHEL, on their decision. Such decision of BHEL shall be irrevocable, firm and final and shall be binding on the tenderer.

BHEL, due to business reasons would ban, would have banned Indian agents from dealing with BHEL.

Any foreign principal who engages such a banned agent, or an employee of the banned agency, or any other person connected with the banned agency, at any time during the tender proceedings, would be disqualified from the tender proceedings. The decision of BHEL in this regard shall be final and be binding on the OEM. Hence in their own interests, prospective tenderers may check with BHEL, the status of their proposed agent vis-à-vis BHEL.

In view of the requirement of BHEL, it is strongly suggested that in their own interest, foreign principals may desist from engaging any Indian agent and deal with BHEL directly and it is stressed that any Main producer proposing to deal with BHEL by engaging and through an Indian Agent does so at their own risk.

BHEL shall in no way be responsible for any consequences that may arise to the foreign principal on account of the antecedents / actions of their Indian Agent.

### **In the event of the foreign principal engaging an Indian Agent:**

a) **The Supplier shall furnish an authenticated copy of the Agency Agreement with his agent detailing the precise relationship between them and their mutual interest in the business along with techno-commercial bid.**



b) The Supplier shall furnish original authorization letter for the Indian Agent. The letter shall contain name, contact person, complete postal address including phone, fax and e-mail ID. It shall also spell out the type of services to be rendered by Indian Agent.

c) Indian Agent & Agency commission: An Indian Agent can represent only one Foreign Manufacturer against a particular Tender. The FOB price quoted by the foreign bidder shall include the agency commission. However, the agency commission component payable to their Indian Agents shall be shown separately in the Offer, either as a lump-sum or as a percentage of the quoted price. This will be paid by BHEL in Indian Rupees, on satisfactory receipt & acceptance of the materials. For calculation of Rupee equivalent of Agency Commission, exchange rate as prevailing on the date of Purchase Order will be taken and

d) For all discussions, technical clarification and negotiations etc. only the principal would be authorized for interaction with BHEL. The Agent shall not be a party to the discussions / negotiations and would not be normally allowed to participate.

### **ii) Terms & Conditions of Letter of Credit (L/C) for overseas suppliers (indicated for acceptance).**

a) Unconfirmed irrevocable Letter of Credit at Sight only will be opened by BHEL. Confirmation of L/C is not preferred by BHEL. Also L.C will be opened in Lots in line with the staggered delivery.

b) All Bank charges out side India are to the Supplier's account and within India to BHEL's account.

c) In case of L/C extension caused by delays attributable to the Supplier, the L/C extension / commitment charges are to be borne by the Supplier.

### **iii) Other terms & conditions for letter of credit: - Documents for negotiation**

a) Signed Commercial invoice in quadruplicate, for a value not exceeding the draft amount, quoting the import Licence No and certifying goods evidencing shipment of the merchandise are as per Applicant's Purchase Order. The amount of invoice after deducting Indian Agent's commission, if any, should not exceed the Credit amount. (The Indian agent's commission, if any, is payable in India in Indian rupees only.)

b) Certificate of Country of Origin, from the country of manufacture, issued by the Chamber of Commerce.

c) One set of Original and two sets of Non-negotiable copies of 'signed', 'unmarked', 'clean on board' Ocean Bill of Lading, showing Shipper as "Government of India" Account M/s. Bharat Heavy Electrical Ltd, Unit: BHEL, Ranipet as consignee (The opening bank should not be notified as consignee), marked freight payable / prepaid at destination.

d) Packing list in 4 copies in English, indicating Size wise Number of bundles / pieces shipped and weight.

e) Certified copy of the fax / e-mail sent by the beneficiary to the applicant giving the following particulars of shipment, as the insurance is to be arranged by the Applicant in India: (a) Purchase Order Number & date; (b) Bill of Lading Number & date (c) Name of vessel; (d) Port of Loading; (e) Number of bundles / pieces and weight; (f) Invoice Number, date and value (g) Purchase Order item number's despatched. The cable / fax is to be sent within 2 working days of shipment.

f) Beneficiary's certificate showing the relevant airmail / courier reference no. and date that the following clauses have been complied with:

1] Beneficiary to forward by Registered Airmail / Courier one complete set of original documents and one set of non-negotiable documents within 3 working days of obtaining shipping documents to Regional Manager (ROD), Bharat Heavy Electricals Ltd, No. 165, Thambu-Chetty Street, Chennai – 600 001. India. (Phone: +91-44-25341249, 25341240 / Fax - +91-44-25340787; e-mail: raja@rodchn.bhel.co.in)



- 2] Beneficiary to courier at his cost 3 copies of complete set of non-negotiable documents to the Officer who released the Purchase Order.
- 3] Declaration by the Supplier certifying that the contents in each case are not less than those entered in the invoices / packing list and that the invoicing for the supplies effected is strictly in accordance with agreed rates as stipulated in the Purchase Order.
- 4] Declaration to the effect that all other documents as per purchase order has been couriered to the Purchase order releasing authority
- 5) The carrying steamer should be seaworthy, less than 25 years of age and approved by Lloyds / Classification Societies / General Insurance Corporation of India from time to time and
- 6) Copy of Dispatch Clearance / Instruction issued by BHEL.

**iv) Documents to be sent directly to the Purchaser prior to shipment**

- a) Manufacturer's Original Internal Inspection / Test certificate in triplicate.
- b) Manufacturer's Original Guarantee certificate as per Purchase Order. The material shall be guaranteed for a period of 12 months from the date of acceptance of the materials at BHEL stores or 18 months from the date of dispatch whichever is earlier. The acceptance would be evidenced by the Stores Receipt Voucher (SRV) which will be raised by BHEL.
- c) Inspection / Test Certificate issued by BHEL / Inspection agency specified in the Purchase Order. In the event that Inspection prior to dispatch is not carried out by the Engineers of BHEL, the Inspection certificate of the third party so authorized by BHEL and
- d) Any other documentation as specified in the Purchase Order.

**v) Conditions for transportation:**

- a) All shipping documents shall show the Purchase Order Number & Date, Import Licence Number & Date, and Letter of Credit Number & Date.
- b) Transshipment is to be avoided.
- c) Loading on deck is not permitted. The transport document must not contain a provision that goods may be carried on deck.
- d) A transport document which is produced or appearing to have been produced by reprographic, automated or computerized systems or as carbon copy will be accepted as an original document provided that it is marked as original and is ink-signed.
- e) The transport document must contain all the conditions of carriage on the original document.
- f) The transport document must not indicate the place of destination as being different from the port of discharge.
- g) The transport document must not contain the indication 'intended' or similar qualification in relation to the vessel or other means of transport or port of loading or port of discharge.
- h) The transport document must be issued by the carrier or his agent and not by any freight forwarder.
- i) Transport documents bearing reference by stamp or otherwise, to costs additional to the freight charges are not acceptable.



j) The Bills of Exchange must be dated and presentation of documents for negotiation must not be later than 15 days after the date of shipment and in any case not later than the expiry date of the Credit.

l) Indian suppliers shall dispatch the materials on freight prepaid and on door-delivery basis (FOR Destination – Destination: BHEL Stores) and

m) In the event there is a delay by the Supplier in negotiating / submitting the document, any demurrage / wharfage arising out of the same shall be to the account of the Supplier and shall be deducted from the final payment. Also, in such cases, the Supplier shall authorize the Steamer / Shipping agent / transporter to freely release the consignment to BHEL by providing a “Surrender Bill of Lading”. Over-seas Suppliers have to give a No-Objection Certificate to BHEL, authorizing BHEL to get the Delivery Order from the Steamer Agent without producing the Original Bill of Lading. This is required to ensure avoidance of incidence of demurrage at Chennai Sea-port that may arise in case of delayed presentation of documents by the Seller.

**G) Reverse auction (RA) / on-line bidding on internet:**

Against this enquiry for the subject item/ system with detailed scope of supply as per enquiry specifications, BHEL may resort to “REVERSE AUCTION PROCEDURE” i.e., ON LINE BIDDING (THROUGH A SERVICE PROVIDER). The philosophy followed for reverse auction shall be English Reverse (No ties).

1. For the proposed reverse auction, technically and commercially acceptable bidders only shall be eligible to participate.

2.a. BHEL reserves the right to go for Reverse Auction (RA) instead of opening Part I bid, submitted by the bidder. This will be decided after techno-commercial evaluation. All bidders to give their acceptance for participation in RA. Non-acceptance to participate in RA may result in non-consideration of their bids, in case BHEL decides to go for RA.

2. b. Those bidders who have given their acceptance for Reverse Auction (quoted against this tender enquiry) will have to necessarily submit “online sealed bid” in the Reverse Auction. Non-submission of “online sealed bid” by the bidder for any of the eligible items for which techno commercially qualified, will be considered as tampering of the tender process and will invite action by BHEL as per extant guidelines in vogue.

3. BHEL will engage the services of a service provider who will provide all necessary training and assistance before commencement of on line bidding on internet.

4. In case of reverse auction, BHEL will inform the bidders the details of Service Provider to enable them to contact & get trained.

5. Business rules like event date, time, bid decrement, extension etc. also will be communicated through service provider for compliance.

6. Bidders have to fax the Compliance form (annexure IV) before start of Reverse auction. Without this, the bidder will not be eligible to participate in the event.

7. In line with the NIT terms, BHEL will provide the calculation sheet (e.g., EXCEL sheet) which will help to arrive at “Total Cost to BHEL” like Packing & forwarding charges, Taxes and Duties, Freight charges, Insurance, Service Tax for Services and loading factors (for noncompliance to BHEL standard Commercial terms & conditions) for each of the bidder to enable them to fill-in the price and keep it ready for keying in during the Auction.]

8. Reverse auction will be conducted on scheduled date & time.



9. At the end of Reverse Auction event, the lowest bidder value will be known on auction portal.
10. The lowest bidder has to fax/e-mail the duly signed and filled-in prescribed format for price breakup including that of line items, if required, (Annexure VII) as provided on case-to-case basis to Service provider within two working days of Auction without fail.
11. In case BHEL decides not to go for Reverse Auction procedure for this tender enquiry, the Price bids and price impacts, if any, already submitted and available with BHEL shall be opened as per BHEL's standard practice.
12. Bidders shall be required to read the "Terms and Conditions" section of the auctions site of Service provider, using the Login IDs and passwords given to them by the service provider before reverse auction event. Bidders should acquaint themselves of the „Business Rules of Reverse Auction“ , which will be communicated before the Reverse Auction.
13. If the Bidder or any of his representatives are found to be involved in Price manipulation/ cartel formation of any kind, directly or indirectly by communicating with other bidders, action as per extant BHEL guidelines, shall be initiated by BHEL and the results of the RA scrapped/ aborted.
14. The Bidder shall not divulge either his Bids or any other exclusive details of BHEL to any other party.
15. In case BHEL goes for reverse auction & depending on the number of bidders, the H1 bidders (whose quotes are highest in online sealed bid) may not be allowed to participate in further RA process. Further, in case of sufficient vendors, exclusion of H1 bidders may get extended up to 20%.
16. **In order to bring more transparency and to address any queries of Bidders on Reverse Auction, an abridged version of BHEL's "Common Guidelines for conducting Reverse Auction (RA)" has been hosted in BHEL's web site [www.bhel.com](http://www.bhel.com) under the links "Supplier Registration Page" and "Tender Notification". All Bidders are requested to visit the link and familiarize themselves with BHEL's RA procedures and guidelines before submission of their bid/s. Submission of Bid shall mean that the Bidder has read and understood BHEL's RA procedures and the bid is in agreement with the same.**

#### **H] Force Majeure**

If at any time during the currency of this contract, the performance in whole or in part, by either party of any obligations under this contract shall be prevented or delayed by reason, of any war, hostilities, acts of the public enemy, civil commotion, sabotage, fires, explosions, epidemics, quarantine, restrictions or acts of GOD (hereinafter referred to as events), then provided notice of happening of any such events is given by either party to other within ten days from the date of occurrence thereof, neither party shall reason of such events be entitled to terminate this contract nor shall either party have any such non performance and delay is resumed as soon as practicable after such events has come to an end or ceased to exist. If the performance in whole or part of any obligation under this contract is prevented or delayed by reason or any such event claims for extension of time shall be granted for period considered reasonable by the purchaser subject to prompt notification by the seller to the purchaser of the particulars of the events and supply to the purchaser if required of any supporting evidence. Any waiver of time in respect of partial installment shall not be deemed to be a waiver of time in respect of remaining deliveries.

#### **I] Cancellation of Order:**



In the event of non-performance of the contract by the Supplier, BHEL reserves the right to cancel the order with issue of a written notice. BHEL would provide a curing period of 30 days, for the Supplier to rectify the situation. If the Supplier fails to rectify the reason/s that led to the issue of cancellation notice by BHEL, then the cancellation order would be issued automatically by BHEL, without further recourse to the Seller. BHEL will not pay any cancellation charges or any other charges / damages to the Supplier, arising out such cancellation. In the event of the non-performance of the supply contract, by the Supplier, the rights of BHEL include, in addition to cancelling the order, to take alternate purchase action at the cost and risk of the supplier. The additional expenditure to be incurred by BHEL in such alternate purchase would be to the account of the supplier. (Risk Purchase). This remedy would be in addition to the invoking of the CEBG on grounds of failure of the Supplier in executing the Contract and any other legal remedies." BHEL reserves the right to initiate the alternate purchase action at the cost and risk of the erring supplier by issue of a simple notice of intention for the alternate purchase action duly sent by any electronic means and / or by a letter. The cancellation of the order would not be a pre-condition for initiation of the alternate purchase action.

#### **J] Contract Execution Bank Guarantee:**

To demonstrate the fidelity of the successful bidder, in executing the Contract, on receipt of the Letter of Intent / Purchase Order, the Supplier shall arrange to provide a contract execution bank guarantee (CEBG). The format of the CEBG is a part of this enquiry. The format may be downloaded and necessary stamping may be obtained from the Banker towards submission of the CEBG. The indigenous suppliers have to provide the CEBG from any one of the Nationalized Banks, listed in the annexure to these terms. Overseas suppliers can submit the CEBG from any of the reputed International / National Bankers. However the CEBG is to be confirmed by any of the Bankers listed by us. In the event of failure by the Supplier to execute the contract either fully or partially, BHEL would encash the entire CEBG. The CEBG shall be valid for the period covering the agreed delivery date of the order with a further claim period of 3 months on the last specified delivery date. In the event of the failure of delivery BHEL would proceed with encashing the CEBG without reference to the Supplier. In the event of BHEL granting extension of the delivery dates, then the CEBG validity shall also be got extended by the Supplier to the extent of the extended delivery times together with the claim period as specified elsewhere. **The CEBG shall be for a value of 2% of the Purchase order.**

**Suppliers who are all already registered with BHEL and having a vendor performance rating of A or A+ grade would be exempted from submission of CEBG.**

#### **Performance Bank Guarantee**

Where ever so required, the Supplier shall arrange to provide a Performance bank guarantee (PBG). The indigenous suppliers have to provide the PBG from any one of the Nationalized Banks, listed in the tender terms. Overseas suppliers can submit the PBG from any of the reputed International / National Bankers. However the PBG shall be confirmed by any of the Bankers listed by us. The PBG shall guarantee the performance of the equipment / materials / items supplied and shall cover the guarantee period. The PBG shall have a claim period of 3 months in addition to the guarantee period. In the event of failure of the supplies made within the guarantee period, BHEL would encash the entire PBG. **The PBG shall be for a value of 10% of the Purchase order.**

**The supplier/s have to get the PBG format (pre-printed) from BHEL and get the same stamped by the Banker. Change of PBG terms either by the supplier's Banker or by the supplier, after servicing of the order is not acceptable. Similarly PBG prepared by the supplier (typed by them) will also not be acceptable to BHEL. The pre-printed form issued by BHEL shall be used for making the PBG.**



### **K] Post-order submission of documents for approval**

In the event of the release of Letter of Intent (LoI) / Purchase order/s (PO) against this tender, Bidders have to submit the applicable documents as called for in the tender / LoI / PO/s, such as drawings, data sheets, design calculations etc. These documents for approval have to be submitted within the agreed timelines between BHEL and Bidder. Normally the time period for submission for approval is 15 days from the date of receipt of the LoI / PO by the supplier. The actual time period within which the documents have to be submitted for approval would be specified in the LoI / PO.

Such documents would be subjected to evaluation and approval by BHEL and / or by BHEL's customer / Consultant / Customer's Consultant. Bidders have to give their specific acceptance for this.

After approval of such documents and after getting clearance from BHEL, only the items ordered can be taken up for manufacture.

Any changes required by BHEL / Customer etc. in the documents submitted for approval shall be incorporated by the Bidder and no extra cost would be payable by BHEL for such changes.

In the event that the Bidder does not carry out the required corrections, then the LoI / PO would be liable for cancellation by BHEL and BHEL would resort to alternate purchase action at the risk and cost of the Bidder under the Risk Purchase Condition of the Purchase Order.

*Note: After receiving the LOA / PO, supplier shall also forward the acknowledgement / acceptance of the LOA / PO by signing and returning the second copy of the LOA / PO as the token of acceptance.*

### **L] Others**

a) In case of any contradiction in the terms and conditions given here and elsewhere in the other documents of the tender, it shall be the responsibility of the tenderer to get it clarified from BHEL. The officer authorized to provide such clarifications is the tender issuing officer.

b) Alterations to the conditions of the Tender can be done only by the authorized officer, at any time before the date and time of tender opening and would be duly communicated through a corrigendum.

#### **c) Suspension of Business dealings with Suppliers:**

(i) Before submitting offer, prospective bidders are advised to visit our web-site [www.bhel.com](http://www.bhel.com) / supplier registration to familiarize themselves with BHEL's policy and procedures of Suspension of Business Dealings with Suppliers.

Submission of offer shall be deemed to be evidence of the Bidder to have read and understood the above said policy.

#### **ii) Treatment of Banned / Under-performing Vendors:**

Any supplier who has been put on "Hold" or "Banned" from having business dealings with BHEL, Ranipet or any other unit of BHEL shall not submit their offer against this tender. If any such offers are received they would be summarily rejected and sent back. During the processing of tender, if any unit of BHEL puts a supplier on "Ban" then further processing of the offer will not be taken up and in case an order is placed, BHEL, Ranipet may resort at their discretion to cancel the PO either fully or partially.

If any of the supplier who is supplying similar material to BHEL, Ranipet has a Vendor Performance Rating (VPR) score of 'C' or below, then offer given by such parties will not be considered for ordering in this tender.

#### **d) Fraud Prevention Policy:**

The Bidder along with its associate/ collaborators/ sub-contractors/ sub-vendors/ consultants/ service providers shall strictly adhere to BHEL Fraud Prevention Policy displayed on BHEL website



<http://www.bhel.com> and shall immediately bring to the notice of BHEL Management about any fraud or suspected fraud as soon as it comes to their notice.

e) **Applicability of Integrity Pact:-** Integrity Pact are applicable for all the BHEL enquiries whose estimated value is equal to or more than Rupees 05 Crores. Submission of duly-filled & signed BHEL standard format of Integrity Pact (without any deviation) by Suppliers along with the un-priced (Techno-Commercial) bid is pre-requisite condition for evaluation of the offer. Copy of Integrity Pact with applicable nominated IEM is attached along with the tender documents for ready reference of Suppliers. If any Supplier attempts to bribe, or pay commission, gift or any advantage or bring in undue influence either by himself or on his behalf any one including a stranger to the tender, in addition to instituting legal proceedings as per the extant laws prevailing, will disqualify the supplier from this tender and all future tenders of BHEL. Decision of the Purchaser would be final in this matter.

f) The laws governing this transaction shall be the laws in India.

g) Wherever not specified, Inco terms 2010 shall be used to interpret the Commercial terms and conditions and

h) In the event of an order, Supplier shall agree to settlement of disputes or differences, if any, by way of arbitration, in accordance with the "Rule of Arbitration" of the Indian Council of Arbitration.

*The language in the tender documents downloaded by the Bidders shall at no point of time be changed, altered or modified in any manner by the Tenderer. If such changes are made by any tenderer, it shall be considered as tampering with BHEL's terms and the offer shall be summarily rejected, whenever it is noticed by BHEL. Such Bidders would be disqualified from the Bidding Process and their offers would be forfeited / Bank Guarantees invoked. They would also not be allowed to participate in future tenders of BHEL.*

### **Conditions for rejection of offers:**

**Following is the list of situations which would lead to rejection of offer/s.**

**This list is not exhaustive but only indicative.**

BHEL reserve the right to reject one or all offers without assigning any reason. The decision of BHEL will be final in this regard.

- 1. If the offer fails to meet the technical requirements/specifications of the tendered item/s.*
- 2. If the offer does not meet the commercial terms & conditions, such as but not limited to delivery period specified in the tender, Delivery terms, payment terms, Liquidated damages, Risk Purchase, cancellation clause etc., including the load factors specified in the tender.*
- 3. If the bidder fails to respond to clarification sought, within a reasonable period. In case of doubts / lack of clarity on the technical and commercial offer of the bidder, BHEL will seek clarifications. Bidders are required to respond completely to such BHEL's queries within 3 working days unless otherwise agreed to in writing by BHEL for period beyond 3 days. If supplier fails to respond within 3 working days or maximum 2 working days on a reminder thereon, the offer of such bidders will be automatically dis-qualified in the tender without further recourse to informing the bidder.*

**ANNEXURE - B**  
**BHEL : BAP : RANIPET**  
**PURCHASE DESALINATION**  
**Commercial Terms and Conditions**  
**MIXED BED SYSTEM & ACCESSORIES FOR KPCL-YELAHANKA CCPP,370MW,RODM**  
**Enquiry No. 7760383E Dated 29/06/2016 Due Date 28/07/2016**

| Sl. No.                                            | DESCRIPTION                                       | BHEL (PURCHASER) REQUIREMENT                                                                                                                                                                                                                                                                                                                                                                                                                                                                                                                                                                                                                                                                                                                                                                                                             | VENDOR (SELLER) CONFIRMATION |
|----------------------------------------------------|---------------------------------------------------|------------------------------------------------------------------------------------------------------------------------------------------------------------------------------------------------------------------------------------------------------------------------------------------------------------------------------------------------------------------------------------------------------------------------------------------------------------------------------------------------------------------------------------------------------------------------------------------------------------------------------------------------------------------------------------------------------------------------------------------------------------------------------------------------------------------------------------------|------------------------------|
| <b>I</b> <u>Technical</u>                          |                                                   |                                                                                                                                                                                                                                                                                                                                                                                                                                                                                                                                                                                                                                                                                                                                                                                                                                          |                              |
| 01                                                 | SCOPE OF SUPPLY                                   | Please confirm the Scope of Supply of "Mixed Bed System Equipment, Commissioning Spares & Mandatory Spares" as per Specification No.<br>01. Technical Specification for MB System-: ROS 6154 Rev:00,Dt:18.06.2016.<br>01A . Tech Spec ROS:6154,Rev:00-for E&C,PG Test & Handing Over.<br>02. Tech Spec for MB System-E,C&I Package:ROS:4140 Rev:00 Dt: 18.06.2016.<br>03.Approved Vendor list 4 WT 220 00488 REV 00<br>04. MB P&ID Drawing No.1-WT-220-00711,Rev:00,<br>05. Legend for P&ID Drawing No.2-WT-220-0211,Rev:01.<br>06. MB Equipment Layout Drawing No.1-WT-220-00712,Rev:00,<br>07.Painting Specification PRQA - 526,Rev:01,<br>08. Technical Annexure-B Mandatory Spares List<br>09. Qualification Requirement with Data Sheet - I & II<br>submit the same after necessary Filling,signing & returning a copy of the same. |                              |
| 02                                                 | SPECIFICATION                                     | Please confirm Clause wise / Point wise "IN TOTO" for all specifications and submit along with offer.                                                                                                                                                                                                                                                                                                                                                                                                                                                                                                                                                                                                                                                                                                                                    |                              |
| 03                                                 | DATA SHEETS / DRAWINGS                            | Filled Data Sheets and Drawings are to be submitted along with offer. ( if applicable )                                                                                                                                                                                                                                                                                                                                                                                                                                                                                                                                                                                                                                                                                                                                                  |                              |
| 04                                                 | QUALITY ASSURANCE PLAN (QAP)                      | To confirm applicable QAP will be followed. (OR) Supplier's Quality Plan to be submitted for our review and approval within 30 days from the date of Letter of Award (LOA).                                                                                                                                                                                                                                                                                                                                                                                                                                                                                                                                                                                                                                                              |                              |
| 05                                                 | SPECIFICATION DEVIATION DISPOSITION REPORT (SDDR) | Attached SDDR to be filled & submit along with offer. (Even, If NO deviation is taken, NIL report to be submitted).                                                                                                                                                                                                                                                                                                                                                                                                                                                                                                                                                                                                                                                                                                                      |                              |
| 06                                                 | COMMISSIONING SPARES                              | The commissioning spares List and the individual price should be indicated as per our Specification in the attached <b>ANNEXURE - C3</b><br><br>The Bidder should also indicate if any spare(s) other than those indicated in the spec is/are required for trouble free commissioning without additional cost if any,since the E&C,PG test & handing over is the supplier's scope.                                                                                                                                                                                                                                                                                                                                                                                                                                                       |                              |
| 07                                                 | MANDATORY SPARES                                  | The Mandatory spares List and the individual price should be indicated as per our Specification in the attached <b>ANNEXURE - C3</b>                                                                                                                                                                                                                                                                                                                                                                                                                                                                                                                                                                                                                                                                                                     |                              |
| <b>II</b> <u>Commercial Terms &amp; Conditions</u> |                                                   |                                                                                                                                                                                                                                                                                                                                                                                                                                                                                                                                                                                                                                                                                                                                                                                                                                          |                              |
| 01                                                 | PRICE                                             | Please confirm 'Firm Price' till completion of order                                                                                                                                                                                                                                                                                                                                                                                                                                                                                                                                                                                                                                                                                                                                                                                     |                              |
| 02                                                 | UNPRICED BID (PART-1)                             | Please confirm submission of 'Unpriced bid' in the price bid format attached duly signed.<br><br>SCANNED COPY of FILLED & SIGNED COPY OF 'Price Bid' format attached by filling all informations by writing 'Quoted' as the case may be in the 'Rate' and 'Value' columns to be submitted through E-Procurement System.                                                                                                                                                                                                                                                                                                                                                                                                                                                                                                                  |                              |
| 03                                                 | PRICED BID (PART-2)                               | Please confirm submission of 'Priced bid' in the price bid format attached duly signed.<br><br>SCANNED COPY of FILLED & SIGNED COPY OF 'Price Bid' format attached by filling all informations by writing the value as the case may be in the 'Rate' and 'Value' columns in a separate attachment to be submitted through E-Procurement System.                                                                                                                                                                                                                                                                                                                                                                                                                                                                                          |                              |

**ANNEXURE - B**  
**BHEL : BAP : RANIPET**  
**PURCHASE DESALINATION**  
**Commercial Terms and Conditions**  
**MIXED BED SYSTEM & ACCESSORIES FOR KPCL-YELAHANKA CCPP,370MW,RODM**  
**Enquiry No. 7760383E Dated 29/06/2016 Due Date 28/07/2016**

| Sl. No. | DESCRIPTION                               | BHEL (PURCHASER) REQUIREMENT                                                                                                                                                                                                                                                                                                                                                                                                                                                                                                                                        | VENDOR (SELLER) CONFIRMATION |
|---------|-------------------------------------------|---------------------------------------------------------------------------------------------------------------------------------------------------------------------------------------------------------------------------------------------------------------------------------------------------------------------------------------------------------------------------------------------------------------------------------------------------------------------------------------------------------------------------------------------------------------------|------------------------------|
| 04      | ORIGIN OF DESPATCH OF VARIOUS CONSIGNMENT | Please indicate clearly the origin of despatch of various consignments duly indicating whether interstate or intrastate based on the consignee address above. Origin of despatch should not be subjected to change during execution of contract.                                                                                                                                                                                                                                                                                                                    |                              |
| 05      | DELIVERY TERMS & PRICE BASIS              | Please confirm for FOR - Destination (KPCL CCPP, Yelahanka Site, Karnataka) basis.<br>Unloading the Material at site is under BHEL Scope.                                                                                                                                                                                                                                                                                                                                                                                                                           |                              |
| 06      | PACKING & FORWARDING                      | Please confirm inclusion of Packing & Forwarding Charges in the quoted price.                                                                                                                                                                                                                                                                                                                                                                                                                                                                                       |                              |
| 07      | FREIGHT & INSURANCE                       | Please confirm inclusion of Freight & Insurance Charges towards this in the quoted price.                                                                                                                                                                                                                                                                                                                                                                                                                                                                           |                              |
| 08      | EXCISE DUTY IN %<br>(For Supply)          | Please indicate Applicable or Not Applicable                                                                                                                                                                                                                                                                                                                                                                                                                                                                                                                        |                              |
|         |                                           | If applicable, please indicate the exact percentage applicable as on the date of submission of offer and also indicate whether the same is payable extra by BHEL or not.                                                                                                                                                                                                                                                                                                                                                                                            |                              |
|         |                                           | BHEL will provide the necessary exemption certificate from competent authorities and hence ED is not applicable. (Vendor to confirm availing of ED exemption). In order to get ED Exemption Certificate from the authority concerned by BHEL to match the delivery period, vendor has to provide their sub-vendor details WITH IN 45 DAYS after issue of PO.                                                                                                                                                                                                        |                              |
| 09      | SALES TAX / VAT IN %<br>(For Supply)      | Please clearly indicate the CST and VAT implication in the offer itself.<br>Please note the following.<br><b><u>1. Supplies from Seller's Works to KPCL CCPP, Yelahanka Site @ Karnataka</u></b><br><br>A) If Inter-state, CST is applicable under Section 6(2) of CST Act (Sale in transit E-I / E-II Sale). BHEL will provide the "C" Form & Vendor has to submit E-I form. Please Indicate the applicable CST %.<br><br>C) If Intra-state, VAT will be payable extra.<br>Please confirm that the your Billing will be done by "vendor's KARNATAKA Address" only. |                              |
|         |                                           | <b><u>2. Supplies from Seller's Sub-Vendor's Works to KPCL CCPP, Yelahanka Site @ Karnataka</u></b><br><br>A) If Inter-state, CST is exempted under Section 6(2) of CST Act (Sale in transit E-I / E-II Sale), BHEL will provide the "C" Form & Vendor has to submit E-II form.<br><br>C) If Intra-state, VAT will be payable extra.<br>Please confirm that the Billing will be done by "vendor's KARNATAKA Address" only for the dispatches of materials from Vendor's Sub-Vendor's KARNATAKA address.                                                             |                              |
| 10      | OCTROI                                    | Vendor price shall include octroi, as F.O.R Destination prices are quoted. As destination detail is given, vendor has to ascertain the applicability of octroi, if any.                                                                                                                                                                                                                                                                                                                                                                                             |                              |

**ANNEXURE - B**  
**BHEL : BAP : RANIPET**  
**PURCHASE DESALINATION**  
**Commercial Terms and Conditions**  
**MIXED BED SYSTEM & ACCESSORIES FOR KPCL-YELAHANKA CCPP,370MW,RODM**  
**Enquiry No. 7760383E Dated 29/06/2016 Due Date 28/07/2016**

| Sl. No. | DESCRIPTION                                                                                  | BHEL (PURCHASER) REQUIREMENT                                                                                                                                                                                                                                                                                                                                                                                                                                                                                                                                                                                                                                                                                                                                                                                                                                                                                                                                                                                                                                                                                                                                                                                                                                                                                                                                                                         | VENDOR (SELLER) CONFIRMATION |
|---------|----------------------------------------------------------------------------------------------|------------------------------------------------------------------------------------------------------------------------------------------------------------------------------------------------------------------------------------------------------------------------------------------------------------------------------------------------------------------------------------------------------------------------------------------------------------------------------------------------------------------------------------------------------------------------------------------------------------------------------------------------------------------------------------------------------------------------------------------------------------------------------------------------------------------------------------------------------------------------------------------------------------------------------------------------------------------------------------------------------------------------------------------------------------------------------------------------------------------------------------------------------------------------------------------------------------------------------------------------------------------------------------------------------------------------------------------------------------------------------------------------------|------------------------------|
| 11      | PAYMENT TERM FOR SUPPLY .<br><b>PLEASE CONFIRM TO SUBMIT E1/E2 FORM AGAINST FORM C FORM.</b> | <p>1. Eighty Five percent (85%) of basic price of materials supplied, as per approved billing schedule, along with 100% taxes and duties (as applicable), shall be paid against receipt of material at site and submission of Bank Guarantee for 10% of PO value valid till guarantee period towards performance before first submission of documents for payment.</p> <p>Validity of the Bank Guarantee shall be for the entire Guarantee period. Initially, it should be at least 18 months, later extended to cover the entire guarantee period, two months before its expiry.</p> <p>2. Five percent (5%) of basic price of materials supplied will be released after submission of Material Receipt Certificate (MRC) from project site engineer of Owner/ Purchaser and submission of Form E1/ E2 against Form-C, if applicable</p> <p>3. Balance Ten percent (10% ) of supply value after successful completion of erection, commissioning, PG Test and Handing over.</p> <p>PG Test to be conducted within 120 days from the date of Intimation by the vendor after successful completion of E&amp;C. However if BHEL delay the PG Test more than 120 days from the date of commissioning then BHEL will release the final 10% payment and subject to confirmation by the supplier that they will conduct PG Test immediately whenever there is a call from BHEL at the firmed up price.</p> |                              |
| 12      | CONFIRM THE PAYMENT TERM FOR SUPPLY, E&C and others if any.                                  | Differential Payments applicable for Supply, E&C and Others - Within 45 days for MSME & 90 days for Non MSME<br><b>Please confirm your status in case of MSME with relevant proof.</b>                                                                                                                                                                                                                                                                                                                                                                                                                                                                                                                                                                                                                                                                                                                                                                                                                                                                                                                                                                                                                                                                                                                                                                                                               |                              |
| 13      | ERECTION, COMMISSIONING & HANDING OVER                                                       | Please confirm the carrying out "ERECTION, COMMISSIONING, PG TEST & HANDING OVER " of <b>TOTAL MB SYSTEM</b> as per TECHNICAL SPECIFICATION <b>ROS:6154 Rev:00,</b>                                                                                                                                                                                                                                                                                                                                                                                                                                                                                                                                                                                                                                                                                                                                                                                                                                                                                                                                                                                                                                                                                                                                                                                                                                  |                              |
| 14      | CONSIGNEE ADDRESS<br>(Detailed TIN No etc., will be given later)                             | Please confirm supply to the following consignee address in the event of Order.<br><br><b>KPCL YELAHANKA CCPP (1x370MW)</b><br><b>SN Halli Post</b><br><b>YELAHANKA CCPP</b><br><b>(Dodaballapur-Benguluru State Highway)</b><br><b>Benguluru-560064 (Karnataka)</b><br><br><b>On account of M/s BHEL, BAP, Ranipet - 632 406</b>                                                                                                                                                                                                                                                                                                                                                                                                                                                                                                                                                                                                                                                                                                                                                                                                                                                                                                                                                                                                                                                                    |                              |
| 15      | CONDITION FOR E&C CHARGES                                                                    | Total erection & commissioning charges including service tax should be minimum 20% of the total quoted package price (including all taxes and freight), failing which the break-up of prices shall be adjusted accordingly for ordering.                                                                                                                                                                                                                                                                                                                                                                                                                                                                                                                                                                                                                                                                                                                                                                                                                                                                                                                                                                                                                                                                                                                                                             |                              |
| 16      | SERVICE TAX IN %<br>(For the Service Portions vide Enquiry Sl. No. 19 &20)                   | Please indicate the present applicable 'Service Tax' percentage for Seller Services. Please confirm / clearly indicate that the value on which the Service Tax is applicable in the Priced Price Bid'.                                                                                                                                                                                                                                                                                                                                                                                                                                                                                                                                                                                                                                                                                                                                                                                                                                                                                                                                                                                                                                                                                                                                                                                               |                              |
| 17      | PAYMENT TERM FOR ERECTION, COMMISSIONING & HANDING OVER.                                     | <p>(1) 70% payment with 100% Duties &amp; Taxes against completion of ERECTION OF THE TOTAL SYSTEM ON CERTIFICATION / PROTOCOL BY BHEL SITE OFFICIALS.</p> <p>(2) 20% payment after SUCCESSFUL COMMISSIONING OF THE TOTAL SYSTEM ON CERTIFICATION / PROTOCOL BY BHEL SITE OFFICIALS.</p> <p>(3) Balance 10% payment after SUCCESSFUL completion of PG Test &amp; HANDING OVER to BHEL SITE OFFICIALS and submission of BG for 10% of Order Value valid for 12 months from the date of PG TEST or OR 18 MONTHS FROM THE DATE OF COMPLETION OF E&amp;C</p> <p>However if BHEL delay the PG Test more than 120 days from the date of commissioning then BHEL will release the final 10% payment after receipt of BG for 10% of PO value and subject to confirmation by the supplier that they will conduct PG Test immediately whenever there is a call from BHEL at the firmed up price.</p>                                                                                                                                                                                                                                                                                                                                                                                                                                                                                                           |                              |

**ANNEXURE - B**  
**BHEL : BAP : RANIPET**  
**PURCHASE DESALINATION**  
**Commercial Terms and Conditions**  
**MIXED BED SYSTEM & ACCESSORIES FOR KPCL-YELAHANKA CCPP,370MW,RODM**  
**Enquiry No. 7760383E Dated 29/06/2016 Due Date 28/07/2016**

| Sl. No. | DESCRIPTION                                                                                                                                                                                | BHEL (PURCHASER) REQUIREMENT                                                                                                                                                                                                                                                                                                                                                                                                                                                                                                                                                                                                                                                    | VENDOR (SELLER) CONFIRMATION |
|---------|--------------------------------------------------------------------------------------------------------------------------------------------------------------------------------------------|---------------------------------------------------------------------------------------------------------------------------------------------------------------------------------------------------------------------------------------------------------------------------------------------------------------------------------------------------------------------------------------------------------------------------------------------------------------------------------------------------------------------------------------------------------------------------------------------------------------------------------------------------------------------------------|------------------------------|
| 18      | DELIVERY PERIOD FOR THE SUPPLY                                                                                                                                                             | Please confirm the supply completion on or before <b>24.01.2017 or 6 months from the date of LOA which ever is Later.</b><br><b>Submission/Resubmission of drg/doc as per drawing schedule enclosed with technical specification.</b><br>Vendor can also quote improved delivery date if any or otherwise, please clearly indicate the delivery period in weeks / months from the date of LOA. As there may be a chance to reject your offer based on quoted delivery period, request to confirm as per BHEL requirement.<br><br>Please note that the Delivery date will be the date of receipt of material at the consignee (Destination) place and not the LR/RR/AWB/BL Date. |                              |
| 19      | ERECTION, COMMISSIONING & HANDING OVER PERIOD                                                                                                                                              | Please confirm the completion of E&C Period within <b>12 Weeks</b> from the Supply PO Delivery date / Date of Site Readiness whichever is Later. Site Readiness will be informed by BHEL.<br><br>Please clearly indicate the E & C period in weeks / months from the date of Supply PO Delivery date / Date of Site Readiness whichever is Later.                                                                                                                                                                                                                                                                                                                               |                              |
| 20A     | LIQUIDATED DAMAGES (LD) - Supply Portion                                                                                                                                                   | Please confirm LD for delayed delivery of Equipment (as per IMPORTANT NOTE) @ 0.5% per week for the undelivered portion of the order value and maximum of 10% of the total contract value.                                                                                                                                                                                                                                                                                                                                                                                                                                                                                      |                              |
| 20B     | LIQUIDATED DAMAGES (LD) - E & C Portion                                                                                                                                                    | Please confirm LD for delayed ERECTION, COMMISSIONING & PG TEST of Equipment @ 0.5% per week and maximum of 10% of the total contract value.                                                                                                                                                                                                                                                                                                                                                                                                                                                                                                                                    |                              |
| 21      | OFFER VALIDITY                                                                                                                                                                             | Please confirm Offer Validity for a minimum period of 60 days from the date of price bid opening.                                                                                                                                                                                                                                                                                                                                                                                                                                                                                                                                                                               |                              |
| 22      | INSPECTION                                                                                                                                                                                 | Please confirm for 'Inspection' of all the Items by BHEL Engineers / BHEL Authorized Engineer and Customer / Consultant Engineer either jointly or individually before the dispatch of the item at vendor works as per approved QAP. Please note that no payment will be made by BHEL towards inspection.                                                                                                                                                                                                                                                                                                                                                                       |                              |
| 23      | TEST CERTIFICATE (TC)                                                                                                                                                                      | Please confirm that required TC will be provided at 'No Extra Cost'.                                                                                                                                                                                                                                                                                                                                                                                                                                                                                                                                                                                                            |                              |
| 24A     | GUARANTEE CERTIFICATE (GC) - Supply Portion.                                                                                                                                               | Please confirm furnishing of Guarantee certificate in BHEL format for 12 months from the date of commissioning or 18 months from the date of last despatch whichever is earlier.                                                                                                                                                                                                                                                                                                                                                                                                                                                                                                |                              |
| 24B     | GUARANTEE CERTIFICATE (GC) - E & C Portion                                                                                                                                                 | Please confirm furnishing of Guarantee certificate in BHEL format for the system for "12 MONTHS FROM THE DATE OF PG TEST OR 18 MONTHS FROM THE DATE OF COMPLETION OF E&C"                                                                                                                                                                                                                                                                                                                                                                                                                                                                                                       |                              |
| 25A     | <b>Contract Execution Bank Guarantee (CEBG).</b><br>Ple Ref: ANNEXURE –A GENERAL TERMS & CONDITIONS (FOR GUIDANCE TO THE SUPPLIERS) Under Clause -J]<br>Contract Execution Bank Guarantee: | To demonstrate the fidelity of the successful bidder, in executing the Contract, on receipt of the Letter of Intent / Purchase Order, the Supplier shall arrange to provide a contract execution bank guarantee (CEBG).                                                                                                                                                                                                                                                                                                                                                                                                                                                         |                              |
| 25B     | BANK GUARANTEE (BG) TOWARDS Supply Portion (10% OF ORDER VALUE)                                                                                                                            | BG to be submitted in the format issued by BHEL.<br>BG for 10% of the Total PO Value. Validity of the Bank Guarantee shall be for the entire Guarantee period. Initially, it should be at least 18 months, later extended to cover the entire guarantee period, two months before its expiry.                                                                                                                                                                                                                                                                                                                                                                                   |                              |
| 25C     | BANK GUARANTEE (BG) TOWARDS E & C Portion. (10% OF ORDER VALUE)                                                                                                                            | BG to be submitted in the format issued by BHEL.<br>BG for 10% of the Total PO Value valid for 12 months from the date of PG TEST OR 18 MONTHS FROM THE DATE OF COMPLETION OF E&C plus 3 months claim period.                                                                                                                                                                                                                                                                                                                                                                                                                                                                   |                              |
| 26      | ERECTION MANUAL (INSTALLATION INSTRUCTIONS)                                                                                                                                                | Please confirm for providing of 'comprehensive Erection Manual covering the entire supply which include bought-outs' 6 sets in Hard copy & one CD form.                                                                                                                                                                                                                                                                                                                                                                                                                                                                                                                         |                              |

**ANNEXURE - B**  
**BHEL : BAP : RANIPET**  
**PURCHASE DESALINATION**  
**Commercial Terms and Conditions**  
**MIXED BED SYSTEM & ACCESSORIES FOR KPCL-YELAHANKA CCPP,370MW,RODM**  
**Enquiry No. 7760383E Dated 29/06/2016 Due Date 28/07/2016**

| Sl. No. | DESCRIPTION                                                                                                                                                                                                                                                                        | BHEL (PURCHASER) REQUIREMENT                                                                                                                                                                                                                                                                                                                                                                                                                                             | VENDOR (SELLER) CONFIRMATION |
|---------|------------------------------------------------------------------------------------------------------------------------------------------------------------------------------------------------------------------------------------------------------------------------------------|--------------------------------------------------------------------------------------------------------------------------------------------------------------------------------------------------------------------------------------------------------------------------------------------------------------------------------------------------------------------------------------------------------------------------------------------------------------------------|------------------------------|
| 27      | O & M MANUAL                                                                                                                                                                                                                                                                       | Please confirm for providing of 'comprehensive O&M Manual covering the entire System' 6 sets in Hard copy & one CD form.                                                                                                                                                                                                                                                                                                                                                 |                              |
| 28      | REVERSE AUCTION                                                                                                                                                                                                                                                                    | Please see the Clause in the main enquiry regarding Reverse Auction (RA). RA will be conducted through our Service Provider. Vendor to confirm acceptance.                                                                                                                                                                                                                                                                                                               |                              |
|         |                                                                                                                                                                                                                                                                                    | Please note that in case BHEL decides not to conduct RA, the sealed price bids along with the impact price bids arising out of techno-commercial discussions already available with BHEL only will be opened. Please note that no impact price due to non-conductance of RA will be accepted. Vendor to confirm acceptance.                                                                                                                                              |                              |
| 29      | VENDOR'S SPECIFIC CONFIRMATION FOR ALL THE CLAUSES IN THE REVERSE SIDE OF THE ENQUIRY IF THE SAME ARE NOT COVERED SPECIFICALLY IN THESE COMMERCIAL TERMS AND CONDITIONS (LISTED) AND ARE ESSENTIAL FOR EXECUTION OF THE CONTRACT WHICH INCLUDE <b>RISK PURCHASE (CLAUSE No. 7)</b> | BHEL's Standard Risk Purchase clause will be applicable. Please confirm.                                                                                                                                                                                                                                                                                                                                                                                                 |                              |
| 30      | ZERO DATE (CONTRACT EFFECTIVE DATE)                                                                                                                                                                                                                                                | Please confirm for 'Date of LOA'.                                                                                                                                                                                                                                                                                                                                                                                                                                        |                              |
| 31      | Loading Criteria                                                                                                                                                                                                                                                                   | Please note that no Commercial deviation is acceptable to BHEL. In case any deviation is taken in any of the commercial terms such as Payment terms, LD, PBG, etc., where in we have specified the days, percentages etc., then loading will be done to the extent of the short fall with respect to the upper Limit specified for evaluation.<br><br>In respect of LD & PBG offers which do not accept for LD Clause & PBG would be summarly rejected - Please Confirm. |                              |
| 32      | NEGOTIATION                                                                                                                                                                                                                                                                        | In the event of negotiation if any, please confirm participation only by supplier's representative and not by their Agent which include indian Agent in the case of Foreign Offer.                                                                                                                                                                                                                                                                                       |                              |
| 33      | OTHER DOCUMENTS FOR APPROVAL (BBU)                                                                                                                                                                                                                                                 | In the event of order vendor should confirm the submission of BBU for the complete system supply with break up for each line item as well as quantities with value.                                                                                                                                                                                                                                                                                                      |                              |
| 34      | CONTACT PERSON'S DETAILS FOR CORRESPONDENCE: for the Commercial Terms & conditions queries confirmation.                                                                                                                                                                           | Name:<br>Designation:<br>Address:<br>Phone No.:<br>Mobile No.:<br>Fax No.:<br>E-mail ID:                                                                                                                                                                                                                                                                                                                                                                                 |                              |
| 35      | CONTACT PERSON'S DETAILS FOR CORRESPONDENCE: for the Technical Queries confirmation:                                                                                                                                                                                               | Name:<br>Designation:<br>Address:<br>Phone No.:<br>Mobile No.:<br>Fax No.:<br>E-mail ID:                                                                                                                                                                                                                                                                                                                                                                                 |                              |
| 36      | Please provide the statutory details:<br><b>Ple attach the PAN Card copy.</b>                                                                                                                                                                                                      | CST No :<br>TIN :<br>Tariff No. :<br>PAN No:                                                                                                                                                                                                                                                                                                                                                                                                                             |                              |
| 37      | <b>We have not taken cognizance of commercial terms mentioned any where else in your offer.</b><br><br><b>Commercial terms and conditions indicated in this Annexure - A will only be applicable and binding.</b>                                                                  | Acceptance Required                                                                                                                                                                                                                                                                                                                                                                                                                                                      |                              |

Signature, Seal & Date of offerer on all the pages.

**ANNEXURE - C1**  
**BHEL : BAP : RANIPET**  
**PURCHASE - DESALINATION**  
**PRICE OFFER FORMAT**  
**MIXED BED SYSTEM & ACCESSORIES FOR KPCL-YELAHANKA CCPP,370MW,RODM**  
**Enquiry No. 7760383E Dated 29/06/2016 Due Date 28/07/2016**

**PRICE OFFER - SUPPLY**

| <b>Enquiry Sl. No.</b> | <b>Description</b>                                                                                                                                                    | <b>Unit</b> | <b>Qty.</b> | <b>Rate / Unit in Rs.</b> | <b>Amount in Rs.</b> |
|------------------------|-----------------------------------------------------------------------------------------------------------------------------------------------------------------------|-------------|-------------|---------------------------|----------------------|
| 001                    | RWT603930001<br>MSRL DEGASSER TOWER WITH INTERNALS & ACCESSORIES.                                                                                                     | SET         | 1.00        |                           |                      |
| 002                    | RWT603930002<br>DEGASSER BLOWERS WITH MOTORS,DUCTS,SUCTION FILTERS, INLET AND OUTLET CONTROLS/VALVES & ACCESSORIES ETC AS PER THE TECH. SPECIFICATION ROS:6154 & 4140 | SET         | 2.00        |                           |                      |
| 003                    | RWT6039300003<br>MSRL DEGASSER WATER STORAGE TANK-20 M3 AND ACC.                                                                                                      | SET         | 1.00        |                           |                      |
| 004                    | RWT603930004<br>MIXED BED VESSEL WITH INTERNAL LATERALS AND ACCES SORIES.                                                                                             | SET         | 1.00        |                           |                      |
| 005                    | RWT603930005<br>MIXED BED (MB) FEED PUMPS WITH DRIVE MOTORS AND ALL ACCESSORIES.                                                                                      | SET         | 2.00        |                           |                      |
| 006                    | RWT603930006<br>MB REGENERATION PUMPS WITH DRIVE MOTORS AND ALL ACCESSORIES.                                                                                          | SET         | 2.00        |                           |                      |
| 007                    | RWT603930007<br>MB BLOWERS WITH DRIVE MOTORS & ACCE. AS PER TECH. SPECIFICATION.                                                                                      | SET         | 2.00        |                           |                      |
| 008                    | RWT603930008<br>ACID MEASURING TANK(AMT)- 1 NO. & CAUSTIC DILUTION TANKS(CDT)- 1 NOS. WITH AGITATOR, EJECTORS-02 NOS AND ACCESSORIES.                                 | SET         | 1.00        |                           |                      |
| 009                    | RWT603930009<br>MB SYSTEM FRONTAL PIPING(CPVC), WITH PENUMATIC OPERATED DIAPHRAGM VALVES ETC. AS PER THE TECH. SPECIFICATION.                                         | SET         | 1.00        |                           |                      |

**ANNEXURE - C1**  
**BHEL : BAP : RANIPET**  
**PURCHASE - DESALINATION**  
**PRICE OFFER FORMAT**  
**MIXED BED SYSTEM & ACCESSORIES FOR KPCL-YELAHANKA CCPP,370MW,RODM**  
**Enquiry No. 7760383E Dated 29/06/2016 Due Date 28/07/2016**

**PRICE OFFER - SUPPLY**

| <b>Enquiry Sl. No.</b> | <b>Description</b>                                                                                                                                                                                                                                          | <b>Unit</b> | <b>Qty.</b> | <b>Rate / Unit in Rs.</b> | <b>Amount in Rs.</b> |
|------------------------|-------------------------------------------------------------------------------------------------------------------------------------------------------------------------------------------------------------------------------------------------------------|-------------|-------------|---------------------------|----------------------|
| 010                    | RWT603930010<br>MB RESIN(CATION & ANION FOR 1 NO. OF MB VESSEL)                                                                                                                                                                                             | SET         | 1.00        |                           |                      |
| 011                    | RWT603930011<br>BULK CHEMICAL STORAGE SYSTEM CONSISTING OF : BULK ACID TANK(15 CU.M) & ACC. 01 SET, ACID UNLOADING PUMPS WITH MOTOR ASSY. - 02 NOS AND BULK ALKALI STORAGE TANK (15 CU.M) & ACC. 01 SET & ALKALI UNLOADING PUMPS WITH MOTOR ASSY. - 02 NOS. | SET         | 1.00        |                           |                      |
| 012                    | RWT603930012<br>INTERCONNECTING PIPING(UPVC/CPVC)BETWEEN EQUIPMENT& VALVES & ACCESSORIES, BULK STORAGE SYSTEM(CPVC) & DISTRIBUTION AS PER THE TECH. SPECIFICATION.                                                                                          | SET         | 1.00        |                           |                      |
| 013                    | RWT603930013<br>FOUNDATION BOLTS, APPLICABLE FASTENERS, GASKETS, LADDERS, PLATFORM FOR MB, SUPPORTS(FOR PIPING & VALVES) AND MISCELLANEOUS.                                                                                                                 | SET         | 1.00        |                           |                      |
| 014                    | RWT603930014<br>N-PIT EFFLUENT TRANSFER PUMP WITH MOTOR ASSY & ACCAS PER TECHNICAL SPECIFICATION.                                                                                                                                                           | SET         | 2.00        |                           |                      |
| 015                    | RWT603930015<br>PRIMING CHAMBER ASSY. WITH ACCESSORIES FOR N-PIT EFFLUENT TRANSFER PUMP AS PER P&ID AND TECHNICAL SPECIFICATION.                                                                                                                            | SET         | 2.00        |                           |                      |
| 016                    | RWT603930016<br>DIFFUSER PIPING ARRANGEMENT FOR FOR N-PIT AS PER TECH. SPECIFICATION.                                                                                                                                                                       | SET         | 1.00        |                           |                      |
| 017                    | RWT603930017<br>VALVES ( MANUAL BFV, DIAPHRAGM, BALL VALVE & AUTO PNEUMATIC OPERATED DIAPHRAGM VALVES) AS PER THE TECH. SPECIFICATION.                                                                                                                      | SET         | 1.00        |                           |                      |

**ANNEXURE - C1**  
**BHEL : BAP : RANIPET**  
**PURCHASE - DESALINATION**  
**PRICE OFFER FORMAT**  
**MIXED BED SYSTEM & ACCESSORIES FOR KPCL-YELAHANKA CCPP,370MW,RODM**  
**Enquiry No. 7760383E Dated 29/06/2016 Due Date 28/07/2016**

**PRICE OFFER - SUPPLY**

| Enquiry Sl. No.                                            | Description                                                                                                                       | Unit | Qty. | Rate / Unit in Rs. | Amount in Rs. |
|------------------------------------------------------------|-----------------------------------------------------------------------------------------------------------------------------------|------|------|--------------------|---------------|
| 018                                                        | <i>RWT603930018<br/>ELECTRICALS, CONTROLS &amp; INSTRUMENTATIONS AS PER TECH. SPEC. NO. ROS:4140 AND P&amp;ID.</i>                | SET  | 1.00 |                    |               |
| 021                                                        | <i>RWT603930021<br/>MANDATORY SPARES (MECH. &amp; E C&amp;I) AS PER TECH. SPEC. ROS:6154 &amp; 4140.<br/>AS PER ANNEXURE - C3</i> | SET  | 1.00 |                    |               |
| <b>Total Price (Total of Sl. No. 001 to 018 &amp; 021)</b> |                                                                                                                                   |      |      |                    |               |

**IMPORTANT NOTES**

- 1) All the Items are to be inspected by BHEL Engineers / BHEL Authorized Engineer and Customer / Consultant Engineer either jointly or individually before the despatch of the item at vendor works as per approved QAP.
- 2) All Items will be compared on SET Basis & Order will be placed on a Single vendor who is the lowest (L1) on set basis.
- 3) Please confirm the supply completion with in 24.01.2017 or 6 months from the date of LOA which ever is Later. Submission/Resubmission of drg/doc as per drawing schedule enclosed with technical specification.,
- 4) Vendor can also quote improved delivery date if any from the date of LOA,
- 5) Since E&C is at Vendor scope, Commissioning Spares requirement to be taken care by the Vendor along with main supply with out any extra cost.

**Signature & Seal of Offerer**

**ANNEXURE - C2**  
**BHEL : BAP : RANIPET**  
**PURCHASE - DESALINATION**  
**PRICE OFFER FORMAT**  
**MIXED BED SYSTEM & ACCESSORIES FOR KPCL-YELAHANKA CCPP,370MW,RODM**  
**Enquiry No. 7760383E Dated 29/06/2016 Due Date 28/07/2016**

**PRICE OFFER - SERVICE**

| Enquiry Sl. No.                        | Description                                                                                                                                                                                                                                                                                                                                                                                                                                                                                                                                                                                                                                                                                                                                                                                                  | Unit    | Qty. | Rate / Unit in Rs. | Amount in Rs. |
|----------------------------------------|--------------------------------------------------------------------------------------------------------------------------------------------------------------------------------------------------------------------------------------------------------------------------------------------------------------------------------------------------------------------------------------------------------------------------------------------------------------------------------------------------------------------------------------------------------------------------------------------------------------------------------------------------------------------------------------------------------------------------------------------------------------------------------------------------------------|---------|------|--------------------|---------------|
| 019                                    | <i>RWT603930019<br/>COLLECTION OF MATERIAL FROM SITE STORE, ERECTION, COMMISSIONING &amp; PG TEST OF THE MB SYSTEM.</i>                                                                                                                                                                                                                                                                                                                                                                                                                                                                                                                                                                                                                                                                                      | SET     | 1.00 |                    |               |
| 020                                    | <i>RWT603930020<br/>TRIAL OPERATION OF THE MB SYSTEM FOR ONE MONTH PERIOD AFTER THE COMMISSIONING PROTOCOL.</i>                                                                                                                                                                                                                                                                                                                                                                                                                                                                                                                                                                                                                                                                                              | SET     | 1.00 |                    |               |
|                                        | <b>Total Price (Total of Sl. No. 019-020)</b>                                                                                                                                                                                                                                                                                                                                                                                                                                                                                                                                                                                                                                                                                                                                                                |         |      |                    |               |
| OPTIONAL PRICE                         | Recommended Spares for 3 years O&M -List of Spares with Price breakupto be furnished. Note: This item will be ordered if required only and this item will not be considered for arriving RANKING                                                                                                                                                                                                                                                                                                                                                                                                                                                                                                                                                                                                             | SET     | 1.00 |                    |               |
| OPTIONAL PRICE                         | DIEM charges for the Trial Operation beyond 1 month on Pro rata basis. (This will be operated if required only)                                                                                                                                                                                                                                                                                                                                                                                                                                                                                                                                                                                                                                                                                              | Per Day | 1.00 |                    |               |
| <b>IMPORTANT NOTES</b>                 | <p>1) All Items will be compared on SET Basis &amp; Order will be placed on a Single vendor who is the lowest (L1) on set basis</p> <p>2)Please confirm the completion of E&amp;C Period within 12 Weeks from the Supply PO Delivery date / Date of Site Readiness whichever is Later. Site Readiness will be informed by BHEL.</p> <p>3) Since E&amp;C is at Vendor scope, Commissioning Spares requirement to be taken care by the Vendor along with main supply with out any extra cost.</p> <p style="text-align: right;">4) Please</p> <p><b>Note: Total erection &amp; commissioning charges including service tax should be minimum 20% of the total quoted package price (including all taxes and freight), failing which the break-up of prices shall be adjusted accordingly for ordering.</b></p> |         |      |                    |               |
| <b>Signature &amp; Seal of Offerer</b> |                                                                                                                                                                                                                                                                                                                                                                                                                                                                                                                                                                                                                                                                                                                                                                                                              |         |      |                    |               |

**ANNEXURE - C3**  
**BHEL : BAP : RANIPET**  
**PURCHASE - DESALINATION**  
**PRICE OFFER FORMAT**  
**MIXED BED SYSTEM & ACCESSORIES FOR KPCL-YELAHANKA CCPP,370MW,RODM**  
**Enquiry No. 7760383E Dated 29/06/2016 Due Date 28/07/2016**

**COMMISSIONING SPARES & MANDATORY SPARES FOR MB SYSTEM-KPCL YELAHANKA CCPP,370MW,RODM.**  
**MB System-Mech : ROS 6154 Rev:00,18.06.2016**  
**MB System-E,C&I Package:ROS: 4140 Rev: 00**

**MB SYSTEM - COMMISSIONING SPARES TENTATIVE**

| Sl No                                                | Description                                                                                                                       | Type of Spare          | Qty                   | Unit | Rate per Unit | Total Value | Remarks |
|------------------------------------------------------|-----------------------------------------------------------------------------------------------------------------------------------|------------------------|-----------------------|------|---------------|-------------|---------|
| <b>COMMISSIONING SPARES - MECHANICAL</b>             |                                                                                                                                   |                        |                       |      |               |             |         |
| 1                                                    | MB vessel                                                                                                                         | Filter nozzles         | 10% of total Qty.     | Set  |               |             |         |
| 2                                                    | AMT / CDT Ejector                                                                                                                 | Ejector nozzle         | 1.00                  | Set  |               |             |         |
|                                                      | Since E&C is your scope,plan in advance for other additional spares required for Mech,hence requested to add the rows suitably.   |                        |                       |      |               |             |         |
| <b>Total Price</b>                                   |                                                                                                                                   |                        |                       |      |               |             |         |
| <b>COMMISSIONING SPARES - E, C &amp; I</b>           |                                                                                                                                   |                        |                       |      |               |             |         |
| 1                                                    | pH sensor                                                                                                                         |                        | 1                     | No   |               |             |         |
| 2                                                    | Density indicator                                                                                                                 |                        | 1                     | No   |               |             |         |
|                                                      | Since E&C is your scope,plan in advance for other additional spares required for E,C&I ,hence requested to add the rows suitably. |                        |                       |      |               |             |         |
| <b>Total Price</b>                                   |                                                                                                                                   |                        |                       |      |               |             |         |
| <b>MB SYSTEM - MANDATORY SPARES - (RWT603930021)</b> |                                                                                                                                   |                        |                       |      |               |             |         |
| <b>MANDATORY SPARES - MECHANICAL</b>                 |                                                                                                                                   |                        |                       |      |               |             |         |
| Sl No                                                | Description                                                                                                                       | Type of Spare          | Qty                   | Unit | Rate per Unit | Total Value | Remarks |
| 1                                                    | Degasser tower                                                                                                                    | Pall rings             | 10% of total quantity |      |               |             |         |
|                                                      |                                                                                                                                   | Fill support members   | 10% of total quantity |      |               |             |         |
|                                                      |                                                                                                                                   | Water sealing fittings | 10% of total quantity |      |               |             |         |
| 2                                                    | Degasser blower                                                                                                                   | Blades/Impeller        | 2                     | Set  |               |             |         |
|                                                      |                                                                                                                                   | Shaft                  | 2                     | Set  |               |             |         |
|                                                      |                                                                                                                                   | Blower bearings        | 2                     | Set  |               |             |         |

**ANNEXURE - C3**  
**BHEL : BAP : RANIPET**  
**PURCHASE - DESALINATION**  
**PRICE OFFER FORMAT**  
**MIXED BED SYSTEM & ACCESSORIES FOR KPCL-YELAHANKA CCPP,370MW,RODM**  
**Enquiry No. 7760383E Dated 29/06/2016 Due Date 28/07/2016**

**COMMISSIONING SPARES & MANDATORY SPARES FOR MB SYSTEM-KPCL YELAHANKA CCPP,370MW,RODM.**  
**MB System-Mech : ROS 6154 Rev:00,18.06.2016**  
**MB System-E,C&I Package:ROS: 4140 Rev: 00**

|   |                           |                         |                                      |     |  |  |                                                |
|---|---------------------------|-------------------------|--------------------------------------|-----|--|--|------------------------------------------------|
| 3 | Mixed Bed unit            | Resin                   | 10% of total quantity cation & anion |     |  |  | Min. 40 ltrs cation & Min. 70 ltrs Anion resin |
|   |                           | Laterals                | 10% of total quantity                |     |  |  |                                                |
|   |                           | Strainers/Filter nozzle | 10% of total quantity                |     |  |  |                                                |
| 4 | Acid unloading pump       | Impeller                | 1                                    | No  |  |  |                                                |
|   |                           | Shafts                  | 1                                    | No  |  |  |                                                |
|   |                           | Bearings                | 1                                    | Set |  |  |                                                |
|   |                           | Shaft sleeves           | 1                                    | Set |  |  |                                                |
|   |                           | Bearing bushings        | 1                                    | Set |  |  |                                                |
|   |                           | Mechanical seal         | 1                                    | Set |  |  |                                                |
|   |                           | Wearing rings           | 1                                    | Set |  |  |                                                |
|   |                           | Fasteners               | 1                                    | Set |  |  |                                                |
| 5 | Alkali unloading pumps    | Impeller                | 1                                    | No  |  |  |                                                |
|   |                           | Shafts                  | 1                                    | No  |  |  |                                                |
|   |                           | Bearings                | 1                                    | Set |  |  |                                                |
|   |                           | Shaft sleeves           | 1                                    | Set |  |  |                                                |
|   |                           | Bearing bushings        | 1                                    | Set |  |  |                                                |
|   |                           | Mechanical seal         | 1                                    | Set |  |  |                                                |
|   |                           | Wearing rings           | 1                                    | Set |  |  |                                                |
|   |                           | Fasteners               | 1                                    | Set |  |  |                                                |
| 6 | Neutralizing system pumps | Impeller                | 1                                    | No  |  |  |                                                |
|   |                           | Shafts                  | 1                                    | No  |  |  |                                                |
|   |                           | Bearings                | 1                                    | Set |  |  |                                                |
|   |                           | Shaft sleeves           | 1                                    | Set |  |  |                                                |
|   |                           | Bearing bushings        | 1                                    | Set |  |  |                                                |
|   |                           | Mechanical seal         | 1                                    | Set |  |  |                                                |
|   |                           | Wearing rings           | 1                                    | Set |  |  |                                                |
|   |                           | Fasteners               | 1                                    | Set |  |  |                                                |

**ANNEXURE - C3**  
**BHEL : BAP : RANIPET**  
**PURCHASE - DESALINATION**  
**PRICE OFFER FORMAT**  
**MIXED BED SYSTEM & ACCESSORIES FOR KPCL-YELAHANKA CAPP,370MW,RODM**  
**Enquiry No. 7760383E Dated 29/06/2016 Due Date 28/07/2016**

**COMMISSIONING SPARES & MANDATORY SPARES FOR MB SYSTEM-KPCL YELAHANKA CAPP,370MW,RODM.**  
**MB System-Mech : ROS 6154 Rev:00,18.06.2016**  
**MB System-E,C&I Package:ROS: 4140 Rev: 00**

|                                        |                                                    |                      |             |             |                      |                    |                |
|----------------------------------------|----------------------------------------------------|----------------------|-------------|-------------|----------------------|--------------------|----------------|
| 7                                      | DM Regeneration pump                               | Impeller             | 1           | No          |                      |                    |                |
|                                        |                                                    | Shafts               | 1           | No          |                      |                    |                |
|                                        |                                                    | Bearings             | 1           | Set         |                      |                    |                |
|                                        |                                                    | Shaft sleeves        | 1           | Set         |                      |                    |                |
|                                        |                                                    | Bearing bushings     | 1           | Set         |                      |                    |                |
|                                        |                                                    | Mechanical seal      | 1           | Set         |                      |                    |                |
|                                        |                                                    | Wearing rings        | 1           | Set         |                      |                    |                |
|                                        |                                                    | Fasteners            | 1           | Set         |                      |                    |                |
| 8                                      | Mixed Bed Feed pumps                               | Impeller             | 1           | No          |                      |                    |                |
|                                        |                                                    | Shafts               | 1           | No          |                      |                    |                |
|                                        |                                                    | Bearings             | 1           | Set         |                      |                    |                |
|                                        |                                                    | Shaft sleeves        | 1           | Set         |                      |                    |                |
|                                        |                                                    | Bearing bushings     | 1           | Set         |                      |                    |                |
|                                        |                                                    | Mechanical seal      | 1           | Set         |                      |                    |                |
|                                        |                                                    | Wearing rings        | 1           | Set         |                      |                    |                |
|                                        |                                                    | Fasteners            | 1           | Set         |                      |                    |                |
| <b>Total Price</b>                     |                                                    |                      |             |             |                      |                    |                |
| <b>MANDATORY SPARES - E, C &amp; I</b> |                                                    |                      |             |             |                      |                    |                |
| <b>Sl No</b>                           | <b>Type of Spare</b>                               | <b>Type of Spare</b> | <b>Unit</b> | <b>Unit</b> | <b>Rate per Unit</b> | <b>Total Value</b> | <b>Remarks</b> |
| 1                                      | Air filter regulator                               |                      | 1           | No          |                      |                    |                |
| 2                                      | Pressure Indicating transmitter (PIT)              |                      | 1           | No          |                      |                    |                |
| 3                                      | Level transmitter                                  |                      | 1           | No          |                      |                    |                |
| 4                                      | Flow Indicating Transmitter (FIT) & orifice plates |                      | 1           | No          |                      |                    |                |
| 5                                      | Differential Pressure Switch (DPS)                 |                      | 1           | No          |                      |                    |                |
| 6                                      | Conductivity Analyser (complete set with sensor).  |                      | 1           | No          |                      |                    |                |
| 7                                      | PH Analyser (complete set with sensor).            |                      | 1           | No          |                      |                    |                |
| 8                                      | pH sensor (additional)                             |                      | 1           | No          |                      |                    |                |
| <b>Total Price</b>                     |                                                    |                      |             |             |                      |                    |                |

**ANNEXURE - D  
SPECIFICATION DEVIATION DISPOSITION REPORT**

|                                                           |                                                                   |             |
|-----------------------------------------------------------|-------------------------------------------------------------------|-------------|
| Enquiry No. 7760383E Dated 29/06/2016 Due Date 28/07/2016 | MIXED BED SYSTEM & ACCESSORIES FOR KPCL-YELAHANKA CCPP,370MW,RODM | Vendor Name |
|-----------------------------------------------------------|-------------------------------------------------------------------|-------------|

01. Technical Specification for MB System-: ROS 6154 Rev:00,Dt:18.06.2016.  
 01A . Tech Spec ROS:6154,Rev:00-for E&C,PG Test & Handing Over.  
 02. Tech Spec for MB System-E,C&I Package:ROS:4140 Rev:00 Dt: 18.06.2016.  
 03.Approved Vendor list 4 WT 220 00488 REV 00  
 04. MB P&ID Drawing No.1-WT-220-00711,Rev:00,  
 05. Legend for P&ID Drawing No.2-WT-220-0211,Rev:01.  
 06. MB Equipment Layout Drawing No.1-WT-220-00712,Rev:00,  
 07.Painting Specification PRQA - 526,Rev:01,  
 08. Technical Annexure-B Mandatory Spares List  
 09. Qualification Requirement with Data Sheet - I & II

| Page | Clause | Details Of Deviation With Reason | Disposition By BHEL |
|------|--------|----------------------------------|---------------------|
|      |        |                                  |                     |

|                                                            |                      |             |
|------------------------------------------------------------|----------------------|-------------|
| Signature Of Vendor                                        | " AGREED DEVIATION " | Reviewed By |
| if any to be incorporated in the PO in the event of order. |                      | APPROVED BY |

Date :

VENDOR's SIGNATURE WITH SEAL

*(TO BE STAMPED IN ACCORDANCE WITH STAMP ACT AND THE EXPIRY DATE OF BG MUST BE AFTER 3 MONTHS FROM THE DATE OF COMPLETION OF SUPPLIES)*

**CONTRACT EXECUTION BANK GUARANTEE**

In accordance of M/s. Bharat Heavy Electricals Limited (A Government of India undertaking, a company incorporated under the Companies Act 1956 having its Registered Office at "BHEL House", SIRI Fort, New Delhi 110 049) through its Boiler Auxiliaries Plant located at Ranipet – 632 406, (hereinafter called 'the Company') having entered into a contract with M/s.....  
..... hereinafter called 'the said contractor' which term includes 'suppliers' for the purpose of this Bond and under the terms and conditions of the Contract No.....Dt.....between BHEL, Ranipet and as per the Contract, the Contractor / Supplier is to furnish a Contract Execution Bank Guarantee for Rs.....in words.....  
.....for the due performance of the contract and for the fulfillment of all the terms and conditions of the contract.

Sign and seal of issuing bank  
Please affix Non Judicial Stamp  
here, as per Stamp Act

Bank Guarantee No.....Date.....Banker Name.....  
Bank Guarantee Value Rs.....

1. We.....  
.....  
.....(Bank's name, Branch, Place – address to be mentioned [herein after referred to as the Bank) at the request of.....  
.....(Contractor(s)] do hereby undertake to pay the company an amount not exceeding Rs.....in words  
.....  
.....against any loss or damage caused to or suffered or would be caused to or suffered by the company by reason of any breach by the said Contractor(s) of any of the terms and conditions contained in the said agreement.

2. We.....  
.....  
.....(name of the bank with full address), do hereby undertake to pay the amounts due and payable under this guarantee without any demur, merely on a demand from the Company stating that the amount claimed is due by way of loss or damage caused to or would be caused to or suffered by the Company by reason of breach by the said Contractor(s) of any of the terms and conditions contained in the said Agreement or by the reason of the Contractor(s) 'failure to perform' the said agreement. Any such demand made on the Bank shall be conclusive as regards the amount due and payable by the Bank under this guarantee. However, our liability under this guarantee shall be restricted to an amount not exceeding Rs.....in words.....

Sign and seal of issuing bank

Bank Guarantee No.....Date.....Banker Name.....  
Bank Guarantee Value Rs.....

3. We undertake to pay conditionally to the Company any money so demanded notwithstanding any dispute(s) raised by the Contractor in any suit, or proceedings pending before any Court or Tribunal or Arbitration or before any other authority relating thereto our liability under this present being absolute and unequivocal. The payment under this guarantee would not wait till the disputes have been decided by any Court or Tribunal or in the arbitration proceedings or by any other authority. The payment so made by us under this Bond shall be a valid discharge of liability for payment thereunder and the Contractor(s) shall have no claim against us for making such payment.

4. We.....(name of Bank), further agree that the guarantee herein contained shall remain in full force and effect during the period that would be taken for the performance of the said Agreement and that it shall continue to be enforceable till all the dues of the Company under or by virtue of the said Agreement have been fully paid and its claims satisfied or discharged or till Purchase Department of the Company certifies that the terms and conditions of the said Agreement have been fully and properly carried out by the said Contractor(s) and accordingly discharges this guarantee.

5. (i) Unless a demand or claim under this guarantee is made on us in writing on or before .....(date) (After 3 months from the date of completion of supplies) we shall be discharged from all the liability under this guarantee thereafter. But where such claim or demand has been preferred by the Company with the Bank before the expiry of the said date, the claim shall be enforceable notwithstanding the fact that the said enforcement is effected after the said date. (ii) For the purpose of this clause, any letter making demand on the Bank by M/s. BHEL dispatched by Registered Post with Ack. Due or by Telegram or by any Electronic media addressed to the above mentioned address of the Bank shall be deemed to be the claim / demand in writing referred to above irrespective of the fact as to whether and when the said letter reaches the Bank, as also any letter containing the said demand or claim is lodged with the Bank personally.

Sign and seal of issuing bank

Bank Guarantee No.....Date.....Banker Name.....  
Bank Guarantee Value Rs.....

6. We.....(name of the Bank), further agree with the company that the Company shall have the fullest liberty without our consent and without affecting in any manner our obligations hereunder to vary any of the terms and conditions of the said agreement or to extend time of performance by the said Contractor(s) from time to time or to postpone for any time or from time to time any of the powers exercisable by the Company against the said Contractor(s) and to forbear or enforce any of the terms and conditions relating to the said Agreement and we shall not be relieved from our liability by any reason of any such variation or extension being granted to the said Contractor(s) or for any forbearance, act or omission on the part of the company or any indulgence by the company to the said Contractor(s) or by any such matter or thing whatsoever which under the law relating would, but for this provision, have effect of not so relieving us.

7. This guarantee will not be discharged due to the change in the constitution of the Bank or the Contractor(s).

8. The guarantee herein contained shall not be determined or affected by the liquidation or winding up or insolvency of or change in the constitution of the Contractor, but shall in all respects and for all purpose be binding and operative until all payments of all moneys due or that may hereafter become due to the said company or settled irrespective of any liability or obligation of the Contractor under the said Contract.

9. It shall not be necessary for the company to proceed against the Contractor before proceeding against the guarantor-bank and the guarantee herein contained shall be enforceable against them notwithstanding any security, which the company may have obtained from the Contractor shall, at the time when proceedings are taken against the Guarantor hereunder be outstanding or unrealized.

10. Any claim or dispute arising under the terms of this document shall only be enforced or settled in the Courts at Ranipet, Tamilnadu Jurisdiction.

11. The Bank declares that it has powers to issue this Guarantee under the Bank's Memorandum and Articles of Association and the undersigned has full powers to do so on its behalf under the power granted to him by the proper authorities of the Bank.

12. We .....(name of Bank) lastly undertake not to revoke this guarantee during its currency except with the previous consent of the company in writing.

In witness whereof we.....  
(name of Bank) have hereunto setout Bank Seal the.....  
day of.....month 20\_\_.

Sign and seal of issuing bank.

## **Online SRF Submission Procedure**

Following are the formalities to be completed by your company for registration purpose.

**NOTE: BEFORE PROCEEDING FOR ONLINE REGISTRATION " PLS READ STEPS FOR FILLING UP ONLINE REGISTRATION FORM - HELP MENU" - DETAILS ATTACHED WITH THIS MAIL**

With effect from 01.04.2015 onwards, we have migrated to online Supplier Registration Form (SRF) as per our Corporate guidelines. **Supplier Registration Form (SRF)** is to be fed in our BHEL website portal – **ie., PDF documents of SRF and its annexure as called for shall be signed by authorized signatory & uploaded in portal.**

We request to visit our Web Site : [www.bhel.com](http://www.bhel.com) and click under heading "Supplier Registration" and fill up the **"Supplier Registration Form"** which is available in the Online Supplier Registration Portal.

Or else, copy the following URL Link and paste in the web link address: [http://www.bhel.com/vender\\_registration/vender.php](http://www.bhel.com/vender_registration/vender.php) and proceed with.

Or else, type directly as <http://203.129.195.108>

**Click the button "search material"** on the home page of supplier registration portal and search thoroughly your required material / product

*After completing the material search then proceed for User Id & Password for filling up the details of registration requirements. **Note: If you are an already registered supplier with any of our BHEL Unit - pls select "existing permanent supplier" or else select "New Registration" and then proceed accordingly.***

**Please note that for a foreign suppliers' there is a separate format to be filled in, which may be taken care suitably.**

After successful submission of SRF along with all annexures as called for thro' online i.e., authorized signatory signed pdf documents of SRF and its annexures are to be uploaded thro' online portal and confirm the same in **"form dispatch"** area ie., registration part-4 – wherein supplier has to confirm that all the documents were submitted "online" and click the button **"confirm"**. After clicking confirmation button, the same will be appearing against BHEL Ranipet for registration.

Looking for a long successful & sustaining business association with BHEL.



SPECIFICATION FOR  
MIXED BED SYSTEM

SPEC. No:ROS-6154

REV: 00

**BHARAT HEAVY ELECTRICALS LIMITED,  
RANIPET- 632 406.**

**TECHNICAL SPECIFICATION**

**FOR**

**MIXED BED SYSTEM**

**For KPCL- Yelahanka**

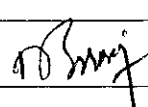
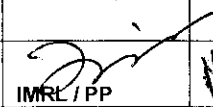
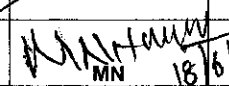
|        |          |                                                                                         |                                                                                                  |                                                                                                       |             |
|--------|----------|-----------------------------------------------------------------------------------------|--------------------------------------------------------------------------------------------------|-------------------------------------------------------------------------------------------------------|-------------|
|        |          |                                                                                         |                                                                                                  |                                                                                                       |             |
|        |          |                                                                                         |                                                                                                  |                                                                                                       |             |
|        |          |                                                                                         |                                                                                                  |                                                                                                       |             |
|        |          |                                                                                         |                                                                                                  |                                                                                                       |             |
|        |          |                                                                                         |                                                                                                  |                                                                                                       |             |
| 00     | 18.06.16 | DBN  | <br>IMRL / PP | <br>MN<br>18/6/16 | Fresh issue |
| Rev.No | Date     | Prepared                                                                                | Checked                                                                                          | Approved                                                                                              | Remarks     |

|                                                                                   |                                               |                   |
|-----------------------------------------------------------------------------------|-----------------------------------------------|-------------------|
|  | <b>SPECIFICATION FOR<br/>MIXED BED SYSTEM</b> | SPEC. No:ROS-6154 |
|                                                                                   |                                               | REV: 00           |

## 1.0 SCOPE OF SUPPLY & SERVICES

1.1 The intent of this specification is to cover Design, Engineering, Manufacturing, Shop Testing, Supply, Transportation, Erection & Commissioning, trial operation for the period of one month from the date of commissioning protocol and Performance Guarantee Test (PG Test) and handing over of the following systems.

- **DE-GASSER SYSTEM**
- **MIXED BED (MB) SYSTEM**
- **MB REGENERATION SYSTEM**
- **BULK STORAGE SYSTEM**
- **N-PIT EFFLUENT DISPOSAL SYSTEM**

The scope shall fully cover the requirement of the Design Criteria and Technical requirement of this specification for treating the permeate water from Reverse Osmosis (RO) Stage-II to meet the boiler makeup water quality requirement. The scope shall include but not limited to the following

- a. 1 x 100% MSRL Degasser tower with all internals & accessories
- b. 1 x 100% MSRL Degassed Water Storage Tank.
- c. 2 x 100% (1W + 1S) of Degasser Blowers with motors, Air filter box (suction) & accessories
- d. 1 x 100% (1W) MB Unit along with all accessories, internals etc.,
- e. 1 set of Cat ion & anion resin for MB system
- f. 2 x 100 % (1W+1S) Mixed Bed (MB) feed pumps with motors and all accessories.
- g. 2 x 100% (1W+1S) MB regeneration Pumps with motors and all accessories
- h. 2 x 100% (1W+1S) MB Blowers with motors and all accessories for MB regeneration
- i. 1 x 100% Acid Measuring Tank (AMT), ejector & acc. etc for MB regeneration
- j. 1 x 100% Caustic Dilution Tank (CDT) with agitator, ejector & acc. etc. for MB regeneration.
- k. 1 x 100% Bulk Acid Storage Tank (MSRL) with 2 x 100% acid unloading pumps with motors along with interconnecting piping & accessories.
- l. 1 x 100% Bulk Caustic Storage Tank with 2 x 100% caustic unloading pumps with motors along with interconnecting piping & accessories.
- m. 1 set of MB frontal piping (CPVC) with pneumatic operated diaphragm valves.
- n. 1 set of interconnecting piping/ducting system including valves and accessories etc. for the following areas as per the **enclosed P &ID**.
  - Degasser system to MB feed pumps
  - Degasser blowers to degasser(ducting)
  - MB feed pumps to MB vessel
  - MB blowers to MB vessel
  - MB regeneration pumps suction piping from DM Water storage tank upto pumps

|                                                                                   |                                               |                   |
|-----------------------------------------------------------------------------------|-----------------------------------------------|-------------------|
|  | <b>SPECIFICATION FOR<br/>MIXED BED SYSTEM</b> | SPEC. No:ROS-6154 |
|                                                                                   |                                               | REV: 00           |

- MB regeneration pumps discharge to MB system
  - Piping for bulk chemical storage system (unloading pumps to tanks & from tanks to AMT/CDT)
  - Bulk chemical storage system to Neutralization pit.
  - AMT/CDT area to MB system.
  - MB outlet piping from vessel to outside of RO-DM plant building.
  - Between N.pit, priming chamber, N.pit effluent transfer pumps and discharge piping till the terminal point.
- o. 2 x 100% (1W+1S) N-pit effluents transfer pumps with motors and all accessories
- p. 2x100% (1W+1S) priming chamber for above N-pit transfer pump & diffuser piping arrangement for N-pit with all accessories
- q. 1 set of necessary foundation bolts, applicable fasteners, gaskets, ladders, flat form for MB, supports (for piping & valves) and miscellaneous (safety showers – 03 nos. etc.).
- r. 1 set of Electrical, Controls & Instrumentation as per specification & PID & ROS: 4041

The permeate water from RO 2<sup>nd</sup> stage shall be degasified in the Degasser tower (DGT) and stored in a Degassed water storage tank (DWST). The Degassed water stored in the degassed water storage tank shall be pumped by MB Feed Pumps to mixed bed to meet the **boiler make-up water quality**. Necessary regeneration system shall be included in the MB system package for regeneration of MB resins. Bulk storage tanks & Unloading pumps for chemicals are included in the bidder's scope. Preliminary drawings for P&ID & Layout for the MB system are enclosed for further reference.

**Note :**

Regarding terminal points, please refer attached equipment layout.

**Part-1. Design, Engineering, Manufacturing, shop testing, supply to BHEL stores at site.**

**Part-2. Collection of materials / equipment from BHEL site stores, transportation to erection spot, erection of the complete Degasser system, MB system, MB Regeneration System, Bulk Storage System along with associated pipes & valves, with providing necessary supports, stage clearance, testing, commissioning, trial run & performance guarantee test and handing over of the entire system.**

**2.0 PROJECT INFORMATION**

**Owner** : Karnataka Power Corporation Ltd. Bellary.  
**Project Title** : KPCL- Yelahanka  
**Location** : Yelahanka, Bangalore.

|                                                                                   |                                               |                   |
|-----------------------------------------------------------------------------------|-----------------------------------------------|-------------------|
|  | <b>SPECIFICATION FOR<br/>MIXED BED SYSTEM</b> | SPEC. No:ROS-6154 |
|                                                                                   |                                               | REV: 00           |

### 3.0 TECHNICAL REQUIREMENT

#### 3.1 MB PLANT CAPACITY

MB unit shall be capable of producing Boiler Make-up water of required quality using design inlet water quality, specified in this specification, with the **net output capacity of 20 cu.m/hr** on continuous operation basis. The net output between regeneration (OBR) continuous operation basis shall be 960 cu.m in 3 days ( 16 hrs per day and total 48 hrs).

- a. No of streams of the MB system = 1 Working
- b. Net output capacity of MB system = 20 cu.m / hr
- c. Net output between regeneration of MB system = 960 cu.m

#### 3.2 INLET WATER QUALITY FOR DESIGN OF MB SYSTEM

The inlet water quality to be considered for design is from **2nd** stage (permeate staging) RO system and the analysis is indicated below.

##### SECOND STAGE RO PERMEATE WATER QUALITY:

| Sl.No | Parameters                                   | Unit   | Design    |
|-------|----------------------------------------------|--------|-----------|
| 1     | pH                                           |        | 4.5 - 5.5 |
| 2     | Conductivity                                 | µS./cm | 22        |
| 3     | Temperature - Design                         | deg C  | 28        |
|       | - Min & Max                                  | Deg C  | 22 & 35   |
| 4     | Total dissolved Solids                       | mg/l   | <12       |
| 5     | Carbon di Oxide as CO <sub>2</sub> - Design  | ppm    | 100 *     |
| 6     | Carbon di Oxide as CO <sub>2</sub> - Maximum | ppm    | 120 *     |
| 7     | SiO <sub>2</sub> as SiO <sub>2</sub>         | ppm    | 0.4       |
| 8     | Sodium as Na                                 | ppm    | 3.0       |
| 9     | Potassium as K                               | ppm    | 0.1       |
| 10    | Calcium as Ca                                | ppm    | 0.6       |
| Sl.No | Parameters                                   | Unit   | Design    |
| 11    | Magnesium as Mg                              | ppm    | 0.1       |
| 12    | Bicarbonate as HCO <sub>3</sub>              | ppm    | 4.5       |
| 13    | Chloride as Cl                               | ppm    | 3.3       |
| 14    | Sulphate as SO <sub>4</sub>                  | ppm    | 0.1       |

|                                                                                   |                                               |                   |
|-----------------------------------------------------------------------------------|-----------------------------------------------|-------------------|
|  | <b>SPECIFICATION FOR<br/>MIXED BED SYSTEM</b> | SPEC. No:ROS-6154 |
|                                                                                   |                                               | REV: 00           |

|    |                            |     |     |
|----|----------------------------|-----|-----|
| 15 | Nitrate as NO <sub>3</sub> | ppm | 0.2 |
| 16 | Fluoride as F              | ppm | 0.0 |

**NOTE:**

\* The CO<sub>2</sub> indicated is at the First stage RO permeate water.  
The degasser to strip the CO<sub>2</sub> is also included in scope of supply along with Mixed Bed System.

**3.3 OUTLET WATER QUALITY:**

The plant design should meet the outlet water quality as indicated below.

**3.3.1 DEGASSER OUTLET WATER QUALITY**

| Sl. No | Description                        | Unit | Values                     |
|--------|------------------------------------|------|----------------------------|
| 1      | Carbon di Oxide as CO <sub>2</sub> | ppm  | < 5.0 ppm at max flow rate |

**3.3.2 MIXED BED OUTLET WATER QUALIT**

| Sl.No | Description                           | Unit  | Values                                                          |
|-------|---------------------------------------|-------|-----------------------------------------------------------------|
| 1     | pH                                    |       | 6.8 to 7.2                                                      |
| 2     | Conductivity at 25 deg C              | μS/cm | 0.1 max                                                         |
| 3     | Silica as SiO <sub>2</sub> (reactive) | ppm   | 0.015 max                                                       |
| 4     | Organic matter                        | ppm   | Practically Free<br>(less than 0.2 mg of KmnO <sub>4</sub> /lt) |

**4.0: TECHNICAL SPECIFICATION - MECHANICAL**

**4.1 DESIGN CRITERIA**

The Mixed Bed (MB) unit shall be of **automatic operation** (but in case of regeneration, initiation shall be done manually and sequence of operation shall be automatic). RO Stage - 2 permeate water supplied shall be treated in Degassing System comprising of 1 x 100 % Degasser Tower, 2(1W+1S) x 100% Degasser Blowers and 1 x 100% Degassed Water Storage Tank. The degassed water shall be collected in a degassed water storage tank (MSRL-15 cu.m). The degasser tower shall be mounted on the degasser water storage tank.

As the feed water to the degasser will be directly connected from the membrane permeate outlet-having limitations of backpressures (1.0 bar maximum), bidders have to limit the degasser tower **height to less than 3 meters**.

|                                                                                   |                                               |                   |
|-----------------------------------------------------------------------------------|-----------------------------------------------|-------------------|
|  | <b>SPECIFICATION FOR<br/>MIXED BED SYSTEM</b> | SPEC. No:ROS-6154 |
|                                                                                   |                                               | REV: 00           |

The Degassed water shall be pumped through MB Feed pumps (1W+1S) to MB Unit. The MB unit shall be sized to meet the guaranteed output quality and quantity as called for in the specification.

A regeneration system shall be included in the design to regenerate the single mixed Bed unit. It shall consist of regeneration pumps (1W+1S) and 1 no. of AMT (1W) & 1 no. of CDT (1W) chemical tanks (measuring tanks), ejectors and MB regeneration blowers (1W+1S), along with required accessories separately for acid and alkali from bulk storage tank outlet. Please refer to the equipment layout for attached with this specification. The design shall take care of the collection of regeneration effluent, all drains of the plant at a common trench in the MB unit.

Necessary piping, pneumatic and manual operated valves, impulse tubing & accessories, instrument air line distribution for POV's, cabling between junction box to respective instruments / equipment's thro' cable trays, pneumatic operated diaphragm valves, limit switches, instruments, controls & Interlocks shall be provided in the system for auto operation and also as per the preliminary P&ID drawing enclosed along with this specification. The piping, impulse lines, cables, trays etc. shall be routed, installed suitable to have easy accessibility and aesthetic look.

The details of the equipment / system are elaborated in respective section of this specification.

#### 4.1.1 TERMINAL POINTS:

Scope and terminal point details are indicated in the enclosed drawing with this specification.

- a. Feed water will be supplied by the customer at the inlet of degasser tower flange.
- b. DM water from the MB system shall be terminated at 5 m distance outside the MB system building boundary. **The outlet pipe size shall be of DN 80, PN 10 rating and the required outlet pressure is 2 bar (g).**
- c. The DM water shall be made available at the outlet nozzle of DMWST with a flange & isolation valve. Further the suction piping, MB regeneration pumps, discharge piping & valves etc. up to MB system shall be in bidder's scope.
- d. Required compressed air will be made available at one common point in the MB system building.

|                                                                                   |                                               |                   |
|-----------------------------------------------------------------------------------|-----------------------------------------------|-------------------|
|  | <b>SPECIFICATION FOR<br/>MIXED BED SYSTEM</b> | SPEC. No:ROS-6154 |
|                                                                                   |                                               | REV: 00           |

## 4.2 EQUIPMENT SPECIFICATION - Mechanical

The technical requirements of the equipment are indicated below. In addition, the applicable P&ID and Layout enclosed with this specification shall be referred.

### 4.3 1 DEGASSER TOWER

- |    |                                 |                                                                                                           |
|----|---------------------------------|-----------------------------------------------------------------------------------------------------------|
| a. | Application                     | : To reduce CARBON DI OXIDE level. in the RO permeate water.                                              |
| b. | Quantity                        | : <b>1 x 100%</b>                                                                                         |
| c. | Operation                       | : Continuous.                                                                                             |
| d. | Installation                    | : Mounted on the top of Degassed water storage tank.                                                      |
| e. | Type                            | : Vertical tower type & forced draught.                                                                   |
| f. | Inlet water flow                | : 20 m <sup>3</sup> /hr (min)                                                                             |
| g. | Air to water ratio              | : 25 m <sup>3</sup> /m <sup>3</sup> (min)                                                                 |
| h. | Specific Velocity of water      | : 60 m <sup>3</sup> /hr/m <sup>2</sup> (max)                                                              |
| i. | DGT air vent velocity           | : 6 m/sec (max)                                                                                           |
| j. | Shell thickness & Height        | : Min.6.0 mm & approx. 3.0 m                                                                              |
| k. | Packing height                  | : 2.0 m (min)                                                                                             |
| l. | Material of Construction- Tower | : IS-2062 Gr-A.                                                                                           |
|    | -Rasching Ring                  | : Polypropylene.                                                                                          |
|    | - Grid                          | : FRP                                                                                                     |
| m. | Internal protection             | : Rubber lining 4.5 mm thick as per IS 4682 in min. two layers (2.2+ 2.3 mm) & shore hardness 65 ± 5 Gr.A |
| n. | Inlet design water quality      | : As per section 3.2 for Maximum inlet CO <sub>2</sub> level                                              |
| o. | Guaranteed Outlet water quality | : As per section 3.3                                                                                      |
| p. | Degasser inlet nozzle Elevation | : ~7 meter maximum from Ground Level ( <b>bidder to decide</b> ).                                         |
| q. | Design Code                     | : IS : 803                                                                                                |
| r. | Hydraulic Test Pressure         | : 1.5bar                                                                                                  |
| s. | Accessories                     | : All the ladders, platforms, pipe supports are in vendor's scope.                                        |

### 4.3.2 DEGASSER BLOWER WITH MOTOR

- |    |              |                                           |
|----|--------------|-------------------------------------------|
| a. | Application  | : To supply air to Degasser Tower         |
| b. | Quantity     | : <b>2 x 100 %</b> (1 Working +1 Standby) |
| c. | Operation    | : Continuous                              |
| d. | Type         | : Centrifugal,                            |
| e. | Installation | : Indoor in MB Building                   |
| f. | Flow         | : Bidder to Specify                       |
| g. | Head         | : Bidder to Specify                       |

|                                                                                   |                                               |                   |
|-----------------------------------------------------------------------------------|-----------------------------------------------|-------------------|
|  | <b>SPECIFICATION FOR<br/>MIXED BED SYSTEM</b> | SPEC. No:ROS-6154 |
|                                                                                   |                                               | REV: 00           |

- f. Accessories : Non return valve, Base frame, Suction filter, pressure gauge, anti-vibration Mountings, etc.
- h. MOC - Blower casing & impeller : MS  
- Shaft & Sleeve : EN 8 /ASTM A 321 & ASTM A276 TP316
- i. Motor : As per Electrical Spec.

#### 4.3.3 DEGASSED WATER STORAGE TANK

- a. Application : To store the degassed water from Degassed Tower
- b. Quantity : **1 x 100%**
- c. Capacity, m<sup>3</sup>/hr : 20 Cu.M (usable volume)
- d. Diameter : **2.4 m (min)**  
(Max. tank diameter based on limitation of degasser tower inlet nozzle elevation)
- f. Shell thickness shell & dishends : **6.0 mm / 6.0 mm**
- d. Type : Horizontal, Cylindrical & to hold the degasser tower on the top
- e. Material of Construction : IS-2062 Gr-A
- f. Internal protection : **Rubber lining 4.5 mm thick** as per IS 4682 & shore hardness 65 ± 5 Gr.A in two layers (2.2 + 2.3 mm)
- g. Nozzles : Inlet, Outlet, overflow, Drain, Sampling point, Vent, level switch, level indicator, Manhole, Fill nozzle etc. as required.
- h. Design Code : **IS 2825**
- i. Accessories : Necessary access ladder and hand rails

#### 4.3.4 MIXED BED VESSEL UNIT

- a. Application : To generate DM water for Boiler make-up
- b. Quantity : **1x 100 % (1 W)**
- c. Type : Vertical, Cylindrical
- d. Feed water quality : Degassed water outlet quality in section3.3.1
- e. MB Outlet quality : As per Section – 3.3.2
- f. Net guaranteed output, m<sup>3</sup>/hr : 20
- g. OBR m<sup>3</sup>: 960 between two successive regeneration
- h. Continuous Operating hours hrs : 48 (between two successive regeneration)
- i. Regeneration time hrs : 4 (max)
- j. Material : IS - 2062 Gr-A or Equivalent.



## SPECIFICATION FOR MIXED BED SYSTEM

SPEC. No:ROS-6154

REV: 00

- k. Internal protection : **Rubber lining 4.5 mm** thick  
(in two layers of thickness : 2.2+2.3 mm) as per  
IS: 4682 & shore hardness 65 ± 5 Gr. A
- l. Design Code : IS 2825
- m. Design Pressure : 6.0 bar (g) minimum.
- n. Test Pressure : 1.5 times of Design Pressure
- o. Vessel dia m : 1.2 approx. (Vendor to specify)
- p. Vessel shell thickness mm : 8 (min) – to be as per IS 2825
- q. Vessel dish thickness mm : 8 (min) – to be as per IS 2825
- r. Resin bed height : Minimum **0.5** m for Cation resin,  
Minimum **1.0** m for Anion resin.  
Or the minimum recommended in respective resin  
literature whichever is higher.  
However bidder to select increased resin bed  
height if required to meet the design ionic load.

(For the calculation of resin volume in ion exchange unit, ion exchange vessel sizing etc. 10% (ten percent) deration factor on corrected exchange capacity, as obtained from characteristic curves, shall be considered to provide margin towards ageing of resins. Resin calculation must be provided; Otherwise offer will be rejected).

- s. Free Board : 100% of bed height
- t. Surface flow rate m<sup>3</sup>/hr/m<sup>2</sup> : **> 10 and < 25**
- u. Acid available for regeneration : ~ 30% HCl, technical grade as per IS 265
- v. Alkali available for regeneration : ~ 48% NaOH rayon grade as per IS 252
- w. Resin life : Minimum **3** years for Anion resin &  
Minimum **5** years for Cation resin.
- x. Attrition loss of resins: Cation : 3 % per annum (max)  
Anion : 5% per annum (max)
- y. Resin type Cation : High capacity premium, strongly acidic,  
Sulphonated polystyrene base, cross linked  
polystyrene & gel structure Cation exchange  
resins.  
Anion : Strongly basic polystyrene base  
macroporous type-I anion exchange resins.  
The anion resin shall be able to withstand a  
temperature of 60 deg C. **Type –II resin will**

|                                                                                   |                                               |                   |
|-----------------------------------------------------------------------------------|-----------------------------------------------|-------------------|
|  | <b>SPECIFICATION FOR<br/>MIXED BED SYSTEM</b> | SPEC. No:ROS-6154 |
|                                                                                   |                                               | REV: 00           |

**not be accepted.**

- Resin make : Ion Exchange / Thermax / Rohm & Hauss / Dow
- z. Accessories : Necessary Resin traps at service inlet, service outlet, rinse outlet, drain down line (Nozzle size shall be min.100NB with an internal nozzle to mount the resin trap) resin removal nozzles (min. dia 100 NB), distributor nozzles, inlet / outlet / regeneration nozzles, drain, vent, necessary sight glass (**3 nos- MOC of Borosilicate toughened glass**) of clear width not less than 75 mm, for viewing resin level, pneumatic operated valves for automatic operation / regeneration, access ladder with safety cage, handrails at vessel top, two (2 nos) davit type manholes (dia 500 mm size minimum) davit type and an access below the bed plate ( ie. strainer on plate) etc.
- aa. Support Legs:
- Quantity : 4 Nos.
- Size : Vendor to decide  
with necessary gusset plates for reinforcement.
- Base Plate : ~ 350 x 350 x 20 (L x B x thick)(minimum)
- ab. Thinning allowance for dished ends : **2.0 mm (min.)**
- ac. Corrosion allowance for shell & dish end: **1.5 mm (min)**
- ad: All fasteners for vessel internals & sight glass and manholes : **SS 316**
- ae. Bottom collector assembly : Strainer on plate.  
The bottom plate thickness must be minimum of **20 mm** with necessary bottom supports or calculated thickness whichever is higher.

#### **4.3.5 MIXED BED BLOWER WITH MOTOR**

- a. Application : To supply air to MB during regeneration.
- b. Quantity : **2 x 100 % (1 W + 1S)**
- c. Operation : Intermittent
- d. Installation : Indoor near Mixed Bed Building
- e. Type : Positive displacement -Twin Lobe
- g. Flow : 150 **m<sup>3</sup>/hr** (min) or higher (**bidder to decide**).
- h. Head : 0.5 bar (g) (min)

|                                                                                   |                                               |                   |
|-----------------------------------------------------------------------------------|-----------------------------------------------|-------------------|
|  | <b>SPECIFICATION FOR<br/>MIXED BED SYSTEM</b> | SPEC. No:ROS-6154 |
|                                                                                   |                                               | REV: 00           |

- i. MOC - Blower Casing & Impeller: CI IS 210 FG 260 or Equivalent  
- Shaft & Sleeve : EN 8 /ASTM A 321 & ASTM A276 TP316
- j. Motor : As per Electrical Spec.
- k. Accessories : Silencers, Non return valve, Pulleys with V-belts & guard, Base frame, Pr. Relief valve, Suction filter, pressure gauge, anti-vibration mountings and flexible discharge connection etc.

#### 4.3.6 MIXED BED FEED PUMPS WITH MOTOR

- a. Application : To feed water to Mixed Bed units
- b. Quantity : **2 x 100 %** (1 W + 1S)
- c. Operation : Continuous
- d. Installation : Indoor
- e. Type : Centrifugal, Horizontal
- f. Suction : From Degassed Water storage tank
- g. Discharge Flow rate ,m3/hr : Bidder to select with 5% margin over duty point.
- h. Discharge head, mWC : Bidder to select with minimum 5% margin above the requirement. The head requirement to be calculated by considering the losses through resin bed, piping, valves, resin traps, orifice etc. in the MB system plus **2 bar (g)** pressure at MB final outlet terminal point.
  
- i. Speed, rpm : 3000 (max)
- j. MOC of all wetted parts :
  - Casing : SS 316
  - Impeller : SS 316
  - Shaft : SS 410 / SS 329
  - Shaft sleeve : SS 316
- k. Shaft Seal : Mechanical – API plan 11
- l. Coupling : Flexible coupling (Spacer type) with Guard
  
- m. Base frame for Pump & Motor mounting } : Carbon steel with epoxy coated.
- n. Bearing : Anti-friction
- o. All fasteners : SS316
- p. Motor : As per Electrical Specification

|                                                                                   |                                               |                   |
|-----------------------------------------------------------------------------------|-----------------------------------------------|-------------------|
|  | <b>SPECIFICATION FOR<br/>MIXED BED SYSTEM</b> | SPEC. No:ROS-6154 |
|                                                                                   |                                               | REV: 00           |

#### 4.3.7 MIXED BED REGENERATION PUMPS WITH MOTOR

- |    |                                      |   |                                                                                                                                                                                                                                                                                                                                  |
|----|--------------------------------------|---|----------------------------------------------------------------------------------------------------------------------------------------------------------------------------------------------------------------------------------------------------------------------------------------------------------------------------------|
| a. | Application                          | : | To supply DM water from DM water storage tank to Mixed Bed system                                                                                                                                                                                                                                                                |
| b. | Quantity                             | : | <b>2 x 100 % (1 W + 1S)</b>                                                                                                                                                                                                                                                                                                      |
| c. | Operation                            | : | Intermittent                                                                                                                                                                                                                                                                                                                     |
| d. | Installation                         | : | Indoor                                                                                                                                                                                                                                                                                                                           |
| e. | Type                                 | : | Centrifugal, Horizontal                                                                                                                                                                                                                                                                                                          |
| f. | Suction                              | : | From D.M. Water storage tank                                                                                                                                                                                                                                                                                                     |
| g. | Discharge Flow rate, m3/hr           | : | Bidder to select with 5% margin over duty point                                                                                                                                                                                                                                                                                  |
| h. | Discharge head, mWC                  | : | Bidder to select with minimum 5 % margin above the head required. The head requirement to be calculated by considering all losses in the MB system plus frictional loss of 70 m pipe segments whichever is higher at MB inlet terminal point. Bidder to specify the pipe size & pressure rating for all the pipelines & headers. |
| i. | Speed, rpm                           | : | 3000 (max)                                                                                                                                                                                                                                                                                                                       |
| j. | MOC of all wetted parts              | : |                                                                                                                                                                                                                                                                                                                                  |
|    | Casing                               | : | SS 316                                                                                                                                                                                                                                                                                                                           |
|    | Impeller                             | : | SS 410 / SS 329                                                                                                                                                                                                                                                                                                                  |
|    | Shaft                                | : | SS 316                                                                                                                                                                                                                                                                                                                           |
|    | Shaft sleeve                         | : | SS 316                                                                                                                                                                                                                                                                                                                           |
| k. | Shaft Seal                           | : | Mechanical – API plan 11                                                                                                                                                                                                                                                                                                         |
| l. | Coupling                             | : | Flexible coupling (spacer type) with Guard                                                                                                                                                                                                                                                                                       |
| m. | Base frame for Pump & Motor mounting | } | Carbon steel with epoxy coated.                                                                                                                                                                                                                                                                                                  |
| n. | Bearing                              | : | Anti-friction                                                                                                                                                                                                                                                                                                                    |
| o. | All fasteners                        | : | SS 316                                                                                                                                                                                                                                                                                                                           |
| p. | Motor                                | : | As per Electrical Spec.                                                                                                                                                                                                                                                                                                          |

#### 4.3.8 MB REGENERATION SYSTEM: 1 Set consisting of Two Tanks & accessories

- |    |                       |   |                                |                                  |
|----|-----------------------|---|--------------------------------|----------------------------------|
| a. | Tanks                 | : | Acid measuring Tank (AMT) 1No. | Alkali measuring Tank (CDT)1 No. |
|    | MOC                   | : | MSRL                           | <b>FRP with PP linings</b>       |
|    | Tank thickness for MS | : | <b>6.0</b> mm (min)            | -----                            |
|    | for FRP               | : | ----                           | <b>10</b> mm (min)               |
|    | Fume absorber         | : | 1 No.                          | Not applicable                   |
|    | Fume absorber- MOC    | : | FRP /MSRL                      |                                  |

|                                                                                   |                                               |                   |
|-----------------------------------------------------------------------------------|-----------------------------------------------|-------------------|
|  | <b>SPECIFICATION FOR<br/>MIXED BED SYSTEM</b> | SPEC. No:ROS-6154 |
|                                                                                   |                                               | REV: 00           |

(HDPE is not acceptable)

Internal protection : FRP tanks (with PP lining minimum 3 mm thick). MSRL tanks with Rubber lining 4.5 mm thick (2.2+2.3 mm) in two layers as per IS 4682, shore hardness 65 ± 5 Gr. A for MSRL tanks.

- b. Accessories : Ejectors, piping, valves, mixers & safety showers with eye-wash, Fume absorber for AMT etc.,

#### 4.3.9 BULK ACID STORAGE (HCl) STORAGE SYSEM

- a. Tanks : Bulk Acid storage
- b. Medium used : 30 to 33 % Hydrochloric Acid
- c. Location : Outdoor
- d. Quantity : 1 no.
- e. Capacity (usable volume) : 15 m<sup>3</sup>
- f. MOC : MSRL
- g. Type : Horizontal, Cylindrical with dished ends
- h. Pressure : Atmospheric
- i. Design Code : BS:2594
- j. Tank dia : 2.0 m (min) (inside)
- k. Tank shell thickness : **10.0** mm (min)
- l. Thinning allowance for dished ends : 2.0 mm
- m. Corrosion allowance for shell Dished ends : 1.5 mm
- n. Internal Protection : Rubber lining min. 4.5 mm thick (two layers of thickness: 2.2 + 2.3) as per IS 4682, shore hardness 65± 5 Gr. A
- o. External protection : As per BHEL spec. section 4.7
- p. Piping, Valves & Fittings : CPVC
- q. Tank Nozzle flange thickness : **15.0** mm (min)
- r. Piping & fittings : CPVC
- s. Valves : Metallic diaphragm valves with Ebonite rubber lined
- t. Accessories : Each tank consists of necessary manholes, inlet / outlet / drain & vent nozzles, piping, valves, level indicator, level switch, access ladder with safety cage, top platform, hand rails for manhole access, safety showers, eyewash etc. Suitable handling arrangement / lifting lugs are to be provided in the tank for easy movement.
- u. Hydro test : The tank shall be hydro tested up to 2 .0 bar

|                                                                                   |                                               |                   |
|-----------------------------------------------------------------------------------|-----------------------------------------------|-------------------|
|  | <b>SPECIFICATION FOR<br/>MIXED BED SYSTEM</b> | SPEC. No:ROS-6154 |
|                                                                                   |                                               | REV: 00           |

The height of the pedestals shall be 5.0 m from FGL (This is for piping & valves estimation)

#### 4.3.10 HYDROCHLORIC ACID (HCl) UNLOADING PUMPS

- |    |                                         |                                                                                                                                                                                                                                                                                                                                                            |
|----|-----------------------------------------|------------------------------------------------------------------------------------------------------------------------------------------------------------------------------------------------------------------------------------------------------------------------------------------------------------------------------------------------------------|
| a. | Application                             | : To unload liquid HCl of 30 to 33% solution from tanker lorry at road.                                                                                                                                                                                                                                                                                    |
| b. | Quantity                                | : <b>2 No (1 W + 1S)</b>                                                                                                                                                                                                                                                                                                                                   |
| c. | Discharge Flow rate, m <sup>3</sup> /hr | : 10                                                                                                                                                                                                                                                                                                                                                       |
| d. | Discharge head, M of <b>WC</b>          | : 25                                                                                                                                                                                                                                                                                                                                                       |
| e. | Operation                               | : intermittent                                                                                                                                                                                                                                                                                                                                             |
| f. | Installation                            | : Outdoor                                                                                                                                                                                                                                                                                                                                                  |
| g. | Type                                    | : Centrifugal, Horizontal                                                                                                                                                                                                                                                                                                                                  |
| h. | Suction                                 | : From tanker lorry                                                                                                                                                                                                                                                                                                                                        |
| j. | Shaft Seal                              | : Mechanical seal – API plan 11                                                                                                                                                                                                                                                                                                                            |
| k. | MOC of all wetted parts                 | : PP                                                                                                                                                                                                                                                                                                                                                       |
| l. | Bearing                                 | : Anti-friction                                                                                                                                                                                                                                                                                                                                            |
| m. | Coupling                                | : Flexible coupling (Spacer type) with Guard                                                                                                                                                                                                                                                                                                               |
| n. | Base frame for Pump & Motor mounting    | : Carbon steel with epoxy coated.                                                                                                                                                                                                                                                                                                                          |
| o. | Accessories                             | : Suction pipe / rigid hose 10 m minimum, Suction strainer (Y-type), drain and vent valves, delivery piping to storage tank and flushing arrangement piping for the flushing of the pump after unloading the chemical etc. The operation of the pump shall be controlled by the level switch in the tank( pump shall be stopped before the tank overflows) |
| p. | Strainers                               | : CPVC                                                                                                                                                                                                                                                                                                                                                     |
| q. | Valves                                  | : Metallic diaphragm valves with ebonite rubber lined                                                                                                                                                                                                                                                                                                      |
| r. | All fasteners                           | : SS316                                                                                                                                                                                                                                                                                                                                                    |
| s. | Motor                                   | : As per specification ROS: 4140                                                                                                                                                                                                                                                                                                                           |

#### 4.3.11 BULK ALKALI (NaOH) STORAGE SYSTEM:

- |    |                                    |                                            |
|----|------------------------------------|--------------------------------------------|
| a. | Tanks                              | : Bulk Alkali storage                      |
| b. | Medium used                        | : 48 % Sodium Hydroxide chemical           |
| c. | Location                           | : outdoor                                  |
| d. | Quantity                           | : 1 no.                                    |
| e. | Capacity (usable volume)           | : 15 m <sup>3</sup>                        |
| f. | MOC                                | : MSRL                                     |
| g. | Type                               | : Horizontal, Cylindrical with dished ends |
| h. | Pressure                           | : Atmospheric                              |
| i. | Design Code                        | : BS-2594                                  |
| j. | Tank dia                           | : 2.0 m (min. inside)                      |
| k. | Tank shell thickness               | : <b>10.0</b> mm (min)                     |
| l. | Thinning allowance for dished ends | : 2.0 mm                                   |

|                                                                                   |                                               |                   |
|-----------------------------------------------------------------------------------|-----------------------------------------------|-------------------|
|  | <b>SPECIFICATION FOR<br/>MIXED BED SYSTEM</b> | SPEC. No:ROS-6154 |
|                                                                                   |                                               | REV: 00           |

- m. Corrosion allowance for shell : 1.5 mm  
And dished ends
- n. Internal Protection : Rubber lining min. 4.5 mm thick (two layers of thickness: 2.2+ 2.3) as per IS 4682, shore hardness 65 ±5 Gr. A
- o. External protection : As per BHEL spec. section 4.7
- p. Piping, Fittings : CPVC
- q. Tank Nozzle flange thickness : **15.0** mm (min)
- r. Piping & fittings : CPVC
- s. Valves & strainers : CPVC
- t. Accessories : Each tank consists of necessary manholes, inlet / outlet / drain & vent nozzles, piping, valves, level indicator, level switch, access ladder with safety cage, platform, hand rails for manhole access, safety showers, etc. Suitable handling arrangement / lifting lugs are to be provided in the tank for easy movement.
- u. Hydro test : The tank shall be hydro tested up to 2 .0 bar
- v. The height of the pedestals shall be 5.0 m from FGL (This is for piping & valves estimation)

#### 4.3.12 SODIUM HYDROXIDE UNLOADING PUMPS

- a. Application : To unload liquid Sodium Hydroxide 48% from road tanker
- b. Quantity : **2 Nos (1 W + 1S)**
- c. Discharge Flow rate, m<sup>3</sup>/hr : 10
- d. Discharge head, **M of WC** : 25
- e. Operation : intermittent
- f. Installation : Outdoor
- g. Type : Centrifugal, Horizontal
- h. Suction : From tanker lorry
- j. Shaft Seal : Mechanical seal – API plan 11
- k. MOC of all wetted parts : SS 316 /SS 304
- l. Bearing : Anti-friction
- m. Coupling : Flexible coupling (Spacer type) with Guard
- n. Base frame for Pump & Motor mounting } : Carbon steel with epoxy coated.
- o. Accessories : Suction pipe / **rigid hose 10 m minimum**, Suction strainer (Y-type), drain and vent valves, delivery piping to storage tank and flushing arrangement piping for the flushing of the pump after unloading the chemical etc.  
The operation of the pump shall be controlled by the level switch in the tank ( pump shall be stopped before the tank overflows)

|                                                                                   |                                               |                   |
|-----------------------------------------------------------------------------------|-----------------------------------------------|-------------------|
|  | <b>SPECIFICATION FOR<br/>MIXED BED SYSTEM</b> | SPEC. No:ROS-6154 |
|                                                                                   |                                               | REV: 00           |

- p. Valves& strainers : CPVC  
q. All fasteners : SS316  
r. Motor : As per specification ROS:4140.

#### 4.3.13 N-PIT effluent transfer pumps:

- a. Application : To transfer the N-PIT effluents  
b. Quantity : **2 x 100 %** (1 W + 1S)  
c. Operation : Intermittent  
d. Installation : outdoor  
e. Type : Centrifugal, Horizontal  
f. Suction : From Neutralization pit  
g. Discharge Flow rate, m3/hr : 25 m3/hr with 5% flow margin over duty point  
h. Discharge head, mWC : 25 mwc with minimum 5% head margin above duty point  
i. Speed, rpm : 3000 (max)  
j. MOC of all wetted parts :  
Casing : SS 316  
Impeller : SS 316  
Shaft : SS 316  
Shaft sleeve : SS 316  
k. Shaft Seal : Mechanical – API plan 11  
l. Coupling : Flexible coupling (spacer type) with Guard  
m. Base frame for Pump & Motor mounting } : Carbon steel with epoxy coated.  
n. Bearing : Anti-friction  
o. All fasteners : SS 316  
p. Motor : As per Electrical Spec. ROS:4140

#### 4.3.14 PIPING CHAMBER

1. Equipment : Priming chamber and accessories with suitable saddles
  2. Application : Pumping of N-pit water from Desalination plant.
  3. pH : 5 - 11
  4. Surrounding : Dusty and humid atmosphere
  5. Installation : out door
  6. Ambient Temperature : 50 °C Maximum & 15 °C Minimum
  7. Operation : Continuous
- (a). Technical details :
- 1) Quantity : 2 Nos.
  - 2) Type : Cylindrical
  - 3) Capacity : 0.75 m3 (min) Vendor to decide
  - 4) Dimensions : As per enclosed typical sketch
  - 5) Shell MOC : IS: 2062 Gr. B



## SPECIFICATION FOR MIXED BED SYSTEM

SPEC. No:ROS-6154

REV: 00

- |     |                      |                                                     |
|-----|----------------------|-----------------------------------------------------|
| 6)  | TOP & Bottom plate   | : IS: 2032 Gr. B                                    |
| 7)  | Nozzle               | : ASTM A 53/ ASTM A106 Gr. B, Sch.40                |
| 8)  | Nozzle size & rating | : As per Typical sketch, PN 10, Class # 150 off CRS |
| 9)  | Bolts & Nuts         | : GI                                                |
| 10) | Gaskets              | : 6 mm thick Neoprene Rubber                        |
| 11) | Internal protection  | : Epoxy paint ( 225 micron thick)                   |
| 12) | External protection  | : Epoxy paint 175 micron thick                      |
| 13) | Support legs         | : MS                                                |

### (b) DESIGN DATA

- |    |                     |                                     |
|----|---------------------|-------------------------------------|
| 1. | Design code         | : API 650 / IS: 803                 |
| 2) | Design pressure     | : Atmospheric.                      |
| 2) | Design temperature  | : 65 Deg. C                         |
| 3) | Test pressure       | : 2 Kg/cm <sup>2</sup> .            |
| 4) | Corrosion allowance | : 3 mm                              |
| 5) | Joint efficiency    | : shell 0.7, Bottom & top plate 0.7 |

### (c). Scope of supply

- (1). Priming chamber (tank) with suitable saddle supports : 2 Nos
- (2). Foot valve - 2 nos. with flanged end connection (Vacuum lift)  
MOC : PP or equal  
Pressure rating : 2 bar  
Size : Vendor to decide  
Flange drilling : ANSI B 16.5, CL-150.
- (3). (a) Ball valve for service water inlet for initial priming
  1. Type : Flanged end, hand lever operated
  2. Size : 50 - 2 Nos.
  3. Moc : Body : CI, Ball : SS 316, Seat : EPDM rubber, Fasteners : SS 316
  4. Flange drilling : ANSI B 16.5, CL-150.

### (b). Ball valve for water air vent & drain

1. Type : Flanged end, hand lever operated
2. Size : DN 25 - 4 Nos.
3. Moc : Body : CI, Ball : SS 316, Seat : EPDM rubber, Fasteners : SS 304
4. Flange drilling : ANSI B 16.5, CL-150.

- (4). Rubber gasket (Neoprene / EPDM ) - 1 lot.  
Applicable fasteners - 1 lot ( SS 304 )

### **4.3.15 Diffuser piping arrangement for N-pit**

- |    |                    |                    |
|----|--------------------|--------------------|
| 1. | Purpose            | : N-pit air mixing |
| 2. | Qty.               | : Vendor to decide |
| 3. | Size & arrangement | : Vendor to decide |
| 3. | MOC                | : Vendor to decide |

|                                                                                   |                                               |                   |
|-----------------------------------------------------------------------------------|-----------------------------------------------|-------------------|
|  | <b>SPECIFICATION FOR<br/>MIXED BED SYSTEM</b> | SPEC. No:ROS-6154 |
|                                                                                   |                                               | REV: 00           |

4. N pit-capacity : 50 Cu. m each (twin compartment)

#### 4.3.16 PIPING AND VALVES

- a. Piping : Refer section 4.5
- b. Valves : Refer section 4.6

#### 4.4 GENERAL DESIGN REQUIREMENTS

The common requirements for the system are stated in the general design requirements. However the requirements indicated in the equipment specification section 4.3 shall be strictly complied with.

##### 4.4.1 COMMON REQUIREMENTS FOR ALL SYSTEM:

1. Only latest revision of standard shall be used.
2. The design pressure of pressure vessel shall be minimum 5% higher than the pressure experienced in the system like pump shut-off operation, higher operating pressure at allowable electrical supply variations etc.
3. All the rotating equipments noise level shall be < 85db measured at 1 meter distance from the equipment.
4. The tanks coming in contact with corrosive fluids should be rubber lined as indicated in the specification for mechanical equipments.
5. All carbon steel pipelines unless otherwise specified elsewhere-carrying corrosive fluids should be rubber lines inside to a thickness of at least 3.0 mm (2 layers).
6. The minimum thickness of carbon steel plates for shell and dish end of vessels shall be 6.0 mm. No thinning is allowed.
7. The design temperature of all vessels shall be taken as minimum **65 deg C**.
8. Sampling connections and air vent at the top most point of piping and vessels shall be provided at all stages of the Unit.
9. The size of the overflow pipes of all storage tanks shall be one size higher than inlet pipe sizes of these tanks.
10. Motor rating shall be minimum of **116%** of the duty point requirement and also to meet the maximum power requirement over the operating range at 50 Hz frequency.
11. Necessary access to be provided for all manholes & sight glasses.

|                                                                                   |                                               |                   |
|-----------------------------------------------------------------------------------|-----------------------------------------------|-------------------|
|  | <b>SPECIFICATION FOR<br/>MIXED BED SYSTEM</b> | SPEC. No:ROS-6154 |
|                                                                                   |                                               | REV: 00           |

12. All valves and piping shall be supported suitably with cushion/ rubber sheet of suitable thickness & bolted with “U” clamp. The supporting truss must have minimum width of 1.5 times of the pipe diameter and base plate of thick of 12 mm (minimum).
13. Providing of structural supports by raw material supply & fabrication suitably at site for DM water piping from DM water storage tank to MB, regeneration water piping from regeneration pump to MB,AMT/CDT & bulk chemical transfer piping from bulk storage tanks to AMT/CDT are under the scope of bidder.
14. Suitable platforms, walkways, stairways, cage type ladders etc. for access to all equipment shall be provided by the bidder.
15. All platforms and stairways shall have minimum clear width of 800 mm. All platforms, stairways, landings etc. shall have railings and guards. Platform for interlinking all vessels with cage-ladders shall be provided for more than one vessel. The ladders & platforms shall have handrails for safe climbing and access. All the manholes shall have ladder for approach and platforms for landing.
16. All metallic valves shall be rubber lined
17. All the valves are to be located to facilitate easy accessibility and operation from the ground level.
18. All the pipeline flange fasteners shall be of GI MOC with 2 sets of washers.
19. Vessel Internal supporting cleats shall be of SS316.
20. The direction of Flow shall be indicated by an arrow at regular intervals on all pipelines with luminous paint. The size of arrow shall be suitably selected so that it shall be visible from any direction
21. All the equipments, valves & other items / components shall be tagged with corresponding KKS number as per PID. KKS number will be informed during execution stage.
22. Name of all vessels, tanks and tank capacity shall be painted on the respective vessel/tank prominently (after erection) with letter size of at least 150 mm tall by means of stencil.
23. Free board shall be provided over resin bed, below the backwash outlet nozzle and in straight portion of vessel to allow for expansion during backwashing.
24. All the ion exchanger vessels shall be provided with additional nozzles with flange for hydraulic transfer of resin as and when necessary arises. The nozzle shall be provided with manual valves of 100 mm NB. Dummy flanges, gaskets and fasteners are bidder's scope.
25. The guaranteed conductivity value must be attained after completion of regeneration and / or during fast rinse of 15 minutes duration maximum.

|                                                                                   |                                               |                   |
|-----------------------------------------------------------------------------------|-----------------------------------------------|-------------------|
|  | <b>SPECIFICATION FOR<br/>MIXED BED SYSTEM</b> | SPEC. No:ROS-6154 |
|                                                                                   |                                               | REV: 00           |

#### 4.4.2 Vessels & Tanks

All vessels & tanks except those specified otherwise shall be made of steel with suitable rubber lining. All steel tanks furnished by the bidder shall be designed suitable for operating condition. All pressure vessels shall be designed and tested to withstand **1.5** times of the design pressure. All the tanks shall be provided with suitable supporting legs, inlet and outlet connections, hand hole, manholes, nozzle connections for level gauges, vents, drains, overflow, access with safety cage ladders, landing & maintenance platforms, approach ladder for sight glass, handrails etc. as may be required. They shall be lined with suitable material capable of satisfactorily withstanding respective fluids to be handled by them.

All the tanks including chemical solution shall be provided with drain valves and piping, overflow piping and the same shall be led to a nearest drain sump. All the chemical tanks like AMT & CDT shall be provided with removable top covers in single piece. Top lid shall be provided with adequate number of nozzles for air vent, level switch/level transmitter mountings.

Design of pressure vessels shall conform to IS 2825 and atmospheric tanks shall conform to IS-803. All the nozzles shall be provided with necessary valves for open / close for regeneration operation.

All the manhole doors shall be provided with davit arrangement.

All the vessels nozzles shall be fitted with leak proof dummy flanges along with gaskets before dispatch.

#### 4.4.3 FRP Tanks / Pipe design considerations:

Tanks shall be vertical, cylindrical, (tapered bottom wherever needed) with level indication. The top cover shall be flanged type with suitable reinforcing and bracing. Each tank shall have four support pads with bolt hole & PCD not more than 150 mm beyond the tank diameter.

Nozzles on top, sideways and bottom heads shall have a flanged faces perpendicular to the vertical centerline of the tank and nozzles on sidewalls shall have flanges faces perpendicular to radial centerlines. Tolerance on angle of flange face with respect to tank centerline is ½ degree. All the nozzles with flange shall be molded integrally with tanks.

The tank shall be continuous filament wound type and there shall be no long seam joint in the cylindrical shell. Filament wound reinforced tanks shall be considered. The minimum total laminate thickness of the filament wound tank shall not be less than 10 mm all around and minimum 10 mm for tank flange and flanged top cover, tank

|                                                                                   |                                               |                   |
|-----------------------------------------------------------------------------------|-----------------------------------------------|-------------------|
|  | <b>SPECIFICATION FOR<br/>MIXED BED SYSTEM</b> | SPEC. No:ROS-6154 |
|                                                                                   |                                               | REV: 00           |

bottom corners and all nozzle flanges without exception. PP lining shall be provided for a min. thickness of 3 mm for alkali.

Each tank shall have inlet, outlet, drain, overflow, service water inlet, level indication nozzles etc. Overflow lines shall be minimum one size higher than tank inlet line. Each tank shall be equipped with a flanged level indicator / gauge. The gauge shall include two CPVC isolation ball valve, 20 mm dia glass tube and indicator board calibrated in cm.

Resin used for the tanks shall be of suitable grade, corrosion-resistant thermosetting, fully tested and accepted for the severe conditions. All internal surfaces, exposed to chemical, shall be resin rich and the thickness of this inner layer shall be minimum of 2 mm by vinyl ester resin. Isophthalic resin shall be used for rest of the thickness lamination. The glass content of inner layer shall be 25 to 30 % by weight. The glass content of filament wound structural layer shall be 55 to 70 % by weight. UPVC/PP lining shall be provided for a min. thickness of 2mm.

Suitable opening shall also be provided in these tanks to house agitator.

The guide lines stated above is also holds good for FRP pipe line with applicable pressure rating. (The glass content of inner layer shall be 25 to 30 % by weight. The glass content of filament wound structural layer shall be 55 to 70 % by weight).

#### **4.4.4 CENTRIFUGAL PUMPS:**

1. The critical speed of the pumps shall be well away from the operating speed and in no case less than 130% of the rated capacity.
2. The pumps shall have stable head Vs capacity characteristic continuous rising towards shut-off with an approximate shut-off head of 15% more than the design head for radial flow type pumps.
3. The characteristic curves of set of pumps shall match other for load sharing incase of parallel operation.
4. Pumps shall be provided with non-return valve & shut off valve on discharge side and shut-off valve on suction side.
5. The vibration level must be within the satisfactory zone as per ISO 10816-3:1998(E) for machine group 3 standard for rigid supported base with zone boundary B/C.
6. Tolerance on pump guaranteed efficiency and rated head for the rated flow shall be plus 3% to minus 2%.
7. Pressure gauges shall be provided on discharge side of all pumps individually.

|                                                                                   |                                               |                   |
|-----------------------------------------------------------------------------------|-----------------------------------------------|-------------------|
|  | <b>SPECIFICATION FOR<br/>MIXED BED SYSTEM</b> | SPEC. No:ROS-6154 |
|                                                                                   |                                               | REV: 00           |

8. Each pump suction and discharge shall be installed with an expansion bellow.
9. The pumps shall be designed for continuous operation at its best efficiency to satisfy the performance requirements.
10. The pumps shall be controlled from remote panel and locally.

#### **4.4.5 DEMINERALISING SYSTEM:**

The demineralising system shall comprise of equipments as listed in equipment specification. However, the design criteria shall be as mentioned below:

1. MB unit shall be rated for a normal flow rate to meet net output between regeneration. The flow rate shall be sized suitably to meet the guarantee requirement.
2. The air blowers shall be designed to supply the required quantity of oil free compressed air at required pressure for mixing the Anion and Cation resins after regeneration. The supply shall also include all necessary piping, valves, fittings, pressure gauges, suction silencer-cum-filter, belt guard, relief valve etc.
3. Necessary Resin traps, distributor, nozzles, manholes, inlet / outlet / regeneration nozzles, drain, vent, necessary sight glasses for viewing resin level, mounting legs, valves for automatic operation / regeneration of the system in the mixed bed units shall be supplied with all necessary piping, valves.
4. Resin selection criteria, calculation for arriving at resin quantities and the resin characteristic curves shall be submitted along with the offer.
5. Bidder to consider regeneration process shall be based on **self-neutralization and** also to furnish chemical calculations for regeneration of resins.

#### **4.4.6 RESIN REGENERATION SYSTEM:**

##### **4.4.6.1 CATION & ANION REGENERATION:**

1. The Cation exchange resins shall be regenerated with Hydrochloric acid of ~30% concentration as per IS 265 and the Anion exchange resins will be regenerated with Sodium Hydroxide solution of ~48% concentration as per IS 252 technical grade / rayon grade. These chemicals will be drawn from Bulk storage tanks (Bulk storage tanks are included in bidders scope). The required chemicals are excluded from bidders scope. The required pump, valves, pipelines etc. required for the transfer of chemicals will be in bidders scope and the will be provided during ordering.
2. The bidder shall include the required regeneration equipments in their scope.

|                                                                                   |                                               |                   |
|-----------------------------------------------------------------------------------|-----------------------------------------------|-------------------|
|  | <b>SPECIFICATION FOR<br/>MIXED BED SYSTEM</b> | SPEC. No:ROS-6154 |
|                                                                                   |                                               | REV: 00           |

3. Acid measuring / dilution tank for the regeneration of cation resin shall be of sufficient capacity to store the quantity of acid required for atleast one regeneration with **25%** margin. The tank shall be of MSRL with removable top covers with level indicators. Fume absorber shall be provided for this tank. Nozzle shall be provided on the top lid for providing level transmitter.
4. Alkali measuring / dilution tank for the regeneration of anion exchanger shall be of sufficient capacity to store the quantity of alkali required for atleast one regeneration with **25%** margin. The tank shall be of FRP with UPVC / PP lining with removable top covers with level indicators to indicate the level. Suitable agitator shall be provided to dilute the NaOH solution from 48% to 30 %. Nozzle shall be provided on the top lid for providing level transmitter.
5. Separate hydraulic injector / ejector for anion and cation resins for diluting the alkali / acid to the required level and dosing it to respective resin shall be supplied.
6. Suitable density indicators and flow orifice board / plate shall be provided to determine the exact strength of the acid / alkali injected and flow rate to the exchanger. The flow indicator shall be of unbreakable type to withstand hydraulic hammer etc. and the make
7. The dilution ratio of the ejector shall be properly selected such that the bed can be effectively regenerated employing power water at the available pressure. The ejectors and nozzles shall be suitably designed for acid service and high velocity of liquid.
8. Safety showers with eye-wash meeting B.I.S specification shall be provided in the acid, alkali handling area (AMT & CDT area).

#### **4.4.6.2 DRAIN NEUTRALISING SYSTEM:**

1. Provision shall be made by the bidder to neutralize wastewater arising out of the regenerating chemicals. The arrangement shall be as follows:
  - a. Bidder should indicate the neutralizing chemical requirement to keep pH of the waste effluent generated, around **6.5 to 8.5**.
  - b. Priming chamber,

### **4.5 PIPING**

#### **4.5.1 LINE SIZING**

- a. Sizes of pipelines shall be selected such that the velocity of fluid in pipes does not exceed the following limits under conditions of maximum possible volumetric flow:

|                               |             |
|-------------------------------|-------------|
| Pump Suction                  | : < 1 m/sec |
| Pump Delivery                 | : < 2 m/sec |
| Service water / Potable water | : 1.5 m/sec |
| Compressed air                | : 15 m/s    |

|                                                                                   |                                               |                   |
|-----------------------------------------------------------------------------------|-----------------------------------------------|-------------------|
|  | <b>SPECIFICATION FOR<br/>MIXED BED SYSTEM</b> | SPEC. No:ROS-6154 |
|                                                                                   |                                               | REV: 00           |

- b. Lower values of velocities than those stated above shall be used to determine line size if dictated by considerations of pressure drop, NPSH, surges, water hammer, etc.
- c. The design flows considered in line sizing shall not be less than the rated capacities of equipment to which the piping is connected such as pumps, blowers, compressors, valves, flow limiting orifices, etc., or, the system mass balance diagrams.
- d. All high points in piping system shall be provided with vents along with valves. All low points shall be provided with drain along with drain valves.
- e. Necessary moisture traps shall be provided in the compressor air line at strategic location.
- f. Necessary supports for the considered pipelines are in the scope of bidder. The supporting arrangement shall be rigid and properly designed for the systems where hydraulic shocks and pressure surges may arise in the system during operation.
- g. Sufficient upstream and downstream lengths shall be provided for flow measuring device, control valves and other specialties.
- h. Bidder shall provide suitable sampling points with SS 316 valves to take water samples for testing purpose. The water samples shall be through 20 mm NB dia pipes of SS 316.
- i. Test certificate / Compliance certificate to be furnished by the bidder for all the MSRL, SS, GRP/FRP piping and piping components etc.

|                                                                                   |                                               |                   |
|-----------------------------------------------------------------------------------|-----------------------------------------------|-------------------|
|  | <b>SPECIFICATION FOR<br/>MIXED BED SYSTEM</b> | SPEC. No:ROS-6154 |
|                                                                                   |                                               | REV: 00           |

#### 4.5.2 MATERIAL OF CONSTRUCTION:

| SL. NO. | SERVICE                                     | SIZE              | PIPES                               | FITTINGS                       | FLANGES              | GASKETS                   | LINE JOINT             |
|---------|---------------------------------------------|-------------------|-------------------------------------|--------------------------------|----------------------|---------------------------|------------------------|
| 1.1     | MB FEED WATER                               | NB 100 MM & BELOW | UPVC/CPVC, schedule 80 of ASTM      | UPVC/CPVC, schedule 80 of ASTM |                      | NEOPRENE RUBBER / EPDM    | FLANGED                |
|         |                                             | NB 150 MM & ABOVE | ASTM A312 TP 316L / CF8M            | ASTM A403 Gr.WP 316/A 182-F316 | ASTM A105            | NEOPRENE RUBBER / EPDM    | FLANGED                |
| 1.2     | MB Frontal piping                           |                   | CPVC, schedule 80 of ASTM           | CPVC, schedule 80 of ASTM      |                      | NEOPRENE RUBBER / EPDM    | FLANGED                |
| 1.3     | DEMINERALISED WATER (MB OUTLET)             | NB 100 MM & BELOW | ASTM A312 TP 316L / CF8M            | ASTM A403 Gr.WP 316/A 182-F316 | ASTM A105            | NEOPRENE RUBBER / EPDM    | FLANGED                |
|         |                                             | NB 150 MM & ABOVE | ASTM A312 TP 316L / CF8M            | ASTM A403 Gr.WP 316/A 182-F316 | ASTM A105            | NEOPRENE RUBBER / EPDM    | FLANGED                |
| 1.4     | INSTRUMENT AIR SYSEM & POTABLE WATER SYSTEM | NB 50MM & BELOW   | ASTM A53 GALVANISED / IS-1239-Heavy | ASTM A234 Gr. WPB GALVANISED   | ASTM A105 GALVANISED | NEOPRENE RUBBER / EPDM    | SCREWED                |
| 1.5     | CHEMICALS Like HCl, NaOH, NaOCL etc.        | ALL SIZES         | CPVC, schedule 80 of ASTM           | CPVC, schedule 80 of ASTM      | CPGF / PP            | EPDM /Viton rubber gasket | Flanged / insitu joint |

#### Notes

1. The material of DM water system Piping from MB outlet to DM water storage tank shall be ASTM A 312 TP 316L. Thickness shall be to suit system requirement. However minimum schedule 10 thick pipes shall be used. Fittings shall be of SS 316L and corresponding pipe thickness (Refer TP details of Tender equipment layout).
2. Pipes shall be tested for its material composition and certificate shall be enclosed for the same. Each length of pipe shall be hydro-tested at shop as per the Codes/Standards.
3. Blind flanges on SS Pipe lines shall be to ASTM A 240-TP 316. Stub ends shall be used at flanged connections.
4. Cast steel valves shall be provided for compressed air system.

|                                                                                   |                                               |                   |
|-----------------------------------------------------------------------------------|-----------------------------------------------|-------------------|
|  | <b>SPECIFICATION FOR<br/>MIXED BED SYSTEM</b> | SPEC. No:ROS-6154 |
|                                                                                   |                                               | REV: 00           |

5. All branch connections shall be wrought or forged steel based on the size and availability based on ASTM Standards.
6. All piping from RO stage-2 permeate storage tank to mixed bed vessels outlet including frontal piping shall be trial assembled and tested before despatch.
7. All piping & valves supports shall be of dismantling type for easy maintenance using suitable bolted connections.
9. All non metallic piping shall be UPVC / CPVC, industrial grade, Schedule 80, GF or Astral or FIP make including diaphragm valves, where ever called for. For more details refer cl. 4.5.2.

#### **4.5.3 LAYOUT & DETAILING**

1. A good engineering practice must be followed in manufacturing the piping weldments like edge preparation, slope, drain & vents by preparation of detailed layout drawing.
2. Overhead piping shall have a minimum vertical clearance of 2.3 metres above walkways and working areas and 7.5 metres above roadways unless otherwise approved by the BHEL-ENGINEER.
3. Provision shall be made while preparing piping layout to accept control valves, flow measurement element and any other on-line specialty or equipment. Sufficient upstream and downstream lengths shall be provided for flow measuring devices, control valves, and other specialties as required by the respective equipment manufacturer.
4. All the screwed valves and screwed connections on equipment shall be provided with unions to facilitate easy assembly / disassembly. Likewise, unions shall also be provided at suitable points on straight length of screwed pipelines.
5. The hangers and supports shall be spaced in accordance with standard engineering practice as outlined in applicable codes and standards.

#### **4.5.4 DIMENSIONAL STANDARDS**

1. Uniform dimensional standards for all piping components shall be employed to ensure compatibility with each other.
2. Nominal pipes sizes and pipe outside diameters shall generally be as per ANSI B 36.10.

#### **4.5.5 WELDING AND HEAT TREATMENT**

All heat treatment, welding, post and pre weld temperatures shall be as per the applicable ASME code.

|                                                                                   |                                               |                   |
|-----------------------------------------------------------------------------------|-----------------------------------------------|-------------------|
|  | <b>SPECIFICATION FOR<br/>MIXED BED SYSTEM</b> | SPEC. No:ROS-6154 |
|                                                                                   |                                               | REV: 00           |

#### 4.5.6 INSPECTION & CLEANING

All pipes shall be thoroughly cleaned & hydro-tested at shops for pressures as per standards and all erected piping shall be cleaned & tested at 1.5 times the design pressure.

All hot bent, forge-formed, fabricated and straight pipes shall be chemically cleaned, pickled or wire brush cleaned and purged with air blast or shot/grit blast to remove all sand and scale from the inner surface as applicable during manufacturing.

The Contractor shall carryout the following cleaning after hydro-test.

- a. All piping shall be mass flushed, in addition to the specific cleaning operations as described below, as required.
- b. Compressed air piping shall be blown by air.

#### 4.5.7 UNDERGROUND PROTECTION

Where pipelines are buried, underground protection shall be provided for the piping system by any one of the methods given below:

- a. Coal tar primer, coal tar enamel, inner wrap of fiberglass, final outer wrap of enamel impregnated fiberglass. Total thickness of coating shall not be less than 4.0 mm.
- b. With anti-corrosive tape of 4 mm thick conforming to IS-10221 and AWWA C 203-93.

### 4.6 VALVES

#### 4.6.1 DESIGN AND CONSTRUCTION FEATURES

The following consideration shall be made during the design / selection of valves for the MB System.

1. For the MB system diaphragm type valves shall be used for isolation / regulation purpose.
2. Bidder to select suitable material of construction for the valves based on the system requirement and shall be clearly indicated in the offer.
3. The end connection for the valves shall be of flanged type as per **ANSI B16.5 #150**.
4. Pressure rating of valves shall be of minimum 150 psi.

|                                                                                   |                                               |                   |
|-----------------------------------------------------------------------------------|-----------------------------------------------|-------------------|
|  | <b>SPECIFICATION FOR<br/>MIXED BED SYSTEM</b> | SPEC. No:ROS-6154 |
|                                                                                   |                                               | REV: 00           |

5. Necessary pneumatic actuated valves shall be provided for auto operation (option for manual opening and closing also provided) & regeneration of the plant as per P&ID.
6. The check valves shall be of wafer type swing check valve suitable for mounting between flanges.
7. The Material of Construction of the body and disc of check valve shall be SS 316/CPVC.
8. Cast steel valve shall be provided for compressed air system.
9. Bidder shall furnish the valves schedule in the attached format. (Annexure-5)

|                                                                                   |                                               |                   |
|-----------------------------------------------------------------------------------|-----------------------------------------------|-------------------|
|  | <b>SPECIFICATION FOR<br/>MIXED BED SYSTEM</b> | SPEC. No:ROS-6154 |
|                                                                                   |                                               | REV: 00           |

#### 4.6.2 VALVE - MATERIALS

| SL NO. | SERVICE                                                               | SIZE        | BODY/<br>BONNET                                         | DIAPHRAG<br>M / DISC /<br>BALL | STEM /<br>SHAFT                     | HAND<br>WHEEL        | VALVE<br>ENDS         |
|--------|-----------------------------------------------------------------------|-------------|---------------------------------------------------------|--------------------------------|-------------------------------------|----------------------|-----------------------|
| 2.1    | Frontal valves                                                        | ≥25NB       | IS 210<br>FG 200<br>ebonite lined<br>DIAPHRAGM<br>VALVE | EPDM                           |                                     | ASTM A47<br>Gr 32510 | FLANGED<br>#150 Class |
|        |                                                                       | ≤ 15<br>NB  | ASTM A312<br>TP 316                                     |                                |                                     | ASTM A47<br>Gr.32510 | SOCKET<br>WELDED      |
| 2.2    | DM WATER &<br>DG WATER<br>Pumps suction<br>& delivery<br>(Refer P&ID) | ≥65NB       | Butterfly<br>Valve<br>Body:CS                           | Disc :SS<br>Seat: EPDM         | SS 316                              |                      | FLANGED<br>#150 Class |
|        |                                                                       | ≤ 50<br>NB  | ASTM A312<br>TP 316                                     | SS316                          | SS 316                              | ASTM A47<br>Gr.32510 | SOCKET<br>WELDED      |
| 2.3    | INSTRUMENT<br>AIR SYSTEM<br>(BALL VALVES)                             | ≤ 50<br>NB  | ASTM B 62/<br>IS: 318 Gr 2                              | ASTM B 62 /<br>IS: 318 Gr2     | ASTM B 62<br>Gr A / IS:<br>320 HT 2 | ASTM A47<br>Gr 32510 | SCREW<br>TYPE         |
| 2.4    | CHEMICALS                                                             | ALL<br>SIZE | CPVC<br>ASTM D1784<br>PN 16<br>Pressure<br>rating       | EPDM                           |                                     | POLYPRO<br>PYLENE    | FLANGED /<br>SOCKET   |

- NOTE : 1 Testing of body and seat shall be as per ANSI B16.34
2. For water system with sizes greater than NB200 butterfly valves shall be used and shall conform to AWWA C-504.
  3. Flange drilling shall be as per ANSI B16.5, #150 psi.

#### 4.7 PAINTING

##### 4.7.1 GENERAL

(a) All the Equipment, steel structures and piping etc. shall be protected against external and internal (if any) corrosion by providing suitable painting as described below unless otherwise specified elsewhere. However, the surfaces of stainless steel, Galvanized steel, Gunmetal, brass, bronze, UPVC /CPVC pipes, HDPE pipes and non-metallic components shall not be applied with any painting.

(b) All painting shall be carried out in conformity with the paint manufacturer's recommendation.

(c) Codes and Standards:

|                                                                                   |                                               |                   |
|-----------------------------------------------------------------------------------|-----------------------------------------------|-------------------|
|  | <b>SPECIFICATION FOR<br/>MIXED BED SYSTEM</b> | SPEC. No:ROS-6154 |
|                                                                                   |                                               | REV: 00           |

Painting of equipment shall be carried out as per the specifications indicated below and shall confirm to the relevant IS specification for the material and workmanship.

The following applicable Indian Standards may be referred to carrying out the painting job:

|          |   |                                                                                                   |
|----------|---|---------------------------------------------------------------------------------------------------|
| IS : 5   | : | Colours for ready mixed paints and enamels                                                        |
| IS:1303  | : | Glossary of terms relating to paints.                                                             |
| IS:158   | : | Ready mixed paint, brushing, bituminous, black, Lead free, acid, alkali, water and heat resisting |
| IS:2074  | : | Ready mixed paint, air drying, red Oxide Zinc Chrome, priming                                     |
| IS:104   | : | Ready mixed paint, brushing, Zinc Chrome, priming                                                 |
| IS: 2932 | : | Enamel , synthetic, exterior (a) undercoating (b) finishing                                       |

(d) No painting or filler shall be applied until all repairs, hydrostatic test and final shop inspection are completed.

(e) All paints, when applied in a normal full coat, shall be free from runs, sags, wrinkles, patchiness, brush marks.

**(f) Finish paint coating of DFT 50 microns at site shall be done after completion of erection & Commissioning.**

#### **4.7.2 PREPARATION OF SURFACES**

All surfaces to be painted shall be thoroughly cleaned by sand /shot blasted to SA 2 1/2 finish as per Swedish standard SIS 055900 of all grease, oil, loose mill scale, dust, rust, slag and any other foreign matter. Mechanical cleaning by power tool and scrapping with steel wire brushes shall be adopted to clear the surfaces. However, in certain locations where power tool cleaning cannot be carried out, sand scrapping may be permitted with steel wire brushes and or abrasive paper. Cleaning with solvents shall be resorted to only in such areas where other methods specified above have not achieved the desired results. Cleaning with solvents shall be adopted only with the approval of the BHEL –Engineer.

#### **4.7.3 PRIMER PAINT**

One coat of Epoxy Zinc Phosphate primer shall be applied. After this first coat is dried up completely, second coat shall be applied. Primer shall be applied by brushing / spray to ensure a continuous film without 'holidays'.

No. of coats: 2

The total dry film thickness shall be minimum 100 microns.

|                                                                                   |                                               |                   |
|-----------------------------------------------------------------------------------|-----------------------------------------------|-------------------|
|  | <b>SPECIFICATION FOR<br/>MIXED BED SYSTEM</b> | SPEC. No:ROS-6154 |
|                                                                                   |                                               | REV: 00           |

#### 4.7.4 FINISH PAINT

First coat of Epoxy finish shall be applied. After this first coat dries up hard, the surface is wet scrubbed cutting down to smooth finish and ensuring that at no place the first coat is completely removed. After allowing the water to get evaporated completely, the second finish coat shall be applied.

No. of coats: 2

The total dry film thickness shall be minimum 100 microns.

(Above Painting procedure described is as per BHEL PRQA : 526 Rev. 01)

#### 4.7.6 SUGGESTED COLOUR CODES FOR PAINTING

| SI No. | ITEM / SERVICE                               | COLOUR              | IS-5 Grade          | Colour (Band) | IS-5 |
|--------|----------------------------------------------|---------------------|---------------------|---------------|------|
| 1      | Vessel & all other proprietary equipment     | Light gray          | 631                 | -             | -    |
| 2      | Pumps and motors etc.                        | Light gray          | 631                 | -             | -    |
| 3      | Tanks - indoor                               | Light gray          | 631                 | -             | -    |
|        | Structures, platforms, ladders and handrails | Dark Admiralty Grey | 632                 | -             | -    |
|        | Control & Relay panels                       | Light grey          | 631/ 7078 of IS1650 |               |      |

#### Notes :

1. This colour code basically refers to IS:2379 for piping with necessary modifications
2. Where band colour is specified, same shall be provided at 5 meter intervals on long uninterrupted lines and also adjacent to valves and junctions.

#### 4.8 VENDOR LIST FOR MECHANICAL ITEMS

Bidder to provide the vendor list for all major bought-out items along with the bid. However the following makes must be considered for items indicated as in the vendor list enclosed with the specification.

#### 5.0: ELECTRICAL, CONTROLS & INSTRUMENTATION

Electrical, control & Instrumentation requirements for the MB system is attached separately along with this specification **ROS: 4140**.

#### 6.0: TECHNICAL DETAILS FOR CIVIL WORKS:

Construction of civil building, equipment foundation with pockets and flooring etc for the MB system is not in bidder scope. However the bidder shall provide the equipment layout drawing along with bid.

|                                                                                   |                                               |                   |
|-----------------------------------------------------------------------------------|-----------------------------------------------|-------------------|
|  | <b>SPECIFICATION FOR<br/>MIXED BED SYSTEM</b> | SPEC. No:ROS-6154 |
|                                                                                   |                                               | REV: 00           |

Detailed construction drawing with foundation requirement like load details, foundation pockets etc, for all the equipments & tanks, flooring requirements, protective coatings, trenches for pipe routing & drains, cable routing etc., shall be furnished to BHEL for further construction immediately after order.

Any special requirement like handling arrangement, floor / trench protection etc. shall also be indicated in the drawings. All the plant drains & trenches are to be connected in a common trench and terminated near MB Plant boundary.

Foundation bolts, nuts & washers for all equipments shall be supplied by the bidder as per their offered equipment requirement. The complete grouting material and grouting of equipment are in the scope of bidder.

The approximate area & location are indicated in the enclosed lay out drawing. Bidder to accommodate the MB system with in the stipulated area only as indicated in the typical layout drawing attached along with this specification.

## **7.0 : SYSTEM PERFORMANCE**

The system performance guarantee and applicable penalty are detailed in this section.

### **7.1 PERFORMANCE GUARANTEE**

**7.1.1** The bidder shall guarantee all equipments for workmanship, materials and satisfactory performance. The guarantee for performance will cover individual items and systems including electrical for their ratings / outputs as well as for the integrated operation of equipment and its auxiliaries as a whole. On completion of satisfactory commissioning, the supplier shall conduct performance / acceptance tests on the equipment and system as a whole for demonstrating the guaranteed performance parameters specified. All instruments, gauges installed for the normal operation of equipment shall, be made use of during the acceptance test as far as possible. If additional instruments are required for the tests, these shall be brought by supplier free of cost and shall be taken back after performance test. All the calibrations and the consumables, hardware etc. required for calibration are in bidder's scope.

**7.1.2 The Performance guarantee tests shall be conducted & cover the following but not be limited to the rated parameters for smooth operation of complete MB system:**

- a. Degasser outlet water quality as per annexure-1
- b. MB system outlet Water quality as per annexure-1
- c. MB system net output and gross output between regeneration as per Annexure -1
- d. MB regeneration Chemical consumption including neutralizing chemical as per Annexure -1

|                                                                                   |                                               |                   |
|-----------------------------------------------------------------------------------|-----------------------------------------------|-------------------|
|  | <b>SPECIFICATION FOR<br/>MIXED BED SYSTEM</b> | SPEC. No:ROS-6154 |
|                                                                                   |                                               | REV: 00           |

- e. Power consumption for continuous operating equipment as per Annexure-3
- f. MB Regeneration time.
- g. Guaranteed water consumption for each regeneration of MB.
- h. Vibration and noise level of rotating equipment.

**7.1.2 Minimum 3 performance test run shall be conducted between regenerations for the guaranteed value of treated water quantity and chemical consumption of which 2 consecutive test results shall meet the guaranteed values specified above (a to h)**

#### 7.2.0 General

In addition to the guarantees mentioned above, the requirements of specifications on all guarantees as elaborated under relevant clauses of Technical Specifications should be met.

The equipments supplied shall be guaranteed for a minimum period of 12 (twelve) months from the date of successful commissioning of the units is after PG test. (excluding Resins). **Resins guarantee shall be as per spec. clause no: 4.3.3-w.**

Any part which proves defective either in design, materials / and / or manufacture within the above guarantee period shall be replaced at free of cost to the owner at site and the provision of this clause shall apply to the portions of the plant so replaced or renewed until the expiration of the guarantee period or from the date of replacement which ever is later.

### 8.0 SPARES

#### 8.1 Commissioning Spares:

The bidder should take care of this requirement since commissioning is under bidder's scope. The commissioning spares shall be delivered well in time before the start-up & commissioning of the plant. The tentative commissioning spares list for the individual equipment is indicated below. Over and above any additional requirements for trouble free commissioning of the equipment / system shall be included in the list. The price for the commissioning spares shall be included & indicated in the main supply. Any unutilized startup spares shall be handed over to the Owner.

The commissioning spares for the E,C &I portion are indicated in the **ROS 4140** vide CI no. 2.8 in page no. 53 of 53 which are to be given compulsorily as commissioning spares.

#### List of commissioning spares:

| Sl. No. | Description of the equipment | Description of spares | Qty                   | Remarks |
|---------|------------------------------|-----------------------|-----------------------|---------|
| 1       | MB vessel                    | Filter Nozzles        | 10% of total quantity |         |
| 2       | Ejector                      | Ejector nozzles       | 1set for each variant |         |
|         |                              |                       |                       |         |

|                                                                                   |                                               |                   |
|-----------------------------------------------------------------------------------|-----------------------------------------------|-------------------|
|  | <b>SPECIFICATION FOR<br/>MIXED BED SYSTEM</b> | SPEC. No:ROS-6154 |
|                                                                                   |                                               | REV: 00           |

## 8.2 MANDATORY SPARES:

The bidder shall supply the mandatory spares as per the list given below. The mandatory spares shall be supplied in a separate packing with due indication as mandatory spares along with the main supply well in time before start-up & commissioning of the Plant. Cost of mandatory spares shall be indicated separately and the same is considered for Bid Evaluation.

### List of Mandatory Spares:

| Sl. No. | Description of the equipment | Description of spares   | Qty                                     | Unit                                                    |
|---------|------------------------------|-------------------------|-----------------------------------------|---------------------------------------------------------|
| 01      | Degasser tower               | Pall rings              | 10% of total quantity                   |                                                         |
|         |                              | Fill support members    | 10% of total quantity                   |                                                         |
|         |                              | Water sealing fittings  | 10% of total quantity                   |                                                         |
| 02      | Degasser blower              | Blades/Impeller         | 2                                       | Set                                                     |
|         |                              | Shaft                   | 2                                       | Set                                                     |
|         |                              | Blower bearings         | 2                                       | Set                                                     |
| 03      | Mixed Bed unit               | Resin                   | 10% of total quantity<br>cation & anion | Min. 40 ltrs<br>cation &<br>Min. 70 ltrs<br>Anion resin |
|         |                              | Laterals                | 10% of total quantity                   |                                                         |
|         |                              | Strainers/Filter nozzle | 10% of total quantity                   |                                                         |
| 04      | Acid unloading pump          | Impeller                | 1                                       | No                                                      |
|         |                              | Shafts                  | 1                                       | No                                                      |
|         |                              | Bearings                | 1                                       | Set                                                     |
|         |                              | Shaft sleeves           | 1                                       | Set                                                     |
|         |                              | Bearing bushings        | 1                                       | Set                                                     |
|         |                              | Mechanical seal         | 1                                       | Set                                                     |
|         |                              | Wearing rings           | 1                                       | Set                                                     |
|         |                              | Fasteners               | 1                                       | Set                                                     |
| 05      | Alkali unloading pumps       | Impeller                | 1                                       | No                                                      |
|         |                              | Shafts                  | 1                                       | No                                                      |
|         |                              | Bearings                | 1                                       | Set                                                     |
|         |                              | Shaft sleeves           | 1                                       | Set                                                     |
|         |                              | Bearing bushings        | 1                                       | Set                                                     |
|         |                              | Mechanical seal         | 1                                       | Set                                                     |
|         |                              | Wearing rings           | 1                                       | Set                                                     |
|         |                              | Fasteners               | 1                                       | Set                                                     |
| 06      | Neutralizing system pumps    | Impeller                | 1                                       | No                                                      |
|         |                              | Shafts                  | 1                                       | No                                                      |
|         |                              | Bearings                | 1                                       | Set                                                     |
|         |                              | Shaft sleeves           | 1                                       | Set                                                     |
|         |                              | Bearing bushings        | 1                                       | Set                                                     |
|         |                              | Mechanical seal         | 1                                       | Set                                                     |
|         |                              | Wearing rings           | 1                                       | Set                                                     |
|         |                              | Fasteners               | 1                                       | Set                                                     |
| 07      | DM Regeneration              | Impeller                | 1                                       | No                                                      |

|                                                                                   |                                               |                   |
|-----------------------------------------------------------------------------------|-----------------------------------------------|-------------------|
|  | <b>SPECIFICATION FOR<br/>MIXED BED SYSTEM</b> | SPEC. No:ROS-6154 |
|                                                                                   |                                               | REV: 00           |

|    |                      |                  |   |     |
|----|----------------------|------------------|---|-----|
|    | pump                 | Shafts           | 1 | No  |
|    |                      | Bearings         | 1 | Set |
|    |                      | Shaft sleeves    | 1 | Set |
|    |                      | Bearing bushings | 1 | Set |
|    |                      | Mechanical seal  | 1 | Set |
|    |                      | Wearing rings    | 1 | Set |
|    |                      | Fasteners        | 1 | set |
| 08 | Mixed Bed Feed pumps | Impeller         | 1 | No  |
|    |                      | Shafts           | 1 | No  |
|    |                      | Bearings         | 1 | Set |
|    |                      | Shaft sleeves    | 1 | Set |
|    |                      | Bearing bushings | 1 | Set |
|    |                      | Mechanical seal  | 1 | Set |
|    |                      | Wearing rings    | 1 | Set |
|    |                      | Fasteners        | 1 | set |

**Note :** Mandatory spares for E C&I items, please refer attached specification ROS:4140.

#### **9.0 : ERECTION , COMMISSIONING, PG TEST & HANDING OVER:**

Erection, commissioning, trial operation, Performance Guarantee (PG) test and handing over of the MB system is attached separately as **Part-2** along with this specification.

#### **10.0 : DOCUMENTATION :**

The documentation during bid and post order stage shall meet the following requirements.

1. Hard copies of all documents and drawings during bid stage to be submitted in **duplicate for approval**
2. Hard copies of all final documents, drawings, erection and O&M manual etc., shall be submitted in bound folder in **duplicate**.
3. Soft copies of all final documents in MS word / MS office in the form of CD – 1 set
4. Soft copies of all final calculations in MS excel /MS officer in the form of CD – 1set
5. Soft copies of all final drawings in Auto Cad, latest version in the form of CD – 1set

#### **10.1 : DOCUMENTS TO BE SUBMITTED ALONG WITH BID:**

The following drawings / documents are to be enclosed along with the bid for scrutiny.

1. Complete confirmation to our specification by signing in each page with seal.
2. Duly filled up Data sheets enclosed - Annexure – 1 to 5
3. Technical write-up giving details of equipment, sequential operation, interlocks / control requirement.
4. Resin quantity calculations along with resin literature and characteristic curves.
5. Resin regeneration calculations.
6. Resin regeneration sequence with flow rate, duration, effluent details etc.,
7. Preliminary P& I diagram
8. Preliminary Equipment layout drawing

|                                                                                   |                                               |                   |
|-----------------------------------------------------------------------------------|-----------------------------------------------|-------------------|
|  | <b>SPECIFICATION FOR<br/>MIXED BED SYSTEM</b> | SPEC. No:ROS-6154 |
|                                                                                   |                                               | REV: 00           |

9. Typical internal arrangement drawing
10. Utility requirements like instrument air, service air and service water for regeneration and rinse etc.
11. Typical Quality Plan.
12. Preliminary civil requirements.
13. PLC I/O list.
14. Details of Pneumatic Actuator
15. Un-priced commercial offer on the scope of supply
16. Un-priced commercial offer for the recommended spares list

**Note:**

1. In case of any deviation, the Bidder shall indicate the deviation, clause by clause in the deviation format attached in **Annexure - 5**. If there is no deviation “NIL” statement shall be furnished. In the absence of the non attachment of this **Annexure-5**, it will be construed that the bid confirms strictly to the specification. Acceptance or rejection of the offer with or without deviations (either fully or partially) is sole discretion of the purchaser without seeking further clarification from the bidder.
2. Bidder to note that failing to submit the above, the bid shall be considered as incomplete and offers are liable for rejection.

**10.2 : DOCUMENTS TO BE SUBMITTED AFTER ORDER:**

The following documents / Drawings and data to be furnished for BHEL / customer approval.

**Phase – 1 within 3 weeks from the date of purchase order receipt.**

1. Foundation drawings indicating foundation design, load data, anchor bolt location, pocket details, floor & trenches etc.
2. Activity chart / Bar Chart and schedules for drawing submission, manufacturing, erection and commissioning
3. P and I Diagram including pipe sizes and terminal points.
4. Resin quantity calculations along with resin literature and characteristic curves.
5. Resin regeneration calculations and resin regeneration sequence with flow rate, duration, effluent details etc.,
6. Design calculation and thickness calculations for all major vessels and tanks as per code.
7. Generated regeneration water quantity / quality (TDS & pH and major constituents) of each regeneration
8. Duly filled Data sheets enclosed – Annexure 1 to 2
9. Equipment layout showing equipment details, headroom, size.
10. Technical Write-up and design basis
11. MB system “Control Description” write-up including sequential operation, controls, interlocks, protection, annunciation etc.
12. Quality Plan and field quality checks, stage inspection etc. for the above equipments & system

|                                                                                   |                                               |                   |
|-----------------------------------------------------------------------------------|-----------------------------------------------|-------------------|
|  | <b>SPECIFICATION FOR<br/>MIXED BED SYSTEM</b> | SPEC. No:ROS-6154 |
|                                                                                   |                                               | REV: 00           |

Phase – 2 within 5 weeks from the date of purchase order receipt.

13. Detailed construction and cross-sectional drawings for the following:
  - a. Vessel fabrication & assembly with Bill of material ( BOM)
  - b. Nozzle and Orientation
  - c. Internals ( Collector & distributors)
  - d. Resin depth, filling details and preservation details
  - e. Any other accessories with bill of materials.
14. Detailed assembly & cross sectional drawings with bill of material for pump & motor.
15. Detailed assembly & cross sectional drawings with bill of material for blower, motor, V-belt, pulley, base frame, valves, silencers etc., with lifting arrangement for blower and motor.
16. Performance curves for pumps & blowers
  - a. Flow Vs Head
  - b. Flow Vs efficiency
  - c. Flow Vs Power
  - d. Flow Vs NPSH
17. Duly filled Data sheets enclosed – Annexure 3 to 5
18. Un-priced purchase order copies of the equipment & accessories ordered on sub-vendors (The list of approved sub-vendors are given in section -----)
19. Detailed assembly & cross sectional drawing of valves.
20. Instrument schedule.
21. Detailed PLC i/O list

phase – 3 With in 8 weeks from the date of purchase order receipt for information.

22. Isometric drawing of pipe segments.
23. Erection Manual indicating
  - a. Erection / installation instruction of equipments.
  - b. Log sheet containing Stage check parameters & clearance
  - c. Log sheet for Alignment Check of pump & motor
  - d. Field quality checks
24. Performance Test procedure
25. As-built manufacturing drawing of the equipment and total system with bill of materials ( BOM)
26. All the documents called in Electrical specification.
27. Detailed bill of materials for all the items with make / detailed vendor name etc.
28. All the documents called in Electrical specification

**10.3 : DOCUMENTS TO BE SUBMITTED BEFORE DESPATCH:**

The following documents/Drawings are to be furnished for BHEL / customer review for information and before dispatch.

phase – 4

1. Pump & Blower performance test reports
2. Pump & blower performance guarantee certificates

|                                                                                   |                                               |                   |
|-----------------------------------------------------------------------------------|-----------------------------------------------|-------------------|
|  | <b>SPECIFICATION FOR<br/>MIXED BED SYSTEM</b> | SPEC. No:ROS-6154 |
|                                                                                   |                                               | REV: 00           |

3. Necessary material test certificates, hydraulic test certificates for all major items.
4. Operation and maintenance manual indicating, Operating procedure for start-up, normal operation, shut down and emergency shut down. Maintenance instruction & assembly
5. Lubrication chart
6. Electrical equipment layout, Cable trench layout, cable routing, cable schedules and cable termination details.
7. MB System Logic diagram & Sequential Flow Chart (SFC) for PLC
8. Cable interconnection diagram for cables up to junction box & cable schedule.
9. Test Certificates for all the supplied instruments.
10. List of alarm, interlock & trip set points
11. Installation drawings for instruments
12. Wiring drawings & GA drawings for Local Panels, junction boxes.
13. As built drawings

**Note: Bidder to confirm in their offer that these details called in 13.1 & 13.2. will be provided.**

#### **11. ATTACHMENTS:**

1. Preliminary P & ID Drg No. : 1-WT-220-00711 Rev.00
2. Legend for P & ID Drg. No. : 2-WT-220-00211 Rev.01
3. Typical layout Drawing No. : 1-WT-220-00712 Rev.00
4. Specification for Electrical, Control & Instrumentation ROS:4140
5. Vendors list No. 4-WT-220-00488
6. Painting specification PRQA – 526 Rev.01

|                                                                                   |                                               |                   |
|-----------------------------------------------------------------------------------|-----------------------------------------------|-------------------|
|  | <b>SPECIFICATION FOR<br/>MIXED BED SYSTEM</b> | SPEC. No:ROS-6154 |
|                                                                                   |                                               | REV: 00           |

## 12. Outlet Guarantee Parameter

Annexure-1

### I DEGASSER OUTLET WATER QUALITY

| Sl.No. | Description                        | Unit  | Values |
|--------|------------------------------------|-------|--------|
| 1      | Carbon di Oxide as CO <sub>2</sub> | ppm   |        |
| 2      | Conductivity                       | μS/cm |        |
| 3      | pH                                 |       |        |

### II MIXED BED OUTLET WATER QUALITY

| Sl.No. | Description                               | Unit  | Values |
|--------|-------------------------------------------|-------|--------|
| 1      | pH                                        |       |        |
| 2      | Conductivity                              | μS/cm |        |
| 3      | SiO <sub>2</sub> as SiO <sub>2</sub>      | ppm   |        |
| 4      | Sodium as Na                              | ppm   |        |
| 5      | Total Hardness as CaCO <sub>3</sub>       | ppm   |        |
| 6      | Organic matter as KMnO <sub>4</sub> value | ppm   |        |
| 7      | Carbon Di Oxide                           | ppm   |        |

### III MB OUTPUT BETWEEN EACH REGENERATION

| Sl.No. | Description | Unit | Values |
|--------|-------------|------|--------|
| 1      | NET         | Cu.M |        |
| 2      | GROSS       | Cu.M |        |

### IV CHEMICAL REQUIREMENT PER REGENERATION INCLUDING NEUTRALIZATION

| Sl.No. | Description | Unit     | Values |
|--------|-------------|----------|--------|
| 1      | HCl - 30%   | kg/regen |        |
| 2      | NaOH - 48%  | Kg/regen |        |

### V MIXED BED RESIN (Anion & Cation)

| Sl.No. | Description         | Unit  | Cation / Anion |
|--------|---------------------|-------|----------------|
| 1      | Quantity per vessel | Ltrs  | /              |
| 2      | Life                | Years | /              |

|                                                                                   |                                               |                   |
|-----------------------------------------------------------------------------------|-----------------------------------------------|-------------------|
|  | <b>SPECIFICATION FOR<br/>MIXED BED SYSTEM</b> | SPEC. No:ROS-6154 |
|                                                                                   |                                               | REV: 00           |

## Annexure-2

### EQUIPMENT DATA SHEET

- |     |                                                 |     |                                                                                            |
|-----|-------------------------------------------------|-----|--------------------------------------------------------------------------------------------|
| 1.0 | EQUIPMENT                                       |     | : DEGASSER TOWER WITH TANK &<br>: ACCESSORIES                                              |
| 2.0 | Application                                     |     | : To reduce CO <sub>2</sub> level in the permeate<br>: water from R.O. Desalination Plant. |
| 3.0 | Quantity                                        |     | : ONE (1) set                                                                              |
| 4.0 | Degassed water Tank Capacity                    |     | : 20 Cu.M (usable volume)                                                                  |
|     | a. Design Code                                  |     | : IS 2825                                                                                  |
|     | b. Corrosion allowance Shell/Ends mm            |     | :                                                                                          |
|     | c. Size ( dia x Ht)                             | mm  | :                                                                                          |
|     | d. Thickness(Shell &Ends)                       | mm  | :                                                                                          |
|     | e. Material of Construction                     |     | :                                                                                          |
|     | f. Internal protection                          |     | :                                                                                          |
|     | g. Shore hardness                               |     | :                                                                                          |
|     | h. Lining Material                              |     | :                                                                                          |
|     | i. Design pressure                              | bar | :                                                                                          |
|     | j. Test Pressure                                | bar | :                                                                                          |
|     | k. Nozzles - Outlet to MB feed Pump             |     | :                                                                                          |
|     | - Drain                                         |     | :                                                                                          |
|     | - Sampling point                                |     | :                                                                                          |
|     | - Manhole                                       |     | :                                                                                          |
| 5.0 | Tower particulars                               |     |                                                                                            |
|     | a. Type                                         |     | :                                                                                          |
|     | c. Make                                         |     | :                                                                                          |
|     | d. Model                                        |     | :                                                                                          |
|     | e. Flow rate in M <sup>3</sup> /hr - design/Max |     | :                                                                                          |
|     | f. Design Code                                  |     | :                                                                                          |
|     | g. Corrosion allowance Shell                    | mm  | :                                                                                          |
|     | h. Material of Construction                     |     | :                                                                                          |
|     | i. Dia x Height                                 | mm  | :                                                                                          |
|     | j. Thickness Shell/Ends                         | mm  | :                                                                                          |

|                                                                                   |                                               |                   |
|-----------------------------------------------------------------------------------|-----------------------------------------------|-------------------|
|  | <b>SPECIFICATION FOR<br/>MIXED BED SYSTEM</b> | SPEC. No:ROS-6154 |
|                                                                                   |                                               | REV: 00           |

k.. Surface Flow rate in m/sec-Design/Max:

- l. **Velocity** :
- m. **Air to water ratio** :
- n. Internal Protection :
- o. External protection :
- p. Design Pressure :
- q. Packing material of tower :
- r. Quantity of packing materials :
- s. Packing height :
- t. Inlet Nozzle size, type, rating :
- u. Outlet nozzle size, type, rating :
- v. Level switches :
- w. MOC of Rasching Ring :

#### 6.0 DEGASSER BLOWER

- a. Qty. offered :
- b.Capacity in m<sup>3</sup>/hr :
- c. Head in mm WC :
- d. Efficiency :
- e. Make :
- f. Type :
- g. MOC of Blower - Casing :
- Impeller :
- Shaft :
- h. Power rating of motor in KW :
- i. Speed RPM :
- j. Total weight of DGT assembly :
- k. Noise levelmeasured at 1 m distance :



**SPECIFICATION FOR  
MIXED BED SYSTEM**

SPEC. No:ROS-6154

REV: 00

7.0 MIXED BED UNIT

- a. Quantity :
- b. Type :
- c. Net output, m<sup>3</sup>/hr :
- d. Gross output between regeneration in M3 }  
excluding regeneration hrs. }
- e. **Productive output between each regeneration } :**  
**excluding regeneration hrs. in M3 }**
- f. Operating cycle excluding regen.hrs :
- g. Duration of regeneration hrs :  
Regeneration type for Cation :  
Regeneration type for Anion :
- h. Material of Construction of Vessel :
- i. Diameter -shell mm :
- j Thickness -shell & Dish Ends mm :
- k. Design Flow Velocity m<sup>3</sup>/hr/m<sup>2</sup> :
- l. Maximum velocity permitted m/s :
- m. Internal protection :
- n. Shore hardness :  
- Lining Material :
- o. External protection :
- p. Design Code :
- q. Corrosion allowance-Shell/DE mm :
- r. Thinning allowance-DE mm :
- s. Design Pressure :
- t. Test Pressure :
- u. Vessel dia x st. height x tot. ht mm :
- v. Resin bed ht. Anion/Cation mm :
- w. Free Board % :
  
- x. Nozzles size & rating :

|                                                                                   |                                               |                   |
|-----------------------------------------------------------------------------------|-----------------------------------------------|-------------------|
|  | <b>SPECIFICATION FOR<br/>MIXED BED SYSTEM</b> | SPEC. No:ROS-6154 |
|                                                                                   |                                               | REV: 00           |

- 
- 
- 
- 
- 

- y. No.of sight glasses & size :
- z. No of manholes & size :
- aa. Details about distributor nozzles :

7.1 MIXED BED UNIT RESIN

- |                                                                          |          |                                    |
|--------------------------------------------------------------------------|----------|------------------------------------|
|                                                                          | : CATION | ANION                              |
| a. Resin make & Model No.                                                | :        |                                    |
| b. Resin quantity, M3                                                    | :        |                                    |
| c. Resin Type                                                            | :        |                                    |
| d. Bed Depth , M                                                         | :        |                                    |
| e. Resin Life, years                                                     | :        |                                    |
| f. Ionic load as CaCO3                      mg/l                         | :        |                                    |
| g. Regeneration level,                      kg/m3                        | :        |                                    |
| h. Operating Exchange Capacity}                      :                   |          |                                    |
| As CaCO3,                      }                      kg/m3              | :        |                                    |
| i. Derated Exchange Capacity , kg/m3                                     | :        |                                    |
| j. Qty of Acid 30% & NaOH 48%                                            | :        |                                    |
| k. Time required / duration for Complete<br>Regeneration                 | :        |                                    |
| l. Head loss through exchanger,                      m                   | :        |                                    |
| m. Resin Trap provided                                                   | :        |                                    |
| n. Attrition loss of resin per annum                                     | :        |                                    |
| o. Quantity of DM water required per<br>Regeneration with break up cycle | :        |                                    |
| p. Time required to complete<br>one regeneration                         | :        | Bidder to provide<br>( max. 4 hrs) |

|                                                                                   |                                               |                   |
|-----------------------------------------------------------------------------------|-----------------------------------------------|-------------------|
|  | <b>SPECIFICATION FOR<br/>MIXED BED SYSTEM</b> | SPEC. No:ROS-6154 |
|                                                                                   |                                               | REV: 00           |

|     |                                                          |   |               |              |
|-----|----------------------------------------------------------|---|---------------|--------------|
| 7.3 | <u>REGENERATION CHEMICAL</u>                             | : | <u>CATION</u> | <u>ANION</u> |
|     | a. Type & Specification                                  | : |               |              |
|     | b. Chemical Concentration                                | : |               |              |
|     | c. Grade                                                 | : |               |              |
|     | d. Quantity required for each<br>Regeneration on % basis | : |               |              |
|     | e. Protection from outside if any                        | : |               |              |

|     |                                                                                          |   |                        |                           |
|-----|------------------------------------------------------------------------------------------|---|------------------------|---------------------------|
| 7.4 | <u>Measuring Tanks</u>                                                                   | : | Acid measuring<br>Tank | Alakali measuring<br>Tank |
|     | 1 Quantity                                                                               | : |                        |                           |
|     | 2 Type                                                                                   | : |                        |                           |
|     | 3 Capacity                   Its                                                         | : |                        |                           |
|     | 4 Dimensions ( dia x ht)                                                                 | : |                        |                           |
|     | 5 MOC                                                                                    | : |                        |                           |
|     | 6. Thicknes bottom, top circumference                                                    | : |                        |                           |
|     | 6 Internal protection, if any                                                            | : |                        |                           |
|     | 7 Thickness of lining                                                                    | : |                        |                           |
|     | 8 Lining Material                                                                        | : |                        |                           |
|     | 9 Agitator quantity                                                                      | : |                        |                           |
|     | 10 Agitator M.O.C                                                                        | : |                        |                           |
|     | 11. Resin used for inner layer                                                           | : |                        |                           |
|     | 12. Resin used for outer layer                                                           | : |                        |                           |
|     | 13. The glass content of inner layer<br>% by weight.                                     | : |                        |                           |
|     | 14. The glass content of filament wound }<br>structural layer           % by weight    } | : |                        |                           |
|     | 16. Level Indicator make and details                                                     | : |                        |                           |

**8.0 DATA SHEET FOR MB FEED / MB REGENERATION CENTRIFUGAL PUMP**

|                                |   |         |           |            |
|--------------------------------|---|---------|-----------|------------|
| <b>A. PUMP</b>                 | : | MB FEED | MB REGEN. | N-pit pump |
| <b>I. TECHNICAL PARAMETERS</b> |   |         |           |            |
| a. Make                        | : |         |           |            |
| b. Model                       | : |         |           |            |



**SPECIFICATION FOR  
MIXED BED SYSTEM**

SPEC. No:ROS-6154

REV: 00

c. Fluid details

- Medium handled :
- PH range :
- Specific Gravity :
- TDS/Chloride range ppm :
- Temperature range Deg.C :

d. Design flow at rated speed cu.m/hr:

e. Mini. & Max continuous flow M3/Hr :

f. Total Head developed @design flow mWC :

g. Shut-off head mWC :

h. NPSH required (minimum) mWC :

i. Design Pressure kg/cm2:

j. Hydraulic test pressure kg/cm2:

k. Pump efficiency at duty point % :

l. Pump efficiency at maximum flow % :

m. Pump shaft power reqd. at duty point KW :

n. Maximum shaft power required KW :

o. Selected Motor KW :

p. Rated speed & Critical speed rpm :

q. GD2 of the pump kg-m2 :

r. Pump performance curve ref. Nos :

s. Upward / Downward thrust :

t. Operating flow range from duty point % :

u. Noise level at duty range dbA :

v. Vibration level

- Displacement microns (peak to peak)mm:
- Velocity (peak) mm/sec:

w. Balancing quality as per ISO 1940 STD :

x. Rotation of shaft viewing from drive end :

y. Tolerance on guaranteed efficiency & head at rated flow and speed :



**SPECIFICATION FOR  
MIXED BED SYSTEM**

SPEC. No:ROS-6154

REV: 00

**II. CONSTRUCTION DETAILS**

|                                               | <b>MB FEED</b> | <b>MB REGEN</b> | <b>N-pit pump</b> |
|-----------------------------------------------|----------------|-----------------|-------------------|
| a. Orientation :                              | Horizontal     | Horizontal      | Horizontal        |
| b. Suction / Discharge nozzle                 |                |                 |                   |
| - Size mm :                                   | /              | /               |                   |
| - Rating psi :                                | /              | /               |                   |
| - Flange drilling standard :                  | /              | /               |                   |
| - Nozzle Orientation looking from drive end : | /              | /               |                   |
| - Material :                                  | /              | /               |                   |
| c. Material of Construction / Make            |                |                 |                   |
| - Pump Casing :                               |                |                 |                   |
| - Impeller :                                  |                |                 |                   |
| - Shaft :                                     |                |                 |                   |
| - Shaft Sleeve :                              |                |                 |                   |
| - Wear rings :                                |                |                 |                   |
| - Diffuser :                                  |                |                 |                   |
| - Mechanical Seal :                           |                |                 |                   |
| - Bearing housing :                           |                |                 |                   |
| - Fasteners :                                 |                |                 |                   |
| - Others if any :                             |                |                 |                   |
| d. No.of stages :                             |                |                 |                   |
| e. Impeller type :                            |                |                 |                   |
| f. Impeller diameter Trimmed / Untrimmed :    |                |                 |                   |
| g. BEARINGS                                   |                |                 |                   |
| - Type :                                      |                |                 |                   |
| - Make :                                      |                |                 |                   |
| - Lubrication oil spec. :                     |                |                 |                   |
| - Lubricaion oil qty / pump :                 |                |                 |                   |
| h. Mechanical seal                            |                |                 |                   |
| - Type :                                      |                |                 |                   |
| - Make :                                      |                |                 |                   |
| - Model :                                     |                |                 |                   |



**SPECIFICATION FOR  
MIXED BED SYSTEM**

SPEC. No:ROS-6154

REV: 00

- Drawing No. :

i. Pump dimension L x W x H :

j. Pump Weight :

**III. COUPLING**

a. Type :

b. Make & Model No. :

c. Coupling guard material :

d. Dimension detail with BOM enclosed :

e. Weight :

**IV. BASE FRAME AND ACCESSORIES**

a. Material :

b. Dimension detail mm :

c. Weight kg :

d. Foundation Bolt - Size & Qty mm & Nos. :

- MOC :

**V. GENERAL**

a. Shipping package dimension mm :

b. Total Assembly / Shipment weight kg :

c. List of Special tools :

*Accessories details* :



**SPECIFICATION FOR  
MIXED BED SYSTEM**

SPEC. No:ROS-6154

REV: 00

**Anexure-3**

**ELECTRICAL POWER CONSUMPTION**

| Sl. No. | Eqpt.. Description                | Qty |    | Drive rating KW | Conn load. Load KW | Power consumption KW** | Voltage, Phase |
|---------|-----------------------------------|-----|----|-----------------|--------------------|------------------------|----------------|
|         |                                   | W   | SB |                 |                    |                        |                |
| A       | FOR CONTINUOUS OPERATING EQPT.    |     |    |                 |                    |                        |                |
| 1       |                                   |     |    |                 |                    |                        |                |
| 2       |                                   |     |    |                 |                    |                        |                |
| 3       |                                   |     |    |                 |                    |                        |                |
| 4       |                                   |     |    |                 |                    |                        |                |
| 5       |                                   |     |    |                 |                    |                        |                |
| 6       |                                   |     |    |                 |                    |                        |                |
| 7       |                                   |     |    |                 |                    |                        |                |
|         | Sub total of A                    |     |    |                 |                    |                        |                |
| B       | FOR INTERMITTENT OPERATING EQPTS. |     |    |                 |                    |                        |                |
| 1       |                                   |     |    |                 |                    |                        |                |
| 2       |                                   |     |    |                 |                    |                        |                |
| 3       |                                   |     |    |                 |                    |                        |                |
| 4       |                                   |     |    |                 |                    |                        |                |
| 5       |                                   |     |    |                 |                    |                        |                |
|         | Grand Total                       |     |    |                 |                    |                        |                |

Note:1. Power consumption for continuous operating equipment will be considered for bid evaluation and Guarantee purpose  
W – Working                      SB – Standby



**SPECIFICATION FOR  
MIXED BED SYSTEM**

SPEC. No:ROS-6154

REV: 00

**Annexure-4**

**VALVES SCHEDULE - DATA SHEET**

| Sl.No. | Application         | Type | Size | Pr. Rating<br>Bar | Qty. | MOC of wetted Parts |                     |            |        | ACTUATOR<br>DETAILS |
|--------|---------------------|------|------|-------------------|------|---------------------|---------------------|------------|--------|---------------------|
|        |                     |      |      |                   |      | Body                | Disc /<br>Diaphragm | Stem/sahft | Lining |                     |
| I      | MANUAL<br>VALVES    |      |      |                   |      |                     |                     |            |        |                     |
|        |                     |      |      |                   |      |                     |                     |            |        |                     |
|        |                     |      |      |                   |      |                     |                     |            |        |                     |
|        |                     |      |      |                   |      |                     |                     |            |        |                     |
|        |                     |      |      |                   |      |                     |                     |            |        |                     |
|        |                     |      |      |                   |      |                     |                     |            |        |                     |
|        |                     |      |      |                   |      |                     |                     |            |        |                     |
| II     | PNEUMATIC<br>VALVES |      |      |                   |      |                     |                     |            |        |                     |
|        |                     |      |      |                   |      |                     |                     |            |        |                     |
|        |                     |      |      |                   |      |                     |                     |            |        |                     |
|        |                     |      |      |                   |      |                     |                     |            |        |                     |
|        |                     |      |      |                   |      |                     |                     |            |        |                     |
|        |                     |      |      |                   |      |                     |                     |            |        |                     |
|        |                     |      |      |                   |      |                     |                     |            |        |                     |



**SPECIFICATION FOR  
MIXED BED SYSTEM**

SPEC. No:ROS-6154

REV: 00

**ANNEXURE - 5**

**TECHNICAL DEVIATIONS**

| <i>Sl. No</i> | <i>Section no.</i> | <i>Clause No.</i> | <i>Page / No.</i> | <i>Specification</i> | <i>Statement of Deviations/variations</i> | <i>Reason for Deviation</i> | <i>cost of withdrawal</i> |
|---------------|--------------------|-------------------|-------------------|----------------------|-------------------------------------------|-----------------------------|---------------------------|
|               |                    |                   |                   |                      |                                           |                             |                           |
|               |                    |                   |                   |                      |                                           |                             |                           |
|               |                    |                   |                   |                      |                                           |                             |                           |
|               |                    |                   |                   |                      |                                           |                             |                           |
|               |                    |                   |                   |                      |                                           |                             |                           |
|               |                    |                   |                   |                      |                                           |                             |                           |
|               |                    |                   |                   |                      |                                           |                             |                           |

|                                                                                   |                                               |                    |
|-----------------------------------------------------------------------------------|-----------------------------------------------|--------------------|
|  | <b>SPECIFICATION FOR<br/>MIXED BED SYSTEM</b> | SPEC. No.:ROS 6154 |
|                                                                                   |                                               | REV: 00            |

**SECTION – 9**  
**ERECTION, COMMISSIONING, PG TEST, AND HANDING  
OVER**

|                                                                                   |                                               |                    |
|-----------------------------------------------------------------------------------|-----------------------------------------------|--------------------|
|  | <b>SPECIFICATION FOR<br/>MIXED BED SYSTEM</b> | SPEC. No.:ROS 6154 |
|                                                                                   |                                               | REV: 00            |

## 1.0 SCOPE OF SERVICES

The scope of Erection and Commissioning of systems {De-Gasser System and Mixed Bed (MB) System} comprises of collection of materials and equipment from site stores, transportation to erection spot, erection of complete system including site fabrication if any, stage clearance, testing, commissioning and PG (Performance Guarantee) Test. Further, and handling over of these systems. Please refer the Note to Clause No. 1.1 Scope of Supply and Services in the main specification (Page No. 2 of 47).

The equipment after inspection at manufacturer's works shall be transported to BHEL site and shall be delivered to the BHEL stores as in supply specification. Unloading of the materials at Site stores & storing of the materials is in BHEL-PSSR's scope. The applicable materials shall be drawn from BHEL stores as per the relevant procedure. The equipment shall be erected sequentially and shall be interconnected with the applicable piping and valve system. Necessary Hydro testing of piping shall also be carried out. All the dummy flanges etc. required for it are under the scope of bidder.

### 1.1 **The following are the scope of major equipment for the erection & commissioning of the mixed bed system at site.**

- a. 1 x 100% MSRL Degasser tower with all internals & accessories
- b. 1 x 100% MSRL Degassed Water Storage Tank.
- c. 2 x 100% (1W + 1S) of Degasser Blowers with motors, Air filter box (suction) & accessories
- d. 1 x 100% (1W) MB Unit along with all accessories, internals etc.,
- e. 1 set of Cat ion & anion resin for MB system
- f. 2 x 100 % (1W+1S) Mixed Bed (MB) feed pumps with motors and all accessories.
- g. 2 x 100% (1W+1S) MB regeneration Pumps with motors and all accessories
- h. 2 x 100% (1W+1S) MB Blowers with motors and all accessories for MB regeneration
- i. 1 x 100% Acid Measuring Tank (AMT), ejector & acc. etc for MB regeneration
- j. 1 x 100% Caustic Dilution Tank (CDT) with agitator, ejector & acc. etc. for MB regeneration.
- k. 1 x 100% Bulk Acid Storage Tank (MSRL) with 2 x 100% acid unloading pumps with motors along with interconnecting piping & accessories.
- l. 1 x 100% Bulk Caustic Storage Tank with 2 x 100% caustic unloading pumps with motors along with interconnecting piping & accessories.
- m. 1 set of MB frontal piping (CPVC) with pneumatic operated diaphragm valves.



**SPECIFICATION FOR  
MIXED BED SYSTEM**

SPEC. No.:ROS 6154

REV: 00

- n. 1 set of interconnecting piping/ducting system including valves and accessories etc. for the following areas as per the **enclosed P &ID**.
- Degasser system to MB feed pumps
  - Degasser blowers to degasser(ducting)
  - MB feed pumps to MB vessel
  - MB blowers to MB vessel
  - MB regeneration pumps suction piping from DM Water storage tank upto pumps
  - MB regeneration pumps discharge to MB system
  - Piping for bulk chemical storage system (unloading pumps to tanks & from tanks to AMT/CDT)
  - Bulk chemical storage system to Neutralization pit.
  - AMT/CDT area to MB system.
  - MB outlet piping from vessel to outside of RO-DM plant building.
  - Between N.pit, priming chamber, N.pit effluent transfer pumps and discharge piping till the terminal point.
- o. 2 x 100% (1W+1S) N-pit effluents transfer pumps with motors and all accessories
- p. 2x100% (1W+1S) priming chamber for above N-pit transfer pump & diffuser piping arrangement for N-pit with all accessories
- q. 1 set of necessary foundation bolts with fasteners for all the equipments.
- r. 1 set of Electrical, Controls & Instrumentation as per specification & PID & ROS: 4041
- s. **Optional price for O&M for three months after PG Test ( this will not be considered for tender evaluation)**

The above quantity and the details given are only indicative. However the bidder shall supply required quantity and carry out the erection of all the items to meet the system requirement as complete without any commercial implication to BHEL.

- 2.0 The Intent of this specification is to provide erection, commissioning , trial run, PG Test , and handing over of MB for execution of projects according to most modern and proven techniques and codes. It is not the intent to specify completely herein, all aspects of the entire system. Nevertheless, the entire system shall conform in all respects to high standards of engineering, design and workmanship and shall be capable of performing in continuous commercial operation. The contract services towards installation of the Plant shall not relieve the contractor of the responsibility of providing such services, facilities to complete the project of portion of project awarded to him. The quoted rate shall deem to be inclusive of all such contingencies.

|                                                                                   |                                               |                    |
|-----------------------------------------------------------------------------------|-----------------------------------------------|--------------------|
|  | <b>SPECIFICATION FOR<br/>MIXED BED SYSTEM</b> | SPEC. No.:ROS 6154 |
|                                                                                   |                                               | REV: 00            |

- 3.0 The Contractor shall carry out the work in accordance with instructions/ drawings/ specification/ standard practices supplied / approved by BHEL from time to time.
- 4.0 Modification / Rectification / repair / replacement of defective components if any shall be under bidder's scope within specified time without any commercial implication to BHEL.
- 5.0 Bidder to submit the erection schedule along with stage check data sheets. Each and every stage the bidder to get clearance from the BHEL Engineer / Customer Engineer.
- 6.0 Bidder to establish the site co-ordination for identification of materials, withdrawal of material from Site BHEL stores, taking delivery, co-ordination for the movement from store to erection work stage clearance for erection & commissioning.
- 7.0 All the equipments and materials would be issued only at BHEL stores and it shall be the responsibility of the contractor to take delivery from BHEL stores and transport the same to site
- 8.0 Bidder has to keep all equipments/materials under their safe custody till the completion of erection, commissioning, trial run and handing over of the System to BHEL. Bidder should ensure deployment of adequate security personal. Necessary security arrangement around the clock is under the scope of the bidder. If any theft, pilferage or any damages are to be replaced by the bidder at their expenses (without financial implication to BHEL).
- 9.0 Necessary clearance for stage check, hydraulic test, leak check from the customer engineer & pre – commissioning tests shall be carried out by the bidder.
- 10.0 Commissioning and putting into satisfactory operation of all the equipment at site including successful completion of trial run, PG Test and handing over of the system to the end user are the responsibility of the bidder.
- 11.0 Bidder shall arrange to carryout the repair paint and Finish coat (final coat) of painting of DFT as per the spec. for all of the equipment before hand over of the system to BHEL/Customer. This is required to cover up the possible damage for the external surface of all equipment during erection/handling.
- 12.0 O& M for 3 months after PG Test (Required man power, normal consumables, tools and tackles, instruments, etc., will be under the scope of the vendor. However, necessary chemicals as per the requirement details furnished by the vendor in their bid will be provided by BHEL, free of charge).

|                                                                                   |                                               |                    |
|-----------------------------------------------------------------------------------|-----------------------------------------------|--------------------|
|  | <b>SPECIFICATION FOR<br/>MIXED BED SYSTEM</b> | SPEC. No.:ROS 6154 |
|                                                                                   |                                               | REV: 00            |

#### **14.0 EXCLUSIONS**

The following are excluded from the scope of supplier and will be arranged by BHEL

- 14.1 All civil works pertaining to DM Plant are excluded from the scope of the bidder.
- 14.2 Service water at one point near RO-DM Plant will be provided by BHEL on free of charge. Subsequent piping within and outside the plant are under the scope of the bidder.
- 14.3 Electricity (3 phase) will be available to the bidder at one point near RO-DM Plant on free of charge for erection purpose.
- 14.4 Service / instrument air will be made available at one point to the bidder on free of charge within the plant boundary. Subsequent piping within and outside the plant are under the scope of the bidder.
- 14.5 Chemicals for commissioning and trial operation of the plant will be supplied by BHEL.
- 14.6 Storage of shipped items / container at BHEL store as of received condition will be taken care by BHEL.
- 15.0 Specification, Standards & Codes:

All equipment shall be designed, tested and supplied as per the specification, relevant national / international standards & statutory codes.

#### 16.0 Name plates, labels and directional marks:

Each equipment shall be provided with nameplate details designating the tag no., service of the item etc. Necessary directional arrow marks shall be provided. Equipment name shall be painted legibly with minimum 150mm size for the vessels.

#### 17.0 Tools and Tackles:

All the Tools & tackles required for the complete erection of components shall be arranged by the contractor at his cost. The bidder shall have & own a complete set of special tools and tackles required erection, assembly, disassembly, maintenance and testing. The bidder shall also supply any special tools and tackles that may be required additionally during commissioning. All tools & tackles shall be reputed make with validity test certificates. One set of operation

|                                                                                   |                                               |                    |
|-----------------------------------------------------------------------------------|-----------------------------------------------|--------------------|
|  | <b>SPECIFICATION FOR<br/>MIXED BED SYSTEM</b> | SPEC. No.:ROS 6154 |
|                                                                                   |                                               | REV: 00            |

& maintenance tools for O&M for the system has to be supplied during the erection & commissioning and it will be retained by BHEL.

#### 18.0 Commissioning Spares:

The bidder shall supply all consumables like lubricating oil, Teflon tape, m-seal, cotton waste, tissue paper roll, sampling bottles, mugs, buckets etc required for commissioning the equipment shall be in bidder's scope.

The bidder shall consider sufficient quantity of the commissioning spares so that the commissioning of the system will not be delayed. The bidder shall also supply any spare components that may be required additionally during commissioning. These commissioning spares shall be included in the basic scope of supply.

#### 19.0 Inspection & Testing:

All the stage checks & materials for erection shall be offered as per the Quality plan wherever applicable to BHEL / Customer for inspection. During erection, the internal inspection reports shall be submitted to BHEL / customer for information.

#### 20.0 Additional requirements

20.1 After completion of all erection and commissioning works, the left out items shall be handed over to BHEL site stores.

20.2 During commissioning at site some smaller equipment may get added or Logics may have to be changed. The bidder shall carryout these changes at site without any commercial implications to BHEL.

#### 21.0 GENERAL INSTRUCTIONS TO THE BIDDER

21.1 Bidder shall quote for complete work specified in the document. Incomplete quotations for the part of the work will not be considered even if the quoted rates/price is lower.

21.2 Bidder shall contact BHEL and obtain additional details/data if any required to submit proper quotation.

21.3 The Bidder shall include all necessary commissioning spares in his basic scope of supply.

21.4 Adequate lighting facilities such as low volt hand lamps shall be arranged by the contractor at the site of construction etc. at his cost.

|                                                                                   |                                               |                    |
|-----------------------------------------------------------------------------------|-----------------------------------------------|--------------------|
|  | <b>SPECIFICATION FOR<br/>MIXED BED SYSTEM</b> | SPEC. No.:ROS 6154 |
|                                                                                   |                                               | REV: 00            |

- 21.5 All the lifting tackles including wire ropes, slings, shackles and electrically operated equipment shall be got test certificate & statutory authority approved before they are actually put on use. Test certificates & statutory authority approved certificate should be submitted to BHEL before their usage.
- 21.6 All equipment so used by contractor shall be of proven quality and safe in operation as approved by BHEL site Engineers from time to time.
- 21.7 At periodic / intervals of work, complete and detailed account of the equipment so for erected shall be submitted to the BHEL Engineer.
- 21.8 All equipments shall be handled very carefully to prevent any damage and loss. No bare wire ropes, slings etc., shall be used for unloading and / or handling for equipments. The equipments from the storage yard shall be moved to the actual site of erection / location at the appropriate time as per the direction of BHEL Engineer so as to avoid damage for such equipments at site.
- 21.9 The work covered under this scope of work is of highly sophisticated nature requiring best quality / precision workmanship engineering and construction management. He should also ensure successful and timely commercial operation of equipment installed. The contractor must have adequate quantity of precision tools, construction aids in possession. Contractor must also have adequate trained qualified and experienced supervisory staff and skilled personnel.
- 21.10 All the necessary certificates & licenses and statutory clearance required to carry out his scope of work are to be arranged by the contractor then and there at no extra cost.
- 21.11 When the work is temporarily suspended he shall protect all construction materials equipments and facilities from causing damage to existing property interfering with the operations of the station when it goes into services. The contractor shall comply with all applicable provisions of the safety regulations clean – up programme and other precautionary measures which the BHEL has in effect at the site .
- 21.12 It will be the responsibility of the contractor to ensure the safe lifting of the equipment taking due precautions to avoid any accidents and damage to other equipments and personnel.
- All piping shall be adequately supported and protected to prevent damage during handling and erection.
- 21.13 Sometimes it may become necessary for the contractor to handle certain un-required components in order to take out the required materials. The

|                                                                                   |                                               |                    |
|-----------------------------------------------------------------------------------|-----------------------------------------------|--------------------|
|  | <b>SPECIFICATION FOR<br/>MIXED BED SYSTEM</b> | SPEC. No.:ROS 6154 |
|                                                                                   |                                               | REV: 00            |

contractor has to take this contingency also into account. No extra payment is payable for such contingencies.

21.14 Due to atmospheric conditions erected materials are likely to get rusted more frequently. It is the responsibility of the contractor to preserve the erection materials drawn from stores for erection till these are commissioned and handed over to customer. The required paint, thinner all other consumables like painting brush, emery paper, cotton waste, cloth etc., have to be arranged by the contractor at his cost. The quoted rates shall be inclusive of above work. The contractor should ensure that the materials are not rusted on any account till they are handed over to customer.

**22.0 SITE CLEANLINESS AND SAFETY REQUIRMENTS:**

22.1 Contractor shall strictly follow all safety regulations / conditions as per general conditions of contract.

22.2 Providing of safety equipments like Helmet, safety goggle, hand glows etc. under the scope of bidder. Non – conformity of safety rules and safety appliances will be viewed seriously and the BHEL has right to impose fines on the contractor as under.

22.3 Contractors shall ensure that the quality is maintained in all the works connected with this contract at all stages of the requirement of BHEL.

22.4 Contractor shall ensure that all Inspection, Measuring and Testing equipment that are used, whether owned by the contractor or used on loan, are calibrated by the authorized agencies and the valid calibration certificate will be available with them for verification by BHEL. A list of such instruments possessed by contractor at site with its calibration status is to be submitted to BHEL Engineer for control.

22.5 Contractors shall arrange for the inspection of the works at various stages as required by BHEL. Immediate corrective action shall be taken by the contractor for the non-conformances if any, observed and pointed out by BHEL.

23.0 All payments due to the contractor shall be made only through “e-Payment” . The Bidder has to furnish details of his Bank account as certified by the concerned Banker in the format attached to enable e-payment.

Applicable payment shall be made after the certification of completion by the site BHEL Engineer.

|                                                                                   |                                               |                    |
|-----------------------------------------------------------------------------------|-----------------------------------------------|--------------------|
|  | <b>SPECIFICATION FOR<br/>MIXED BED SYSTEM</b> | SPEC. No.:ROS 6154 |
|                                                                                   |                                               | REV: 00            |

#### 24.0 PROVIDENT FUND & MINIMUM WAGES

24.1 The contractor is required to extend the benefit of provident fund to the labour employed by them in connection with this contract as per the Employees Provident Fund Act 1952. For due implementation of the same, the bidder is hereby required to get themselves registered with the Provident Fund authorities for the purpose of reconciliation of PF dues and furnish us the code number allotted to them by the Provident Fund authorities within one month from the date of issue of this letter of intent. In case any exemption from such remittance, an attested copy of authority for such exemption is to be furnished. Please note that in the event of failure to comply with the provisions of said Act, if recoveries there fore are enforced from payments due to BHEL by the customer or paid to statutory authorities by BHEL, such amount will be recovered from payments due to the contractor. Success full bidder before execution of work has to submit PF Regn. No. Labour License No. & Workmen Insurance Policy No.

24.2 The contractor shall ensure the payment of minimum labour wages to the workmen under him as per the rules applicable from time to time in the state.

#### 25.0 OTHER STATUATORY REQUIREMENTS:

25.1 The contractor shall submit a copy of labour licence obtained from the licencing Officer (Form VI) u/r 25 read with u/s 12 of contract labour ( R&A) Act 1970 & rules and valid WC Insurance copy or ESI Code ( if applicable) and PF code no along with the bill.

25.2 The contractor shall submit bills along with the copies of monthly wages (of the preceding month) u/r 78 (1) (a) (1) of contract labour rules, copies of monthly return of PF contribution with remittance challans under EPF Act 1952 and copy of renewed WC insurance policy or copies of monthly return of ESI contribution with challans under ESI Act 1948 (if applicable) in respect of the workmen engaged by them.

25.3 The contractor should ensure compliance of Sec 21 of Contract Labour (R&A) act 1970 regarding responsibility of payment of wages. In case of “Non compliance of sec21 or non-payment of wages” to the workmen before the expiry of wage period by the contractor, BHEL will reserve its right to pay the workmen under the orders of appropriate authority at the risk and cost of the contractor.

#### 26.0 TIME OF COMPLETION

26.1 The time schedule as prescribed in the contract is the essence of the contract. The time for completion shall always be reckoned from the date of commencement of work as certified by the BHEL Engineers.

|                                                                                   |                                               |                    |
|-----------------------------------------------------------------------------------|-----------------------------------------------|--------------------|
|  | <b>SPECIFICATION FOR<br/>MIXED BED SYSTEM</b> | SPEC. No.:ROS 6154 |
|                                                                                   |                                               | REV: 00            |

26.2 The entire work shall be completed by the contractor with in the time schedule or within the such extended time as may be allowed under relevant clause.

#### 27.0 ENGAGEMENT OF LABOUR

27.1 The contractor will be directly responsible for provision of health and sanitary arrangements more particularly described in contract labour (regulations & Abolition) Act, safety precautions etc., as may be required for safe and satisfactory execution of the contract.

27.2 The contractor shall be responsible for proper accommodation including adequate medical facilities & transportation to the work spot and back for the personnel employed by him.

#### 28.0 COMPLIANCES WITH LABOUR LAWS & RULES

28.1 The contractor shall comply with all state and central Laws, statutory rules, regulation etc., relating to labour in respect of following acts and also as amended by the Government during the tenure of the contract and having in force or jurisdiction at site.

- a. Payment of wages act, 1936
- b. Minimum wages act, 1948
- c. Workmen's Compensation act, 1923
- d. Industrial dispute act, 1947
- e. Employees Provident fund scheme, 1952
- f. Payment of Bonus act, 1965
- g. Payment of Gratuity act, 1972
- h. Contract Labour ( Regulation & Abollition) Act, 1970

#### 29.1 TAXES & DUTIES:

The contractor shall pay all taxes, VT, licence fee, deposits, duties, royalty, commissions or other charges, other than such taxes specifically mentioned in the special conditions of contract, which may be leviable on account of any of his operations in executing the contract. In case BHEL is forced to pay any of such taxes, BHEL shall have the right to recover the same from the contractor either from his bills or other wise as deemed fit.





**SPECIFICATION FOR MB SYSTEM**  
Electrical, Control & Instrumentation

**SPEC. NO.:** ROS 4140  
**REV. NO:** 00

**BHARAT HEAVY ELECTRICALS LIMITED,**  
RANIPET- 632 406.

**TECHNICAL SPECIFICATION**  
**FOR**  
**MIXED BED SYSTEM**

**ELECTRICALS, CONTROL & INSTRUMENTATION PORTION**

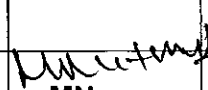
|        |          |                                                                                        |                                                                                         |                                                                                         |             |
|--------|----------|----------------------------------------------------------------------------------------|-----------------------------------------------------------------------------------------|-----------------------------------------------------------------------------------------|-------------|
|        |          |                                                                                        |                                                                                         |                                                                                         |             |
|        |          |                                                                                        |                                                                                         |                                                                                         |             |
|        |          |                                                                                        |                                                                                         |                                                                                         |             |
| 00     | 18.06.16 | AT  | VNS  | MN  | Fresh issue |
| Rev.No | Date     | Prepared                                                                               | Checked                                                                                 | Approved                                                                                | Remarks     |



## **INDEX**

| <b>SI No</b> | <b>DESCRIPTION</b>                                                                  | <b>PAGE NO</b> |
|--------------|-------------------------------------------------------------------------------------|----------------|
| 1            | GENERAL SPECIFICATION FOR E, C & I                                                  | 3              |
| 2            | E, C & I SCOPE OF WORK                                                              | 7              |
| 3            | E, C & I SCOPE OF SUPPLY                                                            | 8              |
| 4            | E, C & I SCOPE OF WORK BETWEEN BHEL & BIDDER                                        | 9              |
| 5            | LIST OF DRAWINGS / DOCUMENTS TO BE SUBMITTED ALONG WITH OFFER                       | 11             |
| 6            | LIST OF DRAWINGS / DOCUMENTS TO BE SUBMITTED AFTER ORDERING                         | 11             |
| 7            | E, C & I SPECIFICATION                                                              | 13             |
|              | 7.1 SPECIFICATION FOR LT MOTORS                                                     | 13             |
|              | 7.2 SPECIFICATION FOR INSTRUMENTATION CABLES                                        | 22             |
|              | 7.3 SPECIFICATION FOR FIELD MOUNTED JUNCTION BOXES & SOLENOID VALVE ENCLOSURE BOXES | 28             |
|              | 7.4 MEASURING INSTRUMENTS                                                           | 32             |
|              | 7.5 ACTUATORS & ACCESSORIES                                                         | 45             |
| 14           | IMPULSE PIPING, TUBING, FITTINGS, VALVES & VALVE MANIFOLDS                          | 47             |
| 15           | BILL OF QUANTITY OF E, C & I ITEMS                                                  | 50             |
| 15           | MANDATORY & COMMISSIONING SPARES                                                    | 52             |
|              | <b>ANNEXURE -1 INSTRUMENTS SCHEDULE</b>                                             |                |



**1.0 GENERAL SPECIFICATION FOR ELECTRICAL, CONTROLS & INSTRUMENTATION:**

- 1) ELECTRICAL, CONTROL & INSTRUMENTATION (E,C&I) scope of work by System bidder, scope of work between BHEL & BIDDER, Scope of supply for the system between BHEL and Bidder shall be as per this specification.
- 2) The bidder shall provide all necessary inputs to enable the Customer (BHEL) to design & procure the LT MCC, for the system.
- 3) All E,C&I equipment shall be suitable for the power supplies, fault levels and other climatic conditions indicated in "Project Information" mentioned elsewhere in this enquiry
- 4) The system bidder shall provide necessary Electrical, Control & Instrumentation equipments, Pneumatic Operated Valves (POVs), Control Valve etc. in this plant to facilitate auto operation.
- 5) The system bidder should furnish a "Write up on Control Description" explaining the controls, interlocks etc., for the auto operation of the system for information/review. Necessary Sequence Flow Charts, Logic Diagram etc., have to be furnished during detailed engineering to facilitate implementation of the system controls & interlocks in the PLC/DCS system.
- 6) Based on the inputs, the PLC/DCS Vendor will prepare the engineering software in the form of ladder diagrams for the system. The system bidder shall review and approve the ladder diagram for implementation. Once the system requirements are implemented in the PLC/DCS system after bidder's review & approval, the responsibility for proper functioning of the entire system in Auto & Manual mode shall rest with the bidder.
- 7) All field initiating devices like Pressure / Temperature / Flow / Level switches shall have the terminal block inside the switch enclosure to which external cables shall be wired. The terminals shall be suitable for 2.5 sq mm copper stranded conductors. Necessary plug in socket shall also be provided for electrical connection. The terminals of the field initiating devices shall be wired to junction boxes by cables with necessary cable trays & supports by bidder.
- 8) Junction Boxes being supplied by bidder shall comply with junction box requirements given in detailed elsewhere in this specification.
- 9) Analytical instruments for pH / ORP / Conductivity / Silica / Turbidity etc. shall consist of sensor & microprocessor based analyser which shall be located in the field. Only 4 - 20mA Single / Dual output signals from the analysers shall be brought to the PLC/DCS system where these parameters will be displayed on the PC screens using HMI software. Necessary calibration solutions / buffer powders / reagents etc. required for calibration & commissioning of analytical instruments shall be included by the bidder in his scope. The offer



should include rates for such calibration solution / buffer powder / reagents and the periodicity and quantity requirement.

- 10) To facilitate Auto operation of the system, valve operation shall be pneumatically operated. Accordingly bidder to indicate the Instrument air requirement taking into consideration the maximum number of pneumatic valves that can operate simultaneously at any point of time.
- 11) Tanks shall be provided with float operated level indicators, level gauges, level transmitters and level switches, as required, with complete assembly. Suitable flanged pads for level switch mounting shall also be provided. The level indicator can be top or side mounted as the case may be.
- 12) All drive motors for the plant shall be supplied as per specification and Motor Data sheet enclosed. The complete data for all motors shall be furnished in the Data sheet format enclosed to motor specification, during detailed engineering.
- 13) Cable glands shall be of tinned brass (double compression type) conforming to BS 6121. Cable lugs shall be of heavy duty, crimping type, tinned copper / Aluminium conforming to latest IS.
- 14) Make of various equipments / items in the scope of bidder shall be as per Vendor list enclosed with the enquiry. The bidder must indicate make of various equipments clearly in the offer. The words equivalent / reputed make are not acceptable.
- 15) Bidder shall furnish Electrical Power Consumption for various drives in the format enclosed, along with the offer to enable the customer to design the MCC for feeding the System loads. Based on this input, starters & controls will be provided by BHEL in the UF-RO-MB Plant LT MCC. Once the system requirements are implemented in the LT MCC system, the responsibility for proper functioning of the entire system in Auto & Manual mode shall rest with the bidder.
- 16) Bidder shall furnish schedule of Analytical Instrument Power, control & screened cables, Indicating Quantity of cables required, within 2(two) weeks after award of contract. However, bidder shall furnish tentative quantity of power, control & screened control cables with the offer also.
- 17) Any equipment, fitting and instrument though not specifically mentioned in the specification, PID and BOQ, but considered essential, necessary for the efficient and safe operation of the system shall be included in this supply by the bidder. All instruments shall be calibrated in metric units.
- 18) The detailed specification of various electrical / control equipments and supply system are given in the respective sections of this specification.
- 19) The instruments offered shall be of reputed make and shall have accuracy and



tolerances suitable for the purpose. Complete bill of material for control & instrumentation indicating make, type, range, quantity and location, number of signalling contacts, their rating, shall be provided by the bidder and any item of equipment instrument even though not included in bill of material but required as per scheme or otherwise for the completion and efficient functioning of the system shall be deemed to be included in the bill of material at no extra cost. The bidder shall provide detailed schematics for the controls and protections along with flow diagram clearly indicating all local control panel instruments. The instruments shall be of approved make as per the approval of Customer.

20) The instruments offered shall be complete with all accessories like isolation valves, automatic temperature compensation, monitoring accessories etc.. All instruments shall have a degree of protection as given in detailed technical specification.

21) Instruments / relay contacts shall conform to the relevant C&I sections of this Specification and shall be adequately rated to suit interlock / alarm circuitry requirements.

22) All auto valves shall be pneumatic operated type. Limit switches shall be provided on all the auto valves. Facility for adjusting speed of opening / closing of the valve shall be provided for each valve to prevent system upsets by quick opening / closing. Bidder shall furnish complete details of pneumatic actuator along with the offer.

23) All instruments shall be subjected to Routine & Type test as per relevant applicable latest standards. If Type tests are performed already on identical model, valid type test certificates are acceptable. Necessary Routine & Type test certificates shall be furnished by the bidder for all instruments.

24) We have enclosed a set of typical drawings for the frame works (for installation of instruments). Bidder may choose GI steel pipes for the fabrication of the frame instead of angles & channels wherever required. **Necessary SS fasteners and U Clamps are to be provided by the bidder for fixing the instruments.**

25) Bidder shall submit the detailed installation drawing for each instrument, showing the various components such as connector, SS tubing, valves, 2 / 3 / 5 valve manifolds etc. for the approval of BHEL. This is to ensure proper erection at site.

26). Junction Boxes / Field Termination Cabinets shall be provided for

- (a) Termination of all sensors and transmitters located area wise
- (b) Termination of transmitters to JB which is mounted on the transmitter racks.
- (c) Termination of both the contacts of switches and duplex elements of Temperature measurement.

The arrangement of terminals in the field junction boxes and the system cabinets in the control room shall match 1:1 to avoid any field marshalling issues.



27) INSTRUMENTATION & CONTROL CABLES:

These shall be supplied to:

Connect field instruments to Field Junction Boxes/ Field Termination Cabinets.

Connect limit switches, torque switches and position transmitters to Field Junction Boxes / Solenoid valve Boxes.

28) Pneumatic Operated Valve / Control Valve :

Pneumatic Actuators shall be used for operating actuated valves, wherever required. All pneumatic actuators included in the scope of bidder for ON/OFF and regulating services shall be complete with all accessories including the following:

Air Filters Regulators shall be provided in the following:

Air supply line to valve positioners

Air supply line to Electro pneumatic converters

Air supply line to each Solenoid Valve Box

29) Additional requirements

- a) All mounting accessories for various instruments shall be supplied as a part of basic scope of this package.
- b) Erection hardware like root valves, impulse lines, 2 / 3 / 5 valve Manifolds shall also be supplied as a part of basic scope of this package.
- c) Electrical equipments and instruments shall be provided with suitable earthing terminals as per relevant IS standard.
- d) Instrument air will be made available at one point. Further distribution shall be taken care of by System bidder.
- e) KKS tag numbering philosophy would be uniform for the entire plant. There would be a single, unique tag for a given equipment / signal.
- f) After completion of all erection and commissioning works, the left out items/ spares / tools & tackles / calibration instruments etc. shall be handed over to BHEL site office.

30) The following drawings shall be referred.

- |                               |                  |
|-------------------------------|------------------|
| a) PID drawing:               | - 1-WT-220-00711 |
| c) Instruments Schedule       | - ANNEXURE 1     |
| d) Installation Instructions  | - 4-WT-310-00017 |
| e) Instruments Mounting frame | - 3-WT-310-00012 |
| Arrangement (Typical)         | To               |
|                               | 3-WT-310-00025   |
| f) Instrument Hook up Diagram | - 3-WT-310-00026 |
|                               | To               |
|                               | 3-WT-310-00035   |



## **2. ELECTRICAL AND C&I SCOPE OF WORK**

| <b>SL. NO</b> | <b>ELECTRICAL, C&amp;I SYSTEM ACTIVITY</b>                                                                                                                                                                                                                                                                                         |
|---------------|------------------------------------------------------------------------------------------------------------------------------------------------------------------------------------------------------------------------------------------------------------------------------------------------------------------------------------|
| 1             | Manufacture / procurement, testing at manufacturer's works, packing delivery of instruments, Instrument cables, Cable Trays & Junction Box to site                                                                                                                                                                                 |
| 2             | Supply, fabrication of supports for junction box, panels, instruments, Erection & Commissioning of instruments, Junction Boxes (JB's) & Solenoid Valve enclosure Boxes(SVEB), laying & termination of Cables, erection of Cable Trays (from Equipment to JB) , Pneumatic Operated Valves (POV's), Control Valve (CV), SVEB at site |
| 3             | Laying & termination of cables between JB & Equipments, Laying & termination of copper tube thro' Air filter regulator for Pneumatic Operated Valves (POV's / SVEB), SS impulse tube for Instruments in GI perforated trays with supporting structure etc. at site                                                                 |
| 4             | Calibration of all instruments at site with standard calibration solutions & standard instruments                                                                                                                                                                                                                                  |
| 5             | Necessary tools required for erection & commissioning of instrumentation system                                                                                                                                                                                                                                                    |
| 6             | Carrying out pre commissioning Checks & test at site                                                                                                                                                                                                                                                                               |
| 7             | Commissioning and putting into satisfactory operation of all instruments at site including successful of trial operation and handing over the system to end user (Customer)                                                                                                                                                        |
| 8             | Providing training to BHEL & End user (BHEL Customer) at site                                                                                                                                                                                                                                                                      |
| 9             | Furnishing the Valve Operating sequence Chart / Control philosophy / Logic Diagram for the system                                                                                                                                                                                                                                  |
| 10            | Furnishing all the drawings, data sheets and documents as per this specification                                                                                                                                                                                                                                                   |
| 11            | Extending support by furnishing the required drawings/documents for obtaining approvals from customer for the specification, makes, model numbers of the instruments, GA drawing, if required.                                                                                                                                     |
| 12.           | Preparation of Instrument hook up & installation drawings, Cable schedule and Cable Interconnection diagrams                                                                                                                                                                                                                       |
| 13            | Supply of all applicable drawings as Soft copies in CD.                                                                                                                                                                                                                                                                            |



### **3. ELECTRICAL AND C&I SCOPE OF SUPPLY**

| <b>SL. NO</b> | <b>ELECTRICAL, C&amp;I SYSTEM</b>                                                                                                                                                                                                                             |
|---------------|---------------------------------------------------------------------------------------------------------------------------------------------------------------------------------------------------------------------------------------------------------------|
| 1             | Supply of Instruments as per enclosed specification / PID / E,C&I Bill Of Quantity (BOQ).                                                                                                                                                                     |
| 2             | Supply of required erection materials (Mounting skid) for mounting the instruments, Junction Boxes, Cables, Perforated Cable trays, Steel support material & Accessories (From Equipment to Junction Box)                                                     |
| 3             | Supply of required Digital & Analog signal cables ( 2 /4/ 6 / 8 /12 / 24 pair) (From Equipment to Junction Box)                                                                                                                                               |
| 4             | Supply of required Digital & Analog Junction Boxes (12 / 24 / 48 way ) (From Equipment to Junction Box)                                                                                                                                                       |
| 5             | Supply of required Perforated Cable Trays to lay the Digital & Analog signal cables (From Equipment to Junction Box)                                                                                                                                          |
| 6             | Supply of required erection materials for Instruments impulse line (Root valves, 2 / 3 / 5 Way manifold for instruments, Drain valves, 1/2" SS316 SS Tube, SS Fittings, Perforated trays for impulse tube, steel supporting structure etc)                    |
| 7             | Supply of required erection materials for instrument Air line from Solenoid valve enclosure box to POV's / SVEB ( 1/4" OD PVC insulated copper tube, Brass Fittings, Air filter regulator, Perforated trays for impulse tube, steel supporting materials etc) |
| 8             | Supply of Instrument air line header (GI Rigid pipe, bends, tees, isolation / Drain valves etc.) for distribution from BHEL Supplied terminal point at one end.                                                                                               |
| 9             | Supply of required Solenoid valve enclosure Box (SVEB) for grouping of Pneumatic Operated Valves and supply of solenoid valve for individual POV                                                                                                              |
| 10            | Supply of Commissioning & mandatory spares as per Clause no-10                                                                                                                                                                                                |



**4. ELECTRICAL AND C&I SCOPE OF WORK BETWEEN BHEL & BIDDER**

| SL. NO | ELECTRICAL SYSTEM                                                                                                           | ACTIVITY                           | AGENCY                     |
|--------|-----------------------------------------------------------------------------------------------------------------------------|------------------------------------|----------------------------|
| 1.     | 415V MCC PANEL                                                                                                              | SUPPLY<br>ERECTION                 | BHEL<br>BHEL               |
| 2.     | LT POWER & CONTROL CABLES                                                                                                   | SUPPLY<br>ERECTION                 | BHEL<br>BHEL               |
| 3      | CONTROL CABLES AND INSTRUMENTATION CABLES BEYOND JUNCTION BOX (JB), JUNCTION BOX TO PLC/DCS, PLC/DCS TO LTMCC / VFD         | SUPPLY<br>ERECTION                 | BHEL<br>BHEL               |
| 4.     | CABLING MATERIAL (CABLE TRAYS, SUPPORT MATERIAL ACCESSORIES AND CONDUITS ETC.) BEYOND JBS, JB TO DCS, DCS TO VFD/LTMCC      | SUPPLY<br>ERECTION                 | BHEL<br>BHEL               |
| 5.     | LOCAL PUSH BUTTON STATION                                                                                                   | SUPPLY<br>ERECTION                 | BHEL<br>BHEL               |
| 6.     | EQUIPMENT EARTHING                                                                                                          | SUPPLY<br>ERECTION                 | BHEL<br>BHEL               |
| 7.     | JUNCTION BOXES / SOLENOID VALVE BOXES with cable glands & lugs for incoming and outgoing cable.                             | SUPPLY<br>ERECTION<br>COMMNG CHECK | BIDDER<br>BIDDER<br>BIDDER |
| 8      | ALL CABLES BETWEEN BIDDER SUPPLIED EQUIPMENT( INSTRUMENTS, POV'S & JUNCTION BOXES / SOLENOID VALVE BOXES)                   | SUPPLY<br>ERECTION<br>COMMNG CHECK | BIDDER<br>BIDDER<br>BIDDER |
| 9      | CABLING MATERIAL (CABLE TRAYS & STEEL SUPPORT & ACCESSORIES) BETWEEN SUPPLIED EQUIPMENT & JUNCTION BOX / SOLENOID VALVE BOX | SUPPLY<br>ERECTION                 | BIDDER<br>BIDDER           |
| 10     | CABLE SCHEDULE & CABLE INTERCONNECTION DRG.                                                                                 | PREPARATION<br>ERECTION<br>VETTING | BIDDER<br>BIDDER<br>BHEL   |
| 11     | BELOW GROUND EARTHING, LIGHTING, A/C AND VENTILATION                                                                        | SUPPLY<br>ERECTION                 | BHEL<br>BHEL               |
| 12     | CONTROLS AND INSTRUMENTATION (AS PER PID ENCLOSED)                                                                          | SUPPLY<br>ERECTION<br>COMMNG.      | BIDDER<br>BIDDER<br>BIDDER |
| 13     | PLC/DCS SYSTEM                                                                                                              | SUPPLY<br>ERECTION<br>COMMNG.      | BHEL<br>BHEL<br>BHEL       |
| 14     | INSTRUMENT AIR LINE DISTRIBUTION FROM BHEL SUPPLIED TERMINAL POINT AT ONE END.                                              | SUPPLY<br>ERECTION<br>COMMNG.      | BIDDER<br>BIDDER<br>BIDDER |
| 15     | SS IMPULSE PIPING AND FITTINGS FOR INSTRUMENTS                                                                              | SUPPLY<br>ERECTION<br>COMMNG.      | BIDDER<br>BIDDER<br>BIDDER |
| 16     | CALIBRATION OF INSTRUMENTS AT                                                                                               | SUPPLY                             | BIDDER                     |



**SPECIFICATION FOR MB SYSTEM**  
**Electrical, Control & Instrumentation**

**SPEC. NO.: ROS 4140**

**REV. NO: 00**

|    | SITE WITH BUFFER SOLUTION.                  | SITE CALIBRATION            | BIDDER                     |
|----|---------------------------------------------|-----------------------------|----------------------------|
| 17 | IMPULSE PIPING AND BRASS FITTINGS FOR POV'S | SUPPLY ERECTION COMMNG.     | BIDDER<br>BIDDER<br>BIDDER |
| 18 | PANELS/JB/SVEB/INSTRUMENTS MOUNTING FRAMES  | SUPPLY FABRICATION ERECTION | BIDDER<br>BIDDER<br>BIDDER |

**NOTES:**

1. Cable gland & Lugs shall be provided by bidder for equipment supplied by bidder.
2. Cable glands shall be matching to cable sizes where cables are supplied by customer. Cable sizes shall be furnished to the bidder at detailed Engineering stage.
3. Cables other than Power, Control & Screened control cables are special cables.
4. Termination of cables at Bidder supplied equipments by bidder.
5. A separate packing list shall be provided along with the supply for the total no of cable glands & cable lugs. These items shall be packed in a separate wooden box and supplied.



**5. List of drawings / documents to be submitted along with offer.**

The bidder shall submit the following documents along with the offer:

- a) Instruments schedule indicating instruments type, location, and quantity, operating parameters, measuring range and Makes of Instruments in BHLE format.
- b) List of Electrical loads indicating KW etc.
- c) Write up on operating principle.
- d) Vendr PID,
- e) I/O lists with no of AI, AO, DI & DO

**6. List of drawings / data sheet to be submitted to be submitted within 2 weeks from the date of LOI, for the approval of the Purchaser, for all items under the scope of supply:**

- a) Detailed I/O list
- b) Instruments Schedule in BHEL format
- c) List of Electrical loads
- d) Datasheet for LT Motors in BHEL format
- e) Data Sheet for Instrument Cables
- f) Data sheets for all items / instruments in BHEL format
- g) Cable schedule and Cable Interconnection drawings ( For cables in supply and erection scope of Bidder )
- h) Maintenance instructions for trouble shooting, routine adjustments, assembly & disassembly instructions, off-line testing
- i) Test certificates for Instruments & LT motors
- j) Instruments Installation drawings for all items
- k) Control Philosophy of MB plant along with Valve Operating Sequence Chart.
- l) Instrument Hook up Drawings
- m) Installation procedure
- n) List of commissioning spare
- o) Trouble shooting and maintenance manual
- p) Dimensional drawing, mounting/installation drawings, material of construction for Junction boxes/solenoid Valve box
- q) Test & calibration certificates.



**SPECIFICATION FOR MB SYSTEM**  
Electrical, Control & Instrumentation

**SPEC. NO.: ROS 4140**  
**REV. NO: 00**

| LOAD TITLE | RATING (KW / A) |                          | No s. | UNIT (U)/STN (S) | VOLTAGE CODE* | FEEDER CODE** | EMER. LOAD (Y) | CONT.(C)/INTT.(I) | STARTING TIME >5 SEC (Y) | LOC ATION | BOA RD NO. | CABLE       |      | BLOCK CABLE DRG. No. | CONTR OL CODE | REMA RKS | LOAD No. |    |
|------------|-----------------|--------------------------|-------|------------------|---------------|---------------|----------------|-------------------|--------------------------|-----------|------------|-------------|------|----------------------|---------------|----------|----------|----|
|            | NAME PLAT E     | MAX. CONT. DEMAN D (MCR) |       |                  |               |               |                |                   |                          |           |            | SIZ E CO DE | NO S |                      |               |          |          |    |
| 1          | 2               | 3                        | 4     | 5                | 6             | 7             | 8              | 9                 | 10                       | 11        | 12         | 13          | 14   | 15                   | 16            | 17       | 18       | 19 |
|            |                 |                          |       |                  |               |               |                |                   |                          |           |            |             |      |                      |               |          |          |    |
|            |                 |                          |       |                  |               |               |                |                   |                          |           |            |             |      |                      |               |          |          |    |
|            |                 |                          |       |                  |               |               |                |                   |                          |           |            |             |      |                      |               |          |          |    |
|            |                 |                          |       |                  |               |               |                |                   |                          |           |            |             |      |                      |               |          |          |    |
|            |                 |                          |       |                  |               |               |                |                   |                          |           |            |             |      |                      |               |          |          |    |
|            |                 |                          |       |                  |               |               |                |                   |                          |           |            |             |      |                      |               |          |          |    |
|            |                 |                          |       |                  |               |               |                |                   |                          |           |            |             |      |                      |               |          |          |    |
|            |                 |                          |       |                  |               |               |                |                   |                          |           |            |             |      |                      |               |          |          |    |
|            |                 |                          |       |                  |               |               |                |                   |                          |           |            |             |      |                      |               |          |          |    |
|            |                 |                          |       |                  |               |               |                |                   |                          |           |            |             |      |                      |               |          |          |    |
|            |                 |                          |       |                  |               |               |                |                   |                          |           |            |             |      |                      |               |          |          |    |
|            |                 |                          |       |                  |               |               |                |                   |                          |           |            |             |      |                      |               |          |          |    |
|            |                 |                          |       |                  |               |               |                |                   |                          |           |            |             |      |                      |               |          |          |    |
|            |                 |                          |       |                  |               |               |                |                   |                          |           |            |             |      |                      |               |          |          |    |
|            |                 |                          |       |                  |               |               |                |                   |                          |           |            |             |      |                      |               |          |          |    |

**NOTES:**

1. COLUMN 1 TO 12 & 18 SHALL BE FILLED BY THE REQUISITIONER (ORIGINATING AGENCY); REMAINING COLUMNS ARE TO BE FILLED UP BY PEM (ELECTRICAL)

2. ABBR : \* VOLTAGE CODE (7):- (ac) A=11 KV, B=6.6 KV, C=3.3 KV, (cc): G=220 V, H=110 V, J=48 V, K=+24V, L=-24 V  
EVIAT D=415 V, E=240 V (1 PH), F=110 V IONS

: \*\* FEEDER CODE (8):- U=UNIDIRECTIONAL STARTER, B=BI-DIRECTIONAL STARTER, S=SUPPLY FEEDER, D=SUPPLY FEEDER (CONTACTER CONTROLLED)

|  |                               |                         |                                                           |                           |                |                              |  |
|--|-------------------------------|-------------------------|-----------------------------------------------------------|---------------------------|----------------|------------------------------|--|
|  | <b>LOAD DATA (ELECTRICAL)</b> | <b>JOB NO.</b>          |                                                           | <b>ORIGINATING AGENCY</b> |                | <b>PEM (ELECTRICAL)</b>      |  |
|  |                               | <b>PROJECT TITLE</b>    | 2X520 MW HNPCL VIZAG TPP                                  | <b>NAME</b>               |                | <b>DATA FILLED UP ON</b>     |  |
|  |                               | <b>SYSTEM / S</b>       | PT PLANT, DM PLANT, RW & PW CHLORINATION PLANT, ETP & STP | <b>SIGN</b>               |                | <b>DATA ENTERED ON</b>       |  |
|  |                               | <b>DEPTT. / SECTION</b> | ELECTRICAL                                                | <b>SHEET 12 OF 52</b>     | <b>REV. 00</b> | <b>DE'S SIGN. &amp; DATE</b> |  |



## **7.0 E,C&I SPECIFICATION**

### **7.1 SPECIFICATION FOR LT MOTORS**

#### **1.0 INTENT OF SPECIFICATION**

The specification covers the design, materials, constructional features, manufacture, inspection and testing at manufacturer's work, and packing of Low voltage (LV) squirrel cage induction motors along with all accessories for driving auxiliaries in thermal power station.

Motors having a voltage rating of below 1000V are referred to as low voltage (LV) motors. Maximum rating of the LV motor shall be 160 KW. Motors rated 0.20 KW and below shall be 240v,1Ph,50Hz motors.

#### **2.0 CODES AND STANDARDS**

Motors shall fully comply with latest edition, including all amendments and revision, of following codes and standards:

- IS:325 Three phase Induction motors
- IS : 900 Code of practice for installation and maintenance of induction motors
- IS: 996 Single phase small AC and universal motors
- IS: 4722 Rotating Electrical machines
- IS: 4691 Degree of Protection provided by enclosures for rotating electrical machines
- IS: 4728 Terminal marking and direction of rotation rotating electrical machines
- IS: 1231 Dimensions of three phase foot mounted induction motors
- IS: 8789 Values of performance characteristics for three phase induction motors
- IS: 13555 Guide for selection and application of 3-phase A.C. induction motors for different types of driven equipment
- IS: 2148 Flame proof enclosures for electrical appliance
- IS: 5571 Guide for selection of electrical equipment for hazardous areas
- IS: 12824 Type of duty and classes of rating assigned
- IS: 12802 Temperature rise measurement of rotating electrical machines
- IS: 12065 Permissible limits of noise level for rotating electrical machines
- IS: 12075 Mechanical vibration of rotation of electrical machines
- IS: 12615 Energy Efficient Squirrel Cage Induction Motors

In case of imported motors, motors as per IEC-34 shall also be acceptable.

#### **3.0. DESIGN REQUIREMENTS**

3.1 All LV motors will be suitable for 415V, 3 Phase, 50 Hz power supply. System fault level shall be 50kA for 1 Sec. Design Ambient Temperature of 50°C shall be considered.



3.2 All Motors shall be energy efficient type - IE2.

3.3 Motors shall be continuously rated at the design ambient temperature of 50 °C and other site conditions specified under Project Information indicated in main equipment specification. Motor ratings shall have at least a 15% margin over the continuous maximum demand of the driven equipment, under entire operating range including voltage & frequency variation specified above.

#### 3.4 Starting Requirements

1. Motor characteristics such as speed, starting torque, break away torque and starting time shall be properly co-ordinated with the requirements of driven equipment. The accelerating torque at any speed with the minimum starting voltage shall be at least 10% higher than that of the driven equipment.
2. Motors shall be capable of starting and accelerating the load with direct on line starting without exceeding acceptable winding temperature. The limiting value of voltage at rated frequency under which a motor will successfully start and accelerate to rated speed with load shall be taken to be as 80% of rated voltage during the starting period of motors.
3. The motor shall be designed for direct on line starting at full voltage. Starting current shall not exceed 6 times full load current for all auxiliaries, subject to IS tolerance.
4. The motor shall be capable of withstanding the stresses imposed if started at 110% rated voltage.
5. The following frequency of starts shall apply
  - i) Two starts in succession with the motor being initially at a temperature not exceeding the rated load temperature.
  - ii) Three equally spread starts in an hour the motor being initially at a temperature not exceeding the rated load operating temperature. (not to be repeated in the second successive hour)

#### 3.5. Running Requirements

- i) Minimum voltage required for starting the motors shall be 80% of rated voltage
- ii). Motors shall run satisfactorily at a supply voltage of 75% of rated voltage for 5 minutes with full load without injurious heating to the motor.
- iii). Motor shall not stall due to voltage dip in the system causing momentary drop in voltage up to 70% of the rated voltage for duration of 2 secs.



### 3.6. Stress During bus Transfer

1. Motors shall withstand the voltage, heavy inrush transient current, mechanical and torque stress developed due to the application of 150% of the rated voltage for at least 1 sec. caused due to vector difference between the motor residual voltage and the incoming supply voltage during occasional auto bus transfer.
2. Motor and driven equipment shafts shall be adequately sized to satisfactorily withstand transient torque under above condition.

3.7 Maximum noise level measured at distance of 1.0 metres from the outline of motor shall not exceed the values specified in IS 12065.

3.8 The max. vibration velocity or double amplitude of motors vibration as measured at motor bearings shall be within the limits specified in IS: 12075.

### 3.9 Locked rotor withstand time

1. The locked rotor withstand time under hot condition at 110% rated voltage shall be more than motor starting time at minimum permissible voltage specified below by at least 3 seconds or 15% of the accelerating time whichever is greater. Provision of speed switch shall be avoided to the extent possible.
2. Starting time mentioned above is at minimum permissible voltage of 80% rated voltage.
3. Hot thermal withstand curve shall have a margin of at least 10% over the full load current of the motor to permit relay setting utilising motor rated capacity.

### 4.0 CONSTRUCTIONAL FEATURES

1. Indoor motors shall conform to degree of protection IP: 54 as per IS: 4691. Outdoor or semi-indoor motors shall conform to degree of protection IP: 55 as per IS: 4691 and shall be of weather-proof construction. Outdoor motors shall be installed under a suitable canopy
2. Motors up to 160KW shall have Totally Enclosed Fan Cooled (TEFC) enclosures, the method of cooling conforming to IC-0141 or IC-0151 of IS: 6362. Motors rated above 160 KW shall be Closed Air Circuit Air (CACA) cooled
3. Motors shall be designed with cooling fans suitable for both directions of rotation.
4. Motors shall not be provided with any electric or pneumatic operated external fan for cooling the motors.
5. Frames shall be designed to avoid collection of moisture and all enclosures shall be provided with facility for drainage at the lowest point.
6. In case Class 'F' insulation is provided for LV motors, temperature rise shall be limited to the limits applicable to Class 'B' insulation. In case of continuous



operation at extreme voltage limits the temperature limits specified in table-1 of IS:325 shall not exceed by more than 10 deg C.

#### 4.1. Winding and insulation

All insulated winding shall be of copper.

Windings shall be impregnated to make them non hygroscopic and oil resistant.

#### 4.2. Noise and vibration

Maximum noise level measured at a distance of 1 metre from the outer surface of the motor shall not exceed 85 dB(A)

The peak amplitude of the vibration shall be within IS specified limits.

#### 4.3 Grounding

The frame of each motor shall be provided with two separate and distinct grounding pads complete with tapped hole, GI bolts and washer.

The grounding connection shall be suitable for accommodation of ground conductors as follows:

|                                                                                                                     |                 |
|---------------------------------------------------------------------------------------------------------------------|-----------------|
| LT Motors                                                                                                           |                 |
| a. Fractional HP                                                                                                    | 8 SWG GI wire   |
| b. Up to 40 KW                                                                                                      | 25 x 3 mm flat  |
| c. 41 to 70 KW                                                                                                      | 25 x 6 mm flat  |
| d. 71 KW and above                                                                                                  | 50 x 10 mm flat |
| Control Desks, Control/relay panels, LDBs, PDBs, Lighting Panels, Power receptacles, Lighting Masts, Lighting Poles | 25 x 6 mm flat  |
| LPB stations, Limit/Pressure switches, Starters, CT/PT terminal Boxes                                               | 08 SWG GI wires |
| Columns, Fence, Gates, Cable trays etc                                                                              | 25 x 6mm flat   |

The cable terminal box shall have a separate grounding pad.

#### 4.4. Terminals and Terminal Boxes

1. Terminals, terminal leads, terminal boxes, windings tails and associated equipment shall be suitable for connection to a supply system having a short circuit level, specified below

Unless otherwise stated, motors of rating 110 kW and above will be controlled by circuit breaker and below 110 kW by switch fuse-contactor. The terminal box of motors shall be designed for the fault current Short time rating for terminal boxes below 110 kW (Contactor controlled) shall be 50 KA protected by fuse for 0.25 sec

2. Unless otherwise specified or approved, phase terminal boxes of horizontal motors shall be positioned on the left hand side of the motor when viewed from the non-driving end.
3. Connections shall be such that when the supply leads R, Y & B are connected to motor terminals A B & C or U, V & W respectively, motor shall rotate in an



anticlockwise direction when viewed from the non-driving end. Where such motors require clockwise rotation, the supply leads R, Y, B will be connected to motor terminals A, C, B or V W & V respectively.

4. Permanently attached diagram and instruction plate made preferably of stainless steel shall be mounted inside terminal box cover giving the connection diagram for the desired direction of rotation and reverse rotation.
5. Motor terminals and terminal leads shall be fully insulated with no bar live parts. Adequate space shall be available inside the terminal box so that no difficulty is encountered for terminating the cable.
6. Degree of protection for terminal boxes shall be IP 55 as per IS 4691.
7. Separate terminal boxes shall be provided for space heaters.. If this is not possible in case of LV motors, the space heater terminals shall be adequately segregated from the main terminals in the main terminal box. Detachable gland plates with double compression brass glands shall be provided in terminal boxes.
8. Phase terminal boxes shall be suitable for 360 degree of rotation in steps of 90 degree for LV motors.
9. Suitable Double Compression type Cable glands and cable lugs shall be provided. Cable lugs shall be of tinned Copper, crimping type. The cable sizes will be informed during detail engineering.
10. Two separate earthing terminals suitable for connecting G.I. or MS strip grounding conductor of size suitable for solidly grounded system shall be provided on opposite sides of motor frame. Each terminal box shall have a grounding terminal.

#### 4.5. General

1. Motors provided for similar drives shall be interchangeable.
2. Suitable foundation bolts are to be supplied along with the motors.
3. Motors shall be provided with eye bolts, or other means to facilitate safe lifting if the weight is 20Kgs. and above.
4. Necessary fitments and accessories shall be provided on motors in accordance with the latest Indian Electricity rules 1956
5. All motors rated 30 kW & above shall be provided with space heaters to maintain the motor internal air temperature above the dew point. Unless otherwise specified, space heaters shall be suitable for a supply of 240V AC, single phase, 50 Hz.
6. Name plate with all particulars as per IS: 325 shall be provided



7. Unless otherwise specified, the colour of finish shall be grey to Shade No. 631 and 632 as per IS:5 for motors installed indoor and outdoor respectively. The paint shall be epoxy based and shall be suitable for withstanding specified site conditions.
8. Necessary cable glands & cable lugs for the motors shall be supplied by the bidder

#### 4.6. INSPECTION AND TESTING

1. All materials, components and equipments covered under this specification shall be procured, manufactured, as per the Approved quality plan
2. LV motors of type-tested design shall be provided. Valid type test reports not more than 5 year shall be furnished. In the absence of these, type tests shall have to be conducted by manufacturer without any commercial implication to purchaser.
3. All motors shall be subjected to routine tests as per IS: 325  
Noise level measurement and vibration test as per standards shall be conducted on all motors.

#### 4.7 DRAWINGS TO BE SUBMITTED AFTER AWARD OF CONTRACT

- a) OGA drawing showing the position of terminal boxes, earthing connections etc.
- b) Arrangement drawing of terminal boxes.
- c) Characteristic curves:
  - i) Current vs. time at rated voltage and minimum starting voltage.
  - ii) Speed vs. time at rated voltage and minimum starting voltage.
  - iii) Torque vs. speed at rated voltage and minimum voltage.  
For the motors with solid coupling the above curves i), ii), iii) to be furnished for the motors coupled with driven equipment. In case motor is coupled with mechanical equipment by fluid coupling, the above curves shall be furnished with and without coupling.
- iv) Thermal withstand curve under hot and cold conditions at rated voltage and max. permissible voltage.



#### **4.8 DATA SHEET for LT MOTORS (A.C.)**

|                                                                        |                                   |
|------------------------------------------------------------------------|-----------------------------------|
| 01. Application                                                        | :                                 |
| 02. Type                                                               | :Energy Efficient (IE2)           |
| 03. Frame size                                                         | :                                 |
| 04. Manufacturer                                                       | :                                 |
| 05. Rated output in KW                                                 | :                                 |
| 06. Duty cycle                                                         | : Continuous, S1                  |
| 07. Rated voltage, no. of phases<br>and frequency                      | : 415 V, 3 Ph, 50 Hz              |
| 08. Allowed voltage variation                                          | : $\pm 10\%$ .                    |
| 09. Allowed frequency variation                                        | : $\pm 5\%$                       |
| 10. Combined voltage and<br>Frequency variation                        | : 10 % (Absolute sum)             |
| 11. At rated Voltage and frequency                                     |                                   |
| a) Full load current (Amps)                                            | :                                 |
| b) Rated speed                                                         | :                                 |
| c) Full load efficiency                                                | :                                 |
| d) Full load power factor                                              | :                                 |
| e) Starting torque in % of FLT                                         | :                                 |
| 12. Method of starting                                                 | : DOL                             |
| 13. Degree of protection                                               | : IP 55                           |
| 14. Method of ventilation                                              | : TEFC                            |
| 15. Class of insulation                                                | : "F" (temp.rise limited to cl.B) |
| 16. Stator winding connection<br>(For continuous run) ( Delta / Star ) | :                                 |
| 17. Full load torque                                                   | :                                 |
| 18. Breakdown torque in % of FLT                                       | :                                 |



19. Pull up torque in % of FLT :
20. Locked rotor current in Amps : 600% with tolerance of 20%
21. Motor efficiency and P.F.  
at 100 % full load :
22. Locked rotor withstand time  
under hot/cold condition  
at 110 % Voltage :
23. Maximum permissible starting  
time :
24. No load current in Amps. :
25. Starting time in seconds with  
driven equipment coupled  
at 80 % voltage :
26. Actual temperature rise over  
an ambient of 50°C when motor  
is delivering rated output  
a) By thermometer method :  
b) By resistance method :
27. Number of successive starts  
with driven equipment coupled  
and motor initially at rated  
load temperature :
28. Minimum voltage required by  
the motor to bring the driven  
equipment to rated speed : To be 80% of RV.
29. Resistance per phase in ohms  
at 20 degree :
30. Direction of rotation viewed  
from driving end :
31. Make, type and size of bearing  
a) At drive end :  
b) At Non drive end :
32. Type of mounting and shaft  
Orientation :



**SPECIFICATION FOR MB SYSTEM**  
**Electrical, Control & Instrumentation**

**SPEC. NO.: ROS 4140**

**REV. NO: 00**

33. Location of terminal box :  
viewed from driving end
34. Type and number of terminals :  
brought out
35. Type and size of cable gland ( size will be given during Detail engg)
36. Cable gland entry (Top / Bottom) :
37. Tropical & fungicidal treatment :
38. GD2 of the motor :
39. Weight of the motor :



## **7.2 SPECIFICATION FOR INSTRUMENTATION CABLE**

### **1. SCOPE :**

The scope of supply of INSTRUMENT CABLE includes design, manufacture, inspection, testing, packing and delivery.

### **2. APPLICATION :**

The cable to be supplied under this specification is intended to be used for carrying the following signals in RO-DM Plant.

1. 4 – 20 mA DC analogue signals from Transmitters, Analysers, to the DCS Panel.
2. Digital Input / Digital Output signals between DCS Panel & field instruments.

### **3. APPLICABLE STANDARDS :**

3.1. The INSTRUMENT cable shall be manufactured, tested and packed as per the following standards with their latest amendment. In case of any conflict between these standards and this technical specification, the most onerous shall prevail to the extent of such difference.

IS 1554 PART 1, IS 3975, IS 3961, IS 8130, IS 5831, IS 9938, IS 10418, IS 10810, IS 8784, VDE-0815, VDE 0207 Part - 4, Part – 5, VDE 0816, VDE 0472, ANSI – MC 96.1,

3.2. Following standards are additionally applicable for FRLS cable, if FRLS cables are asked for in the Enquiry / Purchase order.

IEEE 3833, IEC 60322-1, ASTM D 2843-7, ASTM 2863-77, IEC 60754 – I, SS 4241475 Clause F3, DIN 53387

### **4. SITE ENVIRONMENT :**

- 4.1. Ambient temperature : 1 ° C to 50 ° C.
- 4.2. Relative humidity : 95% at 45 ° C.

### **5. CONSTRUCTION OF INSTRUMENT CABLE :**

The conductors shall be formed by multi-strands and insulated with PVC. Two such cores shall be twisted, and shall be taped with MELINEX and then screened with Aluminium Mylar tape. A drain wire shall be provided for individual pair screen touching the Aluminium. Then a MELINEX TAPE shall be provided on such screened pair for screen isolation. No of screened pair as per enquiry shall be laid up, collectively screened with Aluminium Mylar tape. . A drain wire shall be provided for overall screen touching the Aluminium. Such



laid – up cables shall be provided with inner sheath, armoured and outer sheath. Cables shall be suitable for continuous operation at 70 Deg.C.

### **5.1.0 CONDUCTOR :**

- 5.1.1 Material : High conductivity Annealed tinned copper of electrolytic grade
- 5.1.2 Cross section area of conductor : 0.5 sq.mm.
- 5.1.3 Construction : Multi stranded.
- 5.1.4 Number of strands & Dia : 7 / 0.3
- 5.1.5 Shape : True circular before stranding, uniform quality free from defects.

### **5.2.0 INSULATION :**

- 5.2.1 Voltage grade : 1100 V
- 5.2.2 Material : PVC Compound Type Y 13
- 5.2.3 Standard applicable : VDE 0207 Part -4
- 5.2.4 Method of application : Extrusion.
- 5.2.5 Thickness : 0.4 mm.(Nom.)
- 5.2.6 Colour : Identification of the cores and pairs shall be done with Suitable colour coding & band marking as well as by Numbering of cores / pairs as per VDE- 0815. The Details of colour coding etc., shall be as approved By the end customer during detailed engg stage.
- 5.2.6 Shade of colour : As per IS 9938.
- 5.2.7 Lay length of twin cores. : Max. 50 mm. (min. 20 twists per meter)
- 5.2.8 Sequence of twisting of twin cores : Right hand.

### **5.3.0 TAPING ON TWISTED PAIR :**

- 5.3.1 Material : MELINEX
- 5.3.2 Thickness : 0.015mm(min)
- 5.3.3 Coverage : 100%.



5.3.4 Overlap : Min 20%

**5.4.0 INDIVIDUAL PAIR SCREENING :**

5.4.1 Material : ALUMINIUM MYLAR TAPE.

5.4.2 Coverage : 100%.

5.4.3 Overlap : 25% (min).

5.4.4 Thickness : 0.055 mm (min).

**5.5.0 DRAIN WIRE FOR INDIVIDUAL SCREENING :**

5.5.1 Material : Annealed tinned copper.

5.5.2 Area of cross section : 0.51 sq mm nominal.

5.5.3 No of strands : 7.

**5.6.0 SCREEN ISOLATIONS (INDIVIDUAL PAIR SCREEN).**

5.6.1 Material : MELINEX.

5.6.2 Coverage : 100%.

5.6.3 Overlap : 20%.

5.6.4 Thickness : 0.015mm(min).

**5.7.0 OVERALLSCREEN :**

5.7.1 Material : ALUMINIUM MYLAR TAPE

5.7.2 Coverage : 100%.

5.7.3 Overlap : 25% (min).

5.7.4 Thickness : 0.055mm(min).

**5.8.0 DRAIN WIRE (OVERALL SCREEEN) :**

5.8.1 Material : Annealed tinned copper.

5.8.2 Area of cross section : 0.51 sq. mm (nominal).

5.8.3 No.of strands : 7.

**5.9.0 FILLERS (IF PROVIDED) :**



5.9.1 Material : Non – hygroscopic, fire retardant, suitable for the operating temp of cable.

**5.10.0 INNER SHEATH :**

5.10.1 Material : PVC Type YM -1 with FRLS properties

5.10.2 Method of application : Extrusion.

5.10.3 Applicable standard : VDE 0207 PART - 5

5.10.4 Minimum thickness : 0.3mm

5.10.5 Colour : Black.

**5.11.0 ARMOURING**

: Steel (galvanized) wire armouring as per IS-3975 shall be provided. Strip type of armour is not acceptable.

**5.12.0 OUTER SHEATH :**

5.12.1 Material : PVC Type YM -1 with FRLS properties

5.12.2 Method of application : Extrusion.

5.12.3 Applicable standard : VDE 0207 PART - 5

5.12.4 Minimum thickness : 1.8mm ( VDE – 0816)

5.12.5 Colour : Black

5.12.6 Tolerance on Outer Dia :  $\pm 2$ mm (max)

**5.13.0 ADDITIONAL REQUIREMENT OF OUTER SHEATH:**

5.13.1 Oxygen index : Minimum 29 when tested at 27 +/- 2 Deg.C as per ASTM D 2863-77.

5.13.2 Temperature index : Min.250°C at oxygen index 21(when tested as per ASTM D 2863-77.

5.13.3 Max . Acid gas generation : Not more than 20%. by weight when tested as per

IEC 60754 – 1

5.13.4 Light transmission : Minimum 40% when tested as per ASTM D 2843-7. (Smoke density rating shall be max.60%. This is average value and not instantaneous value).



- 5.13.5 Flammability : The finished cables shall pass the flammability test as per IEC 60322-1 and IEEE 3833.
- 5.13.6 Flame resistance : The finished cables shall pass the flame resistance requirement as per category F3 of SS4241475
- 5.13.7 Hydraulic Stability and Ultraviolet test:  
The cables shall pass Hydraulic Stability & Ultra-violet tests as per DIN 53387.
- a. If the test is already conducted on similar size and type of cables, then valid type test certificate of not older than 5 years shall be submitted.
- b. If the test is not already conducted, then the vendor has to conduct the above mentioned tests without financial and commercial implication.

**5.14.0 SPECIAL REQUIREMENT OF INSTRUMENT CABLE AT 20°C +/- 3°C:**

- 5.14.1 Characteristic impedance @1KHz : 320 (max.)
- 5.14.2 Mutual capacitance between  
Conductors at 0.8 KHz : 120 nf / km (max.).
- 5.14.3 Noise interference : Better than 60 DB.
- 5.14.4 Attenuation at 1 KHz (max) : 1.2 dB/KM.
- 5.14.5 Cross talk at 0.8 KHz : Better than 60dB
- 5.14.6 Max.Conductor resistance at 20 deg.C : 73.4 Ohm/Km (loop
- 5.14.7 Insulation Resistance : 100 M Ohm / Km (min)

**6.0. GENERAL REQUIRMENTS :**

- 6.1. The cable shall be designed to withstand all mechanical, electrical and thermal stresses under steady state and transient operation conditions.
- 6.2. A distinct inner sheath shall be provided in all twin and multi-core armoured / unarmoured cables.
- 6.3. Repaired cables and cut bit cables will not be accepted.
- 6.4. Progressive automatic on line sequential marking including manufacturer's Name, insulation material, conductor size, no. of pairs, voltage rating, type of the cable etc., progressive marking on the length of the cable at every one metre shall be provided by printing or embossing, on the outer sheath of the cable.
- 6.5. Progressive markings to read "FRLS" at every 5 metres shall be provided by printing or embossing, on the outer sheath of the cables.
- 6.6. Allowable tolerance on overall diameter of the cable shall be  $\pm 2$  mm. Variation



In diameter and the ovality at any cross section shall not be more than 1.0 mm.

6.7 The cables size (No. of cores and conductor cross section) shall be marked on the outer sheath of cable at every 5 metre by printing or embossing.

6.8 Other details as called for in IS 1554 part 1 shall also be marked on the outer sheath of the cable by printing or embossing.

6.9 The Inner and Outer sheath shall be resistant to Water, UV radiation, fungus, termite and rodent attack.

### **7.0.0 PACKING AND MARKING :**

7.1.0 The cable shall be wound on a non – returnable drum of suitable size and packed.

7.2.0 Cables shall be supplied in wooden or steel drums as per IS 10418. Wooden drums shall be of seasoned wood and shall be free from defects. Wood preservative coating shall be applied on the wood. A layer of non hygroscopic PVC / polyethylene sheet shall be provided on the axial surface of the drums on the outermost layer of the cable.

7.3.0 The ends of the cable shall be sealed by means of non – hygroscopic sealing material.

7.4.0 The information as detailed in clause 18.2 of IS 1554 (Part – I) shall be stenciled on each drum.

7.5.0 The cables shall be supplied in lengths of 1000metres.

7.6.0 Tolerance on length of cable in each drum shall be  $\pm 5\%$ .

7.7.0 However if the enquiry / order quantity is less than or equals to 1000m, the entire quantity shall be supplied in a single length.

7.8.0 After winding the cables in 1000metres in each drum the remaining quantity shall be supplied in single length.

7.9.0 Cut bit cables will not be accepted.

7.10.0 The overall quantity tolerance on each cable size will be – 2%, + 0 %.

### **8.0.0 INSPECTION AND TESTING :**

The cable shall be inspected and tested based on the following documents.

1. BHEL Technical Specification.
2. BHEL Purchase order.
3. BHEL Approved supplier's data sheet
4. BHEL Approved QP

\*\*\*\*\*



## **7.3 SPECIFICATION FOR JUNCTION BOXES & SOLENOID VALVE ENCLOSURE BOXES**

### **7.3.1 JUNCTION BOX**

#### **1.0 SCOPE OF SUPPLY:**

The scope of supply of Junction box includes manufacturing, inspection, testing, packing and delivery of junction Boxes (painted) as per this specification

#### **2.0 APPLICATION:**

The Junction boxes are used in to interconnect various field-mounted electrical equipment pertaining to RODM plant.

#### **3.0 APPLICABLE STANDARDS:**

The Junction boxes shall be manufactured and tested as per the following standards.

IS 13947 - Low voltage Switchgear and Control Gear specification.

IS 6005 - Code for Practice for Phosphate Coatings of Iron & Steel.

IS 694 - PVC insulated Cables for working voltages upto and including 1100V - specification.

#### **4.0 SITE CONDITIONS:**

- |                           |                                                                                                                                                            |
|---------------------------|------------------------------------------------------------------------------------------------------------------------------------------------------------|
| 4.1 Ambient temperature   | : 1 Deg.C to 50 Deg.C                                                                                                                                      |
| 4.2 Relative humidity     | : 100% RH                                                                                                                                                  |
| 4.3 Atmospheric condition | : Highly dusty, abrasive and polluted, conducive to fungus growth, climate is tropical. Environment is as prevalent in a coal fired thermal power station. |
| 4.4 Design temperature    | : 50 Deg.C                                                                                                                                                 |
| 4.5 Location              | : Out door                                                                                                                                                 |
- #### **5.0 GENERAL REQUIREMENTS:**
- |                                                                                        |                                                                                                                       |
|----------------------------------------------------------------------------------------|-----------------------------------------------------------------------------------------------------------------------|
| 5.1 Enclosure material                                                                 | : 3 mm Cold rolled sheet steel                                                                                        |
| 5.2 Material of Removable gland plate                                                  | : 3mm Cold rolled sheet steel                                                                                         |
| 5.3 Material of continuous hinge pin, rider clamp, rider spring, washers & rider bolt. | : SS 316                                                                                                              |
| 5.4 Pre Treatment of sheet steel                                                       | : Seven tank process as per IS 6005.                                                                                  |
| 5.5 General construction                                                               | : As per drawings forming part of this specification                                                                  |
| 5.6 Enclosure protection                                                               | : IP 55 as per IS 13947                                                                                               |
| 5.7 Terminal block type & arrangement                                                  | : ELMEX CST 2.5 or equivalent type of BHEL approved make mounted on DIN rail                                          |
| 5.8 Terminal block insulating material                                                 | : Melamine                                                                                                            |
| 5.9 Terminal block voltage grade                                                       | : 650 V (Minimum)                                                                                                     |
| 5.10 Door Gasketing                                                                    | : Neoprene gasket 6 mm thick of shore hardness 20 to 30 & density 0.4 gm/cc shall be provided on all mating surfaces. |



**SPECIFICATION FOR MB SYSTEM**  
**Electrical, Control & Instrumentation**

**SPEC. NO.: ROS 4140**

**REV. NO: 00**

- 5.11 Gland plate Gasketing : Neoprene gasket 3 mm thick of shore hardness 30 to 40 & density 0.4 gm/cc shall be provided on all mating surfaces.
- 5.12 Door Opening : Suitable for 180 ° opening.
- 5.13 Lug type : Annealed tinned solder less crimping type copper lugs shall be provided for all the terminals on both sides. Lug type shall be Dowell's CP-19 pin type (insulated) or equivalent type of BHEL approved make.
- 5.14 Cable Gland type : Nickel chromium plated Brass Double Compression type cable glands fixed on the gland plate, with dummy plugs.
- 5.15 Cable Gland size & quantity : As required
- 5.16 Number of earthing terminals : Two.
- 5.17 Size & location of earthing terminals : As required
- 5.18 Location of earthing symbol : Just above the earthing terminal. Symbol to be black lines on yellow background.
- 5.19 Rated voltage grade of junction box : 415V.
- 5.20 Mounting fasteners : 4 sets of chromium plated bolts, nuts and spring washers for mounting the JB shall be supplied.
- 5.21 All seams are to be continuously welded. There shall be no holes or sockets on top and sides.
- 5.22 Suitable DIN rails along with clamps and screws shall be provided for terminal block mounting .All terminals are to be numbered serially by suitable identification label of PVC material in white background with black numbers. Terminal blocks shall be fixed to T.B supporting DIN rail by means of suitable end plates with screws.  
Stickers have to be fixed over the cable glands to indicate the cable size.
- 5.24 Rolled lip shall be provided around three sides of door and around all sides of enclosure opening. This lip is to increase the strength and to keep dirt and liquid from dropping into the enclosure when the door is opened.
- 5.25 Name plate of 2 ply lamincoid in white colour with the inscription in black letters shall be fixed to the name plate mounting bracket on top of the junction box with plated screws.
- 5.26 The untoleranced dimensions shall be as per IS 2102.
- 6.0 MAKE OF COMPONENTS
- 6.1 Terminal block : ELMEX / CONNECTWELL / TOSHA  
CONTROLS & SWITCHGEAR /  
WAGO
- 6.2 Crimping type lug : DOWELLS / JAINSON / LOTUS



- 6.3 Cable glands : COMET / BRACCO / ANUP ENGG./  
QUALITY PRECISION/ SUNIL & Co.  
/ SIEMENS / CONTROLS &  
SWITCHGEAR / SCHNEIDER

## 7.0 PAINTING

The JB shall be painted with two coats of epoxy based Zinc Chromium primer and finally finished with two coats of epoxy paint as follows.

- Exterior & Interior : Light grey shade 631 as per IS 5.  
Finish : Semi Glossy  
Paint thickness : 50 microns.

## 8.0 PACKING

Each JB shall be fully wrapped in a polythene cover to avoid water entry and then packed separately in cardboard box. Finally all such boxes shall be packed in a wooden crate.

## 9.0 DRAWING

JB Manufacturing drawings such as General Arrangement, Mounting Arrangement, Terminal Block Details in AUTO CAD/PDF shall be submitted for approval by BHEL, (prior to start of manufacture) within 10 days from the date of purchase order.

## **7.3.2 SOLENOID VALVE ENCLOSURE BOX (SVEB)**

- 1.0 The solenoid valves shall be provided suitably as per the process requirement with corresponding SVEBs. The bidder shall locate the required no. of solenoid valves inside the enclosure box and do the tubing and wiring. The solenoid valve coil wires shall be terminated in a terminal block located inside the enclosure box. The inlet ports of the solenoid valves shall be connected to a common inlet manifold to which the air supply will be connected at site using a Air Filter Regulator (AFR). The outlet / vent connections of the solenoid valve shall also be connected to respective manifolds in each SVEB using SS 316 compression type tube fittings. The external tubing & wiring connections from the SVEB to the respective POV shall be taken care of by Bidder at site. The Terminal blocks for wiring the POV limit switches shall be located inside the respective SVEB.

### 2.0 CONSTRUCTION:

The Solenoid Valve Enclosure Box (SVEB) shall be made from Cold rolled Sheet Steel Min 3 mm. The doors shall be hinged type. The enclosure shall be suitable for IP 55. Single piece Neoprene gasket of suitable thickness shall be provided on all mating surfaces to ensure watertight seal. Enclosure box shall have 4 fixing lugs & shall be suitable for wall mounting or angle iron frame mounting.

### 3.0 Painting:

- a) Exterior: Epoxy based paint. Light grey (Shade : 631) as per IS-5.  
Paint thickness 100 microns. Finish – Semi Glossy



**SPECIFICATION FOR MB SYSTEM**  
**Electrical, Control & Instrumentation**

**SPEC. NO.: ROS 4140**

**REV. NO: 00**

- b) Interior: Epoxy based white paint. Paint thickness 50 microns.  
Finish – Glossy
- c) The following items are to be located in each SOV enclosure box and the box shall be sized to accommodate the same.
  - a) Solenoid valves – as required for POVs with min. 10% or 1 (one) no spare in each box.
  - b) Terminal Block (required No. of ways) – 1 Set with 10 % spares,
  - c) Cable Entry ; Bottom only
  - d) Double compression cable gland suitable for 2 pair x 0.5 sq. mm PVCA cable– As required for limit switch outgoing cables.
  - e) Double compression cable gland suitable for 8 pair x 0.5 sq. mm PVCA cable – As required for limit switch/Solenoid valve incoming cable.

Necessary SS316 tubing and compression fittings are to be supplied and mounted inside the enclosure Box for connection of the SOVs located inside.

The solenoid valve coils are to be wired to the terminal block by using 650V grade PVC insulated, 2.5 sq. mm stranded Copper flexible wire.

One No. ATC crimp type lug shall be provided on both sides of each TB.

Earthing bolts & nuts with lug shall be provided at opposite points on outside of the junction box with earth symbol.

Name plate with suitable inscription shall be provided for each box. The inscription details will be informed after ordering.

Incoming line size & common header : ½” SS316 Tube  
Outgoing line size (To POVs) : ¼” OD PVC Insulated Copper Tube  
Exhaust line size & Common header : ½” SS316 Tube

Terminal Block Make : ELMEX, TOSHA OR CONNECTWELL  
Cable Gland : Make: COMET, SIEMENS, SUNIL  
Cable Lugs : Make: DOWELLS, JAINSON, LOTUS  
Wires : Make: RELIANCE, RPG, NICCO, UNIVERSAL, FORT  
GLOSTER, DELTON, CCI,

## 8.0 PACKING

Each SVEB shall be fully wrapped in a polythene cover to avoid water entry and then packed separately in cardboard box. Finally all such boxes shall be packed in a wooden crate.

## 9.0 DRAWING

SVEB Manufacturing drawings such as General Arrangement, Mounting Arrangement, Terminal Block Details in AUTO CAD/PDF shall be submitted for approval by BHEL, (prior to start of manufacture) within 10 days from the date of purchase order.



## **7.4 MEASURING INSTRUMENTS**

### **1.00. GENERAL REQUIREMENTS**

- 1.01. Instruments for sensing, transmission and measuring system shall be of electronic type with signal transmission in current mode of 4-20 mA DC. For interrogation of potential free Contacts, 48V DC power supply shall be employed.
- 1.02. Tripping contact for unit as well as for equipment shall be separate from interlock and alarm contacts. Also the tripping contact for equipment and unit shall be separate. The protection system shall conform to the relevant standard as indicated in clause
- 1.03. Indicating type process switches deriving contact from pointer shall not be acceptable wherever blind switches are provided, separate gauges for local indication shall be provided to facilitate easy operation / maintenance.
- 1.04.00 The contacts of switch devices (process switches, limit switches) etc. unless higher rating is required for specific application, shall be rated continuously for 5A at 240 V AC, 50 Hz (breaking inductive circuits) and 0.25 A at 220V DC. Each switching element including the contacts from limit and torque switches of valve actuators shall be provided with two contacts. All spare contacts of the switch devices, shall be wired to the nearest junction box/ terminal box.
- 1.05. All electronic modules shall have gold plated connector fingers and further all input and output modules shall be short circuit proof. These shall also be tropicalised & components shall be of industrial grade or better.
- 1.06. All equipment/systems located in the field shall be suitable for continuous operation without loss of function, departure from specifications or damage, at the ambient temperature of 50 deg.C and relative Humidity 95%.

All electrical & electronic equipments located in hazardous areas shall be provided with explosion proof enclosures safety barriers manufactured according to internationally accepted codes NEC, BASEEFA, CENELEC, JIS, VDE, CEL, UTI etc. Applicable protection certificates (explosion proof, intrinsic safe etc.) shall be furnished for equipment to be installed in areas classified as hazardous.

Bidder must clearly bring out in his proposal the hazardous area classification for the entire plant in accordance with International codes.

- 1.07. All equipment/systems located in air conditioned areas shall also be designed and constructed to operate for short periods of plant operation when air-conditioning equipment malfunctions (without loss of function,



departure from specifications requirements or damage) at the maximum ambient temperature of 50 deg. C and relative humidity of 95%. RH.

- 1.08 Measuring instruments / equipment and subsystems offered by the bidder shall be from reputed experienced manufacturers of specified type and range of equipment, whose guaranteed and trouble free operation has been proven. Further, all instruments shall be of proven reliability, accuracy, and repeatability requiring a minimum of maintenance. They shall comply with the acceptable international standards and shall be subject to Employer's approval. All instrumentation equipment and accessories under this specification shall be furnished as per technical specifications, ranges, makes / numbers as approved by the Employer during detailed engineering.
- 1.09 Every panel-mounted instrument requiring power supply shall be provided with a pair of easily replaceable glass cartridge fuses of suitable rating. Every instrument shall be provided with a grounding terminal and shall be suitably connected to the panel grounding bus.
- 1.10 All local gauges as well as transmitters, sensors, and switches for parameters like pressure, temperature, level, flow etc. as required for the safe and efficient operation and maintenance as well as for operator and management information (including all computation) of equipment in the system under the scope of specification shall be provided. The Bidder shall furnish all Instrumentation / Control equipment & accessories under this specification as per technical specification, ranges, makes & model as approved by the Employer during detailed engineering.
- 1.11 The necessary root valves, impulse piping, drain cocks, gauge-zeroing cocks, valve manifolds and all the other accessories required for mounting/ erection of these local instruments shall be furnished, even if not specifically asked for, on as required basis. The contacts of equipment mounted instruments, sensors; switches etc. for external connection including spare contacts shall be wired out in flexible/ rigid conduits, independently to suitably located common junction boxes. The proposal shall include the necessary cables, flexible conduits, junction boxes and accessories for the above purpose.
- 1.12 **SELECTION OF RANGES FOR INSTRUMENTS**

The ranges of the instruments shall be selected based on the following Philosophy Indicated below:

For pressure measurements, the maximum operating pressure will be Within 70 to 80% of the maximum scale range. All pump suction measurements will cover the negative pressure range also.

For temperature measurement, the maximum operating temperature will be within 80 to 90% of the maximum scale range.

For pressure switches and temperature switches, the set points shall fall within



40% to 70% of the scale range selected.

For level measurement, the maximum of the range will cover the overflow point or six inches from the top of the vessel and the minimum of the range will be six inches above the bottom of the vessel. Also, the gauge glasses will be stacked with overlap to cover permissive, alarm and trip levels.

For flow measurement, the maximum range shall be fixed at about 10 to 15% above the maximum operating flow.

For electro-chemical measurements (conductivity, pH, Silica etc.), the maximum Range will be around 10 to 15% higher than the recommended alarm settings.

## **2.00 TRANSMITTERS**

### **2.01 SPECIFICATION FOR ELECTRONIC TRANSMITTER FOR PRESSURE, D.P., FLOW AND LEVEL ELECTRONIC TRANSMITTERS**

| <b>Sr. No.</b> | <b>Features</b>     | <b>Essential/Minimum Requirements</b>                                                                                                                                                                  |
|----------------|---------------------|--------------------------------------------------------------------------------------------------------------------------------------------------------------------------------------------------------|
| 1.             | Type of Transmitter | Microprocessor based 2 wire type, Hart protocol compatible.                                                                                                                                            |
| 2.             | Accuracy            | $\pm 0.1\%$ of calibrated span ( minimum)                                                                                                                                                              |
| 3.             | Output signal Range | 4-20 mA DC (Analog) along with superimposed digital signal (based on HART protocol)                                                                                                                    |
| 4.             | Turn down ratio     | 10:1 for vacuum/very low pressure applications.30:1 for other applications.                                                                                                                            |
| 5.             | Stability           | $\pm 0.1\%$ of calibrated span for six months for Ranges up to and including 70 Kg/cm <sup>2</sup> .<br>$\pm 0.25\%$ of calibrated span for six months for Ranges more than 70 Kg/cm <sup>2</sup> (g). |
| 6.             | Zero and span       | +/- 0.015% per deg.C at max span.<br>+/-0.11% per drift deg.C at min. span.                                                                                                                            |
| 7.             | Load impedance      | 500 ohm (min.)                                                                                                                                                                                         |
| 8.             | Housing             | Weather proof as per IP-55 with durable corrosion resistant coating.                                                                                                                                   |
| 9.             | Over Pressure       | 150% of max. Operating pressure                                                                                                                                                                        |



**SPECIFICATION FOR MB SYSTEM**  
**Electrical, Control & Instrumentation**

**SPEC. NO.: ROS 4140**

**REV. NO: 00**

|     |                                         |                                                                                                                                                                                                                                                                                                                                                                        |
|-----|-----------------------------------------|------------------------------------------------------------------------------------------------------------------------------------------------------------------------------------------------------------------------------------------------------------------------------------------------------------------------------------------------------------------------|
| 10. | Connection<br>(Electrical)              | Plug and socket type                                                                                                                                                                                                                                                                                                                                                   |
| 11. | Process<br>Connection                   | 1/2 inch NPT (F)                                                                                                                                                                                                                                                                                                                                                       |
| 12. | Span and Zero                           | Continuous, tamper proof, Remote as well as adjustability manual from instrument with Zero suppression and elevation facility.                                                                                                                                                                                                                                         |
| 13. | Accessories                             | -Diaphragm seal, pulsation dampeners, Siphon etc. as required by service and operating condition.<br><br>-2 valve manifold for absolute pressure Transmitters (3-valve manifold for gauge / vacuum pressure transmitters) and 5 valve manifold for DP/level/flow transmitters.<br><br>-For hazardous area, explosions proof enclosure as described in NEC article 500. |
| 14. | Diagnostics                             | Self Indicating feature                                                                                                                                                                                                                                                                                                                                                |
| 15. | Power supply                            | 24V DC $\pm$ 10%.                                                                                                                                                                                                                                                                                                                                                      |
| 16. | Adjustment /calibration/<br>maintenance | Centralised PC based system. To be calibrated by handheld HART Calibrator at site.                                                                                                                                                                                                                                                                                     |

**Notes :**

In case it becomes necessary to use a DP transmitter for pressure measurement then a 3-valve manifold should be used in place of 2-valve manifold. LVDT type is not acceptable.

Where the process fluids are corrosive, viscous, solid bearing or slurry type, diaphragm seals shall be provided. Parts below the diaphragm shall be removable for cleaning. The entire volume above the diaphragm shall be completely filled with an inert liquid suitable for the application.

**2.02. ULTRASONIC TYPE LEVEL TRANSMITTERS**

| <b>Sl. No.</b> | <b>Features</b> | <b>Essential/Minimum Requirements</b>   |
|----------------|-----------------|-----------------------------------------|
| 1.             | Type of         | Non contact Microprocessor based 2 wire |



**SPECIFICATION FOR MB SYSTEM**  
**Electrical, Control & Instrumentation**

**SPEC. NO.: ROS 4140**

**REV. NO: 00**

|     |                                     |                                                                                                                                                                                                                                                                          |
|-----|-------------------------------------|--------------------------------------------------------------------------------------------------------------------------------------------------------------------------------------------------------------------------------------------------------------------------|
|     | Transmitter                         | type, Hart protocol compatible ultrasonic transmitter.                                                                                                                                                                                                                   |
| 2.  | Output signal                       | Galvanic ally isolated 4-20 mA DC (Analog) along with superimposed range digital signal (based on HART protocol)                                                                                                                                                         |
| 3.  | Sensor Accuracy                     | ± 0.5% of calibrated span (minimum)                                                                                                                                                                                                                                      |
| 4.  | Sensor Repeatability                | 3 mm or better                                                                                                                                                                                                                                                           |
| 5.  | Power Supply                        | 24V DC +/- 10%                                                                                                                                                                                                                                                           |
| 6.  | Temperature Compensation            | In built with the transducer                                                                                                                                                                                                                                             |
| 7.  | Configuration                       | Sensor unit and Electronic unit are to be separate. It shall be possible to mount the electronic unit at a remote accessible location from the transducer. All cable and weather proof fitting to interconnect transducer to electronic unit shall be provided by Bidder |
| 8.  | Housing                             | Weather proof as per IP-55 with durable corrosion resistant coating.                                                                                                                                                                                                     |
| 9.  | Calibration                         | Through HART Communicator                                                                                                                                                                                                                                                |
| 10. | Span and Zero adjustment<br>without | Continuous, tamper proof, Remote as well as manual adjustability from instrument. It shall be possible to calibrate the instrument<br>any level in the tank/sump etc                                                                                                     |
| 11. | Sensor material                     | Corrosion resistant material to suit individual application requirement                                                                                                                                                                                                  |
| 12. | False signal tolerance              | Transmitter shall be capable of ignoring false echoes from internal tank/sumps obstructions such as pipes heating coils or agitator blades. Also transmitter shall have adjustable damping Circuitry                                                                     |
| 13. | Range                               | Range of transmitter shall be capable of covering the complete level span of tank talking care of blocking distance, frequency Attenuation due to surface, obstruction, vapours etc                                                                                      |



**SPECIFICATION FOR MB SYSTEM**  
**Electrical, Control & Instrumentation**

**SPEC. NO.: ROS 4140**

**REV. NO: 00**

|     |                            |                                                                                                                                                                                                                                                                                              |
|-----|----------------------------|----------------------------------------------------------------------------------------------------------------------------------------------------------------------------------------------------------------------------------------------------------------------------------------------|
| 14. | Display                    | Minimum 4 character display with integral keypad access protected by user code                                                                                                                                                                                                               |
| 15. | Diagnostics                | Loss of echo alarm etc                                                                                                                                                                                                                                                                       |
| 16. | Load impedance             | 500 ohms (min.)                                                                                                                                                                                                                                                                              |
| 17. | Connection<br>(Electrical) | Plug and socket type                                                                                                                                                                                                                                                                         |
| 18. | Accessories                | All weather canopy for production from direct sunlight and direct rain<br><br>All mounting hardware and accessories required for erection and commissioning mounting fittings material shall be SS 316<br><br>For hazardous areas, explosion proof enclosure as described in NEC article 500 |

### 2.03 Guided Wave Radar Type Level Transmitter

Guided wave radar type level transmitters shall be provided for level measurements of the vessel under vacuum or low pressure applications.

|                       |                                                                                                                 |
|-----------------------|-----------------------------------------------------------------------------------------------------------------|
| Type                  | Guided wave Radar                                                                                               |
| Principle             | TDR (Time domain reflectometry)                                                                                 |
| Probe Type & Material | Coaxial, SS316/316L. If required probe shall be suitable for overfill prevention.                               |
| Signal o/p            | 4-20mA with HART signal suitable for overfill prevention.                                                       |
| Display               | Integral                                                                                                        |
| Power supply          | 24 VDC                                                                                                          |
| Accuracy              | 5mm                                                                                                             |
| Electromagnetic       | shall meet EN 61326-1 (1997) and Amdt A1, compatibility class A equipment/EN 50081-2 & EN 5008 1-2 & EN 50082-2 |
| Mounting              | External cage mounting                                                                                          |

The transmitters shall be provided with IP-55 protection class with durable corrosion resistant coating.



The transmitters shall be able to provide digital signals super imposed on 4-20mA signal as per HART protocol.

If liquid is corrosive then non-contact type radar type level transmitter can be supplied.

**3.00 SPECIFICATION FOR PR. GAUGE, D.P. GAUGE, TEMP. GAUGE AND LEVEL GAUGE.**

| Sl. No | FEATURES                     | ESSENTIAL / MINIMUM REQUIREMENTS                                   |                                                                                                   |                                                                                        |
|--------|------------------------------|--------------------------------------------------------------------|---------------------------------------------------------------------------------------------------|----------------------------------------------------------------------------------------|
|        |                              | Pr. Gauge/ DP Gauge/ Draught gauges                                | Temperature Gauge                                                                                 | Level Gauge*                                                                           |
| 1      | Sensing Element and material | Bourdon for high pressure, Diaphragm/ Bellow for low Pr. of 316 SS | Mercury in steel for below 450°C and inert gas actuated for above 450°C of SS bulb and capillary. | Tempered, toughened Borosilicate gauge glass steel armoured Reflex or Transparent type |
| 2.     | Body material                | Die-cast aluminium                                                 | Die-cast aluminium                                                                                | Forged carbon steel / 304 SS                                                           |
| 3      | Dial size                    | 150mm                                                              | 150 mm                                                                                            | Tubular covering entire range                                                          |
| 4      | End connection               | 1/2 inch NPT (F)                                                   | 3/4" NPT (F)                                                                                      | Process connection as per ASME PTC and Drain / vent 15 NB                              |
| 5      | Accuracy                     | ±1% of span                                                        | ± 1% of span                                                                                      | ± 2%                                                                                   |
| 6      | Scale                        | Linear, 270° arc graduated in metric units                         | Linear, 270° arc graduated in °C                                                                  | Linear vertical                                                                        |
| 7      | Range selection              | Cover 125% of max. of scale                                        | Cover 125% of max. of scale                                                                       | Cover 125% of max. of scale                                                            |
| 8      | Over range                   | Test pr. for the assembly shall be 1.5 to the max.                 |                                                                                                   |                                                                                        |



**SPECIFICATION FOR MB SYSTEM**  
**Electrical, Control & Instrumentation**

**SPEC. NO.: ROS 4140**

**REV. NO: 00**

|    |                              |                                                                                                                  |                                     |                                                                                                                          |
|----|------------------------------|------------------------------------------------------------------------------------------------------------------|-------------------------------------|--------------------------------------------------------------------------------------------------------------------------|
|    | test                         | Design pr. at 38°C.                                                                                              |                                     |                                                                                                                          |
| 9  | Housing                      | Weather and dust proof as per IP-55                                                                              | Weather and dust proof as per IP-55 | CS/304 SS leak proof                                                                                                     |
| 10 | Zero/span adjustment         | Provided                                                                                                         | Provided                            | –                                                                                                                        |
| 11 | Identification               | Engraved with service legend or laminated phenolic name plate                                                    |                                     |                                                                                                                          |
| 12 | Accessories                  | Blow out disc, siphon, snubber, pulsation dampener, chemical seal (if required by process) gauge isolation valve | SS Thermowell                       | Gasket for all KEL-F shield for transparent type vent and drain, valves of Steel/SS as per CS/Alloy process Requirement. |
| 13 | Material of Bourdon/movement | 316 SS / 304 SS                                                                                                  |                                     | 316 SS / 304 SS                                                                                                          |

Notes:-

\* Bicolour type level gauges will be provided for application involving steam and water except for condensate and feed water services

Length of gauge glass shall not be more than 1400 mm. If the vessel is higher, multiple gauge glasses with 50 mm overlapping shall be provided.

Where the process fluids are corrosive, viscous, solid bearing or slurry type, diaphragm seals shall be provided. Parts below the diaphragm shall be removable for cleaning. The entire volume above the diaphragm shall be completely filled with an inert liquid suitable for the application.

Following vendors may be referred for pressure gauges-

1. SWITZER PNEUMATICS PVT LTD, Chennai
2. SWITZER PROCESS INSTRUMENTS PRIVATE LIMITED, Ghaziabad
3. A.N. INSTRUMENTS (P) LTD., Chennai
4. PREMIER INSTRUMENTS & CONTROLS, Coimbatore.
5. MANOMETER (INDIA) PVT LTD, Chennai
6. H.GURU INSTRUMENTS (S.I) P.LTD,
7. PYRO ELECTRIC INSTRUMENTS (GOA) PVT. LTD, Goa, Udaipur
8. WALCHANDNAGAR INDUSTRIES LIMITED, Dharwad
9. GAUGES BOURDON INDIA PVT LTD, Chennai
10. NEW SCIENTIFIC REPAIRS & TRADING CO, Kolkata
11. GOA INSTRUMENTS INDUSTRIES PVT LTD, Goa
12. BAUMER TECHNOLOGIES INDIA PVT LTD., Chennai



#### 4.00 ROTAMETERS

| Sl. No. | Features                 | Essential / minimum requirements                                          |
|---------|--------------------------|---------------------------------------------------------------------------|
| 1.      | Type                     | Variable Area metal tube                                                  |
| 2.      | Fluid media              | Water                                                                     |
| 3.      | Tube body                | SS316                                                                     |
| 4.      | Material of float        | 316 SS                                                                    |
| 5.      | Indicator                | Linear scale                                                              |
| 6.      | Accessories              | Flange, orifice in case of bypass Rota meter (for line size above 100 mm) |
| 7.      | Housing protection class | IP-55                                                                     |
| 8.      | Accuracy                 | + 2% of measured value.                                                   |
| 9.      | Repeatability            | +/- 0.5% of full scale.                                                   |
| 10.     | Flow rangeability        | Greater than 3                                                            |
| 11.     | Packing                  | Teflon                                                                    |

Vendor- EUREKA, Pune; IEPL, Hyderabad; Placka, Chennai; Trac, Hyderabad; Fluidyne Instruments PVT LTD. Mumbai.

Note- Bypass Rotameters for line sizes more than 100mm else online rotameter.

#### 5.00 PROCESS ACTUATED SWITCHES

| FEATURES | ESSENTIAL / MINIMUM REQUIREMENTS                                            |                                                                                               |                                                                        |
|----------|-----------------------------------------------------------------------------|-----------------------------------------------------------------------------------------------|------------------------------------------------------------------------|
|          | Pressure/<br>Draft<br>Switches/<br>DP<br>Switches                           | Temperature<br>switches                                                                       | Level switches                                                         |
| Sensing  | Piston actuated types Element and diaphragm or bellows for low pr. / Vacuum | Vapour pressure for high pressure filled bellow type With SS bulb and capillary (10M minimum) | Float type switches for sensing liquid medium, Condensate application. |



**SPECIFICATION FOR MB SYSTEM**  
**Electrical, Control & Instrumentation**

**SPEC. NO.: ROS 4140**

**REV. NO: 00**

|                                  |                                                                                                                          |                                               |                                       |
|----------------------------------|--------------------------------------------------------------------------------------------------------------------------|-----------------------------------------------|---------------------------------------|
| Material                         | 316 SS                                                                                                                   | Bulb 316 SS/<br>capillary 304 SS              | 316 SS                                |
| End connection                   | ½ inch NPT (F)                                                                                                           | ½ inch NPT (F)                                | Manufacturer standard                 |
| Over range proof                 | 150% of max. design pr.                                                                                                  | -                                             | 150% of max. design Pressure Pressure |
| Repeatability                    | + 0.5% of full range                                                                                                     |                                               |                                       |
| No. of contacts                  | 2 No.+2NC. SPDT snap action dry contact                                                                                  |                                               |                                       |
| Rating of contacts               | 60 V DC, 6 VA- (or more if required by DDCMIS)                                                                           |                                               |                                       |
| Elect. Connection                | Plug in socket                                                                                                           |                                               |                                       |
| Set point/ dead band adjustment  | Provided over full range                                                                                                 |                                               |                                       |
| Enclosure                        | Weather and dust proof as per IP-55                                                                                      |                                               |                                       |
| Accessories                      | Siphon, snubber, Chemical seal pulsation dampeners as required by process                                                | Thermo well of 316 SS and packing glands      | All mounting accessories              |
| Mounting                         | Suitable for enclosure/ rack mounting or                                                                                 | Suitable for rack mounting or direct mounting | -                                     |
| Power Supply (wherever Required) | 24 V DC to be arranged by Bidder except for Ash level Switches where the same shall be as per Bidder's Standard practice |                                               |                                       |

Length for level switches shall be site adjustable.  
 Where the process fluids are corrosive, viscous, solid bearing or slurry type, diaphragm seals shall be provided. Parts below the diaphragm shall be removable for cleaning. The entire volume above the diaphragm shall be completely filled with an inert liquid suitable for the application.



## 6.00 SPECIFICATION FOR FLOW ELEMENTS

### 6.01 Orifice Plate

#### Features

#### Essential/Minimum Requirements

|                                                |                                                                         |
|------------------------------------------------|-------------------------------------------------------------------------|
| Type                                           | Concentric as per ASME PTC-19.5 (Part-II), SA RP-3.2, 1960 or BS-1042   |
| Material                                       | 316 SS                                                                  |
| Thickness                                      | 3mm for main pipe diameter upto and 6mm for main pipe dia above 300 mm. |
| 300mm                                          |                                                                         |
| Material of branch pipe                        | Same as main pipe                                                       |
| Root valve type                                | Globe / Needle                                                          |
| Root valve material                            | 316 SS                                                                  |
| Root valve size                                | 1 inch                                                                  |
| Impulse pipe of same material up to root valve | Required                                                                |
| Tappings                                       | Flanged weld neck. 3 pairs. of tapping.                                 |
| Beta Ratio                                     | 0.34 to 0.7                                                             |
| Beta Ratio calculation to be submitted         | Yes                                                                     |
| Assembly drg. and flow Vs DP Curves            | Yes                                                                     |
| Accessories                                    | Root valves, flanges, Vent/drain hole (As required)                     |

Bidder shall submit certified flow calculation and differential pressure vs. flow curves for each element for Employer's approval. Sizing calculation, precise flow calculation for all the flow elements, fabrication and assembly drawings and installation drawings shall be submitted for Employer's approval. One Flow element of each type shall be calibrated in the test laboratory for validation of commutated flow calculations.

Each flow element shall have the name plate engraved on the element. This name plate shall have details of tag no, make, serial no, body material, beta ratio, line size, thickness, flow direction etc. as minimum. All these details shall also be put on the additional tag plate attached to the flow element, which shall be easily visible from outside of the insulation.

## 7.00. SPECIFICATION FOR pH ANALYSER

01. Item : pH Analyser
02. Application / Medium : To suit the system requirement.
03. Ambient Temperature : 50 Deg.C.
04. Surrounding Atmosphere : Dusty, humid & corrosive atmosphere .  
Relative humidity - 100%.



05. Design Condition : To suit the system requirement.

**06. Sensor :**

- a) Installation : Mounted on bypass line. Flow through chamber or Tee to be offered for bypass line installation.
- b) Measuring Electrode : Double junction, combined electrode housed in tough, corrosion proof body.
- c) Accessories : i) Pre-Amplifier if required  
ii) Screened junction box for electrodes.
- d) Temperature Compensation : Automatic (integral) upto 0-100 ° C.
- e) Wetted Parts : Bidder to select suitable for the medium.
- f) Sensor Connection : Suitable for threading to flow thro' chamber mounted on bypass line.
- g) Sensor to Indicator Cable Length : 10 Mtrs. (Per mtr. Rate to be offered for ordering additional length, if required).

**07. Analyser :**

- a) Type : Solid State / Microprocessor based
- b) Scale Range : 0-14 pH
- c) Mounting : Wall / Panel / Pipe mounted type
- d) Protection Class : NEMA 4X, IP 65, weather & water proof
- e) Display : Digital.
- f) Temperature Compensation : Automatic (-15 to 100 Deg. C)
- g) Calibration : Calibration with standard
- m) Features : a) Zero & span adjustable Auto zero check  
b) Manual zero and span calibration.
- n) Output : Single / Dual 4-20 mA Isolated
- o) Alarms : pH High/Low

**08. Performance:**

- a) Accuracy :  $\pm 0.02$  pH
- b) Power Supply : 240V, 50Hz, 1ph, AC
- c) Cable Termination : Terminal block to suit 2.5 sqmm wires.
- d) Stability :  $\pm 0.01$  pH / Month, non cumulative

**8.00. SPECIFICATION FOR CONDUCTIVITY ANALYSER**

01. Item : Conductivity Analyser
02. Application / Medium : Demineralised Water.
03. Ambient Temperature : 50 Deg.C.
04. Surrounding Atmosphere : Dusty, humid & corrosive atmosphere .



05. Design Condition : Relative humidity - 100%.  
: To suit the system requirement.

**06. Sensor :**

- a) Installation : Mounted on bypass line. Flow through chamber or Tee to be offered for bypass line installation.
- b) Measuring Electrode : Unbreakable electrode housed in tough, corrosion proof body.
- c) Preamplifier (if required) : Integral with the sensor.
- d) Temperature Compensation : Automatic (integral) upto 0-100 ° C.
- e) Wetted Parts : Bidder to select suitable for the medium.
- f) Sensor Connection : Suitable for threading to flow thro' chamber mounted on bypass line.
- g) Sensor to Indicator Cable Length : 10 Mtrs. (Per mtr. Rate to be offered for ordering additional length, if required).

**07. Analyser :**

- a) Type : Solid State / Microprocessor based
- b) Scale Range : To suit the system requirement.
- c) Mounting : Wall / Panel / Pipe mounted type
- d) Protection Class : IP 55, weather & water proof
- e) Display : LCD / LED with alarm status and Indications.
- f) Temperature Compensation : Automatic (0-100 Deg. C)
- g) Calibration : Calibration with standard buffer solution.
- h) Alarms : High
- i) Accessories : 2 Adjustable set points
- j) Output Signal : Single / Dual Isolated 4-20 mA DC linear signal.
- k) Enclosure : Corrosion proof plastic enclosure.
- l) Auto Calibration : To be provided.
- m) Features : Zero Check.

**08. Performance:**

- a) Accuracy % FSD :  $\pm 1$
- b) Power Supply : 240V, 50Hz, 1ph, AC
- c) Cable Termination : Terminal block to suit 2.5 sqmm wires.
- d) Stability : 0.5% of reading / month.

**9.00 Specification for density Indicator (as given below or better.)**

Type- : Inline Density indicator.

Density/Secific Gravity Range : As per process requirement

Temperature Rating : 60°C

Pressure Rating : 9 kg/cm<sup>2</sup> g for MS/ SS Wetted Parts & 3 kg/cm<sup>2</sup>g For pp lined wetted parts



|                                                             |                                                                                       |
|-------------------------------------------------------------|---------------------------------------------------------------------------------------|
| Process Connection                                          | :15NB to 25NB Flanged or Screwed<br>( Screwd Conn. not Applicable for PP lined Parts) |
| Hydrometer MOC                                              | :Glass ( Borosilicate Glass Against Request)                                          |
| Wetted Parts Moc                                            | : SS / MS / PP Lined                                                                  |
| Enclosure                                                   | : Glass Tube in Open Frame                                                            |
| Accessories :                                               |                                                                                       |
| Pocket for Thermometer ( Not Applicable for PP Lined Parts) |                                                                                       |

## **7.5 SPECIFICATION FOR PNEUMATIC ACTUATOR**

### **01 ACTUATOR:**

- a) Quantity : 01 No. for each Pneumatic Operated Valve (POV)
- b) Type : Pneumatic Diaphragm Actuator, Double / single acting (as per process requirement)
- c) Action : Air to Open & Air to Close
- d) Pressure : 5 to 8 Kg /sq. cm
- e) Air Connection : 1/4" NPT(F) copper tube.
- f) Local Position Indicator : To be provided.
- g) Hand wheel for manual operation : Required
- h) Speed adjustment for Actuator operation : To be provided to facilitate speed adjustments both during opening & closing by means of flow control valve.
- i) Action of driving equipment on air failure, power supply failure : Stay put
- j) Type of operation : I) Solenoid Valve Energised for valve to open & Solenoid Valve De-energised for valve to close  
OR  
II) Solenoid Valve De-energised for valve to open & Solenoid Valve Energised for valve to close

The above requirement shall be informed during order Execution stage for each POV. Bidder to supply accordingly.

- k) Actuator Make : As per vendor list enclosed with the enquiry.

### **02 LIMIT SWITCHES:**

- a) Quantity : One for Open & one for Close position for each POV.
- b) No. of Contacts : Two normally open & two normally closed potential free contacts in each limit switch corresponding to open & close positions of the valve.
- c) Contact Rating : 5A,240V AC , 0.5A, 220 V DC
- d) Protection : Weather proof IP 55.



- e) Cable Gland : Suitable for 2P x 0.5 sq mm PVCA cable.  
f) Limit Switch Box : Limit Switch terminals shall be brought out to a Terminal Box

### **03. Air Filter Regulator (AFR)**

Constant bleed type AFR with an accuracy of +0.1%, inlet pressure range of 5-8 kg/cm<sup>2</sup> and suitable spring ranges (AFR) for use with positioners in control valves, control damper, E/P converters and shut off valves for phosphor bronze filter element; Filtering particles above five microns.

Weather and water proof enclosure. Material of accessories will be SS.

Air filter regulators shall be provided in the :

- (a) Air supply line to valve positioners / power cylinders  
(b) Air supply line to electric to pneumatic converters.  
(c) Air supply line to pneumatic interlocked block valves.  
(d) For each instrument rack, field instruments enclosure for purging.

### **04. SOLENOID VALVE:**

- a) Quantity : 01 No. for each POV actuator.  
b) Type : Single coil solenoid valve suitable for the diaphragm actuator with needle type flow control valve to adjust valve closing / opening speed.  
c) Body : Bronze  
d) Plunger : SS316  
e) Pressure range : 5 to 8 Kg/sq. cm  
f) Duty : Continuous  
g) Coil Voltage : 24 V DC.  
h) Air Connection : 1/4" NPT(F)  
i) Protection : Weather proof IP65.  
j) Class of insulation: " F "  
k) Manual override for solenoid valve : Required.  
l) Shut off class : Class IV  
m) Make : As per vendor list enclosed with the enquiry.



## **8.0. IMPULSE PIPING, TUBING, FITTINGS, VALVES AND VALVE MANIFOLDS**

1.01 All impulse pipe shall be of seamless type SS316 material.

1.02 The necessary root valves, impulse piping, drain cocks, gauge-zeroing cocks, valve manifold and all the other accessories required for mounting/erection of the local instruments shall be furnished, even if not specifically asked for, on as required basis. The instrument fittings shall be of forged SS. Instrument piping shall be designed for maximum design pressure & temperature of the process. Pressure instrument connection shall be ½” or 12 mm pipe connection. The contacts of equipment mounted instruments, sensors, switches etc for external connection including spare contacts shall be wired out to the LCP.

1.03 The valve manifolds shall be of 316 stainless steel with pressure rating suitable for intended application. 2-valve manifold and 3-valve manifold shall be used for pressure measurements using pressure transmitters/ pressure switches and differential pressure transmitter/ switches respectively. 5-valve manifold shall be used for remaining applications like DP, flow and level measurements.

1.04 For Pr. / D.P gauges in fluid application two-way globe valve on each impulse line to the instrument and in Air / Flue gas application two-way gate valve on each impulse line to the instrument shall be provided near the instrument. These shall be in addition to the three ways gauge cock provided along with the pr./D.P gauges.

1.05 All the threaded tube fittings used in the plant shall be of the NPT type threading. All the tapping points and pipe to tube joints shall also be using the NPT type threading. Any deviation from the NPT type threading shall be Notified to the Customer specifically for the ease of the maintenance.

1.06 Tube Fittings:

1.06.1 All the threaded tube fittings used in the plant shall be of Stainless Steel double compression type.

1.06.2 All fittings used in the impulse tubing / piping except the last fitting connecting the instrument shall be socket welded.

### **2.00 AIR SUPPLY PIPING**

2.01. All pneumatic piping, fittings, valves, air filter cum regulator, purge rotameter and other accessories required for instrument air for the various pneumatic devices/instruments shall be provided.

2.02 This will include as a minimum air supply to pneumatically operated control valves, actuators, instruments, continuous and intermittent purging requirements etc.

2.03. For individual supply line and control signal line to control valve, 1/4-inch size light drawn tempered copper tubing conforming to ASTM B75 shall be



used. The thickness of cu-tubing shall not be less than 0.065 inch and shall be PVC coated. The fittings to be used with copper tubes shall be of cast brass, screwed type.

- 2.04 All other air supply lines of 1/2 inch to 2 inch shall be of mild steel hot dipped galvanized inside and outside as per IS-1239, heavy duty with threaded ends. The threads shall be as per ASA B.2.1. Fittings material shall be of forged carbon steel A234 Gr. WPB galvanized inside and outside, screwed as per ASA B2.1. Dimensions of fittings shall be as per ASA B16.11 of rating 3000 lbs.
- 2.05. All instrument air filters cum regulator set with mounting accessories shall be provided for each pneumatic device requiring air supply. The filter regulators shall be suitable for 10-kg/ sq.cm max. inlet pressure. The filter shall be of size 5 microns and of material sintered bronze. The air set shall have 2-inch size pressure gauge and built in filter housing blowdown valve. The end connection shall be 1/4 inch / 1/2 inch/ 3/4 inch NPT as per the requirement to be finalised during detailed engineering.
- 2.06 All the isolation valves in the air supply line shall be gate valves as per ASTM B62 inside screw rising stem, screwed female ends as per ASA B2.1. Valve bonnet shall be union type & trim material shall be stainless steel, body rating 150 pounds ASA. The valve sizes shall be ½ inch to 2 inch.

### **3.00 INSTALLATION AND ROUTING**

- 3.01. All instrument piping, tubing and its accessories shall be supported in a safe manner to prevent excessive vibrations and anchored sufficiently to prevent undue strain on connected equipment. Instrument piping & tubing shall not be routed across equipment removal areas, above or below monorails, cranes, removable gratings, cable trays.

#### **3.02. Instrument Air & Service Air Piping/ Tubing System**

The air supply headers, sub-headers and branch pipes shall be supported properly by clamps or supports to be provided and fabricated by the Bidder. Air supply piping shall be installed with a slope of over 1/100 to prevent accumulation of condensed water within the pipe. Signal/control air tubings shall run with the minimum number of changes in direction. Suitable identification tags shall be provided for easy link up and checking of proper connections. Single and multi tubes shall run with the minimum number of changes in direction. Suitable identification tags shall be provided for easy check-up and for connections.

### **4.00. PIPING/ TUBING SUPPORT**

- 4.01. Impulse piping and sample piping shall be supported at an interval not exceeding 1.5 meters. Each pipe shall be supported individually using slotted angle mounted clamps with necessary fixtures. Tubing shall run in proper perforated trays with proper cover. Tubing shall be supported inside the trays



by aluminium supports. Hangers and other fixtures required for support of piping and trays shall be provided, either by welding or by bolting on walls, ceilings and structures. Hanger clamps and other fastening hardware shall be of corrosion resistant metals and hot-dip galvanized.

## **5.00 Cable trays, support systems and pipes**

### **5.01 Support system**

Cable trays/junction box/SVEB supports shall be made of MS angles/channels cut to size and welded at site to suit the requirement.

### **5.02 Type of cable trays**

Material of cable tray Shall be Rolled mild steel, min. 2.5 mm thick for trays and 3mm thick for coupler plate. Finish of cable trays Shall be hot dip galvanized Trays. Length of the cable trays shall be 2.5 metres.

5.03. The cable sub-trays and the supporting system, to be generally used between Local/ Group JBs and the main cable trays and the same shall be furnished and installed by the Bidder. It is the assembly of sections and associated fittings forming a rigid structural system used to support the cable from the equipment or instrument enclosure up to the main cable trays (trunk route).

5.04 The covers on the cable sub-trays shall be used for protection of cables in areas where damage may occur from falling objects, welding spark, corrosive environment, etc. & shall be electrically continuous and solidly grounded. The cable trays shall not have sharp edges, burrs or projections injurious to the insulation or outer sheath of the cables.

5.05 The supporting arrangement of cable tray system shall be able to withstand the weight of the cable and cable tray system. The supporting interval shall not be more than the recommended span for the above loading for the type of cable tray selected. The tray shall not overhang by more than one meter from the support at the dead end. As far as practicable the cable sub-tray system shall be supported from one side only, in order to facilitate installation and maintenance of cables.

### **5.06 Pipe size & type**

Shall be Suitable with 40% fill criteria. GI conduits shall be of heavy duty confirming to IS: 9537.

### **5.07 Cable lugs and ferrules**

Lugs and ferrules for aluminium Bidder cables shall be aluminium solder less crimping type. Copper cable lug/ ferrule shall be solder less tinned copper crimping type.

### **5.08 Cable clamping**

All cables laid on trays shall be neatly dressed up & suitably clamped/tied to the tray. For cables in trefoil formation, trefoil clamps shall be provided.



**9.0. BILL OF QUANTITY E,C & I ITEMS FOR MB SYSTEM**

| <b>BILL OF QUANTITY</b> |                                                                                                        |                     |             |
|-------------------------|--------------------------------------------------------------------------------------------------------|---------------------|-------------|
| <b>Sl. No.</b>          | <b>Description</b>                                                                                     | <b>Qty.</b>         | <b>Unit</b> |
| 1                       | Pressure Indicator (PI)                                                                                | 12                  | No.         |
| 2                       | Pressure Switch (PS)                                                                                   | 3                   | No.         |
| 3                       | Pressure Indicating transmitter (PIT)                                                                  | 1                   | No          |
| 4                       | Density Indicator (DI)                                                                                 | 2                   | No.         |
| 5                       | Differential Pressure Switch (DPS)                                                                     | 3                   | No.         |
| 6                       | Flow Indicating Transmitter (FIT) & orifice plates                                                     | 1                   | No.         |
| 7                       | Rotameter (Flow Indicator-FI)                                                                          | 5                   | No.         |
| 8                       | Level Switch (3 element LSL,LSM,LSH)                                                                   | 2                   | No.         |
| 9                       | Level Indicator (LI)                                                                                   | 7                   | No.         |
| 10                      | Level transmitter                                                                                      | 5                   | No.         |
| 11                      | Conductivity Analyser with isolation SOV.                                                              | 1                   | No.         |
| 12                      | PH Analyser                                                                                            | 2                   | No.         |
| 13                      | SS 316 Tube                                                                                            | As per hook up dra. | Mtr         |
| 14                      | SS 316 Fitting                                                                                         | As per hook up dra. | No          |
| 15                      | Ball valve (Isolation Valve)                                                                           | AS required         | No.         |
| 16                      | Copper Tube & Fittings                                                                                 | AS required         |             |
| 17                      | ¼ OD PVC insulated copper tube                                                                         | AS required         | Mtr         |
| 18                      | Brass Fittings                                                                                         | AS required         | No.         |
| 19                      | Digital / Analog Junction box (JB) 12/24/48 way                                                        | AS required         | No.         |
| 20                      | Electrical Junction box (JB) 12/24/48 way                                                              | AS required         | No          |
| 21                      | Soleniod Valve Enclosure Box (SVB)                                                                     | AS required         | No          |
| 22                      | Perforated tray for laying instrument cables, Impulse line & copper tube 100/50 mm L=2.5 mtr tk=2.5 mm | AS required         | Mtr         |
| 23                      | Digital signal PVC Arm cable 2 pairx0.5sqmm (over all shield)                                          | AS required         | Mtrs        |
| 24                      | Analog signal PVC Arm cable 2 pairx0.5sqmm (Individual pair shield & over all shield)                  | AS required         | Mtrs        |
| 25                      | 3C x 2.5 sqmm PVC Arm Cable                                                                            | AS required         | Mtrs        |
| 26                      | Double Compression Cable Glands for PVC Armoured cable                                                 | AS required         | No.         |
| 27                      | 2/8/12 pair x 0.5 sqmm (pair overall shield Copper Conductor)**                                        | AS required         | No.         |



**SPECIFICATION FOR MB SYSTEM**  
**Electrical, Control & Instrumentation**

**SPEC. NO.: ROS 4140**

**REV. NO: 00**

|    |                                                                                   |             |     |
|----|-----------------------------------------------------------------------------------|-------------|-----|
| 28 | 4/8/12 pair x 0.5 sqmm (incividual pair & overall pair shield Copper Conductor)** | AS required | No. |
| 29 | 3 core x 2.5 sqmm Copper Conductor                                                | AS required | No. |
| 30 | 7 core x 2.5 sqmm Copper Conductor **                                             | AS required | No. |
| 31 | Cable Glands for motor & Instruments                                              | AS required | No. |
| 32 | Cable Lugs for motor AL/ATC Lugs                                                  | AS required | No  |
| 33 | Cable Lugs 0.5 & 2.5 mm ATC lugs                                                  | AS required | No  |
| 34 | 2" Pipe                                                                           | AS required | No  |



## **10. MANDATORY & COMMISSIONING SPARES**

### **10.1 MANDATORY SPARE**

For the following instruments, a minimum of one(1) no. or 10% of the quantity of each type and range, whichever is higher shall be provided.

- i. Air Filter Regulator-1 No
- ii. Pressure Transmitter- 1 No
- iii. Level Transmitter- 1 No
- iv. Flow Transmitter-1 No
- v. Differential Pressure Switch -1 No
- vi. Conductivity Analyzer (complete set with sensor)- 1 No
- vii. pH Analyzer (Complete set with sensor)- 1 No
- viii. pH sensor – 1 No (additional)

### **10.2 COMMISSIONING SPARE**

Following instruments shall be supplied as commissioning spares.

- i. pH sensor -1 No
- ii. Density Indicator- 1 no

| ANNEXURE 1 TO ROS 4140 (INSTRUMENTS SCHEDULE) REV. 00 FOR 1 x<br>370 MW YELAHANKA CAPP |   |     |    |    |     | Ref PID:1WT22000711                                                    |             |      |
|----------------------------------------------------------------------------------------|---|-----|----|----|-----|------------------------------------------------------------------------|-------------|------|
|                                                                                        |   |     |    |    |     | DATE                                                                   | 18/06/2016  |      |
|                                                                                        |   |     |    |    |     | Types of Insts.                                                        |             |      |
| 1                                                                                      | 9 | GCF | 20 | CP | 101 | DEGASSER BLOWER-A OUTLET PRESSURE SWITCH                               | 9GCF20CP101 | PS   |
| 2                                                                                      | 9 | GCF | 21 | CP | 101 | DEGASSER BLOWER-B OUTLET PRESSURE SWITCH                               | 9GCF21CP101 | PS   |
| 3                                                                                      | 9 | GCF | 23 | CL | 501 | DEGASSED WATER STORAGE TANK LEVEL INDICATOR                            | 9GCF23CL501 | LI   |
| 4                                                                                      | 9 | GCF | 23 | CL | 001 | DEGASSED WATER STORAGE TANK LEVEL INDICATING TRANSMITTER               | 9GCF23CL001 | LIT  |
| 5                                                                                      | 9 | GCF | 25 | CP | 001 | MIXED BED FEED PUMP- A OUTLET LINE PRESSURE INDICATOR                  | 9GCF25CP001 | PI   |
| 6                                                                                      | 9 | GCF | 26 | CP | 001 | MIXED BED FEED PUMP- B OUTLET LINE PRESSURE INDICATOR                  | 9GCF26CP001 | PI   |
| 7                                                                                      | 9 | GCF | 28 | CP | 001 | MIXED BED INLET PRESSURE INDICATING TRANSMITTER                        | 9GCF28CP001 | PIT  |
| 8                                                                                      | 9 | GCF | 28 | CF | 501 | MIXED BED INLET FLOW INDICATOR                                         | 9GCF28CF501 | FI   |
| 9                                                                                      | 9 | GCF | 28 | CP | 501 | MIXED BED FEED INLET PRESSURE INDICATOR                                | 9GCF28CP501 | PI   |
| 10                                                                                     | 9 | GCF | 28 | PD | 101 | MIXED BED DIFFERENTIAL PRESSURE SWITCH                                 | 9GCF28PD101 | DPS  |
| 11                                                                                     | 9 | GCF | 28 | CP | 502 | MIXED BED PRODUCT OUTLET LINE PRESSURE INDICATOR                       | 9GCF28CP502 | PI   |
| 12                                                                                     | 9 | GCF | 28 | PD | 102 | MIXED BED PRODUCT OUTLET LINE RESIN TRAP DIFFERENTIAL PRESSURE SWITCH  | 9GCF28PD102 | DPS  |
| 13                                                                                     | 9 | GCF | 28 | PD | 103 | MIXED BED BACKWASH OUTLET LINE RESIN TRAP DIFFERENTIAL PRESSURE SWITCH | 9GCF28PD103 | DPS  |
| 14                                                                                     | 9 | GCF | 28 | CQ | 002 | MIXED BED PRODUCT OUTLET LINE pH ANALYSER                              | 9GCF28CQ002 | PH   |
| 15                                                                                     | 9 | GCF | 28 | CQ | 001 | MIXED BED PRODUCT OUTLET LINE CONDUCTIVITY ANALYSER                    | 9GCF28CQ001 | COND |
| 16                                                                                     | 9 | GCF | 28 | AA | 115 | MIXED BED PRODUCT OUTLET LINE CONDUCTIVITY ANALYSER SAMPLE VALVE       | 9GCF28AA115 | SOV  |
| 17                                                                                     | 9 | GCF | 29 | CF | 001 | MIXED BED PRODUCT OUTLET LINE FLOW INDICATING TRANSMITTER              | 9GCF29CF001 | FIT  |
| 18                                                                                     | 9 | GCF | 30 | CP | 501 | MB AIR BLOWER- A OUTLET LINE PRESSURE INDICATOR                        | 9GCF30CP501 | PI   |
| 19                                                                                     | 9 | GCF | 31 | CP | 501 | MB AIR BLOWER- B OUTLET LINE PRESSURE INDICATOR                        | 9GCF31CP501 | PI   |
| 20                                                                                     | 9 | GCF | 32 | CP | 101 | MB AIR BLOWER COMMON OUTLET PRESSURE SWITCH                            | 9GCF32CP101 | PS   |
| 21                                                                                     | 9 | GCP | 02 | CP | 501 | MIXED BED REGENERATION PUMP- A OUTLET LINE PRESSURE INDICATOR          | 9GCP02CP501 | PI   |
| 22                                                                                     | 9 | GCP | 03 | CP | 501 | MIXED BED REGENERATION PUMP- B OUTLET LINE PRESSURE INDICATOR          | 9GCP03CP501 | PI   |
| 23                                                                                     | 9 | GCP | 04 | CF | 501 | MIXED BED REGENERATION PUMP OUTLET LINE FLOW INDICATOR                 | 9GCP04CF501 | FI   |
| 24                                                                                     | 9 | GCP | 04 | CF | 502 | MIXED BED UPFLOW/DOWNFLOW INLET LINE FLOW INDICATOR                    | 9GCP04CF502 | FI   |
| 25                                                                                     | 9 | GCP | 09 | CL | 001 | BULK ALKALI STORAGE TANK LEVEL TRANSMITTER                             | 9GCP09CL001 | LIT  |
| 26                                                                                     | 9 | GCP | 09 | CL | 501 | BULK ALKALI STORAGE TANK LEVEL INDICATOR                               | 9GCP09CL501 | LI   |
| 27                                                                                     | 9 | GCP | 06 | CP | 501 | ALKALI UNLOADING PUMP-1 OUTLET LINE PRESSURE INDICATOR                 | 9GCP06CP501 | PI   |
| 28                                                                                     | 9 | GCP | 07 | CP | 501 | ALKALI UNLOADING PUMP-2 OUTLET LINE PRESSURE INDICATOR                 | 9GCP07CP501 | PI   |
| 29                                                                                     | 9 | GCP | 10 | CL | 501 | CAUSTIC DILUTION TANK LEVEL INDICATOR                                  | 9GCP10CL501 | LI   |
| 30                                                                                     | 9 | GCP | 10 | CL | 101 | CAUSTIC DILUTION TANK LEVEL SWITCH (L, M, H)                           | 9GCP10CL101 | LS   |
| 31                                                                                     | 9 | GCP | 11 | CF | 502 | CAUSTIC DILUTION TANK EJECTOR OUTLET LINE FLOW INDICATOR               | 9GCP11CF502 | FI   |
| 32                                                                                     | 9 | GCP | 11 | CD | 501 | CAUSTIC DILUTION TANK EJECTOR OUTLET LINE DENSITY INDICATOR            | 9GCP11CD501 | DI   |
| 33                                                                                     | 9 | GCP | 16 | CL | 501 | BULK ACID STORAGE TANK LEVEL INDICATOR                                 | 9GCP16CL501 | LI   |
| 34                                                                                     | 9 | GCP | 16 | CL | 001 | BULK ACID STORAGE TANK LEVEL TRANSMITTER                               | 9GCP16CL001 | LIT  |
| 35                                                                                     | 9 | GCP | 13 | CP | 501 | ACID UNLOADING PUMP-1 OUTLET LINE PRESSURE INDICATOR                   | 9GCP13CP501 | PI   |
| 36                                                                                     | 9 | GCP | 14 | CP | 501 | ACID UNLOADING PUMP-2 OUTLET LINE PRESSURE INDICATOR                   | 9GCP14CP501 | PI   |
| 37                                                                                     | 9 | GCP | 17 | CL | 501 | ACID MEASURING TANK LEVEL INDICATOR                                    | 9GCP17CL501 | LI   |
| 38                                                                                     | 9 | GCP | 17 | CL | 101 | ACID MEASURING TANK LEVEL SWITCH (L,M,H)                               | 9GCP17CL101 | LS   |
| 39                                                                                     | 9 | GCP | 18 | CF | 501 | ACID MEASURING TANK EJECTOR OUTLET LINE FLOW INDICATOR                 | 9GCP18CF501 | FI   |
| 40                                                                                     | 9 | GCP | 18 | CD | 501 | ACID MEASURING TANK EJECTOR OUTLET LINE DENSITY INDICATOR              | 9GCP18CD501 | DI   |
| 41                                                                                     | 9 | GCR | 01 | CL | 001 | NEUTRALISING PIT LEVEL INDICATING TRANSMITTER                          | 9GCR01CL001 | LIT  |
| 42                                                                                     | 9 | GCR | 02 | CL | 001 | NEUTRALISING PIT LEVEL INDICATING TRANSMITTER                          | 9GCR02CL001 | LIT  |
| 43                                                                                     | 9 | GCR | 04 | CP | 501 | NEUTRALISING PUMP-1 OUTLET LINE PRESSURE INDICATOR                     | 9GCR04CP501 | LI   |
| 44                                                                                     | 9 | GCR | 06 | CP | 501 | NEUTRALISING PUMP-2 OUTLET LINE PRESSURE INDICATOR                     | 9GCR06CP501 | LI   |
| 45                                                                                     | 9 | GCR | 07 | CQ | 001 | NEUTRALISING PUMPS OUTLET pH ANALYSER                                  | 9GCR07CQ001 | PH   |

CAUTION: The information on this document is the property of BHARAT HEAVY ELECTRICALS LTD. It must not be used directly or indirectly in any way detrimental to the interest of the company.

ALL DIMENSIONS ARE IN MILLIMETRES

|                                                                                   |
|-----------------------------------------------------------------------------------|
| FOR PRODUCTION<br>REF.-PR:QA:590 FOR PAINTING<br>REF.-PR:QA:500 FOR UNTOL. DIMNS. |
|-----------------------------------------------------------------------------------|

## INSTALLATION INSTRUCTIONS

1. IDENTIFY EACH INSTRUMENT IN THE UF- RO- DM PLANT WITH "P & ID DIAGRAM"
2. FOR INSTRUMENTS TO BE LOCATED DIRECTLY ON THE PIPE LINE OR VESSEL/TANK REFER THE RELEVANT PIPING/TANK ASSY. DRAWING.
3. FOR INSTRUMENTS LOCATED AWAY FROM THE PIPE LINE/TANK (ie. NOT DIRECT MOUNTED) REFER TO INSTALLATION SCHEME DRAWINGS.
- 4 THE IMPULSE LINE SHALL BE ROUTED THROUGH PERFORATED CABLE TRAY WITH SUITABLE SUPPORTS.
- 5 DRAIN LINE ARE TO BE CONNECTED IN THE DRAIN TRENCH

| REV  | DATE     | ALTERED          | IRS |
|------|----------|------------------|-----|
| 01   | 04.12.12 | CHECKED          | RPS |
| ZONE |          | NOTE 4 & 5 ADDED |     |

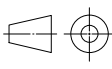
|                                                                                     |                                                                                                |                                                                                     |       |              |                        |      |          |                 |
|-------------------------------------------------------------------------------------|------------------------------------------------------------------------------------------------|-------------------------------------------------------------------------------------|-------|--------------|------------------------|------|----------|-----------------|
|  | <b>BHARAT HEAVY ELECTRICALS LTD.,</b><br>UNIT: BOILER AUXILIARIES PLANT,<br>RANIPET - 632 406. |                                                                                     |       | DRN          | NAME                   | SIGN | DATE     | NO.OF<br>VAR    |
|                                                                                     |                                                                                                |                                                                                     |       | CHD          | ACK                    |      |          |                 |
|                                                                                     |                                                                                                |                                                                                     |       | APPD         | RPS                    |      |          |                 |
| DEPT<br>DCI                                                                         | GRADE OF<br>UNTOL.DIM                                                                          |  | SCALE | WEIGHT (KG). | REF. TO ASSY./OLD DRG. |      | ITEM NO. | NO. OF<br>ITEMS |
| CODE                                                                                | PR:QA:500                                                                                      |                                                                                     |       |              |                        |      |          |                 |
| TITLE                                                                               |                                                                                                |                                                                                     |       | CARD<br>CODE | DRAWING NO.            |      |          | REV             |
| <b>INSTALLATION INSTRUCTIONS</b><br><b>(TYPICAL)</b>                                |                                                                                                |                                                                                     |       | U 01         | <b>4-WT-310-00017</b>  |      |          | <b>01</b>       |

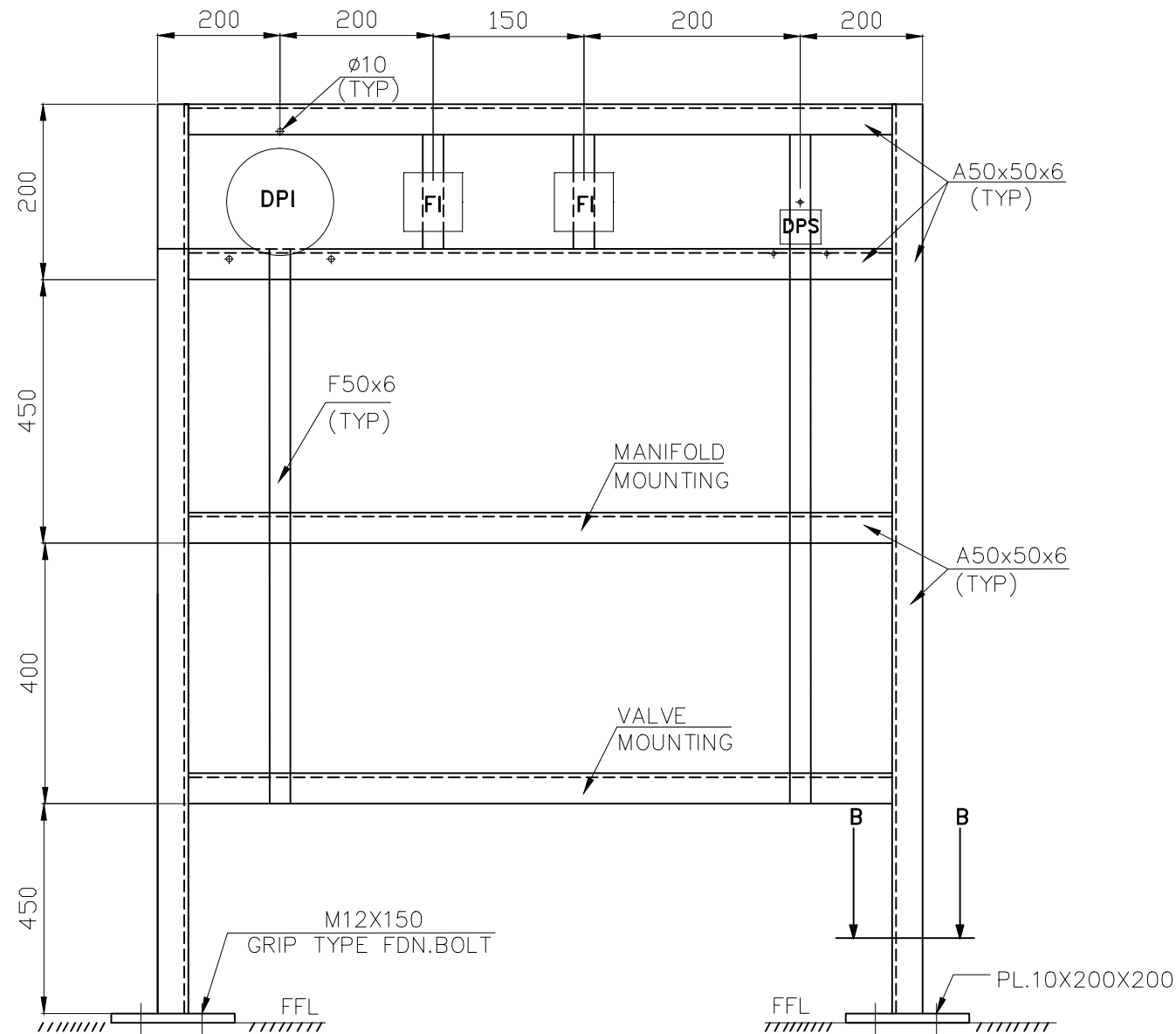

**NOTE: -**

- 1. THE FRAME SHALL BE FABRICATED AT SITE.
- 2. INSTRUMENT MOUNTING HOLE DIA IN THE FRAME SHALL BE  $\phi 10$ .

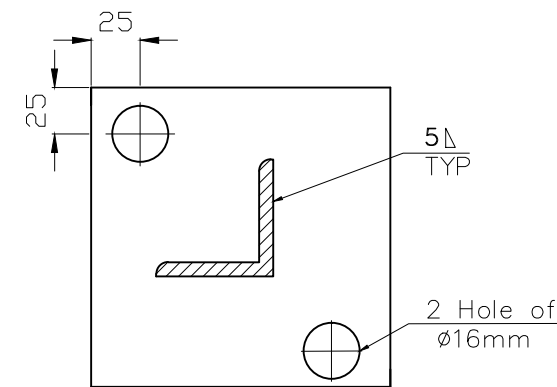

**SECTION-BB**



**BHARAT HEAVY ELECTRICALS LTD**

UNIT : BOILER AUXILIARIES PLANT

RANIPET-632 406

|                                                                                                                                                                                                                             |  |              |             |             |      |      |
|-----------------------------------------------------------------------------------------------------------------------------------------------------------------------------------------------------------------------------|--|--------------|-------------|-------------|------|------|
| COPY RIGHT AND CONFIDENTIAL<br>The information on this document is the property of<br>BHARAT HEAVY ELECTRICALS LIMITED it Must not be used directly or<br>indirectly in any way detrimental to the interest of the company. |  | DEPT<br>CODE | DRN<br>DESN | NAME<br>ACK | SIGN | DATE |
|                                                                                                                                                                                                                             |  | 876          | CHD         | RPS         |      |      |
|                                                                                                                                                                                                                             |  |              | APPD        | DNB         |      |      |

| REV | DATE | ALTERED |  |
|-----|------|---------|--|
| 01  |      | CHECKED |  |

TITLE  
**INSTRUMENT MOUNTING FRAME ARRANGEMENT (TYPICAL)**

|      |  |
|------|--|
| ZONE |  |
|------|--|

|       |       |     |                       |
|-------|-------|-----|-----------------------|
| DEPT. | SCALE | NTS | DRAWING NO.           |
| SIGN  |       |     | <b>3-WT-310-00012</b> |
| DATE  |       |     | SHEET 1 OF 1 REV. 00  |

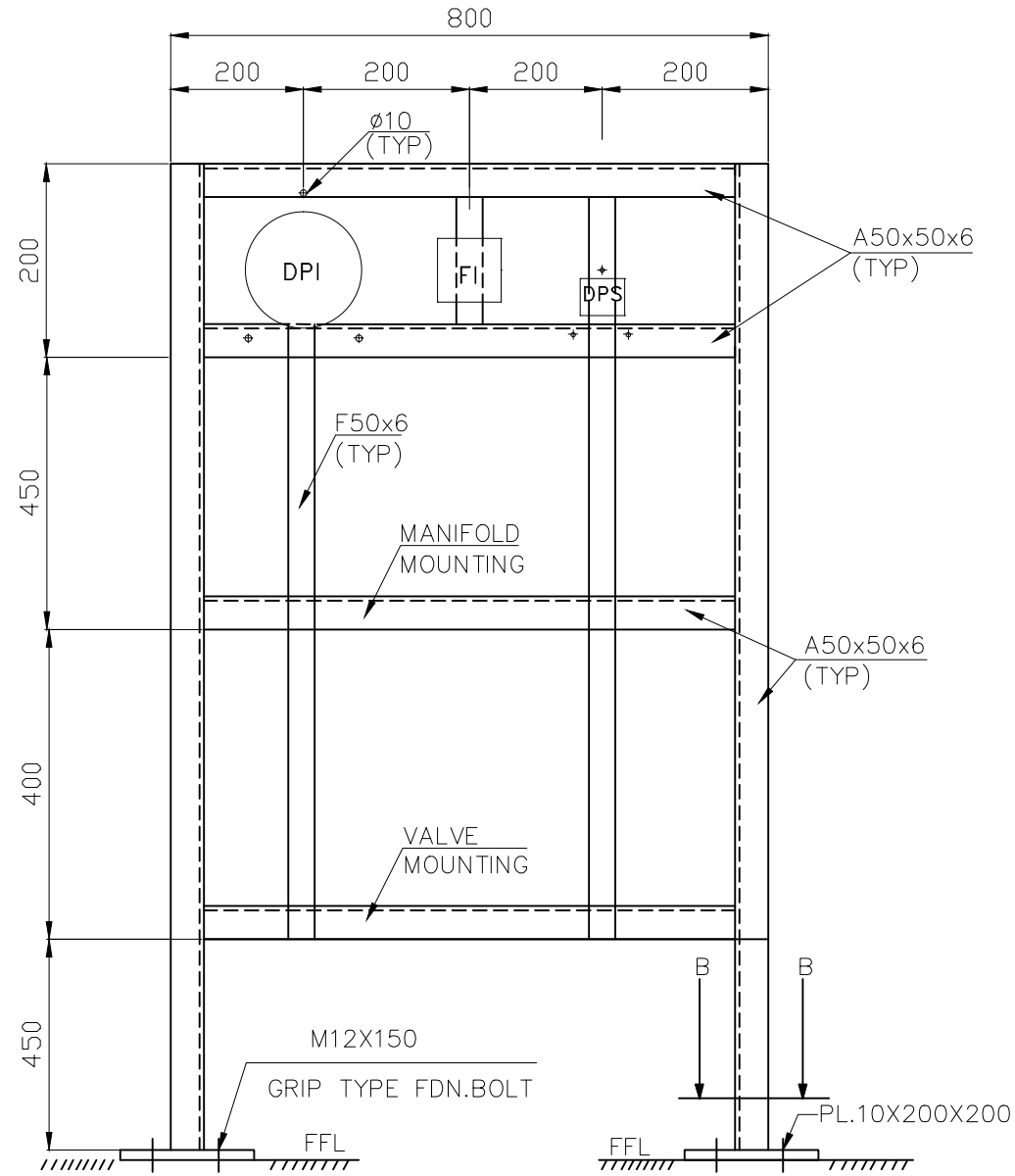

**NOTE: -**

1. THE FRAME SHALL BE FABRICATED AT SITE.
2. INSTRUMENT MOUNTING HOLE DIA IN THE FRAME SHALL BE  $\phi 10$ .

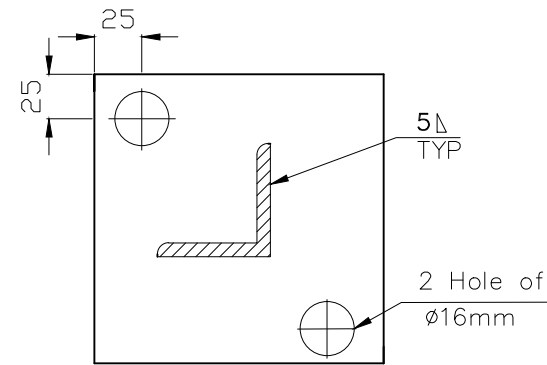

SECTION-BB



**BHARAT HEAVY ELECTRICALS LTD**  
 UNIT : BOILER AUXILIARIES PLANT  
 RANIPET-632 406

|                                                                                                                                                                                                                       |  |  |  |  |              |             |             |      |      |
|-----------------------------------------------------------------------------------------------------------------------------------------------------------------------------------------------------------------------|--|--|--|--|--------------|-------------|-------------|------|------|
| COPY RIGHT AND CONFIDENTIAL<br>The information on this document is the property of BHARAT HEAVY ELECTRICALS LIMITED it must not be used directly or indirectly in any way detrimental to the interest of the company. |  |  |  |  | DEPT<br>CODE | DRN<br>DESN | NAME<br>ACK | SIGN | DATE |
|                                                                                                                                                                                                                       |  |  |  |  | 876          | CHD         | RPS         |      |      |
|                                                                                                                                                                                                                       |  |  |  |  |              | APPD        | DNB         |      |      |

| REV | DATE | ALTERED | CHECKED |
|-----|------|---------|---------|
| 01  |      |         |         |

|      |  |
|------|--|
| ZONE |  |
|------|--|

TITLE  
**INSTRUMENT MOUNTING FRAME ARRANGEMENT (TYPICAL)**

|       |       |     |                       |
|-------|-------|-----|-----------------------|
| DEPT. | SCALE | NTS | DRAWING NO.           |
| SIGN  |       |     | <b>3-WT-310-00013</b> |
| DATE  |       |     | SHEET 1 OF 1 REV. 00  |

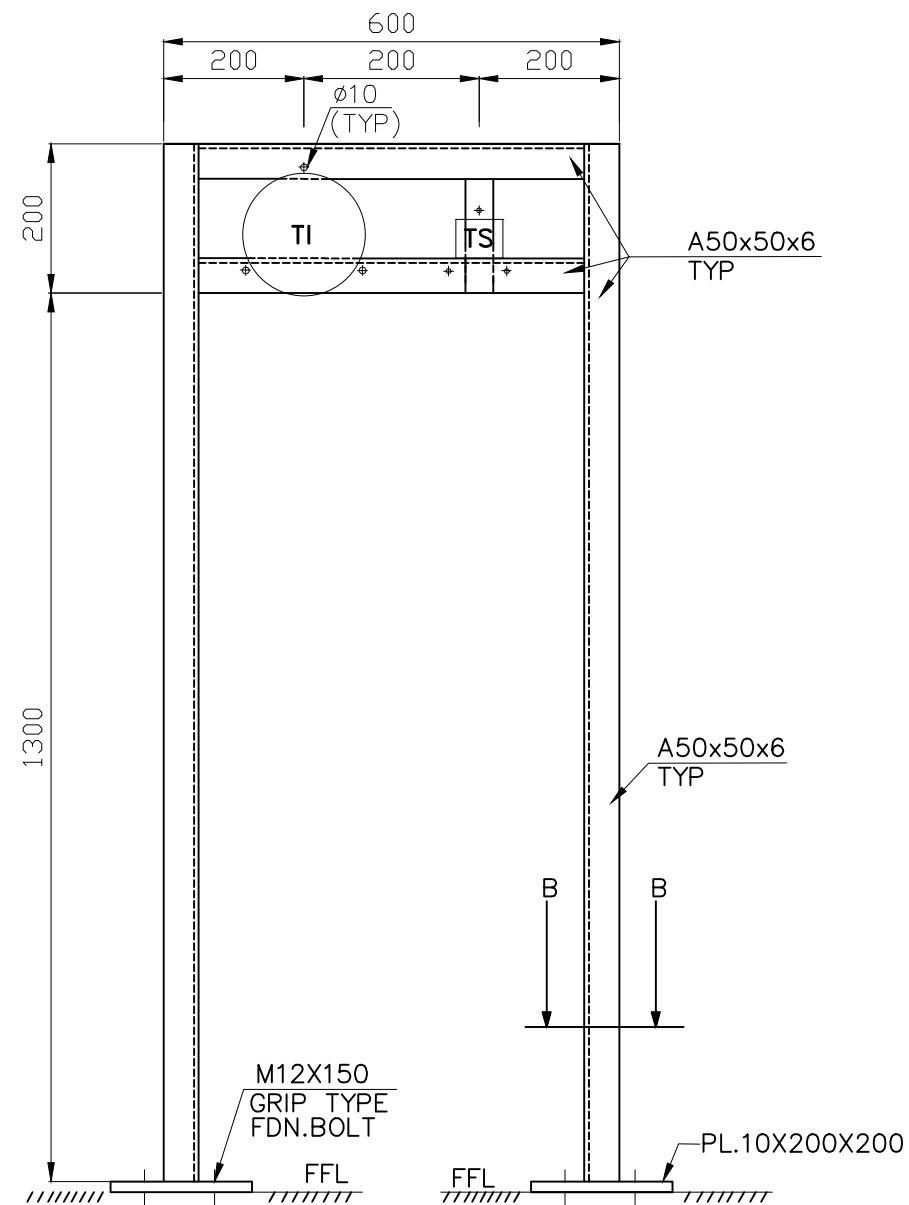

**NOTE: -**

1. THE FRAME SHALL BE FABRICATED AT SITE.
2. INSTRUMENT MOUNTING HOLE DIA IN THE FRAME SHALL BE  $\phi 100$ .

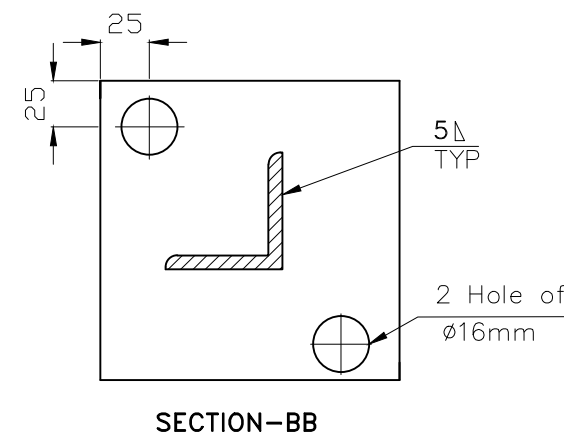

**BHARAT HEAVY ELECTRICALS LTD**  
 UNIT : BOILER AUXILIARIES PLANT  
 RANIPET-632 406

|                                                                                                                                                                                                                       |  |              |             |             |      |      |
|-----------------------------------------------------------------------------------------------------------------------------------------------------------------------------------------------------------------------|--|--------------|-------------|-------------|------|------|
| COPY RIGHT AND CONFIDENTIAL<br>The information on this document is the property of BHARAT HEAVY ELECTRICALS LIMITED it Must not be used directly or indirectly in any way detrimental to the interest of the company. |  | DEPT<br>CODE | DRN<br>ACK  | NAME<br>ACK | SIGN | DATE |
|                                                                                                                                                                                                                       |  | 876          | CHD<br>APPD | RPS<br>DNB  |      |      |

| REV  | DATE | ALTERED |  |
|------|------|---------|--|
| 01   |      | CHECKED |  |
| ZONE |      |         |  |

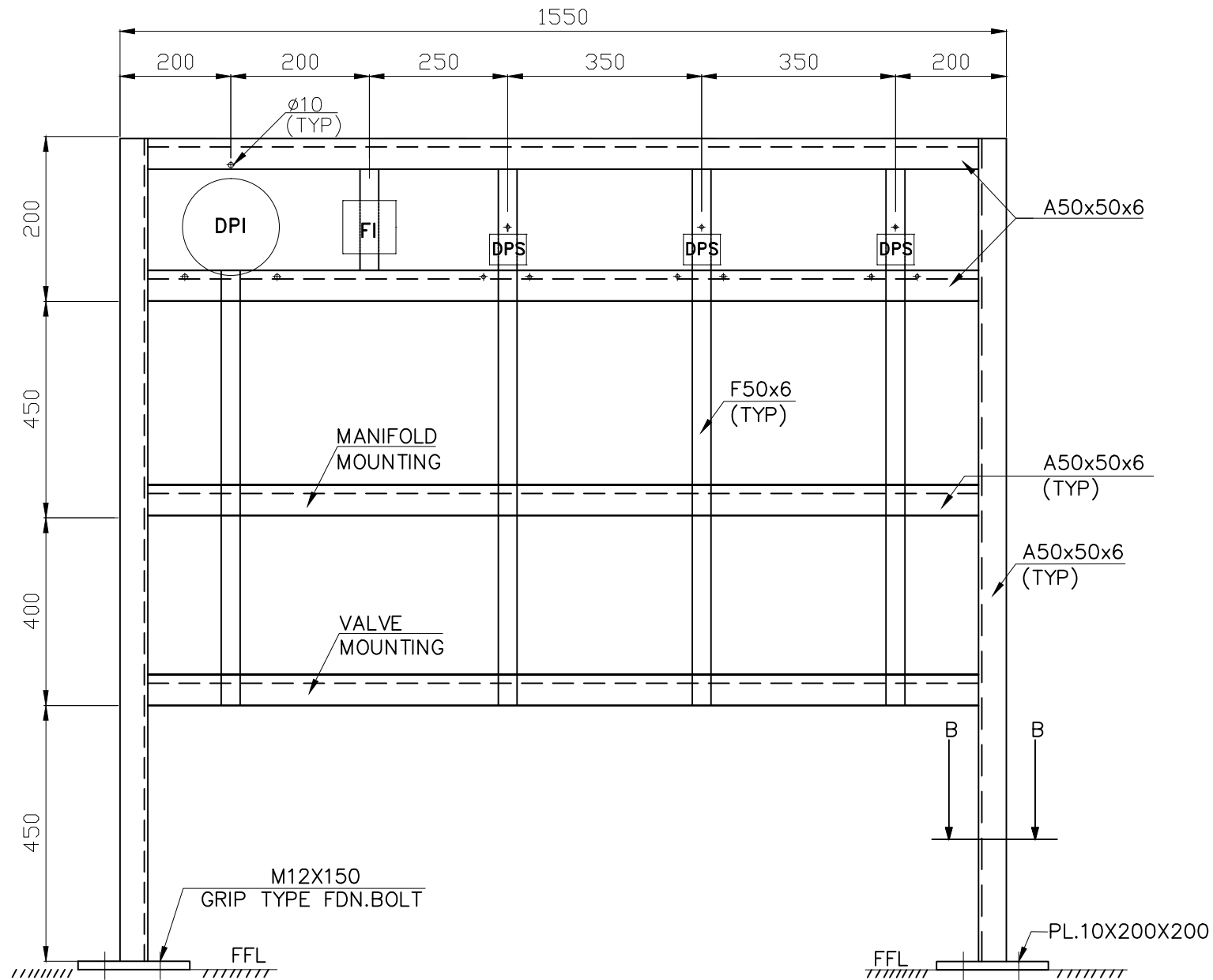

|                                                                 |       |     |                       |      |         |
|-----------------------------------------------------------------|-------|-----|-----------------------|------|---------|
| TITLE<br><b>INSTRUMENT MOUNTING FRAME ARRANGEMENT (TYPICAL)</b> |       |     |                       |      |         |
| DEPT.                                                           | SCALE | NTS | DRAWING NO.           |      |         |
| SIGN                                                            |       |     | <b>3-WT-310-00014</b> |      |         |
| DATE                                                            |       |     | SHEET 1               | OF 1 | REV. 00 |

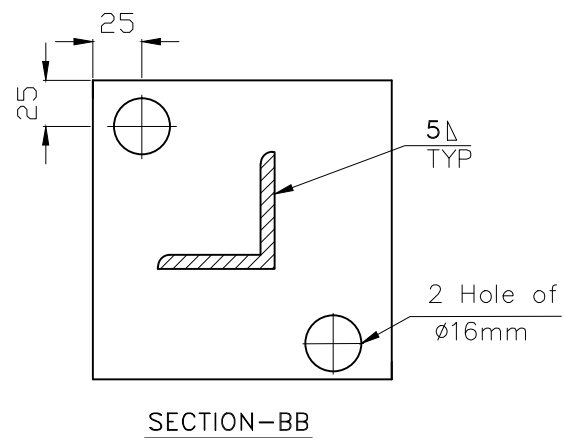

**NOTE: -**

1. THE FRAME SHALL BE FABRICATED AT SITE.
2. INSTRUMENT MOUNTING HOLE DIA IN THE FRAME SHALL BE  $\phi 10$ .



|                                                                                       |                                                                                                                                                                                                                       |          |       |                                                                                       |                       |
|---------------------------------------------------------------------------------------|-----------------------------------------------------------------------------------------------------------------------------------------------------------------------------------------------------------------------|----------|-------|---------------------------------------------------------------------------------------|-----------------------|
|  | <b>BHARAT HEAVY ELECTRICALS LTD</b><br>UNIT : BOILER AUXILIARIES PLANT<br>RANIPET-632 406                                                                                                                             |          |       |                                                                                       |                       |
|                                                                                       | COPY RIGHT AND CONFIDENTIAL<br>The information on this document is the property of BHARAT HEAVY ELECTRICALS LIMITED it Must not be used directly or indirectly in any way detrimental to the interest of the company. |          |       |                                                                                       |                       |
| DEPT CODE                                                                             | DRN                                                                                                                                                                                                                   | NAME ACK | SIGN  | DATE                                                                                  |                       |
| 876                                                                                   | CHD                                                                                                                                                                                                                   | RPS      |       |                                                                                       |                       |
|                                                                                       |                                                                                                                                                                                                                       |          |       |                                                                                       | APPD DNB              |
| TITLE<br><b>INSTRUMENT MOUNTING FRAME ARRANGEMENT (TYPICAL)</b>                       |                                                                                                                                                                                                                       |          |       |                                                                                       |                       |
|                                                                                       |                                                                                                                                                                                                                       | DEPT.    | SCALE | NTS                                                                                   | DRAWING NO.           |
|                                                                                       |                                                                                                                                                                                                                       | SIGN     | DATE  |  | <b>3-WT-310-00015</b> |
|                                                                                       |                                                                                                                                                                                                                       |          |       | SHEET 1 OF 1                                                                          | REV. 00               |

| REV  | DATE | ALTERED | CHECKED |  |
|------|------|---------|---------|--|
| 01   |      | CHECKED |         |  |
| ZONE |      |         |         |  |

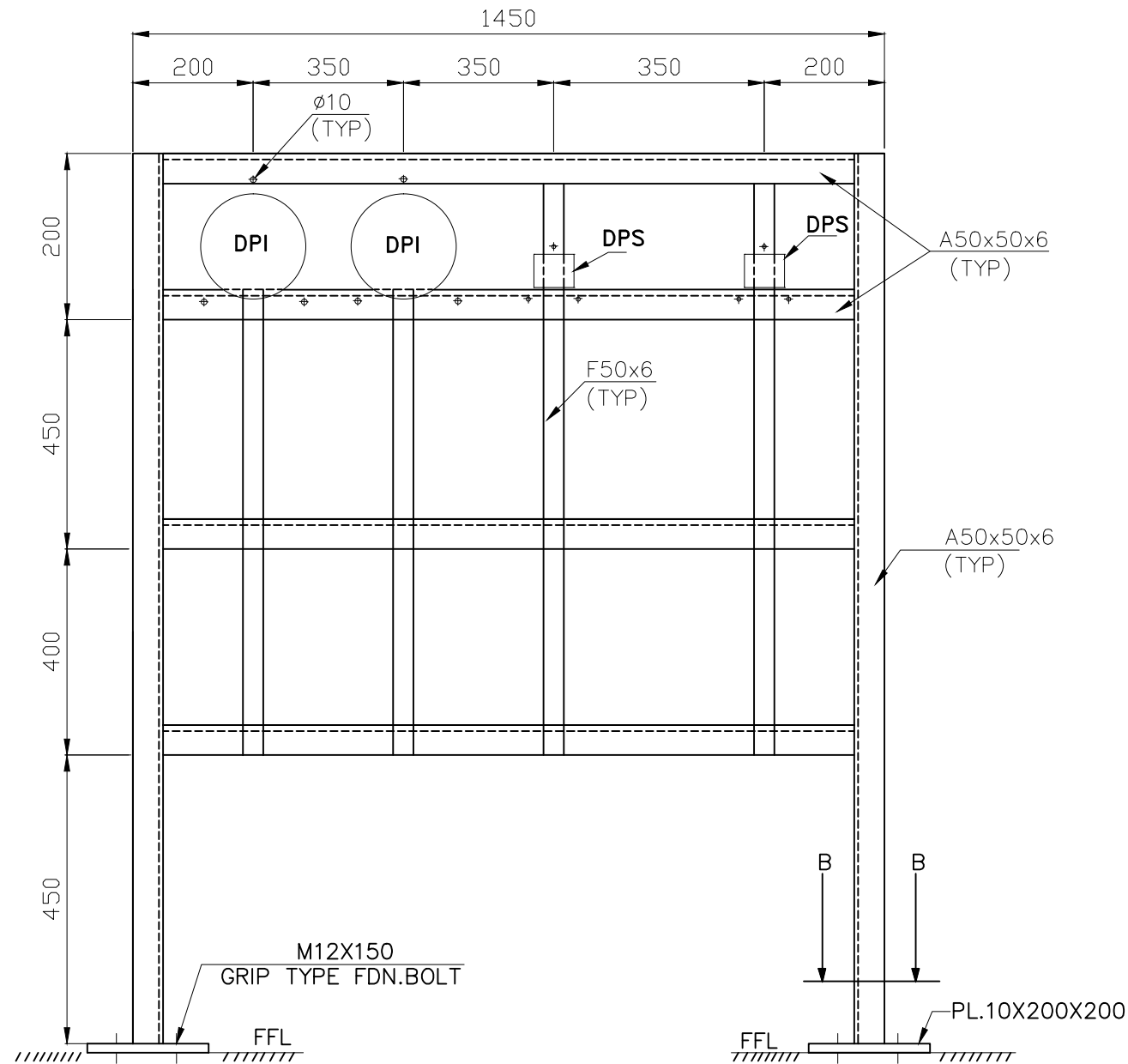

**NOTE: -**

1. THE FRAME SHALL BE FABRICATED AT SITE.
2. INSTRUMENT MOUNTING HOLE DIA IN THE FRAME SHALL BE  $\phi 10$ .

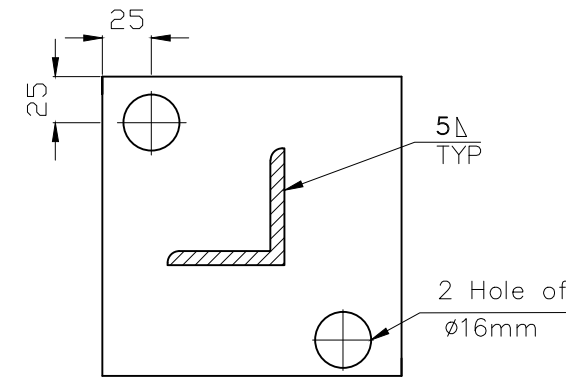

**SECTION-BB**

|                                                                                       |                                                                                                                                                                                                                       |         |           |      |       |       |                       |
|---------------------------------------------------------------------------------------|-----------------------------------------------------------------------------------------------------------------------------------------------------------------------------------------------------------------------|---------|-----------|------|-------|-------|-----------------------|
|  | <b>BHARAT HEAVY ELECTRICALS LTD</b><br>UNIT : BOILER AUXILIARIES PLANT<br>RANIPET-632 406                                                                                                                             |         |           |      |       |       |                       |
|                                                                                       | COPY RIGHT AND CONFIDENTIAL<br>The information on this document is the property of BHARAT HEAVY ELECTRICALS LIMITED it Must not be used directly or indirectly in any way detrimental to the interest of the company. |         |           |      |       |       |                       |
| REV                                                                                   | DATE                                                                                                                                                                                                                  | ALTERED | DEPT CODE | DRN  | NAME  | SIGN  | DATE                  |
| 01                                                                                    |                                                                                                                                                                                                                       | CHECKED | 876       | DESN | ACK   |       |                       |
| ZONE                                                                                  |                                                                                                                                                                                                                       |         |           | CHD  | RPS   |       |                       |
|                                                                                       |                                                                                                                                                                                                                       |         |           | APPD | DNB   |       |                       |
| TITLE <b>INSTRUMENT MOUNTING FRAME ARRANGEMENT (TYPICAL)</b>                          |                                                                                                                                                                                                                       |         |           |      |       |       |                       |
|                                                                                       |                                                                                                                                                                                                                       |         |           |      | DEPT. | SCALE | NTS                   |
|                                                                                       |                                                                                                                                                                                                                       |         |           |      | SIGN  |       | DRAWING NO.           |
|                                                                                       |                                                                                                                                                                                                                       |         |           |      | DATE  |       | <b>3-WT-310-00016</b> |
|                                                                                       |                                                                                                                                                                                                                       |         |           |      |       |       | SHEET 1 OF 1 REV. 00  |

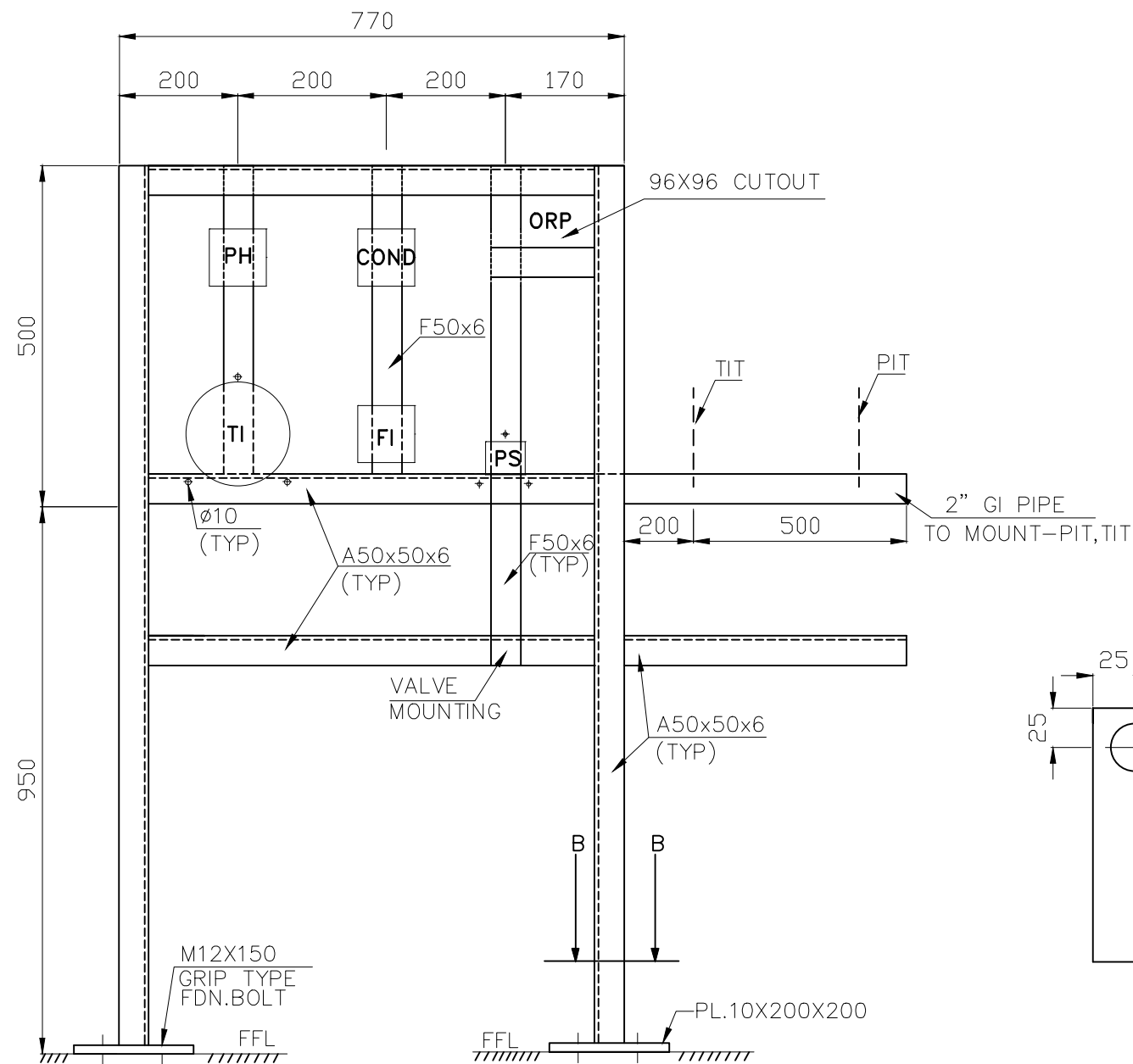

**NOTE: -**

1. THE FRAME SHALL BE FABRICATED AT SITE.
2. INSTRUMENT MOUNTING HOLE DIA IN THE FRAME SHALL BE  $\phi 10$ .

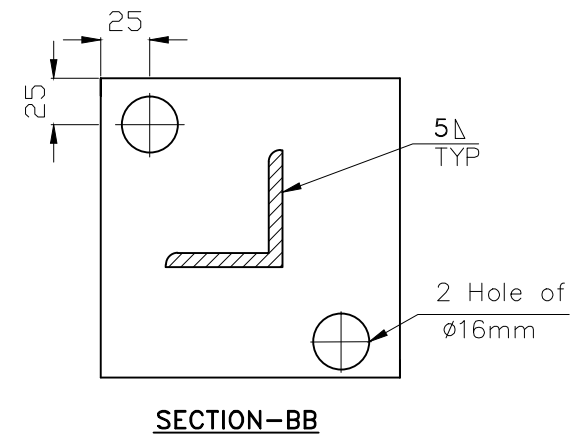

**BHARAT HEAVY ELECTRICALS LTD**  
 UNIT : BOILER AUXILIARIES PLANT  
 RANIPET-632 406

|                                                                                                                                                                                                                       |  |           |      |          |      |      |
|-----------------------------------------------------------------------------------------------------------------------------------------------------------------------------------------------------------------------|--|-----------|------|----------|------|------|
| COPY RIGHT AND CONFIDENTIAL<br>The information on this document is the property of BHARAT HEAVY ELECTRICALS LIMITED it Must not be used directly or indirectly in any way detrimental to the interest of the company. |  | DEPT CODE | DRN  | NAME ACK | SIGN | DATE |
|                                                                                                                                                                                                                       |  | 876       | CHD  | RPS      |      |      |
|                                                                                                                                                                                                                       |  |           | APPD | DNB      |      |      |

| REV | DATE | ALTERED |
|-----|------|---------|
| 01  |      | CHECKED |

TITLE  
**INSTRUMENT MOUNTING FRAME ARRANGEMENT (TYPICAL)**

|      |  |
|------|--|
| ZONE |  |
|------|--|

|       |       |     |                       |
|-------|-------|-----|-----------------------|
| DEPT. | SCALE | NTS | DRAWING NO.           |
| SIGN  |       |     | <b>3-WT-310-00017</b> |
| DATE  |       |     | SHEET 1 OF 1 REV. 00  |

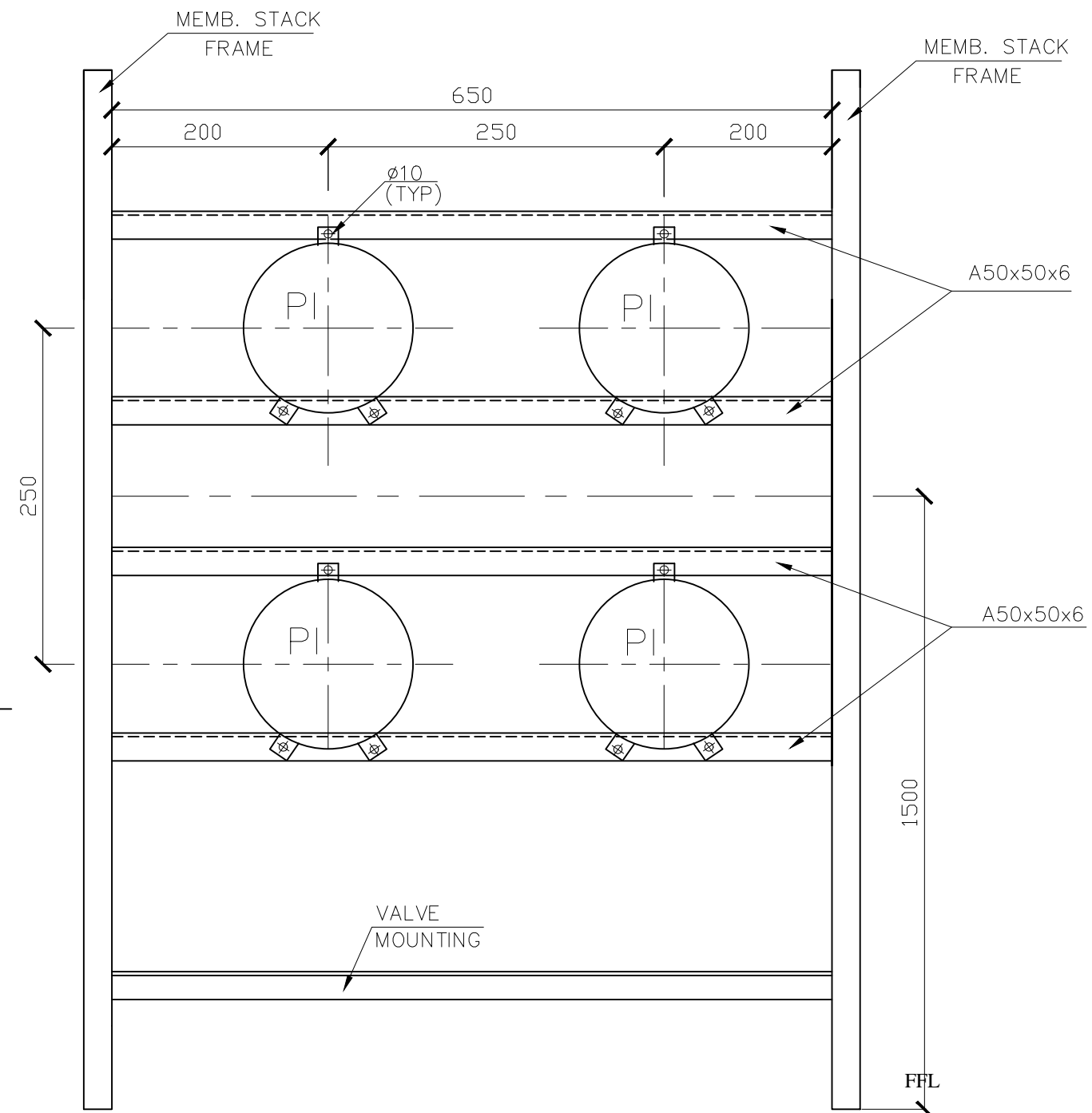

**NOTE: -**

1. THE FRAME SHALL BE FABRICATED AT SITE.
2. INSTRUMENT MOUNTING HOLE DIA IN THE FRAME SHALL BE  $\phi 10$ .



**BHARAT HEAVY ELECTRICALS LTD**

UNIT : BOILER AUXILIARIES PLANT

RANIPET-632 406

|                                                                                                                                                                                                                             |  |              |             |             |      |      |
|-----------------------------------------------------------------------------------------------------------------------------------------------------------------------------------------------------------------------------|--|--------------|-------------|-------------|------|------|
| COPY RIGHT AND CONFIDENTIAL<br>The information on this document is the property of<br>BHARAT HEAVY ELECTRICALS LIMITED it Must not be used directly or<br>indirectly in any way detrimental to the interest of the company. |  | DEPT<br>CODE | DRN<br>DESN | NAME<br>ACK | SIGN | DATE |
|                                                                                                                                                                                                                             |  | 876          | CHD<br>APPD | RPS<br>DNB  |      |      |

| REV | DATE | ALTERED |
|-----|------|---------|
| 01  |      | CHECKED |

TITLE  
**INSTRUMENT MOUNTING FRAME ARRANGEMENT (TYPICAL)**

|      |  |
|------|--|
| ZONE |  |
|------|--|

|       |       |     |                       |
|-------|-------|-----|-----------------------|
| DEPT. | SCALE | NTS | DRAWING NO.           |
| SIGN  |       |     | <b>3-WT-310-00018</b> |
| DATE  |       |     | SHEET 1 OF 1 REV. 00  |

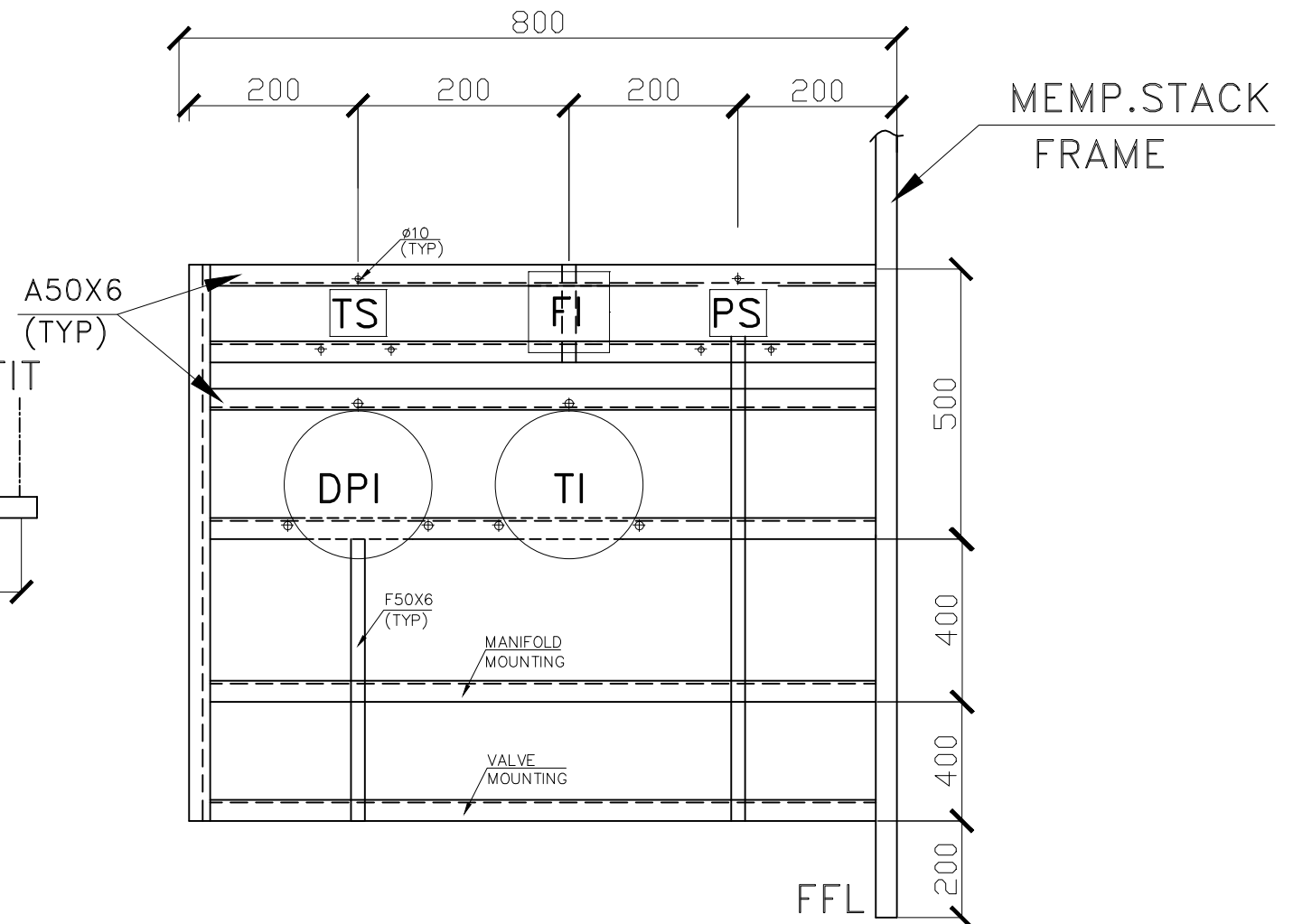
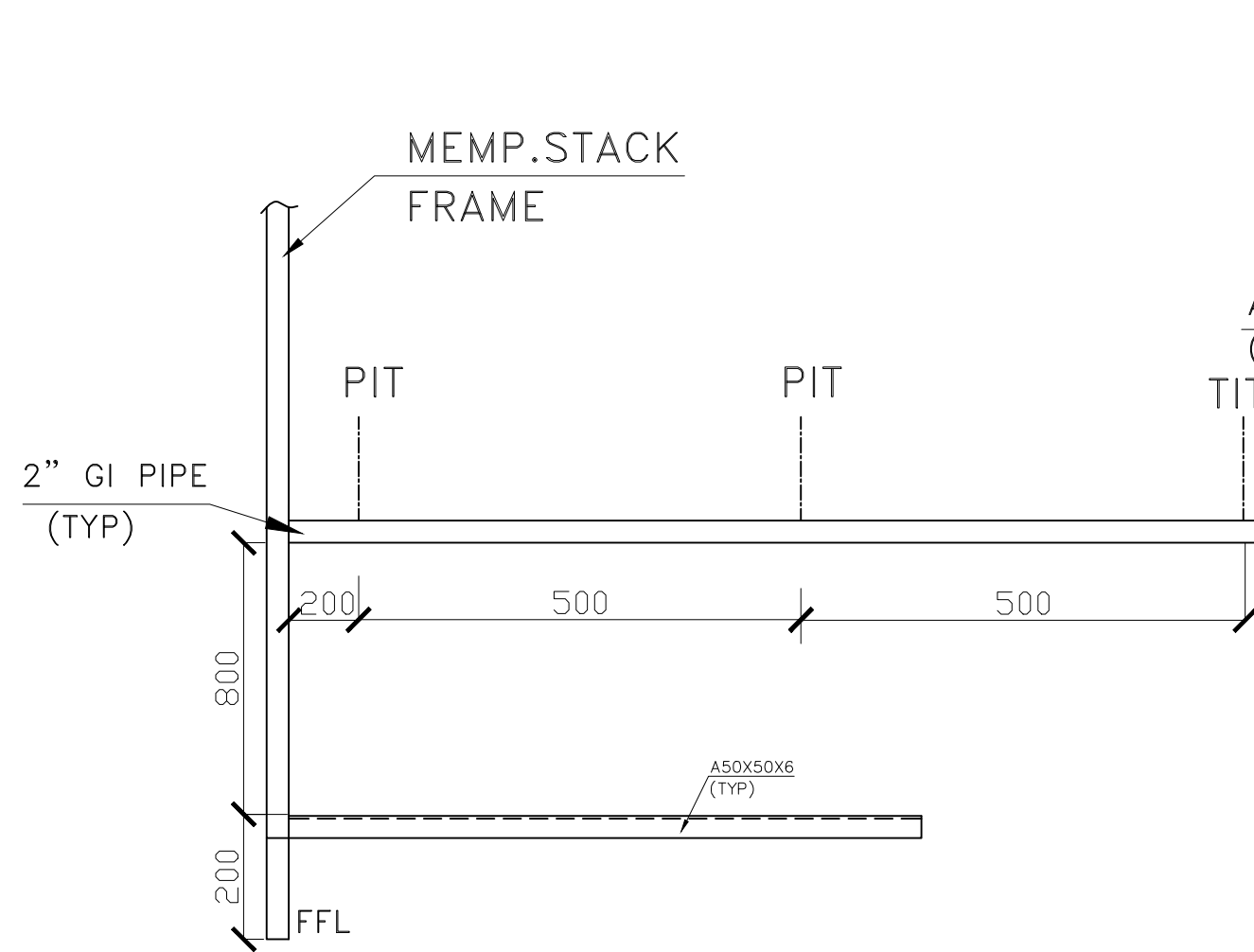

NOTE: -

1. THE FRAME SHALL BE FABRICATED AT SITE.
2. INSTRUMENT MOUNTING HOLE DIA IN THE FRAME SHALL BE  $\phi 10$ .

| REV  | DATE | ALTERED | CHECKED |
|------|------|---------|---------|
| 01   |      |         |         |
| ZONE |      |         |         |

|                                                                                                                                                                                                                             |       |                                                                                           |                       |      |  |
|-----------------------------------------------------------------------------------------------------------------------------------------------------------------------------------------------------------------------------|-------|-------------------------------------------------------------------------------------------|-----------------------|------|--|
|                                                                                                                                                                                                                             |       | <b>BHARAT HEAVY ELECTRICALS LTD</b><br>UNIT : BOILER AUXILIARIES PLANT<br>RANIPET-632 406 |                       |      |  |
| COPY RIGHT AND CONFIDENTIAL<br>The Information on this document is the property of<br>BHARAT HEAVY ELECTRICALS LIMITED it must not be used directly or<br>indirectly in any way detrimental to the interest of the company. |       |                                                                                           |                       |      |  |
| DEPT                                                                                                                                                                                                                        | DRN   | NAME                                                                                      | SIGN                  | DATE |  |
| CODE                                                                                                                                                                                                                        | DESN  | ACK                                                                                       |                       |      |  |
| 876                                                                                                                                                                                                                         | CHD   | RPS                                                                                       |                       |      |  |
|                                                                                                                                                                                                                             | APPD  | DNB                                                                                       |                       |      |  |
| TITLE<br><b>INSTRUMENT MOUNTING FRAME ARRANGEMENT (TYPICAL)</b>                                                                                                                                                             |       |                                                                                           |                       |      |  |
| DEPT.                                                                                                                                                                                                                       | SCALE | NTS                                                                                       | DRAWING NO.           |      |  |
|                                                                                                                                                                                                                             |       |                                                                                           | <b>3-WT-310-00019</b> |      |  |
| SIGN                                                                                                                                                                                                                        |       |                                                                                           | SHEET 1 OF 1          |      |  |
| DATE                                                                                                                                                                                                                        |       |                                                                                           | REV. 00               |      |  |

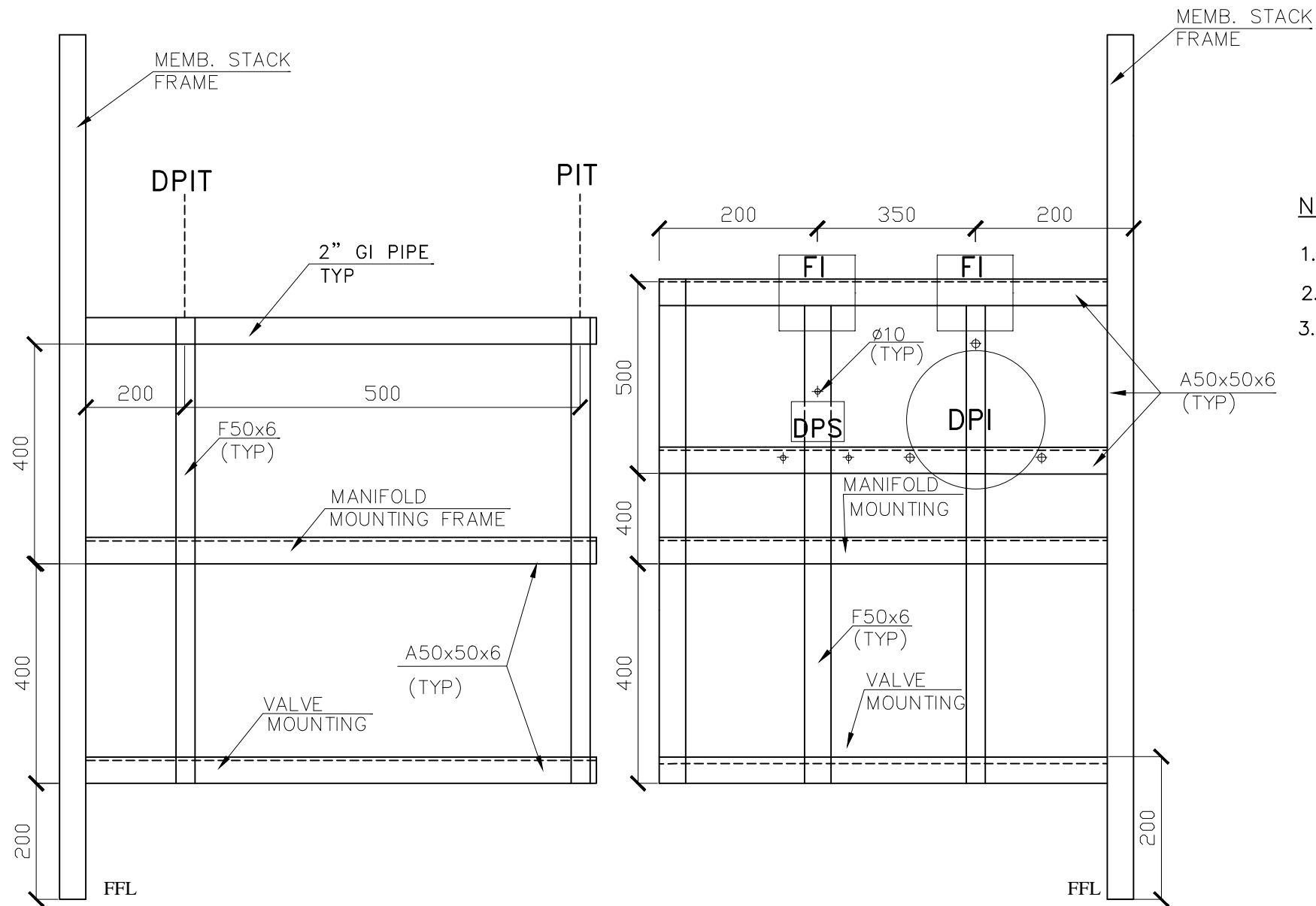

**NOTE: -**

1. THE FRAME SHALL BE FABRICATED AT SITE.
2. INSTRUMENT MOUNTING HOLE DIA IN THE FRAME SHALL BE  $\phi 10$ .
3. THE FRAME SHALL BE MOUNTED IN THE RO MEMB STACK FRAME.



**BHARAT HEAVY ELECTRICALS LTD**

UNIT : BOILER AUXILIARIES PLANT

RANIPET-632 406

|                                                                                                                                                                                                                             |  |  |  |  |              |             |             |      |      |
|-----------------------------------------------------------------------------------------------------------------------------------------------------------------------------------------------------------------------------|--|--|--|--|--------------|-------------|-------------|------|------|
| COPY RIGHT AND CONFIDENTIAL<br>The information on this document is the property of<br>BHARAT HEAVY ELECTRICALS LIMITED it Must not be used directly or<br>indirectly in any way detrimental to the interest of the company. |  |  |  |  | DEPT<br>CODE | DRN<br>DESN | NAME<br>ACK | SIGN | DATE |
|                                                                                                                                                                                                                             |  |  |  |  | 876          | CHD<br>APPD | RPS<br>DNB  |      |      |

| REV | DATE | ALTERED |
|-----|------|---------|
| 01  |      | CHECKED |

TITLE **INSTRUMENT MOUNTING FRAME ARRANGEMENT (TYPICAL)**

|      |  |
|------|--|
| ZONE |  |
|------|--|

|       |       |     |                       |
|-------|-------|-----|-----------------------|
| DEPT. | SCALE | NTS | DRAWING NO.           |
| SIGN  |       |     | <b>3-WT-310-00020</b> |
| DATE  |       |     | SHEET 1 OF 1 REV. 00  |

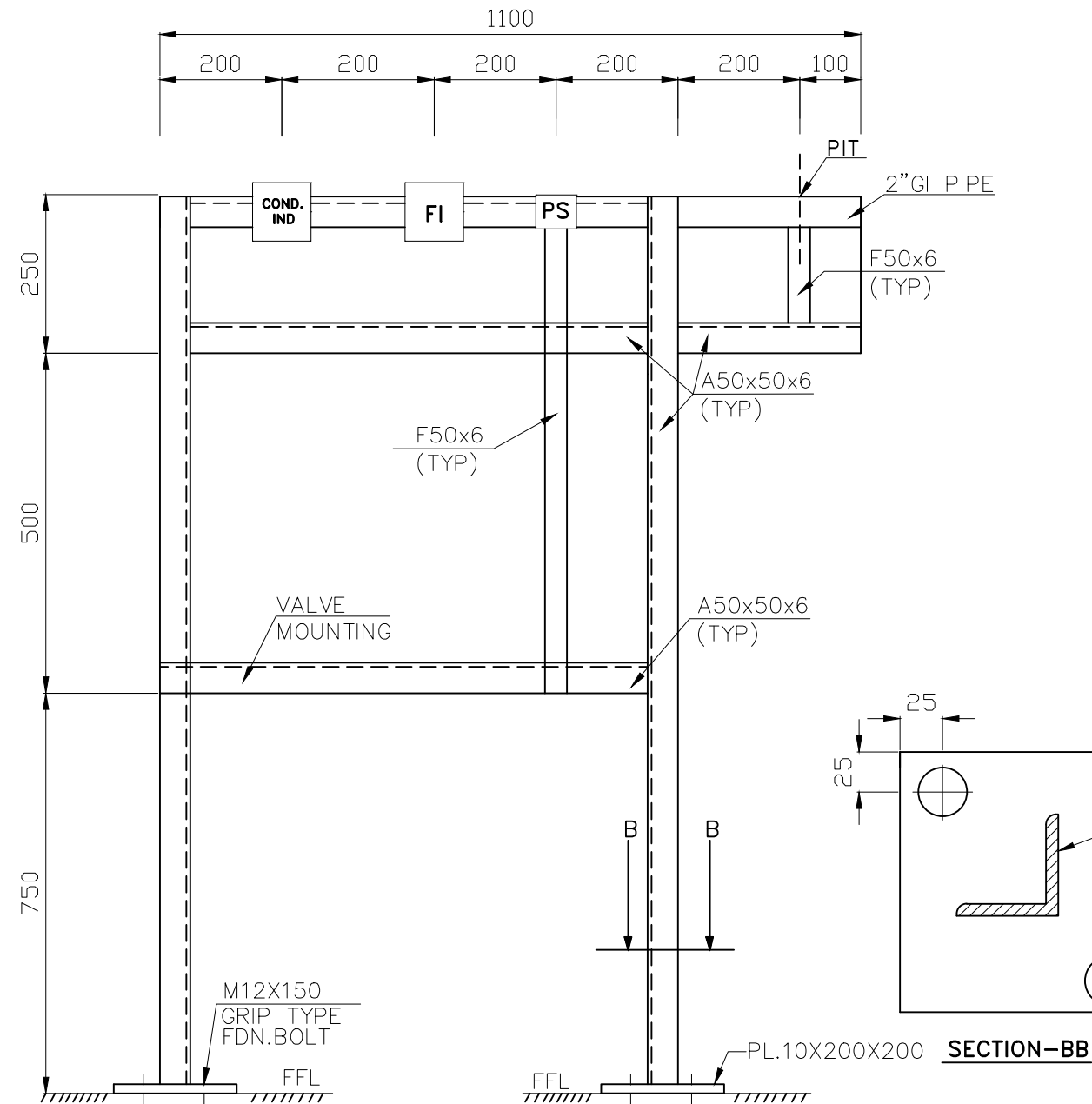

**NOTE: -**

1. THE FRAME SHALL BE FABRICATED AT SITE.
2. INSTRUMENT MOUNTING HOLE DIA IN THE FRAME SHALL BE  $\phi 10$ .

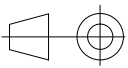
|                                                                                       |                                                                                                                                                                                                                       |                                                                                       |      |                       |  |
|---------------------------------------------------------------------------------------|-----------------------------------------------------------------------------------------------------------------------------------------------------------------------------------------------------------------------|---------------------------------------------------------------------------------------|------|-----------------------|--|
|  | <b>BHARAT HEAVY ELECTRICALS LTD</b><br>UNIT : BOILER AUXILIARIES PLANT<br>RANIPET-632 406                                                                                                                             |                                                                                       |      |                       |  |
|                                                                                       | COPY RIGHT AND CONFIDENTIAL<br>The information on this document is the property of BHARAT HEAVY ELECTRICALS LIMITED it Must not be used directly or indirectly in any way detrimental to the interest of the company. |                                                                                       |      |                       |  |
| DEPT CODE                                                                             | DRN                                                                                                                                                                                                                   | NAME ACK                                                                              | SIGN | DATE                  |  |
| 876                                                                                   | CHD                                                                                                                                                                                                                   | RPS                                                                                   |      |                       |  |
| APPD DNB                                                                              |                                                                                                                                                                                                                       |                                                                                       |      |                       |  |
| TITLE<br><b>INSTRUMENT MOUNTING FRAME ARRANGEMENT (TYPICAL)</b>                       |                                                                                                                                                                                                                       |                                                                                       |      |                       |  |
| DEPT.                                                                                 |                                                                                                                                                                                                                       | SCALE                                                                                 |      | DRAWING NO.           |  |
| SIGN                                                                                  |                                                                                                                                                                                                                       | NTS                                                                                   |      | <b>3-WT-310-00021</b> |  |
| DATE                                                                                  |                                                                                                                                                                                                                       |  |      | SHEET 1 OF 1 REV. 00  |  |

| REV  | DATE | ALTERED | CHECKED | DATE |
|------|------|---------|---------|------|
| 01   |      | CHECKED |         |      |
| ZONE |      |         |         |      |

MEMB.STACK  
FRAME

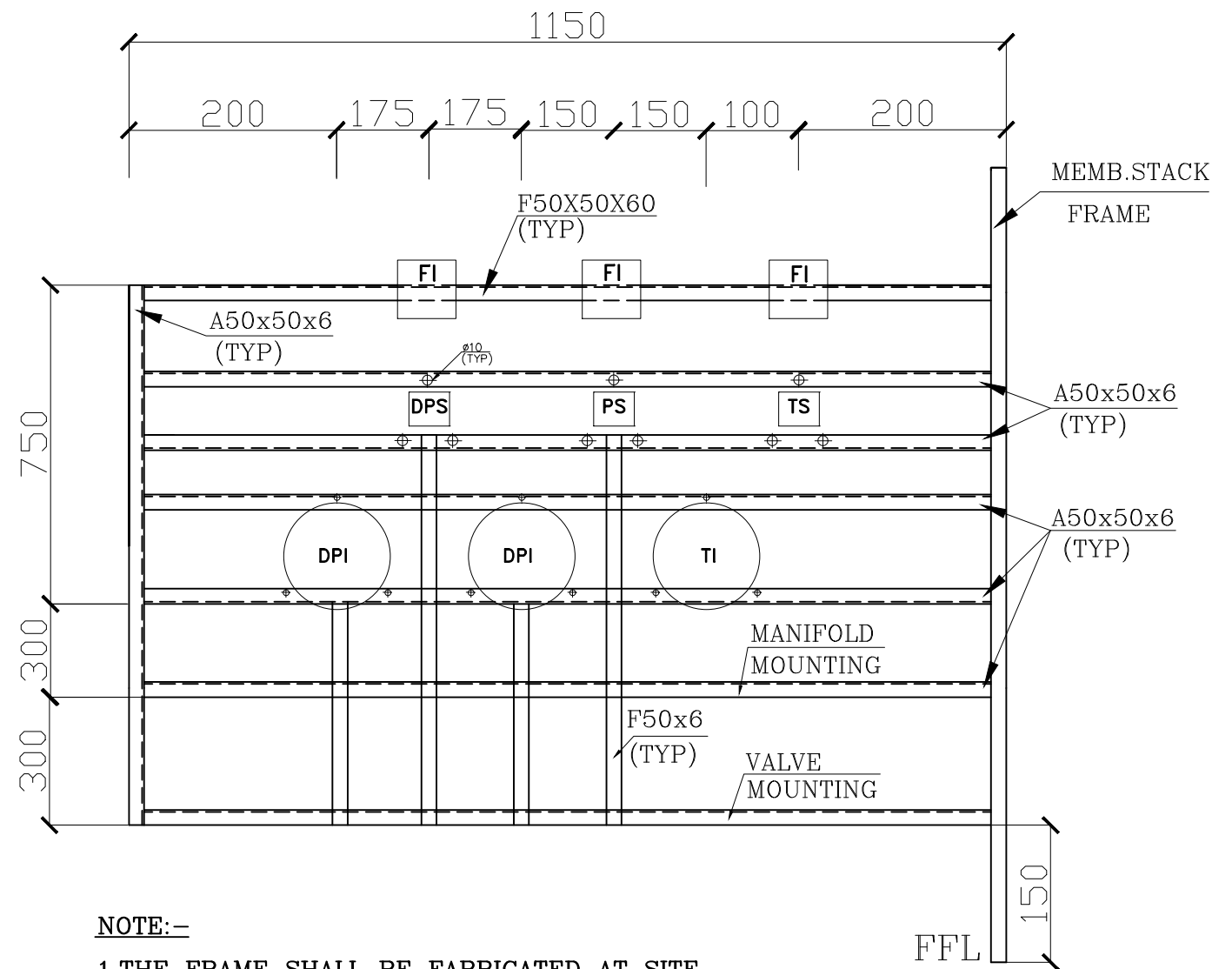
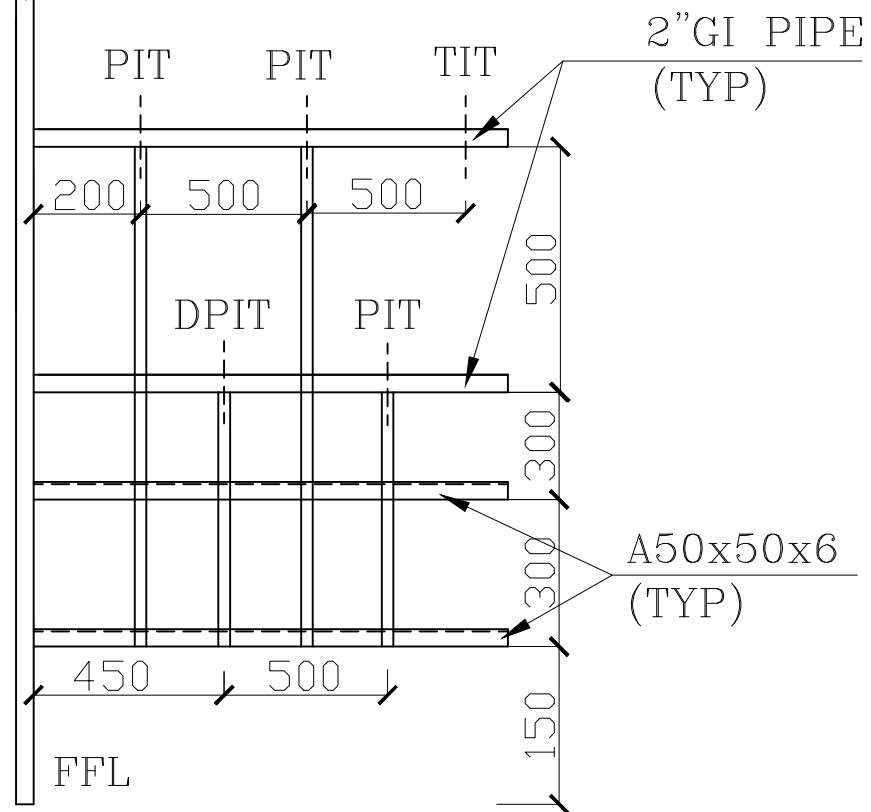

**NOTE:-**

- 1.THE FRAME SHALL BE FABRICATED AT SITE.
- 2.INSTRUMENT MOUNTING HOLE DIA IN THE FRAME SHALL BE ∅10.
- 3.THE FRAME SHALL BE MOUNTED IN THE RO MEMB STACK FRAME.

| REV  | DATE | ALTERED | CHECKED |
|------|------|---------|---------|
| 01   |      |         |         |
| ZONE |      |         |         |

|                                                                                                                                                                                        |       |         |                |                                     |     |      |      |
|----------------------------------------------------------------------------------------------------------------------------------------------------------------------------------------|-------|---------|----------------|-------------------------------------|-----|------|------|
|                                                                                                                                                                                        |       |         |                | <b>BHARAT HEAVY ELECTRICALS LTD</b> |     |      |      |
|                                                                                                                                                                                        |       |         |                | UNIT : BOILER AUXILIARIES PLANT     |     |      |      |
|                                                                                                                                                                                        |       |         |                | RANIPET-632 406                     |     |      |      |
| COPY RIGHT AND CONFIDENTIAL                                                                                                                                                            |       |         |                |                                     |     |      |      |
| The information on this document is the property of BHARAT HEAVY ELECTRICALS LIMITED it must not be used directly or indirectly in any way detrimental to the interest of the company. |       |         |                |                                     |     |      |      |
| DEPT                                                                                                                                                                                   | DRN   | NAME    | SIGN           | DATE                                | CHD | IRPS | APPD |
| 876                                                                                                                                                                                    |       |         |                |                                     |     |      |      |
| TITLE                                                                                                                                                                                  |       |         |                |                                     |     |      |      |
| INSTRUMENT MOUNTING FRAME ARRANGEMENT (TYPICAL)                                                                                                                                        |       |         |                |                                     |     |      |      |
| DEPT.                                                                                                                                                                                  | SCALE | NTB     | DRAWING NO.    |                                     |     |      |      |
|                                                                                                                                                                                        |       |         | 3-WT-310-00022 |                                     |     |      |      |
| SIGN                                                                                                                                                                                   | DATE  | SHEET 1 | OF 1           | REV.                                | 00  |      |      |

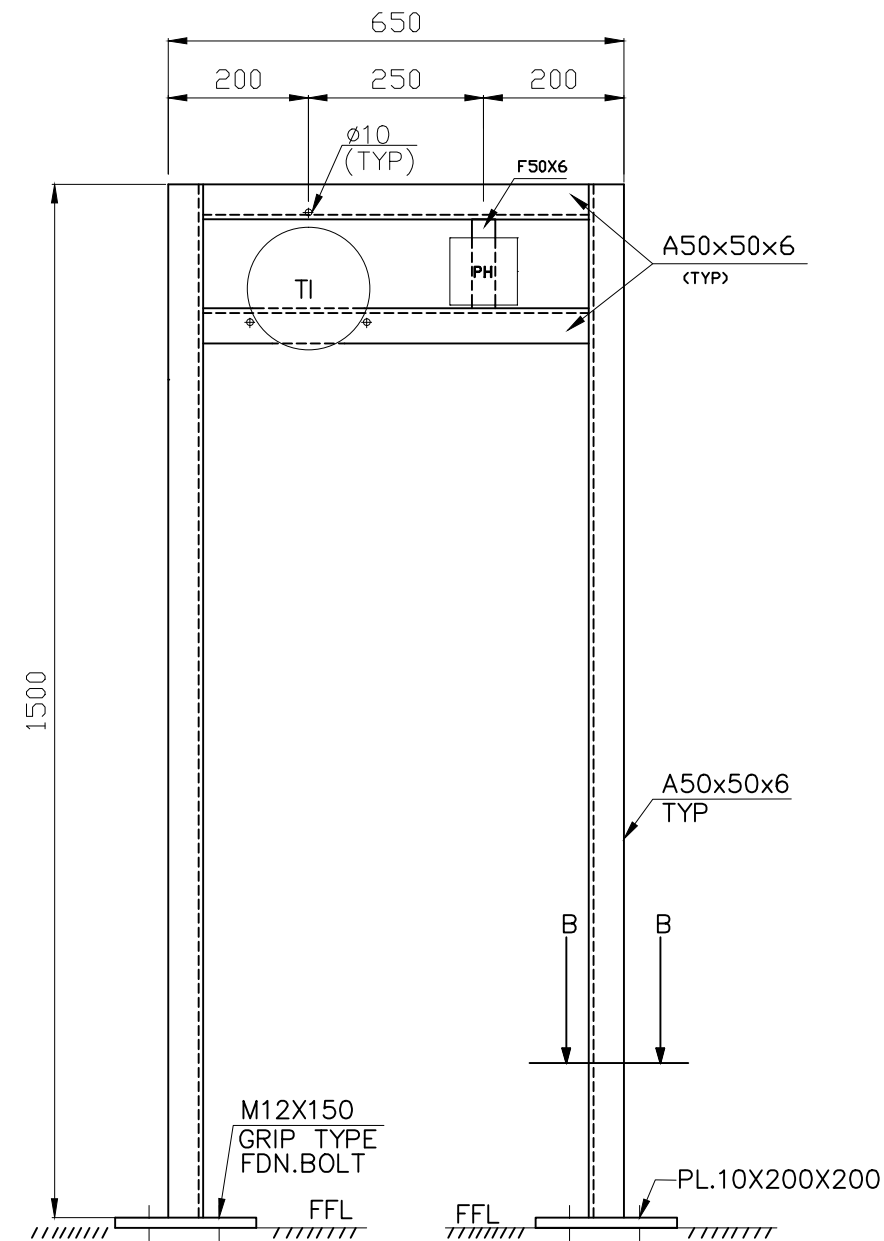

**NOTE: -**

1. THE FRAME SHALL BE FABRICATED AT SITE.
2. INSTRUMENT MOUNTING HOLE DIA IN THE FRAME SHALL BE  $\phi 10$ .

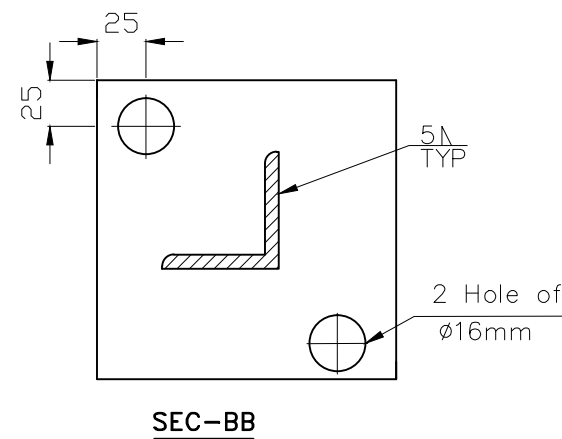

| REV  | DATE | ALTERED |  |
|------|------|---------|--|
| 01   |      | CHECKED |  |
| ZONE |      |         |  |

|                                                                                       |                                                                                                                                                                                                                             |             |                       |      |         |
|---------------------------------------------------------------------------------------|-----------------------------------------------------------------------------------------------------------------------------------------------------------------------------------------------------------------------------|-------------|-----------------------|------|---------|
|  | <b>BHARAT HEAVY ELECTRICALS LTD</b><br>UNIT : BOILER AUXILIARIES PLANT<br>RANIPET-632 406                                                                                                                                   |             |                       |      |         |
|                                                                                       | COPY RIGHT AND CONFIDENTIAL<br>The information on this document is the property of<br>BHARAT HEAVY ELECTRICALS LIMITED it Must not be used directly or<br>indirectly in any way detrimental to the interest of the company. |             |                       |      |         |
| DEPT<br>CODE                                                                          | DRN<br>DESN                                                                                                                                                                                                                 | NAME<br>ACK | SIGN                  | DATE |         |
| 876                                                                                   | CHD<br>APPD                                                                                                                                                                                                                 | RPS<br>DNB  |                       |      |         |
| TITLE<br><b>INSTRUMENT MOUNTING FRAME ARRANGEMENT (TYPICAL)</b>                       |                                                                                                                                                                                                                             |             |                       |      |         |
| DEPT.                                                                                 | SCALE                                                                                                                                                                                                                       | NTS         | DRAWING NO.           |      |         |
| SIGN                                                                                  |                                                                                                                                                                                                                             |             | <b>3-WT-310-00023</b> |      |         |
| DATE                                                                                  |                                                                                                                                                                                                                             |             | SHEET 1               | OF 1 | REV. 00 |

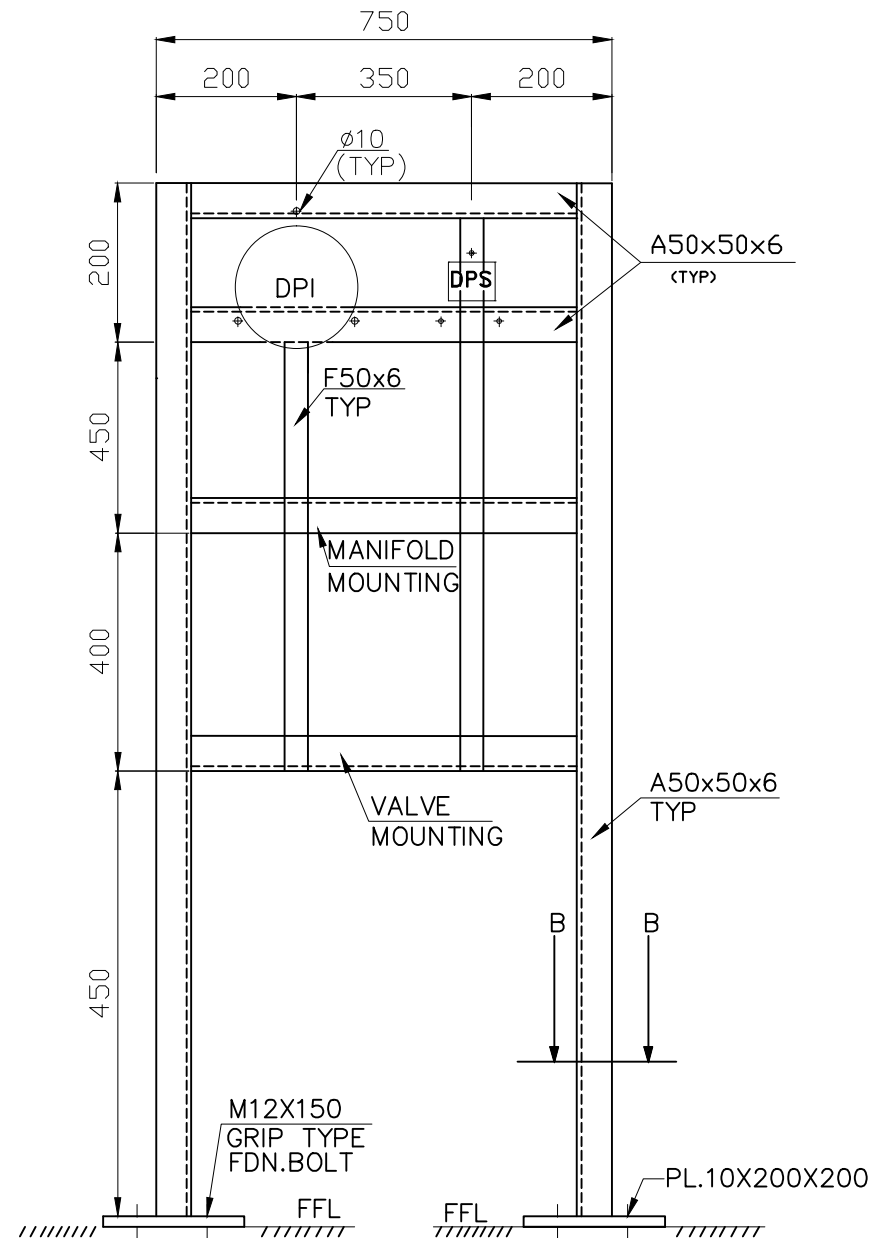

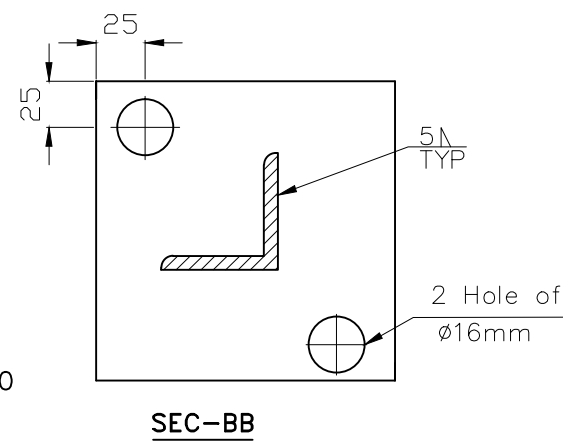

**NOTE: -**

1. THE FRAME SHALL BE FABRICATED AT SITE.
2. INSTRUMENT MOUNTING HOLE DIA IN THE FRAME SHALL BE  $\phi 10$ .



**SEC-BB**

|                                                                                       |                                                                                                                                                                                                                             |                                                                                       |                       |      |         |
|---------------------------------------------------------------------------------------|-----------------------------------------------------------------------------------------------------------------------------------------------------------------------------------------------------------------------------|---------------------------------------------------------------------------------------|-----------------------|------|---------|
|  | <b>BHARAT HEAVY ELECTRICALS LTD</b><br>UNIT : BOILER AUXILIARIES PLANT<br>RANIPET-632 406                                                                                                                                   |                                                                                       |                       |      |         |
|                                                                                       | COPY RIGHT AND CONFIDENTIAL<br>The information on this document is the property of<br>BHARAT HEAVY ELECTRICALS LIMITED it Must not be used directly or<br>indirectly in any way detrimental to the interest of the company. |                                                                                       |                       |      |         |
| DEPT<br>CODE                                                                          | DRN<br>DESN                                                                                                                                                                                                                 | NAME<br>ACK                                                                           | SIGN                  | DATE |         |
| 876                                                                                   | CHD<br>APPD                                                                                                                                                                                                                 | RPS<br>DNB                                                                            |                       |      |         |
| TITLE<br><b>INSTRUMENT MOUNTING FRAME ARRANGEMENT (TYPICAL)</b>                       |                                                                                                                                                                                                                             |                                                                                       |                       |      |         |
| DEPT.                                                                                 | SCALE                                                                                                                                                                                                                       | NTS                                                                                   | DRAWING NO.           |      |         |
| SIGN                                                                                  | DATE                                                                                                                                                                                                                        |  | <b>3-WT-310-00024</b> |      |         |
|                                                                                       |                                                                                                                                                                                                                             |                                                                                       | SHEET 1               | OF 1 | REV. 00 |

| REV  | DATE | ALTERED | CHECKED |
|------|------|---------|---------|
| 01   |      | CHECKED |         |
| ZONE |      |         |         |

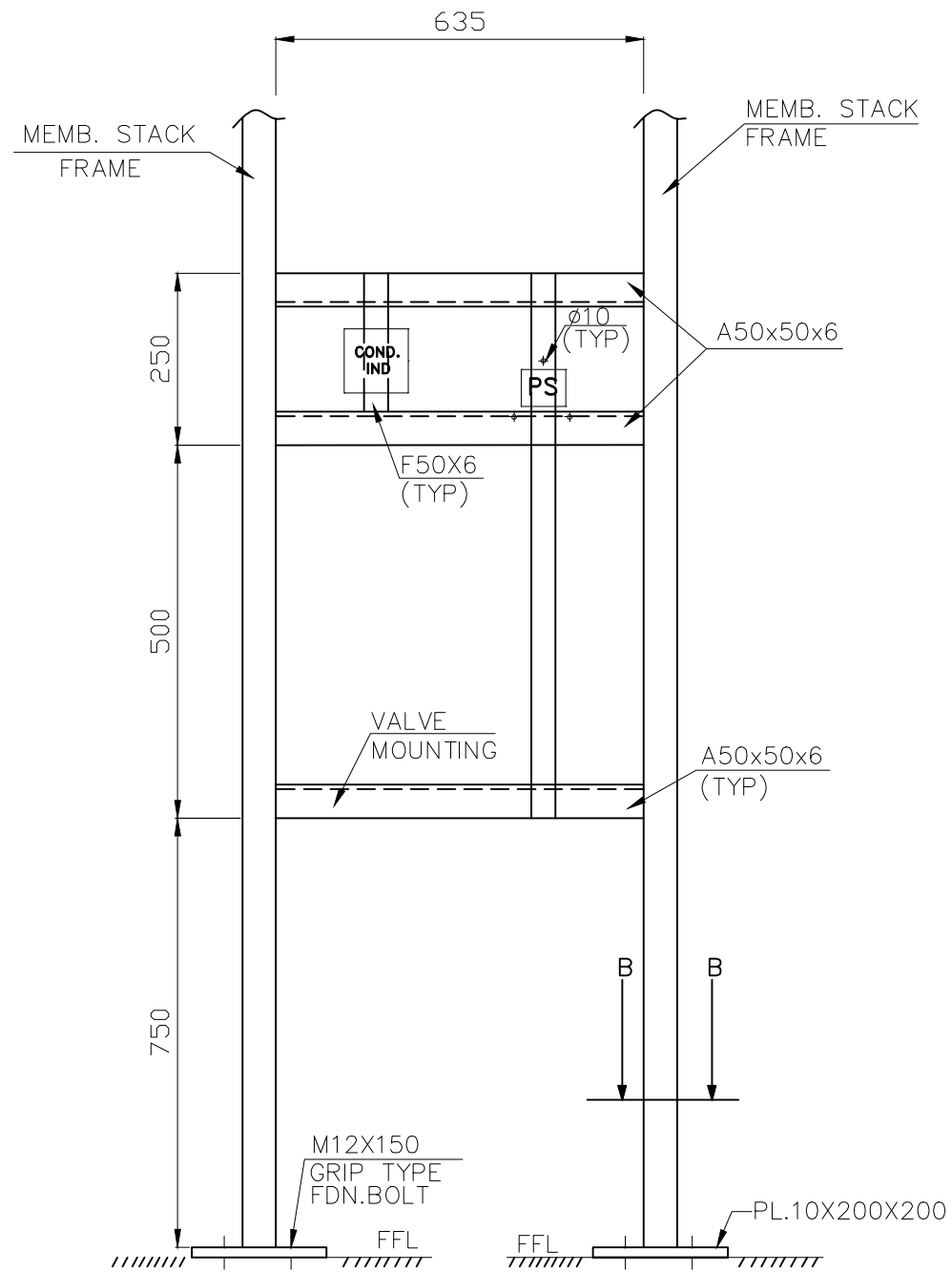

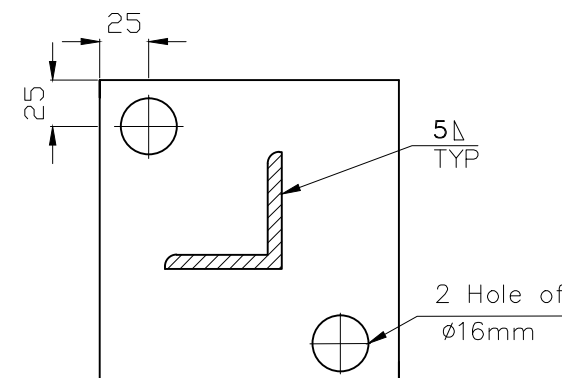

**NOTE: -**

1. THE FRAME SHALL BE FABRICATED AT SITE.
2. INSTRUMENT MOUNTING HOLE DIA IN THE FRAME SHALL BE  $\phi 10$ .
3. THE FRAME SHALL BE MOUNTED IN THE RO MEMB STACK FRAME.



**SECTION-BB**

|                                                                                       |                                                                                                                                                                                                                       |                                                                                       |                       |      |         |
|---------------------------------------------------------------------------------------|-----------------------------------------------------------------------------------------------------------------------------------------------------------------------------------------------------------------------|---------------------------------------------------------------------------------------|-----------------------|------|---------|
|  | <b>BHARAT HEAVY ELECTRICALS LTD</b><br>UNIT : BOILER AUXILIARIES PLANT<br>RANIPET-632 406                                                                                                                             |                                                                                       |                       |      |         |
|                                                                                       | COPY RIGHT AND CONFIDENTIAL<br>The information on this document is the property of BHARAT HEAVY ELECTRICALS LIMITED it Must not be used directly or indirectly in any way detrimental to the interest of the company. |                                                                                       |                       |      |         |
| DEPT CODE                                                                             | DRN                                                                                                                                                                                                                   | NAME ACK                                                                              | SIGN                  | DATE |         |
| 876                                                                                   | CHD                                                                                                                                                                                                                   | RPS                                                                                   |                       |      |         |
| APPD                                                                                  |                                                                                                                                                                                                                       |                                                                                       |                       |      | DNB     |
| TITLE<br><b>INSTRUMENT MOUNTING FRAME ARRANGEMENT (TYPICAL)</b>                       |                                                                                                                                                                                                                       |                                                                                       |                       |      |         |
| DEPT.                                                                                 | SCALE                                                                                                                                                                                                                 | NTS                                                                                   | DRAWING NO.           |      |         |
| SIGN                                                                                  | DATE                                                                                                                                                                                                                  |  | <b>3-WT-310-00025</b> |      |         |
|                                                                                       |                                                                                                                                                                                                                       |                                                                                       | SHEET 1               | OF 1 | REV. 00 |

| REV | DATE | ALTERED | ZONE |
|-----|------|---------|------|
| 01  |      | CHECKED |      |

FOR PRODUCTION  
 REF. PR:QA:590 FOR PAINTING  
 REF. PR:QA:500 FOR UNTOL. DIMNS.  
 REF. APPLICABLE GMS FOR MATCODE&SPEC.

PI-REMOTE MOUNTING

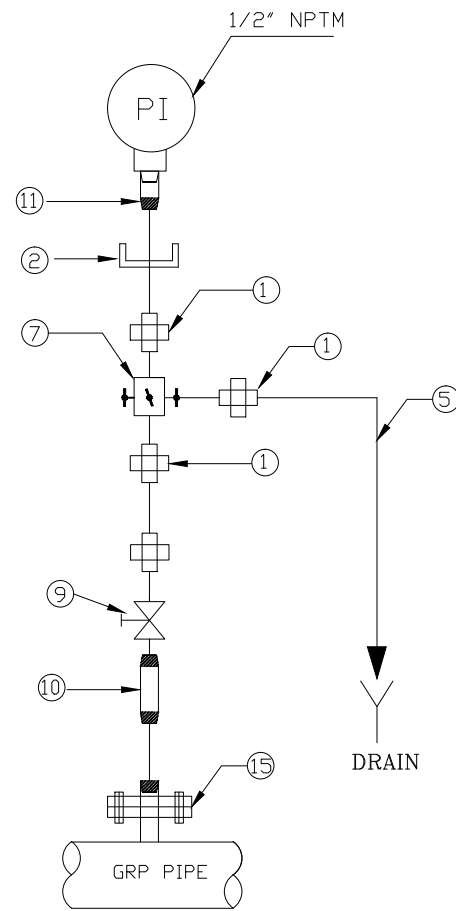

PI-DIRECT MOUNTING

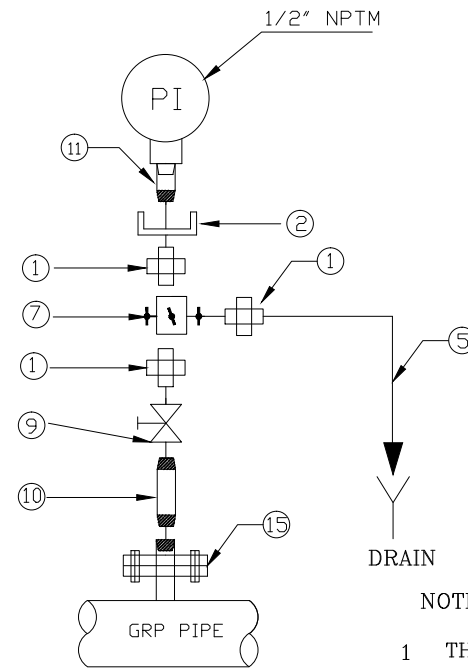

| SI. NO | ITEM. NO. | ITEM DESCRIPTION                                                                                                     | QUANTITY IN NOS |
|--------|-----------|----------------------------------------------------------------------------------------------------------------------|-----------------|
| 1      | 1         | 1/2" NPT SS316, double compression ferrule type male connector                                                       | 3               |
| 2      | 2         | 1/2" NPT SS316, double compression ferrule type female connector                                                     | 1               |
| 5      | 5         | 1/2" OD SS tube-5metres                                                                                              | 1               |
| 6      | 7         | 3 valve manifold                                                                                                     | 1               |
| 9      | 9         | 1/2" NB SS316 Ball Valve, 2 way with 1/2" NPT internal thread at both ends                                           | 1               |
| 10     | 10        | 1/2" NB pipe nipple                                                                                                  | 1               |
| 11     | 11        | 1/2" female NPT to male NPT adaptor                                                                                  | 1               |
| 12     | 15        | 1/2" NB Threaded flange with internal thread 1/2" NPT as per ANSI B16.5, 150 class with suitable gasket & fassteness | 1               |

NOTE:

- THIS INSTRUMENT SHALL BE MOUNTED ON A STEEL FRAME FABRICATED AT SITE AND MOUNTED NEAR BY STRUCTURE OR FIXED ON AN ANGLE IRON FRAME ON THE GROUND TO ENABLE EASY ACCESS TO THE OPERATOR FOR TAKING READINGS. THE TUBING IS TO BE SUITABLY ROUTED TO THE INSTRUMENT.
- REFER TO INSTALLATION INSTRUCTIONS DRG. NO: 4-WT-310-00017
- THE IMPULSE LINE SHALL BE ROUTED THROUGH PERFORATED CABLE TRAY WITH SUITABLE SUPPORTS.
- DRAIN LINE ARE TO BE CONNECTED IN THE DRAIN TRENCH

| SI. NO | ITEM. NO. | ITEM DESCRIPTION                                                                                                     | QUANTITY IN NOS |
|--------|-----------|----------------------------------------------------------------------------------------------------------------------|-----------------|
| 1      | 1         | 1/2" NPT SS316, double compression ferrule type male connector                                                       | 4               |
| 2      | 2         | 1/2" NPT SS316, double compression ferrule type female connector                                                     | 1               |
| 3      | 5         | 1/2" OD SS tube-10metres                                                                                             | 1               |
| 4      | 7         | 3 valve manifold                                                                                                     | 1               |
| 5      | 9         | 1/2" NB SS316 Ball Valve, 2 way with 1/2" NPT internal thread at both ends                                           | 1               |
| 6      | 10        | 1/2" NB pipe nipple                                                                                                  | 1               |
| 7      | 11        | 1/2" female NPT to male NPT adaptor                                                                                  | 1               |
| 8      | 15        | 1/2" NB Threaded flange with internal thread 1/2" NPT as per ANSI B16.5, 150 class with suitable gasket & fassteness | 1               |

| REV                    | DATE     | ALTERED | IRS |
|------------------------|----------|---------|-----|
| 01                     | 04.12.12 | CHECKED | RPS |
| ZONE NOTE 4 & 5 ADDED. |          |         |     |



**BHARAT HEAVY ELECTRICALS LTD**  
 UNIT : BOILER AUXILIARIES PLANT  
 RANIPET-632 406

COPY RIGHT AND CONFIDENTIAL  
 The inforMation on this docuMent is the property of BHARAT HEAVY ELECTRICALS LIMITED it Must not be used directly or indirectly in any way deteriMental to the interest of the coMpany.

| DEPT CODE | DRN  | NAME ACK | SIGN | DATE |
|-----------|------|----------|------|------|
| 876       | CHD  | RPS      |      |      |
|           | APPD | DNB      |      |      |

**TITLE PRESSURE INDICATOR INSTALLATION IN GRP LINE (TYPICAL)**

|       |       |     |                       |
|-------|-------|-----|-----------------------|
| DEPT. | SCALE | NTS | DRAWING NO.           |
| SIGN  |       |     | <b>3-WT-310-00026</b> |
| DATE  |       |     | SHEET 1 OF 1 REV. 01  |

3-WT-310-00027

DRAWING NO.

ALL DIMENSIONS ARE IN MILLIMETRES

FOR PRODUCTION  
 REF. PR:QA:590 FOR PAINTING  
 REF. PR:QA:500 FOR UNTOL. DIMNS.  
 REF. APPLICABLE GMS FOR MATCODE&SPEC.

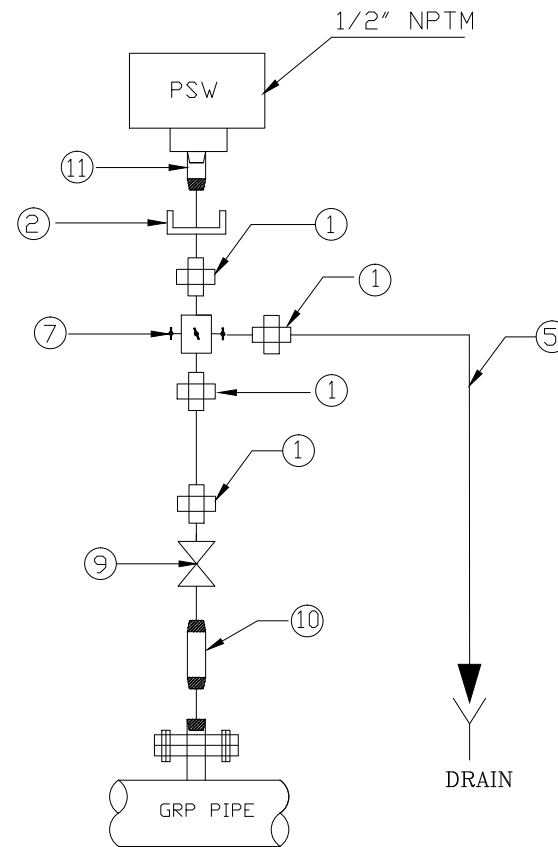

NOTE:

- 1 THIS INSTRUMENT SHALL BE MOUNTED ON A 2.5MM THICK MS SHEET WHICH SHALL BE WELDED TO A NEAR BY STRUCTURE OR FIXED ON AN ANGLE IRON FRAMEWORK GROUTED TO THE FLOOR. THE MS SHEET HAS TO BE EPOXY PAINTED IN LIGHT GREY COLOUR.
- 2 THIS INSTRUMENT SHALL BE LOCATED AT A SUITABLE LOCATION ON THE GROUND TO ENABLE EASY ACCESS TO THE OPERATOR FOR TAKING READINGS. THE TUBING IS TO BE SUITABLY ROUTED TO THE INSTRUMENT.
- 3 REFER TO INSTALLATION INSTRUCTIONS DRG. NO: 4-WT-310-00017
- 4 THE IMPULSE LINE SHALL BE ROUTED THROUGH PERFORATED CABLE TRAY WITH SUITABLE SUPPORTS.
- 5 DRAIN LINE ARE TO BE CONNECTED IN THE DRAIN TRENCH

| SI. NO | ITEM. NO. | ITEM DESCRIPTION                                                           | QUANTITY IN NOS |
|--------|-----------|----------------------------------------------------------------------------|-----------------|
| 1      | 1         | 1/2" NPT SS316, double compression ferrule type male connector             | 4               |
| 2      | 2         | 1/2" NPT SS316, double compression ferrule type female connector           | 1               |
| 3      | 5         | 1/2" OD SS tube-10metres                                                   | 1               |
| 4      | 7         | 3 valve manifold                                                           | 1               |
| 5      | 9         | 1/2" NB SS316 Ball Valve, 2 way with 1/2" NPT internal thread at both ends | 1               |
| 6      | 10        | 1/2" NB pipe nipple                                                        | 1               |
| 7      | 11        | 1/2" female NPT to male NPT adaptor                                        | 1               |

| REV  | DATE     | ALTERED          | IRS |
|------|----------|------------------|-----|
| 01   | 04.12.12 | CHECKED          | RPS |
| ZONE |          | NOTE 4 & 5 ADDED |     |

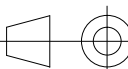
|                                                                                                                        |                                                                                                                                                                                                                       |                                                                                            |                                      |                                                    |
|------------------------------------------------------------------------------------------------------------------------|-----------------------------------------------------------------------------------------------------------------------------------------------------------------------------------------------------------------------|--------------------------------------------------------------------------------------------|--------------------------------------|----------------------------------------------------|
|                                   | BHARAT HEAVY ELECTRICALS LTD<br>UNIT : BOILER AUXILIARIES PLANT<br>RANIPET-632 406                                                                                                                                    |                                                                                            |                                      |                                                    |
|                                                                                                                        | COPY RIGHT AND CONFIDENTIAL<br>The information on this document is the property of BHARAT HEAVY ELECTRICALS LIMITED it must not be used directly or indirectly in any way detrimental to the interest of the company. |                                                                                            | DEPT CODE<br>876                     | NAME<br>DRN ACK<br>DESN ACK<br>CHD RPS<br>APPD DNB |
| TITLE <b>PRESSURE INDICATING TRANSMITTER / PRESSURE SWITCH<br/>                 INSTALLATION IN GRP LINE (TYPICAL)</b> |                                                                                                                                                                                                                       |                                                                                            |                                      |                                                    |
|                                                                                                                        |                                                                                                                                                                                                                       | DEPT. SCALE <b>NTS</b>                                                                     | DRAWING NO.<br><b>3-WT-310-00027</b> |                                                    |
|                                                                                                                        |                                                                                                                                                                                                                       | SIGN  | SHEET 1 OF 1 REV. 01                 |                                                    |

82000-01E-LM-E

DRAWING NO.

ALL DIMENSIONS ARE IN MILLIMETRES  
 FOR PRODUCTION  
 REF. PR:QA:590 FOR PAINTING  
 REF. PR:QA:500 FOR UNTOL. DIMNS.  
 REF. APPLICABLE GMS FOR MATCODE&SPEC.

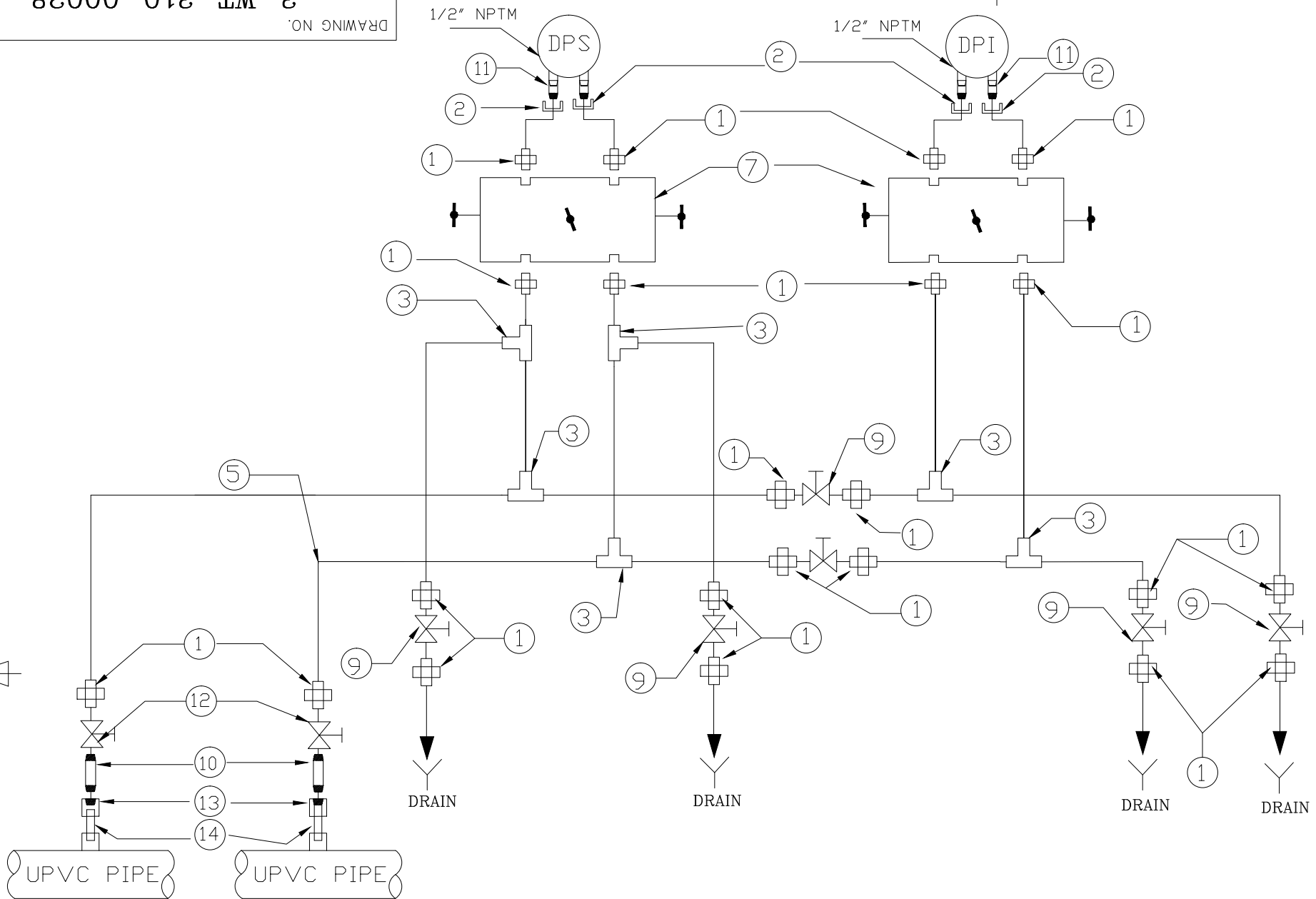

| SI. NO | ITEM. NO. | ITEM DESCRIPTION                                                           | QUANTITY IN NOS |
|--------|-----------|----------------------------------------------------------------------------|-----------------|
| 1      | 1         | 1/2" NPT SS316, double compression ferrule type male connector             | 22              |
| 2      | 2         | 1/2" NPT SS316, double ompression ferrule type female connector            | 4               |
| 3      | 3         | Equal Tee                                                                  | 6               |
| 4      | 5         | 1/2" OD SS tube-20metres                                                   | 1               |
| 5      | 7         | 3 valve manifold                                                           | 2               |
| 6      | 9         | 1/2" NB SS316 Ball Valve, 2 way with 1/2" NPT internal thread at both ends | 6               |
| 7      | 10        | 1/2" NB pipe nipple                                                        | 2               |
| 8      | 11        | 1/2" female NPT to male NPT adaptor                                        | 4               |
| 9      | 12        | 1/2" UPVC 2 way ball valve                                                 | 2               |
| 10     | 13        | 1/2" OD UPVC PIPE-70mm                                                     | 2               |
| 11     | 14        | 1/2" NPT Female Socket Adaptor                                             | 2               |

NOTE:

- THIS INSTRUMENT SHALL BE MOUNTED ON A FRAME WHICH SHALL BE WELDED TO A NEAR BY STRUCTURE OR FIXED ON AN ANGLE IRON FRAMEWORK GROUTED TO THE FLOOR. THE FRAME HAS TO BE EPOXY PAINTED IN LIGHT GREY COLOUR.
- THIS INSTRUMENT & 3 VALVE MANIFOLD SHALL BE LOCATED AT A SUITABLE LOCATION ON THE GROUND TO ENABLE EASY ACCESS TO THE OPERATOR FOR TAKING READINGS. THE TUBING IS TO BE SUITABLY ROUTED TO THE INSTRUMENT.
- REFER TO INSTALLATION INSTRUCTIONS DRG. NO: 4-WT-310-00017
- THE IMPULSE LINE SHALL BE ROUTED THROUGH PERFORATED CABLE TRAY WITH SUITABLE SUPPORTS.
- DRAIN LINE ARE TO BE CONNECTED IN THE DRAIN TRENCH

| REV | DATE     | ALTERED | IRS |
|-----|----------|---------|-----|
| 01  | 04.12.12 | CHECKED | RPS |

ZONE NOTE 4 & 5 ADDED



बीएचईल  
BHEL

BHARAT HEAVY ELECTRICALS LTD  
 UNIT : BOILER AUXILIARIES PLANT  
 RANIPET-632 406

COPY RIGHT AND CONFIDENTIAL  
 The information on this document is the property of BHARAT HEAVY ELECTRICALS LIMITED it must not be used directly or indirectly in any way detrimental to the interest of the company.

| DEPT CODE | DRN  | NAME | SIGN | DATE |
|-----------|------|------|------|------|
|           | 876  | ACK  |      |      |
|           | DESN | ACK  |      |      |
|           | CHD  | RPS  |      |      |
|           | APPD | DNB  |      |      |

**TITLE** DIFFERENT PRESSURE GAUGE / SWITCH INSTALLATION  
 IN LOW PRESSURE LINE (LP) (TYPICAL)

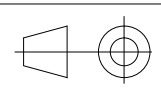
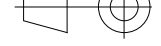
|  |  |  |  |  |  |  |  |       |                                                                                       |     |                       |
|--|--|--|--|--|--|--|--|-------|---------------------------------------------------------------------------------------|-----|-----------------------|
|  |  |  |  |  |  |  |  |       |                                                                                       |     |                       |
|  |  |  |  |  |  |  |  | DEPT. | SCALE                                                                                 | NTS | DRAWING NO.           |
|  |  |  |  |  |  |  |  | SIGN  |  |     | <b>3-WT-310-00028</b> |
|  |  |  |  |  |  |  |  | DATE  |  |     | SHEET 1 OF 1 REV. 01  |

3-WT-310-00029

DRAWING NO.

ALL DIMENSIONS ARE IN MILLIMETRES  
 FOR PRODUCTION  
 REF. PR:QA:590 FOR PAINTING  
 REF. PR:QA:500 FOR UNTOL. DIMNS.  
 REF. APPLICABLE GMS FOR MATCODE&SPEC.

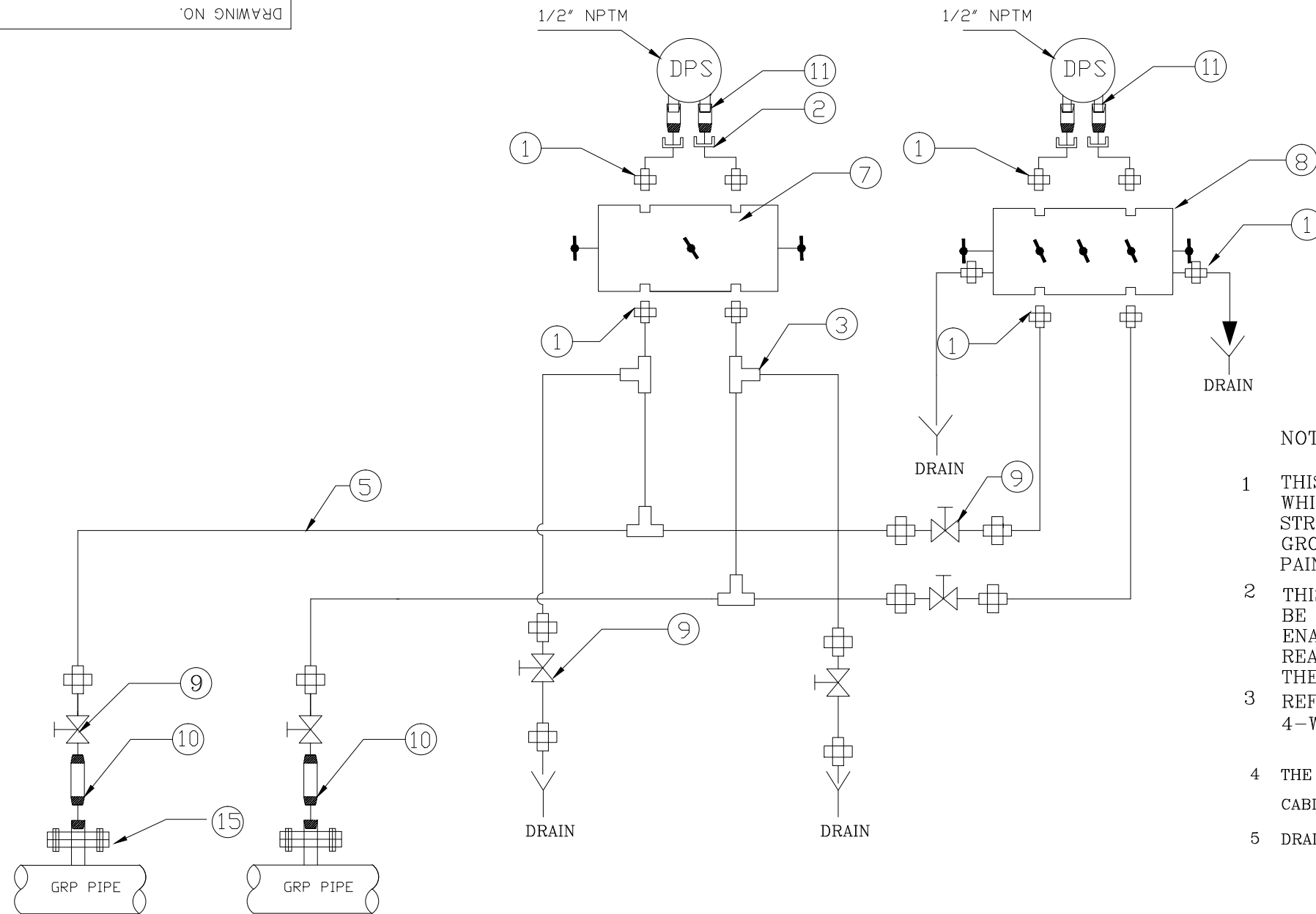

NOTE:

- 1 THIS INSTRUMENT SHALL BE MOUNTED ON A FRAME WHICH SHALL BE WELDED TO A NEAR BY STRUCTURE OR FIXED ON AN ANGLE IRON FRAMEWORK GROUTED TO THE FLOOR. THE FRAME HAS TO BE EPOXY PAINTED IN LIGHT GREY COLOUR.
- 2 THIS INSTRUMENT & 3 VALVE/ 5 VALVE MANIFOLD SHALL BE LOCATED AT A SUITABLE LOCATION IN THE GROUND TO ENABLE EASY ACCESS TO THE OPERATOR FOR TAKING READINGS. THE TUBING IS TO BE SUITABLY ROUTED TO THE INSTRUMENT.
- 3 REFER TO INSTALLATION INSTRUCTIONS DRG. NO: 4-WT-310-00017
- 4 THE IMPULSE LINE SHALL BE ROUTED THROUGH PERFORATED CABLE TRAY WITH SUITABLE SUPPORTS.
- 5 DRAIN LINE ARE TO BE CONNECTED IN THE DRAIN TRENCH

| SI. NO | ITEM. NO. | ITEM DESCRIPTION                                                                                                    | QUANTITY IN NOS |
|--------|-----------|---------------------------------------------------------------------------------------------------------------------|-----------------|
| 1      | 1         | 1/2" NPT SS316,double compression ferrule type male connector                                                       | 20              |
| 2      | 2         | 1/2" NPT SS316,double ompression ferrule type female connector                                                      | 4               |
| 3      | 3         | Equal Tee                                                                                                           | 4               |
| 5      | 5         | 1/2" OD SS tube-20metres                                                                                            | 1               |
| 7      | 7         | 3 valve manifold                                                                                                    | 1               |
| 8      | 8         | 5 valve manifold                                                                                                    | 1               |
| 9      | 9         | 1/2" NB SS316 Ball Valve,2 way with 1/2" NPT internal thread at both ends                                           | 6               |
| 10     | 10        | 1/2" NB pipe nipple                                                                                                 | 2               |
| 11     | 11        | 1/2" female NPT to male NPT adaptor                                                                                 | 4               |
| 12     | 15        | 1/2" NB Threaded flange with internal thread 1/2" NPT as per ANSI B16.5, 150 class with suitable gasket & fasstness | 1               |

| REV                   | DATE     | ALTERED | IRS |
|-----------------------|----------|---------|-----|
| 01                    | 04.12.12 | CHECKED | RPS |
| ZONE NOTE 4 & 5 ADDED |          |         |     |



**BHARAT HEAVY ELECTRICALS LTD**  
 UNIT : BOILER AUXILIARIES PLANT  
 RANIPET-632 406

COPY RIGHT AND CONFIDENTIAL  
 The information on this document is the property of BHARAT HEAVY ELECTRICALS LIMITED it must not be used directly or indirectly in any way detrimental to the interest of the company.

| DEPT CODE | DRN  | NAME | SIGN | DATE |
|-----------|------|------|------|------|
| 876       | ACK  |      |      |      |
|           | DESN | ACK  |      |      |
|           | CHD  | RPS  |      |      |
|           | APPD | DNB  |      |      |

**TITLE DP INDICATING TRANSMITTER/ DP SWITCH INSTALLATION IN GRP LINE (TYPICAL)**

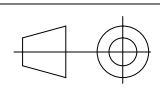
|       |                                                                                       |              |                       |
|-------|---------------------------------------------------------------------------------------|--------------|-----------------------|
| DEPT. | SCALE                                                                                 | NTS          | DRAWING NO.           |
| SIGN  |  |              | <b>3-WT-310-00029</b> |
| DATE  |                                                                                       | SHEET 1 OF 1 | REV. 01               |

03000-013-LM-3  
DRAWING NO.

ALL DIMENSIONS ARE IN MILLIMETRES

FOR PRODUCTION  
REF. PR:QA:590 FOR PAINTING  
REF. PR:QA:500 FOR UNTOL. DIMNS.  
REF. APPLICABLE GMS FOR MATCODE&SPEC.

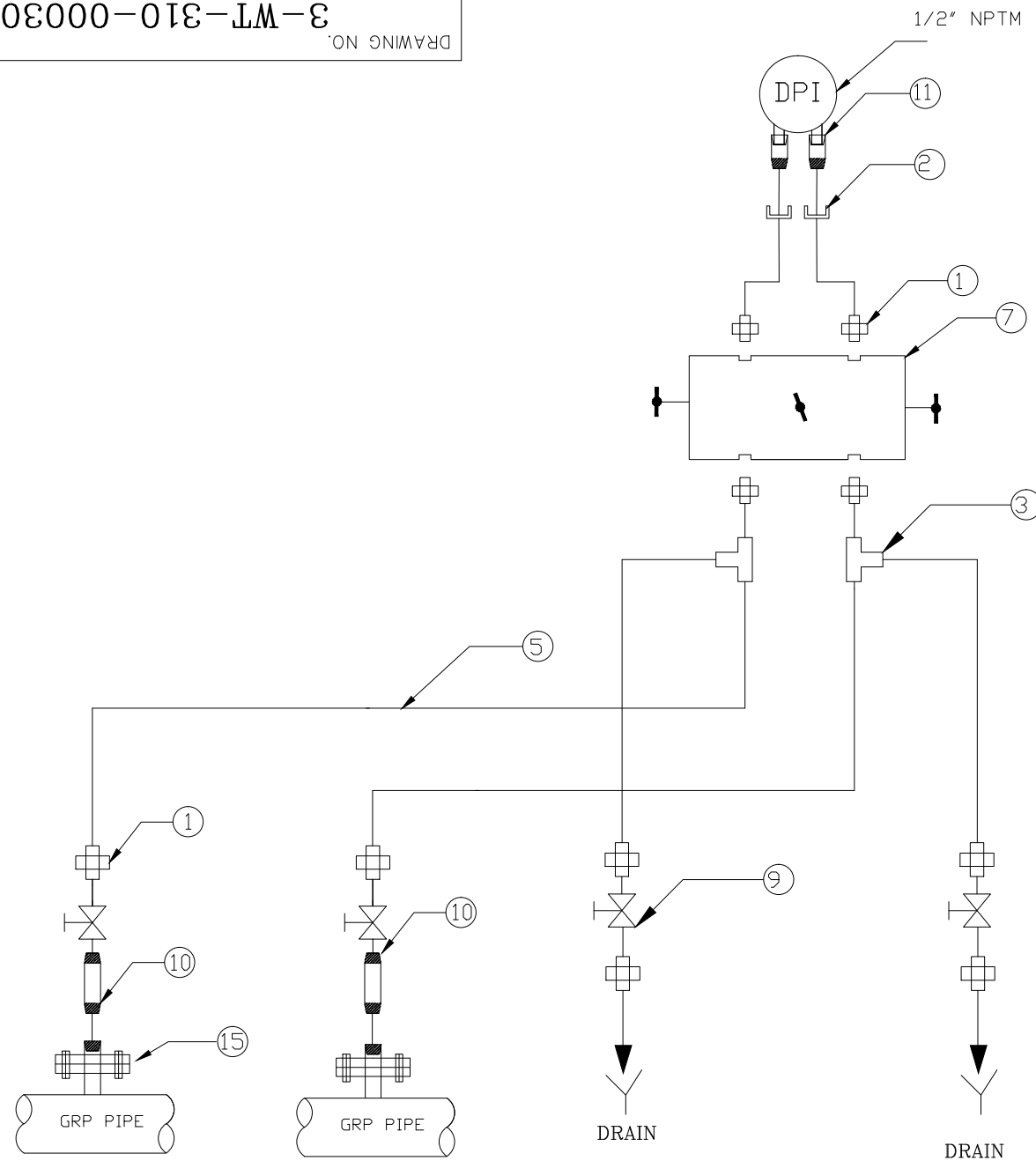

NOTES:

- 1 THIS INSTRUMENT SHALL BE MOUNTED ON A FRAME WHICH SHALL BE WELDED TO A NEAR BY STRUCTURE OR FIXED ON AN ANGLE IRON FRAME WORK GROUDED TO THE FLOOR. THE FRAME HAS TO BE EPOXY PAINTED IN LIGHT GREY COLOUR.
- 2 THIS INSTRUMENT & 3 VALVE MANIFOLD SHALL BE LOCATED AT A SUITABLE LOCATION ON THE GROUND TO ENABLE EASY ACCESS TO THE OPERATOR FOR TAKING READINGS. THE TUBING IS TO BE SUITABLY ROUTED TO THE INSTRUMENT.
- 3 REFER TO INSTALLATION INSTRUCTIONS DRG. NO: 4-WT-310-00017
- 4 THE IMPULSE LINE SHALL BE ROUTED THROUGH PERFORATED CABLE TRAY WITH SUITABLE SUPPORTS.
- 5 DRAIN LINE ARE TO BE CONNECTED IN THE DRAIN TRENCH

| SI. NO | ITEM .NO. | ITEM DESCRIPTION                                                                                                     | QUANTITY IN NOS |
|--------|-----------|----------------------------------------------------------------------------------------------------------------------|-----------------|
| 1      | 1         | 1/2" NPT SS316, double compression ferrule type male connector                                                       | 10              |
| 2      | 2         | 1/2" NPT SS316, double ompression ferrule type female connector                                                      | 2               |
| 3      | 3         | Equal Tee                                                                                                            | 2               |
| 4      | 5         | 1/2" OD SS tube-10metres                                                                                             | 1               |
| 5      | 7         | 3 valve manifold                                                                                                     | 1               |
| 6      | 9         | 1/2" NB SS316 Ball Valve, 2 way with 1/2" NPT internal thread at both ends                                           | 4               |
| 7      | 10        | 1/2" NB pipe nipple                                                                                                  | 2               |
| 8      | 11        | 1/2" female NPT to male NPT adaptor                                                                                  | 2               |
| 9      | 15        | 1/2" NB Threaded flange with internal thread 1/2" NPT as per ANSI B16.5, 150 class with suitable gasket & fassteness | 1               |

| REV  | DATE     | ALTERED          | IRS |
|------|----------|------------------|-----|
| 01   | 04.12.12 | CHECKED          | RPS |
| ZONE | ZONE     | NOTE 4 & 5 ADDED |     |

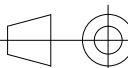
|                                                                                       |                                                                                                                                                                                                                       |          |                       |         |
|---------------------------------------------------------------------------------------|-----------------------------------------------------------------------------------------------------------------------------------------------------------------------------------------------------------------------|----------|-----------------------|---------|
|  | BHARAT HEAVY ELECTRICALS LTD<br>UNIT : BOILER AUXILIARIES PLANT<br>RANIPET-632 406                                                                                                                                    |          |                       |         |
|                                                                                       | COPY RIGHT AND CONFIDENTIAL<br>The information on this document is the property of BHARAT HEAVY ELECTRICALS LIMITED it must not be used directly or indirectly in any way detrimental to the interest of the company. |          |                       |         |
| DEPT CODE                                                                             | DRN                                                                                                                                                                                                                   | NAME ACK | SIGN                  | DATE    |
| 876                                                                                   | CHD                                                                                                                                                                                                                   | RPS      |                       |         |
|                                                                                       | APPD                                                                                                                                                                                                                  | DNB      |                       |         |
| TITLE <b>DIFFERENT PRESSURE GAUGE INSTALLATION IN GRP LINE (TYPICAL)</b>              |                                                                                                                                                                                                                       |          |                       |         |
| DEPT.                                                                                 | SCALE                                                                                                                                                                                                                 | NTS      | DRAWING NO.           |         |
| SIGN                                                                                  |                                                                                                                                  |          | <b>3-WT-310-00030</b> |         |
| DATE                                                                                  |                                                                                                                                                                                                                       |          | SHEET 1 OF 1          | REV. 01 |

3-WT-310-00031

DRAWING NO.

ALL DIMENSIONS ARE IN MILLIMETRES

FOR PRODUCTION  
 REF. PR:QA:590 FOR PAINTING  
 REF. PR:QA:500 FOR UNTOL. DIMNS.  
 REF. APPLICABLE GMS FOR MATCODE&SPEC.

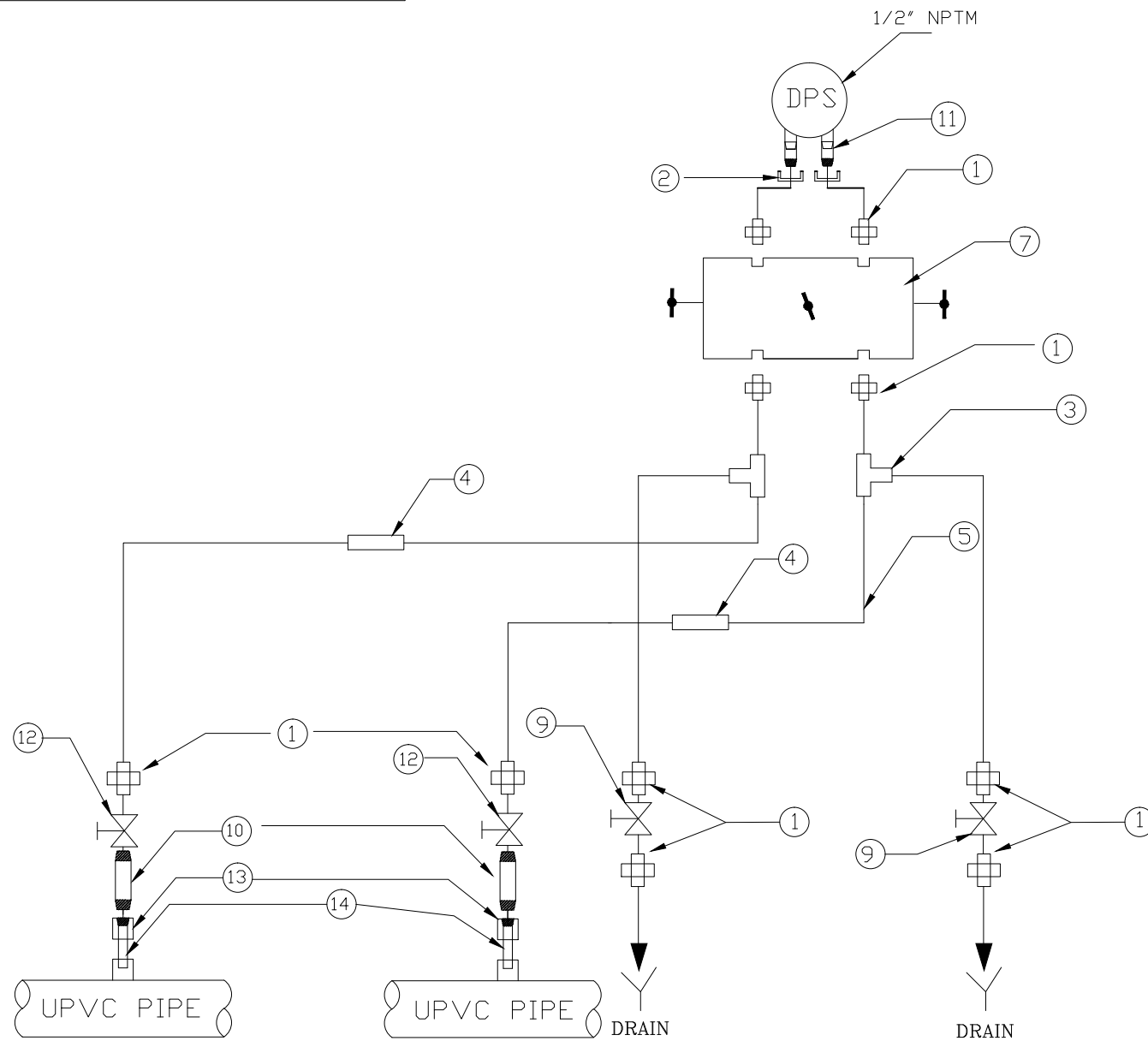

NOTE:

- 1 THIS INSTRUMENT SHALL BE MOUNTED ON A FRAME WHICH SHALL BE WELDED TO A NEAR BY STRUCTURE OR FIXED ON AN ANGLE IRON FRAME WORK GROUDED TO THE FLOOR. THE FRAME HAS TO BE EPOXY PAINTED IN LIGHT GREY COLOUR.
- 2 THIS INSTRUMENT & 3 VALVE MANIFOLD SHALL BE LOCATED AT A SUITABLE LOCATION ON THE GROUND TO ENABLE EASY ACCESS TO THE OPERATOR FOR TAKING READINGS. THE TUBING IS TO BE SUITABLY ROUTED TO THE INSTRUMENT.
- 3 REFER TO INSTALLATION INSTRUCTIONS DRG. NO: 4-WT-310-00017
- 4 THE IMPULSE LINE SHALL BE ROUTED THROUGH PERFORATED CABLE TRAY WITH SUITABLE SUPPORTS.
- 5 DRAIN LINE ARE TO BE CONNECTED IN THE DRAIN TRENCH

| SI. NO. | ITEM.NO | ITEM DESCRIPTION                                                          | QUANTIT Y IN NOS |
|---------|---------|---------------------------------------------------------------------------|------------------|
| 1       | 1       | 1/2" NPT SS316,double compression ferrule type male connector             | 10               |
| 2       | 2       | 1/2" NPT SS316,double compression ferrule type female connector           | 2                |
| 3       | 3       | Equal Tee                                                                 | 2                |
| 4       | 4       | Male Union                                                                | 2                |
| 5       | 5       | 1/2" OD SS tube-10metres                                                  | 1                |
| 6       | 7       | 3 valve manifold                                                          | 1                |
| 7       | 9       | 1/2" NB SS316 Ball Valve,2 way with 1/2" NPT internal thread at both ends | 2                |
| 8       | 10      | 1/2" NB pipe nipple                                                       | 2                |
| 9       | 11      | 1/2" female NPT to male NPT adaptor                                       | 2                |

| REV                   | DATE     | ALTERED | IRS |
|-----------------------|----------|---------|-----|
| 01                    | 04.12.12 | CHECKED | RPS |
| ZONE NOTE 4 & 5 ADDED |          |         |     |



BHARAT HEAVY ELECTRICALS LTD  
 UNIT : BOILER AUXILIARIES PLANT  
 RANIPET-632 406

|                                                                                                                                                                                                                       |      |          |      |      |
|-----------------------------------------------------------------------------------------------------------------------------------------------------------------------------------------------------------------------|------|----------|------|------|
| COPY RIGHT AND CONFIDENTIAL<br>The information on this document is the property of BHARAT HEAVY ELECTRICALS LIMITED it must not be used directly or indirectly in any way detrimental to the interest of the company. |      |          |      |      |
| DEPT CODE                                                                                                                                                                                                             | DRN  | NAME ACK | SIGN | DATE |
| 876                                                                                                                                                                                                                   | CHD  | RPS      |      |      |
|                                                                                                                                                                                                                       | APPD | DNB      |      |      |

TITLE **DIFFERENT PRESSURE SWITCH INSTALLATION IN LOW PRESSURE LINE (LP) (TYPICAL)**

|       |       |     |                       |
|-------|-------|-----|-----------------------|
| DEPT. | SCALE | NTS | DRAWING NO.           |
| SIGN  |       |     | <b>3-WT-310-00031</b> |
| DATE  |       |     | SHEET 1 OF 1 REV. 01  |

ALL DIMENSIONS ARE IN MILLIMETRES  
FOR PRODUCTION  
REF. PR:QA:590 FOR PAINTING  
REF. PR:QA:500 FOR UNTOL. DIMNS.  
REF. APPLICABLE GMS FOR MATCODE&SPEC.

PI-REMOTE MOUNTING

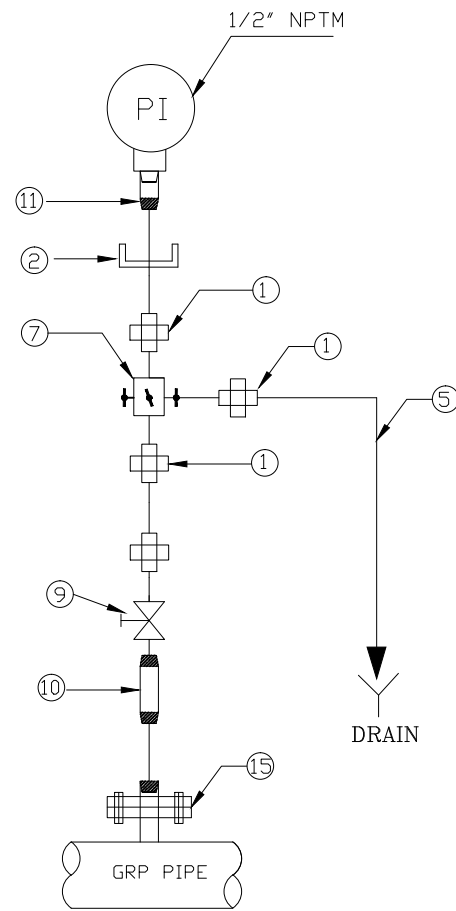

PI-DIRECT MOUNTING

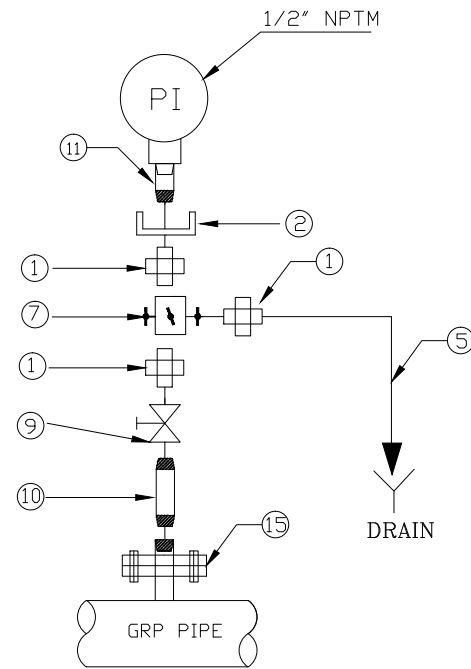

| SI. NO | ITEM. NO. | ITEM DESCRIPTION                                                                                                     | QUANTITY IN NOS |
|--------|-----------|----------------------------------------------------------------------------------------------------------------------|-----------------|
| 1      | 1         | 1/2" NPT SS316, double compression ferrule type male connector                                                       | 3               |
| 2      | 2         | 1/2" NPT SS316, double compression ferrule type female connector                                                     | 1               |
| 5      | 5         | 1/2" OD SS tube-5metres                                                                                              | 1               |
| 6      | 7         | 3 valve manifold                                                                                                     | 1               |
| 9      | 9         | 1/2" NB SS316 Ball Valve, 2 way with 1/2" NPT internal thread at both ends                                           | 1               |
| 10     | 10        | 1/2" NB pipe nipple                                                                                                  | 1               |
| 11     | 11        | 1/2" female NPT to male NPT adaptor                                                                                  | 1               |
| 12     | 15        | 1/2" NB Threaded flange with internal thread 1/2" NPT as per ANSI B16.5, 150 class with suitable gasket & fassteness | 1               |

| SI. NO | ITEM. NO. | ITEM DESCRIPTION                                                                                                     | QUANTITY IN NOS |
|--------|-----------|----------------------------------------------------------------------------------------------------------------------|-----------------|
| 1      | 1         | 1/2" NPT SS316, double compression ferrule type male connector                                                       | 4               |
| 2      | 2         | 1/2" NPT SS316, double compression ferrule type female connector                                                     | 1               |
| 3      | 5         | 1/2" OD SS tube-10metres                                                                                             | 1               |
| 4      | 7         | 3 valve manifold                                                                                                     | 1               |
| 5      | 9         | 1/2" NB SS316 Ball Valve, 2 way with 1/2" NPT internal thread at both ends                                           | 1               |
| 6      | 10        | 1/2" NB pipe nipple                                                                                                  | 1               |
| 7      | 11        | 1/2" female NPT to male NPT adaptor                                                                                  | 1               |
| 8      | 15        | 1/2" NB Threaded flange with internal thread 1/2" NPT as per ANSI B16.5, 150 class with suitable gasket & fassteness | 1               |

NOTE:

- THIS INSTRUMENT SHALL BE MOUNTED ON A STEEL FRAME FABRICATED AT SITE AND MOUNTED NEAR BY STRUCTURE OR FIXED ON AN ANGLE IRON FRAME WORK GROUDED TO THE FLOOR. THE FRAME HAS TO BE EPOXY PAINTED IN LIGHT GREY COLOUR.
- THIS INSTRUMENT SHALL BE LOCATED AT A SUITABLE LOCATION ON THE GROUND TO ENABLE EASY ACCESS TO THE OPERATOR FOR TAKING READINGS. THE TUBING IS TO BE SUITABLY ROUTED TO THE INSTRUMENT.
- REFER TO INSTALLATION INSTRUCTIONS DRG. NO: 4-WT-310-00017
- THE IMPULSE LINE SHALL BE ROUTED THROUGH PERFORATED CABLE TRAY WITH SUITABLE SUPPORTS.
- DRAIN LINE ARE TO BE CONNECTED IN THE DRAIN TRENCH

| REV  | DATE             | ALTERED | IRS |
|------|------------------|---------|-----|
| 01   | 04.12.12         | CHECKED | RPS |
| ZONE | NOTE 4 & 5 ADDED |         |     |

|                                                                                       |                                                                                                                                                                                                                              |                 |                                      |                                                         |
|---------------------------------------------------------------------------------------|------------------------------------------------------------------------------------------------------------------------------------------------------------------------------------------------------------------------------|-----------------|--------------------------------------|---------------------------------------------------------|
|  | <b>BHARAT HEAVY ELECTRICALS LTD</b><br>UNIT : BOILER AUXILIARIES PLANT<br>RANIPET-632 406                                                                                                                                    |                 |                                      |                                                         |
|                                                                                       | COPY RIGHT AND CONFIDENTIAL<br>The inforMation on this docuMent is the property of<br>BHARAT HEAVY ELECTRICALS LIMITED it Must not be used directly or<br>indirectly in any way deteriMental to the interest of the coMpany. |                 | DEPT<br>CODE<br>876                  | NAME<br>ACK<br>DESN<br>ACK<br>CHD<br>RPS<br>APPD<br>DNB |
| <b>TITLE</b><br>PRESSURE INDICATOR INSTALLATION IN GRP LINE (TYPICAL)                 |                                                                                                                                                                                                                              |                 |                                      |                                                         |
|                                                                                       |                                                                                                                                                                                                                              | DEPT. SCALE NTS | DRAWING NO.<br><b>3-WT-310-00032</b> |                                                         |
|                                                                                       |                                                                                                                                                                                                                              | SIGN DATE       | SHEET 1 OF 1                         | REV. 01                                                 |

FOR PRODUCTION  
 REF. PR:QA:590 FOR PAINTING  
 REF. PR:QA:500 FOR UNTOL. DIMNS.  
 REF. APPLICABLE GMS FOR MATCODE&SPEC.

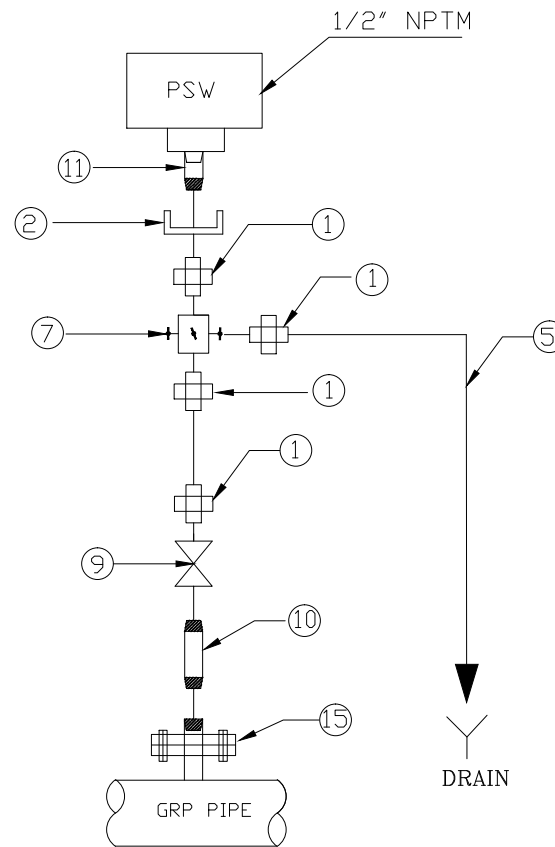

NOTE:

- 1 THIS INSTRUMENT SHALL BE MOUNTED ON A 2.5MM THICK MS SHEET WHICH SHALL BE WELDED TO A NEAR BY STRUCTURE OR FIXED ON AN ANGLE IRON FRAMEWORK GROUTED TO THE FLOOR. THE MS SHEET HAS TO BE EPOXY PAINTED IN LIGHT GREY COLOUR.
- 2 THIS INSTRUMENT SHALL BE LOCATED AT A SUITABLE LOCATION ON THE GROUND TO ENABLE EASY ACCESS TO THE OPERATOR FOR TAKING READINGS. THE TUBING IS TO BE SUITABLY ROUTED TO THE INSTRUMENT.
- 3 REFER TO INSTALLATION INSTRUCTIONS DRG. NO: 4-WT-310-00017
- 4 THE IMPULSE LINE SHALL BE ROUTED THROUGH PERFORATED CABLE TRAY WITH SUITABLE SUPPORTS.
- 5 DRAIN LINE ARE TO BE CONNECTED IN THE DRAIN TRENCH

| SI. NO | ITEM. NO. | ITEM DESCRIPTION                                                                                                    | QUANTITY IN NOS |
|--------|-----------|---------------------------------------------------------------------------------------------------------------------|-----------------|
| 1      | 1         | 1/2" NPT SS316, double compression ferrule type male connector                                                      | 4               |
| 2      | 2         | 1/2" NPT SS316, double compression ferrule type female connector                                                    | 1               |
| 3      | 5         | 1/2" OD SS tube-10metres                                                                                            | 1               |
| 4      | 7         | 3 valve manifold                                                                                                    | 1               |
| 5      | 9         | 1/2" NB SS316 Ball Valve, 2 way with 1/2" NPT internal thread at both ends                                          | 1               |
| 6      | 10        | 1/2" NB pipe nipple                                                                                                 | 1               |
| 7      | 11        | 1/2" female NPT to male NPT adaptor                                                                                 | 1               |
| 8      | 15        | 1/2" NB Threaded flange with internal thread 1/2" NPT as per ANSI B16.5, 150 class with suitable gasket & fasteners | 1               |

| REV                   | DATE     | ALTERED | IRS |
|-----------------------|----------|---------|-----|
| 01                    | 04.12.12 | CHECKED | RPS |
| ZONE NOTE 4 & 5 ADDED |          |         |     |

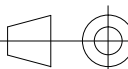
|                                                                                                                        |                                                                                                                                                                                                                       |                                                                                            |                                      |                                                    |
|------------------------------------------------------------------------------------------------------------------------|-----------------------------------------------------------------------------------------------------------------------------------------------------------------------------------------------------------------------|--------------------------------------------------------------------------------------------|--------------------------------------|----------------------------------------------------|
|                                   | BHARAT HEAVY ELECTRICALS LTD<br>UNIT : BOILER AUXILIARIES PLANT<br>RANIPET-632 406                                                                                                                                    |                                                                                            |                                      |                                                    |
|                                                                                                                        | COPY RIGHT AND CONFIDENTIAL<br>The information on this document is the property of BHARAT HEAVY ELECTRICALS LIMITED it must not be used directly or indirectly in any way detrimental to the interest of the company. |                                                                                            | DEPT CODE<br>876                     | NAME<br>DRN ACK<br>DESN ACK<br>CHD RPS<br>APPD DNB |
| TITLE <b>PRESSURE INDICATING TRANSMITTER / PRESSURE SWITCH<br/>                 INSTALLATION IN GRP LINE (TYPICAL)</b> |                                                                                                                                                                                                                       |                                                                                            |                                      |                                                    |
|                                                                                                                        |                                                                                                                                                                                                                       | DEPT. SCALE <b>NTS</b>                                                                     | DRAWING NO.<br><b>3-WT-310-00033</b> |                                                    |
|                                                                                                                        |                                                                                                                                                                                                                       | SIGN  | SHEET 1 OF 1 REV. 01                 |                                                    |

ALL DIMENSIONS ARE IN MILLIMETRES

FOR PRODUCTION  
 REF. PR:QA:590 FOR PAINTING  
 REF. PR:QA:500 FOR UNTOL. DIMNS.  
 REF. APPLICABLE GMS FOR MATCODE&SPEC.

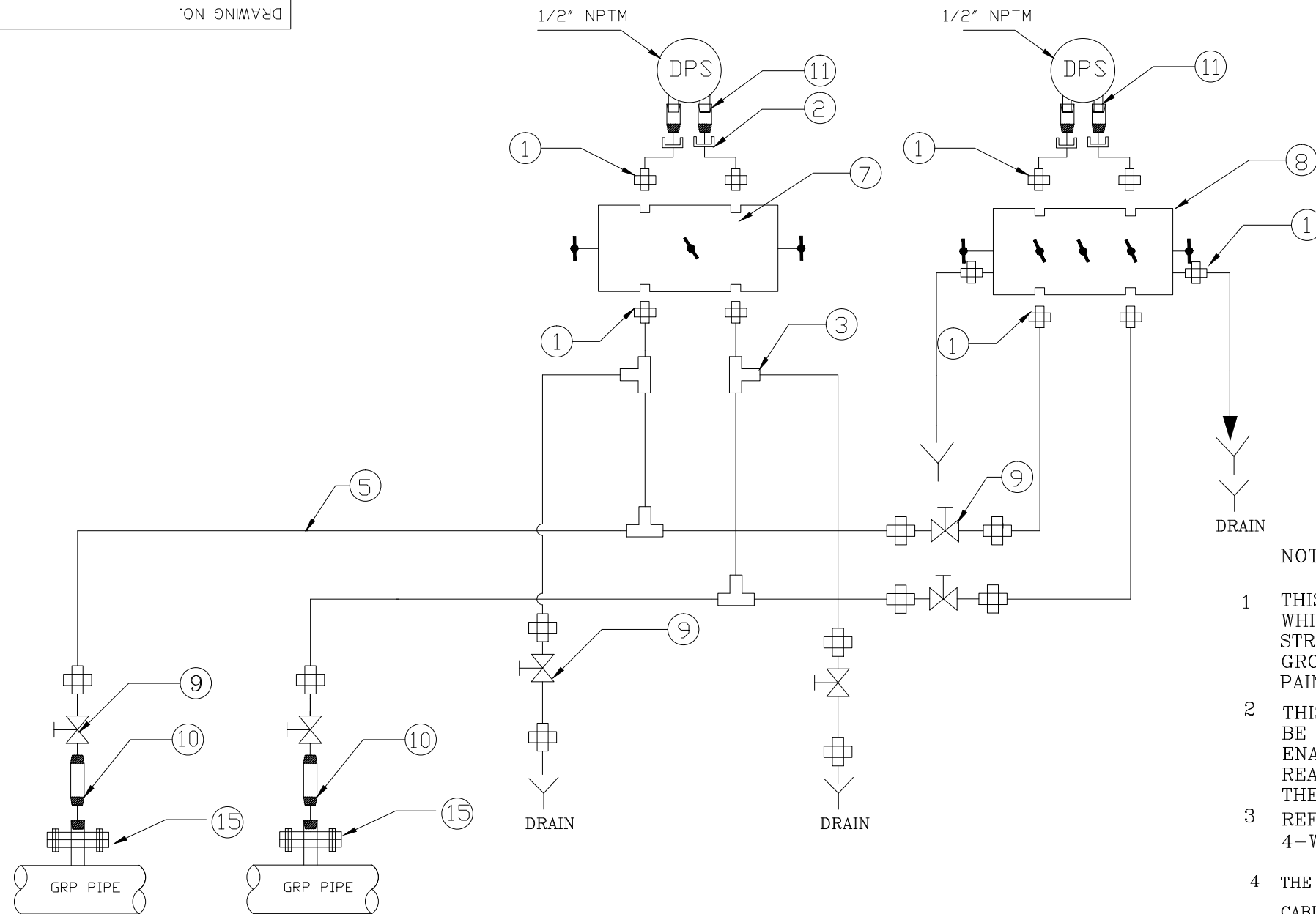

NOTE:

- 1 THIS INSTRUMENT SHALL BE MOUNTED ON A FRAME WHICH SHALL BE WELDED TO A NEAR BY STRUCTURE OR FIXED ON AN ANGLE IRON FRAMEWORK GROUDED TO THE FLOOR. THE FRAME HAS TO BE EPOXY PAINTED IN LIGHT GREY COLOUR.
- 2 THIS INSTRUMENT & 3 VALVE/ 5 VALVE MANIFOLD SHALL BE LOCATED AT A SUITABLE LOCATION IN THE GROUND TO ENABLE EASY ACCESS TO THE OPERATOR FOR TAKING READINGS. THE TUBING IS TO BE SUITABLY ROUTED TO THE INSTRUMENT.
- 3 REFER TO INSTALLATION INSTRUCTIONS DRG. NO: 4-WT-310-00017
- 4 THE IMPULSE LINE SHALL BE ROUTED THROUGH PERFORATED CABLE TRAY WITH SUITABLE SUPPORTS.
- 5 DRAIN LINE ARE TO BE CONNECTED IN THE DRAIN TRENCH

| SI. NO | ITEM. NO. | ITEM DESCRIPTION                                                                                                    | QUANTITY IN NOS |
|--------|-----------|---------------------------------------------------------------------------------------------------------------------|-----------------|
| 1      | 1         | 1/2" NPT SS316, double compression ferrule type male connector                                                      | 20              |
| 2      | 2         | 1/2" NPT SS316, double ompression ferrule type female connector                                                     | 4               |
| 3      | 3         | Equal Tee                                                                                                           | 4               |
| 5      | 5         | 1/2" OD SS tube-20metres                                                                                            | 1               |
| 7      | 7         | 3 valve manifold                                                                                                    | 1               |
| 8      | 8         | 5 valve manifold                                                                                                    | 1               |
| 9      | 9         | 1/2" NB SS316 Ball Valve, 2 way with 1/2" NPT internal thread at both ends                                          | 6               |
| 10     | 10        | 1/2" NB pipe nipple                                                                                                 | 2               |
| 11     | 11        | 1/2" female NPT to male NPT adaptor                                                                                 | 4               |
| 12     | 15        | 1/2" NB Threaded flange with internal thread 1/2" NPT as per ANSI B16.5, 150 class with suitable gasket & fasteners | 2               |

| REV                   | DATE     | ALTERED | IRS |
|-----------------------|----------|---------|-----|
| 01                    | 04.12.12 | CHECKED | RPS |
| ZONE NOTE 4 & 5 ADDED |          |         |     |



**BHARAT HEAVY ELECTRICALS LTD**  
 UNIT : BOILER AUXILIARIES PLANT  
 RANIPET-632 406

COPY RIGHT AND CONFIDENTIAL  
 The information on this document is the property of BHARAT HEAVY ELECTRICALS LIMITED it must not be used directly or indirectly in any way detrimental to the interest of the company.

| DEPT CODE | DRN | NAME | SIGN | DATE |
|-----------|-----|------|------|------|
| 876       | ACK |      |      |      |
|           | ACK |      |      |      |
|           | RPS |      |      |      |
|           | DNB |      |      |      |

**TITLE DP INDICATING TRANSMITTER/ DP SWITCH INSTALLATION IN GRP LINE (TYPICAL)**

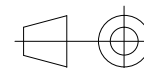
|       |                                                                                       |              |                       |
|-------|---------------------------------------------------------------------------------------|--------------|-----------------------|
| DEPT. | SCALE                                                                                 | NTS          | DRAWING NO.           |
| SIGN  |  |              | <b>3-WT-310-00034</b> |
| DATE  |                                                                                       | SHEET 1 OF 1 | REV. 01               |

3-WT-310-00035  
DRAWING NO.

ALL DIMENSIONS ARE IN MILLIMETRES

FOR PRODUCTION  
REF. PR:QA:590 FOR PAINTING  
REF. PR:QA:500 FOR UNTOL. DIMNS.  
REF. APPLICABLE GMS FOR MATCODE&SPEC.

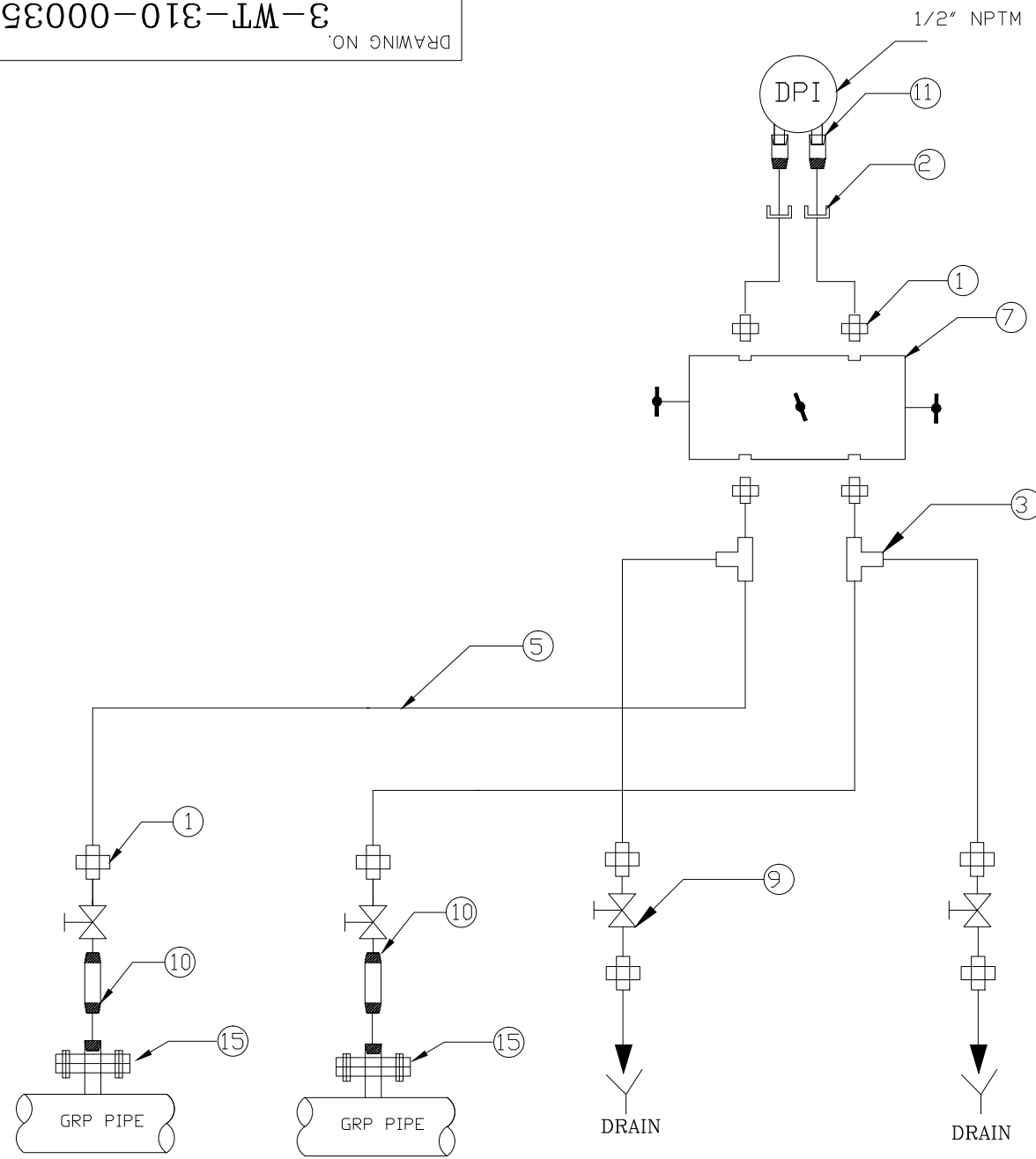

NOTES:

- 1 THIS INSTRUMENT SHALL BE MOUNTED ON A FRAME WHICH SHALL BE WELDED TO A NEAR BY STRUCTURE OR FIXED ON AN ANGLE IRON FRAME WORK GROUDED TO THE FLOOR. THE FRAME HAS TO BE EPOXY PAINTED IN LIGHT GREY COLOUR.
- 2 THIS INSTRUMENT & 3 VALVE MANIFOLD SHALL BE LOCATED AT A SUITABLE LOCATION ON THE GROUND TO ENABLE EASY ACCESS TO THE OPERATOR FOR TAKING READINGS. THE TUBING IS TO BE SUITABLY ROUTED TO THE INSTRUMENT.
- 3 REFER TO INSTALLATION INSTRUCTIONS DRG. NO: 4-WT-310-00017
- 4 THE IMPULSE LINE SHALL BE ROUTED THROUGH PERFORATED CABLE TRAY WITH SUITABLE SUPPORTS.
- 5 DRAIN LINE ARE TO BE CONNECTED IN THE DRAIN TRENCH

| SI. NO | ITEM NO. | ITEM DESCRIPTION                                                                                                    | QUANTITY IN NOS |
|--------|----------|---------------------------------------------------------------------------------------------------------------------|-----------------|
| 1      | 1        | 1/2" NPT SS316, double compression ferrule type male connector                                                      | 10              |
| 2      | 2        | 1/2" NPT SS316, double ompression ferrule type female connector                                                     | 2               |
| 3      | 3        | Equal Tee                                                                                                           | 2               |
| 4      | 5        | 1/2" OD SS tube-10metres                                                                                            | 1               |
| 5      | 7        | 3 valve manifold                                                                                                    | 1               |
| 6      | 9        | 1/2" NB SS316 Ball Valve, 2 way with 1/2" NPT internal thread at both ends                                          | 4               |
| 7      | 10       | 1/2" NB pipe nipple                                                                                                 | 2               |
| 8      | 11       | 1/2" female NPT to male NPT adaptor                                                                                 | 2               |
| 9      | 15       | 1/2" NB Threaded flange with internal thread 1/2" NPT as per ANSI B16.5, 150 class with suitable gasket & fasteners | 2               |

| REV                   | DATE     | ALTERED | IRS |
|-----------------------|----------|---------|-----|
| 01                    | 04.12.12 | CHECKED | RPS |
| ZONE NOTE 4 & 5 ADDED |          |         |     |

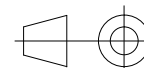
|                                                                                       |                                                                                                                                                                                                                       |          |                       |         |
|---------------------------------------------------------------------------------------|-----------------------------------------------------------------------------------------------------------------------------------------------------------------------------------------------------------------------|----------|-----------------------|---------|
|  | BHARAT HEAVY ELECTRICALS LTD<br>UNIT : BOILER AUXILIARIES PLANT<br>RANIPET-632 406                                                                                                                                    |          |                       |         |
|                                                                                       | COPY RIGHT AND CONFIDENTIAL<br>The information on this document is the property of BHARAT HEAVY ELECTRICALS LIMITED it must not be used directly or indirectly in any way detrimental to the interest of the company. |          |                       |         |
| DEPT CODE                                                                             | DRN                                                                                                                                                                                                                   | NAME ACK | SIGN                  | DATE    |
| 876                                                                                   | CHD                                                                                                                                                                                                                   | RPS      |                       |         |
|                                                                                       | APPD                                                                                                                                                                                                                  | DNB      |                       |         |
| TITLE <b>DIFFERENT PRESSURE GAUGE INSTALLATION IN GRP LINE (TYPICAL)</b>              |                                                                                                                                                                                                                       |          |                       |         |
| DEPT.                                                                                 | SCALE                                                                                                                                                                                                                 | NTS      | DRAWING NO.           |         |
| SIGN                                                                                  |                                                                                                                                  |          | <b>3-WT-310-00035</b> |         |
| DATE                                                                                  |                                                                                                                                                                                                                       |          | SHEET 1 OF 1          | REV. 01 |

**ANNEXURE-A**  
**VENDORS LIST FOR MB SYSTEM**

|                                                |                             |                                          |
|------------------------------------------------|-----------------------------|------------------------------------------|
|                                                | <b>DOC. NO :</b>            | <b>4-WT-220-00488 Rev.00</b>             |
| <b>Cust. No.: R4K6</b>                         |                             | <b>Dtd. 20.06.16</b>                     |
| <b>PROJECT : M/S.KPCL, YELAHANKA (1x370MW)</b> |                             |                                          |
|                                                |                             | <b>MECHANICAL</b>                        |
| <b>SL.No</b>                                   | <b>Description of Items</b> | <b>Vendors Proposed</b>                  |
| 1                                              | LP CENTRIFUGAL PUMPS        | KIRLOSKAR, CHENNAI                       |
|                                                |                             | FLOWSERVE, COIMBATORE                    |
|                                                |                             | SULZER PUMPS INDIA LTD., CHENNAI         |
|                                                |                             | MATHER & PLATT, CHENNAI                  |
|                                                |                             | BEST AND CROMPTON ENGG LIMITED., CHENNAI |
|                                                |                             | WIPL LTD, CHENNAI                        |
|                                                |                             | KSB PUMPS LTD., CHENNAI                  |
|                                                |                             | GRUNDFOS PUMPS INDIA LTD., CHENNAI       |
|                                                |                             | FLOWMORE LIMITED., GURGAON               |
| 2                                              | BALL VALVES                 | WEIR BDK, CHENNAI                        |
|                                                |                             | MICROFINISH VALVES , HUBLI               |
|                                                |                             | VIRGO ENGINEERS LIMITD                   |
|                                                |                             | BRAY CONTROL INDIA Pvt. LTD, VADODARA    |
|                                                |                             | SIGMA INDUSTRIES, BOMBAY                 |
| 3                                              | BUTTERFLY VALVES            | KIRLOSKAR                                |
|                                                |                             | L&T, CHENNAI                             |
|                                                |                             | WEIR BDK, CHENNAI                        |
|                                                |                             | CRANE PROCESS - ALFA LAVAL(Saunders) *   |
|                                                |                             | INTER VALVE (POONAWALLA)                 |
|                                                |                             | MICROFINISH VALVES , HUBLI               |
|                                                |                             | SIGMA INDUSTRIES, BOMBAY                 |
|                                                |                             | BRAY VALVES LTD                          |
| 4                                              | DIAPHRAGM VALVES            | PROCON ENGINEERS LTD                     |
|                                                |                             | WEIR BDK, CHENNAI                        |

| ELECTRICAL & C&I |                        |                                               |
|------------------|------------------------|-----------------------------------------------|
| SL.NO            | DESCRIPTION OF ITEMS   | VENDORS PROPOSED                              |
| 1                | CONTROL CABLES         | KEI INDUSTRIES, NEW DELHI                     |
|                  |                        | NICCO CORP. PVT. LTD, CHENNAI / KOLKATTA      |
|                  |                        | DELTON CABLES, NEW DELHI                      |
|                  |                        | PARAMOUNT COMMUNICATION LTD,NEW DELHI         |
|                  |                        | POLYCAB WIRES PVT LTD,MUMBAI                  |
|                  |                        | CORDS CABLE INDUSTRIES LIMITED,NEW DELHI      |
|                  |                        | ELKAY TELELINKS LTD,FARIDABAD                 |
|                  |                        | GOYOLENE FIBRE (I) PVT LTD,MUMBAI             |
|                  |                        | KRISHNA ELECTRICAL INDUSTRIES LIMITED,GWALIOR |
|                  |                        | TORRENT CABLES LTD,AHMEDABAD                  |
|                  |                        | RAVIN CABLES LTD,MUMBAI                       |
|                  |                        | GEMSCAB INDUSTRIES LIMITED,DELHI              |
|                  |                        | INDUSTRIAL CABLES RAJPURA, CHENNAI,KOLKATA.   |
| 2                | INSTRUMENTATION CABLES | KEI INDUSTRIES, NEW DELHI                     |
|                  |                        | DELTON CABLES, NEW DELHI                      |
|                  |                        | PARAMOUNT COMMUNICATION LTD,NEW DELHI         |
|                  |                        | POLYCAB WIRES PVT LTD,MUMBAI                  |
|                  |                        | CORDS CABLE INDUSTRIES LIMITED,NEW DELHI      |
|                  |                        | ELKAY TELELINKS LTD,FARIDABAD                 |
|                  |                        | TORRENT CABLES LTD,AHMEDABAD                  |
|                  |                        | THERMO CABLES LIMITED,HYDERABAD               |
|                  |                        | C M I LTD.,,FARIDABAD                         |
|                  |                        | INDUSTRIAL CABLES RAJPURA, CHENNAI,KOLKATA.   |
|                  |                        | NICCO CORP. PVT. LTD, CHENNAI / KOLKATTA      |
|                  |                        | RADIANT CORPORATION PRIVATE LIMITED           |
| 3                | LT MOTORS              | BHARAT BIJILEE LTD,MUMBAI                     |
|                  |                        | CROMPTON GREAVES LTD,CHENNAI                  |
|                  |                        | SIEMENS LTD,JOKA                              |
|                  |                        | ABB,CHENNAI                                   |
|                  |                        | KIRLOSKAR ELECTRIC CO. LTD,BENGALORE          |
|                  |                        | NGEF (HUBLI) LTD,BENGALORE                    |

|    |                                    |                                           |
|----|------------------------------------|-------------------------------------------|
| 4  | CONDUCTIVITY ,PH,ORP MEASUREMENT   | <b>INSTRUMENTS</b>                        |
|    |                                    | HONEYWELL                                 |
|    |                                    | HACH                                      |
|    |                                    | YOKOGAWA                                  |
|    |                                    | ABB                                       |
|    |                                    | E & H                                     |
|    |                                    | EMERSON PROCESS MANAGEMENT(INDIA) PVT LTD |
|    |                                    | FORBES MARSHALL PVT. LTD.,                |
|    |                                    | POLYMETRON                                |
| 5  | DIFFERENTIAL PRESSURE              | SWITZER INSTRUMENTS LTD.                  |
|    | SWITCHES                           | VARMA TRAFAG                              |
|    |                                    | BAUMER TECHNOLOGIES INDIA PVT LTD.,       |
|    |                                    | INDFOSS (INDIA) LTD                       |
|    |                                    | AN INSTRUMENTS                            |
|    |                                    | BELLS CONTROLS LTD                        |
|    |                                    | WAAREE INSTRUMENTS LIMITED                |
|    |                                    | GIC                                       |
|    |                                    | GAUGES BOURDON PVT. LTD                   |
| 6  | PRESSURE / TEMP./ LEVEL/FLOW       | HONEYWELL                                 |
|    | DIFFERENTIAL PRESSURE              | YOKOGAWA                                  |
|    | TRANSMITTER                        | EMERSON PROCESS MANAGEMENT(INDIA) PVT LTD |
|    |                                    | ABB                                       |
|    |                                    | E & H                                     |
|    |                                    | SIEMENS INDIA LTD                         |
| 7  | RECEIVER RECORDER /                | YOKOGAWA                                  |
|    | MULTIPOINT RECORDER/               | HONEYWELL                                 |
|    | PAPERLESS RECORDER                 | ABB                                       |
|    |                                    | EMERSON                                   |
| 8  | SOLENOID VALVES                    | ASCO                                      |
|    |                                    | AVCON                                     |
|    |                                    | ROTEX                                     |
|    |                                    | NUCON                                     |
| 10 | FLOW INDICATORS(PADDLE WHEEL TYPE) | GEORGE FISHER,SWITZERLAND                 |
|    |                                    | BURKERT USA                               |

|    |                    |                                             |
|----|--------------------|---------------------------------------------|
| 11 | SILICA MEASUREMENT | HACH                                        |
|    |                    | EMERSON                                     |
|    |                    | FORBES MARSHALL, PUNE                       |
|    |                    | STEAM EQUIPMENT, PUNE                       |
|    |                    | FLOW LINE INSTRUMENT, BANGALORE             |
|    |                    | ENDRESS & HAUSER, PUNE                      |
| 12 | PNEUMATIC ACTUATOR | ELOMATIC INDIA LTD                          |
|    | (ON / OFF)         | VIRGO ENGINEERS LTD                         |
|    |                    | FISCHER XOMOX LTD                           |
|    |                    | CRANE PROCESS FLOW TECHNOLOGIES (REVO MAKE) |
|    |                    | WEIR BDK                                    |
|    |                    | MIL, KOCHIN KERALA                          |
|    |                    | ROTEX LTD                                   |
|    |                    | INSTRUMENTATION LIMITED, Palakkad           |

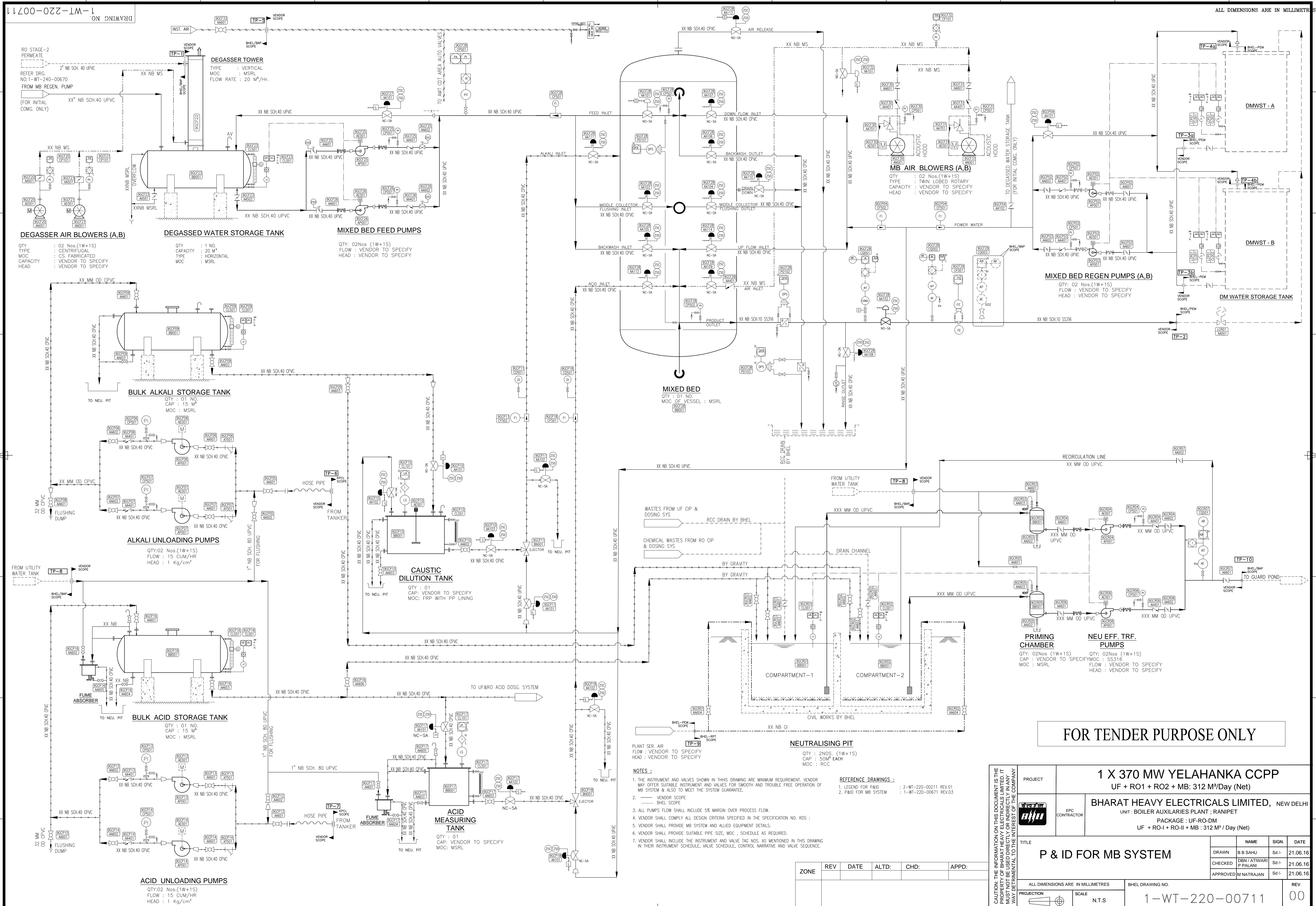

DRAWING NO. 1-WT-220-00711

ALL DIMENSIONS ARE IN MILLIMETRS

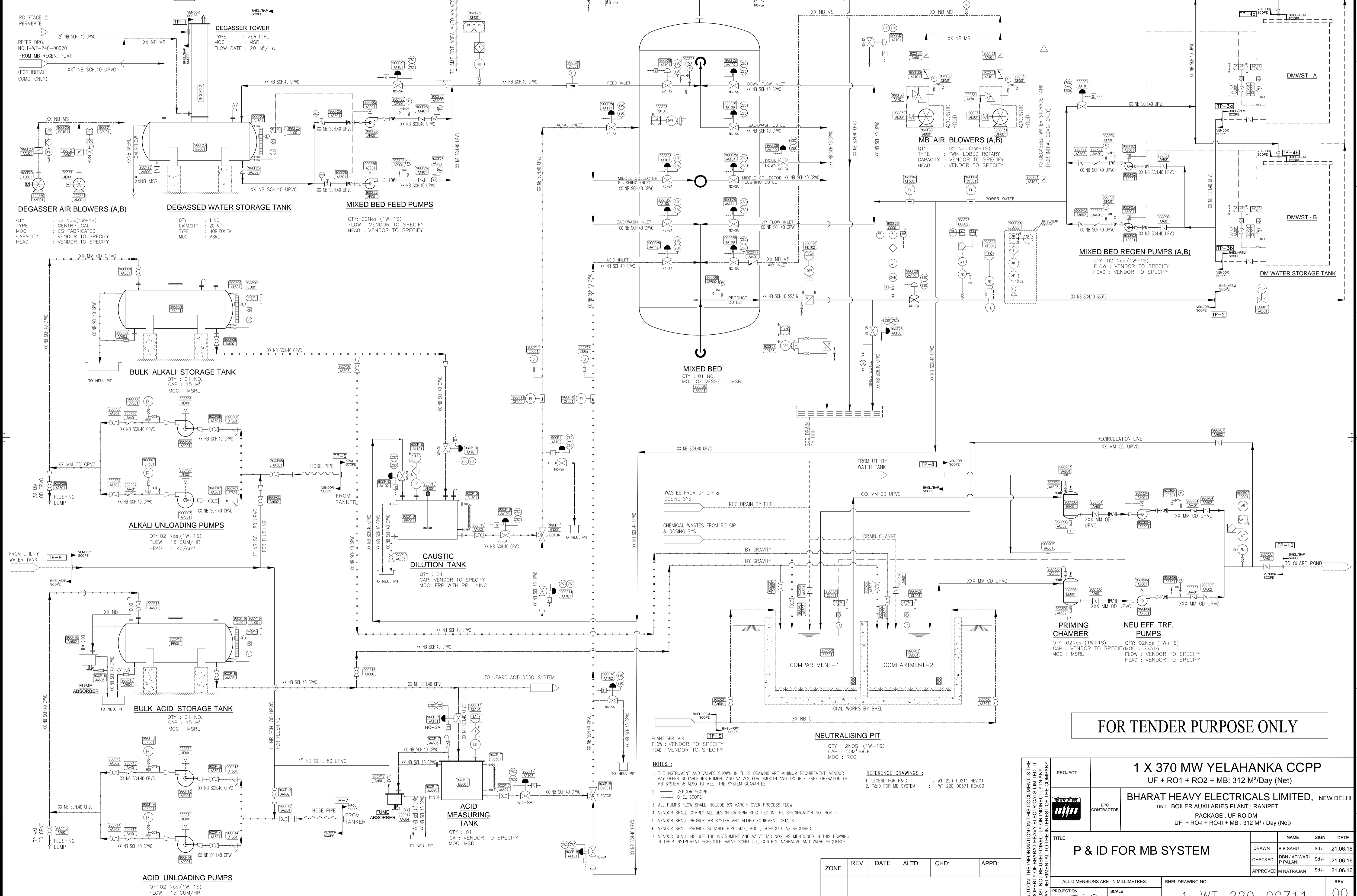

FOR TENDER PURPOSE ONLY

|                      |       |                                                                                                                                                                       |                  |     |
|----------------------|-------|-----------------------------------------------------------------------------------------------------------------------------------------------------------------------|------------------|-----|
| PROJECT              |       | 1 X 370 MW YELAHANKA CAPP<br>UF + RO1 + RO2 + MB: 312 M <sup>3</sup> /Day (Net)                                                                                       |                  |     |
| EPC CONTRACTOR       |       | BHARAT HEAVY ELECTRICALS LIMITED, NEW DELHI<br>UNIT: BOILER AUXILIARIES PLANT; RANIPET<br>PACKAGE: UF-RO-DM<br>UF + RO-I + RO-II + MB: 312 M <sup>3</sup> / Day (Net) |                  |     |
| TITLE                |       | P & ID FOR MB SYSTEM                                                                                                                                                  |                  |     |
| NAME                 | SIGN. | DATE                                                                                                                                                                  |                  |     |
| DRAWN: B B SAHU      | Sd/-  | 21.06.16                                                                                                                                                              |                  |     |
| CHECKED: DSN/ATWARI  | Sd/-  | 21.06.16                                                                                                                                                              |                  |     |
| APPROVED: M NATRAJAN | Sd/-  | 21.06.16                                                                                                                                                              |                  |     |
| PROJECTION           |       | SCALE                                                                                                                                                                 | BHEL DRAWING NO. |     |
| N.T.S                |       | 1-WT-220-00711                                                                                                                                                        |                  | REV |
|                      |       |                                                                                                                                                                       |                  | 00  |

- PLANT SER. AIR  
FLOW: VENDOR TO SPECIFY  
HEAD: VENDOR TO SPECIFY
- NOTES:
- THE INSTRUMENT AND VALVES SHOWN IN THIS DRAWING ARE MINIMUM REQUIREMENT. VENDOR MAY OFFER SUITABLE INSTRUMENT AND VALVES FOR SMOOTH AND TROUBLE FREE OPERATION OF MB SYSTEM & ALSO TO MEET THE SYSTEM GUARANTEE.
  - VENDOR SCOPE  
BHEL SCOPE
  - ALL PUMPS FLOW SHALL INCLUDE 5% MARGIN OVER PROCESS FLOW.
  - VENDOR SHALL COMPLY ALL DESIGN CRITERIA SPECIFIED IN THE SPECIFICATION NO. R05
  - VENDOR SHALL PROVIDE MB SYSTEM AND ALLIED EQUIPMENT DETAILS.
  - VENDOR SHALL PROVIDE SUITABLE PIPE SIZE, MOC, SCHEDULE AS REQUIRED.
  - VENDOR SHALL INCLUDE THE INSTRUMENT AND VALVE TAG NOS. AS MENTIONED IN THIS DRAWING IN THEIR INSTRUMENT SCHEDULE, VALVE SCHEDULE, CONTROL NARRATIVE AND VALVE SEQUENCE.
- REFERENCE DRAWINGS:
- LEGEND FOR P&ID : 2-WT-220-00211 REV.01
  - P&ID FOR MB SYSTEM : 1-WT-220-00671 REV.03
- | ZONE | REV | DATE | ALTD: | CHD: | APPD: |
|------|-----|------|-------|------|-------|
|      |     |      |       |      |       |

11Z00-02Z-1M-2  
DRAWING NO.

| VALVES & FITTINGS                                 | ACCESSORIES                    | EQUIPMENTS                                                                                                                                                                                                                                                                                                                                                 | INSTRUMENTS                                                                                           |
|---------------------------------------------------|--------------------------------|------------------------------------------------------------------------------------------------------------------------------------------------------------------------------------------------------------------------------------------------------------------------------------------------------------------------------------------------------------|-------------------------------------------------------------------------------------------------------|
| NEEDLE VALVE                                      | PULSATION DAMPENER             | CENTRIFUGAL PUMP                                                                                                                                                                                                                                                                                                                                           | LOCAL INSTRUMENT INCLUDING TRANSMITTER FOR SINGLE MEASURED VARIABLE                                   |
| GLOBE VALVE                                       | MOTOR DRIVEN MIXER             | BASKET STRAINER                                                                                                                                                                                                                                                                                                                                            | RO - DM DCS PANEL DISPLAY                                                                             |
| BALL VALVE                                        | MANUAL MIXER                   | CHEMICAL DOSING PUMP                                                                                                                                                                                                                                                                                                                                       | TO PLC                                                                                                |
| BALL CHECK VALVE                                  | DRAIN TO WASTE                 | RO MEMBRANES                                                                                                                                                                                                                                                                                                                                               | RO - DM DCS PANEL INTERLOCK                                                                           |
| BUTTERFLY VALVE                                   | VENT                           | AIR BLOWER                                                                                                                                                                                                                                                                                                                                                 | ROTAMETER                                                                                             |
| CHECK VALVE                                       | MOTOR OPERATED                 | STATIC MIXER                                                                                                                                                                                                                                                                                                                                               | DIRECT FLOW MEASUREMENT (PADDLE WHEEL SENSOR)                                                         |
| DIAPHRAGM VALVE                                   | PNEUMATIC ACTUATOR             | RESIN TRAP                                                                                                                                                                                                                                                                                                                                                 | DIRECT FLOW MEASUREMENT (MAGNETIC SENSOR)                                                             |
| SOLENOID VALVE                                    | PISTON OPERATED                | MEDIA TRAP                                                                                                                                                                                                                                                                                                                                                 | REMOTE INSTRUMENT FOR SINGLE MEASURED VARIABLE                                                        |
| RELIEF VALVE                                      | SOLENOID OPERATED              | EJECTOR                                                                                                                                                                                                                                                                                                                                                    | VARIABLE FREQUENCY DRIVE                                                                              |
| 3 WAY VALVE                                       | AIR RELEASE                    | FUME ABSORBER                                                                                                                                                                                                                                                                                                                                              |                                                                                                       |
| 4 WAY VALVE                                       | THREE VALVE MANIFOLD           | UF MEMBRANES                                                                                                                                                                                                                                                                                                                                               |                                                                                                       |
| REDUCER                                           | ORIFICE PLATE                  | TANK - TOP CLOSED                                                                                                                                                                                                                                                                                                                                          |                                                                                                       |
| ENLARGER                                          | HEATING ELEMENT                | TANK - TOP OPEN                                                                                                                                                                                                                                                                                                                                            |                                                                                                       |
| STRAINER                                          | CHEMICAL SEALED DIAPHRAGM      | ERD - ENERGY RECOVERY DEVICE                                                                                                                                                                                                                                                                                                                               |                                                                                                       |
| 'Y' TYPE STRAINER                                 | <b>PIPE LINES</b>              | VERTICAL CENTRIFUGAL PUMP                                                                                                                                                                                                                                                                                                                                  | <b>COMMON</b><br>W - WORKING<br>S - STAND BY<br>S - SAMPLE<br>MB - MIXED BED<br>DM - DEMINERALIZATION |
| FLEXIBLE CONNECTOR                                |                                | FLOW LINE                                                                                                                                                                                                                                                                                                                                                  |                                                                                                       |
| PUMP FOOT VALVE                                   |                                | EXISTING LINE / BY OTHERS                                                                                                                                                                                                                                                                                                                                  |                                                                                                       |
| PNEU. ACTUATED BVF NORMALLY OPEN                  | INSTRUMENT AIR LINE            | GATE VALVE WITH LIMIT SWITCH                                                                                                                                                                                                                                                                                                                               | CONTROL SIGNAL                                                                                        |
| PNEU. ACTUATED BVF NORMALLY CLOSED                | AIR LINE                       | FLOAT VALVE                                                                                                                                                                                                                                                                                                                                                | DAMPER VALVE                                                                                          |
| DOUBLE COIL SOLENOID VALVE                        | DRAIN LINE TO NEUTRALISING PIT | <b>VALVE TAG DESCRIPTION</b><br>ZSO - POSITION LIMIT SWITCH OPEN<br>ZSC - POSITION LIMIT SWITCH CLOSE<br>BCV - BRINE CONTROL VALVE<br>FCV - FLOW CONTROL VALVE<br>BBV - BCV BYPASS VALVE<br>NO-DA - NORMALLY OPEN DOUBLE ACTING.<br>NC-DA - NORMALLY CLOSE DOUBLE ACTING.<br>NO-SA - NORMALLY OPEN SINGLE ACTING.<br>NC-SA - NORMALLY CLOSE SINGLE ACTING. |                                                                                                       |
| MOTORISED VALVE (INCHING)                         | ACID LINE                      |                                                                                                                                                                                                                                                                                                                                                            |                                                                                                       |
| MANUAL VALVE WITH LIMIT SWITCH                    | CAUSTIC LINE                   |                                                                                                                                                                                                                                                                                                                                                            |                                                                                                       |
| FEED CONTROL VALVE (PNEU. CONTROLLED BVF)         | MANIFOLD                       |                                                                                                                                                                                                                                                                                                                                                            |                                                                                                       |
| FEED CONTROL VALVE (PNEU. CONTROLLED GLOBE VALVE) | MULTIPLE LINES                 |                                                                                                                                                                                                                                                                                                                                                            |                                                                                                       |

**INSTRUMENT IDENTIFICATION**

- AR - ANALYTICAL RECORDER
- L - ALARM LOW
- LL - ALARM LOW LOW
- TW - THERMO WELL
- TE - TEMPERATURE ELEMENT
- TG - TEMPERATURE GAUGE
- TA - TEMPERATURE ALARM
- TIT - TEMPERATURE INDICATING TRANSMITTER
- PG - PRESSURE GAUGE
- PS - PRESSURE SWITCH
- PIT - PRESSURE INDICATING TRANSMITTER
- PA - PRESSURE ALARM
- AE - ANALYZER ELEMENT
- AIT - ANALYZER INDICATING TRANSMITTER
- AI - ANALYSER INDICATOR
- AA - ANALYSER ALARM
- FE - FLOW ELEMENT
- FS - FLOW SWITCH
- FA - FLOW ALARM
- FIT - FLOW INDICATING TRANSMITTER
- FIQ - FLOW INDICATING TOTALISER
- DPI - DIFFERENTIAL PRESSURE INDICATOR
- DPS - DIFFERENTIAL PRESSURE SWITCH
- DPIT - DIFFERENTIAL PRESSURE INDICATING TRANSMITTER
- DPA - DIFFERENTIAL PRESSURE ALARM
- LS - LEVEL SWITCH
- LG - LEVEL GAUGE
- LIT - LEVEL INDICATING TRANSMITTER (ULTRASONIC TYPE)
- LA - LEVEL ALARM
- DI - DENSITY INDICATOR
- TUR - TURBIDITY
- ORP - OXIDATION REDUCTION POTENTIAL
- SDI - SILT DENSITY INDEX
- COND - CONDUCTIVITY
- SiO2 - SILICA
- pH - pH
- CL - RESIDUAL CHLORINE

**KKS CODING SYSTEM**

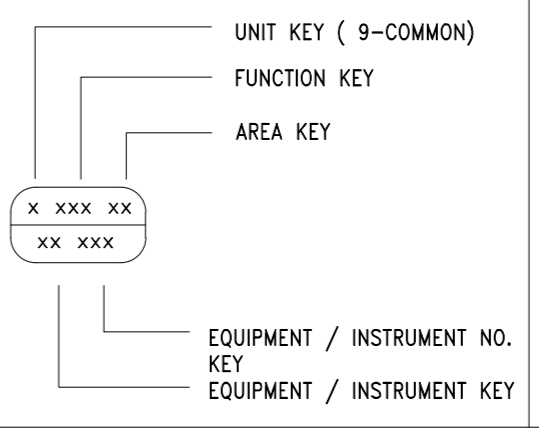

**FUNCTION KEY**

- GCB - CLARIFIER, PSF, ACF, UF & CF.
- GCF - CF OUTLET TO DM WATER TANK
- GCN - CC SYSTEM, DOSING SYSTEM
- GCP - REGENERATION, FLUSHING EQUIPMENT
- GCR - RESIDUAL REMOVAL & NEUTRALISATION
- GCS - CLARIFIER /UF SLUDGE DISPOSAL

**EXAMPLE**

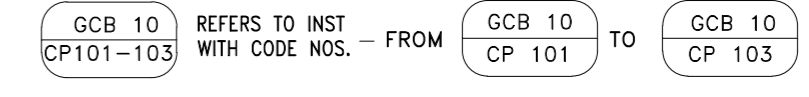

**EQUIPMENT/ INST. KEY**

- MECHANICAL :**  
 AP - PUMPS  
 AN - BLOWERS  
 AA - VALVES  
 AT - FILTERING ELEMENT  
 AM - MIXERS  
 BB - VESSELS AND STORAGE TANKS  
 BN - EJECTOR

- ELECT, C&I :**  
 AE - MOTORS  
 AH - HEATERS  
 CF - FLOW MEASUREMENT  
 CP - PRESSURE MEASUREMENT  
 CT - TEMPERATURE MEASUREMENT  
 CQ - ANALYTICAL MEASUREMENT  
 CL - LEVEL MEASUREMENT  
 CD - DENSITY MEASUREMENT  
 PD - DIFF. PR. MEASUREMENT

**EQUIPMENT/INST. NO. KEY**

- MECHANICAL :**  
 001 TO 050 EQUIPMENTS  
 051 TO 099 MOTORISED VALVE (INCHING DUTY)  
 101 TO 150 PNEU. ACTUATED VALVES  
 201 TO 299 SOLENOID OPERATED VALVES  
 401 TO 499 NON RETURN VALVES  
 501 TO 599 MANUAL VALVES - UF & RO SYSTEM  
 601 TO 699 MANUAL VALVES - MB, DOSING & CC SYSTEM  
 701 TO 799 PR. RELIEF VALVES

- ELECT, C&I :**  
 001 TO 099 ANALOG INSTRUMENTS - REMOTE  
 101 TO 199 PROCESS SWITCHES - LOCAL  
 501 TO 599 PROCESS INDICATORS - LOCAL

| ZONE | REV | DATE     | ALTD.   | CHD.      | APPD. |
|------|-----|----------|---------|-----------|-------|
|      | 01  | 23.02.16 | BB SAHU | DBN / VNS | MN    |

REVISED BASED ON CONSULTANT COMMENTS  
 WIDE LETTER NO : 3115191-2000-VE-VDT-026  
 dtd. 08.02.2016

**1 X 370 MW YELAHANKA CAPP**  
 UF + RO1 + RO2 + MB: 312 M<sup>3</sup>/Day (Net)

|  |                    |                                                                                                                                                                                  |
|--|--------------------|----------------------------------------------------------------------------------------------------------------------------------------------------------------------------------|
|  | OWNER              | <b>KARNATAKA POWER CORPORATION LTD.</b>                                                                                                                                          |
|  | OWNER'S CONSULTANT | <b>FICHTNER Consulting Engineers (India) Private Limited, Chennai, Bengaluru.</b>                                                                                                |
|  | EPC CONTRACTOR     | <b>BHARAT HEAVY ELECTRICALS LIMITED, NEW DELHI</b><br>UNIT - BOILER AUXILIARIES PLANT : RANIPET<br>PACKAGE : UF-RO-DM<br>UF + RO-I + RO-II + MB : 312 M <sup>3</sup> / Day (Net) |

**LEGEND FOR P & ID**

| TITLE    | NAME          | SIGN. | DATE     |
|----------|---------------|-------|----------|
| DRAWN    | B B SAHU      | Sd/-  | 13.01.16 |
| CHECKED  | DBN / ATIWARI | Sd/-  | 13.01.16 |
| APPROVED | M NATRAJAN    | Sd/-  | 13.01.16 |

ALL DIMENSIONS ARE IN MILLIMETRES  
 BHHEL DRAWING NO. 2-WT-220-00211  
 SCALE N.T.S.  
 REV 01

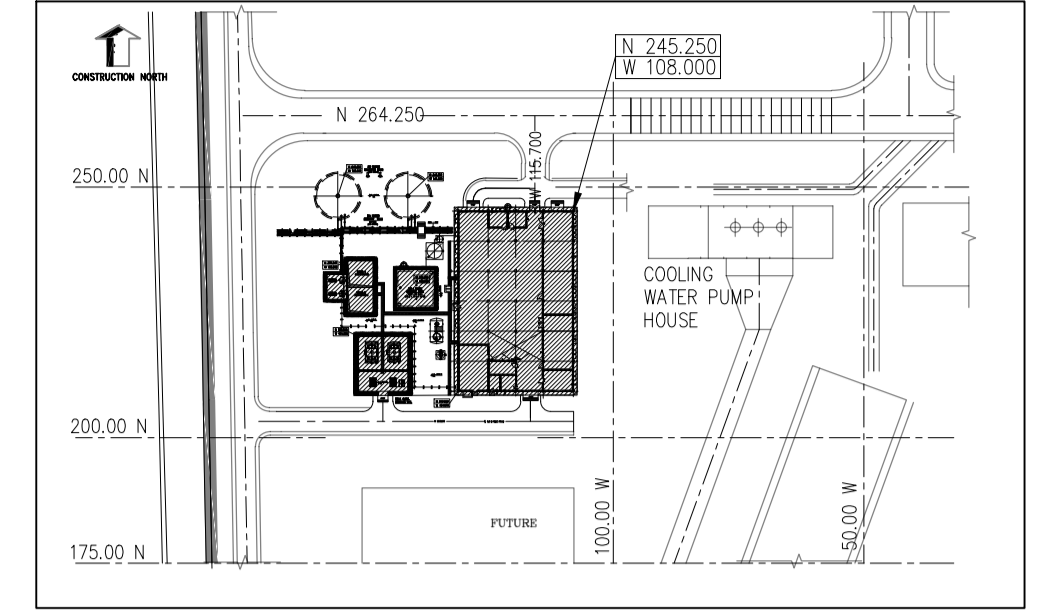
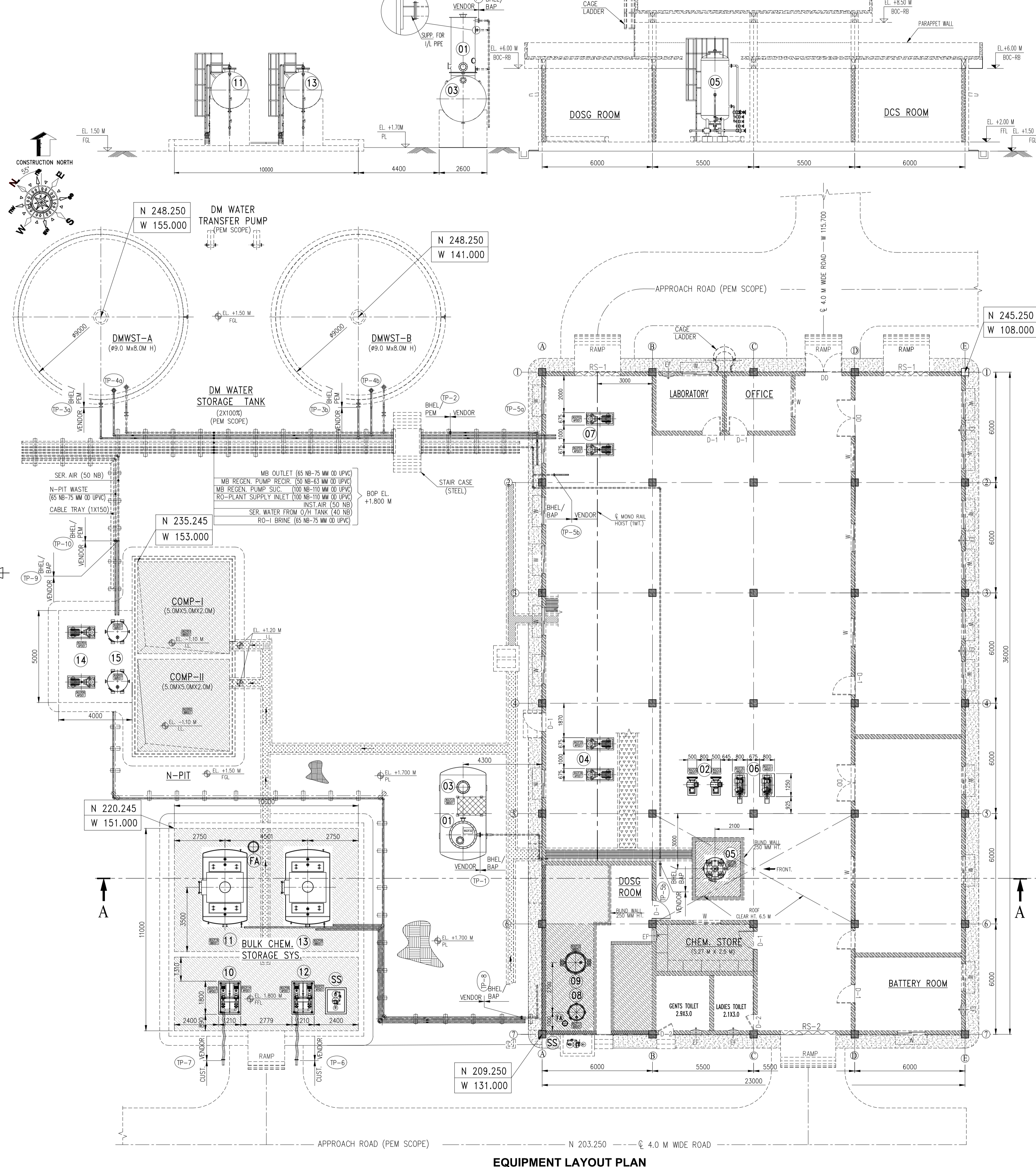

**EQUIPMENT LIST:-**

| EQPT. NO | DESCRIPTION                                    | QUANTITY | MOC    | EQPT. DIMENSION IN MTR (Approx.) | EQUIPMENT TAG NO | SHIPPING | WORKING | ZONE |
|----------|------------------------------------------------|----------|--------|----------------------------------|------------------|----------|---------|------|
| 01       | DEGASSER                                       | 1W       | MSRL   |                                  | 9GCF22           |          |         | F-4  |
| 02       | DEGASSER AIR BLOWER                            | 1W+1S    | CS     |                                  | 9GCF20-21AND01   |          |         | F-6  |
| 03       | DEGASSED WATER STORAGE TANK - 20M <sup>3</sup> | 1W       | MSRL   |                                  | 9GCF23 BB001     |          |         | F-6  |
| 04       | MB FEED PUMPS                                  | 1W+1S    | SS 316 |                                  | 9GCF25-26AP001   |          |         | F-5  |
| 05       | MIXED BED                                      | 1W       | MSRL   |                                  | 9GCF28 BB001     |          |         | F-5  |
| 06       | MB AIR BLOWER(S)                               | 1W+1S    | CS     |                                  | 9GCF30-31AND01   |          |         | F-6  |
| 07       | MB REGEN. PUMP(S)                              | 1W+1S    | SS 316 |                                  | 9GCP02-03AP001   |          |         | E-5  |
| 08       | ACID MEAS. TANK - 1 M <sup>3</sup>             | 1W       | MSRL   |                                  | 9GCP17 BB001     |          |         | C-5  |
| 09       | CAUSTIC DILUTION TANK-1M <sup>3</sup>          | 1W       | FRP    |                                  | 9GCP10 BB001     |          |         | C-5  |
| 10       | ACID UNLOAD. PUMP(S)                           | 1W+1S    | SS     |                                  | 9GCP13-14AP001   |          |         | C-2  |
| 11       | BULK ACID STORAGE TANK-15M <sup>3</sup>        | 1W       | MSRL   |                                  | 9GCP16 BB001     |          |         | C-2  |
| 12       | ALKALI UNLOAD. PUMP(S)                         | 1W+1S    | PP     |                                  | 9GCP06-07AP001   |          |         | C-3  |
| 13       | BULK ALKALI STORAGE TANK-15M <sup>3</sup>      | 1W       | MSRL   |                                  | 9GCP09 BB001     |          |         | C-3  |
| 14       | N-PIT EFFLUENT TRF. PUMP(S)                    | 1W+1S    | SS 316 |                                  | 9GR04&06AP001    |          |         | E-1  |
| 15       | PRIMG. CHAMBER-0.75M <sup>3</sup>              | 1W+1S    | CS     |                                  | 9GR03&05BB001    |          |         | E-1  |

**TERMINAL POINTS (TP)**

| TP NO. | ZONE      | DESCRIPTION                     | FLANGE SIZE | APPROX. CO-ORDINATES   | PIPE ELEVATION IN MTRS (APPROX) |
|--------|-----------|---------------------------------|-------------|------------------------|---------------------------------|
|        |           |                                 |             | NORTH/SOUTH            | EAST/WEST                       |
| TP-1   | F-4 & A-4 | DEGASSER TOWER INLET            | 50 NB       | VENDOR TO SPECIFY      | DGT I/L NOZZLE                  |
| TP-2   | D-4       | DM WATER OUTLET                 | 65 NB       | 244.950 N<br>136.000 W | +1.800 M (BOP)                  |
| TP-3a  | C-1       | MB REGEN. PUMP SUCTION          | 100 NB      | 243.550 N<br>141.000 W | +2.800 M (E)                    |
| TP-3b  | C-3       |                                 |             | 155.000 W              |                                 |
| TP-4a  | C-1       | MB REGEN. PUMP RE-CIRCULATION   | 50 NB       | DMWST ROOF             | DMWST ROOF                      |
| TP-4b  | C-3       |                                 |             |                        |                                 |
| TP-5a  | D-5       | INST. AIR SUPPLY                | 25 NB       | NEAR MB RE-GEN PUMP    | +3.500 M (E)                    |
| TP-5b  | G-5       |                                 |             | NEAR MB VESSEL         |                                 |
| TP-6   | H-3       | ALKALI UNLOADING PUMP SUC.      |             | VENDOR TO SPECIFY      | +1.800 M (BOP)                  |
| TP-7   | H-2       | ACID UNLOADING PUMP SUC.        |             | VENDOR TO SPECIFY      | +1.800 M (BOP)                  |
| TP-8   | G-4       | UTILITY WATER SUPPLY            | 50 NB       | 210.250 N<br>130.000 W | +1.800 M (BOP)                  |
| TP-9   | E-1       | SERVICE AIR INLET               | 50 NB       | 237.250 N<br>155.000 W | +1.800 M (BOP)                  |
| TP-10  | D-1       | N-PIT EFFLUENT TRF. PUMP OUTLET | 65 NB       | 458.500 N<br>134.300 E | +1.500 M (BOP)                  |

**NOTES :**

- F.F.L (FINISHED FLOOR LEVEL ) OF GT/STG BUILDING ELEVATION IS 0.00 WHICH CORRESPONDS TO RL 900.5 M.
- F.G.L (FINISHED GRADED LEVEL) OF RO-DM PLANT ELEVATION IS +1.5 M WHICH CORRESPONDS TO RL 902.0 M.
- F.F.L (FINISHED FLOOR LEVEL OF ROOM BUILDING ELEVATION IS +2.0 M WHICH CORRESPONDS TO RL 902.5 M.
- EQUIPMENT SIZES OF EQUIVALENT CAPACITY HAVE BEEN CONSIDERED. HOWEVER VENDOR SHALL PROVIDE ACTUAL DIMENSION DURING CONTRACT STAGE.
- EQPT. LOCATION DIMENSIONS AND PIPE LINE ROUTING ARE SUGGESTIVE. IT MAY BE MODIFIED DURING CONTRACT STAGE AND TO SUIT SITE CONDITION.
- ACID AND ALKALI SHALL BE TRANSFERRED FROM THE BULK STORAGE TANKS TO THE AMT/CDT BY GRAVITY.
- TERMINAL POINT (T.P.) LOCATION MARKED IN THIS DRAWING ARE TENTATIVE. FINAL LOCATION SHALL BE CONFIRMED DURING CONTRACT STAGE.
- ALL THE CIVIL FACILITIES ARE IN BHTEL SCOPE.

**LEGEND :**

- FGL - FINISHED GRADED LEVEL
- FFL - FINISHED FLOOR LEVEL
- PL - PAVED LEVEL
- RS - ROLLING SHUTTER
- DD - DOUBLE DOOR
- D - SINGLE DOOR
- EF - EXHAUST FAN
- SS - SAFETY SHOWER
- FA - FUME ABSORBER
- TBL - TANK BOTTOM SLAB LEVEL
- VENDOR SCOPE
- BHTEL SCOPE
- CHEMICAL RESISTANT TILED FLOOR
- DWARF WALL - 1.2 M HT. FROM FFL
- DRAIN CHANNEL
- AR TILED DRAIN CHANNEL
- CABLE TRENCH
- PAVEMENT
- BUND WALL
- PIPE TRENCH

**PROGRESSIVE COPY DTD. 02.05.16**  
**FOR TENDER PURPOSE ONLY**

**REFERENCE DRGS :**

- KEY PLAN : 2-WT-220-00212 REV. 00
- PLOT PLAN : PE-DG-409-100-MG01 LAT. REV.

| ZONE | REV | DATE | ALTD. | CHD. | APPD. |
|------|-----|------|-------|------|-------|
|      |     |      |       |      |       |

|                                                                                                      |                                                                                                                                                                           |                                    |                  |
|------------------------------------------------------------------------------------------------------|---------------------------------------------------------------------------------------------------------------------------------------------------------------------------|------------------------------------|------------------|
| PROJECT<br><b>1 X 370 MW YELAHANKA CAPP</b><br>UF + RO-I + RO-2 + MB : 312 M <sup>3</sup> /Day (Net) | BHARAT HEAVY ELECTRICALS LIMITED, NEW DELHI<br>UNIT : BOILER AUXILIARIES PLANT ; RANIPET<br>PACKAGE : UF-RO-DM<br>UF + RO-I + RO-II + MB : 312 M <sup>3</sup> / Day (Net) |                                    |                  |
|                                                                                                      | EPC CONTRACTOR<br>                                                                                                                                                        |                                    |                  |
| TITLE<br><b>MB SYSTEM EQPT. LAYOUT</b>                                                               | NAME<br>B B SAHU                                                                                                                                                          | SIGN.<br>Sd/-                      | DATE<br>30.04.16 |
| CHECKED<br>G RAJENDIRAN                                                                              | SIGN.<br>Sd/-                                                                                                                                                             | DATE<br>30.04.16                   |                  |
| APPROVED<br>M NATRAJAN                                                                               | SIGN.<br>Sd/-                                                                                                                                                             | DATE<br>30.04.16                   |                  |
| ALL DIMENSIONS ARE IN MILLIMETRES<br>PROJECTION<br>                                                  | SCALE<br>N.T.S                                                                                                                                                            | BHEL DRAWING NO.<br>1-WT-220-00712 | REV<br>00        |



RANIPET

## QUALITY ASSURANCE

### SURFACE PREPARATION AND PAINTING PROCEDURE FOR DESALINATION COMPONENTS

PRQA: 526

REVISION: 01

DATE: 14.08.01

PAGE: 1 OF 5

|                         |                    |                                                                                          |                  |
|-------------------------|--------------------|------------------------------------------------------------------------------------------|------------------|
| <b>PROCEDURE FOR</b>    |                    | <b>SURFACE PREPARATION<br/>AND PAINTING OF<br/>COMPONENTS OF<br/>DESALINATION PLANTS</b> |                  |
| <b>EFFECTIVE DATE</b>   |                    | 14.08.2001                                                                               |                  |
| <b>PREPARED BY</b>      | <b>NAME</b>        | <b>DEPARTMENT</b>                                                                        | <b>SIGNATURE</b> |
|                         | K.RAJADURAI        | QA                                                                                       |                  |
| <b>REVIEWED BY</b>      | B.SRINIVASA RAO    | QA                                                                                       |                  |
|                         | M.NATARAJAN        | EDC/DCI                                                                                  |                  |
|                         | M.RAVINDRA         | MSA                                                                                      |                  |
|                         | P.RAJASEKARAN      | QC/OLI                                                                                   |                  |
| <b>APPROVED BY</b>      | H.ANANTHANARAYANAN | QA                                                                                       |                  |
| <b>REVISION NO.</b>     |                    | 01                                                                                       |                  |
| <b>ISSUED BY</b>        |                    | QUALITY ASSURANCE                                                                        |                  |
| <b>CONTROL COPY NO.</b> |                    |                                                                                          |                  |
| <b>ISSUED TO SHRI.</b>  |                    |                                                                                          |                  |



RANIPET

## QUALITY ASSURANCE

### SURFACE PREPARATION AND PAINTING PROCEDURE FOR DESALINATION COMPONENTS

PRQA: 526

REVISION: 01

DATE: 14.08.01

PAGE: 2 OF 5

## RECORD OF REVISIONS

| REVISION NO. | DETAILS OF ISSUE     | DATE OF ISSUE |
|--------------|----------------------|---------------|
| 00           | ORIGINAL ISSUE       | 09.05.96      |
| 01           | EDITORIAL CORRECTION | 14.08.01      |

|                                                                                                  |                                                                                                                                     |                                                                                                            |
|--------------------------------------------------------------------------------------------------|-------------------------------------------------------------------------------------------------------------------------------------|------------------------------------------------------------------------------------------------------------|
|  <p>RANIPET</p> | <p><b><u>QUALITY ASSURANCE</u></b></p> <p><b>SURFACE PREPARATION AND PAINTING<br/>PROCEDURE FOR DESALINATION<br/>COMPONENTS</b></p> | <p><b>PRQA: 526</b></p> <p><b>REVISION: 01</b></p> <p><b>DATE: 14.08.01</b></p> <p><b>PAGE: 3 OF 5</b></p> |
|--------------------------------------------------------------------------------------------------|-------------------------------------------------------------------------------------------------------------------------------------|------------------------------------------------------------------------------------------------------------|

**PROCEDURE FOR SURFACE PREPARATION AND PAINTING OF  
COMPONENTS OF DESALINATION PLANTS**

**1.0 SCOPE:**

This procedure gives guidelines for surface preparation and painting of components of Desalination Plants.

**2.0 The following are not under the purview of this procedure.**

2.1 Masonry structures, PVC tubes, pipes & fittings, FRP vessels, pipes components and glass.

**3.0 PROCEDURE:**

3.1 The following components of Desalination Plants are under the purview of this procedure.

- (a) Membrane Racks
- (b) Valve supports and clamps, Pipe supports and clamps
- (c) Supporting Structures
- (d) Carbon steel filters, hand rails, platforms
- (e) Shed Structures
- (f) Handling Equipment
- (g) Cranes
- (h) Electric motors, base frame
- (i) Any other component specified in the drawings.

**4.0 SURFACE PREPARATION SCHEME:**

4.1 Except stainless steel pipes and fittings (and Aluminium if any) all other steel surfaces shall be sand / shot blasted to SA 2½ finish as per Swedish Standard SIS 055900 before painting.

|                                                                                   |                                                                                       |                                                |
|-----------------------------------------------------------------------------------|---------------------------------------------------------------------------------------|------------------------------------------------|
|  | <b>QUALITY ASSURANCE</b>                                                              | PRQA: 526                                      |
|                                                                                   | <b>SURFACE PREPARATION AND PAINTING<br/>PROCEDURE FOR DESALINATION<br/>COMPONENTS</b> | REVISION: 01<br>DATE: 14.08.01<br>PAGE: 4 OF 5 |

## 5.0 PAINTING SCHEME:

See Table – 1 below.

TABLE – 1

| Scheme | Paint Type                        |
|--------|-----------------------------------|
| PS 1   | Epoxy Zinc Phosphate Primer Paint |
| PS 2   | Epoxy finish Paint                |

5.1 The probable paint supplier can be as follows:

- a. Asian Paint (India) Ltd.
- b. Bombay Paints
- c. Berger paints India Ltd.
- d. Goodlass Nerolac paints Ltd.
- e. Garware Paints
- f. Jenson & Nicholson
- g. Shalimar paints

| Sl. No | Component                             | Surface Preparation                                         | Primer | No. of Coats | DFT Total Microns | Finish Paint | No. of Coats | DFT Total Microns |
|--------|---------------------------------------|-------------------------------------------------------------|--------|--------------|-------------------|--------------|--------------|-------------------|
| 01     | Membrane Racks                        | SA 2 ½                                                      | PS 1   | 2            | 100               | PS 2         | 2            | 100               |
| 02     | Valve Supports and Clamps             | SA 2 ½                                                      | PS 1   | 2            | 100               | PS 2         | 2            | 100               |
| 03     | Supporting Structures                 | SA 2 ½                                                      | PS 1   | 2            | 100               | PS 2         | 2            | 100               |
| 04     | Carbon steel filters (outer surfaces) | SA 2 ½                                                      | PS 1   | 2            | 100               | PS 2         | 2            | 100               |
| 05     | Hand Rails & Platforms                | SA 2 ½                                                      | PS 1   | 2            | 100               | PS 2         | 2            | 100               |
| 06     | Shed Structures & Clamps              | SA 2 ½                                                      | PS 1   | 2            | 100               | PS 2         | 2            | 100               |
| 07     | Handling Equipment                    | Leave greased/oiled surfaces free (for other follow scheme) | PS 1   | 2            | 100               | PS 2         | 2            | 100               |
| 08     | Cranes                                | - do -                                                      | PS 1   | 2            | 100               | PS 2         | 2            | 100               |

|                                                                                                  |                                                                                                                                     |                                                                                                            |
|--------------------------------------------------------------------------------------------------|-------------------------------------------------------------------------------------------------------------------------------------|------------------------------------------------------------------------------------------------------------|
|  <p>RANIPET</p> | <p><b><u>QUALITY ASSURANCE</u></b></p> <p><b>SURFACE PREPARATION AND PAINTING<br/>PROCEDURE FOR DESALINATION<br/>COMPONENTS</b></p> | <p><b>PRQA: 526</b></p> <p><b>REVISION: 01</b></p> <p><b>DATE: 14.08.01</b></p> <p><b>PAGE: 5 OF 5</b></p> |
|--------------------------------------------------------------------------------------------------|-------------------------------------------------------------------------------------------------------------------------------------|------------------------------------------------------------------------------------------------------------|

**6.0 GENERAL PRECAUTIONS:**

- 6.1 Do not delay painting after Sand / Shot blasting. Maximum delay permitted is only half an hour.
- 6.2 Do not paint when the weather is rainy or the temperature is below 20<sup>0</sup> C.
- 6.3 The epoxy primer and finished paints are two component paints. The components must be mixed in the proportions given by the manufacturer only. The application of epoxy paints shall be completed with in 2 hours of mixing.
- 6.4 The etch/wash primers are also two component paints, which must be mixed in proportions given by the manufacturer.

**7.0 IMPORTANT:**

If the components are to be painted at site one coat of EPOXY FINISH PAINT of DFT 50 Microns SHALL BE GIVEN.

## Annexure-B

**MANDATORY SPARES for MB system (Ref. Matl. Code RWT603930021 & Spec. ROS: 6154 & ROS:4140)**

### (A). Mechanical System

| Sl. No. | Description of the equipment | Description of spares   | Qty                                     | Unit                                                    |
|---------|------------------------------|-------------------------|-----------------------------------------|---------------------------------------------------------|
| 01      | Degasser tower               | Pall rings              | 10% of total quantity                   |                                                         |
|         |                              | Fill support members    | 10% of total quantity                   |                                                         |
|         |                              | Water sealing fittings  | 10% of total quantity                   |                                                         |
| 02      | Degasser blower              | Blades/Impeller         | 2                                       | set                                                     |
|         |                              | Shaft                   | 2                                       | Set                                                     |
|         |                              | Blower bearings         | 2                                       | set                                                     |
| 03      | Mixed Bed unit               | Resin                   | 10% of total quantity<br>cation & anion | Min. 40 ltrs<br>cation &<br>Min. 70 ltrs<br>Anion resin |
|         |                              | Laterals                | 10% of total quantity                   |                                                         |
|         |                              | Strainers/Filter nozzle | 10% of total quantity                   |                                                         |
| 04      | Acid unloading pump          | Impeller                | 1                                       | No                                                      |
|         |                              | Shafts                  | 1                                       | No                                                      |
|         |                              | Bearings                | 1                                       | Set                                                     |
|         |                              | Shaft sleeves           | 1                                       | Set                                                     |
|         |                              | Bearing bushings        | 1                                       | Set                                                     |
|         |                              | Mechanical seal         | 1                                       | Set                                                     |
|         |                              | Wearing rings           | 1                                       | Set                                                     |
|         |                              | Fasteners               | 1                                       | set                                                     |
| 05      | Alkali unloading pumps       | Impeller                | 1                                       | No                                                      |
|         |                              | Shafts                  | 1                                       | No                                                      |
|         |                              | Bearings                | 1                                       | Sets                                                    |
|         |                              | Shaft sleeves           | 1                                       | Sets                                                    |
|         |                              | Bearing bushings        | 1                                       | Sets                                                    |
|         |                              | Mechanical seal         | 1                                       | Set                                                     |
|         |                              | Wearing rings           | 1                                       | Sets                                                    |
|         |                              | Fasteners               | 1                                       | sets                                                    |
| 06      | Neutralizing system pumps    | Impeller                | 1                                       | No                                                      |
|         |                              | Shafts                  | 1                                       | No                                                      |
|         |                              | Bearings                | 1                                       | Sets                                                    |
|         |                              | Shaft sleeves           | 1                                       | Sets                                                    |
|         |                              | Bearing bushings        | 1                                       | Sets                                                    |
|         |                              | Mechanical seal         | 1                                       | Set                                                     |
|         |                              | Wearing rings           | 1                                       | Sets                                                    |
|         |                              | Fasteners               | 1                                       | sets                                                    |
| 07      | DM Regeneration pump         | Impeller                | 1                                       | No                                                      |
|         |                              | Shafts                  | 1                                       | No                                                      |
|         |                              | Bearings                | 1                                       | Sets                                                    |
|         |                              | Shaft sleeves           | 1                                       | Sets                                                    |
|         |                              | Bearing bushings        | 1                                       | Sets                                                    |

|    |                      |                  |   |      |
|----|----------------------|------------------|---|------|
|    |                      | Mechanical seal  | 1 | Set  |
|    |                      | Wearing rings    | 1 | Sets |
|    |                      | Fasteners        | 1 | sets |
| 08 | Mixed Bed Feed pumps | Impeller         | 1 | No   |
|    |                      | Shafts           | 1 | No   |
|    |                      | Bearings         | 1 | Sets |
|    |                      | Shaft sleeves    | 1 | Sets |
|    |                      | Bearing bushings | 1 | Sets |
|    |                      | Mechanical seal  | 1 | Set  |
|    |                      | Wearing rings    | 1 | Sets |
|    |                      | Fasteners        | 1 | sets |

**(B). E C&I system**

| Sl no | Description                                        | Quantity | Unit |
|-------|----------------------------------------------------|----------|------|
| 1     | Air filter regulator                               | 1        | No   |
| 2     | Pressure Indicating transmitter (PIT)              | 1        | No   |
| 3     | Level transmitter                                  | 1        | No   |
| 4     | Flow Indicating Transmitter (FIT) & orifice plates | 1        | No   |
| 5     | Differential Pressure Switch (DPS)                 | 1        | No   |
| 6     | Conductivity Analyser (complete set with sensor).  | 1        | No   |
| 7     | PH Analyser (complete set with sensor).            | 1        | No   |
| 8     | pH sensor (additional)                             | 1        | No   |



## BHEL : BAP : RANIPET New Products

### QUALIFICATION REQUIREMENT FOR WORKING MIXED BED (MB) SYSTEM / DEMINERALIZATION (DM) PLANT

The Qualification requirements for working Mixed Bed (MB) System / Demineralization Plant are listed below and Vendors should meet the same:

1. Should have experience in design, manufacture, supply, erection , commissioning & successful operation of either one of the following system (working MB or DM System consisting of SAC, SBA & MB) with consistent output parameters meeting the quality requirement of DM water :

| Sl. No. | Description                     | In case of Working MB  | In case of DM (SAC, SBA & MB) |
|---------|---------------------------------|------------------------|-------------------------------|
| i       | Minimum Net capacity per stream | 20 m <sup>3</sup> /hr. | 20 m <sup>3</sup> /hr.        |
| ii      | Minimum TDS of input water      | 10 mg/lit              | 30mg/lit                      |

2. MB / DM unit (referred by the vendor under Sl. No. 1 shall be capable of producing DM water to be used as make-up feed water to Boiler /Steam generator with the net output between regeneration (OBR) on continuous operation basis as 72 hours (minimum).
3. Mixed Bed / DM plant outlet water quality should fulfill the following requirements:

| Sl. No. | Description                | Unit  | Values     |
|---------|----------------------------|-------|------------|
| i       | Conductivity at 25 deg. c  | μS/cm | 0.10 max   |
| ii      | Silica as SiO <sub>2</sub> | ppm   | 0.015 max  |
| iii     | pH                         |       | 6.8 to 7.2 |

4. Plant (referred by the vendor under Sl. No. 1) should have been in trouble free operation for a period of minimum one year after successful commissioning as on 1<sup>st</sup> Apr 2016.
5. Plant should have been in auto mode operation & regeneration through PLC or DCS system.
6. Vendor shall furnish necessary documentary evidence in original / attested copy obtained from the customer as a proof of meeting the qualifying criteria for review by BHEL. The certificate shall contain all required information for the satisfactory performance, such as plant capacity, location of the plant with postal address, date of supply & commissioning, design and actual performance parameters, etc., Original certificate shall be provided to BHEL for verification, whenever required by BHEL.
7. Vendor shall fill up all relevant information of the plant already executed by them (refer to Sl. No. 1) in the enclosed format (Annexure I & II) and submit the signed format.
8. Vendors who defaulted, in any of the previous tenders floated by BHEL are not permitted to participate in this tender.
9. Final acceptance of offer is subject to the approval of end customer.
10. After receipt of offers, during scrutiny any vendor found to be banned by BHEL, then their offer will be summarily rejected at any stage.

**Annexure - I**  
**QUALIFICATION DATA SHEET - WORKING MB**

**A. Customer details:-**

- a. Name :  
b. Designation :  
c. Mobile :  
d. Land line :  
e. Fax :  
f. Email id :  
g. Postal address :

**B. Plant Details:-**

Date of Supply :

Date of commissioning:

| Sl. No. | Parameters                                                                                                                                      | Unit                         | Design | Actual |
|---------|-------------------------------------------------------------------------------------------------------------------------------------------------|------------------------------|--------|--------|
| 01      | Mixed Bed capacity                                                                                                                              | m <sup>3</sup> /hr.          |        |        |
| 02      | Output between regeneration (OBR)                                                                                                               | m <sup>3</sup>               |        |        |
| 03      | Type of operation                                                                                                                               | Automatic through PLC or DCS |        |        |
| 04      | Feed water quality<br>a. pH<br>b. Conductivity<br>c. SiO <sub>2</sub>                                                                           | μS/cm<br>ppm                 |        |        |
| 05      | Output water quality<br>a. pH<br>b. Conductivity<br>c. TDS<br>d. SiO <sub>2</sub>                                                               | μS/cm<br>ppm<br>ppm          |        |        |
| 06      | MB Vessel size Diameter x Height per stream                                                                                                     | m                            |        |        |
| 07      | Cation Resin used<br>a. Make<br>b. Type<br>c. Quantity                                                                                          | Litres                       |        |        |
| 08      | Anion Resin used<br>a. Make<br>b. Type<br>c. Quantity                                                                                           | Litres                       |        |        |
| 09      | Chemical consumption per regeneration as 100% basis<br>a. Hydrochloric acid for Cation regeneration<br>b. Sodium Hydroxide for Anion generation | Kg<br>kg                     |        |        |
| 10      | Duration of regeneration<br>a. Cation<br>b. Anion                                                                                               | Hrs.<br>Hrs.                 |        |        |

**Signature of the Vendor**

**Annexure - II**  
**QUALIFICATION DATA SHEET**  
**DM (SAC, DG, SBA & MB) SYSTEM**

**A. Customer details:-**

- a. Name :  
b. Designation :  
c. Mobile :  
d. Land line :  
e. Fax :  
f. Email id :  
g. Postal address :

**B. Plant Details:-**

Date of Supply :

Date of commissioning:

| Sl. No. | Parameters                                                                        | Unit                         | Design | Actual |
|---------|-----------------------------------------------------------------------------------|------------------------------|--------|--------|
| 01      | DM Plant Capacity                                                                 | m <sup>3</sup> /hr.          |        |        |
| 02      | Output between regeneration (OBR)                                                 | m <sup>3</sup>               |        |        |
| 03      | Type of operation                                                                 | Automatic through PLC or DCS |        |        |
| 04      | Feed water quality<br>a. pH<br>b. Conductivity<br>c. SiO <sub>2</sub>             | μS/cm<br>ppm                 |        |        |
| 05      | Output water quality<br>a. pH<br>b. Conductivity<br>c. TDS<br>d. SiO <sub>2</sub> | μS/cm<br>ppm<br>ppm          |        |        |
| 06      | SAC Vessel Size Diameter x Height per stream                                      | m                            |        |        |
|         | DGT Vessel size Diameter x Height per stream                                      | m                            |        |        |
|         | SBA Vessel size Diameter x Height per stream                                      | m                            |        |        |
|         | MB Vessel Size Diameter x Height per stream                                       | m                            |        |        |
| 07      | Cation Resin used in SAC<br>a. Make<br>b. Type<br>c. Quantity                     | Litres                       |        |        |
| 08      | Anion Resin used in SBA<br>a. Make<br>b. Type<br>c. Quantity                      | Litres                       |        |        |
| 09      | Cation Resin used in MBC<br>d. Make<br>e. Type<br>f. Quantity                     | Litres                       |        |        |

**Annexure - II**  
**QUALIFICATION DATA SHEET**  
**DM (SAC, DG, SBA & MB) SYSTEM**

| Sl. No. | Parameters                                                                                                                                             | Unit         | Design | Actual |
|---------|--------------------------------------------------------------------------------------------------------------------------------------------------------|--------------|--------|--------|
| 10      | Anion Resin used in MB<br>d. Make<br>e. Type<br>f. Quantity                                                                                            | Litres       |        |        |
| 11      | Chemical consumption for SAC per regeneration as 100% basis<br>a. Hydrochloric acid                                                                    | Kg           |        |        |
| 12      | Duration of regeneration                                                                                                                               | Hrs.         |        |        |
| 13      | Chemical consumption for SBA per regeneration as 100% basis<br>b. Sodium Hydroxide                                                                     |              |        |        |
| 14      | Duration of regeneration                                                                                                                               | Hrs.         |        |        |
| 15      | Chemical consumption for MB per regeneration as 100% basis<br>c. Hydrochloric acid for Cation regeneration<br>d. Sodium Hydroxide for Anion generation | Kg<br>kg     |        |        |
| 16      | Duration of regeneration<br>a. Cation<br>b. Anion                                                                                                      | Hrs.<br>Hrs. |        |        |

**Signature of the Vendor**