

By Courier/Regd. Post/Speed Post

	TENDER ENQUIRY (Supplier's Copy)	Enquiry no. & Date	Due date for Quotation
To,		15E0082	03.11.2015
M/s		Bharat Heavy Electricals Ltd. (A Govt. of India Under Taking) Rudrapur - 263153 Distt. Udham Singh Nagar (Uttarakhand) India Phone no.- 05944-241400/242326 Fax no. 05944-243605 e-mail: shilanand@bhel.in manohar@bhel.in	
Limited Tender Enquiry 15E0082 dated: 19.10.2015 due on 03.11.2015			

Sl.No.	Description	Unit	Req. Qty.	Delivery Schedule
1.	ANNUAL FRAMEWORK AGREEMENT for FABRICATION & PAINTING OF MAKE UP PIECES (PLAIN TYPE) on Job Work Basis MAJOR TERMS of this tender is as per annexure-1 enclosed. PRICE BID of this tender is as per annexure-2 enclosed. LD CLAUSE and RISK PURCHASE CLAUSE are applicable in this tender.	Kg.	50,000	Within 01 month from the date of receipt of Raw material or as per individual PO.

Dear Sir,

Please submit your lowest quotation, subject to our terms and conditions written overleaf for the above mentioned items so as to reach us on or before the due date by 2.00 P.M.

Enquiry No. & Due Date should be superscribed on the envelope containing the quotation

FOR BHARAT HEAVY ELECTRICALS LTD.
(SIGN. & NAME)



SHYAM BIHARI JAISWAL
ENGINEER-MM

एस० बी० जायसवाल S.B. Jaiswal
अभि. (सामग्री प्रबंधन) Engg.(Mat. Mang.)
सी. एच. ई. एल. - रुद्रपुर BHEL-Rudrapur
उत्तराखण्ड-263153 Uttarakhand-263153

TERMS AND CONDITIONS

- 1- **SUBMISSION OF TENDER.** Quotation must be enclosed in a sealed cover, duly superscribed & addressed as
Due on...03.11.2015..... Enq. No...15E0082.....
TO,
THE MANAGER (MM)
BHARAT HEAVY ELECTRICALS LTD.
COMPONENT FABRICATION PLANT
RUDRAPUR, DISTT. UDHAM SINGH NAGAR (UTTARAKHAND) - 263153
TEL :05944-242326
- 1- The quotation must be posted with due date allowance for postal delay. Alternatively the tender duly sealed and superscribed may be deposited in the tender box placed in the office of the undersigned.
ANY TENDER NOT SUBMITTED IN THIS MANNER IS LIKELY TO BE IGNORED.
- 2- **OPENING :** All tender must reach this office/deposited in the tender box before 2 P.M. The tender will be opened on the due date at 3 P.M. in the Office of the undersigned in the persence of tenderer who may like to be present.
LATE & DELAYED TENDER WILL BE REJECTED
- 3- Prices should be quoted for delivery on F.O.R. basis or Ex-Godown basis. Ex-Godown rates must include packing and forwarding charges if applicable extra. Please indicate percentage. The prices should be as per DGS & D rate contract if any held currently by the tenderer.
A copy of rate contract, should be enclosed. If there is no rate contract. lowest price applicable to DGS & D and other Government should be quoted and a certificate to this effect must be incorporated in the quotation.
The prices quoted must be exclusive of sales tax, excise duty etc. The rates at which these taxes are applicable must be seperately mentioned, If not mentioned. it will be presumed that prices quoted are inclusive of these charges and no other charges will be entertained later on.
- 4- **DELIVERY :** The supplier must mention the delivery period clearly. If the delivery is not completed within the prescribed time specified in the order, supplier shall be liable to unconditional penalty of 1/2% per week subject to 10% max.
For material not supplied in time and/or confirming to specifications, the Purchaser shall have the descretion to resort to purchase from elsewhere on the risk and cost of the supplier without any notice.
- 5- **PENALTY :** Orders placed against this enquiry will be subject to imposition of penalty/liquidated damages, risk purchases, cancellation, arbitration as per the terms of purchase order in case of dealy in effecting supply or other default as mentioned in clause 4.
- 6- **TERNS OF PAYMENT :** Our standard payment terms are "100% after receipt, subject to acceptance at our end in 45 days.
- 7- **SPECIFICATION :** The good supplied must conform to required specifications. For the standard products, the trade mark etc. must be stated in the offer. Complete illustrative technical literature/Catalouge/drawing should be attached with the offer, falling which, same may be ignored. The prices must be quoted only in the units mentioned, Original T.C. from the manufacturer Govt. approved. Test house will have to be produced. The goods/ equipment shall have to be guaranteed against all defects for a period of 12 months from the date of acceptance/ and at their risk.
- 8- **SAMPLE :** Whenever demanded/necessary, parties may submit samples before the tender opening or alongwith the quotation, The samples should be properly tagged indicating the supplier's name, enquiry No. and due date, against which the supplier's name is to be considered. Rejected samples must be replaced within 15 days of our intimation, failling which the same will be destroyed.
- 9- **TESTIMONIALS :** Income tax clearance certificates and other testimonial from bank or other authorities may be called by us wherever neccessary.
- 10- **QUANTITIES :** All the quantities in the enquiry may not be ordered, Supplier should be prepared to accept orders for reduced quantities without any extra charges.
- 11- **VALIDITY :** All quotation should be valid for acceptance for 3 months from the date of opening.
- 12- Bharat Heavy Electricals Ltd., Rudrapur Distt. Udhm Singh Nagar reserves the right to reject any or all tenders without assigning any reason there of.

QUOTATIONS NOT IN ACCORDANCE WITH THE ABOVE INSTRUCTIONS AND CONDITIONS MAY BE DISQUALIFIED

**Annexure-1 (MAJOR TERMS) to Tender Enquiry for MAKE UP PIECES:
Tender Enquiry: 15E0082 dated: 19.10.2015 due on 03.11.2015**

- Rates are to be quoted for entering into annual frame work agreement for 1 year duration. Rates quoted should therefore be firm & valid for 1 year.
- Rates have to be quoted FOR BHEL Rudrapur basis only. (To and Fro charges shall be in the sope of subcontractor) with 100% payment after receipt of material within 45 days subject to acceptance. Any deviation in payment terms will be loaded @ (SBI PLR at the time of payment loading +6) % annual interest for comparing standing.
- Validity of the quotation must be 3 months from the date of quotation.
- Delivery of the material within 1 month from the date of receipt of Raw Material by subcontractor or as per the individual PO.
- 15 days notice period shall be given for inviting offers.
- Offers shall be submitted in double bid system i.e. in two separate envelopes supescribed as (I) Technical bid containing technical offer alongwith Commercial Term and conditions + un-priced copy of the price bid only (II) Price bid containing only price of the items.

BHEL reserves the following rights:

- I. To finalize the tender with one or more than one bidders limited to 03 bidders.

DISTRIBUTION OF TENDER QUANTITY (%)			
Slab	L-1	L-2	L-3
03 bidders	50	30	20
02 bidders	60	40	
1 bidder	100		

- II. Systematic counter offering shall follows to finalize the tender.
 - III. To go for Reverse Auction instead of Price Bid Opening after techno-commercial evaluation.
 - IV. To accept / reject any / all tenders or part thereof without assigning any reason thereof.
 - V. To turminate the F/A by giving a notice of 15 days if the performance of the party is not found to be satisfactory.
- Vendor to confirm the major terms & conditions and submit the signed & stamped copy of the same. Sample drawings are enclosed.
 - Inspection shall be done at vendor's work by BHEL/Customer/Third party inspection agency.
 - Late offers shall not be considered even if posted by Speed / Regd. Post before due date.
 - For terms & conditions other than mentioned here, the bidders should go through the terms & conditions mentioned on the reverse of Enquiry format before submitting their offers.
 - Required Raw Material of Al. Sheet/Plate shall be provided by BHEL Rudrapur.
 - Burning Allowance will be applicable 2% of the drawing weight. Scrap shall be returned to BHEL.
 - For inside, Black Matt Paint to be done & for outer surface, Paint Shade shall be as per our project requirement.
 - Paint thickness will be 65 Micron min. and adhesion test must be ok.
 - All make up pieces should be properly identifiable with Project Name,PO NO & PO SL. NO., BOM NO, DRG NO & It NO as per individual POs & drawing requirements.
 - Dimension Report / Inspection Report must be provided by vendor with each consignment.
 - Rates shall be quoted on per kgs. basis only.



एस० बा० जायसवाल S.B. Jaiswal
अभि. (सागरी प्रबंधन) Engg. (Mat. Mangl)
बी.एच.ई.एल.-रुद्रपुर BHEL-Rudrapur
उत्तराखण्ड-263153 Uttarakhand-263153

Bidder's Sign & Seal:

Annexure-2 (PRICE BID) to Tender Enquiry for MAKE UP PIECES:

Tender Enquiry:15E0082 dated: 19.10.2015 due on: 03.11.15

SL NO	ITEM	UNIT	QUANTITY	LANDED RATE (Rs. /UNIT)
1	Make Up Pieces (Plain Type)	Kg.	50,000	QUOTE

Note:- Rate shall be quoted on per Kg. basis only.

Bidder's Sign & Seal:

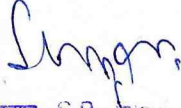

एस० बी० जायसवाल S.B. Jaiswal.
अभि. (सामग्री प्रबंधन) Engg. (Mat. Mang.)
बी.एच.ई.एल.-रुद्रपुर BHEL-Rudrapur
उत्तराखण्ड-263153 Uttarakhand-263153

FIRST ANGLE PROJECTION

(ALL DIMENSIONS IN mm)

35 37 11 11 097

DRAWING NO.

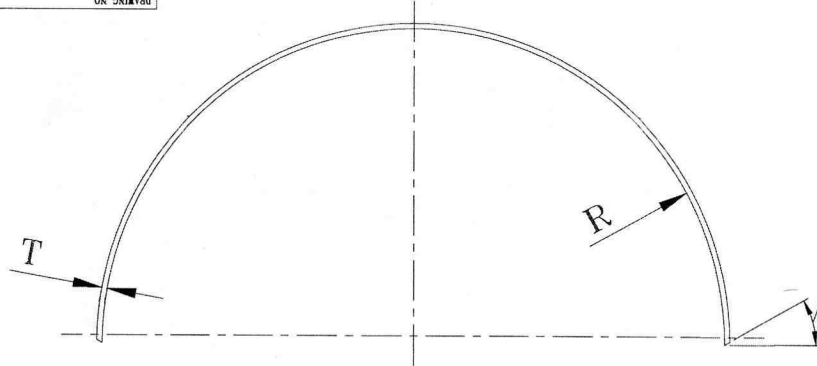

CHAMFER 6X35°,
ONLY FOR 8 & 9TK.
(BOTH SIDE)

FOR SAMPLE

ITEM NO. 001 TO 012

NOTE:

1) LENGTH "L" OF SHEET TO BE TAKEN AS MENTION (i.e. IS TAKEN AS MINIMUM 25 mm EXTRA TO MAINTAIN THE ACTUAL GAP AT SITE).

DEVELOPED LENGTH BEFORE
ROLLING = L

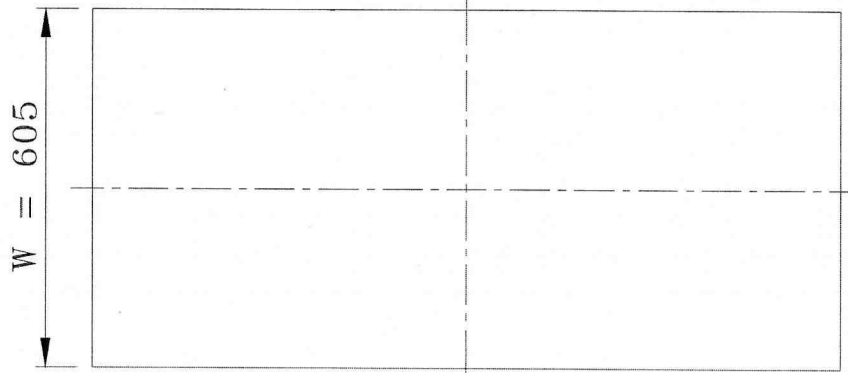

DEVELOPMENT OF ITEM
NO. 001 TO 013

VAR. NO.	REMARKS	ITEM NO.	W	L	T	R	DESCRIPTION	DRAWING NO.	IT. NO. VAR.	MATL. CODE MATL. SPCN.	WT. QTY.
--	ROLL TO ø1200	013	605	1923	LG	6.35	600	SEE DETAIL			19.94
--	ROLL TO ø1700	012	605	2710	LG	9.00	850	SEE DETAIL			39.84
--	ROLL TO ø1000	011	605	1609	LG	6.35	500	SEE DETAIL			16.68
--	ROLL TO ø1070	010	605	1719	LG	6.35	535	SEE DETAIL			17.83
--	ROLL TO ø878	009	605	1411	LG	4.78	438	SEE DETAIL			11.02
--	ROLL TO ø1600	008	605	2551	LG	8.00	800	SEE DETAIL			33.25
--	ROLL TO ø1500	007	605	2393	LG	8.00	750	SEE DETAIL			31.17
--	ROLL TO ø1200	006	605	1923	LG	8.00	600	SEE DETAIL			24.99
--	ROLL TO ø1070	005	605	1719	LG	8.00	535	SEE DETAIL			22.30
--	ROLL TO ø1000	004	605	1609	LG	8.00	500	SEE DETAIL			20.85
--	ROLL TO ø878	003	605	1411	LG	6.35	438	SEE DETAIL			14.48
--	ROLL TO ø780	002	605	1258	LG	4.78	390	SEE DETAIL			9.70
--	ROLL TO ø680	001	605	1101	LG	4.78	340	SEE DETAIL			6.46

CUSTOMER:		BHARAT HEAVY ELECTRICALS LIMITED RUDRAPUR				PROJECT: GENERAL	
DRN.	NAME	SIGN.	DATE	NO. OF VAR.			
CKD.	S.K. GUPTA						
APPD.	R.K. SAXENA						
DEPTT.	UNTOLDIM.GR.	SCALE	WEIGHT-KG	REF. TO ASSY.DRG.	IT.NO.	NO. OF ITEM	
E/D	C/M/F	⊕					
TITLE				DRAWING NO.		REV.	
AL. ALLOY MAKE UP PIECES AS PER DESCRIPTION				35 37 11 11 097		03	
SHEET NO.- 01		NO. OF SHEETS- 01		SIZE- A3			

COPYRIGHT & CONFIDENTIAL. IT IS FORWARDED TO YOU AS A SERVICE OF BHARAT HEAVY ELECTRICALS LIMITED. ALL RIGHTS RESERVED TO THE COMPANY.

एस. बी. जैसवाल S.B. Jaiswal
अभि. (सामग्री प्रबंधन) Engg. (Met/Mang)
की. एच. ई. एस. - रुद्रपुर BHEL-Rudrapur
बताराखण्ड-263153 Uttarakhand-263153

REV.	DATE	ALTERED	REV.	DATE	ALTERED	REV.	DATE	ALTERED
03	29.08.14	CHEKED	02	11.12.13	CHEKED	01	23.07.12	CHEKED
1. ITEM-012 ADDED.			1. ITEM-011 ADDED.			1. ITEM-009 & 010 ADDED. 2. DIM. 'L' CHANGE FOR ITEM-001 TO DOR.		

CAD FILE NAME:

FIRST ANGLE PROJECTION

(ALL DIMENSIONS IN mm)

31211400001
DRAWING NO.

6

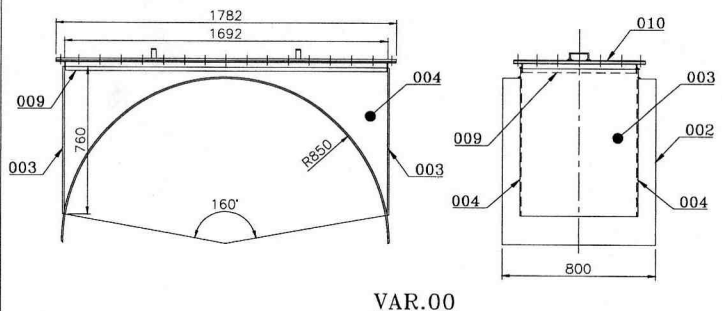

VAR.00

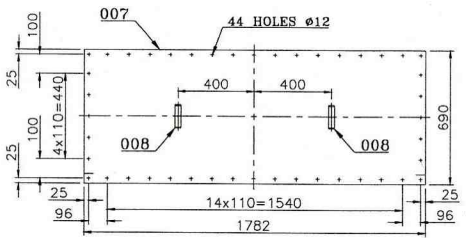

VAR.02

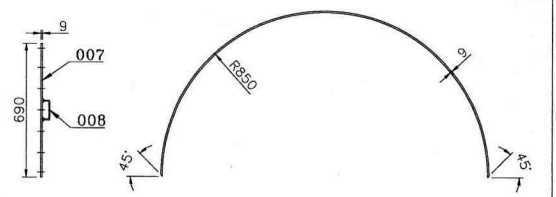

IT-001 & 002

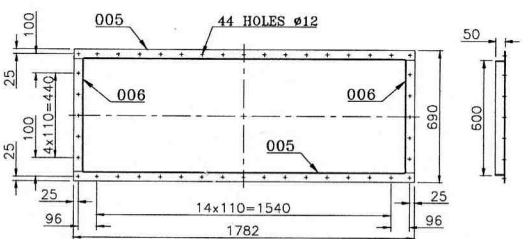

VAR.01

FOR SAMPLE

WT. FOR VAR.00=94.091 KG.

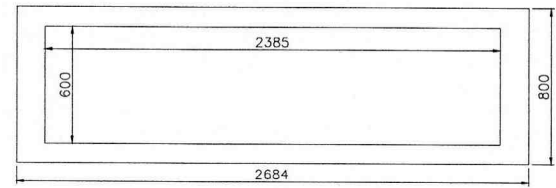

IT-002

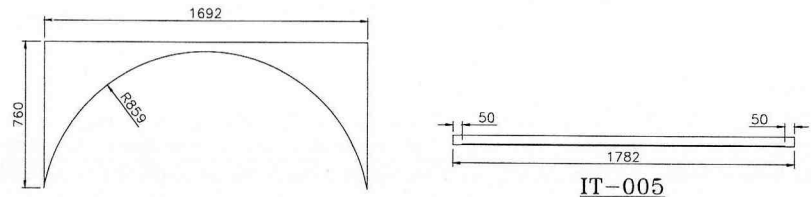

IT-004

IT-005

COPYRIGHT & CONFIDENTIAL THE INFORMATION ON THIS DOCUMENT IS THE PROPERTY OF BHARAT HEAVY ELECTRICALS LIMITED. IT MUST NOT BE USED DIRECTLY OR INDIRECTLY IN ANY MANNER TO THE DISEMPOWERMENT OF THE COMPANY.

AS REQD.	SEE DETAIL	ITEM NO.	DESCRIPTION	DRAWING NO.	IT.NO. VAR.	MATL.CODE	MATL.SPCN.	WT. QTY.	U
015	GASKET 6 TK.	015						001	
044	SPRING WASHER ST. M10	014						001	
088	PUNCHD WASHER ST. M10	013						001	
044	HEX. HD. NUT ST. M10	012						001	
044	HEX. HD. SCREW ST. M10x40 LG.	011						001	
001	W.A. OF WINDOW COVER	010	THIS DRG.	02				30.009	
001	W.A. OF WINDOW FRAME	009	THIS DRG.	01				5.976	
002	AL. ALLOY CHANNEL 6.35TKx101.6x50.8x20 LG	008						0.065	
001	SEE DETAIL	007	AL. ALLOY SHEET 9 TKx690x1782 LG					29.879	
002	S.C.O.	006	AL. ALLOY ANGLE 5TKx50x50x590 LG					0.743	
002	SEE DETAIL	005	AL. ALLOY ANGLE 5TKx50x50x1782 LG					2.245	
002	SEE DETAIL	004	AL. ALLOY SHEET 9 TKx600x1692 LG					9.27	
002		003	AL. ALLOY SHEET 9 TKx600x760 LG					11.081	
001	SEE DETAIL ROLL TO Ø1700	002	AL. ALLOY SHEET 9 TKx800x2684 LG					17.404	
001	ROLL TO Ø1700 BY 2684 LG.	001	AL. ALLOY SHEET 9 TKx800x2684 LG					52.177	

CUSTOMER: KARNATAKA POWER CORPORATION LIMITED				PROJECT: 1 X 700 MW BELLARY TPS UNIT#3			
BHARAT HEAVY ELECTRICALS LIMITED RUDRAPUR				DRN. NAME SIGN. DATE NO. OF VAR.			
DEPTT. E/D				APPD. R.K.BINDAL			
TITLE: ASSY. OF MAKE UP PIECES WITH 600x160° WINDOW				DRAWING NO. 31211400001			
SCALE: C/M/F				SHEET NO.- 01			
WEIGHT-KG				NO. OF SHEETS- 01			
REF. TO ASSY.DRG.				NO. OF ITEM			
IT.NO.				REV. 00			
SIZE- A3				CAD FILE NAME:			

ए.बी. जायसवाल S.B. Jaiswal
 अभि. (सामग्री प्रबंधन) Engg.(Mat.Mang.)
 बी.एच.ई.एल.-रुद्रपुर BHEL-Rudrapur
 उत्तराखण्ड-263153 Uttarakhand-263153

REV.	DATE	ALTERD	REV.	DATE	ALTERD	REV.	DATE	ALTERD	REV.	DATE	ALTERD
		CHEKED			CHEKED			CHEKED			CHEKED
			2			3			4		
									5		
									6		

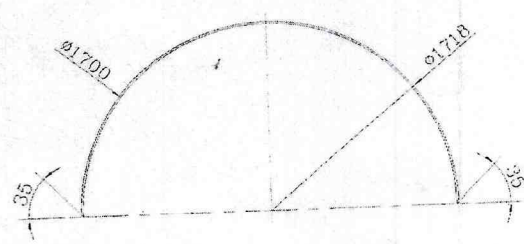
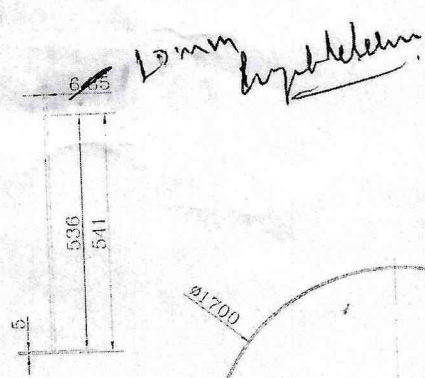
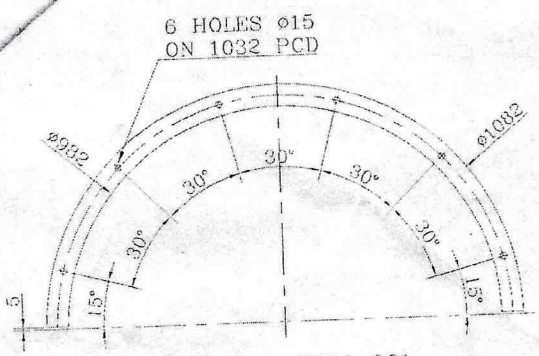

REV.	DATE	ALTERD	NOTE:-
		CHECKED	



FOR SAMPLE

REST OF THE COMPANY.
 ALSO LIMITED IT MUST NOT BE USED DIRECTLY OR INDIRECTLY IN ANY DETERMINED
 COPYRIGHT & CONFIDENTIAL: THE INFORMATION ON THIS DOCUMENT IS THE PROPERTY OF BHARAT HEAVY

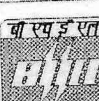
---	SEE DETAIL	003	9TK. x350 x2710 AL. ALLOY SHEET				29.019	
---	SEE DETAIL	002	10TK. x566 x1082 NEOPRENE RUBBER				2.565	
---	SEE DETAIL	001	10TK. x50 x1900LG. AL. PLAT					
VAR 00	REMARKS	ITEM NO.	DESCRIPTION	DRAWING NO.	IT.NO. VAR.	MATL.CODE MATL.SPON.	WT. QTY.	U C

		CUSTOMER		PROJECT/PRODUCT				
		N.T.P.C.		2X660 MW SOLAPUR TPS				
		BHARAT HEAVY ELECTRICALS LIMITED RUDRAPUR		DRN.	NAME	SGN.	DATE	NO. OF VAR.
DEPTT. D&E		UNTOL.DIM.CR. C/M/F		SCALE N.T.S.	WEIGHT-KG	REF.TO ASSY.DRG.	IT.NO.	NO.OF IT.
TITLE				DRAWING NO.			REV.	
AL. FLANGE, GASKET & MAKE-UP PIECE (FOR GEN. SIDE)				41241200010			00	
SHEET NO. - 01		NO.OF SHEETS - 01		SIZE - A4				

Signature

ए.बी. जायसवाल S.B. Jaiswal
 ए.बी. (सबसे प्रबंधन) Engg. (Mat. Mang.)
 बी.ई.एल.-रुद्रपुर BHEL, Rudrapur