



RD:DP:MPX:F-04  
Ref: 281504151

**BHARAT HEAVY ELECTRICALS LIMITED**  
CORPORATE RESEARCH & DEVELOPMENT DIVISION  
VIKASNAGAR, HYDERABAD - 500 093, INDIA

PHONES:23774494 (EXT:9804)  
FAX : 91 40 23770698

ENQUIRY

Date 08-03-2016

Enquiry for **Establishment of Regenerative Test Bed facility**

Enquiry No:281504151

Enquiry Date : 08-03-2016

Due Date: 09-04-2016

Indicative Delivery Date : 28-02-2017

Sl.No	Item Description	Unit	Qty
1	Establishment of Regenerative Test Bed facility as per enclosed Specifications	SET	1
2	Installation and Commissioning Charges	LOT	1

Please submit your quotation for the above material in sealed cover superscribed with enquiry no, enquiry date and due date subject to our enclosed terms and conditions. The quotations shall reach us on or before the due date by 12 noon. The tenders can also be dropped in the tender box kept at the security gate,BHEL R&D. In case you are not in position to submit the offer,please send reply suitably specifying the reasons.

Sl.No	Description	Document Ref.
01	Enquiry, General Terms & Conditions, Commercial Terms & Conditions etc.	Volume - 1
02	Technical specifications, Scope of Supply etc.	Volume - 2

Nishanth Polumahanthi  
Sr Engineer  
nishanth@bhelmd.co.in

	<b>ENQUIRY &amp; QUALIFYING CRITERIA</b>	Volume - 1 Enquiry No 281504151
Establishment of Regenerative Test Bed facility		

1	Tender inviting officer / Authority, Designation and Address	Additional General Manager(MM) BHEL R & D, Vikas Nagar (Near Balanagar), Hyderabad -500093
2	Item Description - Qty	1) Establishment of Regenerative Test Bed facility as per enclosed Specifications - 1 SET 2) Installation and Commissioning Charges - 1 LOT
3	Enquiry Reference no.	281504151
4	Indicative Delivery Date	28-02-2017
5	Due date, Time and place for submission of tender	09-04-2016 upto 12 noon. Sealed Quotations shall be addressed to AGM(MM), BHEL R & D Division, Vikas Nagar (Near Balanagar), Hyderabad AP,India Pin - 500 093 Quotations can also be deposited in the Tender box located at Security Gate of BHEL R & D BHEL shall not be responsible for any postal/courier delay.
6	Place, Date and time of Tech.Bid opening	Tender Opening Cell (Sangam) BHEL R & D Office. 09-04-2016, 2 PM
7	Mode of Submission of Tender	<p>Please submit your offer in one common sealed cover containing two parts in separate sealed covers as detailed below.</p> <p>1) First Cover shall contain:</p> <ol style="list-style-type: none"> <li>Signed General Terms &amp; Conditions (GTC)</li> <li>Filled and Signed Commercial Terms &amp; Conditions (CTC)</li> <li>Filled and Signed Vendor Specifications against BHEL Specifications (Item wise)</li> <li>Signed commercial bid</li> <li>Copy of Price-bid with price(s) cells blank (un-priced price bid)</li> </ol> <p>2) Second cover shall contain Price Bid Containing Price quotes, applicable taxes, installation and/or commissioning charges shall be spelt out clearly taking into account total charges rather than quoting vaguely such as charges per man-day or charges per engineer per day etc.</p> <p>If the price bid was found later to be different from the unpriced pricebid format in any way, the offer will be rejected summarily. The rates shall be quoted both in figures and in words.</p> <p>The offers can also be submitted through e-mail and have to be sent in PDF format (files with PDF extension only). Files having extensions other than PDF like RAR, EXE, JPEG etc. and with external links will not be considered. They have to be sent to e-mail id: 'eoffers@bhelrnd.co.in' only. Copies should not be marked to anyone. If the offers are marked to anyone other than to eoffers, their offer will not be considered.</p> <p>The e-mail offers should have two attachments.</p> <p>1) One attachment shall contain</p> <ol style="list-style-type: none"> <li>Signed General Terms &amp; Conditions (GTC)</li> <li>Filled and Signed Commercial Terms &amp; Conditions (CTC)</li> <li>Filled and Signed Vendor Specifications against BHEL Specifications (Item wise)</li> <li>Signed commercial bid</li> <li>Copy of Price-bid with price(s) cells blank (un-priced price bid)</li> </ol> <p>2) Second attachment shall contain Price Bid Containing Price quotes, applicable taxes, installation and/or commissioning charges shall be spelt out clearly taking into account total charges rather than quoting vaguely such as charges per man-day or charges per engineer per day etc.</p> <p>The subject of the e-mail should contain Enquiry No, Enquiry Date and Due date.</p>

	<b>GENERAL TERMS &amp; CONDITIONS (GTC)</b>	Volume - 1 Enquiry No 281504151
Establishment of Regenerative Test Bed facility		

SL.No.	Clause	BHEL REQUIREMENT
1	General	<p>a. All offers must include name of the contact person, phone no/mobile no, Fax no, email-id. Unsigned offers are liable for rejection.</p> <p>b. We, BHEL R&amp;D, is registered with Department of Scientific and Industrial Research (DSIR) for the purpose of availing Customs Duty exemption in terms of Government Notification no.24/2007-Customs dated 01-Mar-2007 &amp; Central Excise Duty Exemption in terms of Government Notification No. 16/2007-Central Excise dated 01-Mar-2007 as amended from time to time. Hence suppliers are requested to submit their bids clearly stating applicable taxes/duties. All foreign quotes will be evaluated with custom duty @ 5.15% for cost comparison.</p> <p>c. Taxes &amp; Duties quoted will be taken for evaluation of landed cost &amp; order placement and no change will be entertained later except in the case of changes made by the government. However please note that we are availing CENVAT credit for service tax and hence service tax will be excluded in calculation of landed cost to BHEL.</p> <p>In case any Taxes/ Duties exempted, a self declaration for the same may be attached to the offer. Changes in taxes and duties because of the changes in turn over etc will be to supplier's account.</p> <p>d. Where ever vendor registration form and EFT details have been submitted earlier, the same need not be submitted again unless there is a change.</p> <p>e. BHEL R&amp;D do not issue 'C' form .</p> <p>f. L1 status shall be decided on Cost to BHEL Basis.</p>
2	Late Tenders	Tenders received after due date/time(12:00hrs) will not be considered
3	Discrepancy in words and figures	<p>(a) If, in the price structure quoted for the required goods/ Services/ works, there is discrepancy between the unit price and the total price (which is obtained by multiplying the unit price by the quantity), the unit price shall prevail and the total price corrected accordingly, unless in the opinion of the purchaser there is an obvious misplacement of the decimal point in the unit price, in which case the total price as quoted shall govern and the unit price corrected accordingly.</p> <p>(b) If there is an error in a total corresponding to the addition or subtraction of subtotals, the subtotals shall prevail and the total shall be corrected; and</p> <p>(c). If there is a discrepancy between words and figures, the amount in words shall prevail, unless the amount expressed in words is related to an arithmetic error, in which case the amount in figures shall prevail subject of (a) and (b) above.</p> <p>(d) If there is such discrepancy in an offer, the same shall be conveyed to the bidder with target date upto which the bidder has to send his acceptance on the above lines and if the bidder does not agree to the decision of the purchaser, the bid is liable to be ignored.</p>
4	Two Part bid clarifications	In the case of Two-part bid, the vendor should furnish technical and commercial clarifications, if any, within stipulated time mentioned, failing which, it will be construed that the vendor is not interested in the tender and BHEL shall not consider the offer for further evaluation.
5	Price Impacts	In the event of any bidder, after finalizing the technical specifications and scope of supply, opting to revise their original bid, they have to submit the Price-Impact only. The Original price bid along with Price-Impact bid shall be opened during price bid opening. Unsolicited price impacts will not be considered.
6	Price bid evaluation	All offers in price bid opening or reverse auction shall be evaluated in Indian currency based on unit price, packing & forwarding, taxes/duties, freight charges if any, exchange rate, loading due to non-acceptance of our standard commercial terms. The exchange rate declared by State Bank of India under TT Selling rate on the technical bid open date shall be adopted for evaluating foreign currency bids.
7	Packing	The supplier shall be responsible for the goods being properly and adequately packed so as to prevent any, loss, damage or deterioration during transit.
8	Withdrawal	In case the supplier withdraws their offer before placement of order, BHEL reserves the right not to send next enquiry(ies). In case the supplier withdraws the quotation after its acceptance by BHEL or fails to supply the goods as per the terms and conditions of contract, or at any time repudiated the contract wholly or in part, BHEL shall be at liberty to cancel the Purchase Order and to recover from the supplier the extra cost and other loss, incidentals due to the breach of contract on the part of the supplier through risk purchase.
9	Risk Purchase	In case of default/late delivery, BHEL reserves the right to make alternate arrangement for procurement at suppliers risk and cost.
10	Banned List	The offers of the bidders who are in the banned list and the offers of the bidders who engage the services of the banned firms, shall be rejected. The list of banned firms is available on BHEL website <a href="http://www.bhel.com">www.bhel.com</a> . Guidelines for suspension of business dealings with suppliers/contractors are available on <a href="http://www.bhel.com">www.bhel.com</a> under supplier registration page
11	Over All L1	Order will be placed on overall L1 basis. Vendors should quote for all items, otherwise the offer will be rejected.
12	Additional Information	Suppliers are requested to visit our web site regularly for any updates and additional information, "All corrigenda, addenda, amendments, time extensions clarifications, etc. to the tender will be hosted on BHEL website only". The corrigendum will not be published in news paper.
13	Destination	Indian Vendors: Destination shall be Stores, BHEL R&D, Hyderabad. Foreign Vendors: 1) BHEL R.O.D Office, Mumbai, India for sea consignments and 2) BHEL R&D, Hyderabad, India for air consignments.
14	Arbitration	Subject to the jurisdiction of Hyderabad/ Secunderabad, Telangana, India in respect of any suit or other legal proceedings relating this contract.
15	Inspection	On receipt, the goods shall be subjected to inspection and our decision regarding the acceptability of the goods shall be final and binding on the suppliers.

16	Micro Small Enterprises (MSEs)	<p>MSE suppliers can avail the intended benefits only if they submit along with offer, attested copies of either EM II certificate having deemed validity (Two years from the date of issue of acknowledgement in EM-II) or valid NSIC certificate or EM II certificate along with CA certificate (Format as below) applicable for the year, certifying quantum of investment in plant and machinery within the permissible limit as per the act for relevant status (Micro or small) Where the deemed validity of EM II is over. Date to be reckoned for determining the deemed validity will be the last date of technical bid submission. Non submission of such documents will lead to consideration of their bids at par with other bidders and MSE status of such suppliers shall be shifted to Non MSE supplier till the supplier submits these documents. Certificate by chartered Accountant on letter head</p> <p>This is to certify that M/s .....(hereinafter referred to as 'company') having its registered office at ..... is registered under MSMED Act 2006, (Entrepreneur Memorandum No(Part-II) ..... dtd....., Category.....(Micro/Small). (Copy enclosed). Further verified from the Books of Accounts that the investment of the company as on date..... as per MSMED Act 2006 is as follows :</p> <p>1. For manufacturing Enterprises : Investment in plant and machinery (i.e. Original cost excluding land and building and the items specified by the ministry of small Scale Industries vide its notification No.S.O.1722(E) dated October 5, 2006.</p> <p>2. For Service Enterprises : Investment in equipment (Original cost excluding land and building and furniture, fittings and other items not directly related to the service rendered or as may be notified under the MSMED Act, 2006: Rs..... Lacs The above investment of Rs..... Lacs is within permissible limit of Rs..... Lacs for.....Micro/Small (Strike off which is not applicable) Category under MSMED Act 2006.</p> <p>Date:  (Signature) Name- Membership number -- Seal of Chartered Accountant</p>
17	Contract execution Bank Guarantee	<p>CEBG shall be required for all POs where value (Supply +E&amp;C) of each P.O. is estimated to be more than Rupees 20,00,000/- (INR). The successful vendor shall have to furnish a Contract Execution Bank Guarantee (CEBG) for 10% of the Total PO value in the prescribed format, enclosed, within 30 days from the date of P.O. LC, if any, shall be opened after receipt of CEBG. The CEBG shall be from one of the Consortium Banks of BHEL or from a reputed Bank and confirmed by any Consortium Bank of BHEL. All bank charges on account of issuance and conformation of CEBG whether incurred in India or outside India will have to be borne by the vendor. CEBG shall be kept valid unit 30 days after the date of E&amp;C Certificate, which will be issued on completion of Erection &amp; Commissioning of equipment which includes erection, commissioning, job proving, performance test, training to operators etc. as prescribed in PO. If the supplier fails to submit the CEBG even with in 60 days from the date of PO, BHEL reserves the right to cancel PO &amp; forfeit the EMD, if any, given by the supplier. In addition, in such case, action will be initiated in line with extant guidelines for Suspension of Business dealings with Suppliers.</p>
18	Foreign Vendors	<p>BHEL will deal directly with foreign vendors, where ever required, for procurement of goods. However, if the foreign principal desires to avail of services of an Indian agent, then foreign principal should ensure compliance to regulatory guidelines which require mandatory submission of agency agreement (as per *).  * The Agency Agreement shall specify 1) Agency commission, 2) Responsibilities of the agent, 3) Territory, 4) Agreement Period</p>
19	Signing & Stamping	<p>Documents of BHEL's all Terms and conditions submitted with the offer shall be signed and stamped in each page of authorized representative of the bidder</p>

**Documents submitted with the offer shall be signed and stamped in each page of authorized representative of the bidder**

**Read and agreed for all the above general terms and conditions**

**Signature of the bidder with Seal & Date**

	<b>COMMERCIAL TERMS &amp; CONDITIONS (CTC)</b>	Volume - 1 Enquiry No 281504151
Establishment of Regenerative Test Bed facility		

SL.No.	Clause	BHEL REQUIREMENT	SUPPLIERS ACCEPTANCE / REMARKS
1	Reverse Auction	<p>BHEL reserves the right to go for Reverse Auction (RA) instead of opening the sealed envelope price bid, submitted by the bidder. This will be decided after techno-commercial evaluation. All bidders to give their acceptance for participation in RA. Non-acceptance to participate in RA may result in non-consideration of their bids, in case BHEL decides to go for RA.</p> <p>In case BHEL decides to go for Reverse Auction, only those bidders who have given their acceptance to participate in RA will be allowed to participate in the Reverse Auction. Those bidders who have given their acceptance to participate in Reverse Auction will have to necessarily submit „online sealed bid” in the Reverse Auction. Non-submission of „online sealed bid” by the bidder will be considered as tampering of the tender process and will invite action by BHEL as per extant guidelines in vogue.</p>	
2	Two part	<p>Please submit your offer in one common sealed cover containing two parts in separate sealed covers as detailed below.</p> <p>1) First Cover shall contain:</p> <ol style="list-style-type: none"> <li>Signed General Terms &amp; Conditions (GTC)</li> <li>Filled and Signed Commercial Terms &amp; Conditions (CTC)</li> <li>Filled and Signed Vendor Specifications against BHEL Specifications (Item wise)</li> <li>Signed commercial bid</li> <li>Copy of Price-bid with price(s) cells blank (un-priced price bid)</li> </ol> <p>2) Second cover shall contain Price Bid Containing Price quotes, applicable taxes, installation and/or commissioning charges shall be spelt out clearly taking into account total charges rather than quoting vaguely such as charges per man-day or charges per engineer per day etc.</p> <p>If the price bid was found later to be different from the unpriced pricebid format in any way, the offer will be rejected summarily. The rates shall be quoted both in figures and in words.</p> <p>The offers can also be submitted through e-mail and have to be sent in PDF format (files with PDF extension only). Files having extensions other than PDF like RAR, EXE, JPEG etc. and with external links will not be considered. They have to be sent to e-mail id: 'eoffers@bhelrnd.co.in' only. Copies should not be marked to anyone. If the offers are marked to anyone other than to eoffers, their offer will not be considered.</p> <p>The e-mail offers should have two attachments.</p> <p>1) One attachment shall contain</p> <ol style="list-style-type: none"> <li>Signed General Terms &amp; Conditions (GTC)</li> <li>Filled and Signed Commercial Terms &amp; Conditions (CTC)</li> <li>Filled and Signed Vendor Specifications against BHEL Specifications (Item wise)</li> <li>Signed commercial bid</li> <li>Copy of Price-bid with price(s) cells blank (un-priced price bid)</li> </ol> <p>2) Second attachment shall contain Price Bid Containing Price quotes, applicable taxes, installation and/or commissioning charges shall be spelt out clearly taking into account total charges rather than quoting vaguely such as charges per man-day or charges per engineer per day etc.</p> <p>The subject of the e-mail should contain Enquiry No, Enquiry Date and Due date.</p>	
3	Validity of Offer	90 days from date of techno-commercial bid opening.	
4	Price basis	<p>The prices shall be firm for entire period of contract.</p> <p>The suppliers shall indicate packing and forwarding charges, if any, separately.</p> <p>All foreign suppliers shall quote the lowest prices on 'FOB-Nearest International Airport/Sea port' basis. An amount of 3% on basic value towards freight and insurance will be added for cost comparison.</p> <p>All Indian suppliers shall quote the lowest prices on 'free delivery at BHEL R&amp;D Stores or F.O.R destination' basis only.</p>	
5	Freight & Insurance	Insurance will be arranged by BHEL in case of FOB basis supplies. In such cases, an amount of 3% towards freight and insurance will be added for cost comparison.	
6	Agency Agreement	<p>Guidelines regarding dealing with Indian agents of foreign suppliers</p> <ol style="list-style-type: none"> <li>BHEL shall deal directly with foreign vendors, wherever required, for procurement of goods. However, if the foreign principal desires to avail services of an Indian agent, then the foreign principal should ensure compliance to regulatory guidelines which require mandatory submission of agency agreement.</li> <li>It shall be incumbent on the Indian agent and the foreign principal to adhere to the relevant guidelines of government of India, issued from time to time.</li> <li>The agency agreement should specify the precise relationship between the foreign oem and services to be rendered by agent / associate, whether general in nature or in relation to the particular contract, must clearly stated by the foreign supplier / Indian agent. Any payment, which the agent / associate receives in India or abroad from the oem, whether as commission or as a general retainer fee shall be brought out in record in the agreement and be made explicit in order to ensure compliance to the laws of the country.</li> <li>Any agency commission to be paid by BHEL to the Indian agent shall be Indian currency.</li> <li>When ever Indian agents are representing on behalf of their principals, the relevant authorization letter and agreement copy to be enclosed along with technical bid to consider the offer.</li> </ol>	
		<p><u>FOR INDIAN SUPPLIES :</u></p> <p>Suppliers are requested to quote within the delivery date mentioned in the enquiry. They shall also mention one of the following delivery periods compulsorily.</p> <p>1) Delivery Period from date of Purchase order =====</p> <p>2) Delivery Period from receipt of material / input data / drawings etc. from BHEL=====</p> <p>(if applicable)</p>	

7	Delivery Period	<p>3) <u>Delivery Period from receipt of approval of design documents / drawings etc. by BHEL</u> (if applicable)</p> <p>However BHEL shall inform the vendor about rejection of the offer before price bid opening in case of not meeting the delivery requirements of BHEL.</p> <p><u>FOR FOREIGN SUPPLIES :</u></p> <p>Suppliers are requested to quote within the delivery date mentioned in the enquiry. They shall also mention one of the following delivery periods compulsorily.</p> <p>1. Delivery Period from date of Purchase order :=====</p> <p>2. <u>Delivery Period from receipt of input data / drawings etc. from BHEL</u> (if applicable)</p> <p>3. <u>Delivery Period from receipt of approval of design documents / drawings etc. by BHEL</u> (if applicable )</p> <p>4. Delivery Period from date of LC Opening ===== (if applicable)</p> <p>5. Delivery Period from date of PO acceptance =====</p> <p>However BHEL shall inform the vendor about rejection of the offer before price bid opening in case of not meeting the delivery requirements of BHEL.</p> <p><u>Pl. mention any other issues/constraints like export clearance etc. explicitly, if any</u></p>	
8	Payment terms	<p>Payment</p> <p>1) Through L/C:Please note Payment through Letter of Credit (L/C) is for foreign currency payments only. Where the payments are through L/C (L/C opening charges shall be loaded for landed cost evaluation), payment of Supply value shall be 80% on dispatch and 20% on issue of E&amp;C Certificate. Payment of E&amp;C Value shall be made against E&amp;C certificate issued by BHEL. E&amp;C certificate shall be issued on satisfactory completion of erection, commissioning, job proving, performance test, training to operators etc, as envisaged in PO. The L/C shall be opened by BHEL as per following:</p> <p>(i) With in 30 days of receipt of acceptable CEBG, an irrevocable unconfirmed L/C will be opened for 30% of the payment towards supply, due on shipment i.e. 24% of the Supply value of PO (30% of 80%) Not earlier than 60 days before the shipment date, the value of this irrevocable unconfirmed L/C would be enhanced from 24% to 80% of the Supply value of PO</p> <p>The above L/C can be negotiated after the Shipment against submission of B/L or AWB and such other documents as mentioned in the in the PO. The above L/C will be valid for a period extending 21 days beyond the shipment date for negotiation of documents.</p> <p>(ii) 15 days prior to the scheduled &amp; confirmed arrival of the technicians of supplier with their names, an irrevocable unconfirmed L/C will be opened for a value equal to 20% of the Supply value of PO plus 100% of the E&amp;C value of PO. The validity of L/C would be sufficient to cover the period required for the completion of E&amp;C plus 21 days as negotiation period.</p> <p>This L/C can be negotiated after: (a) Completion of E&amp;C of the equipment in BHEL and against E&amp;C certificate issued by BHEL and (b) Submission of Performance Bank Guarantee (PBG) by Supplier in the prescribed Format valid for 30 days beyond the warranty period, from one of the Consortium Banks of BHEL or from a reputed Bank and confirmed by Consortium Bank of BHEL for 10% of total PO Value. The PBG confirmation charges shall be borne by vendor.</p> <p>Under all circumstances, CEBG shall be kept valid till be PBG becomes operational.</p> <p>2 Direct Payment ( foreign and Indian Suppliers):</p> <p>In case of direct payment , 80% payment of Supply value shall be made with in 45 days form the date of receipt of material at BHEL. Balance 20% of supply value plus 100% of the E&amp;C portion of PO Value will be paid against E&amp;C certificate issued by BHEL and submission of Performance Bank Guarantee (PBG) valid for 30 days beyond the warranty period by Supplier from any of the Consortium Banks of BHEL for 10% of total PO Value in the prescribed Format. The PBG confirmation charges shall be borne by vendor.</p> <p>3. Bank Guarantee and Loading against non acceptance of BHEL,s Payment Terms:</p> <p>If payment terms as mentioned by BHEL are not agreed by bidder, such bidder have to submit Bank Guarantee at the time of payment/opening of LC in the prescribed Format of the amount, exceeding 80% of the PO value, valid till issue of E&amp;C Certificate for the equipment. However, in no case, payment against dispatch shall exceed 90% of the PO Value.</p> <p>Additionally, for any deviation sought including as mentioned above, in Payment Terms by bidder w.r.t. tender conditions, following loading shall be followed:</p> <p>(A) Benchmark Prime Lending Rate(BPLR)of SBI as applicable on the date of tender opening +2%, for the amount &amp; period of relaxation sought by bidder.</p> <p>(B) On account of payment through LC if insisted by bidder , bank charges shall also be loaded for the deviation in (i) opening of LC by BHEL and (ii) period and amount of LC as per prevailing bank rates.</p>	
9	Time period for Supply and E&C	<p>1 Bidder should quote time period separately for 'Supply' and 'E&amp;C' of equipment.</p> <p>2 The bidders should quote their earliest schedule for supply and E&amp;C against the schedule indicated in the enquiry. BHEL, however, reserves the right to accept an offer not meeting the enquiry schedule.</p>	
		<p>1 For the purpose of penalty for delay in E&amp;C of the equipment the duration will be reckoned from the date of intimation by BHEL to vendor for readiness of site.</p> <p>2 Penalty on delay in 'Supply' and/or 'E&amp;C' will be applicable to the delays attributed to vendor . Penalty will be considered separately for 'Supply' and 'E&amp;C'.</p> <p>The rate of penalty for delayed Supply shall be @ 0.5% per week of delay of total PO value(Supply+E&amp;C). in supply subject to a maximum of 10% of total PO value (Supply+E&amp;C).</p> <p>The rate penalty for delayed E&amp;C shall be @0.5% per week of delay of total PO Value (Supply+E&amp;C) in E&amp;C subject to a maximum of 10% of total PO value (Supply+E&amp;C)</p>	

10	Penalty for Delay in supply and E&C	<p>Maximum penalty for delay in Supply and E&amp;C together shall be limited to 15% of total PO value (Supply+E&amp;C).</p> <p>In case PO includes more than one machine, the penalty shall be limited to 0.5% per week of delay on total PO Value(Supply+E&amp;C) for the delayed machine.</p> <p>3 Loading on account of non-acceptance of Penalty for delayed Supply and /or E&amp;C shall be as under: In case any bidder is not accepting the above penalty for delayed Supply and/or E&amp;C, the offer of bidder shall be loaded to the extent to which it is not agreed by the bidder.</p> <p>4 In case, any shortage is noticed viz-a-viz PO requirement in the main equipment/spares, such shortages shall be replenished by supplier on for destination basis without any cost implication to BHEL i.e. Custom Duty and freight charges etc. up to destination for such short supplies shall be borne by the supplier.</p> <p>5. Supply period indicated by bidder should include reasonable time required for approval of drawings and other inputs from BHEL. In the Techno-Commercial Bid, the bidder shall submit milestones for various activities in co-relation with Supply and E&amp;C period quoted by him.</p>	
11	Weight and Packing Dimensions.	The Supplier shall indicate the shipping weight (Kgs) and dimensions(L x W x H in cms) clearly along with offer.	
12	Nature of Vendor submitting the Offer	OEM / Agent / Representative / Dealer / Distributor / Stockist / Trader / Reseller / Channel Partner/ System Integrator / Any Other (Pl. Specify)	
13	Foreign Suppliers without Indian Agent	To be quoted in Foreign Currency. Purchase Order will be placed on Foreign Supplier.	
14	Foreign Principal availing services of an Indian Agent	<p>Foreign principal should ensure compliance to regulatory guidelines which require mandatory submission of Agency agreement. (as per *) To be quoted in Foreign Currency.</p> <p>Purchase order will be placed on Foreign Supplier. Agency Commission will be paid to Indian Agent in Indian rupees.</p> <p>* The Agency Agreement shall specify 1) Agency commission, 2) Responsibilities of the Agent, 3) Territory, 4) Agreement Period</p>	
15	Indian Agent desirous of quoting imported Equipment	<p>Any Indian Agent desirous of quoting imported Equipment, they should submit the quote in foreign currency along with copy of agency agreement (as per *). To be quoted in Foreign Currency.</p> <p>Purchase order will be placed on Foreign Supplier. Agency Commission will be paid to Indian Agent in Indian rupees.</p> <p>* The Agency Agreement shall specify 1) Agency commission, 2) Responsibilities of the agent, 3) Territory, 4) Agreement Period</p>	
16	Indian Vendor Offering fully imported Equipment	<p>To be quoted in Foreign Currency. Purchase order will be placed on Foreign Supplier.</p> <p>As BHEL R&amp;D is registered with Department of Scientific and Industrial Research (DSIR) for the purpose of availing Customs Duty exemption, BHEL desires to import the equipment from foreign supplier with concessional custom duty.</p> <p>In case if it is not possible to quote in foreign currency for imported items, reasons for the same to be mentioned</p>	
17	Indian Vendor Offering Equipment with partly imported & partly indigenous Items/Services	<p>Imported Items to be quoted in Foreign Currency.(**) Purchase order for imported items will be placed on Foreign Supplier.</p> <p>Indigenous items/services to be quoted in Indian rupees.(**) Purchase order for indigenous items/services will be placed on Indian Supplier.</p> <p>** 1) As BHEL R&amp;D is registered with Department of Scientific and Industrial Research (DSIR) for the purpose of availing Customs Duty exemption, BHEL desires to import the foreign items from foreign supplier with concessional custom duty. 2) In case if it is not possible to quote in foreign currency for imported items, reasons for the same to be mentioned. 3) Authorisation Letter from Foreign Supplier should be submitted.</p>	
18	Indian Vendor offering Items manufactured / assembled / customized in India with imported/indigenous material/sub components.	Please specify both imported and indigenous content in percentage / customization done.	

**Note :** All the clauses of the above format should be filled and submitted with the Techno Commercial Bid (Part-1). The filled in BHEL Commercial terms & Conditions format submitted with technical bid, responding to all the clauses duly signed with seal **only shall be considered**. Any other Commercial terms & conditions of bidders entered else where in their offer shall not be considered and are liable for rejection.

**Read and understood the above commercial terms and conditions**

**Signature of the bidder with Seal & Date**

	<b>OTHER TERMS &amp; CONDITIONS</b>	Volume - 1 Enquiry No 281504151
Establishment of Regenerative Test Bed facility		

SL.No.	Clause	BHEL REQUIREMENT	SUPPLIERS ACCEPTANCE / REMARKS
1	Implementation of Integrity Pact (IP):	To oversee implementation of Integrity Pact (IP), Shri D.R.S Chaudhary, IAS (Retd.), has been nominated by BHEL as Independent External Monitor (IEM). The Contact details are Flat No. L-202 & L-203 (1st Floor); Ansal Lake View Enclave; Shamlia Hills; Bhopal- 462 013 (M.P.) Ph: +91 755 4050495; e-mail: dilip.chaudhary@icloud.com The prospective bidders have to sign and stamp the attached Integrity Pact document and to be submitted along with the technical bid, failing which the offer shall be rejected.	

**Signature of the bidder with Seal & Date**

		ITEM SPECIFICATIONS		Volume - 2 Enquiry NO 281504151
Establishment of Regenerative Test Bed facility				
SL.No.	Item			
1	<b>Establishment of Regenerative Test Bed facility as per enclosed Specifications</b>			
	sl no	Descriptions	BHEL Specifications	Vendor Specifications/ Deviations
	1	Establishment of Regenerative Test Bed facility	As per Enclosed Technical Specifications	
		Minimum Acceptable Warranty	Supplier shall comply to the minimum acceptable warranty period. The offers of the suppliers not complying to the minimum warranty period will be rejected. The minimum acceptable warranty period is 12 months.	
2	<b>Installation and Commissioning Charges</b>			
	sl no	Descriptions	BHEL Specifications	Vendor Specifications/ Deviations
	1	Installation and Commissioning Charges	Installation & Commissioning charges will include services to be rendered at BHEL like erection, commissioning, job proving, performance tests, and on-site training to operators etc. The estimated percentage value of these charges as per BHEL: 5% of Unit price. The Supplier should quote these charges as % of Unit price separately in technical bid. Only in case where quoted value is less than the value (in %) specified above or separate value is not mentioned in the offer, value for Installation and commissioning shall be deemed to be considered as the value indicated above & accordingly supply value will be adjusted from that quoted value and balance will be released as E&C payment as per Payment terms- under Commercial terms and conditions of enquiry.	
G	<b>General Specifications</b>			
	sl no	Descriptions	BHEL Specifications	Vendor Specifications/ Deviations
	1	Pre-Qualification criteria for establishment of TEST BED	<p>1. The bidder shall have proven expertise in the supply and commissioning of inverter drives and its associated equipment for test bed applications. To this Bidder shall submit the PO details, Customer details and Technical details of the Test Bed systems supplied in last 5 years, out of which Technical evaluation and selection will be done by a Technical Committee at BHEL and the decision of BHEL regarding this will be binding.</p> <p>2. The bidder shall furnish specific details of the company performance in the enclosed Annexure-I (A. Capacity details; B. Performance of supplies to BHEL).</p> <p>3. BHEL reserves the right to contact the referred parties to carry out independent Verification/confirmation of the satisfactory performance of the equipment. PROSPECTIVE BIDDERS SHALL GIVE THOSE REFERENCE ONLY WHO ARE WILLING TO EXTEND INDEPENDENT CONFIRMATION WHEN APPROACHED BY BHEL CONFIRMATIONS AND NOT ABSTAIN FROM THE SAME ON THE GROUNDS OF CONFIDENTIALITY.</p>	
			After completion of standard warranty period, OEM / authorised Indian Agent should be able to provide Annual Maintenance for period of two years beyond standard warranty period. The Vendor should quote Annual Maintenance Contract (AMC) Charges separately on per year basis in terms of % of equipment cost / lumpsum as detailed	

		<p>below</p> <p>1. % of equipment cost/ lumpsum for 1st year 2. % of equipment cost/lumpsum for 2nd year</p> <p>In case, if the original quote for supplies and AMC Charges is not in INR, and Indian Office/ Indian agent executes the AMC Order, then AMC Order shall be placed in INR with exchange rate on technical bid open date. BHEL reserves the right to release separate AMC order after completion of standard warranty period as per the AMC charges quoted in this bid. The quoted AMC charges will be considered for evaluation of the bid.</p>	
	AMC Payment Terms	Payment after completion of each Quarter, pro-rata. One preventive visit per quarter. No limit of Breakdown visits. No preventive visit, No payment.	
	Delivery Period	Desirable Delivery Period Supply of the Equipment - 36 weeks from Purchase Order Date Installation and Commissioning - 8 weeks from site readiness. Vendor to specify clearly.	

\* Vendors are advised to write specifications in detail and not to write like 'Complied/ Yes / No ' etc. in specifications.

**Signature of the bidder with Seal & Date**

Enq281504151 dated 08-Mar-2016

**TECHNICAL SPECIFICATIONS**

**FOR**

**ESTABLISHMENT OF REGENERATIVE TEST BED FACILITY**

**AT**

**BHEL Corporate R&D Vikasnagar, Hyderabad**

**INDEX**

SECTION - I	PRE-QUALIFICATION CRITERIA
SECTION - II	GENERAL SPECIFICATIONS/REFERENCES
SECTION - III	APPLICABLE STANDARDS
SECTION - IV	SCOPE OF SUPPLY & TECHNICAL SPECIFICATIONS
SECTION - V	INSPECTION AND TESTING PROCEDURE

## **Section I**

### **Pre-Qualification Criteria for the Establishment of Test Bed**

1. The bidder shall have proven expertise in the supply and commissioning of inverter drives and its associated equipment for test bed applications. To this Bidder shall submit the PO details, Customer details and Technical details of the Test Bed systems supplied in last 5 years, out of which Technical evaluation and selection will be done by a Technical Committee at BHEL and the decision of BHEL regarding this will be binding.
2. The bidder shall furnish specific details of the company performance by submitting a duly filled format at Annexure 1
3. BHEL reserves the right to contact the referred parties to carry out independent Verification/ confirmation of the satisfactory performance of the equipment.

PROSPECTIVE BIDDERS SHALL GIVE THOSE REFERENCE ONLY WHO ARE WILLING TO EXTEND INDEPENDENT CONFIRMATION WHEN APPROACHED BY BHEL CONFIRMATIONS AND NOT ABSTAIN FROM THE SAME ON THE GROUNDS OF CONFIDENTIALITY.

## SECTION - II

### GENERAL SPECIFICATIONS

<b>1.1 SITE CONDITIONS :</b>	<b>UNIT</b>	<b>RANGE</b>
Temperature of ambient air	C	5 to 50
Relative humidity	%	10 to 75
Plant Elevation above MSL (Assumed)	m	550
Seismic Zone		2

#### **1.2 POWER SUPPLY SYSTEM**

System voltage /DG Supply	: 415, $\pm 10\%$ System
Frequency	: 50HZ $\pm 6\%$
Phase	: 3 ph, 4 wire.
System Grounding	: Solidly Grounded System.
DG SET Neutral Grounding	: Solidly grounded

## SECTION – III

### APPLICABLE STANDARDS

- 1) The equipment & accessories covered by this Specification shall be designed, manufactured and tested in accordance with the latest relevant Indian standards and codes of practice.
- 2) The Test Bed & accessories shall also conform to the latest Electricity Rules AS APPLICABLE & other related statutory agencies as regards safety, Earthing and other essential provisions specified therein for installation and operation at BHEL Corporate R&D Vikasnagar Hyderabad.

#### Applicable Standards: -

IS-5, 1994	Color for ready mixed paints & enamels
IS-694, 1990	PVC Insulated cables for working voltage up to and including 1100 Volts.
IS-1248Part - 1 to 9, 1991	Direct acting indicating analogue electrical measuring instrument & their accessories.
IS-2026, Part-1, 1991	Power Transformers (General)
IS-2551, 1990	Danger Notice Plates.
IS-2705,Part-1, 2,3,4, 1992	Current Transformers
IS-3156,Part-1, 2,3,4, 1992	Voltage Transformers
IS-3231,Part-0, 1,2,3, 1992	Electrical Relays for Power System Protection.
IS-5082, 1991	Wrought Aluminum & Aluminum alloy bars, Rods, Tools & Sections for Electrical purpose.
IS-5578, 1991	Guide for marking of Insulated Conductors.
IS-8623, Part-1, 1993	Low voltage Switchgear & Control Gear assemblies.
IS-8923, 1990	Warning Symbol for dangerous voltages.
IS-13703-2-1, 1993	Low Voltage Fuses: Supplementary requirement for fuses for Industrial applications.
IS-12065, 1987	Classification of degree of protection provided by enclosures of electrical equipment.

This above list is not exhaustive. Standards not listed above but are applicable also to be followed to meet requirement.

## Section-IV

### SCOPE OF SUPPLY & TECHNICAL SPECIFICATION

**Description** : Establishment of One Number Test Bed for Testing Permanent Magnet Technology based Synchronous Machines (Reversible) Up to 1 MW as per details given below

#### **1. Application:**

To conduct functional and endurance testing on Reversible PM Technology based machines with desired load characteristic and operation. The supplied system shall be designed to test machines (Machine Under Test) of rating in the range of **200 kW to 800 kW (MUT)**, with one machine at a time. System shall be designed for 125% loading of MUT.

#### **2. Operation:**

MUT shall be coupled to the dynamo or loading machine with in-line Torque Transducer as shown in Fig. 1. The loading Dynamo along with suitable drive shall load the MUT as per the set load torque and speed.

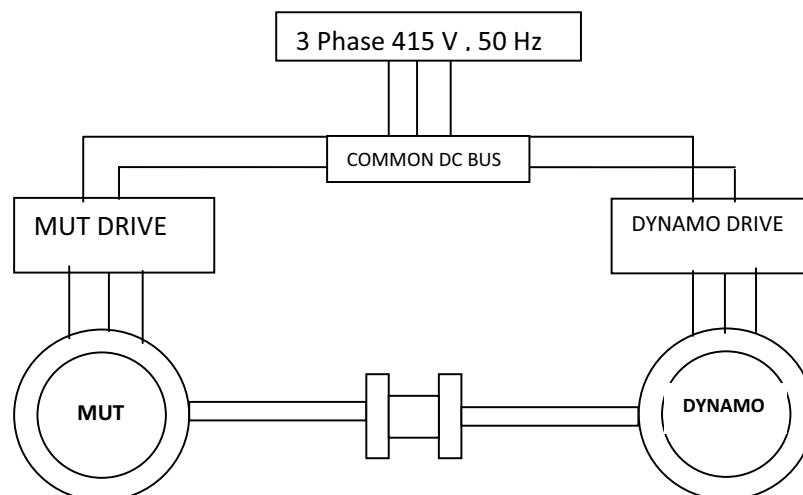

**Fig. 1.0** General scheme of Test bed

Typical required load torque characteristic of the MUT is given in Fig. 2.0.

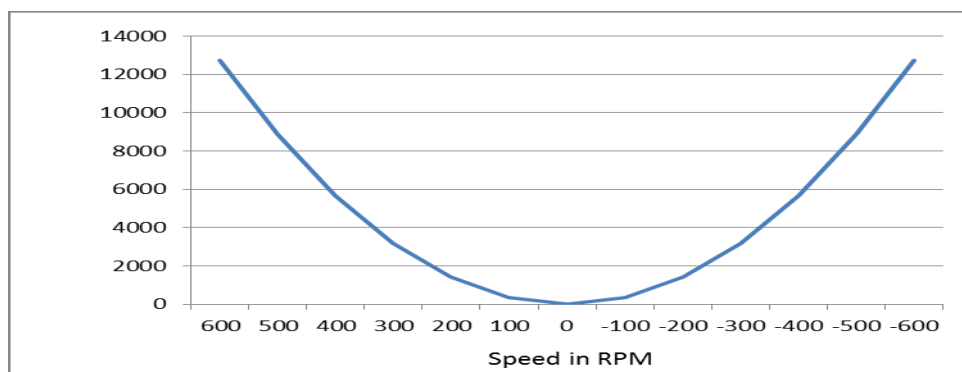

**Fig.2.0** MUT Torque-Speed characteristics

It is required to provide a complete test bed solution including Dynamo, drive, Switchgear, couplings, controls and instrumentation as per system configuration.

### **2.1 Main Tests to be performed on MUT:**

- No load OCC tests from zero to rated speed  
Time (duration) and Number of steps to reach the rated speed/voltage during OCC test shall be programmable.
  - User programmable load test (Predefined duration as well as configurable duration) for Constant Torque as well as Constant Speed Modes.
  - Variable load/torque test with programmable torque and speed parameters with variable duration.
  - Short Circuit test ( Auto/Manual)
  - Over speed (10 % over speed) test for a short duration (15 minutes.)
  - Temperature raise test at different load voltages/currents.
  - Efficiency Tests at variable loads and speeds.
  - Load throw test.
  - Overload test with defined frequency.
  - Speed Reversal test.
  - **Other relevant tests as per latest IEC 60034-1 standard**
- 2.2 Major Parameters to be monitored are:**

- AC GRID Voltage
- AC GRID Current
- AC GRID frequency
- AC GRID power factor
- AC GRID Power ( All components)
- AFE Input Voltage
- AFE Output Voltage
- AFE Input Current
- AFE Output Current
- AFE grid side Power factor
- MUT Input Voltage
- MUT Input Frequency
- MUT Input Current
- MUT Input Power
- MUT Input Power factor
- DC-DC Converter Input Voltage
- DC-DC Converter Input Current
- DC-DC Converter Input Power

- DC-DC Converter Output Voltage
- DC-DC Converter Output Current
- DC-DC Converter Output Power
- Controller Under Test (CUT )/ MUT Drive Input Voltage
- MUT Drive /CUT Input Current
- MUT Drive /CUT Input Power ( All components)
- MUT Drive /CUT output THD
- MUT temperature
- MUT actual speed
- MUT efficiency
- MUT shaft Torque using Torque transducer
- Driving Machine output voltage
- Driving Machine output current
- Driving Machine output frequency
- Driving Machine output Power
- Driving Machine efficiency (Computed)
- Actual electrical Loading on the MUT ( Computed)
- Driving Machine temperature
- Bearing temperature
- Total loading system efficiency ( Computed)
- Vibration level of MUT
- Vibration level of Driving machine
- Noise of MUT

### 3. Scope of work:

Design, Engineering, supply and commissioning of complete Test Bed system and auxiliaries with required Dynamo, drive, controls , instrumentation, data acquisition system and PC based programming station with user friendly windows based HMI. Test bed documentation including all sub-systems as per applicable standards. Broad System Topology is shown in Fig. 3.0.

**3.1 Scope of Supply:** One Set of Test bed comprising the following major sub-systems (Items) as per Table –I.

Sl. No.	BHEL Specs	Qty	Unit
<b>1</b>	<b>Input Supply</b>		
a	750KVA, Convertor duty, 415V/415V, 3Phase Step up, Step down and Isolation Power transformer with a $\pm$ 25% range from rated voltage.	1	No
b	Auto changeover panel from Utility to 500 KVA DG set and vice versa with safety interlocks and AVR-DG set to be provided by BHEL.	1	No
<b>2</b>	<b>Inverters Section</b>		
a	Bi-Directional Converter/Inverter as required for Dynamo, Capacity -1000 KW or more Air/Liquid Cooled AC Drive with suitable cooling mechanism.	1	No
b	Bi-directional Buck Converter – Common DC bus to output 170 to 350 V DC of 1000 kW or more.	1	No
c	Active front end unit - Capacity -500 KW or more Air/Liquid Cooled, AFE System with suitable cooling mechanism.	1	No
<b>3</b>	<b>Motors (Dynamo)</b> -1000 KW at 600 RPM or more, 415V, Water cooled Motor with suitable vibration mount pads with necessary bolts.	1	No
<b>4</b>	<b>Sensors/instrumentation</b> :-As required for monitoring parameters listed in sec. 2.1. With redundancy for critical sensors required for the closed operation.	1	No
<b>5</b>	<b>Switch Gear</b> :-Required Switchgear as per SLD in Fig. 3.0.	1	Set
<b>6</b>	<b>Power Cables</b> :-As required for the complete implementation of Test Bed.	1	Lot
<b>7</b>	<b>Control/Automation Cables</b> :-As required for the complete implementation of Test Bed.	1	Lot
<b>8</b>	<b>Cable Trays for All cables</b>	1	Lot
<b>9</b>	<b>Control Panel/Operator Interface Panel</b>	1	Set
<b>10</b>	<b>Data Acquisition System</b> :-Reputed and configurable with Minimum 48 Nos- DI ; 32 Nos – AI; 48 Nos- DO; 8 Nos-AO; 32 Nos. RTDs.	1	No.
<b>11</b>	<b>Battery Bank</b> :-Lithium Ion battery bank min. 600V/200 Ah	1	Set

	along with necessary peripherals, charger and safety interlocks suitable for Auto changeover max.-5mins		
12	<b>Desktop PC based Remote Operator Interface work station</b>	1	No.
13	<b>Local Operator interface panel near the machine bay</b>	1	No.
14	<b>Auxiliary Large Display Unit of size: 42" or more with communication interface to main HMI</b>	1	Nos.
15	<b>UPS with a 30 minutes battery backup of required Capacity for all the Drive controllers and Data Acquisition System.</b>	1	Lot
16	<b>Portable Laptop based Remote Operator Interface work station-</b> Intel Processor (Quad Core 2.80 GHz, 3.80GHz or better), 500GB 2.5inch serial ATA (7200 RPM) Hard Drive, ≥ 15.6" Display with necessary licensed software	2	Nos.
17	<b>Windows based Customized HMI</b>	1	Lot
18	<b>Licensed Supporting software (OS &amp; Others)</b>	1	Lot
19	<b>Color Laser Printer</b>	1	No.
20	<b>Other Supporting miscellaneous items as required to complete the above scope of supply</b>	1	Lot
21	<b>Complete Documentation ( System level and sub-systems)</b>	1	No.
22	<b>Earthing materials:-</b> Such as earthing electrodes with its accessories and hardware for earthing pits , earthing strips and copper wire for equipment body & neutral earthing. This includes earthing strip along the cable tray and safety items such as rubber mat, fire extinguishers, danger boards, buckets, first aid chart etc as required.	1	Lot
23	Earth Pits for electronic and instrumentation, supply & commissioning of Prefabricated CPRI approved Earthing rod (Pipe In Pipe Technology with conductive mixture) 80mm Diameter & length 3 M.	1	Lot
24	<b>Cooling Tower along with DM/RO water plant of suitable capacity</b>	1	Lot
25	<b>MAJOR MECHANICAL ITEMS</b>		
a	Fabricated base frame	2	Nos
b	Insulated pads ( Min)	14	Nos
c	Motor Base	2	Nos
d	Reaction Bracket	1	Set
e	Torque Sensor Base	1	Set
f	Shaft Couplings	1	Set
g	T – slot Plate 6000mmx4000mmx300 mm available at BHEL R&D can be used.		
h	Universal Joint Shaft	1	Set
i	Bearing Block	1	Set
j	Bearing block base	1	Set

k	Clamping Block	5	Nos
l	Chiller Line/Air Ducting as required.	1	Lot
<b>26</b>	<b>Erection &amp; Commissioning</b>		
a	Analysis + 3D Modeling	1	Lot
b	Broad Foundation Design	1	Lot
c	Material handling (within site)	1	Lot
d	Complete System Simulation using reputed simulation tools	1	Lot
e	Software Development	1	Lot
f	Cooling tower work	1	Lot
g	Chiller Line/Air Ducting work as required.	1	Lot
h	Any other work required for E&C	1	Lot
<b>27</b>	<b>Warranty –One year</b>		

### MAIN FEATURES:

- **Inverter/ Converter Topology:** The loading setup system shall be designed with latest technology based IGBT converters/inverters having Air/liquid/refrigerant cooled drive systems. Total system shall draw minimum possible input power less than 200 kw at 0.95 pf or better from the main in-coming supply along with necessary safety interlocks. For closed loop speed and torque control operation speed shall be measured using speed sensor (actual) and torque shall be measured by a torque sensor (actual). 1 MW VFD plus machine is to be started through AFE and Transformer/ DG set and 1 MW Dynamo shall take over afterwards.
- **Instrumentation:** Instrumentation as required for signals, data measurement and processing from all machines/drives/controls are included in the scope. Control cables of suitable length shall be supplied along with instrumentation. Instrumentation shall support all control and operational requirements for analog, digital I/O's as mentioned. Required accuracies of less than 1% of the actual value are to be provided to meet the overall system requirements. Standard communication protocols are to be used where ever required. Vibration and noise of MUT shall be measured and logged. Control cables and others shall be supplied with suitable shielding and other protections. Especially all power cables for Inverters/AFE are to be a specific EMI/EMC complaint VFD cables. All signal cables and glands are to be shielded for EMI/EMC compliance and complete cabling to be executed with structured routing and industrial cabling method.
- **Control and Monitoring with Local Control Unit and Remote Control Unit:** Total control, operation and access to the system shall be provided at two nodes (1.Local which is near the machine, 2.Remote which is in the control room) and only one node being active at any point of time. Two modes of operation Auto and Manual are to be provided for both local as well as remote

nodes. Provision for switching from one node to another shall be provided at each node and through HMI. Provision to be made to operate either at local node through hardwired switches or through HMI. If one node is enabled for control operation other shall become disabled and only data monitoring enabled at that node. Operator shall be able to monitor real time parameter values and system component status at both nodes. Provision for feeding numeric control parameters shall be allowed within limits.

- **Control Room:** PC based Remote Control is located in a proposed control room at a distance of about (min) 25 meters from the test bed through a panel.
- **PC based HMI:** Windows based user friendly with customized GUI to be provided. Data (parameter values and system component status) viewing, logging and saving with respect to real time is required. Provision for offline data entering and saving is required in addition to the online data logging. Offline data is manually entered for a few chosen parameters. Data log interval shall be selectable and variable based on type of machine and test conducted. User configurable reports based on the current data or based on the historical data are to be provided.
- **Auto Operation:** In AUTO operation required load/torque curve parameter will be set by the user with required security authentication. Rise or lowering the parameters shall be ramp in nature and ramp rate will be decided during detailed engineering as per the scheme. Control flow during auto operation shall be smooth with all protections enabled.
- **Manual Operation:** In manual operation mode full control is commanded by operator at each and every stage of system by soft and hard switches. Envisaged tests are to be carried in both modes (AUTO/MANUAL) of operation. Changeover from one mode to other shall be done by closing controls in current operating mode sequentially. Required software and hardware interlocks shall be in operation under all modes of control.
- **Local Control Unit (LCU):** Located very near to the test bed with full control access. LCU to be supplied with an interactive and user-friendly 19" or more LCD touch colour display, which is operated locally. The operator interface shall be used for loading system programming, parameter monitoring and troubleshooting the system. Control panel with in-built control system and logics shall satisfy all system functional conditions. It shall display all real time operating variables and all loading system programming parameters as desired. The operator interface shall be capable of displaying a specific user selected essential

parameter on power-up. This power-up parameter would typically be a parameter those are important to the operator such as Loading system speed or Loading.

- **Remote Control Unit (RCU) for monitoring, controlling and data logging:** Automation shall be done with Real Time controller with the help of Industrial grade computer, with 19" (min) color monitor with customized software to control the system remotely and to log the system parameters. Windows based GUI to operate the test rig in Auto mode with provision to line up the sequences of the tests and in Manual mode shall be provided. HMI to be provided on a portable Industrial Laptop for operating the HMI at different locations. Large Factory display of 42" or more to be provided to display the HMI pages as appeared on the Remote control unit.
- **Indications:** Indications to be provided on drive control panels and others with lamps, which shall be clearly visible from a distance of minimum of 5 meters. Typical indications are for Input power ON/OFF, System Healthy/Faulty/Ready, MUT DRIVE Power ON/OFF, MUT Drive ON/OFF, MUT Rotation, Regeneration Drive ON/OFF, and Regeneration ON/OFF, Regeneration Healthy/Ready / faulty and Emergency stop.
- **Control Features:** Control mode selection for constant torque or constant speed is to be provided. DSP based controller with suitable logics for smooth operation and control are to be provided with all IGBT based systems. Speed Control to be ensured within 0.5% speed regulation.
- **Base frame:** All the mechanical components shall be mounted on a base frame which is suitably engineered for Static, Dynamic and Transient conditions with sufficient space for MUT mounting as per Fig. 1.0. Vendor shall clearly specify floor strength required for satisfactory system operation under all conditions, during detailed engineering stage
- **Equipment and personnel safety:** All rotating parts shall have safety guards as per standard engineering practices along with necessary electrical, mechanical protection and interlocks.
- **Control panels:** Protection class of IP42 with Switch Fuse Unit (SFU) and other necessary protections for electrical & electronics components for systems best performance are to be provided. All the power electronic converters shall be kept in cubicles and as compact as possible. Air Cooling (Natural or Forced Air Cooled with suitable blowers) is to be ensured, with suitable safety guards where ever required. Cable Entry for the Input and output cables shall be from bottom of the panel.

- **Control Flow Charts:** Supplier shall submit control flowcharts, logic, algorithms and control loop logics for approval during detailed engineering.
- **Base Frame:** Entire skid structure will be mounted on 'T' slotted Cast Iron bedplates with nuts & bolts
- **Industrial Safety:** As per latest IEC 60034-5 standard for rotating & electrical parts.

➤ **GENERAL:** Available Grid/Mains/DG Supply:

- a. No of Phases : 3-Phase
- b. Voltage : 415V +/- 10%
- c. Frequency : 50Hz +/- 6%

➤ **Auxiliary Supplies:** Any auxiliary power supplies required for system operation shall be derived from input feeder and Required component/items are included in supplier scope

➤ **Machine Under Test along with Drive:-** It will be provided by BHEL

➤ **Operating conditions:**

- a. Application: Indoor
- b. Relative Humidity: 75% (0-50 Deg C. Temperature)
- c. Operating Temperature: up to 50 Deg C.

➤ **Warranty:** Supplier shall provide warranty for a period of 1 year from the date of E&C of system.

In addition, kindly provide the following information:-

➤ **Information required along with offer:**

- a. Loading system design methodology and complete bill of material of all components and parts.
- b. Control Scheme of loading system.
- c. Dimensional drawing of all major components.
- d. Weight of individual modules.

e. Catalogues of the components/sub-systems offered.

f. Completely filled and duly signed Technical compliance sheet.

➤ **Offer shall include the following:**

a. System Design, engineering, automation, testing and supply of (200-800) kW range PM Synchronous Machine Regenerative loading system meeting required specifications.

b. Erection and commissioning.

c. One year warranty.

d. Training.

e. Milestones of the project.

f. Break up cost against each activity mile stone

## Section-IV

### ➤ **INSPECTION AND TESTING PROCEDURE**

- a. Pre Dispatch Inspection (PDI):** BHEL representative(s) will be present at manufacturer's works for witnessing of PDI testing as per specifications. During PDI, BHEL will not supply any MUT/Equivalent machine. Supplier shall make their own suitable arrangements. The loading test setup system shall be loaded by at least 25% of rated power for demo test functionality at supplier's premises. Demonstrating to be carried out with all the sequence of test protocols as mentioned above. Testing of individual sub-systems is also to be offered during the PDI.

Vendor shall submit the complete Test procedure and Quality Plan for the project along with the detailed procedures for all the checks and performance tests to be carried out at works as well as after installation for necessary approval by BHEL.

The equipment shall be dispatched only after testing/inspection at supplier's works and on written clearance from BHEL. Vendor to give sufficient Notice to BHEL for carrying out PDI.

- b. Erection & Commissioning (E&C):** Erection & commissioning of the complete Loading System is at BHEL R&D, Hyderabad and it is under supplier's scope. Final Acceptance will be based on successful completion of the Loading system at FULL LOAD test demonstration using a test set-up with above specifications during E&C. All the required equipment and material for installation and commissioning are included in supplier's scope. Material handling & shifting are under supplier's scope.

The vendor to clearly specify the time required for E&C.

- c. Training:** Training is required for two persons from BHEL for a minimum period of 5 days at the place of E&C.

#### ➤ **Documentation:**

- a. Schemes, Flow charts, Quality plans, wiring diagrams and drawings (within 30 days from order placement)
- b. Simulation Results
- c. System Analysis results
- d. Complete Bill of Material (item-wise) for the equipment supplied

e. O&M manuals for the complete system as well as for all major sub-systems

f. Erection, Commissioning report – 2 copies and Maintenance manuals – 3 copies

g. Test and guarantee certificates of individual components/subsystems.

h. All soft copies of documentation, algorithms, control logics, wiring diagrams.

**Note:**

- Civil works only for the E&C of the test bed is to be carried out by the supplier.
  - Any special tools required for commissioning and troubleshooting shall be brought by supplier.
  - Point-wise confirmation to this to be given along with the technical offer. Deviations if any shall be indicated separately. If there are no deviations to the specifications, supplier shall mention the same explicitly. A reply from vendor stating that “Equipment will generally meet the specifications” will not be accepted by BHEL Corp R&D.

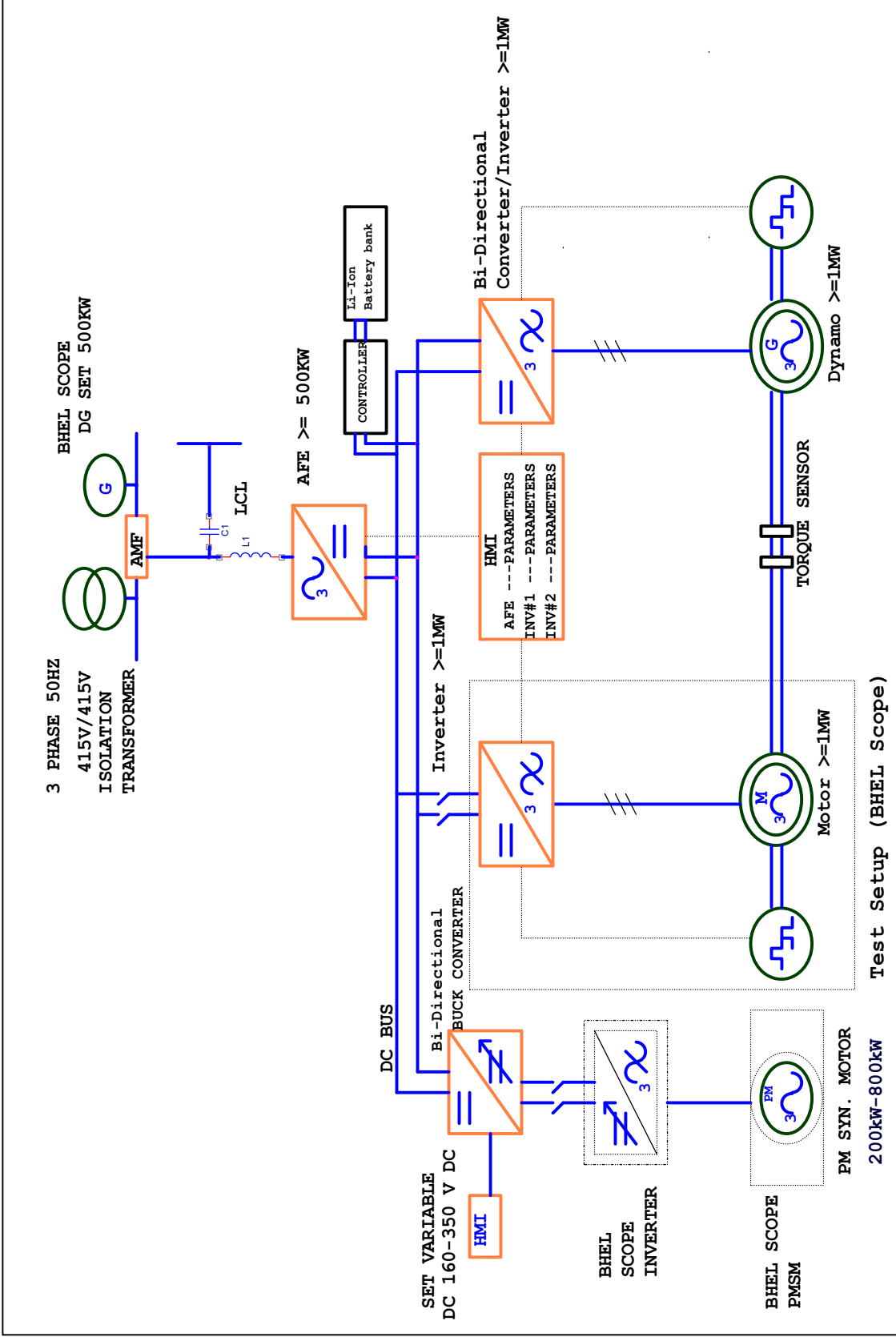

Fig. 3 Schematic of Broad System Topology of Regenerative Test Bed

**Enquiry# 281504151 dated 08-March-2016**

**Annexure - I**

**DETAILS OF COMPANY PERFORMANCE**

**A. Capacity Details:**

Test Bed Systems (Major machines, Controllers with Qty.)	Type of Major Machines	Qty.	Type of Major Drive Controllers	Qty.
Test Bed systems and its associated equipment supplied in last 5 years.	Scheduled Supply Period	Actual Supply Period	Scheduled Supply Period	Actual Supply Period
Outstanding Order Book position (Customer details and Technical details of the Test Bed systems and their associated equipment)				

**B. Performance of supplies to BHEL:**

Details of POs to be considered in last 5 years shall include (i) Last 5 POs fully executed and (ii) all POs overdue for supply and/or E&C. Details of all machines in the POs to be given.

Sl. No.	Name of M/c with broad specs.	Name of BHEL Unit	P.O. No. & Date	P.O. Value	Supply Date		Erection & Commissioning		Reason of delay, if any
					As per P.O.	Actual/ Likely	E&C period incl. job prove out as agreed (in days)	Actual / Likely period of E&C completion (in days)	
(D)	(2)	(3)	(4)	(5)	(6)	(7)	(8)	(9)	(10)
1.									
2.									
3.									
4.									

Note: 1. In case bidder has not received any Purchase Order in the last 5 years from any of the Units of BHEL, then 'NIL' should be indicated.

2. Reasons for delay to be explained in details.

3. BHEL reserves the right to reject the offer, if past performance of the bidder is evaluated to be unsatisfactory and/or false information is given by the bidder.

INTEGRITY PACT

Between

Bharat Heavy Electricals Ltd. (BHEL), a company registered under the Companies Act 1956 and having its registered office at —BHEL House“, Siri Fort, New Delhi œ 110049 (India) hereinafter referred to as —The Principal“, which expression unless repugnant to the context or meaning hereof shall include its successors or assigns of the ONE PART

and

\_\_\_\_\_’,  
(description of the party along with address), hereinafter referred to as —The Bidder/ Contractor“ which expression unless repugnant to the context or meaning hereof shall include its successors or assigns of the OTHER PART.

Preamble

The Principal intends to award, under laid-down organizational procedures, contract/s for

\_\_\_\_\_  
\_\_\_\_\_

\_\_\_\_\_. The Principal values full compliance with all relevant laws of the land, rules and regulations, and the principles of economic use of resources, and of fairness and transparency in its relations with its Bidder(s)/ Contractor(s).

In order to achieve these goals, the Principal will appoint Independent External Monitor(s), who will monitor the tender process and the execution of the contract for compliance with the principles mentioned above.

## **Section 1 - Commitments of the Principal**

1.1 The Principal commits itself to take all measures necessary to prevent corruption and to observe the following principles:-

1.1.1 No employee of the Principal, personally or through family members, will in connection with the tender for, or the execution of a contract, demand, take a promise for or accept, for self or third person, any material or immaterial benefit which the person is not legally entitled to.

1.1.2 The Principal will, during the tender process treat all Bidder(s) with equity and reason. The Principal will in particular, before and during the tender process, provide to all Bidder(s) the same information and will not provide to any Bidder(s) confidential / additional information through which the Bidder(s) could obtain an advantage in relation to the tender process or the contract execution.

1.1.3 The Principal will exclude from the process all known prejudiced persons.

1.2 If the Principal obtains information on the conduct of any of its employees which is a penal offence under the Indian Penal Code 1860 and Prevention of Corruption Act 1988 or any other statutory penal enactment, or if there be a substantive suspicion in this regard, the Principal will inform its Vigilance Office and in addition can initiate disciplinary actions.

## **Section 2 - Commitments of the Bidder(s)/ Contractor(s)**

2.1 The Bidder(s)/ Contractor(s) commit himself to take all measures necessary to prevent corruption. He commits himself to observe the following principles during his participation in the tender process and during the contract execution:-

- 2.1.1 The Bidder(s)/ Contractor(s) will not, directly or through any other person or firm, offer, promise or give to the Principal or to any of the Principal's employees involved in the tender process or the execution of the contract or to any third person any material, immaterial or any other benefit which he / she is not legally entitled to, in order to obtain in exchange any advantage of any kind whatsoever during the tender process or during the execution of the contract.
- 2.1.2 The Bidder(s)/ Contractor(s) will not enter with other Bidder(s) into any illegal or undisclosed agreement or understanding, whether formal or informal. This applies in particular to prices, specifications, certifications, subsidiary contracts, submission or non-submission of bids or any other actions to restrict competitiveness or to introduce cartelization in the bidding process.
- 2.1.3 The Bidder(s)/ Contractor(s) will not commit any penal offence under the relevant IPC/ PC Act; further the Bidder(s)/ Contractor(s) will not use improperly, for purposes of competition or personal gain, or pass on to others, any information or document provided by the Principal as part of the business relationship, regarding plans, technical proposals and business details, including information contained or transmitted electronically.
- 2.1.4 The Bidder(s)/ Contractor(s) will, when presenting his bid, disclose any and all payments he has made, and is committed to or intends to make to agents, brokers or any other intermediaries in connection with the award of the contract.
- 2.2 The Bidder(s)/ Contractor(s) will not instigate third persons to commit offences outlined above or be an accessory to such offences.

### **Section 3 - Disqualification from tender process and exclusion from future contracts**

If the Bidder(s)/ Contractor(s), before award or during execution has committed a transgression through a violation of Section 2 above, or acts in any other manner such as to put his reliability or credibility in question, the Principal is entitled to disqualify the bidder(s)/ Contractor(s) from the tender process or take action as per the separate "Guidelines on Banning of Business dealings with Suppliers/ Contractors" framed by the Principal.

### **Section 4 - Compensation for Damages**

4.1 If the Principal has disqualified the Bidder from the tender process prior to the award according to Section 3, the Principal is entitled to demand and recover the damages equivalent Earnest Money Deposit/Bid Security.

4.2 If the Principal has terminated the contract according to Section 3, or if the Principal is entitled to terminate the contract according to section 3, the Principal shall be entitled to demand and recover from the Contractor liquidated damages equivalent to 5% of the contract value or the amount equivalent to Security Deposit/Performance Bank Guarantee, whichever is higher.

### **Section 5 - Previous Transgression**

5.1 The Bidder declares that no previous transgressions occurred in the last 3 years with any other company in any country conforming to the anti-corruption approach or with any other Public Sector Enterprise in India that could justify his exclusion from the tender process.

5.2 If the Bidder makes incorrect statement on this subject, he can be disqualified from the tender process or the contract, if already awarded, can be terminated for such reason.

## **Section 6 - Equal treatment of all Bidders/ Contractors/ Sub-contractors**

- 6.1 The Bidder(s)/ Contractor(s) undertake(s) to obtain from all subcontractors a commitment consistent with this Integrity Pact and report Compliance to the Principal. This commitment shall be taken only from those sub-contractors whose contract value is more than 20 % of Bidder's/ Contractor's contract value with the Principal. The Bidder(s)/ Contractor(s) shall continue to remain responsible for any default by his Sub-contractor(s).
- 6.2 The Principal will enter into agreements with identical conditions as this one with all Bidders and Contractors.
- 6.3 The Principal will disqualify from the tender process all bidders who do not sign this pact or violate its provisions.

## **Section 7-Criminal Charges against violating Bidders/Contractors/Sub-contractors**

If the Principal obtains knowledge of conduct of a Bidder, Contractor or Subcontractor, or of an employee or a representative or an associate of a Bidder, Contractor or Subcontractor which constitutes corruption, or if the Principal has substantive suspicion in this regard, the Principal will inform the Vigilance Office.

## **Section 8 -Independent External Monitor(s)**

- 8.1 The Principal appoints competent and credible Independent External Monitor for this Pact. The task of the Monitor is to review independently and objectively, whether and to what extent the parties comply with the obligations under this agreement.
- 8.2 The Monitor is not subject to instructions by the representatives of the parties and performs his functions neutrally and independently. He reports to the CMD, BHEL.

- 8.3 The Bidder(s)/ Contractor(s) accepts that the Monitor has the right to access without restriction to all contract documentation of the Principal including that provided by the Bidder(s)/ Contractor(s). The Bidder(s)/ Contractor(s) will grant the monitor, upon his request and demonstration of a valid interest, unrestricted and unconditional access to his contract documentation. The same is applicable to Sub-contractor(s). The Monitor is under contractual obligation to treat the information and documents of the Bidder(s)/ Contractor(s) / Sub-contractor(s) with confidentiality.
- 8.4 The Principal will provide to the Monitor sufficient information about all meetings among the parties related to the contract provided such meetings could have an impact on the contractual relations between the Principal and the Contractor. The parties offer to the Monitor the option to participate in such meetings.
- 8.5 As soon as the Monitor notices, or believes to notice, a violation of this agreement, he will so inform the Management of the Principal and request the Management to discontinue or take corrective action, or heal the situation, or to take other relevant action. The Monitor can in this regard submit non-binding recommendations. Beyond this, the Monitor has no right to demand from the parties that they act in a specific manner, refrain from action or tolerate action.
- 8.6 The Monitor will submit a written report to the CMD, BHEL within 8 to 10 weeks from the date of reference or intimation to him by the Principal and, should the occasion arise, submit proposals for correcting problematic situations.
- 8.7 The CMD, BHEL shall decide the compensation to be paid to the Monitor and its terms and conditions.
- 8.8 If the Monitor has reported to the CMD, BHEL, a substantiated suspicion of an offence under relevant IPC / PC Act, and the CMD, BHEL has not, within reasonable time, taken visible action to proceed against such offence or reported it to the Vigilance Office, the Monitor may also transmit this information directly to the Central Vigilance Commissioner, Government of India.

8.9 The number of Independent External Monitor(s) shall be decided by the CMD, BHEL.

8.10 The word "Monitor" would include both singular and plural.

### **Section 9 - Pact Duration**

9.1 This Pact begins and shall be binding on and from the submission of bid(s) by bidder(s). It expires for the Contractor 12 months after the last payment under the respective contract and for all other Bidders 6 months after the contract has been awarded.

9.2 If any claim is made / lodged during this time, the same shall be binding and continue to be valid despite the lapse of this pact as specified as above, unless it is discharged/ determined by the CMD, BHEL.

### **Section 10 - Other Provisions**

10.1 This agreement is subject to Indian Laws and jurisdiction shall be registered office of the Principal, i.e. New Delhi.

10.2 Changes and supplements as well as termination notices need to be made in writing. Side agreements have not been made.

10.3 If the Contractor is a partnership or a consortium, this agreement must be signed by all partners or consortium members.

10.4 Should one or several provisions of this agreement turn out to be invalid, the remainder of this agreement remains valid. In this case, the parties will strive to come to an agreement to their original intentions.

10.5 Only those bidders/ contractors who have entered into this agreement with the Principal would be competent to participate in the bidding. In other words, entering into this agreement would be a preliminary qualification.

-----  
For & On behalf of the Principal  
(Office Seal)

-----  
For & On behalf of the Bidder/ Contractor  
(Office Seal)

Place-----

Date-----

Witness: \_\_\_\_\_

Witness: \_\_\_\_\_

(Name & Address) \_\_\_\_\_  
\_\_\_\_\_

(Name & Address) \_\_\_\_\_  
\_\_\_\_\_

## PROFORMA OF CONTRACT EXECUTION BANK GUARANTEE (CEBG)

In consideration of the Bharat Heavy Electricals Limited <sup>1</sup> (hereinafter referred to as the 'Employer' which expression shall unless repugnant to the context or meaning thereof, include its successors and permitted assigns) incorporated under the Companies Act, 1956 and having its registered office at \_\_\_\_\_ through its Unit at.....(name of the Unit) having agreed to accept ( Name of the Vendor / Contractor / Supplier) having its registered office at \_\_\_\_\_ <sup>2</sup> (hereinafter called the said Contractor which term includes supplier), under the terms and conditions of the Contract reference No. \_\_\_\_\_ dated \_\_\_\_\_ <sup>3</sup> valued at Rs.....<sup>4</sup> ( Rupees -----)<sup>4</sup> (hereinafter called the said Contract) of Contract Execution Bank Guarantee for the due fulfilment by the said contractor of the terms and conditions contained in the said Contract, on production of a Bank Guarantee for Rs. \_\_\_\_\_ <sup>5</sup> (Rupees \_\_\_\_\_ only), we \_\_\_\_\_ (indicate the name and address of the Bank) having its Head Office at \_\_\_\_\_ (address of the head Office) (hereinafter referred to as the Bank) at the request of \_\_\_\_\_ [Contractor(s)] do hereby undertake to pay to the Employer an amount not exceeding Rs. \_\_\_\_\_ in the event of any breach by the said Contractor(s) of any of the terms and conditions contained in the said Contract.

We, \_\_\_\_\_ (indicate the name of the Bank), do hereby undertake to pay the amounts due and payable under this guarantee without any demur, merely on a demand from the Employer. Any such demand made on the bank, shall be conclusive as regards the amount due and payable by the Bank under this guarantee. However, our liability under this guarantee shall be restricted to an amount not exceeding Rs. \_\_\_\_\_.

We undertake to pay to the Employer any money so demanded notwithstanding any dispute or disputes raised by the Contractor(s) in any suit or proceeding pending before any Court or Tribunal relating thereto our liability under this present being absolute and unequivocal.

The payment so made by us under this guarantee shall be a valid discharge of our liability for payment hereunder and the Contractor(s) shall have no claim against us for making such payment.

We, further agree that the guarantee herein contained shall remain in full force and effect during the period that would be taken for the performance of the said Contract and that it shall continue to be enforceable till erection and commissioning is completed and Performance Bank guarantee is submitted or till \_\_\_\_\_<sup>6</sup> office/Department/Division of Bharat Heavy Electricals Limited certifies that the terms and conditions of the said Contract have been fully and properly carried out by the said contractor(s) and also including the satisfactory commissioning of the equipment and accordingly discharges this guarantee. Unless a demand or claim under this guarantee is made on us in writing on or before the \_\_\_\_\_<sup>7</sup>, we shall be discharged from all the liability under this guarantee thereafter.

We, \_\_\_\_\_ (indicate the name of the Bank) \_\_\_\_\_ further agree with the Employer that the Employer shall have the fullest liberty without our consent and without affecting in any manner our obligations hereunder to vary any of the terms and conditions of the said Contract or to extend time of performance by the said contractor(s) from time to time or to postpone for any time or from time to time any of the powers exercisable by the Employer against the said contractor(s) and to forbear or enforce any of the terms and conditions relating to the said Contract and we shall not be relieved from our liability by any reason of any such variation or extension being granted to the said contractor(s) or for any forbearance, act or omission on the part of the Employer or any indulgence by the Employer to the said contractor(s) or by any such matter or thing whatsoever which under the law relating to sureties would but for this provision have effect of so relieving us.

This guarantee will not be discharged due to the change in the constitution of the Bank or the Contractor(s).

We,..... BANK lastly undertake not to revoke this guarantee during its currency except with the previous consent of the Employer in writing.

Notwithstanding anything to the contrary contained hereinabove:

- a) The liability of the Bank under this Guarantee shall not exceed.....<sup>8</sup>
- b) This Guarantee shall be valid up to .....<sup>9</sup>
- c) Unless the Bank is served a written claim or demand on or before \_\_\_\_\_<sup>10</sup> all rights under this guarantee shall be forfeited and the Bank shall be relieved and discharged from all liabilities under this guarantee irrespective of whether or not the original bank guarantee is returned to the Bank.

We, \_\_\_\_\_ (indicate the name of the Bank) \_\_\_\_\_ lastly undertake not to revoke this guarantee during its currency except with the previous consent of the Employer in writing.

Date \_\_\_\_\_ Day of \_\_\_\_\_  
for \_\_\_\_\_ (indicate the name of the Bank) \_\_\_\_\_

(Signature of Authorised signatory)

\* This date to be indicated should not be earlier than 60 days after the date contemplated under the contract.

<sup>1</sup> NAME AND ADDRESS OF THE EMPLOER. I.e Bharat Heavy Electricals Limited

<sup>2</sup> NAME AND ADDRESS OF THE VENDOR /CONTRACTOR / SUPPLIER .

<sup>3</sup> DETAILS ABOUT THE NOTICE OF AWARD/CONTRACT REFERENCE

<sup>4</sup> PROJECT/SUPPLY DETAILS

<sup>5</sup> BG AMOUNT IN FIGURES AND WORDS

<sup>6</sup> VALIDITY DATE

<sup>7</sup> DATE OF EXPIRY OF CLAIM PERIOD

<sup>8</sup> BG AMOUNT IN FIGURES AND WORDS.

<sup>9</sup> VALIDITY DATE

<sup>10</sup> DATE OF EXPIRY OF CLAIM PERIOD

**BANK GUARANTEE FOR PERFORMANCE SECURITY (PBG)**

Bank Guarantee No:

Date:

To

NAME

& ADDRESSES OF THE BENEFICIARY

Dear Sirs,

In consideration of the Bharat Heavy Electricals Limited <sup>1</sup> (hereinafter referred to as the 'Employer' which expression shall unless repugnant to the context or meaning thereof, include its successors and permitted assigns) incorporated under the Companies Act, 1956 and having its registered office at \_\_\_\_\_ through its Unit at.....(name of the Unit) having awarded to (Name of the Vendor / Contractor / Supplier) having its registered office at \_\_\_\_\_ <sup>2</sup> hereinafter referred to as the 'Contractor/Supplier', which expression shall unless repugnant to the context or meaning thereof, include its successors and permitted assigns), a contract Ref No.....dated ..... <sup>3</sup> valued at Rs..... <sup>4</sup> ( Rupees -----) /FC.....(in words.....) for ..... <sup>5</sup> (hereinafter called the 'Contract') and the Contractor having agreed to provide a Contract Performance Guarantee, equivalent to .....% (.... Percent) of the said value of the Contract to the Employer for the faithful performance of the Contract,

we, ....., (hereinafter referred to as the Bank), having registered/Head office at ..... and inter alia a branch at ..... being the Guarantor under this Guarantee, hereby, irrevocably and unconditionally undertake to forthwith and immediately pay to the Employer a maximum amount Rs ----- ( Rupees -----) without any demur, immediately on a demand from the Employer, .

Any such demand made on the Bank shall be conclusive as regards the amount due and payable by the Bank under this guarantee. However, our liability under this guarantee shall be restricted to an amount not exceeding Rs. \_\_\_\_\_.

We undertake to pay to the Employer any money so demanded notwithstanding any dispute or disputes raised by the Contractor/ Supplier in any suit or proceeding pending before any Court or Tribunal relating thereto our liability under this present being absolute and unequivocal.

The payment so made by us under this Guarantee shall be a valid discharge of our liability for payment thereunder and the contractors/supplier shall have no claim against us for making such payment.

We the .....bank further agree that the guarantee herein contained shall remain in full force and effect during the period that would be taken for the performance of the said Contract and that it shall continue to be enforceable till all the dues of the Employer under or by virtue of the said Contract have been fully paid and its claims satisfied or discharged.

We ..... BANK further agree with the Employer that the Employer shall have the fullest liberty without our consent and without affecting in any manner our obligations hereunder to vary any of the terms and conditions of the said Contract or to extend time of performance by the said Contractor/Supplier from time to time or to postpone for any time or from time to time any of the powers exercisable by the Employer against the said Contractor/Supplier and to forbear or enforce any of the terms and conditions relating to the said Agreement and we shall not be relieved from our liability by reason of any such variation, or extension being granted to the said Contractor/Supplier or for any forbearance, act or omission on the part of the Employer or any indulgence by the Employer to the said Contractor/Supplier or by any such matter or thing whatsoever which under the law relating to sureties would but for this provision have effect of so relieving us.

The Bank also agrees that the Employer at its option shall be entitled to enforce this Guarantee against the Bank as a principal debtor, in the first instance without proceeding against the Contractor and notwithstanding any security or other guarantee that the Employer may have in relation to the Contractor's liabilities.

This Guarantee shall remain in force upto and including.....<sup>6</sup> and shall be extended from time to time for such period as may be desired by Employer.

This Guarantee shall not be determined or affected by liquidation or winding up, dissolution or change of constitution or insolvency of the Contractor/Supplier but shall in all respects and for all purposes be binding and operative until payment of all money payable to the Employer in terms thereof.

Unless a demand or claim under this guarantee is made on us in writing on or before the .....<sup>7</sup>we shall be discharged from all liabilities under this guarantee thereafter.

We, ..... BANK lastly undertake not to revoke this guarantee during its currency except with the previous consent of the Employer in writing.

Notwithstanding anything to the contrary contained hereinabove:

- a) The liability of the Bank under this Guarantee shall not exceed.....<sup>8</sup>
- b) This Guarantee shall be valid up to .....<sup>9</sup>
- c) Unless the Bank is served a written claim or demand on or before \_\_\_\_\_<sup>10</sup> all rights under this guarantee shall be forfeited and the Bank shall be relieved and discharged from all liabilities under this guarantee irrespective of whether or not the original bank guarantee is returned to the Bank.

We, \_\_\_\_\_ Bank, have power to issue this Guarantee under law and the undersigned as a duly authorized person has full powers to sign this Guarantee on behalf of the Bank.

For and on behalf of  
  
(Name of the Bank)

Dated.....

Place of Issue.....

<sup>1</sup> NAME AND ADDRESS OF EMPLOYER I.e Bharat Heavy Electricals Limited

<sup>2</sup> NAME AND ADDRESS OF THE VENDOR /CONTRACTOR / SUPPLIER.

<sup>3</sup> DETAILS ABOUT THE NOTICE OF AWARD/CONTRACT REFERENCE

<sup>4</sup> PROJECT/SUPPLY DETAILS

<sup>5</sup> BG AMOUNT IN FIGURES AND WORDS

<sup>6</sup> VALIDITY DATE

<sup>7</sup> DATE OF EXPIRY OF CLAIM PERIOD

<sup>8</sup> BG AMOUNT IN FIGURES AND WORDS.

<sup>9</sup> VALIDITY DATE

<sup>10</sup> DATE OF EXPIRY OF CLAIM PERIOD

**Note:**

1. Expiry of claim period is 2 months after validity date. Validity date: Warrantee period + 1 month
2. In Case of Bank Guarantees submitted by Foreign Vendors-
  - a. **From Nationalized/Public Sector / Private Sector/ Foreign Banks (BG issued by Branches in India)** can be accepted subject to the condition that the Bank Guarantee should be enforceable in the town/city or at nearest branch where the Unit is located i.e. Demand can be presented at the Branch located in the town/city or at nearest branch where the Unit is located.
  - b. **From Foreign Banks (wherein Foreign Vendors intend to provide BG from local branch of the Vendor country's Bank)**
    - b.1 In such cases, in the Tender Enquiry/ Contract itself, it may be clearly specified that Bank Guarantee issued by **any of the Consortium Banks only** will be accepted by BHEL. As such, Foreign Vendor needs to make necessary arrangements for issuance of Counter-Guarantee by Foreign Bank in favour of the Indian Bank (BHEL's Consortium Bank). It is advisable that all charges for issuance of Bank Guarantee/ counter- Guarantee should be borne by the Foreign Vendor. The tender stipulation should clearly specify these requirements.
    - b.2 **In case, Foreign Vendors intend to provide BG from Overseas Branch of our Consortium Bank (e.g. if a BG is to be issued by SBI Frankfurt), the same is acceptable. However, the procedure at sl.no. b.1 will required to be followed.**

- b.3** The BG issued may preferably be subject to Uniform Rules for Demand Guarantees (URDG) 758 (as amended from time to time). In case, of Foreign Vendors, the BG Format provided to them should clearly specify the same.
- b.4** The BG should clearly specify that the demand or other document can be presented in electronic form.

<b>List of Consortium Banks</b>			
<b>A</b>	<b>Nationalised Banks</b>	<b>B</b>	<b>Public Sector Banks</b>
1	Allahabad bank	20	IDBI
2	Andhra bank	C	<b>Foreign banks</b>
3	Bank of Baroda	21	CITI Bank N.A
4	Canara Bank	22	Deutsche Bank AG
5	Corporation bank	23	The Hongkong and Shanghai Banking Corporation Limited
6	Central bank	24	Standard Chartered Bank
7	Indian Bank	25	The Royal Bank of Scotland N.V.
8	Indian Oversea Bank	26	J P Morgan
9	Oriental bank of Commerce	D	<b>Private bank</b>
10	Punjab National Bank	27	Axis Bank
11	Punjab & Sindh Bank	28	The Federal Bank Limited
12	State Bank of India	29	HDFC
13	State Bank of Hyderabad	30	Kotak Mahindra Bank
14	Syndicate Bank	31	ICICI
15	State Bank of Travancore	32	Indusind Bank
16	UCO Bank	33	Yes Bank
17	Union Bank of India		
18	United Bank of India		
19	Vijaya Bank		



**BHEL R&D**

## **Terms & Conditions of Reverse Auction**

Against this enquiry for the subject item/ system with detailed scope of supply as per enquiry specifications, BHEL may resort to "REVERSE AUCTION PROCEDURE" i.e., ON LINE BIDDING (THROUGH A SERVICE PROVIDER). The philosophy followed for reverse auction shall be English Reverse (No ties).

1. For the proposed reverse auction, technically and commercially acceptable bidders only shall be eligible to participate.
2. Those bidders who have given their acceptance for Reverse Auction (quoted against this tender enquiry) will have to necessarily submit „online sealed bid? in the Reverse Auction. Non-submission of „online sealed bid? by the bidder for any of the eligible items for which techno-commercially qualified, will be considered as tampering of the tender process and will invite action by BHEL as per extant guidelines in vogue.
3. BHEL will engage the services of a service provider who will provide all necessary training and assistance before commencement of on line bidding on internet.
4. In case of reverse auction, BHEL will inform the bidders the details of Service Provider to enable them to contact & get trained.
5. Business rules like event date, time, bid decrement, extension etc. also will be communicated through service provider for compliance.
6. Bidders have to fax the Compliance form (annexure IV) before start of Reverse auction. Without this, the bidder will not be eligible to participate in the event.
7. In line with the NIT terms, BHEL will provide the calculation sheet (e.g., EXCEL sheet) which will help to arrive at "Total Cost to BHEL" like Packing & forwarding charges, Taxes and Duties, Freight charges, Insurance, Service Tax for Services and loading factors (for non-compliance to BHEL standard Commercial terms & conditions) for each of the bidder to enable them to fill-in the price and keep it ready for keying in during the Auction.
8. Reverse auction will be conducted on scheduled date & time.
9. At the end of Reverse Auction event, the lowest bidder value will be known on auction portal.
10. The lowest bidder has to fax/e-mail the duly signed and filled-in prescribed format for price breakup including that of line items, if required, (Annexure VII) as provided on case-to-case basis to Service provider within two working days of Auction without fail.
11. In case BHEL decides not to go for Reverse Auction procedure for this tender enquiry, the Price bids and price impacts, if any, already submitted and available with BHEL shall be opened as per BHEL's standard practice.
12. Bidders shall be required to read the "Terms and Conditions" section of the auctions site of Service provider, using the Login IDs and passwords given to them by the service provider before reverse auction event. Bidders should acquaint themselves of the „Business Rules of Reverse Auction?, which will be communicated before the Reverse Auction.
13. If the Bidder or any of his representatives are found to be involved in Price manipulation/ cartel formation of any kind, directly or indirectly by communicating with other bidders, action as per extant BHEL guidelines, shall be initiated by BHEL and the results of the RA scrapped/ aborted.
14. The Bidder shall not divulge either his Bids or any other exclusive details of BHEL to any other party.
15. In case BHEL decides to go for reverse auction, the H1 bidder (whose quote is highest in online sealed bid) may not be allowed to participate in further RA process.

**AUTHORISATION LETTER FOR E-PAYMENT/ NEFT / RTGS**  
(PLEASE FILL UP THE FORM COMPLETELY IN CAPITAL LETTERS ON YOUR COMPANY LETTERHEAD ONLY)

Vendor Code (to be filled by BHEL)

Type of Request (Tick one)	NEW	CHANGE
1 Company Name		
2 Address		
3 City with PIN Code		
4 State		
5 PAN Number		
6 TIN/ VAT No.		
7 CST No.		
8 Service Tax No.		
9 Name of Contact Person		
10 Mobile number		
11 Ph. no. with STD Code		
12 Fax No. with STD Code		
13 Email ID		
14 Website (URL)		

**BANK DETAILS FOR EFT / RTGS**

1 Bank Name	
2 Branch	
3 Branch Code	
4 Branch Address	
5 Branch Phone No	
6 Account No.	
7 Account Type: SB/ Current/ other (Specify)	
8 MICR Code	
9 IFSC Code	

I, as an authorized representative / owner of the above named company, hereby state as under:

1. Enclosed here with a cancelled cheque in support of our company's bank details.
2. Authorize BHEL R&D Hyderabad, to electronically make payments to the designated bank account with bank charges, if any, to our account.
3. If the transaction is delayed or not effected at all for reasons of incomplete or incorrect information, I would not hold BHEL / transferring Bank responsible.
4. I hereby certify that the particulars given above are true, complete and correct.
5. This authority remains in full force until BHEL receives and acknowledge written notification requesting change or cancellation.

Date :  
Company  
Seal

Authorised Signatory  
Designation :



Corp. R&D  
DIVISION  
VIKAS NAGAR,

RD:MPX:F-13

## Bharat Heavy Electricals Limited

HYDERABAD- 500 093 (INDIA)  
Ph: 040 - 23772704, Fax: 040 - 23770698, email: mpx@bhelrnd.co.in

### VENDOR REGISTRATION FORM

(Indigenous supplier)

[FORM TO BE SUBMITTED\* BY THE BIDDER ALONG WITH TECHNICAL-BID]

Before filling, please refer to instructions on page-4

#### 1.0 VENDOR PROFILE:

1.1 Name and address of the vendor:

\_\_\_\_\_  
\_\_\_\_\_  
\_\_\_\_\_

Phone Nos.:

Fax No.:

Email: 1.

2.

1.2 Local representative name & address in Hyderabad/Secundrabad :

\_\_\_\_\_  
\_\_\_\_\_  
\_\_\_\_\_

Phone Nos.:

Fax No.:

Email:

Contact Person:

Mobile No.:

#### 2.0 TYPE OF ORGANISATION:

PROPRIETORSHIP	Company:	Sister Concern ( mention vendor registration number of main organization)	
Partnership	CORPORATION	Small Scale Industry	ANY OTHER(Please specify)

In case of SSI unit, copy of registration to be enclosed. It is requested that MSME registration certificate to be enclosed

#### 3.0 ANNUAL TURN OVER:

#	Year	Turn-Over, Rs.
1	Current Year(budgeted)	
2	Previous year ( 200 - 0 )	
3	Prior Year ( 200 - 0 )	

#### 4.0 NAME AND ADDRESS OF THE BANKER:

4.1 Bank Name

4.2 Branch name

4.3 Account number

4.4 Account Type

4.5 MICR Code:

4.6 IFSC Code(RTGS/NEFT):

4.7 Bank Phone number(s),

Blank cheque, duly cancelled, to be enclosed.

Please note that all payments shall be made through Electronic clearance services to your above account against the orders executed, if any.

**5.0 REGISTRATION PARTICULARS**(relevant copies to be enclosed)

- 5.1 IT Permanent Account No.(PAN):
- 5.2 State Sales Tax/VAT Registration No:
- 5.3 Central Sales Tax Registration No:
- 5.4 ED Registration No:
- 5.5 Service Tax Registration No:
- 5.6 PF Account No:
- 5.7 Labour Licence No:
- 5.8 ESI Account No:

**6.0 CONTACT PERSON:** S/Sri:

Designation:

Phone / Mobile No:

**7.0 TOTAL NUMBER OF EMPLOYEES:**

Graduates(Engr/Scientists/Mgmt/Fin.)	Consultants	Workers		
		Sup./Skilled	Semiskilled	Unskilled

**8.0 LIST OF PRODUCTS/ SERVICES OFFERED:**

#	Products/ Services	Capacity
1		
2		
3		
4		
5		
6		

**9.0 REFERENCE LIST :**

(Only recognized public and private sector companies, attach if printed copy available)

#	Customer	Volume / Year
1		
2		
3		
4		
5		
6		
7		

**10.0 INFRASTRUCTURE / FACILITIES:**

#	Facility (with specifications)	Age/ Year procured
1		
2		
3		
4		
5		
6		
7		
8		
9		
10		

**11.0 REGISTRATION WITH OTHER BHEL UNIT/UNITS:**

#	Unit	Registration No	Year
1			
2			
3			
4			

**12.0 ANY OTHER INFORMATION :**

**DECLARATION:**

The information furnished above is true and authentic.

(CEO / PROPRIETOR)

SEAL:

DATE:

Note:

1. Registered bidders, having BHEL (R&D) registration no. or have submitted this format for registration, need not furnish this information again.
2. The competent authority reserves the right to accept or reject the registration.

3. Vendors approved for registration will be informed by mail / email, as convenient. A separate communication will be sent in case of non-registration also, citing reasons thereof.
4. BHEL reserves the right to take penal action as deemed fit if any of the information provided by the vendor(s) is found to be incorrect.
5. AGM, Head (MM) may be contacted for clarification/additional information on registration.

---

Instructions

1. Fill all items. Please mention "N.A." for items/ clauses not applicable.
2. Use A4 sheets for this document and the enclosures. Use of additional sheets is permitted if space provided is not adequate.
3. Attach copies of latest documents in respect of items 5.0 (Registration no.s)
4. Photographs of registered office and the chief executive/proprietor shall be furnished.



RD:MPX:F-14

## Bharat Heavy Electricals Limited

Corp. R&D DIVISION

VIKAS NAGAR,

HYDERABAD- 500 093 (INDIA)

### SUPPLIER REGISTRATION FORM

(FOREIGN SUPPLIER)

ALL COLUMNS SHOULD BE PROPERLY FILLED IN THE SPACE PROVIDED FOR.WHEREVER IT IS NOT APPLICABLE PLEASE WRITE "NOT APPLICABLE".INCOMPLETE OR INCORRECT FORMS MAY NOT BE CONSIDERED.

#### 1.0 GENERAL INFORMATION:

1.1 NAME OF COMPANY

1.2 DETAILS OF HEAD OFFICE:

ADDRESS :  
TELEPHONE :  
FAX :  
EMAIL :  
WEB SITE :

1.3 DETAILS OF FACTORY/WORKS:

ADDRESS :  
TELEPHONE :  
FAX :  
EMAIL :  
WEB SITE :

1.4 DETAILS OF MARKETING AGENT

ADDRESS :  
TELEPHONE :  
FAX :  
EMAIL :  
WEB SITE :

1.5 CHIEF EXECUTIVE

1.6 CONTACT PERSON(S)  
FOR PRODUCT OFFERED

NAME(S) :  
OFFICIAL CPACITY :  
ADDRESS :  
TELEPHONE :  
FAX :  
EMAIL :

1.7 YEAR OF ESTABLISHMENT

1.8 PRODUCTION CAPACITY PER ANNUM

1.9 PARTICULARS OF PRODUCT INCLUDING  
SPECIFICATION AND RANGE OFFERED  
FOR REGISTRTION  
(Attach brochures and catalogues)

1.10 NAME(S) OF BANKERS

1.11 BANKER'S CERTIFICATE

1.12 PORT OF LOADING

1.13 NEAREST AIRPORT

1.14 NAME OF THE INDIAN AGENT, IF ANY  
WITH AUTHORIZATION LETTER

#### 2.0 FINANCIAL INFORMATION:

2.1 TOTAL CAPACITY





RD:MPX:F-13

## **Bharat Heavy Electricals Limited**

Corp. R&D DIVISION

VIKAS NAGAR,

HYDERABAD- 500 093 (INDIA)

Ph: 040 – 23772704, Fax: 040 – 23770698, email: [mpx@bhelrnd.co.in](mailto:mpx@bhelrnd.co.in)

---

### **GUIDE LINES REGARDING DEALINGS WITH INDIAN AGENTS OF FOREIGN SUPPLIERS**

- i. BHEL shall deal directly with foreign vendors, wherever required, for procurement of goods. However, if the foreign principal desires to avail of the services of an Indian agent, then the foreign principal should ensure compliance to regulatory guidelines - which require mandatory submission of an Agency Agreement.
- ii. It shall be incumbent on the Indian agent and the foreign principal to adhere to the relevant guidelines of Government of India, issued from time to time.
- iii. The Agency Agreement should specify the precise relationship between the foreign OEM / foreign principal and their Indian agent and their mutual interest in the business. All services to be rendered by agent/ associate, whether of general nature or in relation to the particular contract, must be clearly stated by the foreign supplier/ Indian agent. Any payment, which the agent or associate receives in India or abroad from the OEM, whether as commission or as a general retainer fee should be brought on record in the Agreement and be made explicit in order to ensure compliance to laws of the country.
- iv. Any agency commission to be paid by BHEL to the Indian agent shall be in Indian currency only.
- v. Whenever Indian agents are representing on behalf of their principals the relevant authorisation letter and agreement copy to be enclosed along with Technical bid to consider the offer.