



RD:DP:MPX:F-04

Ref: 481402721

BHARAT HEAVY ELECTRICALS LIMITED
CORPORATE RESEARCH & DEVELOPMENT DIVISION
VIKASNAGAR, HYDERABAD - 500 093, INDIA

PHONES:23774494 (EXT:9804)

FAX : 91 40 23770698

ENQUIRY

Date 05-12-2014

Enquiry for **Manufacturing, supply and erection of Floating pontoons and solar panel support structures.**

Enquiry No:481402721

Enquiry Date : 09-12-2014

Due Date: 30-12-2014

Indicative Delivery Date : 16-02-2015

Sl.No	Item Description	Unit	Qty
1	Floating pontoons with accessories and solar panel supporting structures	SET	1

Please submit your quotation for the above material in sealed cover superscribed with enquiry no, enquiry date and due date subject to our enclosed terms and conditions. The quotations shall reach us on or before the due date by 12 noon. The tenders can also be dropped in the tender box kept at the security gate,BHEL R&D. In case you are not in position to submit the offer,please send reply suitably specifying the reasons.

Sl.No	Description	Document Ref.
01	Enquiry, General Terms & Conditions, Commercial Terms & Conditions etc.	Volume - 1
02	Technical specifications, Scope of Supply etc.	Volume - 2

A Shankaraiah
Engineer
shankaraiah@bhelrnd.co.in

	ENQUIRY & QUALIFYING CRITERIA	Volume - 1 Enquiry No 481402721
Manufacturing, supply and erection of Floating pontoons and solar panel support structures.		

1	Tendor inviting officer / Authority, Designation and Address	Additional General Manager(MM) BHEL R & D, Vikas Nagar (Near Balanagar), Hyderabad -500093
2	Item Description - Qty	1) Floating pontoons with accessories and solar panel supporting structures - 1 SET
3	Enquiry Reference no.	481402721
4	Indicative Delivery Date	16-02-2015
5	Due date, Time and place for submission of tender	30-12-2014 upto 12 noon. Sealed Quotations shall be addressed to AGM(MM), BHEL R & D Division, Vikas Nagar (Near Balanagar), Hyderabad AP,India Pin - 500 093 Quotations can also be deposited in the Tender box located at Security Gate of BHEL R & D BHEL shall not be responsible for any postal/courier delay.
6	Place, Date and time of Tech.Bid opening	Tender Opening Cell (Sangam) BHEL R & D Office. 30-12-2014, 2 PM
7	Mode of Submission of Tender	<p>Please submit your offer in one common sealed cover containing two parts in separate sealed covers as detailed below.</p> <p>1. First Cover shall contain:</p> <ol style="list-style-type: none"> Technical & Commercial bid. Filled in commercial compliance statement(mandatory) Copy of Price-bid with price(s) cells blank (un-priced price bid) <p>2. Second cover shall contain Price Bid. Price Bid Containing Price quotes, installation and/or commissioning charges shall be spelt out clearly taking into account total charges rather than quoting vaguely such as charges per man-day or charges per engineer per day etc.</p> <p>If the price bid was found later to be different from the unpriced pricebid format in any way, the offer will be rejected summarily. The rates shall be quoted both in figures and in words.</p> <p>The offers can also be submitted through e-mail and have to be sent in PDF format (files with PDF extension only). Files having extensions other than PDF like RAR, EXE,JPEG etc. and with external links will not be considered. They have to be sent to e-mail id: 'eoffers@bhelrnd.co.in' only. Copies should not be marked to anyone. If the offers are marked to anyone other than to eoffers, their offer will not be considered.</p> <p>The e-mail offers should have two attachments. One attachment shall contain a) Technical & Commercial bid b) Filled in Commercial Compliance Statement (mandatory) and c) Copy of price bid with price(s) cells blank (un-priced price bid). The second attachment shall contain price bid.</p> <p>The subject of the e-mail should contain Enquiry No, Enquiry Date and Due date.</p>

	GENERAL TERMS & CONDITIONS (GTC)	Volume - 1 Enquiry No 481402721
Manufacturing, supply and erection of Floating pontoons and solar panel support structures.		

SL.No.	Clause	BHEL REQUIREMENT
1	General	<p>a. All offers must include name of the contact person, phone no/mobile no, Fax no, email-id. Unsigned offers are liable for rejection.</p> <p>b. We, BHEL R&D, is registered with Department of Scientific and Industrial Research (DSIR) for the purpose of availing Customs Duty exemption in terms of Government Notification no.24/2007-Customs dated 01-Mar-2007 & Central Excise Duty Exemption in terms of Government Notification No. 16/2007-Central Excise dated 01-Mar-2007 as amended from time to time. Hence suppliers are requested to submit their bids clearly stating applicable taxes/duties. All foreign quotes will be evaluated with custom duty @ 5.15% for cost comparison.</p> <p>c. Taxes & Duties quoted will be taken for evaluation of landed cost & order placement and no change will be entertained later except in the case of changes made by the government. However please note that we are availing cenvat credit for service tax and hence service tax will be excluded in calculation of landed cost to BHEL.</p> <p>In case any Taxes/ Duties exempted, a self declaration for the same may be attached to the offer. Changes in taxes and duties because of the changes in turn over etc will be to supplier's account.</p> <p>d. Where ever vendor registration form and EFT details have been submitted earlier, the same need not be submitted again unless there is a change.</p> <p>e. BHEL R&D do not issue 'C' form .</p> <p>f. L1 status shall be decided on Cost to BHEL Basis.</p>
2	Foreign Suppliers	<p>BHEL will deal directly with foreign vendors, where ever required, for procurement of goods.However, if the foreign principal desires to avail of services of an Indian agent,then foreign principal should ensure compliance to regulatory guidelines which require mandatory submission of agency agreement containing agency commission.</p> <p>Any supplier (Agents/distributors/representatives) desirous of quoting imported goods/services, they should submit the quote in foreign currency along with agency agreement copy, failing which their offer is liable for rejection.In case of non submission of agency agreement copy,the principal should submit the quotation to BHEL directly. Foreign supplier will also indicate in their offer Indian agent's name, if any, address and percentage of agency commission out of the quoted price.</p> <p>Fully owned Indian Subsidiaries/distributors of Foreign Companies shall quote in Foreign Currency on FOB basis only.</p>
3	Late Tenders	Tenders received after due date/time(12:00hrs) will not be considered
4	Discrepancy in words and figures	<p>(a) If, in the price structure quoted for the required goods/ Services/ works, there is discrepancy between the unit price and the total price (which is obtained by multiplying the unit price by the quantity), the unit price shall prevail and the total price corrected accordingly, unless in the opinion of the purchaser there is an obvious misplacement of the decimal point in the unit price, in which case the total price as quoted shall govern and the unit price corrected accordingly.</p> <p>(b) If there is an error in a total corresponding to the addition or subtraction of subtotals, the subtotals shall prevail and the total shall be corrected; and</p> <p>(c). If there is a discrepancy between words and figures, the amount in words shall prevail, unless the amount expressed in words is related to an arithmetic error, in which case the amount in figures shall prevail subject of (a) and (b) above.</p> <p>(d) If there is such discrepancy in an offer, the same shall be conveyed to the bidder with target date upto which the bidder has to send his acceptance on the above lines and if the bidder does not agree to the decision of the purchaser, the bid is liable to be ignored.</p>
5	Two Part bid clarifications	In the case of Two-part bid, the vendor should furnish technical and commercial clarifications, if any, within stipulated time mentioned, failing which, it will be construed that the vendor is not interested in the tender and BHEL shall not consider the offer for further evaluation.
6	Price Impacts	In the event of any bidder, after finalizing the technical specifications and scope of supply, opting to revise their original bid, they have to submit the Price-Impact only. The Original price bid along with Price-Impact bid shall be opened during price bid opening. Unsolicited price impacts will not be considered.
		All offers in price bid opening or reverse auction shall be evaluated in Indian

7	Price bid evaluation	currency based on unit price, packing & forwarding, taxes/duties, freight charges if any, exchange rate. Loading due to non-acceptance of our standard commercial terms will be evaluated as per the LOADING FACTORS form as enclosed along with the enquiry. The exchange rate declared by State Bank of India under TT Selling rate on the technical bid open date shall be adopted for evaluating foreign currency bids.
8	Packing	The supplier shall be responsible for the goods being properly and adequately packed so as to prevent any loss, damage or deterioration during transit.
9	Withdrawal	In case the supplier withdraws their offer before placement of order, BHEL reserves the right not to send next enquiry(ies). In case the supplier withdraws the quotation after its acceptance by BHEL or fails to supply the goods as per the terms and conditions of contract, or at any time repudiated the contract wholly or in part, BHEL shall be at liberty to cancel the Purchase Order and to recover from the supplier the extra cost and other loss, incidentals due to the breach of contract on the part of the supplier through risk purchase.
10	Risk Purchase	In case of default/late delivery, BHEL reserves the right to make alternate arrangement for procurement at suppliers risk and cost.
11	Banned List	The offers of the bidders who are in the banned list and the offers of the bidders who engage the services of the banned firms, shall be rejected. The list of banned firms is available on BHEL website www.bhel.com.
12	Over All L1	Order will be placed on overall L1 basis. Vendors should quote for all items, otherwise the offer will be rejected.
13	Additional Information	Suppliers are requested to visit our web site regularly for any updates and additional information, "All corrigenda, addenda, amendments, time extensions clarifications, etc. to the tender will be hosted on BHEL website only". The corrigendum will not be published in news paper.
14	Arbitration	Subject to the jurisdiction of Hyderabad/Secunderabad, Andhra Pradesh, India in respect of any suit or other legal proceedings relating this contract.
15	Micro Small Enterprises (MSEs)	<p>In case the supplier belongs to MSEs (Micro Small Enterprises), Registration copy in this respect shall be submitted along with the offer. Further if MSEs are owned by the Scheduled Caste or the Scheduled Tribe entrepreneurs the same may be intimated.</p> <p>The following are the benefits for the MSEs.</p> <ol style="list-style-type: none"> 1. MSEs are given tender documents free of cost and are exempted from payment of earnest money (EMD). 2. In tender, participating MSEs quoting price within price band of L1+15% shall also be allowed to supply a portion of requirement by bringing down their price to L1 price in a situation where L1 price is from someone other than a MSE and such MSE shall be allowed to supply up to 20% of total tendered value. In case of more than one such MSE, the supply shall be shared proportionately. <p>MSE suppliers can avail the intended benefits only if they submit along with offer, attested copies of either EM II certificate having deemed validity (Two years from the date of issue of acknowledgement in EM-II) or valid NSIC certificate or EM II certificate along with CA certificate (Format as below) applicable for the year, certifying quantum of investment in plant and machinery within the permissible limit as per the act for relevant status (Micro or small) Where the deemed validity of EM II is over. Date to be reckoned for determining the deemed validity will be the last date of technical bid submission. Non submission of such documents will lead to consideration of their bids at par with other bidders and MSE status of such suppliers shall be shifted to Non MSE supplier till the supplier submits these documents.</p> <p style="text-align: center;">Certificate by chartered Accountant on letter head</p> <p>This is to certify that M/s, (hereinafter referred to as 'company') having its registered office at is registered under MSMED Act 2006, (Entrepreneur Memorandum No(Part-II) dtd:....., Category:.....(Micro/Small). (Copy enclosed).</p> <p>Further verified from the Books of Accounts that the investment of the company as on date..... as per MSMED Act 2006 is as follows :</p> <ol style="list-style-type: none"> 1. For manufacturing Enterprises : Investment in plant and machinery (i.e. Original cost excluding land and building and the items specified by the ministry of small Scale Industries vide its notification No.S.O.1722(E) dated October 5, 2006. 2. For Service Enterprises : Investment in equipment (Original cost excluding land and building and furniture, fittings and other items not directly related to the service rendered or as may be notified under the MSMED Act, 2006: <p>Rs..... Lacs</p> <p>The above investment of Rs..... Lacs is within permissible limit of Rs..... Lacs forMicro/Small (Strike off</p>

		<p>which is not applicable) Category under MSMED Act 2006.</p> <p>Date:</p> <p>(Signature)</p> <p>Name-</p> <p>Membership number –</p> <p>Seal of Chartered Accountant</p>
16	Inspection	On receipt, the goods shall be subjected to inspection and our decision regarding the acceptability of the goods shall be final and binding on the suppliers.

Signature of the bidder with Seal & Date

	COMMERCIAL TERMS & CONDITIONS (CTC)	Volume - 1 Enquiry No 481402721
Manufacturing, supply and erection of Floating pontoons and solar panel support structures.		

SL.No.	Clause	BHEL REQUIREMENT	SUPPLIERS ACCEPTANCE / REMARKS
1	Reverse Auction	<p>BHEL reserves the right to go for Reverse Auction (RA) instead of opening the sealed envelope price bid, submitted by the bidder. This will be decided after techno-commercial evaluation. All bidders to give their acceptance for participation in RA. Non-acceptance to participate in RA may result in non-consideration of their bids, in case BHEL decides to go for RA.</p> <p>In case BHEL decides to go for Reverse Auction, only those bidders who have given their acceptance to participate in RA will be allowed to participate in the Reverse Auction. Those bidders who have given their acceptance to participate in Reverse Auction will have to necessarily submit „online sealed bid" in the Reverse Auction.</p> <p>Non-submission of „online sealed bid" by the bidder will be considered as tampering of the tender process and will invite action by BHEL as per extant guidelines in vogue.</p>	
2	Two part	<p>Please submit your offer in one common sealed cover containing two parts in separate sealed covers as detailed below.</p> <p>1. First Cover shall contain:</p> <ol style="list-style-type: none"> Technical & Commercial bid. Filled in commercial compliance statement(mandatory) Copy of Price-bid with price(s) cells blank (un-priced price bid) <p>2. Second cover shall contain Price Bid. Price Bid Containing Price quotes, installation and/or commissioning charges shall be spelt out clearly taking into account total charges rather than quoting vaguely such as charges per man-day or charges per engineer per day etc.</p> <p>If the price bid was found later to be different from the unpriced pricebid format in any way, the offer will be rejected summarily. The rates shall be quoted both in figures and in words.</p> <p>The offers can also be submitted through e-mail and have to be sent in PDF format (files with PDF extension only). Files having extensions other than PDF like RAR, EXE,JPEG etc. and with external links will not be considered. They have to be sent to e-mail id: 'eoffers@bhelrnd.co.in' only. Copies should not be marked to anyone. If the offers are marked to anyone other than to eoffers, their offer will not be considered.</p> <p>The e-mail offers should have two attachments. One attachment shall contain a) Technical & Commercial bid b) Filled in Commercial Compliance Statement (mandatory) and c) Copy of price bid with price(s) cells blank (un-priced price bid). The second attachment shall contain price bid.</p> <p>The subject of the e-mail should contain Enquiry No, Enquiry Date and Due date.</p>	
3	Weight and Packing Dimensions.	The Supplier shall indicate the shipping weight (Kgs) and dimensions(L x W x H in cms) clearly along with offer.	
4	Validity of Offer	90 days from date of techno-commercial bid opening.	
5	Price basis	<p>The prices shall be firm for entire period of contract.</p> <p>The suppliers shall indicate packing and forwarding charges,if any, separately.</p> <p>All foreign suppliers shall quote the lowest prices on 'FOB-Nearest International Airport/Sea port' basis. An amount of 3% on basic value towards freight and insurance will be added for cost comparison.</p> <p>All Indian suppliers shall quote the lowest prices on 'free delivery at BHEL R&D Stores or F.O.R destination' basis only.</p>	
6	LD Clause	Failure to supply the goods and/or carryout the services within the stipulated delivery date will attract a penalty of 0.5% per week or part thereof for the value of the undelivered portion of the purchase order subject to a maximum of 10% of the total order value.In case of non acceptance to this LD Clause, 10% of basic material cost will be loaded on the quoted prices while cost comparison.(Please refer the enclosed 'Loading Factors' sheet).	
7	Freight & Insurance	Insurance will be arranged by BHEL in case of FCA / FOB basis supplies. In such cases, an amount of 3% towards freight and insurance will be added for cost comparison	

8	Agency Agreement	<p>Guidelines regarding dealing with Indian agents of foreign suppliers</p> <ol style="list-style-type: none"> 1. BHEL shall deal directly with foreign vendors, where ever required, for procurement of goods. However, if the foreign principal desires to avail of services of an Indian agent, then the foreign principal should ensure compliance to regulatory guidelines which require mandatory submission of agency agreement. 2. It shall be incumbent on the Indian agent and the foreign principal to adhere to the relevant guidelines of government of India, issued from time to time. 3. The agency agreement should specify the precise relationship between the foreign OEM and services to be rendered by agent / associate, whether general in nature or in relation to the particular contract, must clearly stated by the foreign supplier / Indian agent. Any payment, which the agent / associate receives in India or abroad from the OEM, whether as commission or as a general retainer fee shall be brought out in record in the agreement and be made explicit in order to ensure compliance to the laws of the country. 4. Any agency commission to be paid by BHEL to the Indian agent shall be Indian currency. 5. When ever Indian agents are representing on behalf of their principals, the relevant authorization letter and agreement copy to be enclosed along with technical bid to consider the offer. 	
9	Delivery Period	<p><u>FOR INDIAN SUPPLIES :</u></p> <p>Suppliers are requested to quote for the delivery mentioned in the enquiry. However, in case it is not possible to meet the delivery requirement of BHEL, they shall mention in the right column the best possible delivery period</p> <ol style="list-style-type: none"> 1) From date of Purchase order =====> 2) From receipt of material / input data / drawings etc. from BHEL=====> (if applicable) 3) From receipt of approval of design documents / drawings etc. by BHEL=====> (if applicable) 4) Time from PDI to despatch =====> (if applicable) <p>However BHEL shall inform the vendor about rejection of the offer before price bid opening in case of not meeting the delivery requirements of BHEL.</p> <p>=====</p> <p><u>FOR FOREIGN SUPPLIES :</u></p> <p>Suppliers are requested to quote for the delivery mentioned in the enquiry. However, in case it is not possible to meet the delivery requirement of BHEL, they shall mention in the right column the best possible delivery period</p> <ol style="list-style-type: none"> 1. From date of Purchase order :=====> 2. From receipt of input data / drawings etc. from BHEL=====> (if applicable) 3. From receipt of approval of design documents / drawings etc. by BHEL=====> (if applicable) 4. From date of LC Opening=====> (if applicable) 5. From date of PO acceptance =====> (wherever issues like export clearance etc. are involved, mentioning the reasons) <p>However BHEL shall inform the vendor about rejection of the offer before price bid opening in case of not meeting the delivery requirements of BHEL.</p>	
		<p>All Indian suppliers shall clearly mention current sales tax/VAT,Excise duty and Service Tax etc, if any,payable in addition to the quoted price and indicate applicable rates/percentage,item-wise clearly.The vendors should mention applicable Registration</p>	

10	Taxes and duties	Number(s) specifically in their quotation. The suppliers are requested to submit their bids clearly stating applicable taxes and duties. The quoted taxes/duties will be taken for cost evaluation and order placement and no change will be entertained later except in the case of changes made by the government. Please note that we are availing cenvat credit for service tax and hence service tax will be excluded in calculation of landed cost to BHEL. However Proof of payment of service tax is required to be submitted for reimbursement of the same.	
11	Payment Terms	<p>Payment</p> <p>1) Through L/C: Please note Payment through Letter of Credit (L/C) is for foreign currency payments only. Where the payments are through L/C (L/C opening charges shall be loaded for landed cost evaluation), payment of Supply value shall be 80% on dispatch and 20% on issue of E&C Certificate. Payment of E&C Value shall be made against E&C certificate issued by BHEL. E&C certificate shall be issued on satisfactory completion of erection, commissioning, job proving, performance test, training to operators etc, as envisaged in PO. The L/C shall be opened by BHEL as per following:</p> <p>(i) Within 30 days of receipt of order acceptance, an irrevocable unconfirmed L/C will be opened for 30% of the payment towards supply, due on shipment i.e. 24% of the Supply value of PO (30% of 80%) Not earlier than 60 days before the shipment date, the value of this irrevocable unconfirmed L/C would be enhanced from 24% to 80% of the Supply value of PO The above L/C can be negotiated after the Shipment against submission of B/L or AWB and such other documents as mentioned in the PO. The above L/C will be valid for a period extending 21 days beyond the shipment date for negotiation of documents.</p> <p>(ii) 15 days prior to the scheduled & confirmed arrival of the technicians of supplier with their names, an irrevocable unconfirmed L/C will be opened for a value equal to 20% of the Supply value of PO plus 100% of the E&C value of PO. The validity of L/C would be sufficient to cover the period required for the completion of E&C plus 21 days as negotiation period.</p> <p>This L/C can be negotiated after: (a) Completion of E&C of the equipment in BHEL and against E&C certificate issued by BHEL and (b) Submission of Performance Bank Guarantee (PBG) by Supplier in the prescribed Format valid for 60 days beyond the warranty period, from one of the Consortium Banks of BHEL or from a reputed Bank and confirmed by Consortium Bank of BHEL for 10% of total PO Value. The PBG confirmation charges shall be borne by vendor.</p> <p>2 Direct Payment (foreign and Indian Suppliers): In case of direct payment , 80% payment of Supply value shall be made with in 45 days form the date of receipt of material at BHEL. Balance 20% of supply value plus 100% of the E&C portion of PO Value will be paid against E&C certificate issued by BHEL and submission of Performance Bank Guarantee (PBG) valid for 30 days beyond the warranty period by Supplier from any of the Consortium Banks of BHEL for 10% of total PO Value in the prescribed Format. The PBG confirmation charges shall be borne by vendor.</p> <p>3. Bank Guarantee and Loading against non acceptance of BHEL's Payment Terms: If payment terms as mentioned by BHEL are not agreed by bidder, such bidder have to submit Bank Guarantee at the time of payment/opening of LC in the prescribed Format of the amount, exceeding 80% of the PO value, valid till issue of E&C Certificate for the equipment. However, in no case, payment against dispatch shall exceed 90% of the PO Value.</p> <p>Additionally, for any deviation sought including as mentioned above, in Payment Terms by bidder w.r.t. tender conditions, following loading shall be followed: (A) Benchmark Prime Lending Rate(BPLR)of SBI as applicable on the date of tender opening +2%, for the amount & period of relaxation sought by bidder. (B) On account of payment through LC if insisted by bidder , bank charges shall also be loaded for the deviation in (i) opening of LC by BHEL and (ii) period and amount of LC as per prevailing bank rates.</p>	
12	E&C	Supplier to quote Supply and E&C portion with relevant taxes and time requirement separately. BHEL reserves the right to issue two separate orders.	

Note : All the clauses of the above format should be filled and submitted with the Techno Commercial Bid (Part-1). The filled in BHEL Commercial terms & Conditions format submitted with technical bid, responding to all the clauses duly signed with seal **only shall be considered**. Any other Commercial terms & conditions of bidders entered else where in their offer shall not be considered and are liable for rejection.

Signature of the bidder with Seal & Date

	OTHER TERMS & CONDITIONS	Volume - 1 Enquiry No 481402721
Manufacturing, supply and erection of Floating pontoons and solar panel support structures.		

SL.No.	Clause	BHEL REQUIREMENT	SUPPLIERS ACCEPTANCE / REMARKS
1	Erection and commissioning charges	The estimated percentage of E&C value as per BHEL is 10% of Unit price (Supplies value). E&C value should be quoted (% of exw Unit price) separately by bidders in technical bid. Only in case where quoted value is less than % specified above or separate E&C value is not mentioned in the offer, value for E&C portion shall be deemed to be considered as 10% as above & accordingly supply value will be adjusted from that quoted value and balance will be released as E&C payment as per clause #11, Payment term, under Commercial terms and conditions of enquiry	

Signature of the bidder with Seal & Date

	ITEM SPECIFICATIONS	Volume - 2 Enquiry NO 481402721
---	----------------------------	---------------------------------------

Manufacturing, supply and erection of Floating pontoons and solar panel support structures.

SL.No.	Item		
1	Floating pontoons with accessories and solar panel supporting structures		
sl no	Descriptions	BHEL Specifications	Vendor Specifications/ Deviations
01	HDPE Floating Pontoons	As per the attached doc No: SAG-535-48-11	
02	Fixing pins and other accessories for assembling for the pontoons	As per the attached doc No: SAG-535-48-11	
03	Hand rails	As per the attached doc No: SAG-535-48-11	
04	Stainless steel chain for hand rails	As per the attached doc No: SAG-535-48-11	
05	Mooring system	As per the attached doc No: SAG-535-48-11	
06	Solar panel Support structures	As per the attached doc No: SAG-535-48-11	
07	Support structures for walk way on both sides of the floating platform	As per the attached doc No: SAG-535-48-11	
08	Synthetic Life jackets	As per the attached doc No: SAG-535-48-11	
09	Installation and commissioning at site (Hussainsagar, Near Sanjeevaiah Park, Hyderabad)	As per the attached doc No: SAG-535-48-11	
10	Warranty	As per the attached doc No: SAG-535-48-11	
11	Safety during the erection and commissioning	As per the attached doc No: SAG-535-48-11	
G	General Specifications		
sl no	Descriptions	BHEL Specifications	Vendor Specifications/ Deviations
01	Scope of supply	The quantities given in the specifications for item no 1 to 5 of doc no SAG-535-48-11 is tentative estimate and may vary by 10% either side based on the actual site conditions. Basis of the payment will be the actual quantities of work carried out as measured by the vendor and verified by the purchaser. Any extra quantity required for successful execution of the work has to be supplied and commissioned by the vendor and will be paid at the rates mentioned against each item in the priced bid for item 1 to 5 of Doc No" SAG-535-48-11.	
02	Delivery site	The tentative site is Hussainsagar, Near Sanjeevaiah Park, Hyderabad, Actual Site like Gandipet lake/Saroornagar lake(In and around Hyderabad) will be decided based on availability and will be	

		confirmed before commencement of delivery to successful bidder. Vendor shall intimate BHEL before commencement of despatch for actual site/delivery location.	
03	Manufactures Test Certificate	Manufacturer's Test Certificate required and shall be provided before dispatch.	
04	Spares	Offer shall include all the spares required for normal operation of equipment.	
05	Accessories	Offer shall include all the accessories required for normal operation of equipment.	
06	Sub Contracting	In case of further subcontracting of BHEL order or part there of is envisaged by supplier, the same can be done after obtaining written permission from BHEL. However it shall not absolve the responsibility of fulfilling BHEL purchase order requirements.	

* Vendors are advised to write specifications in detail and not to write like 'Complied/ Yes / No ' etc. in specifications.

Signature of the bidder with Seal & Date

BHEL R&D
RD:DP:MPX:F-22

LOADING FACTORS



NOTE : IN CASE OF DEVIATION TO BHEL TENDER SPECIFIED TERMS, LOADING FACTOR INDICATED IN FOLLOWING TABLE WILL BE APPLIED TO QUOTED PRICE WHILE EVALUATING THE LOWEST QUOTE

A. FOR INDIGENOUS PURCHASES					
SLNO	SCOPE	COMMERCIAL TERMS	BHEL STANDARD TERM	AS OFFERED	LOADING FACTOR FOR NON COMPLIANCE TO BHEL STANDARD TERMS
A.1	SUPPLY OF EQUIPMENT INCLUDING ERECTION AND COMMISSIONING (E&C)	PAYMENT TERMS	DIRECT PAYMENT: 80% PAYMENT OF SUPPLY VALUE SHALL BE MADE WITHIN 45 DAYS FROM THE DATE OF RECEIPT OF MATERIAL AT BHEL. BALANCE 20% OF SUPPLY VALUE PLUS 100% OF THE E&C PORTION OF PO VALUE WILL BE PAID AGAINST E&C CERTIFICATE ISSUED BY BHEL AND SUBMISSION OF PERFORMANCE BANK GUARANTEE (PBG) VALID FOR 60 DAYS BEYOND THE WARRANTY PERIOD BY SUPPLIER FROM ANY OF THE CONSORTIUM BANKS OF BHEL FOR 10% OF TOTAL PO VALUE IN THE PRESCRIBED FORMAT. THE PBG CONFIRMATION CHARGES SHALL BE BORNE BY VENDOR	SAME	NO LOADING
				ANY OTHER	SUBMIT BANK GUARANTEE AT THE TIME OF PAYMENT IN THE PRESCRIBED FORMAT OF THE AMOUNT EXCEEDING 80% OF PO VALUE, VALID TILL ISSUE OF E&C CERTIFICATE FOR THE EQUIPMENT. HOWEVER IN NO CASE PAYMENT AGAINST DISPATCH SHALL EXCEED 90% OF THE PO VALUE ADDITIONALLY, LOADING AT BENCHMARK PRIME LENDING RATE(BPLR) OF SBI AS APPLICABLE ON THE SCHEDULED DATE OF TENDER OPENING+2%, FOR THE AMOUNT & PERIOD OF RELAXATION SOUGHT BY BIDDER
B. FOR FOREIGN PURCHASES (IMPORTED)					
			PAYMENT THROUGH LC (LC OPENING CHARGES ARE TO BE LOADED), PAYMENT OF SUPPLY VALUE SHALL BE 80% ON DISPATCH AND 20% ON ISSUE OF E&C CERTIFICATE. PAYMENT OF E&C VALUE SHALL BE MADE AGAINST E&C CERTIFICATE SHALL BE ISSUED BY BHEL. E&C CERTIFICATE SHALL BE ISSUED ON SATISFACTORY COMPLETION OF ERECTION, COMMISSIONING, JOB PROVING, PERFORMANCE TESTS, TRAINING TO OPERATORS ETC AS ENVISAGED IN PO. THE L/C SHALL BE OPENED BY BHEL AS PER FOLLOWING: (i) WITHIN 30 DAYS OF RECEIPT OF ORDER ACCEPTANCE, AN IRREVOCABLE UNCONFIRMED L/C WILL BE OPENED FOR 30% OF THE PAYMENT TOWARDS SUPPLY, DUE ON SHIPMENT I.E., 24% OF THE SUPPLY VALUE OF PO (30% OF 80%) NOT EARLIER THAN 60 DAYS BEFORE THE SHIPMENT DATE, THE VALUE OF THIS IRREVOCABLE UNCONFIRMED L/C WOULD BE ENHANCED FROM 24% TO 80% OF THE SUPPLY VALUE OF PO THE ABOVE L/C CAN BE NEGOTIATED	SAME	NO LOADING
					SUBMIT BANK GUARANTEE AT THE TIME OF OPENING OF LC IN THE PRESCRIBED FORMAT OF THE AMOUNT EXCEEDING 80% OF PO VALUE, VALID TILL ISSUE OF E&C CERTIFICATE FOR THE EQUIPMENT. HOWEVER IN NO CASE PAYMENT AGAINST DISPATCH SHALL EXCEED 90% OF THE PO VALUE. ADDITIONALLY, FOR ANY DEVIATION SOUGHT INCLUDING AS MENTIONED ABOVE, IN PAYMENT TERMS BY BIDDER W.R.T. TENDER CONDITIONS, FOLLOWING LOADING SHALL BE FOLLOWED: (A) BENCHMARK PRIME LENDING RATE(BPLR) OF SBI AS APPLICABLE ON THE SCHEDULED DATE OF TENDER OPENING+2%, FOR THE AMOUNT & PERIOD OF RELAXATION SOUGHT BY BIDDER (B) ON ACCOUNT OF PAYMENT THROUGH LC, IF INSISTED BY BIDDER, BANK CHARGES SHALL ALSO BE LOADED FOR THE DEVIATION IN (i) OPENING OF LC BY BHEL AND (ii) PERIOD AND AMOUNT OF LC W.R.T. NIT NORMS, AS PER THE PREVAILING BANK RATES

B1	SUPPLY OF EQUIPMENT INCLUDING ERECTION AND COMMISSIONING (E&C)	PAYMENT TERMS	<p>AFTER THE SHIPMENT AGAINST SUBMISSION OF B/L OR AWB AND SUCH OTHER DOCUMENTS AS MENTIONED IN THE PO. THE ABOVE L/C WILL BE VALID FOR A PERIOD EXTENDING 21 DAYS BEYOND THE SHIPMENT DATE FOR NEGOTIATION OF DOCUMENTS (ii) 15 DAYS PRIOR TO THE SCHEDULED & CONFIRMED ARRIVAL OF THE TECHNICIANS OF SUPPLIER WITH THEIR NAMES, AN IRREVOCABLE UNCONFIRMED L/C WILL BE OPENED FOR A VALUE EQUAL TO 20% OF THE SUPPLY VALUE OF PO PLUS 100% OF THE E&C VALUE OF PO. THE VALIDITY OF L/C WOULD BE SUFFICIENT TO COVER THE PERIOD REQUIRED FOR THE COMPLETION OF E&C PLUS 21 DAYS AS NEGOTIATION PERIOD. THIS L/C CAN BE NEGOTIATED AFTER: (a) COMPLETION OF E&C OF THE EQUIPMENT IN BHEL AND AGAINST E&C CERTIFICATE ISSUED BY BHEL AND (b) SUBMISSION OF PERFORMANCE BANK GUARANTEE (PBG) BY SUPPLIER IN THE PRESCRIBED FORMAT VALID FOR 60 DAYS BEYOND THE WARRANTY PERIOD FROM ONE OF THE CONSORTIUM BANKS OF BHEL OR FROM A REPUTED BANK AND CONFIRMED BY CONSORTIUM BANK OF BHEL FOR 10% OF TOTAL PO VALUE. THE PBG CONFIRMATION CHARGES SHALL BE BORNE BY VENDOR.</p>	ANY OTHER	
----	--	---------------	---	-----------	--

C. PENALTY FOR DELAYED DELIVERY (COMMON FOR INDIGENOUS AND IMPORTS)				
SLNO	COMMERCIAL TERMS	BHEL STANDARD TERM	AS OFFERED	LOADING FACTOR FOR NON COMPLIANCE TO BHEL STANDARD TERMS
C	LD CLAUSE	IN THE EVENT OF DELAY IN AGREED CONTRACTUAL DELIVERY, PENALTY OF 0.5% (HALF PERCENT) PER WEEK BUT LIMITED TO A MAX OF 10% OF TOTAL ORDER VALUE WILL BE APPLICABLE	AGREED	NIL
			IF NOT AGREED	LOADING @ 10% OF THE BASIC MATERIAL COST
			IF AGREED FOR X%	LOADING @ (10-X)% OF THE BASIC MATERIAL COST
D. GUARANTEE/WARRANTY PERIOD (COMMON FOR INDIGENOUS AND IMPORTS)				
SLNO	COMMERCIAL TERMS	BHEL STANDARD TERM	AS OFFERED	LOADING FACTOR FOR NON COMPLIANCE TO BHEL STANDARD TERMS
D	GUARANTEE/WARRANTY PERIOD	STANDARD GUARANTEE/ WARRANTY PERIOD(X)	AGREED	NIL
		MINIMUM QUOTED GUARANTEE/ WARRANTY PERIOD(Y)	NOT AGREED FOR STIPULATED BUT AGREED FOR DESIRED GUARANTEE/WARRANTY(Y)	LOADING @ 10 % OF THE ORDER VALUE PER ANNUM FOR THE REDUCED GUARANTEE PERIOD (X-Y)

BHEL R&D

Terms & Conditions of Reverse Auction

Against this enquiry for the subject item/ system with detailed scope of supply as per enquiry specifications, BHEL may resort to "REVERSE AUCTION PROCEDURE" i.e., ON LINE BIDDING (THROUGH A SERVICE PROVIDER). The philosophy followed for reverse auction shall be English Reverse (No ties).

1. For the proposed reverse auction, technically and commercially acceptable bidders only shall be eligible to participate.
2. Those bidders who have given their acceptance for Reverse Auction (quoted against this tender enquiry) will have to necessarily submit „online sealed bid? in the Reverse Auction. Non-submission of „online sealed bid? by the bidder for any of the eligible items for which techno-commercially qualified, will be considered as tampering of the tender process and will invite action by BHEL as per extant guidelines in vogue.
3. BHEL will engage the services of a service provider who will provide all necessary training and assistance before commencement of on line bidding on internet.
4. In case of reverse auction, BHEL will inform the bidders the details of Service Provider to enable them to contact & get trained.
5. Business rules like event date, time, bid decrement, extension etc. also will be communicated through service provider for compliance.
6. Bidders have to fax the Compliance form (annexure IV) before start of Reverse auction. Without this, the bidder will not be eligible to participate in the event.
7. In line with the NIT terms, BHEL will provide the calculation sheet (e.g., EXCEL sheet) which will help to arrive at "Total Cost to BHEL" like Packing & forwarding charges, Taxes and Duties, Freight charges, Insurance, Service Tax for Services and loading factors (for non-compliance to BHEL standard Commercial terms & conditions) for each of the bidder to enable them to fill-in the price and keep it ready for keying in during the Auction.
8. Reverse auction will be conducted on scheduled date & time.
9. At the end of Reverse Auction event, the lowest bidder value will be known on auction portal.
10. The lowest bidder has to fax/e-mail the duly signed and filled-in prescribed format for price breakup including that of line items, if required, (Annexure VII) as provided on case-to-case basis to Service provider within two working days of Auction without fail.
11. In case BHEL decides not to go for Reverse Auction procedure for this tender enquiry, the Price bids and price impacts, if any, already submitted and available with BHEL shall be opened as per BHEL's standard practice.
12. Bidders shall be required to read the "Terms and Conditions" section of the auctions site of Service provider, using the Login IDs and passwords given to them by the service provider before reverse auction event. Bidders should acquaint themselves of the „Business Rules of Reverse Auction?, which will be communicated before the Reverse Auction.
13. If the Bidder or any of his representatives are found to be involved in Price manipulation/ cartel formation of any kind, directly or indirectly by communicating with other bidders, action as per extant BHEL guidelines, shall be initiated by BHEL and the results of the RA scrapped/ aborted.
14. The Bidder shall not divulge either his Bids or any other exclusive details of BHEL to any other party.
15. In case BHEL decides to go for reverse auction, the H1 bidder (whose quote is highest in online sealed bid) may not be allowed to participate in further RA process.

AUTHORISATION LETTER FOR E-PAYMENT/ NEFT / RTGS
(PLEASE FILL UP THE FORM COMPLETELY IN CAPITAL LETTERS ON YOUR COMPANY LETTERHEAD ONLY)

Vendor Code (to be filled by BHEL)	
------------------------------------	--

Type of Request (Tick one)	NEW	CHANGE
1 Company Name		
2 Address		
3 City with PIN Code		
4 State		
5 PAN Number		
6 TIN/ VAT No.		
7 CST No.		
8 Service Tax No.		
9 Name of Contact Person		
10 Mobile number		
11 Ph. no. with STD Code		
12 Fax No. with STD Code		
13 Email ID		
14 Website (URL)		

BANK DETAILS FOR EFT / RTGS

1	Bank Name	
2	Branch	
3	Branch Code	
4	Branch Address	
5	Branch Phone No	
6	Account No.	
7	Account Type: SB/ Current/ other (Specify)	
8	MICR Code	
9	IFSC Code	

I, as an authorized representative / owner of the above named company, hereby state as under:

1. Enclosed here with a cancelled cheque in support of our company's bank details.
2. Authorize BHEL R&D Hyderabad, to electronically make payments to the designated bank account with bank charges, if any, to our account.
3. If the transaction is delayed or not effected at all for reasons of incomplete or incorrect information, I would not hold BHEL / transferring Bank responsible.
4. I hereby certify that the particulars given above are true, complete and correct.
5. This authority remains in full force until BHEL receives and acknowledge written notification requesting change or cancellation.

Date :
Company
Seal

Authorised Signatory
Designation :



RD:MPX:F-13

Bharat Heavy Electricals Limited

Corporate Research and Development Division
Vikasnagar, HYDERABAD- 500 093 (INDIA)

Ph: 040 - 23772704, Fax: 040 - 23770698, email: mpx@bhelrnd.co.in

VENDOR REGISTRATION FORM

(Indigenous supplier)

[FORM TO BE SUBMITTED* BY THE BIDDER ALONG WITH TECHNICAL-BID]

Before filling, please refer to instructions on page-4

1.0 VENDOR PROFILE:

1.1 Name and address of the vendor:

Phone Nos.:

Fax No.:

Email: 1. _____ 2. _____

1.2 Local representative name & address in Hyderabad/Secundrabad :

Phone Nos.:

Fax No.:

Email:

Contact Person:

Mobile No:

2.0 TYPE OF ORGANISATION:

PROPRIETORSHIP	Company:	Sister Concern (mention vendor registration number of main organization)	
Partnership	CORPORATION	Small Scale Industry	ANY OTHER(Please specify)

In case of SSI unit, copy of registration to be enclosed. It is requested that MSME registration certificate to be enclosed

3.0 ANNUAL TURN OVER:

#	Year	Turn-Over, Rs.
1	Current Year(budgeted)	
2	Previous year (200 - 0)	
3	Prior Year (200 - 0)	

4.0 NAME AND ADDRESS OF THE BANKER:

4.1 Bank Name

4.2 Branch name

4.3 Account number

4.4 Account Type

4.5 MICR Code:

4.6 IFSC Code(RTGS/NEFT):

4.7 Bank Phone number(s),

Blank cheque, duly cancelled, to be enclosed.

Please note that all payments shall be made through Electronic clearance services to your above account against the orders executed, if any.

5.0 REGISTRATION PARTICULARS(relevant copies to be enclosed)

5.1 IT Permanent Account No.(PAN):

5.2 State Sales Tax/VAT Registration No:

5.3 Central Sales Tax Registration No:

5.4 ED Registration No:

5.5 Service Tax Registration No:

5.6 PF Account No:

5.7 Labour Licence No:

5.8 ESI Account No:

6.0 CONTACT PERSON: S/Sri:

Designation:

Phone / Mobile No:

7.0 TOTAL NUMBER OF EMPLOYEES:

Graduates (Engr/Scientists/Mgmt/Fin.)	Consultants	Workers		
		Sup./Skilled	Semiskilled	Unskilled

8.0 LIST OF PRODUCTS/ SERVICES OFFERED:

#	Products/ Services	Capacity
1		
2		
3		
4		
5		
6		

9.0 REFERENCE LIST :

(Only recognized public and private sector companies, attach if printed copy available)

#	Customer	Volume / Year
1		
2		
3		
4		
5		
6		
7		

10.0 INFRASTRUCTURE / FACILITIES:

#	Facility (with specifications)	Age/ Year procured

1		
2		
3		
4		
5		
6		
7		
8		
9		
10		

11.0 REGISTRATION WITH OTHER BHEL UNIT/UNITS:

#	Unit	Registration No	Year
1			
2			
3			
4			

12.0 ANY OTHER INFORMATION :**DECLARATION:**

The information furnished above is true and authentic.

(CEO / PROPRIETOR)

SEAL:

DATE:

Note:

1. Registered bidders, having BHEL (R&D) registration no. or have submitted this format for registration, need not furnish this information again.
2. The competent authority reserves the right to accept or reject the registration.
3. Vendors approved for registration will be informed by mail / email, as convenient. A separate communication will be sent in case of non-registration also, citing reasons thereof.
4. BHEL reserves the right to take penal action as deemed fit if any of the information provided by the vendor(s) is found to be incorrect.
5. AGM, Head (MM) may be contacted for clarification/additional information on registration.

Instructions

1. Fill all items. Please mention "N.A." for items/ clauses not applicable.
2. Use A4 sheets for this document and the enclosures. Use of additional sheets is permitted if space provided is not adequate.
3. Attach copies of latest documents in respect of items 5.0 (Registration no.s)
4. Photographs of registered office and the chief executive/proprietor shall be furnished.



RD:MPX:F-14

Bharat Heavy Electricals Limited

Corp. R&D DIVISION

VIKAS NAGAR,

HYDERABAD- 500 093 (INDIA)

SUPPLIER REGISTRATION FORM

(FOREIGN SUPPLIER)

ALL COLUMNS SHOULD BE PROPERLY FILLED IN THE SPACE PROVIDED FOR. WHEREVER IT IS NOT APPLICABLE PLEASE WRITE "NOT APPLICABLE". INCOMPLETE OR INCORRECT FORMS MAY NOT BE CONSIDERED.

1.0 GENERAL INFORMATION:

1.1 NAME OF COMPANY

1.2 DETAILS OF HEAD OFFICE:

ADDRESS :
TELEPHONE :
FAX :
EMAIL :
WEB SITE :

1.3 DETAILS OF FACTORY/WORKS:

ADDRESS :
TELEPHONE :
FAX :
EMAIL :
WEB SITE :

1.4 DETAILS OF MARKETING AGENT

ADDRESS :
TELEPHONE :
FAX :
EMAIL :
WEB SITE :

1.5 CHIEF EXECUTIVE

1.6 CONTACT PERSON(S)
FOR PRODUCT OFFERED

NAME(S) :
OFFICIAL CPACITY :
ADDRESS :
TELEPHONE :
FAX :
EMAIL :

1.7 YEAR OF ESTABLISHMENT

1.8 PRODUCTION CAPACITY PER ANNUM

1.9 PARTICULARS OF PRODUCT INCLUDING
SPECIFICATION AND RANGE OFFERED
FOR REGISTRTION
(Attach brouchers and catalogues)

1.10 NAME(S) OF BANKERS

1.11 BANKER'S CERTIFICATE

1.12 PORT OF LOADING

1.13 NEAREST AIRPORT

1.14 NAME OF THE INDIAN AGENT, IF ANY
WITH AUTHORIZATION LETTER

2.0 FINANCIAL INFORMATION:

2.1 TOTAL CAPACITY

2.2 ANNUAL TURN OVER FOR LAST 3 YEARS

2.3 WHEHER CREDIT LICENSE ACCEPTABLE YES/NO

3.0 QUALITY MANAGEMENT SYSTEMS

ENCLOSED FORMAT PART-B

3.1 EXPERIENCE LIST FOR SAME/ SIMILAR ITEMS
TO BE ENCLOSED

4.0 FUTURE EXPANSION PLANS:

(Give details)

5.0 LIST OF ENCLOSURES:

(Including brouchers, catalogues, technical literature etc)

6.0 ANY OTHER INFORMATION:

SIGNATURE OF SUPPIER (Authorized signatory)

NAME :

DESIGNATION :

DATE :

OFFICIAL SEAL

Note:

1. BHEL Reserves the right to take penal action as deemed fit if any of the information provided by the vendor is found to be incorrect.
2. Please attach separate sheets, if space found is inadequate



RD:MPX:F-13

Bharat Heavy Electricals Limited

Corp. R&D DIVISION

VIKAS NAGAR,

HYDERABAD- 500 093 (INDIA)

Ph: 040 – 23772704, Fax: 040 – 23770698, email: mpx@bhelrnd.co.in

GUIDE LINES REGARDING DEALINGS WITH INDIAN AGENTS OF FOREIGN SUPPLIERS

- i. BHEL shall deal directly with foreign vendors, wherever required, for procurement of goods. However, if the foreign principal desires to avail of the services of an Indian agent, then the foreign principal should ensure compliance to regulatory guidelines - which require mandatory submission of an Agency Agreement.
- ii. It shall be incumbent on the Indian agent and the foreign principal to adhere to the relevant guidelines of Government of India, issued from time to time.
- iii. The Agency Agreement should specify the precise relationship between the foreign OEM / foreign principal and their Indian agent and their mutual interest in the business. All services to be rendered by agent/ associate, whether of general nature or in relation to the particular contract, must be clearly stated by the foreign supplier/ Indian agent. Any payment, which the agent or associate receives in India or abroad from the OEM, whether as commission or as a general retainer fee should be brought on record in the Agreement and be made explicit in order to ensure compliance to laws of the country.
- iv. Any agency commission to be paid by BHEL to the Indian agent shall be in Indian currency only.
- v. Whenever Indian agents are representing on behalf of their principals the relevant authorisation letter and agreement copy to be enclosed along with Technical bid to consider the offer.

 Corp. R&D	PURCHASE SPECIFICATION GROUP : DNA/BHEL CORP R&D	SAG-535-48-11
		REV NO: 00
		PAGE : 1 OF 8

COPYRIGHT AND CONFIDENTIAL
The information on this document is the property of Bharat Heavy Electricals Limited.

Technical specification for manufacturing, supply, assembly and erection of floating pontoons, mooring system and solar panel supporting structures

 बीएच ई एल BHEL Corp. R&D	PURCHASE SPECIFICATION GROUP : DNA/BHEL CORP R&D	SAG-535-48-11
		REV NO: 00
		PAGE : 2 OF 8

1.0 Scope of Supply

Manufacturing, supply, assembly and erection of the following items as per technical specifications given in clause 2.0

1.1 Floating pontoons made of HDPE

1.2 Connecting pins and accessories for pontoon assembly.

1.3 Hand railing made of Stainless steel with accessories.

1.4 Stainless Steel (SS 304) chain for hand rails

1.5 Solar panel supporting structures with all accessories for connecting with pontoons

1.6 Mooring system for the floating assembly.

1.7 Assembly of floating pontoons and supporting structure's as per the lay out.

2.0 Technical Specification

SI no.	Feature	Specification/requirement	Quantity
1	HDPE Floating pontoons	<ul style="list-style-type: none"> • Size of the pontoon (length x width x height) is 500 mm x 500 mm x 400 mm • Material of the pontoon shall be HDPE • Thickness of the pontoon lug shall be of minimum 22 mm • Side wall thickness of the pontoon shall be minimum 5 mm or higher • Bottom wall thickness of the pontoon shall be minimum 5 mm or higher • Top wall thickness of the pontoon shall be minimum 8 mm or higher • Weight of the pontoon shall be 7 Kg \pm 10% • Pontoon top wall design shall be of anti-skid surface • Pontoon shall be nontoxic, resistant to frost & chemical corrosion • Load carrying capacity (Buoyancy) of the pontoon 	560 No and as per layout – drawing no SAG-535-48-08 and SAG-535-48-09



PURCHASE SPECIFICATION
GROUP : DNA/BHEL CORP R&D

SAG-535-48-11

REV NO: 00

PAGE : 3 OF 8

		<p>shall be 350 Kg/m² or higher</p> <ul style="list-style-type: none"> Density shall be 0.954 gm./cc±5% Tensile strength at yield shall be 27.0 MPa or higher Impact strength of pontoon shall be 150 KJ/m² or higher Melt flow index shall be 0.89 grams/ 10 Minutes @ 190 Degree C/ 10 Kg. Load Color of the pontoon shall be Blue# <p># <u>Color of the pontoon is tentative, Vendors are requested to suggest color scheme of Pins and pontoons for better aesthetics. Vendor has to take the M/s BHEL approval for color before manufacturing of the pontoons.</u></p>	
2	Fixing pins and other accessories for assembling pontoons	<p>The accessories shall include internal connecting pin, external lug connector, sliding nut, spacer, cushions and any other accessories required.</p> <p>Material of the accessories shall be HDPE (same as floating pontoon)</p>	As required for the assembly of pontoons as per attached Layout drg:SAG-535-48-009
3	Hand rails and Accessories for fixing with pontoons	<p>Material of the hand rails and accessories shall be SS 304</p> <p>Height of the hand rail shall be 0.75 mts</p> <p>Diameter of the hand rail shall be 50 mm and the thickness shall be 1.6 mm or higher</p> <p>Spacing of handrails shall be 1.5 mts</p> <p>Hand rails shall include fixing/ fastening the same with pontoons</p> <p>Hand rail shall have provision for holding the chain in two rows</p> <p>Hand rails are required all around the floating platform</p>	As required for the complete outer periphery of the assembly as shown in the lay out drg:SAG-535-48-009



PURCHASE SPECIFICATION
GROUP : DNA/BHEL CORP R&D

SAG-535-48-11
REV NO: 00
PAGE : 4 OF 8

		on outer periphery and on the both sides of the walkway	
4	Stainless steel chain for hand rails	Two rows of SS 304 chain with wire diameter of 6 mm or higher shall be provided for the hand rails	400 mts (for two rows 2x200 mts)
5	Mooring system	<p>600x600x600 mm concrete block with proper connecting arrangements and chain for the mooring system.</p> <p>The mooring links shall be Gr. 80 hot dipped galvanized steel chain. The galvanization shall be minimum 100 microns or higher. The chain link wire/rod diameter shall be minimum 10 mm or higher</p> <p>The length of the chain shall be able to match maximum water depth of 4 mts (tentative) and it's sagging as per the attached Drawing No SAG-535-48-10. The actual water depth shall be measured by the vendor during erection and has to adjust the Mooring system.</p> <p><u>Detailed mooring system connections and required components shall be provided along with the technical bid</u></p>	8 Nos
6	Solar panel Supporting structures	<p>As per the attached drawing No: SAG-535-48-08</p> <p>Material shall be of Stainless steel (SS304)</p> <p>All the fasteners (bolts, nuts, washers and bushes) shall be of SS 304 or SS 316</p> <p>Vendor shall submit the connection details between pontoon lug and supporting structure along with the technical bid.</p> <p><u>Note: Any improvement on the structures in terms of design / material can be done by suppliers subjected to the approval of M/s BHEL During technical bid evaluation</u></p> <p><u>Any improvement on the structure by supplier has to qualify the structural design as per IS 800 and the wind speed to be considered as 44 m/s.as per IS 875.Vendor shall submit the detailed analysis report for the improved</u></p>	32 Nos required for the assembly as shown in the Drg No: SAG-535-48-008. And Drg No:SAG-535-48-009



PURCHASE SPECIFICATION
GROUP : DNA/BHEL CORP R&D

SAG-535-48-11

REV NO: 00

PAGE : 5 OF 8

		<p><u>structure along with the technical bid.</u></p> <p><u>In absence of detailed structural analysis report any change in design will not be entertained and vendor has to follow the BHEL design.</u></p> <p><u>Each supporting structure shall carry 3 solar panels as per attached drawing SAG-535-48-08. Each solar panel weighs 25 Kg. The total 96 no of panels are to be mounted on 32 supporting structures.</u></p>	
7	Supporting structures for walk way on both sides of the floating platform	<p>The supporting structure for walkway with additional stiffeners, Marine grade aluminium chequered plate having thickness 6 mm or higher shall be provided for the walkway as per attached drawings SAG-535-48-08</p> <p>The length of the walkway shall be as per attached layout drawing no: SAG-535-48-09</p> <p>The walk way shall be aligned with the top surface of the floating pontoon and necessary details for the same shall be <u>submitted along with technical bid.</u></p>	8 No's
8	Synthetic Life jackets	<p>Shall be confirming to IS 6685: 2009 or equivalent</p> <p>Shall have High - Visibility Orange Colour fabric cover.</p> <p>Shall have Adjustable Buckle for tightening and specially designed with Velcro fitment for easy / quick donning in an emergency</p> <p>Special Construction of the jacket shall allow the wearer quick turning in case of being knocked unconscious in water.</p> <p>Shall be Chemically resistant to sea water and petroleum products</p> <p>Retro - reflective Tape Solas Approved</p> <p>Inner Foam : Soft Polyethylene</p> <p>Size : 68 X 37 X 10 cms</p>	8 No



PURCHASE SPECIFICATION
GROUP : DNA/BHEL CORP R&D

SAG-535-48-11

REV NO: 00

PAGE : 6 OF 8

		<p>Floatability : 16.5 Kg or higher</p> <p>Accessory : Whistle</p> <p>Shelf life : 5 years</p> <p>Colour: Orange.</p> <p>Approvals: Life jacket should be IRS approved and stamped, confirming to SOLAS 74 with latest amendments</p>	
9	Installation and commissioning at site	<p>Vendor shall assemble and install all the pontoons and structures as per the attached drawing SAG-535-48-09.</p> <p>Mooring system shall be installed at the desired location after positioning the floating platform.</p> <p>Vendor has to supply Stainless steel or Aluminium bolts, nuts and washers to connect the solar panel to the supporting structures.</p> <p>The tentative site is Hussainsagar, Near Sanjeevaiah Park, Hyderabad, Actual site will be in and around Hyderabad like Gandipet lake/ Saroornagar lake based on availability and will be confirmed before commencement of delivery</p> <p>The shifting of all the materials to the assembly and erection point from storage location (BHEL R&D, Vikas Nagar) for erection will be in the scope of the vendor and he has to make necessary arrangements for the same</p> <p>Note: <u>The walk way arrangement shown in the drawing SAG-535-48-08 and SAG-535-48-09 is tentative. This may change during execution of the project.</u></p>	Floating platform along with walkway and structures.
10	Warranty (On-site)	As per Clause 5.0	See Clause 5.0
11	Safety during the erection and commissioning	The contractor shall take all the necessary measures to prevent accidents. It is the responsibility of the contractor not to allow any worker to work in an unsafe condition, nor with unsafe equipment.	

 बीएच ई एल BHEL Corp. R&D	PURCHASE SPECIFICATION GROUP : DNA/BHEL CORP R&D	SAG-535-48-11
		REV NO: 00
		PAGE : 7 OF 8

		The contractor shall provide adequate and suitable Personal Protective Equipment's (PPEs), wherever they are required, to all concerned personnel. The quality of this equipment's shall conform to National (BIS) or International Standards.	
12	Miscellaneous Items	Miscellaneous Items like fixtures, spanners and any other items required for successful completion of the project	As required for the work

3.0 Vendor Qualification Criteria

The vendors must have the following to be eligible for offering floating pontoons and structures against this tender and shall comply for the same. The vendors not meeting following criteria will not be considered during technical evaluation.

- 3.1 Vendor shall submit complete testing procedure for material identification, flow index, load carrying capacity and tensile strength for the floating pontoons and accessories before taking up the manufacturing.
- 3.2 Vendor shall submit the material test certificates for the structural components along with the shipment.
- 3.3 Vendor shall submit the test results for the HDPE pontoons tested at CIPET or Govt. certified laboratories along with shipment.

4.0 Testing Procedures and standards:

- 4.1 Vendor shall submit the material test certificates for the structural components along with the shipment.
- 4.2 Vendor shall submit the following test results for the HDPE pontoons tested at CIPET or GOVT certified laboratories along with shipment
 - 4.2.1 HDPE material identification as per CIPET standard practice
 - 4.2.2 Melt flow index of the HDPE Pontoon as per ASTM D-1238
 - 4.2.3 Tensile test as per ASTM D 638
 - 4.2.4 Impact strength test as per ASTM D256

	PURCHASE SPECIFICATION GROUP : DNA/BHEL CORP R&D	SAG-535-48-11
		REV NO: 00
		PAGE : 8 OF 8

5.0 Warranty:

- Vendor has to provide the on-site warranty (labour, parts) for a period of minimum 48 Months from the date of successful commissioning for pontoons and accessories (Sl. No 1 and 2 of clause 2.0 of this document).
- Vendor has to provide the on-site warranty (labour, parts) for a period of minimum 24 Months from the date of successful commissioning for structures (Sl. no:3 to 7 of clause 2.0 of this document).
- Vendor shall attend the fault within 48 hours from the reporting time. Vendor shall furnish the report by giving details of fault, action taken and steps to prevent occurrence.
- Vendor has to supply necessary spares including consumables required if any for continuous operation/working of the Equipment/supply for the warranty period after the successful commissioning.
- Warranty certificates shall be submitted for all bought-out items along with the shipment.

6.0 List of enclosures:

1. Solar panel supporting structure drawing and overall Lay out Drg No: SAG-535-48-08
2. Floating solar platform Detailed lay out Drawing No: SAG-535-48-09
3. Mooring system drawing - Drg No: SAG-535-48-10
4. Technical comparison sheet- Doc No: SAG-535-48-12
5. Price-Bid format-Doc No: SAG-535-48-13

---00---

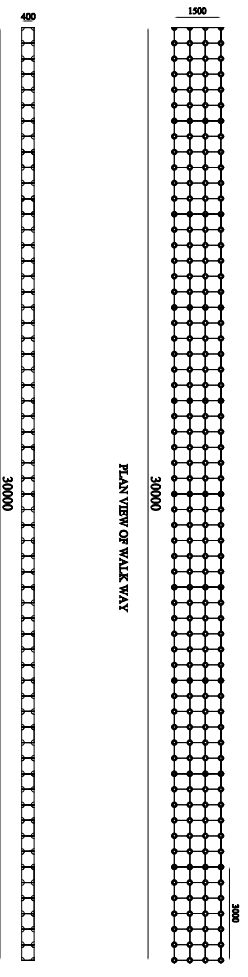
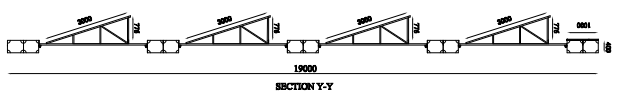
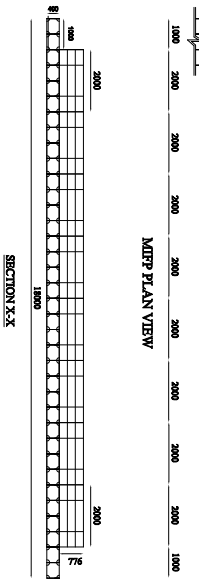
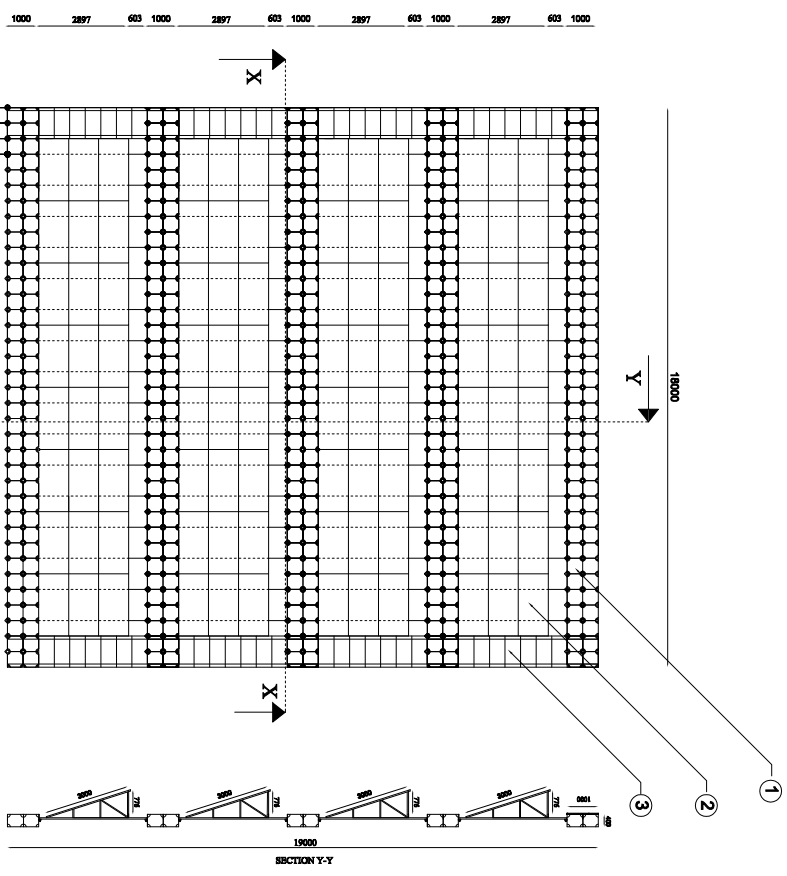

SECTION VIEW OF WALK WAY

NOTE:

- ① — HDPE PONTOON (500 X 500 X 400 mm)
- ② — SOLAR PANEL (1975 X 995 mm)
- ③ — STAINLESS STEEL FRAME AND MARINE GRADE ALUMINIUM CHEQUERED PLATE
- ④ — WALK WAY

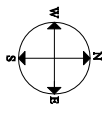

REV	DATE	BY	CHKD	REASON
01	15/08/2024	SHAHAT	SHAHAT	ISSUED FOR TENDER
02	15/08/2024	SHAHAT	SHAHAT	REVISED DRAWING

TYPE OF PRODUCT	OR MAKE OF	CUSTOMER/PROJECT
SHAHAT HEAVY ELECTRODIALS LTD.	SHAHAT HEAVY ELECTRODIALS LTD.	SHAHAT HEAVY ELECTRODIALS LTD.
PROJECT NO.	REV.	DATE
15/08/2024	01	15/08/2024
SCALE	DATE	SCALE
1:1	15/08/2024	1:1
PROJECT NO.	REV.	DATE
15/08/2024	01	15/08/2024

PROJECT: FLOATING SOLAR PLATFORM | DRAWING NO: SAG-535-48-09

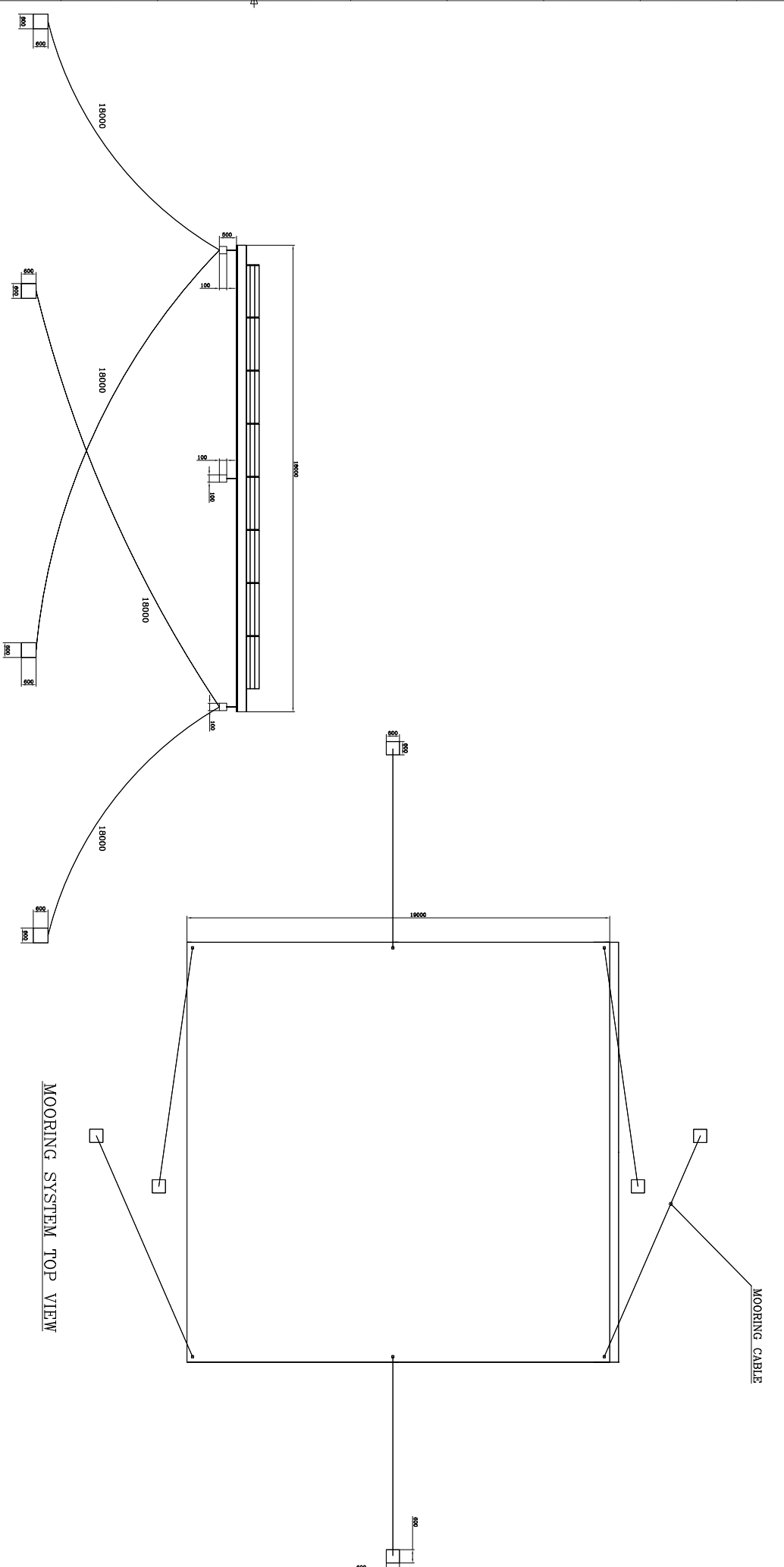

MOORING SYSTEM SECTIONAL VIEW

MOORING SYSTEM TOP VIEW

REV	DATE	BY	CHKD	DESCRIPTION
01	15/03/2024
02	15/03/2024
03	15/03/2024
04	15/03/2024
05	15/03/2024
06	15/03/2024
07	15/03/2024
08	15/03/2024
09	15/03/2024
10	15/03/2024
11	15/03/2024
12	15/03/2024
13	15/03/2024
14	15/03/2024
15	15/03/2024

TYPE OF PRODUCT
OR NAME OF CUSTOMER/PROJECT

SHIVHATI HEAVY ELECTRICALS LTD.
SHELVING & RACKS
INDUSTRIAL & COMMERCIAL

MOORING SYSTEM

MOORING SYSTEM

DATE: 15/03/2024

SCALE: 1:1

PROJECT NO: SAG-535-48-10

DATE: 15/03/2024

SCALE: 1:1

PROJECT NO: SAG-535-48-10

A B C D E F G H I J K L M

1 2 3 4 5 6 7 8 9 10 11 12 13 14 15 16

Technical Compilation sheet				
		Doc No: SAG-535-48-12		
Sl.No.	Item description	BHEL Specification	Vendor acceptance	Remarks
1.0	HDPE Floating pontoons			
1.01		Size of the pontoon (l x bxh) is 500 mm x 500 mm x 400 mm		
1.02		Material of the pontoon shall be HDPE		
1.03		Thickness of the Pontoon lug shall be of minimum 22 mm		
1.04		Side wall thickness of the pontoon shall be minimum 5 mm or higher		
1.05		Top wall thickness of the pontoon shall be minimum 8 mm or higher		
1.06		Bottom wall thickness of the pontoon shall be minimum 5 mm or higher		
1.07		Weight of the pontoon shall be 7 Kg ± 10%		
1.08		Pontoon top wall design shall be of anti-skid surface		
1.09		Pontoon shall be nontoxic, resistant to frost & chemical corrosion		
1.10		Load carrying capacity (Buoyancy) of the pontoon shall be 350 Kg/m ² or higher		
1.11		Density shall be 0.954 gm./cc±5%		
1.12		Tensile strength at yield shall be 27.0 MPa or higher		
1.13		Impact strength of pontoon shall be 150 KJ/m ² or higher		
1.14		Melt flow index shall be 0.89 grams/ 10 Minutes @ 190 Degree C/ 10 Kg. Load		
1.15		Color of the pontoon shall be Blue Color of the pontoon is tentative, Vendors are requested to suggest color scheme of Pins and pontoons for better aesthetics. Vendor has to take the M/s BHEL approval for color before manufacturing of the pontoons.	Note:	
2.0	Fixing pins and other accessories for assembling for the pontoons			
2.01		The accessories shall include Internal connecting pin, external lug connector, sliding nut, spacer, cushions and any other accessories required.		
2.02		Material of the accessories shall be HDPE (same as floating pontoon)		
3.0	Hand rails and Accessories for fixing with pontoons			
3.01		Material of the hand rails and accessories shall be SS 304		
3.02		Height of the hand rail shall be 0.75 mts		
3.03		Diameter of the hand rail shall be 50 mm and the thickness shall be 1.6 mm or higher		
3.04		Spacing of handrails shall be 1.5 mts		
3.05		Hand rails shall include the fixing/ fastening the same to pontoons		
3.06		Hand rail shall have provision for holding the chain in two rows		
3.07		Hand rails are required all around the floating platform on outer periphery and on the both sides of the walkway		
4.0	Stainless steel chain for hand rails			
4.01		Two rows of SS 304 chain with wire diameter of 6 mm or higher shall be provided for the hand rails		
5.0	Mooring system			
5.01		600x600x600 mm concrete block with proper connecting arrangements and steel rope/chain for the mooring system.		
5.02		The mooring links shall be Gr. 80 hot dipped galvanized steel chain. The galvanization shall be minimum 100 microns or higher. The chain link wire/rod diameter shall be minimum 10 mm or higher		
5.03		The length of the chain shall be able to match max water depth of 4 mts (tentative) and it's sagging as per the attached Drawing No SAG-535-48-10. The actual water depth shall be measured by vendor during erection and has to adjust the Mooring system.		
5.04		Detailed mooring system connections and required components shall be provided along with the technical bid		

6.0	Solar panel Support structures			
6.01		As per the attached drawing No: SAG-535-48-08		
6.02		Material shall be of Stainless steel (SS304)		
6.03		All the fasteners (bolts, nuts, washers and bushes) shall be of SS 304 or SS 316		
6.04		Vendor shall submit the connection details between pontoon lug and support structure along with technical bid.		
6.05		Note: Any improvement on the structures in terms of design / material can be done by suppliers subjected to the approval of M/s BHEL During technical bid evaluation Any improvement on the structure by supplier has to qualify the structural design as per IS 800 and the wind speed to be considered as 44 m/s.as per IS 875.Vendor shall submit the detailed analysis report for the improved structure along with the technical bid. In absence of detailed structural analysis report any change in design will not be entertained and vendor has to follow the BHEL design as it is. Each support structure shall carry 3 solar panels as per attached drawing SAG-535-48-08. Each solar panel weighs 25 Kg. The total 96 no of panels are to be mounted on 32 support structures.		
7.0	Support structures for walk way on both sides of the floating platform			
7.01		The support structure for walkway with additional stiffeners, Marine grade aluminium chequered plate having thickness 6 mm or higher shall be provided for the walkway as per attached drawings SAG-535-48-08		
7.02		The length of the structural walkway shall be as per attached layout drawing no: SAG-535-48-09		
7.03		The walk way shall be aligned with the top surface of the floating pontoon and necessary details for the same shall be submitted along with technical bid.		
8.0	Synthetic Life jackets			
8.01		Shall be confirming to IS 6685: 2009 or equivalent		
8.02		Shall have High – Visibility Orange Colour fabric cover.		
8.03		Shall have Adjustable Buckle for tightening and specially designed with Velcro fitment for easy / quick donning in an emergency		
8.04		Special Construction of the jacket shall allow the wearer quick turning in case of being knocked unconscious in water.		
8.05		Shall be Chemically resistant to sea water and petroleum products		
8.06		Retro – reflective Tape Solas Approved		
8.07		Inner Foam : Soft Polyethylene		
8.08		Size : 68 X 37 X 10 cms		
8.09		Floatability : 16.5 Kg or higher		
8.1		Accessory : Whistle		
8.11		Shelf life : 5 years		
8.12		Colour: Orange.		
8.13		Approvals: Life jacket should be IRS approved and stamped, confirming to SOLAS 74 with latest amendments		
9.0	Installation and commissioning at site	Tentative site is Husaainsagar lake and may be changed to other lake like gandipet lake/sarooranagar lake in and around Hyderabad		
9.01		Vendor shall assemble and install all the pontoons and structures as per the attached drg:SAG-535-48-09		
9.02		Mooring system shall be installed at the desired location after positioning the floating platform.		
9.03		Vendor has to supply SS/AL bolt, nut and washers to connect the solar panel to the support structures.		
9.04		The shifting of all the materials to the assembly and erection point from storage location (BHEL R&D, Vikas Nagar) for erection will be in the scope of the vendor and he has to make necessary arrangements for the same		
9.05		Note: The walk way arrangement shown in the drawing SAG-535-48-08 and SAG-535-48-09 is tentative. This may change during execution of the project.		

10.0	Warranty (On-site)			
10.01		As per Clause 5.0 of specificaton SAG-535-48-11		
11.0	Safety during the erection and commissioning			
11.01		The contractor shall take all the necessary measures to prevent accidents. It is the responsibility of the contractor not to allow any worker to work in an unsafe condition, nor with unsafe equipment.		
11.02		The contractor shall provide adequate and suitable Personal Protective Equipment's (PPEs), wherever they are required, to all concerned personnel. The quality of this equipment's shall conform to National (BIS) or International Standards.		
12.0				
12.01	Miscellaneous items	Vendor shall provide any other items required for the successful completion of the project like fixtures,tools, spares, handling equipment..etc.		
13.0	Test results			
12.01		HDPE material identification		
12.02		Melt flow indes for the HDPE pontoon as per ASTM-D-1238		
12.03		Tensile test as per ASTM D 638		
12.04		Impact test as per ASTM D 256		

Price Bid format								
Sl.No.	Item description	Doc No:SAG-535-48-13	Specification	Quantity (Q)	unit	Unit price (R)	Tax in % (T)	Total price including tax (Q*R)+(Q*R*T/100)
1	HDPE Floating pontoons	As per specification SAG-535-48-11		560	No			
2	Fixing pins and other accessories for assembling of the pontoons	As per specification SAG-535-48-11		*	No			
3	Hand rails and Accessories for fixing with pontoons	As per specification SAG-535-48-11		*	No			
4	Stainless steel chain for hand rails	As per specification SAG-535-48-11		400	Mts			
5	Mooring system	As per specification SAG-535-48-11		8	No			
6	Solar panel Support structures	As per specification SAG-535-48-11		32	No			
7	Support structures for walk way on both sides of the floating platform	As per specification SAG-535-48-11		8	No			
8	Synthetic Life jackets	As per specification SAG-535-48-11		8	No			
9	Miscellaneous items	As per specification SAG-535-48-11		*	lumpsum			
10	Necessary spares for successful completion and working for warranty period	Vendor shall provide the required spares and quantities as per the Lay out drawings SAG-535-48-08 and SAG-535-48-09		*	lumpsum			
11	Transportation	For the entire scope of supply		1	lumpsum			
12	Installation and commissioning at site with 48 months of onsite warranty for the scope of supply	As per specification SAG-535-48-11		1	set			
Total Price								
* Quantity shall be worked out by the vendor as per the attached specification SAG-535-48-11 and lay out as shown in the attached drgs:SAG-535-48-08 , SAG-535-48-09 and SAG-535-48-10.								