



429-002/A

BHARAT HEAVY ELECTRICALS LIMITED

(A Government of India Undertaking)
 HIGH PRESSURE BOILER PLANT
 PURCHASE DEPARTMENT - FOSSIL BOILERS
 THIRUCHIRAPALLI - 620014
 TAMILNADU (INDIA)

PHONE :2577645
 GRAMS : BHARATELEC
 FAX NO: 2520719
 E-mail: srchandran@bheltry.co.in
 Web:

Page
1/7

	Enquiry No	Enquiry Date	Due Date for Quotation
	2681400039	16.12.2014	19.01.2015
Please quote Enquiry No, Date and due date in all correspondences. This is only a request for quotation and not an order			

Item	Description	Unit	Quantity	Delivery Quantity	Schedule Date
10	<p><H><U>SPECIFICATION FOR 250MM DCEM BRAKE PANEL:</></> THE PANEL SHOULD BE SUITABLE FOR SUPPLY DC TO 250 MM BCH BRAKE UNIT COIL:</p> <p>1.,,Input supply to the panel is 415V 50 HZ. 2.,,It will be converted to DC by a Silicon or Selenium diode bridge rectifier. 3.,,The bridge rectifier shall have two no's of 40HM 150 and two no's of 40HMR 150 or equivalent selenium rectifier with cooling sinks. 4.,,Rectifier, Two pole MCBs, Two no of BCH contactors (MC10DN22) and one no of BCH on delay timer KRTPN10K- 1 shall be used along with proper links, connector blocks,etc; in electrical circuit. 5.,,The panel shall have two compartments, separated by necessary sheets. 6.,,First compartment shall be for wire wound resistors and next shall be for circuit assembly mounted on a base plate. 7.,,The wire wound resistors value shall be of two sections. (32 ohms , 32 ohms-series connection) - First section and (80 ohms, 52 ohms, 42 ohms -series connection) shall be next section. All resistors shall be of 200W. All resistors shall be wound with best quality Ni/Cr or Ni/Cr Alloy Resistance Wire having very low temp.Co-efficient on highly alumina based porcelain pipes/rods and wire is protected with high temp. Resistance Compound. The highly plated tin copper wires shall be used for terminations, 8.,,The contactor shall be wired in such a way that initially first section of resistors shall be added in series with the brake coil and after a time interval both section of wires shall be in series. So that</p>	NO	4.000	4.00	30.03.15

The offers should reach us 30 minutes before the time of opening of tenders.
 The offers will be opened at 14.30 hrs on the due date of tender in the presence of tenderers who have submitted their offer and who may like to be present for the tender opening.Late and delayed offers are liable to be rejected.

Yours faithfully,
 For **BHARAT HEAVY ELECTRICALS LIMITED**

MANAGER / PURCHASE

FOSSIL BOILERS

Purchase M / MFG

BHEL, TRICHY - 620 014



BHARAT HEAVY ELECTRICALS LIMITED

(A Government of India Undertaking)
HIGH PRESSURE BOILER PLANT
PURCHASE DEPARTMENT - FOSSIL BOILERS
THIRUCHIRAPALLI - 620014
TAMILNADU (INDIA)

Page
2/7
PHONE :2577645
GRAMS : BHARATELEC
FAX NO: 2520719
E-mail: srchandran@bheltry.co.in
Web:

2681400039 / 16.12.2014

the initial DC voltage to brake coil shall be high, after less.

9.,,The brake panel sheet thickness shall be minimum 2MM.

10.,,In resistor compartment necessary holes shall be provided so that heat shall escape as well as no rain water shall enter inside.

11.,,One terminal blocks shall be in resistor compartment , necessary terminal blocks with spare shall be next compartment.

12.,,Total dimension of panel shall be of minimum 1000x600x400 (height x width x depth). CRC sheet and powder coat finish shall be done.Non corrosive paint shall be applied.

13.,,Input shall have a 4A double pole MCB.

14.,,Coil control voltage is 110V AC.

15.,,Suitable resin shall be applied on all wire wire wound resistors- so that heat conduction is good.

16.,,Suitable panel dimensional drawing, electrical items positioning diagram, panel wiring diagram shall be sent for approval before manufacturing.

17.,,All the panel wirings shall be of 2.5 sqmm Copper cables. Control and power cable shall be of different colour. 3 point lock shall be provided.

18.,,On top, inner surface of panel 250 MM BRAKE UNIT PANEL shall be inscribed in strip.

19.,,All the panel shall have a base channel for mounting, also all panels shall have necessary cable glands for cable entry.

20.,,FIFTEEN no's of BCH contactor MC10DN22 coil (110v)and FIFTEEN no's of BCH contactor MC10DN22 tips (moving, fixed arrangements ,etc) , Five no s of 32 ohms , Five no s of 42 ohms ,Five no s of 52 ohms resistors, Five no s of 80 ohms resistors ,Five no s of 112 ohms resistors, shall be supplied as spare. All resistors shall be of same dimension.

21.,,Two no of Manual operated hydraulic crimping machine - capacity : 6 ton with 9 sets of dies (6 sqmm , 10 sqmm ,16sqmm , 25sqmm , 35sqmm, 50sqmm, 70 sqmm, 95 sqmm, 120sqmm)-Klauke Make, three no of Fluke 317/319 Clamp Meters shall be supplied along with brake panel.

22.Model diagram is attached.

23.Inspection by BHEL person will be done at

The offers should reach us 30 minutes before the time of opening of tenders.
The offers will be opened at 14.30 hrs on the due date of tender in the presence of tenderers who have submitted their offer and who may like to be present for the tender opening.Late and delayed offers are liable to be rejected.

Yours faithfully,
For **BHARAT HEAVY ELECTRICALS LIMITED**

MANAGER / PURCHASE
(FOSSIL BOILERS)
Yours faithfully,
BHEL, TRICHY - 620 014.



BHARAT HEAVY ELECTRICALS LIMITED

(A Government of India Undertaking)
HIGH PRESSURE BOILER PLANT
PURCHASE DEPARTMENT - FOSSIL BOILERS
THIRUCHIRAPALLI - 620014
TAMILNADU (INDIA)

Page
3/7
PHONE :2577645
GRAMS : BHARATELEC
FAX NO: 2520719
E-mail: srchandran@bheltry.co.in
Web:

2681400039 / 16.12.2014

vendor works before
dispatch.

24. At the time of inspection test certificate for
panels, contactors,
resistors, diodes shall be submitted.

20 NO 12.000 12.00 30.03.15

<H><U>SPECIFICATION FOR 300 MM DCEM
BRAKE PANEL:</></>

THE PANEL SHOULD BE SUITABLE FOR
SUPPLY DC TO 300 MM BCH BRAKE UNIT
COIL:

1. Input supply to the panel is 415V 50 HZ.
2. It will be converted to DC by a Silicon or Selenium diode bridge rectifier.
3. The bridge rectifier shall have two no's of 40HM 150 and two no's of 40HMR 150 or equivalent selenium rectifier with cooling sinks.
4. Rectifier, Two pole MCBs, Two no of BCH contactors(MC10DN22) and one no of BCH on delay timer KRTPN10K- 1 shall be used along with proper links , connector blocks ,etc in electrical circuit.
5. The panel shall have two compartments, separated by necessary sheets.
6. First compartment shall be for wire wound resistors and next shall be for circuit assembly.
7. The wire wound resistors value shall be of two sections. (32 ohms, 32 ohms-series connection) - First section and (42 ohms, 42 ohms -series connection) shall be next section. All resistors shall be 200 W.
8. The contactor shall be wired in such a way that initially first section of resistors shall be added in series with the brake coil and after a time interval both section of wires shall be in series. So that the initial the DC voltage to brake coil shall be high, after less.
- 9.,,The brake panel sheet thickness shall be minimum 2 MM.
- 10.,,In resistor compartment necessary holes shall be provided so that heat shall escape as well as no rain water shall enter inside.
- 11.,,One terminal blocks shall be in resistor compartment, necessary terminal blocks with spare shall be next compartment,
- 12.,,Total dimension of panel shall be of minimum 1000 x 600 x 400 (height x width x depth).CRC sheet and powder coat finish shall be done. NO on corrosive paint shall be applied.

The offers should reach us 30 minutes before the time of opening of tenders.
The offers will be opened at 14.30 hrs on the due date of tender in the presence of tenderers who have submitted their offer and who may like to be present for the tender opening. Late and delayed offers are liable to be rejected.

Yours faithfully,
For **BHARAT HEAVY ELECTRICALS LIMITED**

MANAGER / PURCHASE
(FOSSIL BOILERS)
Yours faithfully,



BHARAT HEAVY ELECTRICALS LIMITED

(A Government of India Undertaking)
HIGH PRESSURE BOILER PLANT
PURCHASE DEPARTMENT - FOSSIL BOILERS
THIRUCHIRAPALLI - 620014
TAMILNADU (INDIA)

Page
4/7
PHONE :2577645
GRAMS : BHARATELEC
FAX NO: 2520719
E-mail: srchandran@bheltry.co.in
Web:

2681400039 / 16.12.2014

- 13.,,Input shall have a 6 A double pole MCB ,
- 14.,,Coil control voltage is 110 V AC.
- 15.,,Suitable resin shall be applied on all wire wire wound resistors- so that heat conduction is good.
- 16.,,Suitable panel dimensional drawing, electrical items positioning diagram, panel wiring diagram shall be sent for approval before manufacturing.
- 17.,,On top, inner surface of panel 300 MM BRAKE UNIT PANEL shall be inscribed in strip.
- 18.Model diagram is attached.
- 19.Inspection shall be done before dispatch.

30 NO 3.000 3.00 30.03.15

<H><U>SPECIFICATION FOR 400 MM DCEM BRAKE PANEL:</U></H>

THE PANEL SHOULD BE SUITABLE FOR SUPPLY DC TO 400 MM BCH BRAKE UNIT COIL:

1. Input supply to the panel is 415V 50 HZ.
2. It will be converted to DC by a Silicon or Selenium diode bridge rectifier.
3. The bridge rectifier shall have two no's of 40HM 150 and two no's of 40HMR 150 equivalent selenium rectifier with cooling sinks.
4. Rectifier, Two pole MCBs, BCH contactors (MC10DN22, MC10EN22) and one no of BCH on delay timer KRTPN10K- 1 shall be used along with proper links , connector blocks ,etc in electrical circuit.
5. The panel shall have two compartments, separated by necessary sheets.
6. First compartment shall be for wire wound resistors and next shall be for circuit assembly.
7. The wire wound resistors value shall be of two sections. (80ohms , 80 ohms-parallel connection) - First section and ((112 ohms, 112 ohms), (32 ohms ,32 ohms)-series connection) shall be next section. All resistors shall be 200W.
8. The contactor shall be wired in such a way that initially (MC10EN22) first section of resistors shall be added in series with the brake coil and after a time interval (MC10DN22) both section of wires shall be in series. So that the initial the DC voltage to brake coil shall be high, after less.
9. The brake panel sheet thickness shall be minimum 2MM.

The offers should reach us 30 minutes before the time of opening of tenders. The offers will be opened at 14.30 hrs on the due date of tender in the presence of tenderers who have submitted their offer and who may like to be present for the tender opening.Late and delayed offers are liable to be rejected.

Yours faithfully,
For **BHARAT HEAVY ELECTRICALS LIMITED**

MANAGER / PURCHASE
(FOSSIL BOILERS)
Yours faithfully,



BHARAT HEAVY ELECTRICALS LIMITED

(A Government of India Undertaking)
HIGH PRESSURE BOILER PLANT
PURCHASE DEPARTMENT - FOSSIL BOILERS
THIRUCHIRAPALLI - 620014
TAMILNADU (INDIA)

Page
5/7
PHONE :2577645
GRAMS : BHARATELEC
FAX NO: 2520719
E-mail: srchandran@bheltry.co.in
Web:

2681400039 / 16.12.2014

- 10.,,In resistor compartment necessary holes shall be provided so that heat shall escape as well as no rain water shall enter inside.
- 11.,,One terminal blocks shall be in resistor compartment , necessary terminal blocks with spare shall be next compartment.
- 12.,,Total dimension of panel shall be of minimum 1000x600x400 (height x width x depth).CRC sheet and powder coat finish shall be done.Non corrosive paint shall be applied.
- 13.,,Input shall have a 6A double pole MCB.
- 14.,,Coil control voltage is 110V AC.
- 15.,,Suitable resin shall be applied on all wire wire wound resistors- so that heat conduction is good.
- 16.,,Suitable panel dimensional drawing, electrical items positioning diagram, panel wiring diagram shall be sent for approval before manufacturing.
- 17.,,On top, inner surface of panel 400 MM BRAKE UNIT PANEL shall be inscribed in strip.
- 18.Model diagram is attached.
- 19.Inspection shall be done before dispatch.

General Note:

PRE- QUALIFICATION CRITERIA

The BIDDER / VENDOR has to compulsorily meet all the following requirements to get qualified for consideration of the technical offer for the panels. If the vendor does not qualify as per PRE- QUALIFICATION CRITERIA, the technical offer of such BIDDER(s) / VENDOR(s) offer will not be evaluated.

1. Only those vendors who have supplied similar electrical panels should quote.
- 2 Bidder should furnish reference list of customers, with full contact details to whom electrical panels have been supplied in the past. The vendor should also submit following details which are necessary for qualifying their offer.
 - a) Name and postal address of the customer or company where similar item supplied.
 - b) Name, designation, contact phone numbers and email address of the contact person of the customer.
 - c) Month and year of Supply-PO Copy.
 - d) Performance certificate of from the customer for the satisfactory performance .

Note

The offers should reach us 30 minutes before The time of opening of tenders. The offers will be opened at 14.30 hrs on the due date of tender in the presence of tenderers who have submitted their offer and who may like to be present for the tender opening.Late and delayed offers are liable to be rejected.

Yours faithfully,
For **BHARAT HEAVY ELECTRICALS LIMITED**

MANAGER / PURCHASE
(FOSSIL BOILERS)
Yours faithfully,



BHARAT HEAVY ELECTRICALS LIMITED

(A Government of India Undertaking)
HIGH PRESSURE BOILER PLANT
PURCHASE DEPARTMENT - FOSSIL BOILERS
THIRUCHIRAPALLI - 620014
TAMILNADU (INDIA)

Page
6/7
PHONE :2577645
GRAMS : BHARATELEC
FAX NO: 2520719
E-mail: srchandran@bheltry.co.in
Web:

2681400039 / 16.12.2014

1. Please submit your detailed offer in two part bid system i.e Part-I. Technical bid+ Checklist (Annexure-A) + unpriced bid with indicating taxes & duties (Annexure-B) in a sealed cover super scribing on the cover as "TECHNICAL & COMMERCIAL BID / PART-II" Part-II. Priced offer in another separate sealed cover super scribing on the cover as Part-II

Both the covers shall be duly super-scribed with tender reference and due date of opening. These covers shall be put in a single cover duly super-scribed with tender reference and due date of opening and addressed to us.

2. Point-to-point confirmation to BHEL's specification and commercial terms & conditions shall be provided Annexure-A. All the Annexures should be filled and submitted along with the technical bid (no row shall be left blank), else your offer is liable for rejection.

3. Offers with validity of less than 120 days and non-acceptance of LD , RP clause, PBG & Payment terms, will lead to rejection of submitted offer.

4. If the due date of tender opening happens to be a holiday, the tenders will be opened on the next working day.

5. All clarifications may be sought at least ten days prior to tender due date, from the undersigned with due written request.

6. BHEL reserves the right to go for a reverse auction (RA) instead of opening the submitted sealed bid, which will be decided after technical evaluation. Information and general terms and conditions covering RA are given in commercial terms and conditions (Annexure-A/Point no.15)

7. Corrigendum if any, with respect to this tender will be hosted only in the website <http://www.bhel.com> or <http://tenders.gov.in>. You are requested to visit the website regularly for updates.

8. BHEL will consider MSME vendor as per Government guidelines.

9. Vendors are requested to avoid the following points while submitting the Bid Documents:

- Loose or spiral bound bid documents are not encouraged.
- In case of any corrections/overwriting in the tender documents, the same shall be duly attested by the bid submitter.

10. Vendors representative having proper ID proof and authorization letter shall attend the tender opening.

The offers should reach us 30 minutes before the time of opening of tenders. The offers will be opened at 14.30 hrs on the due date of tender in the presence of tenderers who have submitted their offer and who may like to be present for the tender opening. Late and delayed offers are liable to be rejected.

Yours faithfully,
For **BHARAT HEAVY ELECTRICALS LIMITED**

MANAGER / PURCHASE
(FOSSIL BOILERS)
Yours faithfully,



BHARAT HEAVY ELECTRICALS LIMITED

(A Government of India Undertaking)
HIGH PRESSURE BOILER PLANT
PURCHASE DEPARTMENT - FOSSIL BOILERS
THIRUCHIRAPALLI - 620014
TAMILNADU (INDIA)

PHONE :2577645
GRAMS : BHARATELEC
FAX NO: 2520719
E-mail: srchandran@bheltry.co.in
Web:

Page
7/7

2681400039 / 16.12.2014

Enclosures:

"LD clause has to be confirmed without fail."

The offers should reach us 30 minutes before the time of opening of tenders.
The offers will be opened at 14.30 hrs on the due date of tender in the presence of tenderers who have submitted their offer and who may like to be present for the tender opening. Late and delayed offers are liable to be rejected.

Yours faithfully,
For **BHARAT HEAVY ELECTRICALS LIMITED**

MANAGER / PURCHASE
(FOSSIL BOILERS)
Yours faithfully,

BRAKE PANEL OUTER MODEL DIMENSIONAL DRAWING

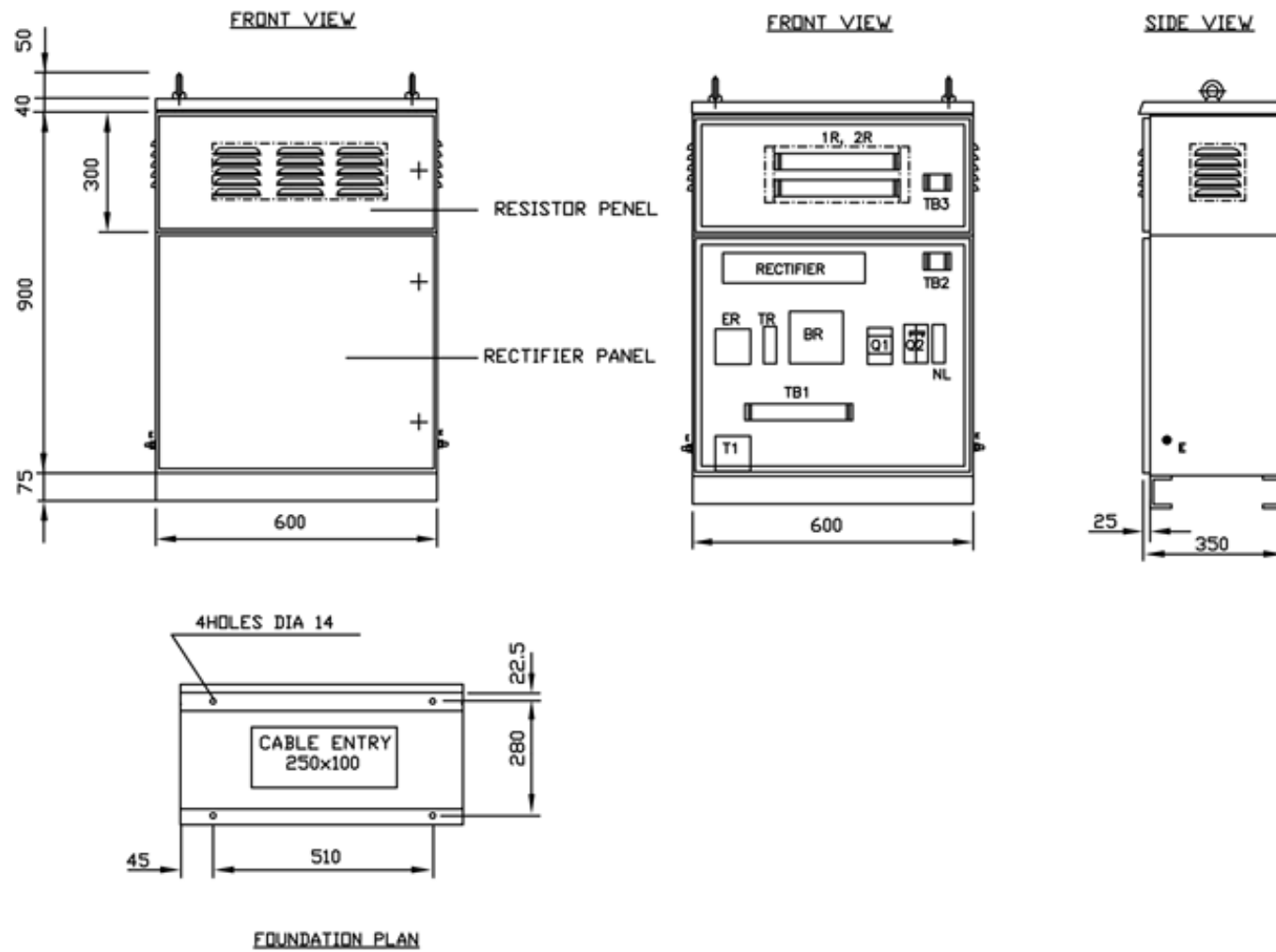

BRAKE PANEL ELECTRICAL CIRCUIT

415V.AC +10%-15%50Hz SUPPLY

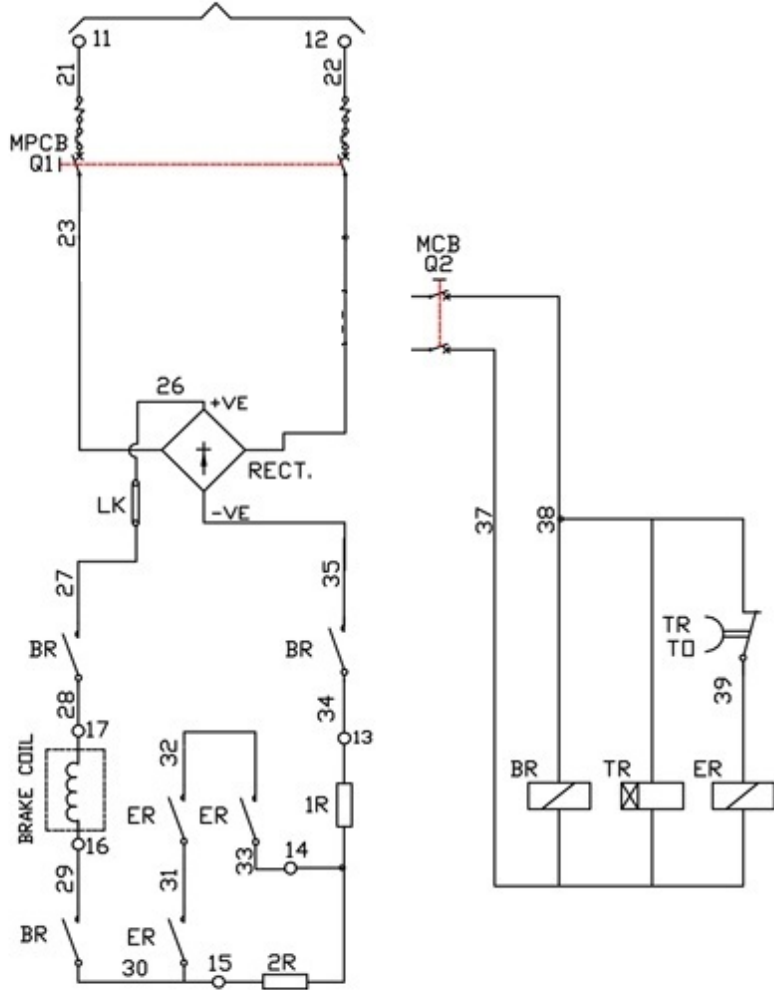

1R,2R	RESISTOR (200W)
Q1	MPCB
BR	BRAKE RELAY (40A)
ER	ECONOMY RELAY (40A)
TR	TIME DELAY RELAY (0.05-60SEC.)
CONTROL	2.5mm Sq BLACK PVC FLEXI. INSULATED CABLE
POWER	2.5mm Sq RED PVC FLEXI. INSULATED CABLE
CONT./POWER	CLIP - ON TYPE TERMINAL
Q2	MCB 2A,AC DP.

SIZE RESISTOR CONNECTED AT TB-3

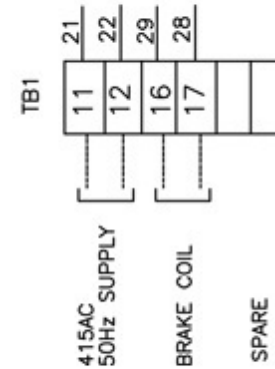
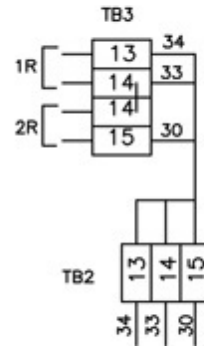
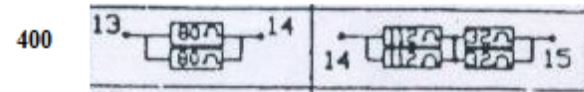
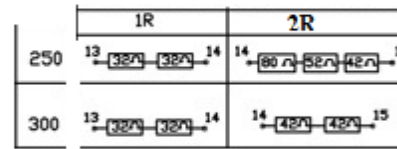

S NO	CRANE NO	SWL	LOCATION	BRAKE DIA	BRAKE TORQUE	BRAKE DRUM WIDTH
1	8015	30/5	BUL 1	300(MH)	-	-
				250(AH)	-	-
2	8100	10	BUL 1	300	-	-
3	8105	10	BUL 1	300	-	-
4	79108068	15/5	50/2	300 (MH)	34	150
				300(AH)	-	134
5	79108071	15/5	50/2	250(MH)	-	127
6	79108072	15/5	50/3	300(MH)	34	150
				250(AH)	13.8	125
7	79108077	10/5	50/5	380 (MH)	Shall be made 400	
				300(AH)	-	150
8	79108081	10	50/A	300	18	150
9	79108082	20/5	50/B	300 (MH)	34	140
				300(AH)	18	133
10	79108083	20/5	50/B	300(MH)	-	150
				250(AH)	34	125
11	79108078	10/5	50/5	380 (MH)	Shall be made 400	
				300(AH)	-	150
12	79108097	10	50/A	400	34	145

BHARAT HEAVY ELECTRICALS LIMITED TIRUCHIRAPALLI
CAPITAL PURCHASE

Annexure-A

ACCEPTANCE OF COMMERCIAL TERMS AND CONDITIONS BY THE VENDORS.

(This should be essentially filled in and sent along with the techno-commercial offer without fail. If this check list is not filled and submitted along with techno-commercial offer (Part I) or if the vendor does not confirm acceptance to the terms and conditions proposed herein, BHEL reserves the right to reject such offers)

CHECK-LIST FOR VENDORS

SI No	DESCRIPTION
1.	<p>The Bidders shall submit their offer in TWO INNER ENVELOPES as indicated below which shall be sealed in one outer envelope.</p> <ul style="list-style-type: none">❖ Envelope I: This sealed envelope should contain all the copies of technical bid together with un-priced commercial bid. This envelope should be clearly marked "Part I - Technical and commercial bid", indicating Enquiry No., Due Date and Address & Reference of the Bidder.❖ Envelope II: This sealed envelope should contain price details. This envelope should be clearly marked "Part II - Price bid", indicating Enquiry No., Due Date and Address & Reference of the Bidder. This part should contain the schedule of price particulars and must be co-related to the technical details provided in Part I. <p>All the two envelopes (Part I&II) shall be put in one cover, duly sealed, super scribing as "Part I and Part II of Enquiry No., due date of opening" and the address and reference of the Bidder. The offer received without the above guidelines, will not be considered for opening.</p> <p>The above offer should reach this office on or before the due date by 14.00 Hrs (IST). Late offers will not be considered. Tender should not be addressed to any Individual's name but only by designation to:</p> <p style="text-align: center;">DGM / CAPITAL PURCHASE / MFG 24 BUILDING, 4TH FLOOR BHARAT HEAVY ELECTRICALS LIMITED HIGH PRESSURE BOILER PLANT TIRUCHIRAPALLI - 620 014 TAMIL NADU, INDIA</p> <p>Tenders should be free from CORRECTIONS AND ERASURES. Corrections if any, must be attested. All amounts shall be indicated both in words as well as in figures. In case of any difference between amount quoted in words and figures, amount quoted in words shall prevail.</p> <p>Offers should be in ENGLISH and accompanied by detailed technical literature, catalogue and detailed dimensional drawings in ENGLISH or otherwise, the offers will not be considered.</p>
2.	<p><u>OPENING OF TENDERS</u></p> <p>The Part I- Technical & commercial bid would be opened on the Tender opening date.</p> <p>Part-II, Price bid of technically suitable Bidders alone would be opened after complete evaluation of Part-I. Hence the Bidders are required to submit their best competitive price in the price bid in a sealed cover (Part-II). In case of necessity BHEL reserves the right to go for a reverse auction (RA) instead of opening the submitted sealed bid, which will be decided after technical evaluation. Information and general terms and conditions covering RA are given in this Annexure- I (Point no.15).</p> <p>Date and time of Price Bid (Part-II) opening / RA conducting date shall be intimated to the technically and commercially acceptable bidders only. Clarifications if any required by BHEL for Technical evaluation would be sought from bidders before opening of Part II - Price Bid/ RA</p>
3.	<p><u>TAXES AND DUTIES :</u></p> <p>All Taxes and Duties payable as extra to the quoted price should be specifically stated in offers along with CST & TIN No / Tariff No. etc., failing which the purchaser will not be liable for payment of such Taxes and Duties. Our TIN No. 33243560005, TNGST No. 3560005, CST. No. 239383 Dt. 11-06-1991 & BHEL ECC No. AAACB4146PXM012, Service Tax Reg No (STC)- AAACB4146PST006. Assessment circle Tiruverambur.</p> <p>Cenvat credit & VAT credit (for Indian Bidders only): If any Excise Duty is payable, the chapter head / sub-head reference and the rate of the duty should be quoted. If the tenderer is availing CENVAT credit for his input materials, the effect of proforma credit should be passed on to the purchaser</p> <p>Income Tax applicable Any service charges payable towards supervision of E&C, training, performance prove-out etc., will be released after deduction of Income Tax as per Indian Income Tax Act / as per the Govt. of India rules and TDS certificate will be issued by BHEL for such deductions. Applicable service tax on E&C charges will be payable extra. The liability of depositing the same to the Govt. will be of the supplier</p>

No row shall be left blank. Please indicate NA, in case the item is “not applicable”		Vendor's confirmation
	Validity: Validity of the offer should be 120 days from the date of tender opening.	
4.	<p>Payment terms for Supply Portion Orders will be placed respective L1 vendor for each line items. 100% Payment after receipt and acceptance of material within 45-90 days against submission of 10%PBG for total order value.</p> <p style="color: red;">Any deviation in the above payment term will attract loading as mentioned below. “Base rate of SBI (as applicable on the date of bid opening. Techno-commercial bid opening in case of two part bids) + 6% shall be considered for loading for the period of relaxation sought by bidders.</p>	
5.	<p>Performance Bank Guarantee (PBG): The Bidder, in the event of an order, should furnish a Bank Guarantee from an Indian Bank approved by BHEL, at no extra cost in a format prescribed by BHEL, along with the order, for an amount equivalent to 10% (Ten percent) of the value of the contract. The PBG shall be valid for a period of 18 months from the date of dispatch or 12 months from the date of receipt / acceptance / commissioning of the equipment at BHEL, Tiruchi whichever is more, with a claim period of two months.</p> <p>The Performance Bank Guarantee shall be obtained from any one of the following banks which is a member bank in our consortium of banks. LIST OF CONSORTIUM BANKS 1.DEUTSCHE BANK 2.HDFC BANK 3.ANZ GRINDLAYS BANK 4.CITI BANK 5.STANDARD CHARTERED BANK 6.BANK OF AMERICA 7.ABN AMRO BANK 8.IDBI LTD 9.ICICI BANK LTD 10.THE HONGKONG AND SHANGHAI BANKING .CORPORATION LTD. LIST OF NATIONALISED BANKS 1.ALLAHABAD BANK 2.ANDHRA BANK 3.BANK OF INDIA 4.BANK OF BARODA 5.BANK OF MAHARASTRA 6.BHARATH OVERSEAS BANK 7.CANARA BANK 8.CENTRAL BANK OF INDIA 9.CORPORATION BANK 10.DENA BANK 11.INDIAN BANK 12.INDIAN OVERSEAS BANK 13.OREINTAL BANK OF COMMERCE 14.PUNJAB NATIONAL BANK 15.PUNJAB & SIND BANK 16.STATE BANK OF INDIA 17.STATE BANK OF TRAVANCORE 18.STATE BANK OF MYSORE 19.STATE BANK OF BIKANER & JAIPUR 20.STATE BANK OF HYDERABAD 21.STATE BANK OF PATIALA 22.STATE BANK OF MAHARASTRA 23.STATE BANK OF SOURASTRA(SBI-13.09.08) 24.SYNDICATE BANK 25.UCO BANK 26.UNION BANK OF INDIA 27.UNITED BANK OF INDIA 28.VIJAYA BANK</p> <p><u>If PBG is issued by a Foreign counter part of the BHEL consortium Indian Bank, in case of claim against the PBG , it will be lodged in any one of the Indian counters of the Foreign Bank which issued the PBG.</u></p>	
6.	<p>Liquidated damages (LD): The delivery of the goods specified in the purchase order should be made within the time prescribed. LD for delay in ‘Supply’ and/or ‘I&C’ will be applicable to the delays attributed to vendor. LD will be considered separately for ‘Delivery’ and ‘I &C’. Where the seller supplies or dispatches the goods, beyond the delivery period Liquidated damages shall be applicable 0.5% of the total order value per week or part thereof subject to a maximum of 10% of the total order value.</p> <p>The rate of LD for delayed E&C shall be @ 0.5% per week of delay of total PO value (Supply + I &C) in I &C subject to a maximum of 10% of total PO value (Supply + I&C).</p> <p>For staggered delivery schedule, LD shall be 0.5% of the undelivered portion per week of the delay or part thereof subject to a maximum of 10% of the total order value.</p> <p>Any deviation from the above LD clause, loading will be applied to the extent to which it is not agreed by the bidder (at offered value).</p>	
7.	<p>Risk Purchase: Alternatively the purchaser at his option will be entitled to terminate the contract and to purchase elsewhere at the risk and cost of the seller either the whole of the goods or any part which the supplier has failed to deliver or dispatch within the time stipulated as aforesaid or if the same were not available from the best and the nearest available substitute. The supplier shall be liable for any loss which the Purchaser may sustain by reason of such risk purchases.</p>	
8.	<p>Delivery terms and evaluation process: Indian Bidders should submit their offer on FOR BHEL, Tiruchy basis. Packing & Forwarding and Freight & Insurance charges from works to BHEL, Tiruchy to be indicated separately if extra from basic rate. Applicable % of ED & Sales Tax , Commissioning Charges should be clearly indicated.</p> <p style="background-color: yellow;">Evaluation of offers shall be on the basis of delivered cost (Net cash outflow to BHEL)</p>	
9.	<p>Guarantee: Vendors shall provide a guarantee for a period of 12 months from the date of commissioning of the equipment or 18 months from date of supply, whichever is earlier. The date of B/L or AWB shall be taken as the date of supply.Also, a PBG has to be given which shall cover the guarantee period (with additional 2 months as claim period). Normally No deviation permitted and the deviated offers are liable for rejection.</p>	
10.	<p>Short shipment / Warranty replacement: In case of any short shipment in the main equipment / spares, Customs Duty levied on such supplies, shall be borne by the supplier. Any warranty replacement during the warrantee period shall be on FOR, BHEL, Tiruchirappalli, basis.</p>	
11.	<p>Inspection & Testing: All goods shall be subject to inspection by BHEL or its authorized representatives at supplier's works or at BHEL stores or at any other place in India indicated by BHEL as the case may be. The supplier will not charge for the facilities provided for inspection of goods. In case of machine tools, the machine would be inspected and proved at supplier's works prior to dispatch however, final inspection and acceptance of the machine will be carried after installation of the machine at BHEL, Tiruchirappalli.</p>	

12.	<p>Test certificates / Operating and Maintenance manuals: The Bidders shall clearly mention in their offer, that Test Certificates and Operating Maintenance Manuals, etc., as called for in the Technical Specification, in the required number of copies will be provided at no extra cost.</p>	
13.	<p>Payment through Bank is not preferred. In case of Payment through Bank is opted by Supplier, BHEL prefers documents submission through bank with copy of LR and door delivery of Goods to Site/Stores with Consignee copy attached. In this case Loading will be 3% on the offered value. Offers of indigenous Suppliers with payment terms as LC/Advance Payment are liable for rejection.</p>	
14.	<p>BHEL will consider the ranking after the loading is applied as referred above wherever deviations are observed.</p>	
15.	<p>Reverse Auction (RA): BHEL reserves the right to conduct on-line internet Reverse Auction ie. ONLINE BIDDING (THROUGH A SERVICE PROVIDER) for finalizing the Tender. This decision will be communicated to the technically qualified vendors after technical evaluation. Details / General terms / guidelines for conduct of RA are shown below Vendors are requested to confirm their acceptance for BHEL proceeding with RA route for finalization of the enquiry.</p> <ol style="list-style-type: none"> 1. For the proposed reverse auction, technically and commercially acceptable bidders only shall be eligible to participate. 2. BHEL will engage the services of a service provider who will provide all necessary training and assistance before commencement of on line bidding on internet. 3. BHEL will inform the vendor in writing in case of reverse auction, the details of Service Provider to enable them to contact & get trained. 4. Business rules like event date, time, start price, bid decrement, extensions etc. also will be communicated through service provider for compliance. 5. Vendors have to fax the Compliance form in the prescribed format (provided by Service provider) before start of Reverse auction. Without this, the vendor will not be eligible to participate in the event. 6. BHEL will provide the calculation sheet (e.g., EXCEL sheet) which will help to arrive at "Total Cost to BHEL" like Packing & forwarding charges, Taxes and Duties, Freight charges, Insurance, Service Tax for Services and loading factors (for non-compliance to BHEL standard Commercial terms & conditions) for each of the vendor to enable them to fill-in the price and keep it ready for keying in during the Auction 7. Reverse auction will be conducted on scheduled date & time. 8. At the end of Reverse Auction event, the lowest bidder value will be known on the network. 9. The lowest bidder has to Fax/e-mail the duly signed Filled-in prescribed format as provided on case-to-case basis to BHEL through Service provider within 24 hours of Auction without fail. 10. Any variation between the on-line bid value and the signed document will be considered as sabotaging the tender process and will invite disqualification of vendor to conduct business with BHEL as per prevailing procedure. 11. In case BHEL decides not to go for Reverse Auction procedure for this tender enquiry, the Price Bids and price impacts, if any, already submitted and available with BHEL shall be opened as per BHEL's standard practice. 12. BHEL reserves the right to negotiate if need be, with the "L1" vendor of the Reverse Auction 13. <u>BHEL reserves the right not to consider offers from vendors not complying with the RA process for finalization of the enquiry.</u> 14. If the Bidder or any of his representatives are found to be involved in Price manipulation/ cartel formation of any kind, directly or indirectly by communicating with other bidders, action as per extant BHEL guidelines, shall be initiated by BHEL and the results of the RA scrapped/ aborted. <p>In case BHEL decides to go for reverse auction, the H1 bidder(s) (whose quote is highest in online sealed bid) may not be allowed to participate in further RA process.</p>	
16.	<p><u>Special Provisions for Micro and Small Enterprises (MSE)</u></p> <ol style="list-style-type: none"> 1. 20% of the tendered quantity is earmarked for MSE suppliers in this tender. 2. Out of the 20% tendered quantity reserved for MSE suppliers, 4% shall be earmarked for procurement from MSE owned by SC/ST entrepreneurs. 3. In case MSE vendor participating in the tender quotes within the price band of L1+15%, they will be allowed to supply the portion of the requirement subject to acceptance of L1 price by MSE vendor. In case of more than one such MSE, the supply shall be shared proportionately. 4. MSE suppliers can avail the intended benefits only if they submit along with offer, attested copies of either EM II certificate having deemed validity (Two years from the date of issue of acknowledgement in EM II) or valid NSIC certificate or EM II certificate along with CA certificate (Format enclosed Annexure - III) applicable for the year, certifying quantum of investment in plant and machinery within the permissible limit as per the act for relevant status (Micro or small) where the deemed validity of EM II is over. Date to be reckoned for determining the deemed validity will be the last date of technical bid submission. Offer/s received without these documents will lead to consideration of their offer at par with other bidders and MSE status of such suppliers shall be shifted to Non MSE supplier 	

17.	<ul style="list-style-type: none"> ➤ Point to point confirmation for the Technical Specification enclosed to be provided. If there are any deviations, the same should be clearly specified. Offers received without confirmation to our specifications will be liable for rejection. If needed additional sheets shall be used. ➤ Equipment offered shall be "New". Re-built / Re-conditioned / Used equipment's will not be accepted. Incomplete offers will not be considered for further processing Fixed price: ➤ BHEL reserves its right to reject a tender due to unsatisfactory past performance in the execution of a contract at any of BHEL projects / units. ➤ BHEL shall be at liberty to reject or accept any tender, part or in full, at their own discretion and any such action is not liable for any question or claim against BHEL. ➤ The vendor shall provide necessary drawings, Test Certificates and Operating Maintenance Manuals etc., as called for in the Technical Specification, in the required number of copies at no extra cost ➤ The Supplier shall arrange for securely protecting and packing the stores to avoid loss or damages during transit. 		
18.	Company Details & Contact		
	Full Address of the company for future correspondence. (Copy of address proof & PAN card shall be attached along with Part-I)		
	Company Email ID:	Phone No.:	
	Fax No	PAN No	
	CST /TIN No	Service Tax No.	
	Name of the contact person:	Mobile No.:	
	e-mail ID		
19.	TO BE CONFIRMED BY VENDOR		
	Country of origin:		
	Station of dispatch/Port of Shipment		
	Delivery Terms (For destination or Ex-works)		
20.	Packing & Forwarding Charges, if any (in % or Lumpsum) ie. extra from basic rate		
	% of Excise Duty with cess		
	% of TAX (CST/VAT) (TNGST with FORM-17 or CST with C-FORM)		
	Freight & Transit Insurance charges (if any, in Lumpsum (or) percentage) from Dispatching station to BHEL Tiruchirappalli, (Note:If the delivery terms is Ex Works the materials has to be sent through BHEL approved carrier only, in this case the Freight & Insurance will be borne by BHEL)		
21.	Delivery from the date of Letter of Intent / Purchase Order. (This should be inclusive of Order acceptance, drawing approval and time period required for receiving goods at BHEL Trichy etc.,		
22.	Weight & Cubage of package: Approximate Net weight of the total consignment: Approximate Gross weight of the total consignment: Approximate volume of the total consignment:		
For any queries / clarifications the bidders may contact us through our FAX NO. +91 431 2520719 or through e-mail <pgavictor@bheltry.co.in>			

NOTE

- a) Your specific acceptance to our Payment terms, LD, Risk Purchase Clause & Submission of PBG for 10% of the order value are essential for consideration of your offer. Otherwise your offer is liable for rejection.
- b) No row shall be left blank. Please indicate NA, in case the item is "not applicable"

Declaration:-

I/We have gone through and understood the 'General guidelines & instructions to bidders for submitting offer' enclosed as a part of the Tender and confirm that our offer has been made in line with the same.

Name: _____ Signature with date: _____ (AFFIX OFFICIAL SEAL HERE)
 Designation: _____
 (PLEASE AFFIX YOUR SIGNATURE WITH SEAL ON EACH PAGE)

MODEL PRICE BID FORMAT FOR INDIAN BIDDERS

Enquiry No. & Date:

Bidder's Offer No. & Date:

Sl No	Description of item	Unit (SET/ No)	QTY	Rate /Qty in Rs. (excluding of all taxes)	VAT/CST in % (TNGST with FORM-17 or CST with C-FORM)	ED in %	Total Value in Rs. (inclusive of all taxes)
	Packing & Forwarding charges (if any) in percentage (or) Lumpsum						
	FOR Dispatching station value in Rs.						
	Percentage of Freight & transit insurance charges, if any (Lumpsum or %) Freight & Insurance charges from Dispatching station to BHEL, Tiruchirappalli (Note:If the delivery terms is Ex Works the materials has to be sent through BHEL approved carrier only, in this case the freight & Insurane will be borne by BHEL)						
	Approximate Net weight of the total consignment						
	Approximate Gross weight of the total consignment						
	Approximate Dimensions of the Consignment						

Signature & Seal of Vendor

The price bid should be submitted only as per the above format. No row shall be left blank. Please indicate NA, in case the item is "not applicable"

Certificate by Chartered Accountant on letter head

This is to Certify that M/S
(hereinafter referred to as 'company') having its registered office at
..... is registered under MSMED Act 2006, (Entrepreneur
Memorandum No (Part-II) dtd:.....,
Category: (Micro/Small)). (Copy enclosed).

Further verified from the Books of Accounts that the investment of the company as on
date..... as per MSMED Act 2006 is as follows:

1. **For Manufacturing Enterprises:** Investment in plant and machinery (i.e. original cost excluding land and building and the items specified by the Ministry of Small Scale Industries vide its notification No.S.O.1722(E) dated October 5, 2006 :
Rs.....Lacs
2. **For Service Enterprises:** Investment in equipment (original cost excluding land and building and furniture, fittings and other items not directly related to the service rendered or as may be notified under the MSMED Act, 2006:
Rs.....Lacs

The above investment of Rs.....Lacs is within permissible limit of
Rs.....Lacs forMicro / Small (~~Strike off which is not applicable~~)
Category under MSMED Act 2006.

Date:

(Signature)

Name -

Membership number -

Seal of Chartered Accountant