

DETAIL 'C' 16 No., SS-304L

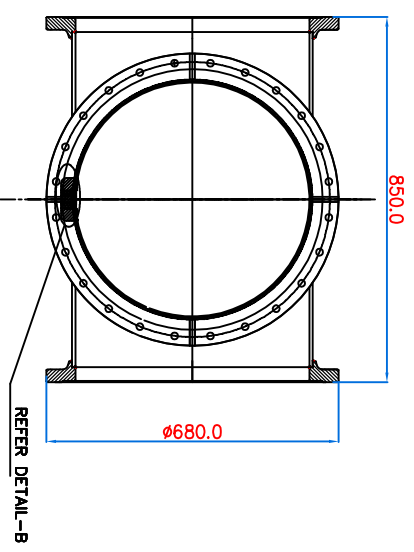

- NOTE:**
1. PIPE AND FLANGE TO BE MIG WELDING WITH SUITABLE SS ELECTRODE
  2. THE ROOT SHOULD BE HOMOGENEOUS AND CONTINUOUS.
  3. PRESSURE TEST AT 15.0 BAR FOR 15 MINUTS
  4. TESTED ASSEMBLIES TO BE DECREASED, SAND BLASTED AND POWDER COATED ON OUTSIDE.
  5. MAINTAIN PERPENDICULARITY AND PARALLARITY BETWEEN FLANGES WITHIN 0.1°
  6. INNER SURFACE OF ENCLOSURE SHALL BE ELECTROPOLISHED.

VAR. NO.	REMARKS	VAR. NO.	ITEM NO.	DESCRIPTION	QTY.	UNIT	ZONE
		01		STRAIGHT PIPE	02		
		02		FLANGE I	04		
		03		FLANGE II	02		
		04		FLANGE III	02		

TYPE OF PRODUCT  
NAME OF CUSTOMER  
**GSM-420**

DEPT.	GRADE OF TUB. DIM.	SCALE	WEIGHT(KG)
HYDERABAD	NTS	315.5	

DRN	NAME	SIGN.	DATE	NO. OF
KSRAO			26/12/06	VAR.
MARRAO			02/01/08	
MARRAO			07/01/08	01

INVENTORY NO.	SIGN. AND DATE	REF. DRG. NO.
---------------	----------------	---------------

REV.	DATE	ALTERED	REV.	DATE	ALTERED
		CHECKED			CHECKED

DEPT.	SCALE	WEIGHT(KG)	NO. OF SHEETS
4-WAY ENCLOSURE ASSY	NTS	315.5	1

FINAL ON 29/05/14

THE INFORMATION ON THIS DOCUMENT IS THE PROPERTY OF BHARAT HEAVY ELECTRICALS LIMITED. IT MUST NOT BE USED DIRECTLY OR INDIRECTLY IN ANY WAY DETRIMENTAL TO THE INTEREST OF THE COMPANY.

INVENTORY NO.	SIGN. AND DATE	REF. DRG. NO.
---------------	----------------	---------------

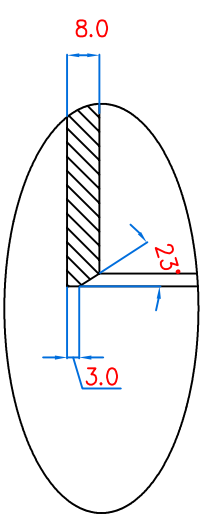
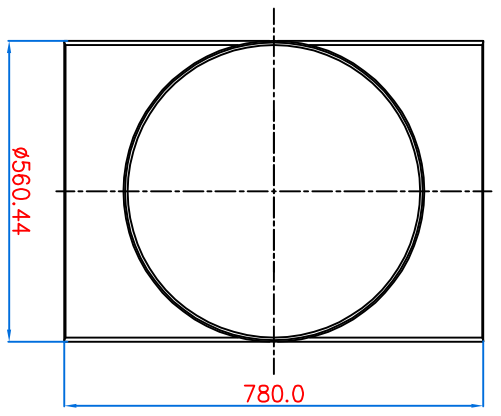
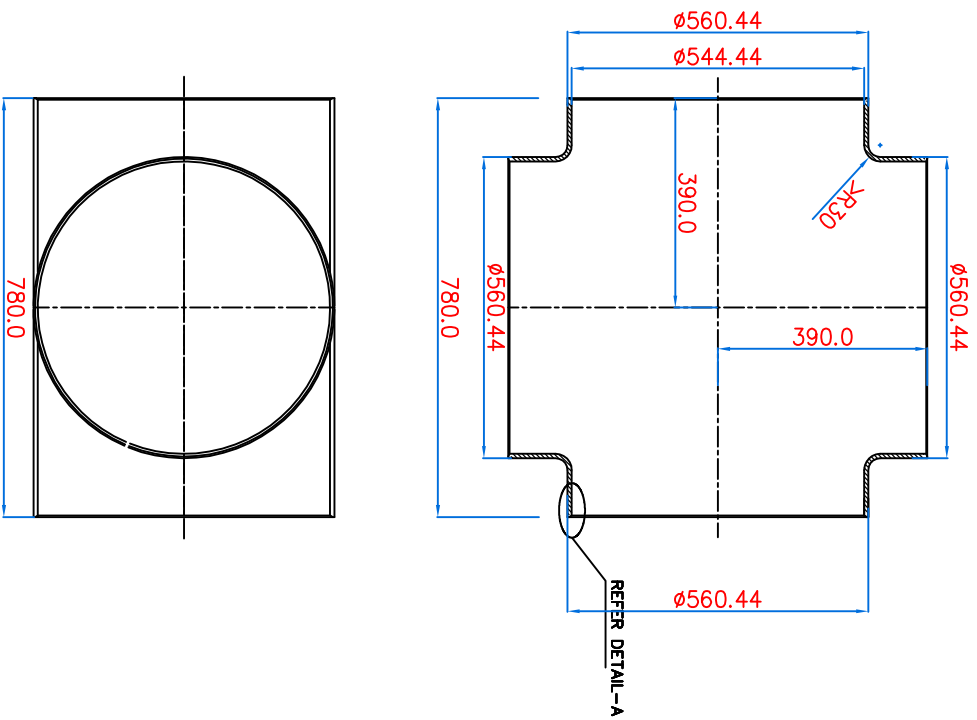

DETAIL-A

1. ALL SHARP EDGES OF THE PIPE SHALL BE MACHINED TO 0.4x45°.
2. PIPE SHALL BE GROUNDED TO THE DIMENSIONS.

VAR. NO.	REMARKS	VAR. NO.	ITEM NO.	DESCRIPTION	DR. NO.	ITNO.	MATL. CODE	MATL. SPECN.	A	UNIT WGT.	QTY.	ZONE
			01	STRAIGHT PIPE	RD DG 4 35 0617 0011		SS-304			02		

TYPE OF PRODUCT: GSM-420  
 NAME OF CUSTOMER: BHARAT HEAVY ELECTRICALS LTD. HYDERABAD

DRN. NAME	SIGN.	DATE
KSRRAO		26/12/05
MMRRAO		02/01/06
APRD. NAME	SIGN.	DATE
MMRRAO		02/01/06

DEPT. CODE	GRADE OF TOL. DIM. C/M/M	SCALE	WEIGHT(KG)
		NTS	

TITLE	CARD CODE	DR. NO.	NO. OF SHEETS
STRAIGHT PIPE		RD DG 4 35 0617 0011	1

FINAL ON 29/05/14

REV.	DATE	ALTERED CHECKED	REV.	DATE	ALTERED CHECKED	ZONE

THE INFORMATION ON THIS DOCUMENT IS THE PROPERTY OF BHARAT HEAVY ELECTRICALS LIMITED. IT MUST NOT BE USED DIRECTLY OR INDIRECTLY IN ANY WAY DETRIMENTAL TO THE INTEREST OF THE COMPANY.

INVENTORY NO. SIGN. AND DATE REF. DRG. NO.

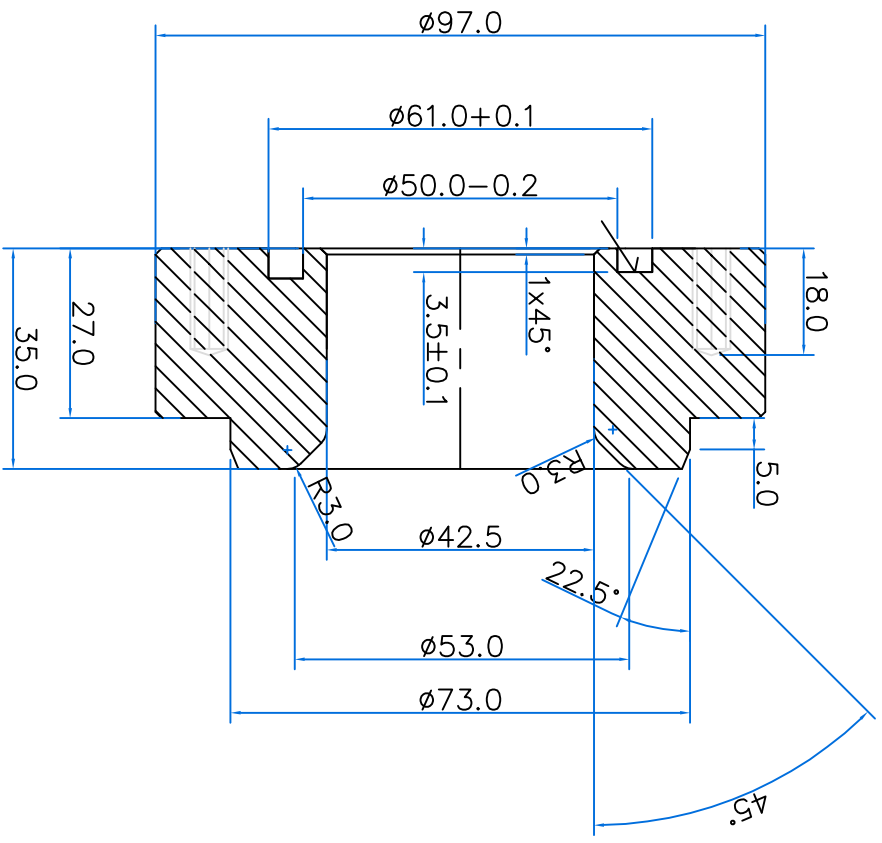

29/05/14

6 No., M6 TAPS @ 80.0 PCD, 18.0 deep

VAR. NO.	REMARKS	VAR. ITEM NO.	DESCRIPTION	STD	DRAWING NO.	IT. NO.	MATL. CODE	A	UNIT	UNIT WGT.	QTY.	SS	ZONE
		01	SS BLANK		Ø100.0X40.0		SS-304L				01		

TYPE OF PRODUCT  
NAME OF CUSTOMER  
**GSM-420**

DEPT.	GRADE OF TOL. DIM. C/M/F	SCALE	WEIGHT(KG)
BHARAT HEAVY ELECTRICALS LTD.	HYDERABAD	NTS	

REV.	DATE	ALTERED	REV.	DATE	ALTERED	ZONE	ZONE
		CHECKED			CHECKED		

DRN	NAME	SIGN.	DATE	NO. OF
CKD	KSRAO		28/12/05	VAR.
APPD	MMRRAO		02/01/08	NO.
			09/01/08	01

TITLE	CARD CODE	NO. OF SHEETS
FLANGE-II	PD DG 4 35 0617 0012	1



