



ISO 9001:2008  
& 14001:2004  
NAVARATNA  
COMPANY

(31)

**MATERIAL MANAGEMENT (PURCHASE)**  
**CENTRAL FOUNDRY FORGE PLANT, BHEL HARDWAR**  
RANIPUR, HARIDWAR (INDIA) – 249403  
Phone No. +91-1334-281277/284684, FAX No. 225892  
**e-mail : [ranjank@bhelhwr.co.in](mailto:ranjank@bhelhwr.co.in); [kraj@bhelhwr.co.in](mailto:kraj@bhelhwr.co.in);**  
**[amitkg@bhelhwr.co.in](mailto:amitkg@bhelhwr.co.in)**

**Sub:** Tender Enquiry No: 4408P/930/4/0496V1 Due on 27.02.2015 at 2.00 PM.

Dear Sir,

We are pleased to invite offer as per enclosed specifications with terms and conditions in sealed covers for the under mentioned items.

SI No	Tender No	Description of Material	Qty	Date & Time of Opening
01	4408P/930/4/0496V1	Ingot Mould 1300 mm, 1400 mm	08 Nos	27.02.2015 at 2.00 PM

**KINDLY READ TERMS AND CONDITIONS. OFFER NOT IN ACCORDANCE WITH THE INSTRUCTIONS IS LIABLE TO BE DISQUALIFIED OR IGNORED.**

Please visit [www.bhel.com](http://www.bhel.com) or [www.bhelhwr.co.in](http://www.bhelhwr.co.in) for more details and tender documents.

Unregistered vendors should download Vendor Registration Form and submit same duly filled along with offer.

Thanking You,

Yours Faithfully,  
For & On behalf of CFFP, BHEL, Hardwar

  
(Amit Kumar Gupta)  
Sr. Engineer (Purchase)

**Note:** Corrigendum if any shall not be published, kindly refers websites for any changes.



निविदा सूचना  
**TENDER ENQUIRY**

AA-17001

भारत हैवी इलैक्ट्रिकल्स लिमिटेड

**Bharat Heavy Electricals Ltd**

सेन्ट्रल फाउन्ड्री फॉर्ज प्लांट- हरिद्वार-249 403 (भारत)

**Central Foundry Forge Plant, Hardwar-249 403 INDIA**

30

Phone : (0091) (133) 485356, 485269

• Telefax : (0091) (133) 425892 • Telex : 05909-213

UPTT NO. HR-0041496 Dt. 01-04-1994  
C S T NO. HR-5018287 Dt. 16-03-1995

निविदा सूचना सं. ENQUIRY NO.*	4408 P/ 930/4/0496V1	दिनांक Date	05-02-2015
-------------------------------	----------------------	-------------	------------

कृपया निम्नलिखित के लिए निविदा दें। PLEASE QUOTE FOR THE FOLLOWING :

Office Copy

DUEDATE

27-02-2015

09285 M/s : : :  
: : INDIA

Item Description	Quantity	Unit	Lot	Quantity	Lot	Date
1 FF1978099100 DRG: 1300MM(02-148) REV: INGOT MOULD (1300MM(02-148))	5		NO			Delivery Schedule & Delivery term as per annexure-II. <u>अतिरिक्त</u>
2 FF1978099118 DRG: 1400MM(02-149) REV: INGOT MOULD [1400MM(02-149)]	3		NO			Delivery Schedule & Delivery term as per annexure-II. <u>अतिरिक्त</u>

\*\* IMPORTANT: This enquiry is 2 part tender. Techno-Commercial bid (Part-1) & Price Bids (Part-2) should be submitted in separate envelopes. These two envelopes should be submitted in a common sealed envelope. Techno-Commercial Bid shall contain detailed Technical Specification, Drawings Technical documents, Catalogues, taxes & duties, payment terms, delivery period, Validity of offer, Replica of Price Bid (Copy of price bid without price part) etc. The confirmation to the special terms & conditions must be submitted alongwith Techno-Commercial bid.

## Standard Instructions:

TEST CERTIFICATE REQUIRED.  
GUARANTEE CERTIFICATE REQUIRED.  
BASIC RATES, TAXES DUTIES SEPERATELY  
CENVATABLE DUPLICATE COPY OF INVOICE.  
INSP AFTER RECPT AT CFPP.

## Special Instructions:

DRAWINGS ARE ENCLOSED.  
CASTING TO BE SUPPLIED IN MACHINED CONDITIONS DULY STRESS RELIEVED.  
TIN (SN) SHALL BE 0.005% MAX INPLACE OF 0.05% MAX.  
ARSENIC (AS) SHALL BE 0.005% MAX.  
LEADE (PB) SHALL BE 0.0003% MAX.

## General Instructions:

1. Please submit authorization letter (format enclosed) for facilitating e-payment/electronic transfer of funds
2. 100% payment within 30 days after receipt & acceptance of material at CFPP BHEL, Hardwar through e-payment.
3. CFPP/BHEL RESERVES THE RIGHT TO PRE-INSPECT THE MATERIAL AT VENDOR'S WORKS / GODOWN/ PREMISES BEFORE DESPATCH.
4. ORIGINAL MANUFACTURER'S TEST CERTIFICATE IS REQUIRED ALONG WITH DESPATCH



निविदा सूचना  
**TENDER ENQUIRY**

AA-17001

भारत हैवी इलैक्ट्रिकल्स लिमिटेड  
**Bharat Heavy Electricals Ltd**

सेन्ट्रल फाउन्ड्री फॉर्ज प्लांट- हरिद्वार-249 403 (भारत)

**Central Foundry Forge Plant, Hardwar-249 403 INDIA**

29

Phone : (0091) (133) 485356, 485269

• Telefax : (0091) (133) 425892 • Telex : 05909-213

UPTT NO. HR-0041496 Dt. 01-04-1994  
C S T NO. HR-5018287 Dt. 16-03-1995

निविदा सूचना सं. ENQUIRY NO.*	4408 P/ 930/4/0496V1	दिनांक Date	05-02-2015
-------------------------------	----------------------	-------------	------------

कृपया निम्नलिखित के लिए निविदा दें। PLEASE QUOTE FOR THE FOLLOWING :

Office Co

SL	MATERIAL CODE	QUANTITY	UNIT	LOTNO	LOT DELIVERY QTY SCHEDULE
----	---------------	----------	------	-------	---------------------------

DOCUMENTS. IN CASE SUPPLIES ARE FROM TRADERS, IT SHALL BE THE RESPONSIBILITY OF THE TRADER TO PROVIDE ORIGINAL MANUFACTURER'S TEST CERTIFICATE WITH LINKAGE TO TRADER'S INVOICE STATING BATCH NO.

5. CFEP/BHEL Reserves the right to procure from more than one vendor.

6. Please quote prices in figures & words both. In case the prices quoted in words and figures are different, the values indicated in words will be considered for evaluation & establishing L1 status.

\* The offers of the bidders who are on the banned list as also the offers of the bidders, who engage the services of the banned firms, shall

be rejected. The list of banned firms is available on web site [www.bhel.com](http://www.bhel.com)

*(Signature)*  
05/02/15  
AMIT KUMAR GUPTA

SR. ENGINEER

**COMMERCIAL TERMS & CONDITIONS**

Tender Enquiry No.: 4408P/930/4/0496V1

	Conditions	Vendor's Confirmation / Comments.
1	<p><b>PRE QUALIFICATION CRITERIA:-</b></p> <ol style="list-style-type: none"> <li>1. The vendor must have supplied at least one number Cast Iron Mould of minimum single piece delivery weight 20 MT within last 3 year of date of tender opening.</li> <li>2. As a supporting document of point (1) copy of Purchase orders/Purchase Agreements/Invoice has to be provided by the vendor.</li> <li>3. PMD approved Vendors at CFFP for item Ingot Mould will be taken as Qualifying vendors</li> </ol>	
	<b>TECHNO-COMMERCIAL TERMS:-</b>	
2	<p>Material- shall be supplied as per requirement of tender enquiry in all respects.</p> <p>Casting to be supplied in machined condition duly stress relieved.</p> <p>Tin (Sn) shall be 0.005% max inplace of 0.05% max.</p> <p>Arsenic (As) shall be 0.005% max.</p> <p>Lead (Pb) shall be 0.0003% max.</p>	
3	<p>Guarantee certificate shall be provided by the seller along with despatch documents confirming that in case of any non-conformity with respect to the supplier material shall be replaced free of cost</p>	
4	<p>Test Certificate (with linkage to supplied material) shall be provided along with dispatch documents.</p>	
5	<p>Final inspection of material will be done after receipt of material at CFFP. All the charges (like To &amp; Fro freight, insurance etc.) for replacement shall be borne by supplier. Date of receipt of replacement material if accepted shall be considered as actual delivery date with respect to the PO delivery date for calculating penalty for Late Delivery.</p>	
6	<p><b>Delivery Term :-</b></p> <ol style="list-style-type: none"> <li>A. <u>For Indian Suppliers:</u> <b>FOR</b>, Destination (Door delivery basis). Destination will be C.Store, CFFP, BHEL, Haridwar.</li> <li>B. <u>For Foreign suppliers:</u> must essentially be <b>FOB</b> - Sea port of dispatch. Dispatching port &amp; Country to be mentioned essentially in the offer. Sea freight charges and inland freight (in India) &amp; Insurance for import will be arranged by CFFP BHEL Haridwar. Total weight - Gross / Net in Kg of packages, package size / dimensions essentially should be indicated in</li> </ol>	

	<p>the offer. Transportation and insurance charges will be calculated on the basis of same to decide L1 offer. In case any additional charges incurred by CFFP BHEL later on due to change/deviation in packages weight / size, actual difference will be to vendor's account.</p> <p>Quoted rate should be inclusive of the charges like freight, service tax on freight, insurance, packing &amp; forwarding etc. <u>for the delivery term</u> given above or else proper loading shall be done.</p>	
7	<p><b>Delivery Schedule :-</b></p> <p>A. For Indian Suppliers: In one lot - within 60 days from P.O. date</p> <p>B. For Foreign suppliers: In one lot F.O.B. delivery—within 30 days from L.C./P.O. date, whichever is later. L.D. will be applicable as per above mentioned delivery Schedule. Vendor is requested to quote earliest possible delivery schedule.</p>	
8	<p><b><u>Conditions for opening of Price :-</u></b></p> <ol style="list-style-type: none"> <li>1. BHEL reserves the right to go for Reverse Auction (RA) instead of opening the sealed envelope price bid, submitted by the bidder. This will be decided after techno-commercial evaluation. All bidders to give their acceptance for participation in RA. Non-acceptance to participate in RA may result in non-consideration of their bids, in case BHEL decides to go for RA.</li> <li>2. In case BHEL decides to go for Reverse Auction, Only those bidders who have given their acceptance to participate in RA will be allowed to participate in the Reverse Auction. Those bidders who have given their acceptance to participate in Reverse Auction will have to necessarily submit „online sealed bid“ in the Reverse Auction. Non-submission of „online sealed bid“ by the bidder will be considered as tampering of the tender process and will invite action by BHEL as per extant guidelines in vogue.</li> <li>3. In case BHEL decides to go for Reverse Auction, the H1 bidder (whose quote is highest in online sealed bid) may not be allowed to participate in further RA process.</li> </ol>	
9	<p>Payment Terms: <b><u>For Indian suppliers</u></b> - 100% within 30 days after receipt &amp; acceptance of material at CFFP / BHEL, Haridwar through e-payment. In case vendor does not agree, proper loading shall be done</p> <p>Loading will be @ Base rate of SBI (as applicable on the dated of bid opening, Techno-commercial bid opening in case of two part bids) + 6%, shall be considered for loading for the period of relaxation sought by bidders.</p> <p><b><u>For foreign suppliers:</u></b> Payment through USANCE LC on 70th day of bill of lading date. All bank charges shall be to vendor's account. In case vendor does not agree, proper loading shall be done. Loading will be @ Base rate of SBI (as applicable on the dated of bid opening, Techno-commercial bid opening in case of two part bids) + 6%, shall</p>	

	be considered for loading for the period of relaxation sought by bidders.	
10	Validity of offers : minimum 90 days from tender opening date	
11	Evaluation of price bids will be done on the basis of total delivered cost at CFFP i.e. Landed cost net of Cenvat at CFFP.	
12	BHEL may place order for part quantity. Quoted rate not to be linked with order quantity.	
13	Rates shall be Firm till execution of purchase order.	
14	Material will be supplied as per delivery schedule required in tender enquiry / PO (FOR destination basis). Any request for extension in delivery schedule of Purchase Order / waiver of LD is liable to be ignored.	
15	<p>Normal clauses for imposing Penalty, Liquidated Damages for Late Delivery, Risk purchases, Cancellation, Arbitration in case of delay in effecting supply and or other defaults as per following conditions will be applicable:</p> <p>a. Penalty for Late Delivery: The delivery of the goods shall be made strictly as per time limit specified in delivery schedule, failure to supply within this period will make the seller liable to a penalty of 1/2 (half) percent of the price of the goods in arrears per week subject to a maximum of 10% on the basic rate (total PO value). Any correspondence regarding waiver of LD shall not be entertained. In case supplier does not agree for LD clause, BHEL will load maximum penalty under LD clause, to the extent the same is not agreed by the vendor, for the purpose of comparative statement. Where deliveries quoted are not suiting, BHEL may ignore the offer.</p> <p>b. Risk Purchase: In case of delays in supplies / defective supplies or non-fulfillment of any other terms and conditions given in the Purchase Order by the seller, the Buyer reserves the right to cancel the purchase order in full or part thereof, and may also make the purchase of such material from alternative source <u>at the risk and cost of the seller.</u></p>	
16	For new vendors who are not registered with CFFP BHEL Haridwar, duly filled up "Supplier Registration Form" (available at <a href="http://www.bhel.com">www.bhel.com</a> ) along-with all the supporting documents has to be submitted along-with techno-commercial bid of offer. Please confirm that SRF is being submitted with your offer if applicable. However please note that if in any case duly filled up SRF is not received within 15 days of tender opening, your offer may liable to be ignored.	
17	BHEL will prefer to deal directly with foreign vendor/ original manufacturer. In case, vendor engages any Indian agent or take service of any Indian agent, copy of agent agreement required along with offer in line with Annexure-IV attached.	

18	In the event of any dispute arising out of contractual obligation, the order being finalized at Haridwar, India will be subject to Indian Laws and falls under jurisdiction of the court of Law at Haridwar, India.	
19	Indian Vendors shall quote their price only in INR. Foreign vendors shall quote their price only in USD, EURO, UK POUND STERLING and JAPANESE YEN.  For evaluation of price bids, exchange rate (TT selling rate of SBI) as on scheduled date of tender opening (Part-1 bid in case of two part bid) shall be considered.	
20	Vendor shall quote price both in words & figures. If there is any difference between price quoted in words & figures, price quoted in words shall prevail and binding.	
21	Please provide contact person name, telephone nos. , fax no. & email id.	
22	A. In case of any difference in conditions quoted above & elsewhere in the offer, terms quoted above shall be treated as final and binding on vendor.  B. Non acceptance of any of the above conditions may result in rejection of your offer.  C. Terms & Conditions not specified above will be as per Annexure-B No GTCRM NO. 01 Rev.05 Date: 25.10.12 enclosed.  D. In case of blank / no comments in provided remark column, it shall be deemed to have been accepted by vendor.	

Date:

Signature with Name of authorized signatory)

Seal of the Company

GENERAL TERMS AND CONDITIONS OF TENDER ENQUIRY  
ANNEXURE-B

01 Submit the tender in two parts i.e.

- Part-I Techno-Commercial Bid**
- Part-II Price Bid**

Techo - Commercial (part one) Price Bid (part two) should be put in separate sealed envelopes. Both envelopes should be super scribed with **Tender Number, Date of opening & Technical / Commercial Bid and Price Bid** respectively along with name of firm.

Both the envelopes i.e. containing Techno-Commercial Bid and Price Bid should again be kept in one envelope super scribed again with Tender No. and Date of opening and the name of firm submitting the tender and send it to **AGM (MM), Purchase Department, CFFP/BHEL, Hardwar, Ranipur, Hardwar 249403, Uttarakhand, India before due date / tender opening date & time.** Normally tender opening time is 2.00 PM on due date or as mentioned in enquiry.

**Responsibility for submission of tender in time solely lies with vendor. Late offers received after specified time / Date shall not be considered.**

1. Part-I Envelopes super scribed with **Techno-Commercial Bid** must contain all information especially-
  - (a) Specification of the material offered should be strictly as per CFFP/BHEL specifications of enquired material in tender documents **Deviations if any must be indicated clearly in the offer. Rates to be quoted on For Destination Basis.**
  - (b) All commercial terms i.e. packing, forwarding Custom duty, Additional Duty, ST/STT/VAT/CST, Excise Duty/CVD, Bank charges, payment terms & insurance etc as applicable (**except price**) should be clearly mentioned in Techno-Commercial bid. Also mention present rate of applicable taxes & duties even if inclusive in rates along with the concessional forms required if any.
  - (c) Confirm to submit all required commercial documents (tax invoice centvatable duplicate copy of invoice, packing list, transit sale agreement etc.) & technical documents (TC/GC/QP etc).
  - (d) Registration Numbers of SSI, Central Excise, Sales tax, Income Tax, DGS & D.ECC etc.
  - (e) **Un-priced copy of Price Bid.**

Part-II Envelopes super scribed with Price Bid should contain priced copy of Price Bid. The price should be mentioned both in figures and words.

2. Authorized Signatory should authenticate all tender documents.
3. **Techno-commercial bid (Part-I)** will be opened on the due date at 2.00 PM in the presence of participating vendors or authorized representatives, who may wish to be present. Representative deputed to witness tender opening must produce an authority letter from the signatory of offer. After evaluation of technical bids & finalization of technical, commercial terms & conditions, price bid of only successful vendors will be opened. Priced bid opening date shall be intimated separately.
4. The material offered must conform to the required BHEL specifications and drawings as well as instructions and details made available.
5. For new vendors, Vendor Registration form duly filled must be submitted along with the offer which can be downloaded from our web site [www.bhel.com](http://www.bhel.com) or [www.bhelhwr.co.in](http://www.bhelhwr.co.in).
6. Original manufacturer's Test Certificate is required along with dispatch documents. In case supplies are from traders, it shall be the responsibility of the trader to provide original manufacturer's test certificate with linkage to traders invoice stating batch no.
7. **Validity** of offers should be minimum 90 working days from the date of tender (Techno-Commercial Bid) opening.

- 8. **Delivery** in the promised period is the essence of contract. Confirm to supply according to delivery schedule mentioned.
- 9. **Payment terms:**  
 For indigenous suppliers: 100% within 30 days after receipt & acceptance of material at CFFP / BHEL, Haridwar through e-payment.  
 For foreign suppliers: Payment through USANCE LC on 70<sup>th</sup> day of bill of lading date. All bank charges shall be to vendor's account.  
  
 \* In case vendor does not agree, proper loading shall be done. Also in that case, third party inspection shall have to be arranged by supplier from any of the five inspection agencies namely: LRS/ BVQI/ DNV/ TUV/ Alfred H Knight at their cost.
- 10. CFFP/BHEL, Hardwar reserves the right to accept or reject any or all tenders without assigning any reason thereof.
- 11. Tenders not submitted in the prescribed manner are likely to be ignored / rejected.
- 12. **Agent/Agency Commissioning:** Payment of any kind at any stage will not be made to agent on account of agent commission or otherwise by CFFP/BHEL, Hardwar.
- 13. CFFP/BHEL, Hardwar may opt for E-auction/Reverse auction for obtaining best prices for part or full tendered quantity. BHEL also reserve the right to negotiate price with L1 vendor after reverse auction.
- 14. Please do intimate the personal contact details like Name, Mobile Number, Email-id etc of authorized executive for correspondence.
- 15. **Penalty:** Orders placed against this enquiry will be subject to normal clauses for imposing penalty. Liquidated Damages, Risk purchases, cancellation, arbitration as per terms and conditions of Tender Enquiry and Purchase orders in case of delay in effecting supply and/ or other defaults.  
**Liquidated damage:** The delivery of the goods shall be made strictly as per time limit specified in delivery schedule, failure to supply within this period will make the supplier liable to an conditional penalty of 1/2 (half) percent of the price of the goods in arrears per week subject to a maximum of 10%.
- 16. **Inspection:** Final inspection of material shall be done after receipt of material at CFFP/BHEL, Hardwar. Acceptance of material shall be after final inspection and shall be binding. However, CFFP reserves the right to pre Inspect the material at supplier works. In case material is found defective during warranty period, the same will be returned for repair and/ or replacement. For this vendor has to bear all the charges such as Freight, to and fro insurance etc. Bank Guarantee for the equal amount to the cost of the item is to be furnished by vendor. In case the repair is done at CFFP/BHEL the amount on actual shall have to be reimbursed by the Vendor and or adjusted on actual from their bill.
- 17. **Currency of Payment:** Mention the currency in which payment has to be made. For evaluation of price bids, exchange rate (TT selling rate of SBI) as on scheduled date of tender opening (Part-1 bid in case of two part bid) shall be considered.
- 18. Traders should submit authorization letter from their principal alongwith offer.
- 19. **Disputes:** In event of any dispute arising out of contractual obligation, the order being finalized at Hardwar, India will be subject to Indian Laws and falls under jurisdiction of the court of Law at Haridwar, India. The overseas supplier hereafter referred to as "Vendor" shall therefore abide by the verdict of Court of Law at Hardwar, India.  
 OR  
 All disputes arising out of or in connection with the present contract, if any shall be finally settled under the rules of arbitration of International chamber of commerce by one or more arbitrator appointed in accordance with the said Rules in India.
- 20. BHEL reserves the right to place P.O. for part / full qty and on one or more than one sources.
- 21. Any Term & condition of the specific tender (if specified in tender & contradicts with above term) will supersede the above general terms & conditions.

**Terms and conditions regarding Indian agent of foreign suppliers:**

- 01. BHEL shall deal directly with foreign vendors, wherever required, for procurement of goods. However, if the foreign principal desires to avail of the services of an Indian agent, then the foreign principal should ensure compliance to regulatory guidelines- which require mandatory submission of an Agency agreement.
- 02. It shall be incumbent on the Indian agent and the foreign principal to adhere to the relevant guidelines of Government of India, issued from time to time.
- 03. The agency agreement should specify the precise relationship between the foreign OEM/Foreign principal and their Indian agent and their mutual interest in the business. All services to be rendered by agent/associate, whether of general nature or in relation to the particular contract, must be clearly stated by the foreign supplier / Indian agent. Any payment, which the agent or associate receives in India or aboard from the OEM, whether as commission or as a general retainer fee should be brought on record in the agreement and be made explicit in order to ensure compliance to laws of the country.
- 04. Any agency commission to be paid by BHEL to the Indian agent shall be in Indian currency only.
- 05. Tax deduction at source is applicable to the agency commission paid to the Indian agent as per the prevailing rules.
- 06. In the absence of any agency agreement, BHEL shall not deal with any Indian agent (authorized representatives/ associate/consultant, or by whatever name called) and shall deal directly with the foreign principal only for all correspondence and business purposes.
- 07. The "Guidelines for Indian Agents of Foreign Suppliers" enclosed at annexure- 'A' shall apply in all such cases.
- 08. The supply and execution of the Purchase Order (including indigenous suppliers/service) shall be in the scope of the OEM/ Foreign principal. The OEM/ Foreign principal should submit their offer inclusive of all indigenous suppliers/services and evaluation will be based on 'total cost to BHEL'. In case OEM/ foreign principal recommends placement of order(s) towards indigenous portion of supplies/services on Indian Supplier (s)/ agent on their behalf, the credentials/capacity/capability of the Indian Supplier (s)/ agent to make the supplies/Services shall be checked by BHEL as per the extant guidelines of Supplier Evaluation, Approval and Review Procedure (SEARP), before opening of price bids. In this regards, details may be checked as per Annexure- 'B' (copy enclosed). It will be the responsibility of the OEM/ Foreign Principal to get acquainted with the evaluation requirements of Indian supplier/agent as per SEARP available on [www.bhel.com](http://www.bhel.com).

The responsibility for successful execution of the contract (including indigenous supplies/services) lies with the OEM/ foreign principal. All bank guarantees to this effect shall be in the scope of the OEM/Foreign principal.

**Guidelines for Indian Agents of Foreign Suppliers**

- 1.0 There shall be compulsory registration of agents for all Global (Open) Tender and Limited Tender. An agent who is not registered with BHEL shall apply for registration in the registration form in line with SEARP.
- 1.1 Registered agents will file an authenticated Photostat copy duly attested by a Notary Public/Original certificate of the Principal confirming the agency agreement and giving the status being enjoyed by the agent and the commission/ remuneration/ salary/ retainership being paid by the principal to the agent before the placement of order by BHEL.
- 1.2 Wherever the Indian representatives have communicated on behalf of their principals and the foreign parties have stated that they are not paying any commission to the Indian agents, and the Indian representative is working on the basis of salary or as retainer, a written declaration to this effect should be submitted by the party (i.e. Principal) before finalizing the order.
- 2.0 Disclosure of particulars of agents/ representatives in India, if any.**
- 2.1 Tenderers of Foreign nationality shall furnish the following details in their offers:
- 2.1.1 The Bidder(s)/ Contractor(s) of foreign origin shall disclose the name and address of the agents/ representatives in India if any and the extent of authorization and authority given to commit the Principals. In case the agent/ representative be a foreign Company, it shall be confirmed whether it is existing Company and details of the same shall be furnished.
- 2.1.2 The amount of commission/ remuneration included in the quoted price(s) for such agents/ representatives in India.
- 2.1.3 Confirmation of the Tenderer that the commission/ remuneration, if any, payable to his agents/ representatives in India, may be paid by BHEL in Indian Rupees only.
- 2.2 Tenderers of Indian Nationality shall furnish the following details in their offers:
- 2.2.1 The Bidder(s)/ Contractor(s) of Indian Nationality shall furnish the name and address of the foreign principals, if any, indicating their nationality as well as their status, i.e. whether manufacturer or agents of manufacturer holding the Letter of Authority of the Principal specifically authorizing the agent to make an offer in India in response to tender either directly or through the agents/ representatives.
- 2.2.2 The amount of commission/ remuneration included in the price (s) quoted by the Tenderer for himself.
- 2.2.3 Confirmation of the foreign principals of the Tenderer that the commission/ remuneration, if any, reserved for the Tenderer in the quoted price(s), may be paid by BHEL in India in equivalent Indian Rupees on satisfactory completion of the Project or supplies of Stores and Spares in case of operation items.
- 2.3 In either case, in the event of contract materializing, the terms of payment will provide for payment of the commission/ remuneration, if any payable to the agents/ representatives in India in Indian Rupees on expiry of 90 days after the discharge of the obligations under the contract.
- 2.4 Failure to furnish correct and detailed information as called for in paragraph 2.0 above will render the concerned tender liable to rejection or in the event of a contract materializing, the same liable to termination by BHEL. Besides this there would be a penalty of banning business dealings with BHEL or damage or payment of a named sum.

---X---

## Annexure-B

This format is applicable only to Indian Suppliers/ Agents supplying indigenous portion of Foreign Purchases.

\* In all other cases, extant guidelines of SEARP, 2010 are to be followed.

SEARP (SRF) Clause No	Detail
	<b>Name &amp; address of the firm</b>
1.0	<b>Products/ Systems / Services being considered for</b>
2.0	<b>General Information</b>
2.2	Name of Chief Executive
2.3	Details of authorized signatory
3.0	<b>Ownership Information</b>
3.1	Type of firm
3.2	Nature of Business <ul style="list-style-type: none"> <li>• Attach <b>authorization letter</b> and <b>agency agreement</b> from Principal ( from whom capital equipment is procured)</li> <li>• Attach copy of declaration from Foreign Principal for <b>total guarantee/ warranty of indigenous supplies</b></li> </ul>
3.3	Year of establishment
3.4	Year of commencement of business
4.0	<b>Registration particulars</b>
4.1	Permanent Account No.
4.2 / 4.3	Sales Tax / TIN no
4.6	Service tax no. (in case of E&C)
5.0	<b>Organisational strength</b>
6.0	<b>Other particulars</b>
6.1	If the company is already registered with other units
6.2	Directors/ Partners, if related to any BHEL Employee
6.9	If any Ex BHEL Personnel employed by the Company
6.12	Details of pending legal issues with BHEL
6.13	Bank Account information
9.0	<b>Financial information</b>
9.6	Sales/ Turnover details of last 3 years (or from the date of incorporation whichever is less )

---x---

AUTHORISATION LETTER  
FOR E-PAYMENT/ELECTRONIC FUNDS TRANSFER (EFT/RTGS)  
PLEASE FILL UP THE FORM IN CAPITAL LETTERS ONLY

TYPE OF REQUEST (Tick One)  CREATE  CHANGE

BHEL Vendor/ Supplier Code	
Company's Name	
Address	
City	
Pincode	
State	
Contact Person(S)	
Telephone NO	
FAX No	
e mail Id	
1. Bank Name	
2. Bank Address	
3. Bank Telephone No.	
4. Bank Account No	
5. Account Type	
6. Bank's Branch Code	
7. Bank Swift Code	
(applicable to EFT only)	
8. Enclose blank cancelled cheque	<input type="checkbox"/>

DECLARATION

- I as representative/Owner of the above named company, hereby authorize BHEL, CFFP, Ranipur, Haridwar to electronically make payments to the designated bank account hereby certify that the particulars given above are true, complete and correct.
- If the transaction is delayed or not effected at all for reasons of incomplete or incorrect information, would not hold BHEL/transferring Bank responsible.
- This authority remains in full force until BHEL, CFFP, Ranipur, Haridwar receives & acknowledge written notification requesting a change or cancellation.
- I have read the contents of the covering letter and agree to discharge the responsibility expected of me as a participant under E-payment/EFT/RTGS.

Date:  
Authorized Signatory  
Designation  
Company Seal

Verification By Bank

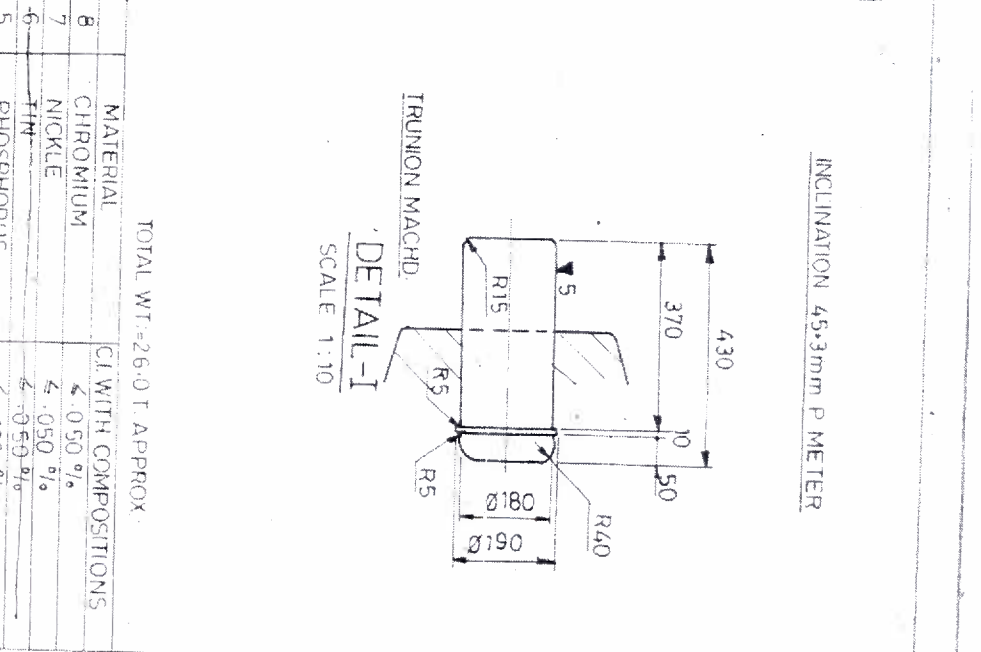
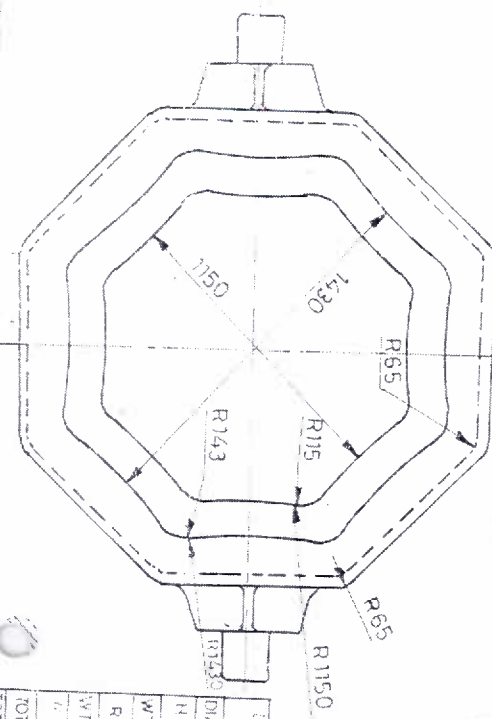
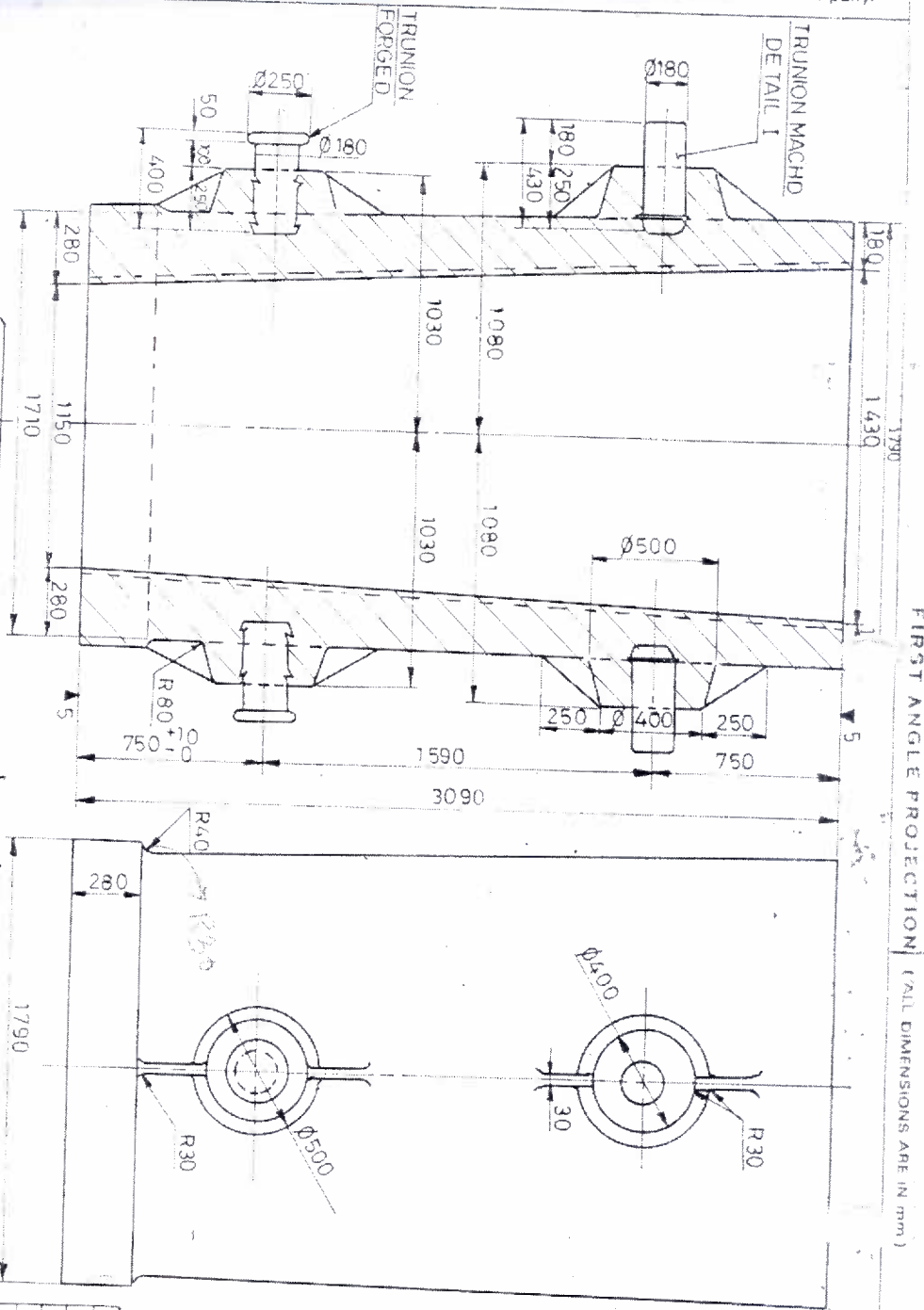

Note: Composition requirement as per SFL technology -  
 Ti = 0.005% max  
 Arsenic = 0.005% max  
 Lead = 0.005% max

DIMENSIONS	
HT. OF BODY	1687.640
HT. OF BODY MIN	1687.240
WT. OF INGOT TONNE	1300.990
RATIO H/D	1.20
WT. OF BOT. TONNE	1.20
HT. OF HOT TOP TONNE	3.10
TOTAL WT. TONNE	23.397448
TOTAL HT. mm	3098

DATA  
 DEPT. F.E.  
 CORP. 13008R  
 SCALE 1:20 (1:10)  
 WEIGHT (KG) 26.0 T

BHARAT HEAVY ELECTRICALS LTD.	
REF. CL. ORG. NO. 272 FOR 13008R	INGOT MOULD
UNIT: C.F.P., HARDWAR	
DEPT. F.E.	CORP. 13008R
SCALE 1:20 (1:10)	WEIGHT (KG) 26.0 T
DIMENSIONS to be Controlled Within Limits as Shown	
Machining Tolerance + 25 (unless otherwise)	
Show: Plan Machining Tolerance +	
CARD CODE	02-148
DRAWING NO.	151085V.1
APPROVED	DATE
DRAWN: AEDD (BJ)	DATE
CHECKED: [Signature]	DATE: 23-3-82
SHEET NO. 01	NO. OF SHEETS 01

MATERIAL	CL WITH COMPOSITIONS
8 CHROMIUM	< 0.50%
7 NICKLE	< 0.50%
6 TiH	< 0.50%
5 PHOSPHORUS	< 0.120%
4 SULPHUR	< 0.050%
3 MANGANESE	0.4 TO 0.5%
2 SILICON	1.4 TO 2.0%
1 TOTAL CARBON	3.6 TO 4.0%

TOTAL WT. = 26.0 T APPROX.

The information on this document is the property of BHARAT HEAVY ELECTRICALS LIMITED. It must not be used directly or indirectly in anyway detrimental to the interest of the company.

Inventory No. 23231010  
 Date: \_\_\_\_\_  
 Ref. Org. No. \_\_\_\_\_

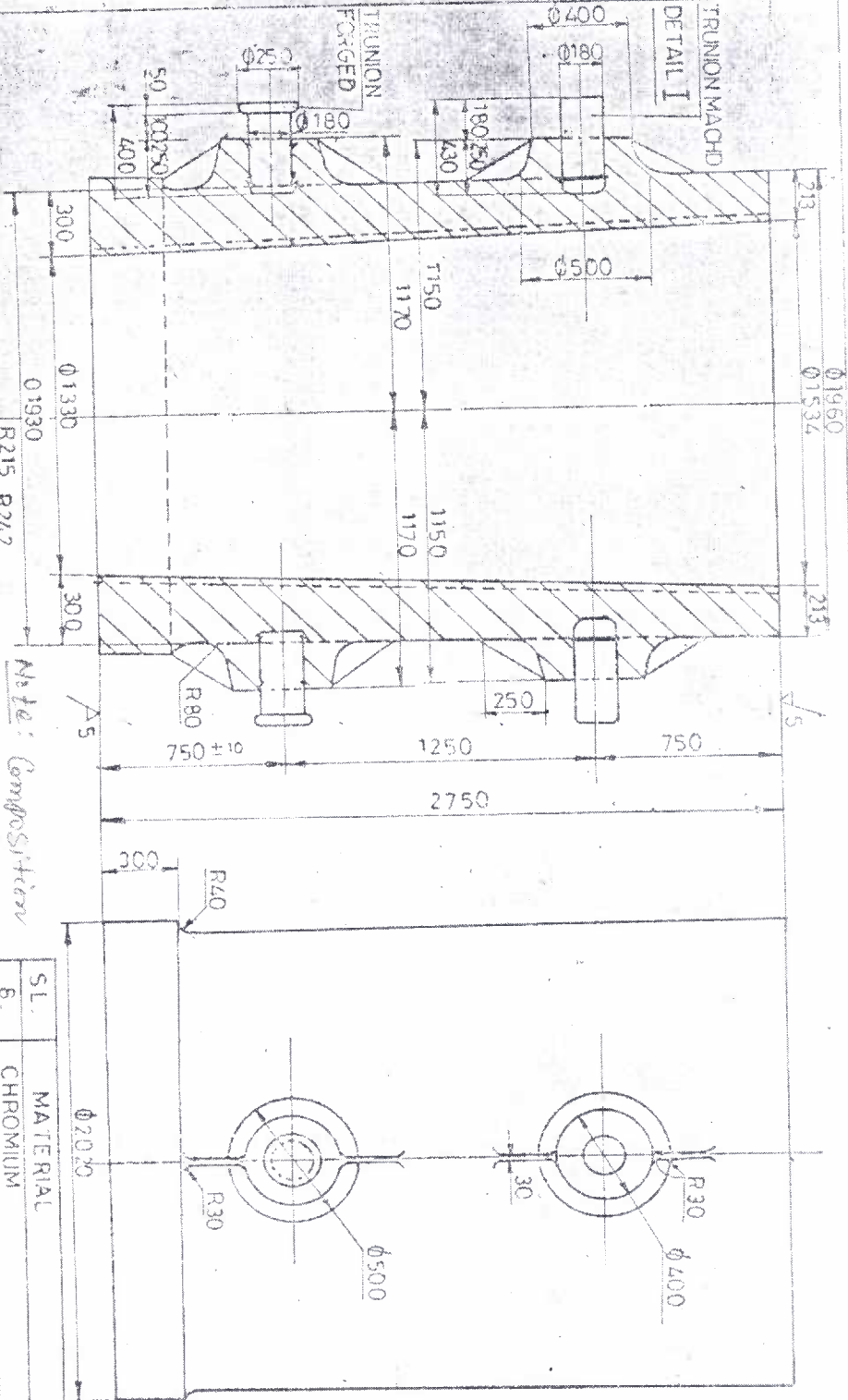
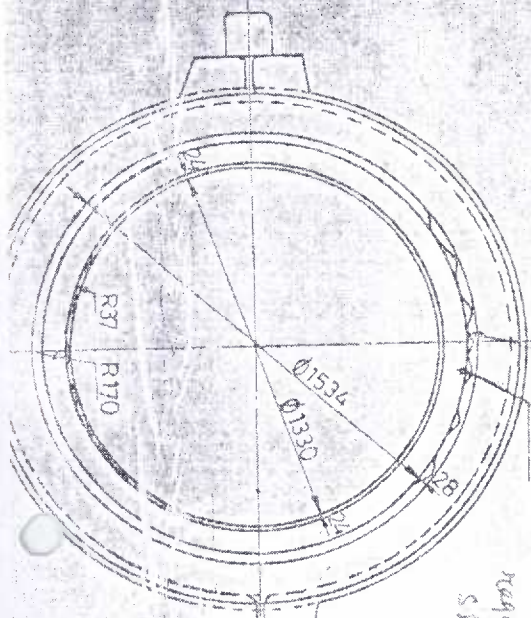

*Note: Composition requirement as per SLL Technology*  
 Tin = 0.005% Max  
 Arsenic = 0.005% Max  
 Lead = 0.0003% Max

SL.	MATERIAL	COMPOSITION OF MATERIAL REF/CL/BHEL/53	C.I. WITH COMPOSITIONS.
1.	TOTAL CARBON	3.6 TO 4.0%	
2.	SILICON	1.4 TO 2.0%	
3.	MANGANESE	0.4 TO 0.5%	
4.	SULPHUR	< 0.05%	
5.	PHOSPHORUS	< 0.12%	
6.	TIN	< 0.005%	
7.	NICKLE	< 0.005%	
8.	CHROMIUM	< 0.05%	

REF: CL DRG NO 349 FOR 1400<sup>2</sup>R INGOT MOULD

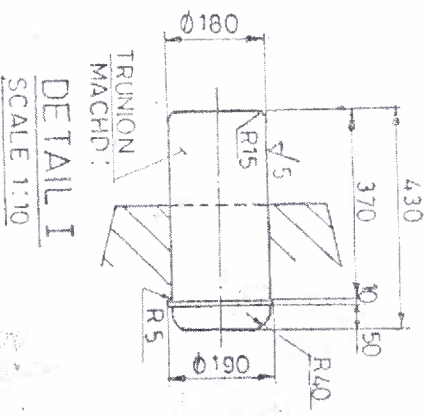

DATA *Scale 1:2*

DIMENSIONAL UNIT	M.M.S.U.T
UNIT OF BODY DIM	MM/INCH
UNIT OF BODY DIM	MM/INCH
WT OF INGOT TONE	1360/31.00
WT OF SOLID TON	1196/1.74
WT OF SOLID TON	1.20
WT OF HOT TON	390/6.00
TOTAL WT TONNE	2870/38.70

**BHARAT HEAVY ELECTRICALS LTD.**  
 UNIT: C.E.P. HARDWAR.

DEPT: \_\_\_\_\_  
 SCALE: 1:20, 1:10, 27:01  
 WEIGHT (KG): 2701

REF TO ASSY DRG: 23231010

CHECKED: \_\_\_\_\_  
 DATE: \_\_\_\_\_

DRAWING NO: 02-149