

DRAWING NO. 1-57-466-00173

ALL DIMENSIONS ARE IN MILLIMETRES

TYPE & SIZE OF WELD	TYPE & SIZE OF ELECT.
4	E-7018

25/

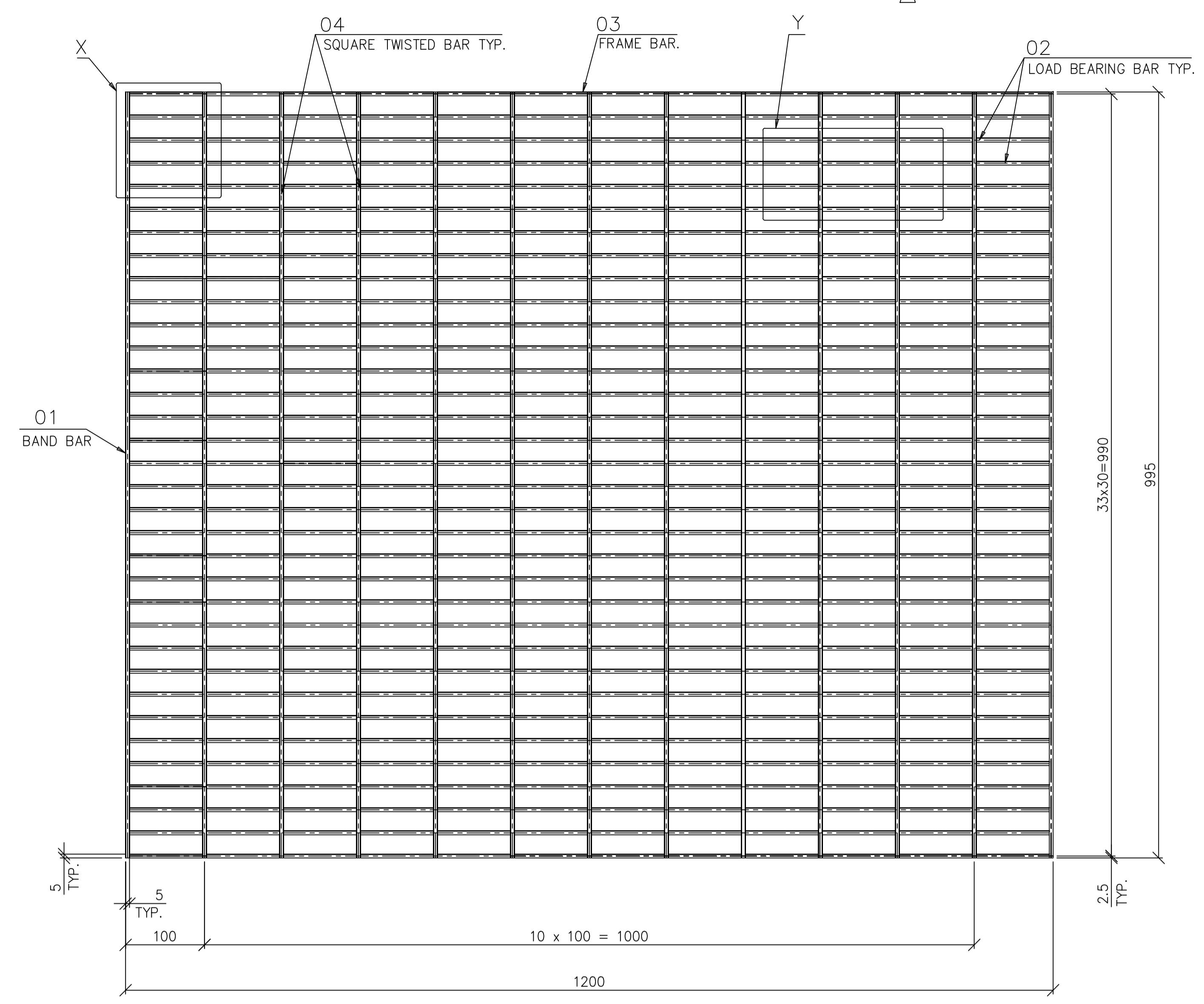

NOTES:

- FLOOR GRATINGS ARE TO BE GALVANISED AFTER BLAST CLEANING TO Sa 2-1/2 FINISH, BY HOT DIP PROCESS, MINIMUM AVERAGE WEIGHT OF ZINC COATING SHALL BE 610 GRAMS PER SQ. METER.
- STRUCTURAL STEEL CONFORMING TO SPECIFICATION IS 2062 Gr.A ONLY ARE TO BE USED.
- GALVANISING TO BE DONE AFTER ALL WORKS ARE COMPLETED.
- ALL SCRATCHED SURFACES AND AREAS DAMAGED BY SITE WELDING SHALL RECEIVE ATLEAST TWO COATS OF COLD GALVANISING USING ZINC RICH PRIMER /PAINTS. THE TOTAL DRY FILM THICKNESS OF SUCH TOUCH UP COLD GALVANISING SHALL NOT BE LESS THAN 150 MICRONS.
- DESIGN LIVE LOAD FOR FLOOR GRILL = 1000 KG/SQ.M
- MAXIMUM DEFLECTION ALLOWED "LENGTH/325" MM UNDER UDL OF 1000 KG/SM
- ALL GRATING MEMBERS ARE TO BE ELECTROFORGED EXCEPT BAND BARS.
- WEIGHT OF FLOOR GRILL INDICATED DOES NOT INCLUDE WEIGHT OF WELD.
- FRAME BAR WELDING : ALL FOUR CORNERS TO BE FULL WELDED TO BAND BARS AND EVERY FIFTH LOAD BEARING BAR TO BE WELDED TO BAND BAR BY MANAL WELDING FULL DEPTH AT BOTH ENDS FROM ONE SIDE.
- GRATINGS ARE FOR OUT DOOR APPLICATION.
- TOLERANCE ON THICKNESS SHALL BE AS PER IS1852
- OUT OF FLATNESS AT THE TOP & BOTTOM SURFACE IS PERMITTED AS 2MM
- DIAGONAL VARIATION ALLOWED 2MM

02

PACKING:

16 NUMBERS & PART THEREOF SHALL BE PACKED WITH SUITABLE PACKING MATERIAL AS BUNDLES FOR EASY HANDLING, LOADING & UNLOADING PURPOSE.

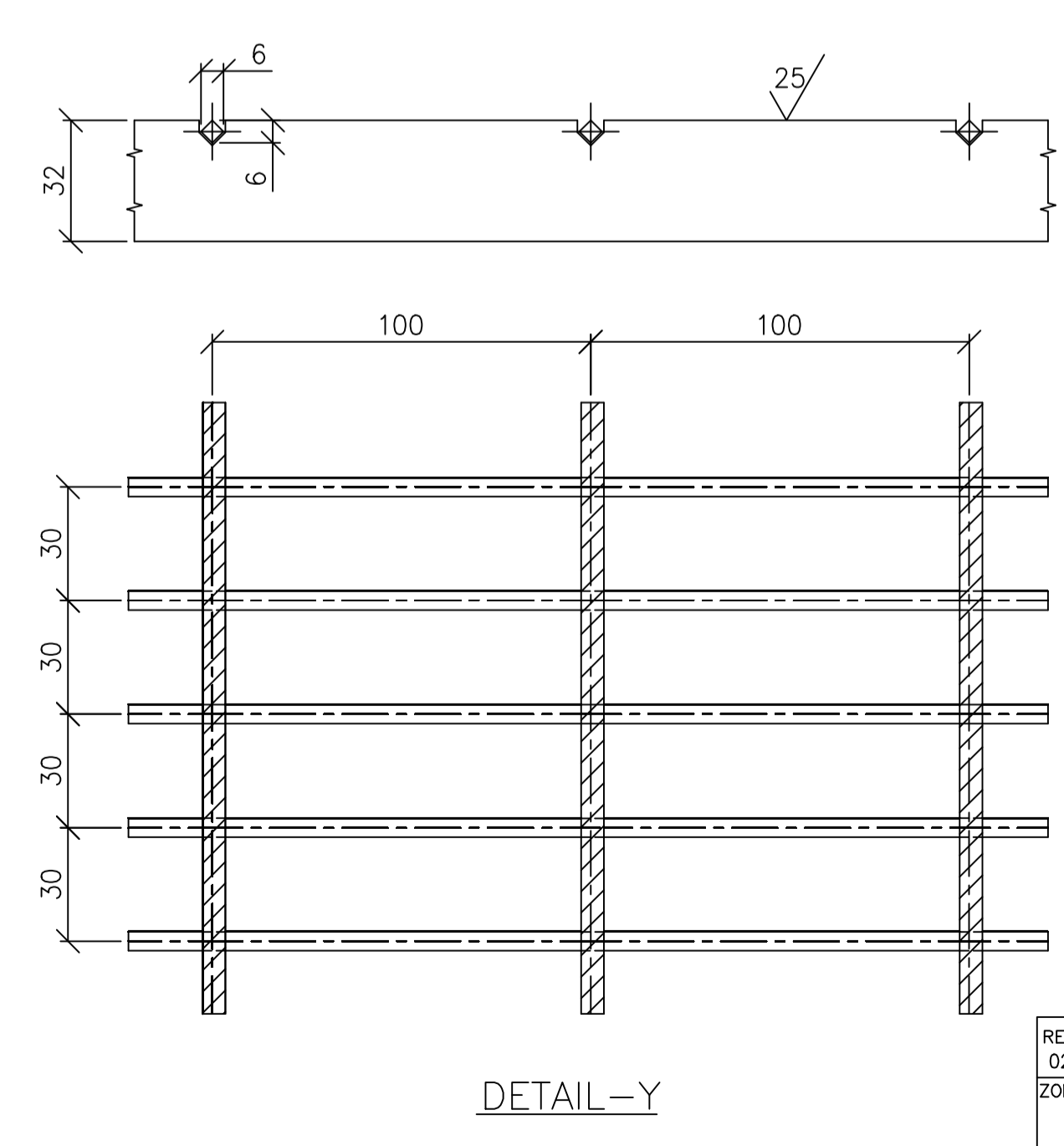
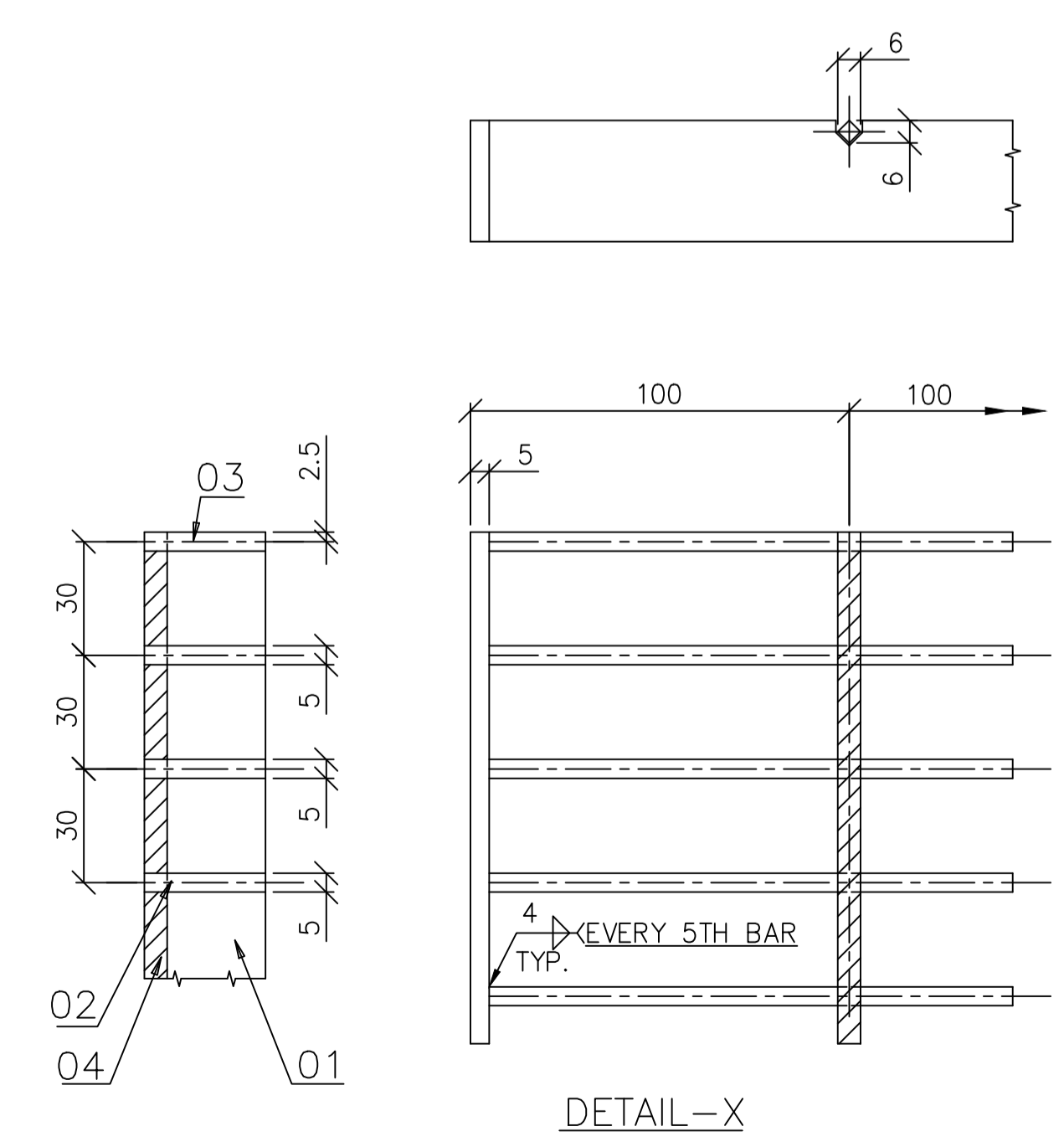

ITEM NO.	DESCRIPTION	STD.	DRAWING NO.	ITEM NO. VAR. NO.	MATL. CODE	MATL. SPEC	A	UNIT	UNIT WT.	QUANTITY	ZONE
01	04 TWISTED SQ. BAR 6mm (DIAGONAL)X 995				IS 1786				0.280	11	
01	03 PL 5x32x1190				150110290000				1.500	2	
01	02 PL 5x32x1190				IS 2062 Gr.A				1.500	2	
01	01 PL 5x32x995				150110290000				1.250	2	
					IS 2062 Gr.A				1.250	2	

CAUTION: The information on this document is the property of BHARAT HEAVY ELECTRICALS LTD. and should not be used directly or indirectly in any way detrimental to the interest of the company.

REV 02	DATE 9.4.11	ALTERED S.KALAI	CHECKED V.KESAVAN	REV 01	DATE 12/9/09	ALTERED D.K	CHECKED V.K
ZONE	PACKING NOTE ADDED		ZONE	NOTES ADDED			

DEPT CD 877	GRADE OF UNTOL DIM PR:QA:500	SCALE N.T.S	WEIGHT (KG) 56.580	REF. TO ASSY/OLD DRG. 1-35-811-02525	ITEM NO. OF ITEMS
TITLE FLOOR GRILL-32x995x1200 (ELECTRO-FORGE-GALV-6SQ-TWST) M.C : 961453500000	CARD CODE U 01	DRAWING NO. 1-57-466-00173	REV 02		