

**Project : NEYVELI NEW THERMAL POWER PROJECT (NNTPP)  
2 X 500 MW**

Specification : GDRS:022/Rev00



**TECHNICAL SPECIFICATION**

for

**DAMPERS - HOT AIR TO BURNER COMPARTMENTS**

CUSTOMER : NEYVELI LIGNITE CORPORATION

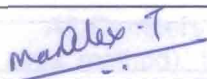

Prepared	Checked	Approved
		
M. Suresh / Manu Alex Thomas Engineer-EDC/G&D	V. KESAVAN Sr. Manager-EDC/G&D	D. ASHWIN DHINAKAR DGM-EDC/G&D
Rev.00		

PART CONTENTS LIST

SI No	Particulars	Page No
1	Information on Plant Site	3
2	Application of Dampers	3
3	Scope of supply	3
4	Split/Modular design	4
5	Construction Details	4
6	Material of Construction	6
7	Seal Air system	7
8	Actuator System for Damper	7
9	Painting Requirements	7
10	Testing	8
11	Packing for dispatch	8
12	Assistance for commissioning	8
13	Spares	8
14	Special Tools	8
15	Qualification Requirement (Offer Acceptance Criteria)	8
16	Documents	10
17	Responsibility	12

SI. No.	List of Enclosures:-
1	Electrical Actuator specification (TDA:STD:OCE:001/Rev02)
2	Data Sheet (DS 57683)
3	Checklist (CL 57683)
4	Proforma Invoice (PI 57683)

## 1.0 INFORMATION ON PLANT SITE

### 1.1 **Location:**

The plant is situated in Neyveli, Tamil Nadu State in India. Neyveli is 62 kilometers (39 mi) inland from Bay of Bengal, west of Pondicherry and 197 kilometers (122 mi) south of Chennai. Height above mean sea level is 87m.

### 1.2 **Climate of Neyveli:**

The climatic data in vicinity of the site are as follows:

Temperature of outside air:

Absolute minimal temperature, ° C : +15

Absolute maximal temperature, ° C : +45

## 2.0 Application of Dampers:

Isolation of Burner Compartments. Refer Damper Data Sheet.

## 3.0 Scope of supply:

Design, Manufacture, Testing, Painting & Packing for shipment and commissioning supervision.

- (i) Damper Assembly- Hot Air to Burner Compartments with **mating flanges (and connecting bolts)** on both sides (upstream and downstream) are in vendor's scope of supply. (The damper details & quantity required are mentioned in Damper Data Sheet).
- (ii) Electrical Actuators (2 Nos. per damper).
- (iii) Seal air system: Not applicable for dampers for this project.
- (iv) All Dampers shall have a reasonable Sealing Efficiency of minimum **99.5%** (by surface area method). Inspection Reports should be submitted to prove achievement. Leak Tightness test (On-flow, Type test) is not applicable.
- (v) Commissioning Supervision support.

For more details refer Damper Data Sheet.

(vi) Spares ( will be covered separately but vendor to quote with breakup price for the following- **Refer Clause No: 13.0. Spares.**

#### 4.0 Split / modular design:

Damper size being small, damper has to be manufactured and transported as a single and complete assembly. Vendor has to specify the method of construction & mounting details during the offer. However, the actuators may be sent loose and mounted at site. The frame of the damper should hold the mounting bracket for the actuator and is to be supplied by the vendor.

#### 5.0 Construction Details :

The Damper Dimensions are mentioned and other details are mentioned in Data Sheet. The Damper shaft orientation is vertical.

Quantity required is: 24 Dampers per Steam Generator (each damper is having 2 electrical actuators). Construction details are mentioned in Data Sheet. There are 8 ducts entering into the furnace at each level across the circumference of the furnace. Each duct has this referred damper. There are 3 levels of ducts around the furnace per boiler (Total quantity = 8 x 3 = 24 Nos. per boiler).

In total, there are 48 Dampers for 2 Steam Generators of 500 MW each.

The sketch of location of damper is shown below for reference.

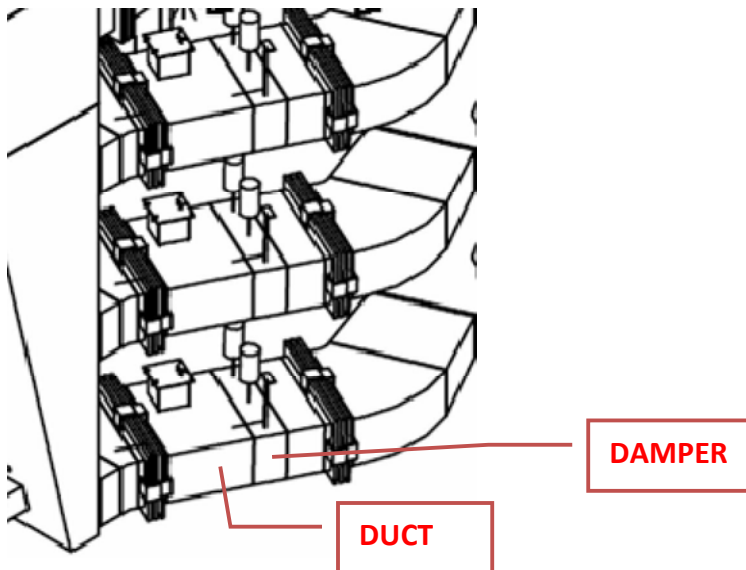

The Overall Damper size is 790mm in Vertical direction (Damper Inside) X 1790mm in Horizontal direction (Damper Inside).

This damper is having 3 partitions, of which 25% flow is through Left partition, 50% flow is through Middle partition & remaining 25% flow is through Right partition. The damper shafts are vertically aligned. The Damper Flaps in Left & Right partition (each 25% flow) should Open/ Close together (both will either be in open condition (or) both will be in closed condition simultaneously). The Left & Right Damper Flaps are Operated by a Single Electric Actuator

(open-close function). The vendor has to design linkage rod/levers for simultaneous operation suitably.

The Middle flap is operated by another Electric Actuator (open-close function). Electric signals for Open/ Close to each of the actuators will be given independent of the other. Hence, it may be possible that both the sub-dampers may be simultaneously open or one damper open and the other is closed.

Hence, there are 2 Electric actuators (open-close) per Damper. There should not be any interference/ fouling between actuator, linkage assemblies, mounting brackets etc of the 3 sub damper assemblies.

The Upstream side of this Damper will have only 1 duct of size **(790mm in Vertical direction (Damper Inside) X 1790mm in Horizontal direction (Damper Inside))**. Whereas, the downstream side of this Damper will have 3 compartments leading up to burner. Thickness of the duct is 5 mm. **A Cooling Position is necessary to protect the burner equipment. Mechanical end stop (adjustable) have to be used. Details are mentioned below:**

**Sense and purpose of an adjustable end-stop:** With this technically simple mechanism the damper movement can be limited in that way that it is not possible to close the damper 100%. The damper drive will in fact stop if the presetted position is reached also in case that the drive will not stop in correct position. If the damper would close 100% the burners will be damaged due missing cooling air passing these dampers.

The provision of end stop adjustments in open & close positions with graduated position indicators should enable local adjustment between 0 to 5 degrees in open position of damper (i.e., damper can be between 85 to 90 degrees open), and for close position to be adjustable between 0 and 5 degrees. The above adjustable end stops should be available for both the drive levers (levers of both actuators).

**Locking devices:**

Manual locking devices (adjustable) are required at open and close positions for both drive levers. The locking devices shall permit locking anywhere between 0 to 5 degrees in open position of damper (i.e., damper can be between 85 to 90 degrees open), and for close position to be locked anywhere between 0 and 5 degrees. The above adjustable locking devices should be available for both the drive levers (levers of both actuators).

The above end stops and locking devices should be possible to be adjusted at site depending on site condition by operator.

**The levers, end stop adjustments, locking devices, linkage rods and graduated position indicators should come at the top side of the dampers (where the 2 drives are located).**

The GA drawing submitted along with Technical Offer should clearly show the vertical shaft, bearing arrangement, drive arrangement, graduated position indicator, damper linkages, separate adjustable end stops for both the drive levers and adjustable locking device for both the drives. **Without the above details, the Technical Offer will be treated as incomplete and rejected.**

Please refer Data Sheet and sketch mentioned in Data Sheet for more details.

**5.1 Casing:-** Casing shall be fabricated to suit the specified inside dimensions in Data Sheet. Lifting lugs shall be provided for handling. The casing shall be suitably stiffened. The Name plate details with Purchase order number, Vendor name, Address & email ID shall be fastened visibly on drive side of the casing. A Blade position indicator shall be mounted on the drive side of casing. Flow direction should be clearly indicated by fixing a painted S.S. arrow on both sides of each Damper to clearly distinguish upstream and downstream sides of damper.

**5.2 Locking device:** Refer clause 5.0 above.

**5.3 Blades:** - Vendor has to specify the blade design & blade material in their offer.

**5.4 Shaft:** - Vendor has to specify the shaft design, material specification and provision for expansion of the blades. Shaft position is Vertical.

**5.5 Linkage Mechanism:-** Vendor has to specify.

**5.6 Stuffing Boxes:** Special external stuffing boxes are to be installed at top and bottom side of the damper casing for tight sealing of the passage of the trunnion through the damper casing. The stuffing box packing shall not deflect during blade movement, or due to thermal expansion, and shall remain gas tight. Vendor has to specify their design.

**5.7 Bearings:-** The bearings design offered should be suitable for the intended vertical axis shafts & the operating parameters specified in Data Sheet and designed to be in continuous service. Vendor to confirm that design of damper is suitable for the intended service. Suitable bearing shall be provided for the shaft (maintenance-free spherical roller bearing) for supporting the trunnion. Bearings, shafts and blades are to be designed taking care of thermal expansion at 370 deg C (design temperature) continuous exposure and it should operate freely without jamming even under arduous conditions.

#### **5.8 Sealing System:**

Sealing arrangements shall ensure **99.5%** sealing efficiency (by surface area method) without seal air. If above minimum efficiency cannot be guaranteed, then suitable seals shall be installed on the periphery of the damper blades. If above sealing efficiency is guaranteed without Seals, then these seals are not required. Seals shall have minimum service life of three years before replacement. The seal fixing arrangement for blade to blade, blade to frame and jamb seal shall be clearly specified in the drawing. The seal and mounting design shall have the facility for easy replacement of seals during maintenance.

**5.9 Site Assembly scope :** Not Applicable for this project.

#### **6.0 Material of Construction:-**

The Adjoining duct thickness is mentioned in Data Sheet.

The materials selected for damper structure and sub-components should be clearly specified in the offer. The material selected shall be suitable for continuous exposure of flow medium at 370 deg C (design temperature). The flow medium is Hot Air (with traces of ash carryover from Air Pre-Heater) with a velocity of 16 m/sec.

**Damper frame:-**

External parts: IS2062 (or) S235JR (or) better material.

Medium exposed parts: P265GH (or) better material.

(The material should withstand the operating conditions mentioned in Data Sheet).

**Damper Blade:-** P265GH (or) better material. (The material should withstand the operating conditions mentioned in Data Sheet).

**Damper shafts:** – SA479 Type 304 (or) better material. (The material should withstand the operating conditions mentioned in Data Sheet).

**Seals:-** Vendor to specify. (Also refer Clause No: 5.8).

**Lever/Link Rod:** Vendor to specify.

**7.0 Seal Air system**

Not applicable for these Dampers in this project.

**8.0 Actuator System for Damper:** Type of actuator- **Electrical (Motorized) Open-Close.**

The electrical actuators are to be mounted on top of the vertical shaft of the dampers as indicated in Data Sheet.

**8.1 Electrical Actuator:**

Electrical (Motorized) Actuator with Secondary Gear box and splined bush - worm gear & self locking ).

Electric actuator with manual hand operated wheel for manual operation. The force required to operate manually shall be within 35kgf at the wheel rim. Vendor shall furnish actuator details like make, model, KW rating, output RPM, sizing torque, run torque, stall torque. Actuator should be suitable for **3 phase power supply , 50 Hz & 415 V AC**. The actuator shall have **Non- integral starter**, limit switches and Positional transmitters ( Inductive type ). **The Protection class should be IP-67. (Refer enclosed specification, TDA:STD:OCE:001/Rev02).**

**8.2 Limit switch requirement and feedback mechanism to DCS:**

Sufficient number of integral limit switch shall be provided in the actuator as below:

i) One pair of limit switches at the open and close positions for each actuator.

**9.0 Painting requirements :**

Internal parts: Sand Blasting to SA 2.5, two coats of zinc ethyl silicate, dft. approx. 40 micron.

External (insulated parts): Sand Blasting to SA 2.5, two coats of zinc ethyl silicate, dft. approx. 40 micron.

External (non-insulated parts): Sand Blasting to SA 2.5, two coats of zinc ethyl silicate, dft. approx. 40 micron.

**Compatible Finish Painting** also to be done over the zinc ethyl silicate coating.

Painting is not applicable for stainless steel parts.

**10.0 Testing:**

Leak Tightness test (On-flow, Type test) is Not Applicable. However, Dampers shall have a reasonable Sealing Efficiency of minimum **99.5%** (by surface area method). Inspection Reports to be submitted for clearance.

**11.0 Packing for dispatch:**

The dampers and related components shall be directly dispatched from vendor's works to site. Packing shall be suitably selected. For site details, refer Clause no: 1.1.

**Vendor to indicate price break up for erection Packing charges / Shipping charges / any extra charges.**

Overall Transportation Limitations for Indian Roads ( for guidance )

Width of road transport = 5500mm maximum

Height of the consignment = 5000 mm maximum

Length of consignment = 20000 mm

Weight of the consignment= 40000 kg

Vendor shall submit shipping bill of material with packages, identified with overall size, quantity and weight. Overall dimensions shall be as per transport limitations furnished above.

**12.0 Assistance for Commissioning :**

The Bidder shall quote separate breakup price (lump sum) for supervision support to be rendered during commissioning of the damper at site for first unit. The vendor has to offer supervision support during Commissioning for 2 days at Neyveli site and is to be indicated in Sl. No: 3 of PI-57683. Payment will be made on certification by site engineer on satisfactory completion of support. BHEL will inform the vendor sufficiently in advance when the supervision of commissioning is required at site. Vendor will have to make their own travel to site, boarding & lodging arrangement at site/ near site including local travel during this period.

**13.0 Spares :**

The Bidder shall offer for the following **separately for each item.**

- a. Commissioning spares – Quantity with per unit rate, if applicable.
- b. Electrical Actuators - 1 no. of Electrical Actuator for damper's middle flap and 1 no. of Electrical Actuator for damper's extreme flaps for each type/model/make/rating of electrical actuator.

**14.0 Special Tools :**

The dampers shall be designed to be assembled, disassembled and maintained with standard hand tools. However, if at all the vendor desires special tools are required, the same has to be supplied along with the damper. List of special tools if applicable is to be brought out clearly in "SCOPE OF SUPPLY".

**15.0 Qualification Requirement (Offer Acceptance Criteria) :**

**a)** The bidder to qualify should have engineered and supplied (manufactured by themselves or through their outsourced manufacturers or through their technology licensee) an open/close electrical operated damper having the following technical features:

- i) One Damper frame consisting of 2 electrical drives (actuators).

ii) The Damper shafts are in vertical axis (when installed in duct and viewed along the direction of flow in duct).

The damper supplied by the bidder having the above 2 features should have been erected and completed at least 1 year of satisfactory operation as on date of tender opening. The bidder shall provide their customer reference details for the above referred damper supplied by them. Details of name of project, date of commissioning to be furnished. Bidder shall also submit a general arrangement drawing for the above reference project damper showing clearly the bidder/licensee/licensor name in the title block as applicable. The drawing should clearly prove that the reference damper has the above 2 technical features specified.

**b)** In case of licensee is the bidder, the licensee shall furnish a certificate from the qualified licensor meeting the above technical requirements specified in (a) above, that the bidder is authorized to quote for this project and they will provide the engineering support to enable the licensee to complete all deliverables indicated in scope of supply Clause 3.0 & 12.0. Also the reference details and GA drawing of the supplies made by the licensor for (a) above shall be enclosed. Non submission of details and back up documents specified in (a) and in the case of a licensee (a) and (b) above will lead to rejection of bidders offer and the same will not be considered for further evaluation.

Deviations if any to BHEL Specification shall be clearly brought out explaining the technical reasons against clause nos. Failure to do so implies that vendor complies to the Specification requirement.

**16.0 DOCUMENTS:**

Vendor shall submit the following documents and drawings in English

**16.1 Documents to be submitted along with Offer.**

Sl.no:	DOCUMENTS	Vendor Acceptance comments/
1	(i) Comments/deviation for the Specification No. GDRS:022/00 & related enclosures (ii) Filled up Data sheet for Damper: DS-57683 (iii) Filled up Proforma Invoice ( Un-Priced Price Bid) : PI-57683 (iv) Filled up Checklist : CL-57683 (v) Filled up Electrical Actuator Data Sheet	
2	General arrangement drawing with dimensions showing location of Accessories like Actuators, BOM, Weight, Flaps and linkage, Bearing, Shaft and damper orientation and End Stop adjustments. (Refer Clause No. 5.0)	
3	Vendor quality plan for review	
4	Recommended spares list for commissioning & Three year operations	
5	Reference list & documents/drawing for similar type of damper as indicated in Clause No: 15.0 (a) & (b)– to prove Qualification Requirement	
6	Vendor confirmation for all documents submission in 16.2,16.3 & 16.4 for approval as specified after placement of purchase order.	
7	Draft Erection & Commissioning Procedure applicable for the offered design and scope of supply.	

**16.2 Vendor shall submit the following Documents for BHEL approval within 30 days after placing Purchase Order. Only after BHEL Approval, vendor can commence manufacturing activity.**

Sl. No	Documents	No. of Copies required	Vendor acceptance comments / deviation
1	Revised Quality plan(if any)	1	
2	Final Damper Datasheet	1	
3	Finalized details with make & model nos. of electrical actuators in Actuator Data Sheet	1	
4	G.A Dimensions and Mounting details of Damper and its Accessories, End to end dimensions of Damper with mating flanges. (Refer Clause No. 5.0)	1	

**16.3 Documents to be submitted before dispatch**

Sl. No.	Documents	No. of Copies required	Vendor acceptance comments / deviation
1	Complete inspection / test records of Dampers including Sealing Efficiency (Surface Area) Test Reports	2	
2	Raw material Test Certificates	2	
3	Packing drawing & specification	2	
4	Erection drawing & Erection manual (in English for Damper, Actuator)	3	
5	Protection / Interlocks, Operating Procedures / Trouble shooting & Maintenance etc.	3	

**16.4 Documents to be submitted along with Dispatch**

Sl. No.	Documents	No. of Copies required	Vendor acceptance comments / deviation
1	Shipping list / supply schedule	3	
2	List of spares dispatched	3	
3	O&M manual (in English for Damper, Actuators)	3	

**17.0 RESPONSIBILITY:**

The extent of supply stated herein is not necessarily exhaustive and shall not relieve the supplier from his responsibilities to provide goods & services necessary to satisfy the purchaser's performance criteria & required life, to be complete for installation & to be fit for purpose, safe, reliable, easily maintained and efficient in operation.

Bidder shall make all possible efforts to comply strictly with the requirements of this specification and other specifications/ attachments to inquiry/ order.

**In general, deviations are not acceptable.** In case, deviations are considered essential by the Bidder (after exhausting all possible efforts), these shall be separately listed in the Bidder's proposal titled as "List of Deviations/ Exceptions to the Enquiry Document". Deviation shall be listed separately for each document with cross reference to Page No./ Para etc. of the respective document supported with proper reasons for the deviation for purchaser's consideration. Any deviation, not listed under the above section, even if reflected in any other portion of the proposal, shall not be considered applicable. No deviation or exception shall be permitted without the written approval of the purchaser. In case the Bidder considers requirement of additional instrumentation, controls, safety devices and any other accessories/ auxiliaries essential for safe and satisfactory operation of the equipment, he shall recommend the same along with reasons in a separate section along with his proposal and include the same in his scope of supply.



BHARAT HEAVY ELECTRICALS LIMITED  
BOILER AUXILIARIES PLANT  
ELECTRICAL, CONTROLS AND INSTRUMENTATION  
RANIPET - 632 406.

TDA:STD:OCE:001  
REV. 02  
SHEET 1 OF 13

**SPECIFICATION**  
**FOR**  
**ELECTRIC DAMPER ACTUATORS**  
**(OPEN/CLOSE TYPE)**

**NOTE: Electrical Actuators for Neyveli project shall be of Protection Class: IP-67 without Integral Starter.**

REV. NO.	DATE	DESCRIPTION	PREPARED	REVIEWED	APPROVED
00	15.02.2006	Prepared inline with C&I/FB/ BHEL Trichy specation for Electric Actuator O/C Spec no. CI:O/C: STD:DA86/ REV.00	-sd-	-sd-	-sd-
01	12.11.2009	i. Cl.Nos.1.3, 1.4, 2.10 & 3.10 are corrected.	P.Muthukumar	S.Rangarajan	S.Rangarajan
02	27.05.2014	i. Cl.No.3.18 to3.23 are added.	K.Priyadharshini <i>Priyadharshini</i>	S.Rangarajan	S.Rangarajan
				<i>[Signature]</i>	<i>[Signature]</i>



**BHARAT HEAVY ELECTRICALS LIMITED**  
**BOILER AUXILIARIES PLANT**  
**ELECTRICAL, CONTROLS AND INSTRUMENTATION**  
**RANIPET - 632 406.**

**TDA:STD:OCE:001**  
**REV.02**  
**SHEET 2 OF 13**

### GUIDELINES FOR FURNISHING OFFERS

1. Offer for every actuator shall be as per - "ACTUATOR DATA SHEET" - enclosed. Along with offer filled up technical confirmations and informations shall be provided.
2. If there is a contradiction between this standard specification (TDA:STD:OCE:001:REV.01) and the customer specific requirements, customer specific requirements will be binding.
3. Colour of the actuator shall be as per purchaser's choice. Standard colour types available shall be furnished.
4. Type test, Routine test shall be conducted as per enclosures and same shall be confirmed in the offer.
5. ENCLOSURES:
  - Technical Confirmations : 4 Sheets.
  - Technical Information : 3 Sheets.
  - Test Requirements : 4 Sheets.
  - Actuator Data Sheet : 2 Sheets.
6. If any price involved for customer witnessing testing, the same shall be furnished.
7. Necessary sets (minimum 3) of catalogues, drawings, data & quality plan shall be furnished along with offers. Without these, offer will not be considered.
8. 25 sets of operation and instruction manuals, shall be furnished along with actuators. The basic pricing shall be include the same.
9. 3 sets of test certificates shall be furnished along with actuators. The basic pricing shall include the same.
10. Start - up, two years maintenance spares, and special tools required ( if any ) lists shall be furnished with price details.
5. Start - up, two years maintenance spares, and special tools required ( if any ) lists shall be furnished with price details.

**VENDOR SIGNATURE:**  
(with Seal)



**BHARAT HEAVY ELECTRICALS LIMITED**  
**BOILER AUXILIARIES PLANT**  
**ELECTRICAL, CONTROLS AND INSTRUMENTATION**  
**RANIPET - 632 406.**

**TDA:STD:OCE:001**  
**REV. 02**  
**SHEET 3 OF 13**

**TECHNICAL CONFIRMATIONS**

( VENDOR TO COMPLETELY FILL UP, AND FURNISH COPIES ALONG WITH OFFER )  
ELECTRICAL ACTUATORS FOR OPEN/CLOSE APPLICATION.

<b>SL.NO.</b>	<b>SPECIFICATION CONDITION</b>	<b>YES/NO</b>	<b>REMARKS</b>
1.0	<b><u>MOTOR</u></b>		
1.1	Motor suitable for 415V, 3Ø 50Hz, 3 wire supply .		
1.2	Motor conform to latest edition of IS 325 (or) BS 5000 Part 99.		
1.3	Motor painted with corrosion proof epoxy resin paint. (Refer Enquiry for paint Shade)		
1.4	Motor insulation minimum class - B (Non hygroscopic Insulation with Tropicalisation suitable as in 3.8). If higher insulation is provided, temperature rise shall be limited to class-B Insulation		
1.5	Motor rated for 15 minute duty ( For S2-15 min. )		
1.6	Motor suitable for Direct -ON-Line start.		
1.7	Starting current limited to 6 times full load current. ( Tolerance as per IS )		
1.8	Two earth terminals provided.		
1.9	Three thermostat one in each winding to be provided for motor winding protection.		
1.10	Motor winding connection brought to common terminal box.		
2.0	<b><u>ACTUATOR + SECONDARY GEAR BOX</u></b>		
2.1	Actuator + SY.GB can start at 80% rated voltage and run at 75% voltage for 5 minutes under loaded condition.		
2.2	Actuator + SY.GB can operate at specified run torque for the following conditions:		
2.2A	At ± 10% rated voltage (415V).		
2.2B	At ± 5% rated frequency (50Hz).		

**VENDOR SIGNATURE:**  
(with Seal)



**BHARAT HEAVY ELECTRICALS LIMITED**  
**BOILER AUXILIARIES PLANT**  
**ELECTRICAL, CONTROLS AND INSTRUMENTATION**  
RANIPET - 632 406.

TDA:STD:OCE:001  
REV. 02  
SHEET 4 OF 13

SL.NO.	SPECIFICATION CONDITION	YES/NO	REMARKS
2.2C	Combined variation of voltage and frequency 10% (absolute.)		
2.3	Actuator + SY.GB capable of meeting total turns indicated in "ACTUATOR DATA SHEET" and limit switches set accordingly.		
2.4	Actuator + SY. GB as a whole will meet minimum IP-55 protection and suitable for outdoor application.		
2.5	Actuator + SY.GB can meet specified continuous run torque at the duty specified in CL.1.4.		
2.6	Actuator + SY. GB shall meet all the conditions mentioned in "ACTUATOR DATA SHEET"		
2.7	Every actuator, especially SY. GB shall be self locking worm Gears.		
2.8	Minimum starting torque of whole actuator ( basic actuator + SY. GB ) for louver and gate shall be as per "ACTUATOR DATA SHEET" .		
2.9	Minimum run torque (15 min. Run torque for louver and 6 min. Run torque for gate) of actuator shall be as per "ACTUATOR DATA SHEET" .		
2.10	Actuator + SY. GB painted with corrosion proof epoxy resin paint.( Refer purchase enquiry for paint shade)		
2.11	Actuator + SY.GB output RPM shall be around 0.5 for louver and 1.9 for gates.		
2.12	Actuator and SY. GB shall be properly coupled and shall be despatched as a single unit.		
2.13	Actuator + SY. GB shall have proper seals to prevent leakage of oil to other compartments under any position of mounting.		
2.14	Secondary Gear Box continuous torque capacity shall be greater than or equal to starting torque of Actuator.		

**VENDOR SIGNATURE:**

(with Seal)



**BHARAT HEAVY ELECTRICALS LIMITED**  
**BOILER AUXILIARIES PLANT**  
**ELECTRICAL, CONTROLS AND INSTRUMENTATION**  
**RANIPET - 632 406.**

**TDA:STD:OCE:001**  
**REV. 02**  
**SHEET 5 OF 13**

SL.NO.	SPECIFICATION CONDITION	YES/NO	REMARKS
<b>3.0</b>	<b><u>ACCESSORIES</u></b>		
3.1	Name plate for torque switch calibration shall be provided with torque value in KGM.		
3.2	Actuator hand wheel de-clutches automatically upon power supply restoration.		
3.3	Counter clockwise rotation looking actuator driving end shall result in close. Also refer to "ACTUATOR DATA SHEET"		
3.4	Four limit switches, two torque switches self latching type mechanism rated for 240V, 5 A AC, 220V, 0.4 A DC, and each switch shall have 2 NO + 2 NC independent contacts.		
3.5	Actuator provided with mechanical position indicator for 0 To 100% adjustable.		
3.6	Position indicator provided with adjustable Gear sets & Charts.		
3.7	Actuator provided with space heater suitable for 240V AC, 1Ø, 50Hz in limit switch compartment.		
3.8	Actuator suitable for operation in Damp, Dusty, polluted atmosphere of 100% relative humidity and ambient temp. of -20°C to +50°C.		
3.9	Actuator control terminals suitable for 2 x 2.5 Sq.mm. stranded copper cable.		
3.10	Internal wiring to be done as per BHEL wiring diagram which is enclosed along with the purchase enquiry. Wiring diagram shall be pasted inside the TB compartment.		
3.11	Actuator shall be provided with two potentiometric type position transmitters suitable for 24V, AC/DC.		
3.12	Necessary number of cadmium coated fasteners (or) mounting bolts, nuts with spring washers properly fixed or screwed on secondary gear box shall be furnished with every actuator (to calculate length of fasteners, mounting plate thickness can be considered as 20 mm.). <b>THE FASTENERS SHALL BE IDENTIFIED SEPARATELY IN SHIPPING LIST / DELIVERY CHALAN.</b>		

**VENDOR SIGNATURE:**  
(with Seal)



**BHARAT HEAVY ELECTRICALS LIMITED BOILER  
AUXILIARIES PLANT**  
ELECTRICAL, CONTROLS AND INSTRUMENTATION  
RANIPET - 632406.

TDA:STD:OCE:001RE  
V. 02  
SHEET 6 OF 13

- | SL.NO | SPECIFICATION CONDITION | YES/NO | REMARKS |
|-------|-------------------------|--------|---------|
|-------|-------------------------|--------|---------|
- 3.13 Keyway shall be provided with every actuator (Dimension of keyway shall Be as per—ACTUATOR DATASHEET")
- 3.14 All louver ( 90° movement ) actuators shall have splined removable bush properly machined and Drilled to the dimensions mentioned in —ACTUATOR DATA SHEET" .
- 3.15 Actuator common terminal box shall be provided with 3 Nos. of 1 1/4" BSC and one No. of 1" BSC cable glands.
- 3.16 Actuator name plate shall have following minimum details:  
A. Standard Motor Details.  
B. Current proportional to 15 min. run Torque for louver and 6 min. run torque for gates.  
C. Tag No. as specified by BHEL.  
D. Direction of rotation for closing of load (Damper).  
E. Secondary Gear Box type.  
F. Angle of rotation 90° or 360° .  
G. Torque range of whole actuator.
- 3.17 Secondary gear box shall be provided with name plate.
- 3.18 The Bore and key way tolerance are given below.

Description	Main Dimension	Tolerance allowed
Bore Diameter	All	+0.05mm to -0.00 mm
Key way width	<=16 mm	-0.06 to -0.02 mm
Key way width	>16 mm	-0.07 to -0.02 mm
Key way depth	<= 3.8 mm	0.1 mm to -0.00
Key way depth	>3.8 mm	0.2 mm to -0.00

- 3.19 All actuators shall have removable output bush.
- 3.20 No part of actuator shall protrude beyond secondary gear box flange.
- 3.21 All the basic actuators and the gear boxes should have undergone endurance testing. Reference standards are EN15714 for basic actuator and AWWA standard for Gear box.
- 3.22 Supplier shall confirm self locking is provided in their design. Further to self Locking, the supplier shall confirm over travel will not be there in their design i.e., when power is switched off, gear box should not rotate and gate should not come down on its own. Supplier shall give specific confirmation to this point.
- 3.23 Sizing calculation to be furnished along with the offer for new models which are not supplied to BAP Ranipet earlier.

VENDOR SIGNATURE:

(with seal):



**BHARAT HEAVY ELECTRICALS LIMITED**  
**BOILER AUXILIARIES PLANT**  
**ELECTRICAL, CONTROLS AND INSTRUMENTATION**  
**RANIPET - 632 406.**

**TDA:STD:OCE:001**  
**REV. 02**  
**SHEET 7 OF 13**

**“ TECHNICAL INFORMATIONS “**

(VENDOR TO COMPLETELY FILL UP AND FURNISH COPIES ALONG WITH OFFER )

ABSENCE OF ANY DETAIL WILL BE CONSIDERED AS NON RESPONSIVE OFFER AND LIABLE FOR REJECTION.

SPECIFY TOLERANCE WHERE EVER APPLICABLE - ( REQUIRED TO BE CHECKED DURING TESTING / INSPECTION )

SL.NO	SPECIFICATION REQUIREMENT	ACTUATOR SL.NO			
		001	002	003	004
1.0	Actuator type chosen. <u>MOTOR:</u>				
2.0	Type & frame size.				
2.1	Rating ( Voltage / KW )				
2.2	Starting current. ( A )				
2.3	Current at run torque (15 min. torque for louver & 6 min. torque for gate ).				
2.4	Full load current ( at 100% Torque setting )				
2.5	Current at dynamic stall ( Locked rotor )				
2.6	Permissible locked rotor withstand time.				
2.7	A. Starting Torque. B. Run Torque. C. Class of Insulation. D. Stator winding Star or Delta. ( Delta Preferable)				

**VENDOR SIGNATURE:**  
(with Seal)



**BHARAT HEAVY ELECTRICALS LIMITED**  
**BOILER AUXILIARIES PLANT**  
**ELECTRICAL, CONTROLS AND INSTRUMENTATION**  
RANIPET - 632 406.

TDA:STD:OCE:001  
REV. 02  
SHEET 8 OF 13

SL.NO.	SPECIFICATION REQUIREMENT	ACTUATOR SL.NO.			
		001	002	003	004
2.8	Full load torque ( 100 % Torque setting ).				
2.9	A. No. of starts per Hr at no load condition. B. No. of starts per Hr with load at specified run Torque. C. Full load RPM. D. Ambient temp. in ° C ( - 20° C to + 50° C ). E. Duty time (S2-15min.) F. Full load power factor. G. Full load efficiency.				
	<b><u>GEAR BOX :</u></b>				
3.0	A. Primary Gear Box Ratio. B. Primary Gear Box Efficiency.				
3.1	Primary GB maximum output torque (KGM)				
4.0	A. Secondary GB type & make. B. Secondary GB Ratio. C. Secondary GB efficiency.				
4.1	Secondary GB maximum torque (KGM)				
4.2	A. Secondary GB continuous torque capacity. B. Secondary GB momentary torque capacity.				
5.0	Actuator + Secondary GB output RPM .				
5.1	A. Actuator + Secondary GB torque range (KGM) ( 15 min. torque for louver & 6 min. for gate.) B. Secondary GB lead angle less than or equal to 6° . C. Worm & worm wheel material.				

VENDOR SIGNATURE :  
(with Seal)



**BHARAT HEAVY ELECTRICALS LIMITED**  
**BOILER AUXILIARIES PLANT**  
**ELECTRICAL, CONTROLS AND INSTRUMENTATION**  
RANIPET - 632 406.

TDA:STD:OCE:001  
REV. 02  
SHEET 9 OF 13

SL.NO.	SPECIFICATION REQUIREMENT	ACTUATOR SL.NO.			
		001	002	003	004
5.2	Actuator + Secondary GB starting torque (KGM).				
5.3	Actuator + Secondary GB dynamic stall torque (KGM).				
5.4	Bore Dia. x length of Secondary GB (mm).				
5.5	Approximate Weight of actuator + Secondary GB.				
5.6	Lubrication : A. Recommended interval of checking / filling. B. Type of lubricant. C. Indian equivalent make. D. Qty. in Litres / Kg .				
5.7	Type and make of Limit switches and Torque switches.				
5.8	Actuator + Secondary GB paint. A. Colour. B. Paint thickness.				

**VENDOR SIGNATURE:**  
(with Seal)



**BHARAT HEAVY ELECTRICALS LIMITED**  
**BOILER AUXILIARIES PLANT**  
**ELECTRICAL, CONTROLS AND INSTRUMENTATION**  
**RANIPET - 632 406.**

**TDA:STD:OCE:001**  
**REV. 02**  
**SHEET 10 OF 13**

**TEST REQUIREMENTS FOR "ACTUATOR+ SECONDARY GEAR BOX"**

**T (A) ROUTINE TEST:**

1. Dimensions. : Overall and Mounting.
2. Painting : Anti - Corrosiveness Epoxy.
  - i) Shade.
  - ii) Finish.
  - iii) Paint Thickness - (min. 80 mm)
  - iv) Peel off test
3. Manual operation through hand wheel. :
4. Checking of wiring - BHEL Std. TB Diagram :
5. Testing of position and torque limit switches for accuracy and repeatability. By turn setting ( No. of turns ) for position limit switches & torque setting for torque switches. :
6. Hand - Auto switching function: :
7. For motor, all routine tests as per IS:325/BS 4999 - Part 60 :
8. Final output speed and torque of Actuator+ Secondary Gear Box and corresponding current as per catalogues :
9. Position indicator and transmitter : calibration check for accuracy, linearity and repeatability. :
10. Leakage test for gear casing ( Visual ). :

**VENDOR SIGNATURE :**  
(with Seal)



**BHARAT HEAVY ELECTRICALS LIMITED**  
**BOILER AUXILIARIES PLANT**  
**ELECTRICAL, CONTROLS AND INSTRUMENTATION**  
**RANIPET - 632 406.**

**TDA:STD:OCE:001**  
**REV. 02**  
**SHEET 11 OF 13**

11. HV test at 1.6 KV ( 80 % of 2 KV ) :  
for the assembled actuator
12. Operation of " Actuator + Secondary :  
Gear Box " under variation in supply  
voltage ( $\pm 10\%$ ) and variation in  
frequency ( $\pm 5\%$ ) for verifying  
SPECIFIED RUN TORQUE and speed.
13. Checking of actuator Bore Dia. X length :  
and keyway dimension.

**T ( B ) TYPE TESTS :**

1. Type test for motor as per IS: 325/ :  
BS:4999 -Part 60.
2. Noise and vibration test for total assembly :  
as per IS: 4729/BS 4999- Part 60.
3. Temperature rise test during, :  
A. Operation of actuator at 75% voltage  
for 5 minute.
- B. Operation of actuator at 50° C ambient :  
temp.
4. Enclosure protection for the total assembly :  
for IP:55 as per IS:13947/1993/PART-1
5. Endurance test for actuator. :
6. Mechanical and Electrical endurance test :  
for limit switches .
7. All tests listed under routine test :
8. Damp heat cycle test as per IS 9000/IEC-68-30. :

**NOTE: Electrical Actuators for Neyveli project shall  
be of Protection Class: IP-67 without Integral  
Starter.**

**VENDOR SIGNATURE :**  
(with Seal)



**T(C) 1 PERFORMANCE TEST OF ACTUATORS**

**(A) RUN TORQUE TEST**

15 min. Torque for louver & 6 min. torque for gate. Place the beam connected to the actuator in the horizontal position and add weights corresponding to run torque & (with torque switches active) Ref. Fig. 1. Operate the Actuator for 15 minutes for louvers & 6 minutes for gate.

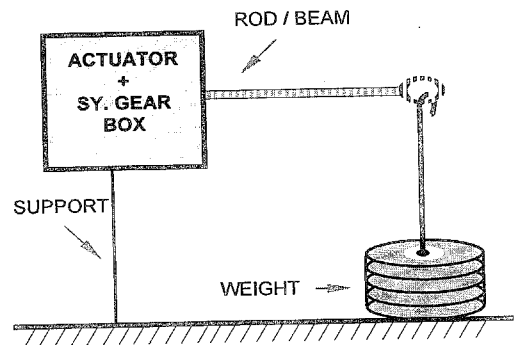

Fig.1

**(B) DYNAMIC STALL TORQUE TEST**

1. Remove all the weights from the damper simulator beam.
2. Run the actuator without load until it hits a U-bolt arrangement which has weights attached to the bottom of it. (Ref. Fig. 2).
3. Add weights until the actuators cannot lift the U-bolt arrangements from the horizontal position.

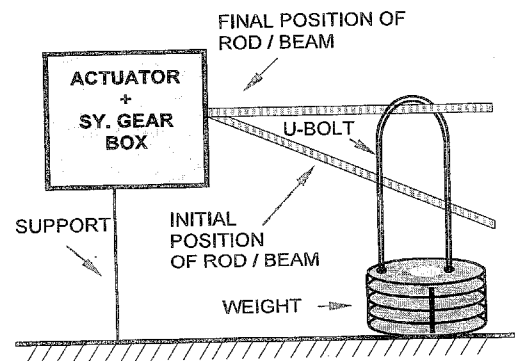

Fig.2

**(C) GEAR BOX STURDINESS TEST**

Repeat the run torque test and ensure that there is no damage of gear box of actuator.

**VENDOR SIGNATURE :**  
(with Seal)



**BHARAT HEAVY ELECTRICALS LIMITED**  
**BOILER AUXILIARIES PLANT**  
**ELECTRICAL, CONTROLS AND INSTRUMENTATION**  
**RANIPET - 632 406.**

**TDA:STD:OCE:001**  
**REV. 02**  
**SHEET 13 OF 13**

**T (D) DOCUMENTS TO BE PROVIDED**

1. Certificate for routine test detailing out the results :
2. Routine and type test reports for motors. :
3. Type test report for tests listed under T ( B ) . :
4. Material test certificate for casting, gear, shaft etc. :
5. Endurance test for limit switches. :
6. Detailed catalogues, O&M manuals & data sheets :
7. List of recommended / commissioning spares & commissioning tools required :

**T (E) NOTES :**

1. The tests should also be in conformity to the QP ( Quality Plan ) submitted by the supplier and approved by BHEL / Customer.
2. All testing facilities shall be arranged by the vendor at his works before calling BHEL representative for inspection.
3. Approved drawings, P.O., Specification and relevant standards shall be made available during testing / inspection.
4. All measuring and testing instruments shall be periodically calibrated from National test house and certificate made available during inspection.

**VENDOR'S NAME :**

**VENDOR'S REF. :**

**DATA SHEET**  
**DS 57683**

TECHNICAL SPECIFICATION FOR HOT SECONDARY AIR TO BURNER- DAMPERS		
<b>KKS-No.</b> Note: Actuator with KKS tag nos. ending with AA101, 103 & 105 are used to operate the extreme flaps of damper. Actuator with KKS tag nos. ending with AA102, 104 & 106 are used to operate the Middle 50% damper area.	01 HHL10 AA105 01 HHL10 AA103 01 HHL10 AA101 to 01 HHL80 AA105 01 HHL80 AA103 01 HHL80 AA101	+01 HHL10 AA106 +01 HHL10 AA104 +01 HHL10 AA102 to +01 HHL80 AA106 +01 HHL80 AA104 +01 HHL80 AA102
<b>Designation</b>	Hot Secondary Air to Burner Shut-off Damper <b>[For Damper sketch, refer Page 2 of 2]</b>	
Mounting locality - outside / inside	outside	
Ambient temperature (°C) min/max	+27	
Ambient pressure (mbar), absolute	1005	
Fluid	Hot Air with traces of ash particles (erosive)	
<b>Operating case</b>		
mass flow (kg/s)	6.5	6.4
Norm Density ( (kg/ m³N)	1.276	1.276
Norm Volumetric Flow (Nm³/h)	18.249	18.249
<b>Velocity (m/sec)</b>	<b>16</b>	<b>16</b>
<b>Operation temperature (°C)</b>	<b>340.5</b>	<b>340.5</b>
<b>Operating pressure (mbar)</b>	<b>22</b>	<b>22</b>
Actuation Type ( Open-Close / Regulating / Inching Mode)	Open-Close	Open-Close
Mode of Driving (Hand / electrical / pneumatic)	Electrical	Electrical
positioning time (s)	<b>60</b>	<b>60</b>
<b>Operating Data</b>		
Design Pressure (mbar)	+50 / -60	+50 / -60
Design Temperature (°C)	370	370
<b>Damper data</b>		
number of parts	24	
Type of construction (a. e. window-shade/Isolating damper/Tandem)	Split Damper	
number of Blades-pieces	*vendor to specify	*vendor to specify
Material of Blades	P265GH (or) better material - Vendor to specify	P265GH (or) better material - Vendor to specify
Material of casing	<u>External parts:</u> IS2062 (or) S235JR (or) better material - Vendor to specify. <u>Medium exposed parts:</u> P265GH (or) better material.- Vendor to specify	<u>External parts:</u> IS2062 (or) S235JR (or) better material - Vendor to specify. <u>Medium exposed parts:</u> P265GH (or) better material.- Vendor to specify
Material of shaft	SA479 Type 304 (or) better material - Vendor to specify	SA479 Type 304 (or) better material - Vendor to specify
mounting position duct (horizontal / vertical)	horizontal	horizontal
mounting position damper (horizontal / vertical)	vertical	vertical
mounting position shaft (horizontal / vertical)	vertical	vertical
mounting position Blade (horizontal / vertical)	vertical	vertical
Opening direction of Blades parallel or counterrotate	with flow	with flow
Type		
<b>overall external dimension of duct B x H x t</b>	<b>2 x (450 x 800 x 5)</b>	<b>1 x (900 x 800 x 5)</b>
clear width of damper B x H	*vendor to specify	*vendor to specify
<b>Fitting length</b> (Gap available in duct for mounting the damper)	<b>500 mm +</b> (20 mm on either side available for mating flange)	

Weight per unit / approx.kg	*vendor to specify	*vendor to specify
Type of sealing	*vendor to specify	*vendor to specify
theoretical sealing gap (mm)	*vendor to specify	*vendor to specify
<b>max. tolerable pressure drop (mbar)</b>		
sealing air volume (kg / s)	NOT APPLICABLE	NOT APPLICABLE
<b>Mechanical end stop adjustable</b>	<b>Yes</b>	<b>Yes</b>
number of pieces	1 x open / 1 x close	1 x open / 1 x close
<b>Mechanical locking device</b>	<b>Yes</b>	<b>Yes</b>
number of pieces	1 x open / 1 x close	1 x open / 1 x close
<b>Mechanical Position Indicator</b>	<b>Yes</b>	<b>Yes</b>
number of pieces	1 x on drive shaft arranged	1 x on drive shaft arranged
Design / Scale	scale 5° grading	scale 5° grading
<b>Required actuator torque (Nm)</b>	*vendor to specify	*vendor to specify
Electrical Actuator Make & Model No.	*vendor to specify	*vendor to specify
Voltage (V)	415 V, 3 phase	415 V, 3 phase
Frequency (Hz)	50 Hz	50 Hz
Electrical warm up current IA (A)	*vendor to specify	*vendor to specify
Nominal Current IN (A)	*vendor to specify	*vendor to specify
<b>Gear (suggestion)</b>	*vendor to specify	*vendor to specify
<b>input torque (Nm)</b>	*vendor to specify	*vendor to specify

Secondary air to burner  
shut-off damper

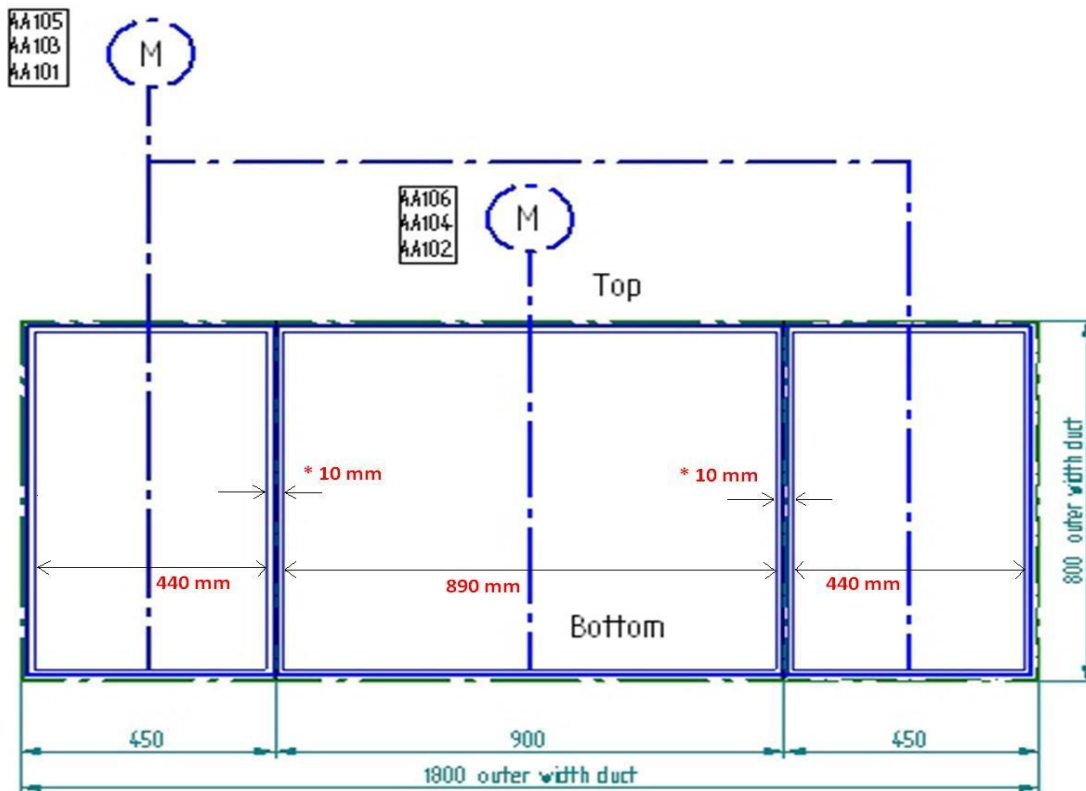

01 HHL10 AA105 + 01 HHL10 AA106 Burner 1 upper level  
01 HHL10 AA103 + 01 HHL10 AA104 Burner 1 intermediate  
01 HHL10 AA101 + 01 HHL10 AA102 Burner 1 lower level

1) THICKNESS OF DUCT = 5mm  
2) \* PLATE THICKNESS OF INTERMEDIATE WALL = 10mm

CL-57683

**CHECKLIST for Hot Air to Burner Compartments-Dampers ( NEYVELI NEW  
THERMAL POWER PROJECT 2X500 MW)**

(Vendor shall submit this checklist duly filled along with Technical offer)

Sl. no:	DOCUMENTS	Furnished status / Confirmation (Yes/No)
1	Filled up Data sheets - DS-57683	
2	Comments /Acceptance/Deviations against the General specification as per GDRS: 022	
3	Proforma Invoice – PI-57683 filled and enclosed	
4	Mandatory spares (Electrical Actuators ) price considered in the proforma Invoice PI-57683	
5	Commissioning support (supervision) charges conforming to Technical specification GDRS: 022, Clause No: 12.0 and included in PI-57683, Sl. No: 3.	
6	Scope of supply clearly indicating terminal points & exclusions.	
7	General arrangement drawing enclosed with Technical offer showing: a) Overall Dimensions of Damper with all accessories with BOM, b) Material of construction, c) weight details and d) details required in Clause No. 5.0.	
8	Bidder's Quality plan for the offered damper.	
9	Spares list quoted & valid for a period of 3 years: a) Commissioning spares b) Recommended spares for three years trouble free operation	
10	Reference list details & G.A. drawings satisfying the Qualification Requirements enclosed as per GDRS: 022, Clause No: 15.0.	
11	Vendor confirmation for submission of specified drawing / document for approval (as specified in the general specification GDRS: 022, Clause No: 16.0) after placement of purchase order.	
12	Bidder's confirmation of leak tightness testing to meet $\geq 99.50\%$ efficiency on Surface area method.	

**PI-57683**

**PROFORMA INVOICE / PRICE BID for HOT AIR TO BURNER COMPARTMENTS-DAMPERS**

**PROJECT : NEYVELI NNTPP - 2X500 MW (R550 & R551) , ENQUIRY NO: \_\_\_\_\_**

The scope of supply shall mandatorily cover the following items and the "Quantities" indicated against each item description in the table.

Sl. No.	Description	Unit	Quantity	Quoted Yes / No	Unit Rate	Total Price
1	HOT AIR TO BURNER COMPARTMENTS DAMPERS WITH MATING FLANGES AS PER GDRS:022/00	NOS	48			
2	ELECTRIC ACTUATORS AS PER SPECIFICATION TDA:STD:OCE:001/REV02 FOR DAMPER'S MIDDLE FLAP.	NOS	48			
3	ELECTRIC ACTUATORS AS PER SPECIFICATION TDA:STD:OCE:001/REV02 FOR DAMPER'S EXTREME FLAPS.	NOS	48			
4	MATING FLANGES WITH CONNECTION BOLTS (UPSTREAM AND DOWNSTREAM SIDES) - [Note: 48 Sets means 48 Damper requirement]	SET	48			
5	MANDATORY SPARES CONSISTING OF: I) ELECTRICAL ACTUATORS - 1 NO. OF EACH TYPE / MODEL / MAKE / RATING) REFER CLAUSE 13.0 (b) OF GDRS:022) - [Note: 1 Set means 1 Actuator for Damper's Middle Flap + 1 Actuator for Damper's Extreme Flaps]	SET	1			
6	Commissioning Supervision Support as per clause no. 12.0 of GDRS: 022	SET	1			
Grand Total price for above scope (Sl. nos. 1 to 6)						

**Vendor's signature with seal**

**NOTE:** 1. The price break-up should be in line with technical specification / scope of the tender. All charges like Cost of basic machine, spares, packing charges, forwarding charges {FOB / FCA}, freight, insurance and commissioning supervision charges shall be shown separately. Under no circumstances shall the Commissioning Supervision charges be included in supply.

2. In unpriced PRICE BID, bidder has to indicate "Quoted" against the columns "Unit Rate" and "Total Price" in above Table. The numerical values ( Price) for all the above to be quoted in "price bid" only. No conditional clause shall be inserted into price bid by bidder. Any conditions added in price bid will cause rejection of bidder's offer. Certified that all items indicated in above table are covered in scope of supply.