



General Note: **BHARAT HEAVY ELECTRICALS LIMITED**

(A Government of India Undertaking)
HIGH PRESSURE BOILER PLANT
PURCHASE DEPARTMENT - FOSSIL BOILERS
THIRUCHIRAPALLI - 620014
TAMILNADU (INDIA)

PHONE : 2577419
GRAMS : BHARATELEC
FAX NO: 2520719
E-mail :
Web :

429-002/A

OFFICE COPY	Collective No.	Enquiry Date	Due Date For Quotation
	1901600070	26.03.2016	20.04.2016
Please quote Enquiry No, Date and due date in all correspondences. This is only a request for quotation and not an order			

Item	Description	Unit	Quantity	Delivery Quantity	Schedule Date
10	413244027200 HEX.NUT M72X4(LH)GR B BPS-41324/04 & TDC:5:166 REV.04	NO	150.000	150.00	16.05.16
20	413246006400 HEX NUT M64 X 6 SA194 GR 7 BPS-41324/04 & TDC:5:166 REV.04	NO	2300.000	2,300.00	16.05.16

General Note:

SUPPLY OF NUTS FOR HIGH TEMPERATURE USE
THIS ENQUIRY IS A TWO PART BID E-PROCUREMENT ENQUIRY

TERMS AND CONDITIONS:

1. THE MODE OF THIS TENDER IS THROUGH E-PROCUREMENT. OFFERS IN ANY OTHER MODE WILL NOT BE ACCEPTED. REFER POINT.1 OF ANNEXURE-A
2. TEST CERTIFICATE & GUARANTEE CERTIFICATE SHOULD BE PROVIDED ALONG WITH SUPPLY.
3. DELIVERY IS 50% WITHIN 30 DAYS FROM PO DATE AND NEXT 50% WITHIN 60 DAYS FROM PO DATE.

ENCLOSURES:

1. ANNEXURE - A (GENERAL TERMS AND CONDITIONS)
2. ANNEXURE - PQC (PRE QUALIFICATION CRITERIA)
3. ANNEXURE - B (TECHNO COMMERCIAL BID)
4. ANNEXURE - 1 (FOR MSE VENDORS)
5. ANNEXURE - N (FOR NEW VENDORS)
6. PLANT STANDARD: BPS-41324
7. TECHNICAL DELIVERY CONDITIONS- TDC:5:166 REV.04

Enclosures:

"LD clause has to be confirmed without fail."

The bidder along with its associate / collaborators / sub-contractors / sub-vendors / consultants /service providers shall strictly adhere to BHEL fraud prevention policy displayed on BHEL website <http://www.bhel.com> and shall immediately bring to the notice of BHEL Management about any fraud or suspected fraud as soon as it comes to their notice.

PR Links

The offers should reach us 30 minutes before the time of opening of tenders.
The offers will be opened at 14.30 hrs on the due date of tender in the presence of tenderers who have submitted their offer and who may like to be present for the tender opening.Late and delayed offers are liable to be rejected.

Yours faithfully,
For **BHARAT HEAVY ELECTRICALS LIMITED**

K. RAJA PRAKASH
MANAGER / PURCHASE
(FOSSIL BOILER ENGINEER)

MM / Purchase / PSS
BHEL, TRICHY - 620 014.



BHARAT HEAVY ELECTRICALS LIMITED

(A Government of India Undertaking)
HIGH PRESSURE BOILER PLANT
PURCHASE DEPARTMENT - FOSSIL BOILERS
THIRUCHIRAPALLI - 620014
TAMILNADU (INDIA)

Page:2/2

1901600070 / 26.03.2016

23505

Material.	PR.No	PR.Item.	Quantity	Acc. Assign	Customer Number
413244027200	114811435	00020	150.000	/000000	
413246006400	114811435	00010	2300.000	/000000	

list of suppliers

RFQ-5200004803

Open Tender Dummy Code

The offers should reach us 30 minutes before the time of opening of tenders.
The offers will be opened at 14.30 hrs on the due date of tender in the presence of tenderers who have submitted their offer and who may like to be present for the tender opening. Late and delayed offers are liable to be rejected.

Yours faithfully,
For BHARAT HEAVY ELECTRICALS LIMITED

26.02.16
K. RAJA PRAKASH
Engineer
MANAGER, PURCHASE
(FOSSIL BOILERS)
Yours faithfully,
Purchase / PSS
BHEL, TRICHY - 620 014

Annexure A

QUOTATIONS:

1.

a. Interested bidders / Suppliers shall submit their offer through e-Procurement mode at <https://bheleps.buyjunction.in>. **Offers in any other mode will not be accepted.**

For Enterprise Procurement System (EPS) Bidders/Suppliers are requested to follow these steps.

REQUIREMENTS

1. A PC with Internet connectivity.
2. DSC (Digital Signature Certificate)(Class 3- SHA2- 2048 BIT- SIGNING & ENCRYPTION)
3. The site is best viewed in Internet Explorer 9.0. If you are using Internet Explorer 10 or above then enable compatibility view available under Tools menu
4. Install Java 1.7 Update 67/72/79 (Both 32 & 64 Bit

MANDATORY REQUIREMENT:

Suppliers interested for registration for BHEL Open Tenders should have a valid DSC (Digital Signature Certificate) before Proceeding forward for Registration. Herein a Valid DSC refers to an Active and unexpired Signing and Encryption Certificate, with specification Class III SHA 2 2048 bit.

UNREGISTERED SUPPLIER IN EPS:

Procedure for Online Registration in EPS for Open Tender Suppliers for BHEL

Please follow the below steps for registration

1. Click Register Button (Top of the Screen)
2. Please input your organization PAN No (in case of Indian supplier) or click "Foreign" in case you are an overseas Supplier.
3. Click on INTERESTED Button against the respective BHEL Unit
4. Key in your desired login id (Login Code should be 8 - 24 characters in length and can only use numeric values) If you have registered by keying in PAN No. then your desired login id will be prefixed by "OTI", In case of overseas suppliers it will be prefixed with "OTF"
5. Fill in the other details.
6. Fill in the Captcha code and click next
7. Register your Signing certificate and click next
8. Select atleast one procurement category you may be dealing in.

Once the above steps are completed, your profile will be activated by mjunction within 2 business hours. After registering follow the steps provided in "For Registered Supplier" to view RFQ.

In case of any assistance, please call the following nos for support:

033-6601 1717 (From 9:30am to 5:30pm)

NB:-

1 -- BHEL Administrator or user will have no role for approving Registration and Open Tenders and DSC for Any supplier who has registered himself from the front END which is in case of OT.

FOR REGISTERED SUPPLIER IN EPS:

- a. Supplier visits EPS home page
- b. Supplier signs in with their user id and password
- c. Selects the RFQ Code and views it.
- d. Attaches themselves to the RFQ by clicking the interested button
- e. Supplier fills the bid template and makes necessary attachments
- f. Supplier submits their bid by clicking CONFIRM.

In case of any assistance, please call the following Nos for support:

033-6601 1717 (From 9:30am to 5:30pm)

b. Bidders are requested to quote their offer price on F.O.R Destination (BHEL/Stores) basis only (The basic price of the material quoted in the bid should be inclusive of Packing, Forwarding, freight and transit insurance, etc.). Ex-works offers will be summarily rejected without further clarification.

c. No charges shall be indicated as "Lumpsum" or "Approximate" in absolute value. All charges like taxes and duties should be clearly specified as "percentage" of the quoted rates.

d. If any sales tax is payable as extra to the quoted price should be specifically stated in quotations along with CST & TIN no failing which the purchaser will not be liable for payment of sales tax. Our TIN No. 33243560005 Dated. 01.01.2007, CST No.239383 Dtd.11.06.1991.

e. Manufacturer's name, trademark or patent no. if any should be specified. Illustrative leaflets giving technical particulars are required along with quotation wherever necessary.

f. Products with I.S.I. certification marks will be preferred.

g. The Purchaser shall be under no obligation to accept the lowest or any other tender and shall be entitled to accept in Part or full without assigning any reason whatsoever.

h. The bidder has to keep track of any changes by viewing the addendum / Corrigendum's issued by the Purchaser on time-to- time basis in the E-Procurement platform. The Company calling for tenders shall not be responsible for any claims/problems arising out of this.

i. The user should complete all the processes and steps required for bid submission. The successful bid submission can be ascertained once acknowledgement is given by the system through bid submission number after completing all the processes and steps. BHEL and mjunction Services Ltd. will not be responsible for incomplete bid submission by users. Users may also note that the incomplete bids will not be saved by the system and are not available for the Purchaser for processing.

j. Before uploading scanned documents if any, the bidders shall sign on all the statements, documents, certificates uploaded by him, owning responsibility for their correctness / authenticity.

2. Offers should have a validity of minimum 90 days from the date of price bid opening. The quoted/Finalized rates shall be Firm till completion of the supplies including amendment / deviation / extension if any in quantity / date.

3. On the due date of tender opening, only technical bids will be opened. The opened technical bids will be evaluated by us and clarifications required, if any, will be called for from the bidders on technical and commercial points. If no reply is received from the vendor for the clarification raised by BHEL with in the final cut-off date those vendors offer will be processed with the documents available / submitted against this tender. Offers not meeting the required specification and technical condition will be summarily rejected. The price bids of technically suitable bidders will be opened on a later date with prior intimation to techno-commercially suitable bidders.

4. Ranking L-1, L-2 etc. shall be done for individual items for the techno-commercially acceptable offers on landed cost to BHEL, Trichy basis and BHEL reserves the right to place order for individual items with different vendors. In the event of more than one vendor becoming L1 for the item, the enquiry quantity will be shared equally among all the L1 vendors. For such item / items splitting will be done among L1 vendors along and not mentioned in the point no 10 below.

5. BHEL reserves the right to negotiate with L1 vendor or re-float the tender for items where, L1 price is not the lowest acceptable price; BHEL reserves the right to increase or decrease the tender quantity.

6. **TERMS OF PAYMENT:** Payment will be made after 45 days from the date of receipt and acceptance of materials at BHEL Trichy. Offers quoting for Advance payment / LC / thro bank payment will be rejected. Any deviation in the payment terms below 45 days shall attract loading as below.

Base rate of SBI (as applicable on the date of bid opening; Techno-commercial bid opening in case of two part bids) +6%' will be considered for the loading for the period of relaxation sought by the bidder.

7. LD clause & Risk purchase clause are applicable.

(Any deviations in the LD shall attract loading to the extent of relaxation sought to which it is not agreed by the bidder at offered value).

Single delivery schedule:

If the Supplier fails to deliver the P.O quantity within the period specified in the contract, then the Purchaser shall deduct liquidated damages, 0.5% of the total order value per week of delay or part thereof subject to a maximum of 10% of the total order value.

Staggered delivery schedule

In case of staggered delivery schedule, if the Supplier fails to deliver the quantity of any line item of the P.O within the period specified in that line item, Purchaser shall deduct Liquidated Damages, 0.5% of the undelivered portion per week delay or part thereof subject to maximum of 10% of the total order value

Liquidated Damages (LD): (Any deviations shall attract loading to the extent of relaxation sought to which it is not agreed by the bidder at offered value).

RISK PURCHASE: Alternatively the purchaser at his option will be entitled to terminate the contract and to purchase elsewhere at the risk and cost of the seller either the whole of the goods or any part which the supplier has failed to deliver or dispatch within the time stipulated as aforesaid or if the same were not available, the best and the nearest available substitutes therefor. The supplier shall be liable for any loss, which the purchaser may sustain by reason of such risk purchases in addition to penalty at the rate mentioned in LD clause above.

8. **CENVAT CREDIT:** If any Excise Duty is payable, the Chapter Head / Sub -head reference and the rate of the duty should be quoted. If the tenderer is availing CENVAT credit for this input material, the effect of Proforma credit should be passed on to the purchaser. Tenderer under "CENVAT" shall be preferred. In case of ordering vendor should issue CENVAT invoice along with the material.

9. **PACKING AND MARKING:** The supplier shall arrange for securely protecting and packing the stores to avoid loss or damages during transit.

10. SPECIAL PROVISIONS FOR MICRO AND SMALL ENTERPRISES (MSE) BIDDERS:

- i. 20% of the tendered quantity is earmarked for MSE suppliers in this tender. (Applicable only for items whose Quantity is 1000 Nos. or more than 1000 Nos)
- ii. Out of the 20% tendered quantity reserved for MSE suppliers, 4% shall be earmarked for procurement from MSE owned by SC / ST entrepreneurs. In event of failure of such Micro and Small enterprises to participate in the tender process or meet the tender requirements and the L1 price, the 4% sub-target for procurement ear-marked MSE owned by SC / ST entrepreneurs shall be met with other MSE enterprise/s.
- iii. In case MSE vendor participating in the tender quotes within the price band of L1 + 15%, they will be allowed to supply the portion of the requirement subject to acceptance of L1 price by MSE vendor. In case of more than one such MSE, the supply shall be shared proportionately.
- iv. MSE suppliers can avail the intended benefits only if they submit along with the offer, attested copies of either EM II certificate having deemed validity (five years from the date of issue in acknowledgement in EM II) or valid NSIC certificate or

EM II certificate along with attested copy of a CA certificate (Format enclosed as per **Annexure I** where deemed validity of EM II certificate of five years have expired) applicable for the relevant financial year (latest audited). Date to be reckoned for determining the deemed validity will be the date of bid opening (Part 1 in case of two part bid). Non submission of such documents will lead to consideration of their bids at par with other bidders. No benefits shall be applicable for the enquiry if any deficiency in the above required documents is not submitted before the price bid opening. If the tender is to be submitted through e-procurement portal, then the above required documents are to be uploaded on the portal. Documents should be notarized or attested by a Gazetted officer. This provision for MSE will apply subject to the condition that the participating MSE meets the tender requirements.

- v. In case of any change in the MSE status of the bidder, it shall be the responsibility of the bidder to notify the change as a part of the bid document. If at a later date it comes to the knowledge of BHEL, that the change in the status has not been intimated by the bidder and the order is obtained under the premise of an MSE then BHEL would cancel the pending order against this tender and take necessary steps for suspension of the business dealing with the bidder as per the procurement policy of BHEL.
- vi. In case after the bid opening it is seen that no MSE has become L1, then depending on the nature of the item, if it is not possible to split the tendered items / quantities on account of reasons like customer contract requirements of supplying one make for a given project or technical reasons like tendered items being a system, tendered quantity being low etc., then BHEL would not counter offer the L1 prices even though there may be MSE bidders within the +15% band of L1.

10.1

- a. 20% of the tendered quantity is earmarked for MSE suppliers in this tender. The earmarked 20% quantity will be counter offered to the MSE vendors whose rate is within L1+15% band & up to H1 of MSE. In case of non-acceptance of the counter offering of 20% reservation to MSE vendors, the total tender quantity will be ordered as mentioned in 10.1 (c). For the balance 80% of the tendered quantity, BHEL reserves the right to order the tender quantity 100% on L1 vendor. Counter offering of L1 rate will not be made with any H1 vendor of Non-MSE
- b. If L1 is from a Micro / Small enterprise, the 20% earmarking provision is not applicable and order will be split in the ratio of 70:30 (between L1 , L2 / L3 at matched L1 F.O.R rate in the order of commercial ranking). Counter offering of L1 rate will not be made with any H1 vendor of Non-MSE.
- c. If there is no response form MSE vendors the above split up of 10.1 (a) & 10.1 (b) will not be applicable and the total tender quantity will be split and ordered in the ratio of 70:30 (between L1 , L2 / L3 at matched L1 F.O.R rate in the order of commercial ranking .
- d. In case of counter offering rate does not accepted by the L2 as well as L3 vendor, such counter offer quantity also will be ordered on L1 vendor.

11. For the enquired items, where the quantity is 1000 No's and less than 1000 No's will not be split as mentioned in the Sl. No 10. Such items will be ordered on L1 vendor alone.

12. Conditional offers are likely to be rejected.

13. The correspondences between the bidder and BHEL through email are considered as valid document legally though not signed. It is treated as valid confirmations made on behalf of the respective company and comes under the legal ambit of the business transaction and hence binding on both the parties.

14. Disclaimer Clause: Neither the Organization (Bharat Heavy Electricals Ltd.) nor the service provider (mjunction Services Ltd.) is responsible for any failure of submission of bids due to failure of internet or other connectivity problems or reasons thereof.

15. Bidders participating in the tender should declare in their technical bid whether they have been black-listed / kept on hold / given Business holiday for a specified period by any Public Sector Undertaking or Government Departments. The reasons for such action with details and the current status of such hold shall be clearly furnished to BHEL. If no such details are mentioned in the offer, it will be construed that the bidder is not under any such hold. However, at a later date if it comes to the notice of BHEL about any such hold under enforcement, BHEL reserves the right to reject the offer at any point of time and also under any stage of the finalization of the tender. Such bidders will not be permitted to participate in the further tender proceedings and will be communicated suitably.

16. BHEL reserves the right to negotiate or re-float the enquiry opened if L1 price is not the lowest acceptable price to them inter-alia other reasons.

17. The correspondence between the bidder and BHEL through email is considered as valid document legally though it is not signed. It is treated as valid confirmations made on behalf of the respective company and comes under the legal ambit of the business transaction and hence binding on both the parties.

18. In case of any quality rejection of materials, the supplier has to collect the materials at his own cost within the 10 days of rejection of advice. Otherwise the materials will be scrapped.

19. Unloading at BHEL has to be done by the suppliers and BHEL will not be in a position to provide any handling / unloading facilities.

20. Bidders not confirming to the enquiry specifications will be disqualified.

ANNEXURE - PQC

ENQ.NO:

	Material: HEX nuts for high temperature use as per BPS:41324	
Sl.No	PRE QUALIFICATION CRITERIA ---Points	Vendor to confirm
01	<i>Acceptance for supplying HEX nuts as per standard indicated for Each item</i>	ACCEPTED / NOT ACCEPTED
02	<i>Balance sheet for the past three financial years along with audit report (FY 12-13, FY 13-14, FY 14-15)</i>	ENCLOSED / NOT ENCLOSED
03	<i>Experience in supplying HEX nuts for high temperature use to various industries. The vendors should enclose a purchase order copy against their experience during the past three years starting from 1 jan 2013 in the supply of HEX nuts for high temperature use to various industries.</i>	ENCLOSED / NOT ENCLOSED
04	<i>Bidders have to confirm whether they have been black-listed / kept on hold / given Business holiday for a specified period by any Public Sector Undertaking or Government Departments/any other units of BHEL. (With reference to S.No.15 of Annexure – A).</i>	YES / NO
05	<i>Agreed to Delivery schedule provided by BHEL</i>	YES / NO
06	<i>Offers from Manufacturers will only be accepted. Offers from Traders or agents will summarily be rejected.</i>	MANUFACTURER / TRADER

NOTE:

Offers meeting the above prequalification criteria points only will be evaluated further. Otherwise it will summarily be rejected.

SIGN AND SEAL OF AUTHORIZED PERSON

TECHNO COMMERCIAL BID
TO BE SUBMITTED ALONG WITH PART - I (TECHNO COMMERCIAL BID)

ANNEXURE -B

S. NO	DESCRIPTION	BHEL REQUIREMENTS	SUPPLIER CONFIRMATION / DEVIATION (STRIKEOUT WHICHEVER IS NOT APPLICABLE)
1	VALIDITY	90 DAYS FROM DATE OF TECHNICAL BID OPENING	NON DEVIATABLE
2	PRICE QUOTED	FOR-DESTINATION BHEL STORES / TRICHY	NON DEVIATABLE
3	EXCISE DUTY WITH CESS	SUPPLIER OPTION	INCLUSIVE / EXTRA (Please quote % below) _____ %
4	VAT / CST against form 'C'	SUPPLIER OPTION	INCLUSIVE / EXTRA (Please quote % below) _____ %
5	DEIVERY SCHEDULE	50% of Qty within 30 days from PO date & Balance 50 % by 60 days from PO date	NON DEVIATABLE
6	PAYMENT TERMS	AFTER 45 DAYS FROM THE DATE OF RECEIPT AND ACCEPTANCE OF MATERIALS AT BHEL (For details please read S.No:06 of "Annexure - A")	ACCEPTED / NOT ACCEPTED
7	LD CLAUSE	(For details please read S.No:07 of "Annexure - A")	NON DEVIATABLE
8	RISK PURCHASE CLAUSE	(For details please read S.No:07 of "Annexure - A")	NON DEVIATABLE
9	CONTACT PERSON DETAILS	NAME: MOBILE NO: EMAIL :	
10	ACCEPTANCE FOR SUPPLYING HEX NUTS AS PER STANDARD INDICATED FOR EACH ITEM		CONFIRM / NOT CONFIRM
11	ACCEPTANCE FOR SUPPLYING HEX NUTS AS PER TDC:5:166 REV.04		CONFIRM / NOT CONFIRM

SIGN AND SEAL OF AUTHORIZED PERSON

ANNEXURE –I

Certificate by Chartered accountant on Chartered Accountant's letter head

This is to certify that M/s....., (hereinafter referred to as 'company') having its registered office atis registered under MSMED Act 2006, (Entrepreneur Memorandum No (Part-II) dated: Category: (Micro/Small) (Copy enclosed).

Further verified from the Books of Accounts that the investment of the company as per the latest audited financial year as per MSMED Act 2006 is as follows:

1. **For Manufacturing Enterprises:** Investment in plant and machinery (i.e. original cost excluding land and building and the items specified by the Ministry of Small Scale Industries vide its notification No.S.O 1722 (E) dated October 5, 2006:
Rs..... Lacs
2. **For Service Enterprises:** Investment in equipment (original cost excluding land and building and furniture, fittings and other items not directly related to the service rendered or as may be notified under the MSM ED Act, 2006:
Rs..... Lacs

(Strike off whichever is not applicable)

The above investment of Rs..... Lacs is within permissible limit of Rs..... Lacs for..... Micro/Small (Strike off which is not applicable) Category under MSMED Act 2006.

Or

The company has been graduated from its original category (Micro/Small) (Strike off which is not applicable) and the date of graduation of such enterprise from its original category is..... (dd/mm/yyyy) which is within the period of 3 years from the date of graduation of such enterprise from its original category as notified vide S.O.No. 3322(E) dated 01.11.2013 published in the gazette notification dated 04.11.2013 by Ministry of MSME.

Date:

(Signature)

Name:

Membership number:

Seal of Chartered Accountant:

ANNEXURE - N (For NEW VENDORS only)

SI No	Details	Document submission
1	Nature of ownership & relevant documents. <i>(Proprietorship-Professional Tax Regn & Municipal Regn; Partnership firm – Partnership Deed; Co-operative society – Society rules & bye laws ; Private/Limited Company – memorandum & Articles of Association)</i>	
2	Manufacturing range & facilities: • List down the product range & specification details. • List of Manufacturing facilities/equipment's (including material handling facility)	
3	Licence details of the factory	
4	• Permanent Account No	
5	• Central Sales Tax registration number	
6	• State sales Tax / TIN number	
7	• Excise duty registration number	
8	• Excise control code number	
9	• Service tax registration number	
10	• Regn number of category as per MSMED Act (If applicable)	
11	If registered with any other BHEL unit • Letter of registration with BHEL unit (If applicable) • Proof of successfully executed or executing purchase orders	
12	Accreditation certificate for ISO:9001 / TOC of Quality System manual / ISO:14000 / OHSAS ISO 18000 (If applicable)	



PLANT STANDARD

HPBP TIRUCHIRAPPALLI

BPS 41324

Rev. No. 04

PAGE 1 OF 2

NUTS FOR HIGH TEMPERATURE USE

(For medium of temperature from 525°C to 565°C)

1.0 SCOPE

Covers the requirements of hexagon nuts for use in medium of temperature from 525°C to 565°C and in the size M10 to M95x4.

2.0 SPECIFICATION AND REFERENCE STANDARDS

Dimensions and preferred sizes	Fig 1 & Table 1 of this standard	
Tolerance	Product grade	A for nuts with $d \leq M16$ B for nuts with $d > M16$
	Indian Standard	IS: 1367 :Part 2
Thread	Pitch	Table 1 of this standard
	Tolerance	6H
	Indian Standard	IS 4218: Part 3
Material	Steel to ASTM A194 Gr 7 certified in quenched and tempered condition	
General requirements	Nuts shall comply with TDS:5:166 in respect of requirements not covered in this standard except for cadmium plating.	

2.1 Referred standards (Only current versions are applicable)

IS 1367: Part 2 Technical supply conditions for threaded steel fasteners

IS 4218: Part 3 ISO metric screw threads

ASTM A194 Specification for carbon and alloy steel nuts for bolts for high pressure and high temperature service

TDC:5:166 Carbon & Alloy Steel Nuts to Specification SA 194 Gr2H/2HM/Gr4/Gr7 for Valves, Oil Field Equipment & other applications.

3.0 DESIGNATION

A Grade 'A' hexagon nut to this standard of thread size M10 shall be designated as:

3.1 On Drawings

- i) Material Specification column ASTM A 194 Gr 7
- ii) Description Column HEX NUT GR A T525 - 565 M10
- iii) Drawing Number Column BPS 41324
- iv) Material Code column: 4132400010

Revision 04 Size M64x6 Added			Approved STANDARDS SECTION I.T. SOLUTIONS & SERVICES HPBP, TIRUCHIRAPPALLI		
Rev. No. : 04	Amd. No.	Reaffirmed	Prepared	Issued	Dt of 1st Issue
Dt. 07-08-2015	Dt.	Year	STANDARDS	STANDARDS	FEB 1990

COPYRIGHT AND CONFIDENTIAL
The information on this document is the property of BHARAT HEAVY ELECTRICALS LIMITED. It must not be used directly or indirectly in any way detrimental to the interest of the company.



PLANT STANDARD

HPBP TIRUCHIRAPPALLI

BPS 41324

Rev. No. 04

PAGE 2 OF 2

3.2 Ordering Description

For placing indents, issuing enquiries and on purchase order, Ordering Description given below shall be followed. (Typical examples)

Hex Nut M10 to BPS : 41324-A-ASTM A 194 Gr 7 for sizes upto M16

Hex Nut M30 to BPS : 41324-B-ASTM A 194 Gr 7 for sizes M20 to M30

Hex Nut M36x3 to BPS : 41324-C- ASTM A 194 Gr 7 for sizes M36x3 and above

4.0 ADDITIONAL INFORMATION

4.1 Copies of this standard and TDC: 5:166 shall be enclosed along with the purchase order.

FIG 1 DIMENSIONS FOR HEXAGON NUTS (All dimensions are in millimeters)

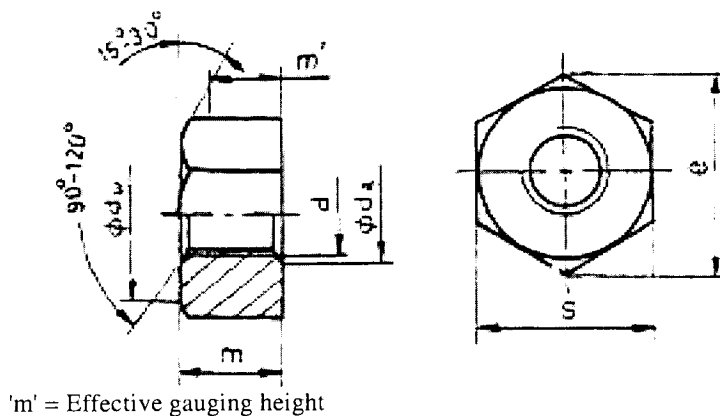

TABLE 1 (All dimensions are in millimeters)

Thread size d	d _a		d _w Min	e		m		M' Min	s		Weight
	Min	Max		Max	Min	Max	Min		Max	Min	
M10	10	10.8	14.6		17.77	10	9.64	7.7	16	15.73	10.8
M12	12	13.0	16.6		20.03	12	11.57	9.3	18	17.73	16.5
M16	16	17.3	22.5		26.75	17.1	16.40	13.1	24	23.67	33.0
M20	20	21.6	27.7		32.95	20.7	19.40	15.5	30	29.16	64.5
M24	24	25.9	33.2		39.55	24.2	22.90	18.3	36	35.0	110.0
(M27)					45.20	27.6	26.30	21.0	41	40.0	166.0
M30	30	32.4	42.7		50.85	30.7	29.10	23.3	46	45.0	231.0
M36x3	36	38.9	51.1		60.79	36.6	35.00	28.6	55	53.8	364.0
(M48x3)					86.5		48	46.40	75	73.8	935.0
M60x4	60	64.8			104		48	47	90	88.6	1625
M72x4	72	77.8			121		72	71	105	103.6	3020
M95x4	95	102.6			190		95	94	164.5	163	12200
M36x4	36	38.9	51.3	60.8	61.02	36	34.40	27.5	55	54	430
M42x4.5	42	45.4	60.8	75.1	72.32	42	40.40	32.3	65	64	810
M48x5	48	51.8	70.3	86.5	83.62	48	46.40	37.1	75	74	1240
M56x4	56	60.5	79.6	98	94.69	56	54.10	43.3	85	83.8	1760
M64x4	64	69.1	88.5	110	105.2	54	52.10	41.7	95	93.1	2460
(M64x6)	64	69.1	88.5	110	105.2	54	52.10	41.7	95	93.3	2460

NOTE:

- Sizes in brackets are non-preferred
- Weights are given in Kg per 1000 numbers only

QUALITY ASSURANCE

QA:3.2.1:003:99

Date:09-02-99

Sub: Release of revised TDC:5:166/04 TDC for Carbon & Alloy steel nuts to specn SA 194 Gr 2H/2HM/Gr4/Gr7 for Valves, Oil field equipments & other applications.

Please find enclosed the subject TDC for your official use and record.

(K.Rangachari)
SR.MANAGER/QA

Distribution:

DGM/Valves/Matl Plng/Bldg 6...Sri.R.Prabudoss
DGM/Spares/Matl Plng/Bldg 53...Sri.K.Y.Prabu
DGM/Matl Plng/Bldg 2&4.....Sri.V.Balakrishnan
SM/Purchase/Valves.Bldg 24....Sri.Sam Manohar Nayagam
SM/Purchase/FB/Bldg 24..... Sri.P.Namasivayam
SM/QC (Proc)/Bldg 2&4.....Sri.G.Mathivanan
M/Engg/Valves/Bldg.6.....Sri.K.Nagarajan
Master file

BHEL - Quality Assurance Department. TECHNICAL DELIVERY CONDITION

TDC:5:166 Rev.No.:04 Effective Dt.:13/01/99

Page 1

CARBON & ALLOY STEEL NUTS TO SPECN SA 194 Gr2H/2HM/Gr4/Gr7
for VALVES,OIL FIELD EQUIPMENT & OTHER APPLICATIONS**Revision record:**

Rev:00/11.04.90 : First issue

Rev:01/21.06.90 : Editorial corrections

Rev:02/21.04.91 : TC for nuts added

Rev:03/20.10.96 : NDT,Acid pickling added & rewritten

Rev:04/13/01/99 : Studs/bolts changed as nuts in Cl.5,7.1,7.2

1.0 MATERIAL SPECIFICATION - SA 194 Gr2H/Gr2HM/Gr4/Gr7{latest on date of Purchase Order (P.O)}

2.0 GENERAL

This TDC is applicable for API 6A applications including NACE MR-01-75 cl.II & cl.III also. Shall be manufactured to the relevant drawing and P.O.requirements.

Nuts shall be hot/cold forged or manufactured from hot rolled/cold drawn bars. If made from hexagonal bars, 100% MT is to be done on bars. If made from round bars, the bars shall be machined to remove 2mm from surface, (ie 4mm in dia) to remove all surface defects. Atleast 10% of the machined bars shall be MT tested to ensure that the surface defects are fully removed.

Nuts shall be heat treated to meet the requirements of SA194 only in a salt bath, or controlled atmosphere furnace. After HT the threads shall be thoroughly cleaned to remove all deposits. When acid pickling is done for cleaning it shall be done as per Cl 7.3.

Cadmium plating as per (Cl 7.1) if specified in drg/P.O. or rust preventive fluid coating as per (Cl 7.2) shall be done.

3.0 CHEMICAL & MECHANICAL PROPERTIES

Mill certificate for chemical composition from steel manufacturer for conformance to the specification heat-wise. Additionally, product analysis shall be done for one piece/heat by the nut manufacturer.

HARDNESSFor SA194 2H, Gr4, & Gr7

Hardness check on finished nut as per SA194, using sampling plan (Cl.7.4).Hardness in the finished nut shall be 24 to 35 HRC or 248 to 352 BHN.

For SA194 Gr2HM:

Hardness check on 100% of nuts.Hardness must be within 159 to 237 BHN.

Proof load test shall be done as per SA194 for all grades.

After final heat treatment, sample nuts shall be heat treated as below and meet the corresponding hardness requirements.

Grade	Temp	Time	Cooling	Hardness at room temp.
2H	540°C	24Hrs	Slow cool	179 BHN (min)
2HM	540°C	-do-	Slow cool	159 BHN (min)
Gr4/Gr7	590°C	-do-	Slow cool	201 BHN (min)

CONE STRIPPING TEST: This test shall be performed as per SA194 in case of visible surface discontinuities.On such cases Proof load shall be as per ASTM A194 (latest std).

4.0 FINAL INSPECTION

All inspection shall be as per drawing and SA194.

The threads shall be checked with calibrated plug gauge in the final heat-treated condition for black variety and in final plated condition for the plated variety.

Visual and Dimensional checks in the finished nuts and their acceptance shall be as per IS 2614 Table-I(latest).

5.0 MARKING & PACKING

Punch/emboss each finished nuts with material grade (2H/2HM/Gr4/Gr7); supplier's emblem.

Punch/emboss Sl.no also in 2HM nuts in addition to the above to co-relate with hardness. In addition, the grade symbol shall be underlined.

Pack in wooden box of convenient size for easy handling & transportation.Mark quantity in each box.

6.0 CERTIFICATION

The manufacturer shall provide TC (ref. page 3) duly countersigned by the Authorised Inspecting Authority nominated by BHEL in P.O. (if specified) along with Raw Material TC from Steel Maker. Manufacturer's TC shall contain P.O.No.heat no., Chem & Mech properties, HT parameters, surface coating with coating thickness, baking details and certify soundness & confirmation to P.O. requirements.

7.0 SPECIAL REQUIREMENTS

7.1 CADMIUM PLATING REQUIREMENTS

Clean the nuts to make it free from rust, grease, oil, scale, etc., before plating. When pickling is considered essential, it shall be done as per Cl 7.3. Apply Cadmium Plating to the specified thickness on specified areas. After plating, Bake the parts at 175 Deg.C to 205 Deg.C for a minimum period of 3 hours. The elapsed time between plating and baking shall not exceed 8 hours. Apply a Chromate Conversion coating after plating and baking.

7.2 RUST PREVENTIVE COATING REQUIREMENTS

Clean the nuts to make it free from rust, grease, oil, scale, etc., before applying protective coating. When pickling is considered essential it shall be done as per Cl 7.3. One coat of rust preventive fluid of any of the following vendors shall be applied.

CHEMICAL

VENDOR

1. BONITA-RPF M/s Bonita Chemicals, 64, Industrial Estate, Nunhai, Agra-282 006.
2. CHAMPION-RPF M/s Guardian Chemicals, 8, Rajaji Ind st, West Lake Area, Nungambakkam, Madras-600 034
3. ECONOL RPF M/s Process Aids, Bangalore
(non-drying type)
4. TECTYL 506 M/s Plastipeel Chemicals and Plastics (P) Ltd, Thane-400 604
5. TRPF M/s Sundaram Paints Pvt. Ltd., Thanjavur-613 004
6. TRPF M/s Solar Paints, Pudukkotai.
7. WICOR-P M/s Western India Paint and Color Co P. Ltd, Madras-600 017

7.3 ACID PICKLING

When pickling is considered essential for cleaning, it shall be done using Hydrochloric acid of 5 to 10% acid concentration at 50 deg C with inhibitor. The concentration and type of inhibitors shall be as recommended by any of the following vendors. 1) M/s Agromore Ltd. Bangalore. 2) M/s Prosol Corporation, Hyderabad. 3) M/s Guardian Anti-corrosives, Madras. 4) M/s Mascat Chemicals, Bombay. After pickling thorough rinsing shall be carried out with water to remove acid residues. Immediately after pickling, the components shall be dried and baked at 175 to 205 deg C for 3hours before taking up the next operation.

7.4 SAMPLING PLAN FOR HARDNESS CHECK AFTER HT

The following double sampling plan shall be used. Hardness values shall be 25 to 34 HRC after HT. IS 2500 (Double Sampling) Normal Inspection, Level 2.

No. of Pieces in the lot	Acceptable Quality Level (2.5%)							
	First sample number (n1)		Acceptance number (Ac)	Reject numbers (Rc)	Second sample number (n2)	Combined sample number (n1+n2)	Acceptance number (Ac)	Rejection number
0 - 500	32	1	4	32	64	4	5	
501 - 1200	50	2	5	50	100	6	7	
1201 - 3200	80	3	7	80	100	8	9	
3201 - 10000	125	5	9	125	250	12	13	
10001 - 35000	200	7	11	200	400	18	19	

Ac:-Acceptance number: Max. no. of defectives allowed in the sample for the acceptance of the lot.

Rc:-Rejection number: Min.no. of defectives in the sample resulting in the lot's rejection.

PROCEDURE FOR OPERATING THIS PLAN : Suppose the lot size is 1,000. From table chose the class, which includes 1,000 viz 501 - 1200. Hence, use the sampling plan given against this class. Take a sample of 50 pieces and test for hardness.

TEST CERTIFICATE FOR NUTS - SAMPLE FORMAT

TC NO: _____ DATE: _____

CUSTOMER : _____ P.O.NO: _____ Dt: _____
 D.C.NO: _____ Dt: _____
 Specn : _____

PRODUCT : _____
 SIZE OF BAR USED: _____
 RAW MATL.TC NO: _____ TDC NO: _____
 HEAT NO.: _____ DRG NO: _____
 LOT NO: _____ Thread specn: _____
 QUANTITY: _____

CHEMICAL COMPOSITION (%) :

C	Si	Mn	P	S	Cr	Ni	Others

HEAT TREATMENT:

HARDENING: TEMP: _____ Deg.C; SOAKING TIME: _____ Minutes; COOLING MEDIUM: _____
TEMPERING: TEMP: _____ Deg.C. SOAKING TIME: _____ Minutes; COOLING MEDIUM: _____
 BAKING TEMP : _____ Deg.C. BAKING TIME: _____ Minutess.

MECHANICAL TESTING:

HARDNESS AFTER HT (MIN & MAX) : _____ BHNNO OF SAMPLES
 HARDNESS AFTER 24 HRS TEMPERING ON SAMPLE NUT : _____ BHN
 PROOF LOAD APPLIED : _____ Kgf
 CONE PROOF LOAD TEST : _____ LOAD APPLIED: _____



MAGNETIC TESTING (IN PROCESS) :

FINAL INSPECTION (VISUAL) :

SURFACE COATING : _____ COATING THICKNESS : _____ Micr
 IDENTIFICATION :

It is certified that the above results are correct and the parts are as per specification & P.O. requirements.

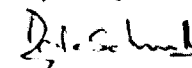
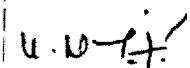
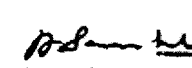
Signature
 Incharge of Quality

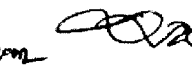
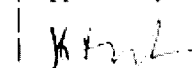
Prepared by	REVIEWED BY			Approved by
 R. Rajasekar	 K. Nagarajan	 Sam Monohar Nayagam	 G. Mathivanan	 P. Vasudevan
Qual Assurance	Engg/Valves	Purchase/Valves	Quality Control	Quality assurance
				 K. Rengachari Qual Assurance