

REQUEST FOR QUOTATION

	BHARAT HEAVY ELECTRICALS LIMITED Electronics Division PB No. 2606, Mysore Road Bangalore - 560026 INDIA	RFQ NUMBER: IRNBOS0001 RFQ DATE : 09.SEP.2015	Due Date 23.SEP.2015 Time: 13:00 HRS VENUE : NEW ENGG. BLDG
MMI:PU:RF:003			

	(for all correspondence) Purchase Executive : ISWARYA RAVEENDRAN Phone : Fax : E-mail: iswarya@bheledn.co.in
--	--

Please submit your lowest quotation subject to our terms and conditions attached for the material mentioned below. The quotation must be enclosed in a sealed envelope / Fax superscribed with RFQ no. and due date, should reach us on or before the due date by **13.00** hours IST and will be opened on the same day at **13.30** hours at the venue mentioned above. **PLEASE DROP THE OFFER IN THE BOX PROVIDED AT RECEPTION.**

1. Bid has to be submitted as Two Part - in two sealed covers-Techno Commercial Bid(Part-1) & Price Bid (Part-II)- clearly written on each cover both put in a single sealed envelope super-scribed with RFQ No. and Due date.
2. Annexures B (Commercial Compliance-Indian) & B1 (Unpriced Bid) to be submitted along with Technical Bid (Part-1) & Annexure B2 to be submitted along with Price Bid (Part-II).
3. Kindly quote only the basic rates. Taxes will be considered extra.
4. Kindly quote on FOR SITE basis.
5. Delivery Date mentioned in RFQ is tentative. Actual Requirement is as below:
 Supply : 6 weeks from sample approval.
 Sample submission : 10 days from PO date.
6. Warranty : 18 months from Supply date or 12 months from commissioning date whichever is earlier.
7. Quantity sharing : The Order Quantity Share of 60:40 will be procured from 2 vendors at L1 matched price. L1 will be offered 60% of total quantity. Balance 40% will be offered to L2 at L1 matched price. If L2 does not accept L1 price, the same offer will be made to L3, L4, L5, soon.
 If none of the vendors agree to match L1 rate, full quantity will be placed on L1 vendor.
 In the event of L1 vendor not meeting the delivery commitment, the undelivered quantity will be offered to L2 and vice versa with the same terms and conditions.
8. For any other Terms and Conditions, kindly refer to the following:
 A: Instructions to Bidders (Doc Ref : SCPV: BOS: 001-Rev 00)
 B: General Commercial Conditions for Contract (Doc Ref : SCPV: BOS: 002-Rev 00)
 C: Annexures

SI No.	Description	Qty	Unit	Delivery qty	Delivery Date
1	PS0679059997 Module Mounting structure - Purlin as per drawing No 16790500063 , Weight of each purlin is 0.38 MT. Test Certificate	280	ST	280	30.DEC.2015
2	PS0679060006 Module Mounting structures - Grider as per drawing No 16790500064 , Weight of each Grider is 0.318 MT. Test Certificate	280	ST	280	30.DEC.2015
3	PS0679060014 Module Mounting structures - SS Hardware- M6X20 , Total Weight is 0.4 MT Test Certificate	1	ST	1	30.DEC.2015
4	PS0679060022 Module Mounting structures - Misc items as per drawing no 16790500065 , Total weight is 29 MT Test Certificate	1	ST	1	30.DEC.2015

For and On behalf of BHEL.

Page 1 OF 2

REQUEST FOR QUOTATION

 MMI:PU:RF:003	<p style="text-align: center;">BHARAT HEAVY ELECTRICALS LIMITED Electronics Division PB No. 2606, Mysore Road Bangalore - 560026 INDIA</p>	<p>RFQ NUMBER: IRNBOS0001</p> <p>RFQ DATE : 09.SEP.2015</p>	<p style="text-align: center;">Due Date 23.SEP.2015 Time: 13:00 HRS</p> <p style="text-align: center;">VENUE : NEW ENGG. BLDG</p>
		<p style="text-align: center;">(for all correspondence)</p> <p>Purchase Executive : ISWARYA RAVEENDRAN Phone : Fax : E-mail: iswarya@bheledn.co.in</p>	
<p>Please submit your lowest quotation subject to our terms and conditions attached for the material mentioned below. The quotation must be enclosed in a sealed envelope / Fax superscribed with RFQ no.and due date, should reach us on or before the due date by 13.00 hours IST and will be opened on the same day at 13.30 hours at the venue mentioned above. PLEASE DROP THE OFFER IN THE BOX PROVIDED AT RECEPTION.</p>			
<p>Total Number of Items - 4</p>			
<p>Please note that the tender will be opened in the presence of the bidders or his authorised representatives (maximum two per organisation) who choose to be present with authorisation letters. Refer annexure for the terms and conditions.</p> <p>Please specify Terms of delivery, Excise duty, sales tax, Ex-BHEL, Ex-works surcharge, Insurance,P&F, Freight and other taxes very clearly . For evaluation,exchange rate(TT selling rate of SBI) as on scheduled date of tender opening (Part-I bid incase of two part bid) shall be considered. The offers of the bidders who are on the banned list as also the offer of the bidders, who engage the services of the banned firms, shall be rejected.The list of banned firms is available on BHEL web site www.bhel.com</p>			
<p>i). This is only RFQ not an order. ii). In all correspondence quote RFQ No. & due date. iii). In Quotation BHEL material code / RFQ Sl. No. should be mentioned clearly. iv). Quotation Envelope / Fax not superscribed with RFQ No.and due date is liable for rejection. v). Quotation should remain valid for a minimum peiod of 90 days from due date. vi). In case of non-receipt of Quotation or regret letter for 3 consecutive RFQs you are liable to be removed from our vendors list. vii). All Prices should be written in words and numbers. viii). Excise Chapter Heading should be mentioned for all items where VAT is applicable .</p>			

For and On behalf of BHEL.

COMMERCIAL TERMS & CONDITIONS (Indigenous vendors)				
RFQ No.IRNBO0001 Dt.09.09.2015 : Due Date(Tech Bid) : 23.09.2015				
Sl No.	Terms	BHEL Term	Confirmation	Deviation / Remarks
1	Bidding	(a) Bid has to be submitted as Two Part – in two sealed covers- Techno Commercial Bid(Part-1) & Price Bid (Part-II)- clearly written on each cover both put in a single sealed envelope super-scribed with RFQ No. and Due date.	Agree / Not agree	
		(b) Annexures B & B1 to be submitted along with technical bid (Part-1) & Annexure B2 to be submitted along with Price bid (Part-II).	Agree / Not agree	
		(c) Clause-wise compliance to BHEL Purchase specification along with all documents as called in Technical specification to be submitted along with technical bid(Part-1).	Agree / Not agree	
		(d) All documents as per PQC to be submitted along with Technical Bid.	Agree / Not agree	
2	Price Basis	Firm i.e., from the date of PO to completion of supply (PVC clause not acceptable).	Agree / Not agree	
3	Terms of Delivery	Free On Road Basis to Project Site : Bhimavaram, Andhra Pradesh	Agree / Not agree	
4	Delivery Period	Supply : 6 weeks from sample approval Sample submission : 10 days from PO date	Agree / Not agree	
5	Payment Terms	100% of Basic value with taxes, duties and freight will be paid with 45 days credit from the receipt of material or 15 days credit from the date of submission of complete set of documentation whichever is later)+ submission of PBG for 10% of basic PO value valid for Warranty Period+6 months Claim Period from BHEL Consortium Bank ,if applicable. Note: If PBG cannot not be submitted, vendors can also accept for the final 10% payment, payable after the warranty period + 6 months of claim period against supplementary invoice subject to the completion of commissioning as PBG is linked to Warranty period.	Agree / Not agree	
		For any deviation in payment term, the offer will be liable for loading as per Clause G of ITB,(Doc Ref : SCPV: BOS: 01-Rev 00)	BHEL	
6	Excise Duty	(a) To confirm whether applicable. If applicable, indicate prevailing rate of Excise duty.	Applicable / Not applicable	Prevailing rate of Excise duty : %
		(b) BHEL is trying to avail Customs Duty & Excise duty exemption through MNRE. Successful bidder shall support with all relevant documents failing which ED shall not be reimbursed.	Agree / Not agree	
7	Sales Tax	(a) To confirm whether applicable. If applicable, indicate prevailing rate of Sales Tax against Form C.	Applicable / Not applicable	Prevailing rate of Sales Tax : %
		(b) For issue of form "C", vendor has to furnish "E1/E2" form.Please confirm that "E1/E2 Sale form" will be submitted.	Applicable / Not applicable	
		(c) Wherever E1/E2 transactions are made, CST paid by sub vendor will not be reimbursed (As it is input cost to vendor)	Agree / Not agree	
8	Value Added Tax	Both are in the same State, VAT is applicable please indicate VAT applicable.	Applicable / Not applicable	Prevailing rate of VAT : %
9	Octroi	To confirm whether applicable, if applicable indicate current rate of Octroi. If Applicable, the same will be in BHEL scope	Complied	Octroi _____%

Vendor's signature WITH SEAL

COMMERCIAL TERMS & CONDITIONS				
RFQ No.IRNBS0001 Dt.09.09.2015 : Due Date(Tech Bid) : 23.09.2015				
SI No.	Terms	BHEL Term	Confirmation	Deviation / Remarks
10	Service Tax	To confirm whether applicable, if applicable indicate current rate of Service Tax.	Not applicable	Prevailing rate of Service Tax %
		Furnish following : Service Tax Regn. No. Confirmation that Service Tax register is maintained.	Not applicable	Service Tax Regn. No.....
11	Evaluation of L1 vendor	Over all L1 of Supply on "FOR" basis to Bhimavaram Site will only be considered.	Agree / Not agree	
12	Warranty	18 months from Supply date or 12 months from commissioning date whichever is earlier.	Agree / Not agree	
13	Pre Shipment Inspection	Pre Shipment Inspection will be carried out by BHEL/Customer for which test report shall be sent one week in advance.	Agree / Not agree	
14	Penalty	(a) Penalty of 0.5% per week at the basic price of the good for undelivered quantity of supply portion, subject to a maximum of 10%. For Supply, Pre Shipment Inspection Call Letter Date (Receipt of test report) will be treated as delivery for purpose of penalty.	Agree / Not agree	
		(b)For any deviation in penalty term, the offer will be liable for loading as per Clause No. G, Point No.(b) of ITB (Doc Ref : SCPV: BOS: 01-Rev 00)	Agree / Not agree	
15	Road Permit	Road permit if applicable will be given by BHEL before Dispatch of ordered Items	BHEL	
16	Despatch Documents	Complete set of despatch documents in 3 sets shall be forwarded to BHEL directly. Despatch documents include Commercial Invoice, Excise Invoice (if ED is applicable), Lorry receipt (L/R), MRC, Packing list, Warranty certificate, Original Performance Bank Guarantee (Directly from issuing bank to BHEL), One set of Invoice, Packing list and L/R shall be faxed immediately after despatch to BHEL-EDN, Bangalore.	Complied	
17	Other terms & conditions	For any other Terms and Conditions, kindly refer to the following: A: ITB (Doc Ref : SCPV: BOS: 01-Rev 00) B: GCC (General Conditions of Contract) C: Annexures	Agree / Not agree	
18	Reverse Auction	BHEL reserves the right to conduct Reverse Auction. Procedure for the same will be informed by BHEL .	Agree / Not agree	
19	Shipment	Kindly indicate the state from where the shipment will take place	State/Place	
20	Splitting of order	The Order Quantity Share of 60:40 will be procured from 2 vendors at L1 matched price. L1 will be offered 60% of total quantity. Balance 40% will be offered to L2 at L1 matched price. If L2 does not accept L1 price, the same offer will be made to L3, L4, L5, so on. If none of the vendors agree to match L1 rate, full quantity will be placed on L1 vendor. In the event of L1 vendor not meeting the delivery commitment, the undelivered quantity will be offered to L2 and vice versa with the same terms and conditions.	Agree / Not agree	
21	Validity	Quotation should remain valid for a period of 90 days from the due date	Agree / Not agree	
22	PBG	(a)PBG shall be furnished in the BHEL prescribed format. (b) Deviation if any Please specify	Agree / Not agree	
23	MSE Vendor	(a) Kindly indicate if MSE vendor	(a) MSE / Non MSE	
		(b) If MSE vendor, documents as called in Annexure VII enclosed	(b) Documents enclosed	

Vendor's signature with seal

TECHNICAL BID ENCLOSURE FOR COMPLIANCE OF QUOTE : UNPRICED BID (Indigenous Vendors)									
RFQ No.IRNBOS0001 Dt.09.09.2015 : Due Date(Tech Bid) : 23.09.2015									
SI No.	Material Code	DESCRIPTION	QUOTED	QTY	UNIT	TAXES			Remarks
						ED %	CST%	VAT %	
1	PS0679059997	Module Mounting structure - Purlin as per drawing No 16790500063	YES/NO	280	ST				Taxes Extra
2	PS0679060006	Module Mounting structures - Grider as per drawing No 16790500064	YES/NO	280	ST				Taxes Extra
3	PS0679060014	Module Mounting structures - SS Hardware- M6X20	YES/NO	1	ST				Taxes Extra
4	PS0679060022	Module Mounting structures - Misc items as per drawing no 16790500065	YES/NO	1	ST				Taxes Extra
5	**Freight Charge including Service Tax on Freight		YES/NO	Lumpsum		NA	NA	NA	**Freight : Included/Extra
6	**Insurance		YES/NO	Lumpsum		NA	NA	NA	**Insurance : Included/Extra

Note:

1. The quoted prices shall be on "FOR" basis to project site: Bhimavaram,AP
2. Please indicate taxes : ED,VAT/CST clearly applicable as on date.
3. Use this format for compliance(reproducing on your letter head is acceptable).
4. Taxes will be considered extra for supply. Please quote only the basic rates.
5. **Indicate whether freight charge & insurance charge is included in quoted rate or will be charged extra.In absence of clarity, quoted rate will be considered as inclusive of freight & insurance charges.(If the offer contains the freight value at actuals, it will be considered as all inclusive).
6. BHEL is trying to get concession on Excise Duty under supply for solar power project. At the time of clearance of goods we may issue exemption certificate.In such case, ED will be exempted but not reimbursed. At present, please quote with applicable rate without concession of ED for comparison.

AUTHORISED SIGNATORY WITH SEAL

PRICE BID										
RFQ No.IRNBOS0001 Dt.09.09.2015 : Due Date(Tech Bid) : 23.09.2015										
Sl No.	Material Code	DESCRIPTION	QTY	UNIT	Unit Rate (Rs.)	Total Value (Rs.) (Rate X Qty)	TAXES			Remarks
							ED %	CST%	VAT %	
1	PS0679059997	Module Mounting structure - Purlin as per drawing No 16790500063	280	ST						Taxes Extra
Unit Rate in words :										
2	PS0679060006	Module Mounting structures - Grider as per drawing No 16790500064	280	ST						Taxes Extra
Unit Rate in words :										
3	PS0679060014	Module Mounting structures - SS Hardware- M6X20	1	ST						Taxes Extra
Unit Rate in words :										
4	PS0679060022	Module Mounting structures - Misc items as per drawing no 16790500065	1	ST						Taxes Extra
Unit Rate in words :										
5	**Freight Charge including Service Tax on Freight		Lumpsum				NA	NA	NA	**Freight : Included/Extra
Freight charge in words :										
6	**Insurance		Lumpsum				NA	NA	NA	**Insurance : Included/Extra
Insurance charge in words :										

Note:

1. The quoted prices shall be on "FOR" basis to project site: Bhimavaram,AP
2. Please indicate taxes : ED,VAT/CST clearly applicable as on date.
3. Use this format for compliance(reproducing on your letter head is acceptable).
4. Taxes will be considered extra for supply. Please quote only the basic rates.
5. **Indicate whether freight charge & insurance charge is included in quoted rate or will be charged extra.In absence of clarity, quoted rate will be considered as inclusive of freight & insurance charges.(If the offer contains the freight value at actuals, it will be considered as all inclusive).
6. BHEL is trying to get concession on Excise Duty under supply for solar power project. At the time of clearance of goods we may issue exemption certificate.In such case, ED will be exempted but not reimbursed. At present, please quote with applicable rate without concession of ED for comparison.

LIST OF INTERNATIONAL AIRPORTS

Sl. No	Country	Air Ports
1	Austria	Vienna, Linz, Graz
2	Australia	Sydney, Melbourne, Perth
3	Belgium	Antwerp, Brussels
4	Canada	Toronto, Montreal
5	China	Shanghai
6	Cyprus	Lamaca
7	Czech Republic	Prague (Via Frankfurt)
8	Denmark	Copenhagen
9	Egypt	Cairo
10	Finland	Helsinki
11	France	Paris (Rossy), Lyon
12	Germany	Darmstadt, Manheim, Nurnberg, Hamburg, Stuttgart, Munich, Koln, Dusseldorf & Hannover, Frankfurt, Berlin
13	Hong Kong	Hong Kong
14	Italy	Rome, Milan, Turin, Bologna, Florence
15	Ireland	Dublin
16	Israel	Telaviv
17	Japan	Tokyo, Osaka
18	Malaysia	Kuala lumpur, Penang
19	Netherlands	Amsterdam, Rotterdam
20	New Zealand	Auckland
21	Norway	Oslo
22	Oman	Muscat
23	Philippines	Manila
24	Romania	Bucharest
25	Russia	Moscow
26	Saudi Arabia	Riyad
27	Singapore	Singapore
28	Slovakia	Bartislowa
29	South Africa	Johannesburg, Durban
30	South Korea	Kimpo
31	Spain	Barcelona
32	Sweden	Stockholm, Gothenburg, Milano
33	Switzerland	Basle, Zurich, Geneva
34	Taiwan	Taipei
35	U.A.E.	Dubai
36	U.K.	Landon (Heathrow), Newcastle, Oxford, Cheltham, Bristol, Welling borough, Birmingham, East Midland, Manchester, Leeds, Glasgow.
37	U.S.A.	New York, Chicago, San Francisco, Los Angeles, Atlanta
38	Ukraine	Kiev

Terms & Conditions of Reverse Auction

Against this enquiry for the subject item/ system with detailed scope of supply as per enquiry specifications, BHEL may resort to "REVERSE AUCTION PROCEDURE" i.e., ON LINE BIDDING (THROUGH A SERVICE PROVIDER). The philosophy followed for reverse auction shall be English Reverse (No ties).

- (1) For the proposed reverse auction, technically and commercially acceptable bidders only shall be eligible to participate.
- (2) Those bidders who have given their acceptance for Reverse Auction (quoted against this tender enquiry) will have to necessarily submit 'online sealed bid' in the Reverse Auction. Non-submission of 'online sealed bid' by the bidder for any of the eligible items for which techno-commercially qualified, will be considered as tampering of the tender process and will invite action by BHEL as per extant guidelines in vogue.
- (3) BHEL will engage the services of a service provider who will provide all necessary training and assistance before commencement of on line bidding on internet.
- (4) In case of reverse auction, BHEL will inform the bidders the details of Service Provider to enable them to contact & get trained.
- (5) Business rules like event date, time, bid decrement, extension etc. also will be communicated through service provider for compliance.
- (6) Bidders have to fax the Compliance form (annexure IV) before start of Reverse auction. Without this, the bidder will not be eligible to participate in the event.
- (7) In line with the NIT terms, BHEL will provide the calculation sheet (e.g., EXCEL sheet) which will help to arrive at "Total Cost to BHEL" like Packing & forwarding charges, Taxes and Duties, Freight charges, Insurance, Service Tax for Services and loading factors (for non-compliance to BHEL standard Commercial terms & conditions) for each of the bidder to enable them to fill-in the price and keep it ready for keying in during the Auction.
- (8) Reverse auction will be conducted on scheduled date & time.
- (9) At the end of Reverse Auction event, the lowest bidder value will be known on auction portal.
- (10) The lowest bidder has to fax/e-mail the duly signed and filled-in prescribed format for price breakup including that of line items, if required, (Annexure VII) as provided on case-to-case basis to Service provider within two working days of Auction without fail.
- (11) In case BHEL decides not to go for Reverse Auction procedure for this tender enquiry, the Price bids and price impacts, if any, already submitted and available with BHEL shall be opened as per BHEL"s standard practice.
- (12) Bidders shall be required to read the "Terms and Conditions" section of the auctions site of Service provider, using the Login IDs and passwords given to them by the service provider before reverse auction event. Bidders should acquaint themselves of the „Business Rules of Reverse Auction", which will be communicated before the Reverse Auction.
- (13) If the Bidder or any of his representatives are found to be involved in Price manipulation/ cartel formation of any kind, directly or indirectly by communicating with other bidders, action *as per extant BHEL guidelines*, shall be initiated by BHEL and the results of the RA scrapped/ aborted.
- (14) The Bidder shall not divulge either his Bids or any other exclusive details of BHEL to any other party.
- (15) In case BHEL decides to go for reverse auction, the H1 bidder(s) (whose quote is highest in online sealed bid) may not be allowed to participate in further RA process.

PERFORMANCE BANK GUARANTEE
(FOR FOREIGN PURCHASE ORDERS)
BANK NAME AND ADDRESS

Bharat Heavy Electricals Limited (BHEL),
 Electronics Division,
 PB No. 2606,
 Mysore Road,
 BANGALORE- 560 026
 INDIA
 Dear Sirs,

Ref: CONTRACT PERFORMANCE GUARANTEE.

WHEREAS you have entered into a contract reference No PO NO. _____ with M/s _____ having its registered office at _____ for the supply of _____ as detailed in your purchase order No. _____ which is hereinafter referred to as "the said contract" and WHEREAS M/s _____ has undertaken to produce a Bank Guarantee for 10% (Ten Percent) of _____ the contract price amounting to _____ (_____) to secure its obligations to Electronics Division, BHEL having its registered office at New Delhi for the performance of the contract including the warranty of the equipment supplied, We _____ Bank _____ hereby expressly, irrevocably and unreservedly undertake and guarantee as principal obligors on behalf of M/s _____ that in the event Bharat Heavy Electricals Ltd. (B.H.E.L.) declares to us in writing that M/s _____ has not fulfilled any obligation according to the contractual obligation of the said contract, to pay you on demand and without demur to Bharat Heavy Electricals Ltd., Electronics Division , Mysore Road, P.B.No. 2606, Bangalore-560 026, India an amount of _____ (in words _____) subject to as may be determined below:

- 1) Notwithstanding any right M/s. _____ may have directly against you or any disputes raised by M/s _____, Your written demand shall be conclusive evidence to us that repayment is due under the terms of the said contract and shall be binding on us.
- 2) We shall not be discharged or released from this undertaking and Guarantee by any arrangements, variations made between you and M/s. _____ with or without our consent and Knowledge or by any alterations in the obligations of M/s. _____ by any forbearance whether as to payment, time, performance or otherwise.
- 3) This guarantee shall remain valid until the end of twenty-four weeks after the close of the warranty period or until the same is reported by BHEL to us whichever is earlier.
- 4) We agree and undertake not to revoke this guarantee during its validity unless discharged in writing by you subject to the provision of clause (7) below.
- 5) This guarantee shall be a continuing guarantee subject to the foregoing and shall not be discharged by any change in the constitution of the Bank or M/s. _____.
- 6) This guarantee shall be governed by and constructed in accordance with the Laws of India.
- 7) At any time _____ Bank may render this guarantee null and void by paying to Bharat Heavy Electricals Ltd. the full amount being _____ (in words _____)

Note:

- (1) To be executed in Non-Judicial stamp paper by any authorized Indian Bank.
- (2) To be submitted directly by banker to concerned executive in purchase dept., Please give BHEL address to banker.
- (3) Do not enclose with Bank document.
- (4) Any Modification & omissions to this are not permitted

PERFORMANCE BANK GUARANTEE
(FOR INDIGENOUS PURCHASE ORDERS)

THIS DEED OF GUARANTEE made and executed on the _____ day of _____ (year), by the _____ (Bank), registered under the Companies Act 1956/Nationalized Bank constituted under the Banking Companies (acquisition and transfer of undertakings) Act constituted under the State Bank of India Act / Subsidiary Banks Act, having its registered / head office at _____ represented herein by its Branch Manager / authorized representative Sri. _____ & Sri. _____ (Hereinafter called 'guarantor' which term shall mean and include its successors and assigns)

IN FAVOUR OF BHARAT HEAVY ELECTRICALS LIMITED

_____ (Buyer's Name), a company registered under the companies Act, 1956 having its registered office at BHEL House at Siri Fort , New Delhi -100 049 and its Electronics Division at Mysore road, Bangalore-26 (hereinafter referred to as the 'Company' Which term shall include its successors and assigns):

Whereas the company has placed an order on _____ (State the name of _____ the company / firm and its address) (hereinafter referred to as the 'Supplier' which term shall mean and include its liquidators, successors and assign) for the supply of system under order / Contract No. _____ Dt. _____

AND WHEREAS the supplier has agreed to supply the materials and carryout the works as detailed and in accordance with the terms set out in the said order/contract.

AND WHEREAS the company is not required to pay to the supplier a sum of Rupees _____ being the 10% of the value of the goods supplied / Works performed / Services rendered under the said order / contract between the supplier and the company, till the company is satisfied with the mechanical Warranties and the performance standards stipulated in the said order / contract between the company and the supplier has been duly fulfilled, except against a Bank Guarantee for the said sum of Rs _____ in favour of the company by reputed Bank, in which case the company has agreed to make payment to the supplier of the said sum of Rupees _____ being (...%) of the value of the goods supplied / Works performed / Services rendered under the agreement between the supplier and the company and the Guarantor has at the request of the supplier, agreed to furnish this Guarantee subject to the terms and conditions stated below:

NOW THIS DEED WITNESSES THAT IN pursuance of the above said agreement, the guarantor hereby agrees and covenants With company is as follows :-

- 1) That during the period this contract of Guarantee remains effectual, the guarantor shall be liable in respect of the amount due and owing to the company in respect of the payments to the extent of Rs _____ (in words) _____ against any loss or damage caused to or suffered by the company by reasons of any breach of the terms of the said order / contract / Agreement by the supplier.
- 2) The Guarantor hereby undertakes to pay the amounts due and payable under this guarantee without any demur, merely on demand from the company intimating that the amount claimed is due by way of loss or damage caused to or suffered or would be caused or suffered by the supplier of any terms contained in the said order / contract. Any such demand made on the guarantor shall be conclusive as regards the amount due and payable by the Guarantor irrespective of the fact whether the Contractor / supplier admits or denies.
- 3) The Guarantor further agrees that the agreement herein contained shall remain in force and effect till all the supplies to be made / Works to be performed / Services to be rendered under the said order / contract / agreement are completed to the entire satisfaction of the company or till company certifies that the terms and conditions of the said order / contract / agreement have been fully and properly carried out by the said supplier and accordingly discharges the Guarantee. Unless a demand or claim under this guarantee is made on the guarantor in writing on or before the expiry of claim period indicated in clause 6 below, the guarantor shall be discharged from all the liability under this guarantee thereafter.
- 4) The guarantor further agrees with the company that the company shall have the fullest liberty without the consent of the guarantor and without effecting in any manner the obligations of the guarantor hereunder to vary

any of the terms of the said order / contract / agreement or extend the time of performance by the said supplier from time to time or refrain from exercising the power exercisable by the company against the said supplier or to forebear or omit to enforce any of the terms and conditions relating to the said order / contract / agreement, and the guarantor shall not be relieved of its liability in whole or in part , by reason of any act, commission or forbearance on the part of the company or by reason of any such variation, or extension being granted to the said

supplier or by reason of any such matter or thing whatsoever which under the law relating to sureties would but for this provision have effect of so relieving the guarantor.

- 5) The guarantor undertakes not to revoke this guarantee during its currency except with the previous consent of the company in writing.
- 6) Notwithstanding anything herein above contained, the liability of the guarantor under these presents is restricted to Rs _____ . The guarantee shall be in force till its expiry on _____ unless a demand is made on _____ the guarantor within SIX months from the date of expiry, all the liability of the guarantor under this guarantee shall stand fully discharged. The decision of the claimant in regard to breach of contract is final and binding on the Bank.

IN WITNESS whereof, the guarantor, acting through it authorized representative has executed this deed of Guarantee on the day, month and year first above written.

(Seal of the Bank to be affixed)

WITNESS

- 1.
- 2.

Note:

- (1) To be executed in INR 100 Non-Judicial stamp paper by any authorized Indian Bank.
- (2) To be submitted directly by banker to concerned executive in purchase dept., Please give BHEL address to banker.
- (3) Do not enclose with Bank document.
- (4) Any Modification & omissions to this are not permitted.

LIST OF CONSORTIUM BANKS**BANK GUARANTEE (BG) SHALL BE ISSUED FROM THE FOLLOWING BANKS ONLY:****Nationalized Banks**

- 1 Allahabad Bank
- 2 Andhra Bank
- 3 Bank of Baroda
- 4 Canara Bank
- 5 Corporation Bank
- 6 Central Bank
- 7 Indian Bank x
Corporation Ltd. (HSBC)
- 8 Indian Overseas Bank
- 9 Oriental Bank of Commerce
- 10 Punjab National Bank
- 11 Punjab & Sindh Bank
- 12 State Bank of India
- 13 State Bank of Hyderabad
- 14 Syndicate Bank
- 15 State Bank of Travancore
- 16 UCO Bank
- 17 Union Bank of India
- 18 United Bank of India
- 19 Vijaya Bank

Public Sector Banks

- 20 IDBI

Foreign Banks

- 21 CITI Bank N.A
- 22 Deutsche Bank AG
- 23 The Hong Kong and Shanghai Banking
- 24 Standard Chartered Bank
- 25 The Royal Bank of Scotland N.V.
- 26 J P Morgan

Private Banks

- 27 Axis Bank
- 28 The Federal Bank Limited
- 29 HDFC Bank
- 30 Kotak Mahindra Bank Ltd
- 31 ICICI Bank
- 32 IndusInd Bank
- 33 Yes Bank

Note:

- BG should be directly sent to BHEL by the issuing Bank along with covering letter.
- All BGs must be issued from BHEL consortium banks listed above.
- BHEL may accept BG from other Public Sector Banks also which are not listed above.
- BG will not be accepted from Scheduled Banks and Co-operative Banks.
- In case BG is issued from a bank located outside Indian Territory and is issued in foreign currency, the BG must be routed through and confirmed by any one of the above mentioned consortium banks.
- This list is subject to changes. Hence vendors are requested to check this list every time before issuing BGs.

DISCREPANCY IN WORDS & FIGURES – QUOTED IN PRICE BID

Following guidelines will be followed in case of discrepancy in words & figures-quoted in price bid:

- (a) If, in the price structure quoted for the required goods/services/works, there is discrepancy between the unit price and the total price (which is obtained by multiplying the unit price by the quantity), the unit price shall prevail and the total price corrected accordingly, unless in the opinion of the purchaser there is an obvious misplacement of the decimal point in the unit price, in which case the total price as quoted shall govern and the unit price corrected accordingly.
- (b) If there is an error in a total corresponding to the addition or subtraction of subtotals, the subtotals shall prevail and the total shall be corrected; and
- (c) If there is a discrepancy between words and figures, the amount in words shall prevail, unless the amount expressed in words is related to an arithmetic error, in which case the amount in figures shall prevail subject to (a) and (b) above.
- (d) If there is such discrepancy in an offer, the same shall be conveyed to the bidder with target date upto which the bidder has to send his acceptance on the above lines and if the bidder does not agree to the decision of the purchaser, the bid is liable to be ignored.

BENEFITS FOR MSE SUPPLIERS AS PER MSMED ACT 2006 AND PUBLIC PROCUREMENT POLICY 2012

MSE suppliers can avail the intended benefits only if they submit along with the offer, attested copies of either EM II certificate having deemed validity (five years from the date of issue of Acknowledgement in EM II).

Or

Valid NSIC certificate or EM II certificate along with attested copy of CA certificate (Format enclosed: ANNEXURE VIII) where deemed validity of EM II certificate of five years has expired) applicable for the relevant financial year (latest audited).

Date to be reckoned for determining the deemed validity will be the date of bid opening (Part 1 in case of two part bid).

Non-submission of such documents will lead to consideration of their bid at par with other bidders.

No benefit shall be applicable for this enquiry if any deficiency in the above required documents are not submitted before price bid opening. If the tender is to be submitted through e-procurement portal, then the above required documents are to be uploaded on the portal. Documents should be notarized or attested by a Gazette officer.

CERTIFICATE BY CHARTERED ACCOUNTANT ON LETTER HEAD

This is to certify that M/s
.....(Hereinafter referred to as `Company`) having
its registered office at is registered under MSMED Act 2006, (Entrepreneur
Memorandum No ((Part-II) dtd Category:
(Micro/Small). (Copy enclosed).

Further verified from the Books of Accounts that the investment of the company as per the
latest audited financial year **as per MSMED Act 2006 is as follows:**

1. For Manufacturing Enterprises: Investment in plant and machinery (i.e., original cost excluding land
and building and the items specified by the Ministry of Small Industries vide its notification No.S.O.1722
(E) dated October 5, 2006:

Rs.Lacs.

2. For Service Enterprises: Investment in equipment (original cost excluding land and building
and furniture, fittings and other items not directly related to the service rendered or as may be
notified under the MSMED Act, 2006:

Rs.Lacs.

The above investment of Rs. Lacs in within permissible limit of Rs..... Lacs
for.....Micro / Small (Strike off which is not applicable) Category under MSMED
Act 2006.

(or)

The company has been graduated from its original category (Micro/Small) (Strike off which is not
applicable) and the date of graduation of such enterprise from its original category is
.....(dd/mm/yy) which is within the period of 3 years from the date of graduation of such enterprise
from its original category as notified vide S.O.No.3322(E) dated 01.11.2013 published in the gazette
notification dated 04.11.2013 by Ministry of MSME.

Date:

(Signature)

Name -

Membership Number -

Seal of Chartered Accountant

PURCHASE PREFERENCE FOR MSE VENDORS:

MSE vendors quoting within a price band of L1 + 15% shall be allowed to supply up to 20% of the requirement against this tender provided

1. The MSE vendor matches the L1 price
2. L1 price is from a non MSE vendor
3. L1 price will be offered to the nearest vendor nearest to L1 in terms of price ranking (L2 – nearest to L1). In case of non-acceptance by the MSE vendor (L2) next ranking vendor will be offered who is within the L1 + 15% band (if L3 is also within 15% band).
4. 20% of the 20% (i.e. 4% of the total enquired quantity) will be earmarked for SC/ST owned MSE firms provided conditions as mentioned in (1) and (2) are fulfilled.

REQUEST FOR C FORM

NAME OF VENDOR :

VENDOR CODE ALLOTTED BY BHEL :

E mail id for c form correspondence :

BHEL PO NO	INVOICE NO	INVOICE DATE	INVOICE AMOUNT	SUPPLY FROM - STATE	SUPPLY TO - STATE	CST TIN NUMBER (SUPPLIER)	INVOICE AMOUNT EXCLUDING FREIGHT	C FORM QTR	YEAR	SUPPLY TO BHEL EDN / SITE
---------------	---------------	-----------------	-------------------	---------------------------	-------------------------	-------------------------------------	---	---------------	------	---------------------------------

Please note that one 'C' form will be issued for a quarter.

Any modification and cancellation of c form is not possible from our end since it is generated online therefore include all invoices pertaining to quarter in your request
Also check the data are correct in all respect

General Instruction:

1. C form request should be given only in this file.
2. Amount should be 100% of Invoice value but should Not include freight, Insurance etc.
3. PO No. should be numeric, starting with 4 and has 10 digits
4. For every quarter separate file to be provided
5. All Invoices pertaining to the relevant quarter to be included.
6. No corrections will be entertained once c-form is issued.

**Electronic Funds Transfer (EFT) OR
Paylink Direct Credit Form**

Please Fill up the form in **CAPITAL LETTERS** only.

TYPE OF REQUEST(Tick one): CREATE CHANGE

BHEL Vendor / Supplier Code:	<input type="text"/>
Company Name :	<input type="text"/>
Permanent Account Number(PAN):	<input type="text"/>
Address	<input type="text"/>

City: <input type="text"/>	PINCODE <input type="text"/>	STATE <input type="text"/>
----------------------------	------------------------------	----------------------------

Contact Person(s)	<input type="text"/>
Telephone No:	<input type="text"/>
Fax No:	<input type="text"/>
e-mail id:	<input type="text"/>

Bank Name:	<input type="text"/>
Bank Address:	<input type="text"/>
Bank Telephone No:	<input type="text"/>
Bank Account No:	<input type="text"/>
Account Type: Savings/Cash Credit	<input type="text"/>
9 Digit Code Number of Bank and branch appearing on MICR cheque issued by Bank	<input type="text"/>
Bank swift Code(applicable for EFT only)	<input type="text"/>
Bank IFSC code(applicable for RTGS)	<input type="text"/>
Bank IFSC code(applicable for NEFT)	<input type="text"/>

I hereby certify that the particulars given above are true, correct and complete and that I, as a representative for the above named Company, hereby authorise BHEL, EDN, Bangalore to electronically deposit payments to the designated bank account.

If the transaction is delayed or not effected at all for reasons of incomplete or incorrect information, I would not hold BHEL / transferring Bank responsible.

This authority remains in full force until BHEL, EDN, Bangalore receives written notification requesting a change or cancellation.

I have read the contents of the covering letter and agree to discharge the responsibility expected of me as a participant under ECS / EFT.

Date:

Authorised Signatory:

Designation:

Telephone NO. with STD Code

Company Seal

Bank Certificate

We certify that _____ has an Account No _____ with us and we confirm that the bank details given above are correct as per our records.

Date:

(.....)

Place:

Signature

Please return completed form along with a blank cancelled cheque or photocopy thereof to:
Bharath Heavy Electricals Ltd,
Attn:
Electronics Division, Mysore Road,
BANGALORE - 560 026

In case of any Query, please call : concerned Purchase Executive.

Terms & Conditions of Reverse Auction

Against this enquiry (**RFQ No.**) for the subject item/ system with detailed scope of supply as per enquiry specifications, BHEL may resort to "REVERSE AUCTION PROCEDURE" i.e., ON LINE BIDDING (THROUGH A SERVICE PROVIDER). The philosophy followed for reverse auction shall be English Reverse (No ties).

1. For the proposed reverse auction, technically and commercially acceptable bidders only shall be eligible to participate.
2. Those bidders who have given their acceptance for Reverse Auction (quoted against this tender enquiry (**RFQ No.**)) will have to necessarily submit "online sealed bid" in the Reverse Auction. Non-submission of "online sealed bid" by the bidder for any of the eligible items for which techno-commercially qualified, will be considered as tampering of the tender process and will invite action by BHEL as per extant guidelines in vogue.
3. BHEL will engage the services of a service provider who will provide all necessary training and assistance before commencement of on line bidding on internet.
4. In case of reverse auction, BHEL will inform the bidders the details of Service Provider to enable them to contact & get trained.
5. Business rules like event date, time, bid decrement, extension etc. also will be communicated through service provider for compliance.
6. Bidders have to fax the Compliance form (annexure IV) before start of Reverse auction. Without this, the bidder will not be eligible to participate in the event.
7. In line with the NIT terms, BHEL will provide the calculation sheet (e.g. EXCEL sheet) which will help to arrive at "Total Cost to BHEL" like Packing & forwarding charges, Taxes and Duties, Freight charges, Insurance, Service Tax for Services and loading factors (for non-compliance to BHEL standard Commercial terms & conditions) for each of the bidder to enable them to fill-in the price and keep it ready for keying in during the Auction.
8. Reverse auction will be conducted on scheduled date & time.
9. At the end of Reverse Auction event, the lowest bidder value will be known on auction portal.
10. The lowest bidder has to fax/e-mail the duly signed and filled-in prescribed format for price breakup including that of line items, if required, (Annexure VII) as provided on case-to-case basis to Service provider within two working days of Auction without fail.
11. In case BHEL decides not to go for Reverse Auction procedure for this tender enquiry, the Price bids and price impacts, if any, already submitted and available with BHEL shall be opened as per BHEL's standard practice.
12. Bidders shall be required to read the "Terms and Conditions" section of the auctions site of Service provider, using the Login IDs and passwords given to them by the service provider before reverse auction event. Bidders should acquaint themselves of the „Business Rules of Reverse Auction“, which will be communicated before the Reverse Auction.
13. If the Bidder or any of his representatives are found to be involved in Price manipulation/ cartel formation of any kind, directly or indirectly by communicating with other bidders, action *as per extant BHEL guidelines*, shall be initiated by BHEL and the results of the RA scrapped/ aborted.
14. The Bidder shall not divulge either his Bids or any other exclusive details of BHEL to any other party.
15. In case BHEL decides to go for reverse auction, the H1 bidder (whose quote is highest in online sealed bid) may not be allowed to participate in further RA process.

ANNEXURE-A
BUSINESS RULES FOR REVERSE AUCTION

This has reference to tender no **(RFQ NO.) BHEL** shall finalise the Rates for **Supply of Transformers for various** Projects through Reverse Auction mode. BHEL has made arrangement with (Service Provider), who shall be BHEL's authorized service provider for the same. Bidders should please go through the guidelines given below and submit acceptance of the same.

The technical & commercial terms are as per (a) BHEL Tender Enq. No., (b) Bidders' technical & commercial" bid and (c) subsequent correspondences between BHEL and the bidders, if any.

1. Schedule for reverse auction:

The Reverse Auction is tentatively scheduled on **DD.MM.YYYY**:

Online Sealed Bid: Start Time: 00.00 Hrs

Close Time: 00.00 Hrs

Online Reverse Auction: Start Time: 00.00 Hrs

Close Time: 00.00 Hrs

2. **Auction extension time:** If a bidder places a bid in the last **05 minutes** of closing of the Reverse Auction and if that bid gets accepted, then the auction's duration shall get extended automatically for another **05 minutes**, for the entire auction (i.e. for all the items in the auction), from the time that bid comes in. Please note that the auto-extension will take place only if a bid comes in those last **05 minutes** and if that bid gets accepted as the lowest bid. If the bid does not get accepted as the lowest bid, the auto-extension will not take place even if that bid might have come in the last **05 minutes**. In case, there is no bid in the last **05 minutes** of closing of Reverse Auction, the auction shall get closed automatically without any extension. However, bidders are advised not to wait till the last minute or last few seconds to enter their bid during the auto-extension period to avoid complications related with internet connectivity, network problems, system crash down, power failure, etc.

The above process will continue till completion of Reverse Auction.

Complaints/ Grievances, if any, regarding denial of service or any related issue should be given in writing thru e-mail/ fax to (Service Provider) with a copy to BHEL within **15 minutes** from the initial closing time of Online Reverse Auction.

3. **Bid price:** The Bidder has to quote the F.O.R. destination Price inclusive of Packing & Forwarding charges, all the routine & type tests as per tender scope, ED + cess (if applicable), CST against C-form, Freight (bidder to provide original Freight paid receipt), insurance charges, etc. including loading (if indicated by BHEL due to deviations in commercial terms) for the Items specified. Details are as shown in Excel Sheet for calculation of Landed cost.

Note: For the consideration of L1 bidder, the bid value shall be reduced by loading amount, if applicable.

4. **Bidding currency and unit of measurement:** Bidding will be conducted in {*Indian Rupees per Unit*} of the material as per the specifications.

In case of foreign currency bids, exchange rate (TT selling rate of State Bank of India) as on scheduled date of tender opening (Part-I bid in case of two part bid) shall be considered for conversion in Indian Rupees.

5. **Validity of bids:** Price shall be valid for **8 weeks** from the date of reverse auction. These shall not be subjected to any change whatsoever.

6. **Lowest bid of a bidder:** In case the bidder submits more than one bid, the lowest bid at the end of Online Reverse Auction will be considered as the bidder's final offer to execute the work.

7. **Post auction procedure:** BHEL will proceed with the Lowest Bid in the Reverse Auction for further processing.

8. **Procedure of Reverse Auctioning:**

i. **Online Sealed Bid:** This duration of online sealed bid will be **30 minutes**. All bidders have to submit their online sealed bids during this period.

ii. **Online Reverse Auction:** The "opening price" i.e. start price for RA and "bid decrement" will be decided by BHEL.

iii. **If BHEL decides the lowest online sealed bid as the starting price, then the lowest bidder in online sealed bid shall be shown as current L1 automatically by the system and no acceptance of that price is required. System shall have the provision to indicate this bid as current L1.**

iv. Bidders by offering a minimum bid decrement or the multiples thereof can displace a standing lowest bid and become "L1" and this continues as an iterative process.

v. After the completion of the online reverse auction, the Closing Price (CP) shall be available for further processing.

9. If no bid is received in the auction system/ website within the specified time duration of the online RA, then BHEL will scrap the online reverse auction process and proceed with the conventional mode of tendering (opening of the envelope sealed bids earlier submitted by the bidders).

In cases where no bidder accepts the start price, the RA may be treated as failed and sealed envelope price bids of all the techno-commercially qualified bidders shall be opened and the tender processed accordingly. **Wherever the techno-commercially acceptable bidder(s) had agreed to participate in the RA and had failed to submit the online sealed bid, the envelope sealed bids of such bidder(s) shall not be entertained.** Wherever, the evaluation is done for individual items of the package, and no bid is received for some of the item(s), RA will be considered as failed for these item(s), re-reverse auction/ retendering will be conducted for these items.

10. **Only those bidders who have submitted the "online sealed bid" within the scheduled time shall be eligible to participate further in RA process. However, the H1 bidder(s) (whose quote is highest in online sealed bid) may not be allowed to participate in further RA process.**

11. Any commercial/ technical loading shall be intimated to bidders prior to RA. The excel sheet provided in this regard shall cover all these aspects. Commercial/ technical loading if any, shall be added by the respective bidder in its price during online sealed bid & Online Reverse Auction. Modalities of loading & de-loading shall be separately intimated to the bidders.

12. Computerized reverse auction shall be conducted by BHEL through (Service Provider), on pre-specified date, while the bidders shall be quoting from their own offices/ place of their choice. Internet connectivity shall have to be ensured by bidders themselves.

During the RA if a bidder is not able to bid and requests for extension of time by fax/ e-mail/ phone then time extension of additional **15 minutes** will be given by the service provider provided such requests come before **5 minutes** of auction closing time. However, only one such request per bidder can be entertained.

Despite this extension if bidder fails to upload his prices due to extreme case of failure of Internet connectivity, (due to any reason whatsoever may be) it is the "bidders" responsibility/ decision to send fax communication immediately to (Service Provider), furnishing the price the bidder wants to bid online with a request to the service provider to upload the faxed price on line so that the service provider will upload that price on line on behalf of the Bidder. It shall be noted clearly that the concerned bidder communicating this price to service provider has to solely ensure that the fax message is received by the service provider in a readable/ legible form and also the Bidder should simultaneously check up with service provider about the clear receipt of the price faxed. It shall also be clearly understood that the bidder shall be at liberty to send such fax communications of prices to be uploaded by the service provider only within the closure of Bid time and under no circumstance it shall be allowed beyond the closure of Bid time /reverse auction. It shall also be noted that the service provider should be given a reasonable required time by the bidders, to upload such prices online and if such required time is not available at the disposal of the Service provider at the time of receipt of the fax message from the bidders, the service provider will not be uploading the prices and either BHEL or the service provider are not responsible for this unforeseen circumstances. In order to ward-off such contingent situation bidders are requested to make all the necessary arrangements/ alternatives whatever required so that they are able to circumvent such situation and still be able to participate in the reverse auction successfully. Failure of power or loss of connectivity at the premises of bidders during the Reverse auction cannot be the cause for not participating in the reverse auction. On account of this, the time for the auction cannot be extended and neither BHEL nor (Service Provider) is responsible for such eventualities.

13. Proxy bids: Proxy bidding feature is a pro-bidder feature to safe guard the bidder's interest of any internet failure or to avoid last minute rush. The proxy feature allows bidders to place an automated bid in the system directly in an auction and bid without having to enter a new amount each time a competing bidder submits a new offer. The bid amount that a bidder enters is the minimum that the bidder is willing to offer. Here the software bids on behalf of the bidder. This obviates the need for the bidder participating in the bidding process until the proxy bid amount is decrementally reached by other bidders. When proxy bid amount is reached, the bidder (who has submitted the proxy bid) has an option to start participating in the bidding process.

The proxy amount is the minimum amount that the bidder is willing to offer. During the course of bidding, the bidder cannot delete or change the amount of a proxy bid.

Bids are submitted in decrements (decreasing bid amounts). The application automates proxy bidding by processing proxy bids automatically, according to the decrement that the auction originator originally established when creating the auction, submitting offers to the next bid decrement each time a competing bidder bids, regardless of the fact whether the competing bids are submitted as proxy or standard bids. However, it may please be noted that if a manual bid and proxy bid are submitted at the same instant manual bid will be recognized as the L1 at that instant.

In case of more than one proxy bid, the system shall bid till it crosses the threshold value of 'each lowest proxy bid' and thereafter allow the competition to decide the final L1 price.

Proxy bids are fed into the system directly by the respective bidders. As such this information is privy only to the respective bidder(s).

14. Bidders are advised to get fully trained and clear all their doubts such as refreshing of Screen, quantity being auctioned, tender value being auctioned etc.

15. (Service Provider), shall arrange to demonstrate/ train the bidder or bidder's nominated person(s), without any cost to bidders. (Service Provider) shall also explain the bidders, all the rules related to the Reverse Auction/ Business Rules Document to be adopted along with bid manual. Bidders are required to give their compliance on it before start of bid process.

16. Successful bidder shall be required to submit the final prices, quoted during the Online Reverse Auction in **Annexure -C** after the completion of auction to (Service Provider) **besides** BHEL, duly signed and stamped as token of acceptance without any new condition other than those already agreed to before start of auction.

17. Any variation between the final bid value and that in the confirmatory signed price breakup document will be considered as tampering the tender process and will invite action by BHEL as per extant guidelines in vogue.

18. Bidder's bid will be taken as an offer to execute the work/ supplies the item as per enquiry no **(RFQ NO.)**. Bids once made by the bidder, cannot be cancelled/ withdrawn and bidder shall be bound to execute the work as mentioned above at bidder's final bid price. Should bidder back out and not execute the contract as per the rates quoted, BHEL shall take action as per extant guidelines in vogue.

19. Bidders shall be assigned a **Unique User Name & Password** by BHEL or (Service Provider). **Bidders** are advised to change the Password and edit the information in the Registration Page after the receipt of initial Password from BHEL/ (Service Provider) to ensure confidentiality. All bids made from the Login ID given to the bidders will be deemed to have been made by the bidders/ bidder's company.

20. Bidders shall be able to view the following on their screen along with the necessary fields during Online Reverse Auction:

a. Leading (Running Lowest) Bid in the Auction (only total price of package)

b. Bid Placed by the bidder

c. Start Price

d. Decrement value

21. After receipt of the system report from the Service Provider after completion of the Online Reverse Auction, BHEL will decide upon the winner. BHEL's decision on award of contract shall be final and binding on all the Bidders.

22. BHEL reserves the right to cancel the Reverse Auction process/ tender at any time, before ordering, without assigning any reason.

23. BHEL shall not have any liability to bidders for any interruption or delay in access to the site irrespective of the cause. In such cases, the decision of BHEL shall be binding on the bidders.

24. Other terms and conditions shall be as per bidder's techno-commercial offers and other correspondences, if any, till date.

25. Bidders are required to submit their acceptance to the terms/ conditions/ modalities before participating in the Reverse Auction in the process compliance Form as per Annexure-B.

26. BHEL can decide to extend, reschedule or cancel any Auction with prior intimation to all bidders.

27. If there is any clash between this business document and the FAQ available, if any, in the web site of (Service Provider) the terms& conditions given in this business document will supersede the information contained in the FAQs. Any changes made by BHEL/service provider (due to unforeseen contingencies) after the first posting shall be deemed to have been accepted if the bidder continues to access the portal after that time.

Annexure – B
Process Compliance Form

(The bidders are required to print this on their company's letterhead and sign, stamp before faxing)

To

(Service Provider)

Sub: Agreement to the Process related Terms and Conditions

Dear Sir,

This has reference to the Terms & Conditions for the Reverse Auction mentioned in the RFQ document for **(Package Name)** against BHEL enquiry/ RFQ no. **_____**

This letter is to confirm that:

1. The undersigned is authorized official/ representative of the company to participate in RA and to sign the related documents.
2. We have studied the Reverse Auction Terms & Conditions and the Business rules governing the Reverse Auction as mentioned in your letter and confirm our agreement to them.
3. We also confirm that we have taken the training on the auction tool and have understood the functionality of the same thoroughly.
4. We also confirm that, in case we become L1 bidder, we will email/ fax the price confirmation & break up of our quoted price (including that of line items) as per Annexure - C within two working days (of BHEL) after completion of RA event, besides sending the same by registered post/courier both to M/s. BHEL and (Service Provider).

We, hereby confirm that we will honour the Bids placed by us during the auction process.

With regards

Signature with company seal

Name –

Company / Organization

Designation within Company / Organization

Address of Company / Organization

- Sign this document and Fax it to (Service Provider) to the contact person prior to start of the Event.
- Attach a signed copy of the RFQ document along with the Agreement Form/ Process Compliance form and send to (Service Provider)

Annexure - C
RA price confirmation and breakup

To

M/s. Service Provider

CC: M/s. BHEL EDN
Mysore Road,
Bangalore-560026

Sub: Final price quoted during Reverse Auction and price breakup

Dear Sir,

We confirm that we have quoted Rs. _____ **for items covered under tender enquiry No.**

Total price of the items covered under above cited enquiries is inclusive of {Packing & forwarding, applicable taxes & duties, freight and insurance charges upto District,State and other as per NIT} as our final landed prices as quoted during the Reverse Auction conducted today DD.MM.YYYY which will be valid for a period of ____ days.

The price break-up including that of line items is as given below.

Total:

Thanking you and looking forward to the valuable order from BHEL.

Yours sincerely,

For _____

Name:

Company:

Date:

Seal:



ಭಾರತ್ ಹೆವಿ ಎಲೆಕ್ಟ್ರಿಕಲ್ಸ್ ಲಿಮಿಟೆಡ್
भारत हेवी इलेक्ट्रिकल्स लिमिटेड

Bharat Heavy Electricals Ltd.,
(A Government of India undertaking)
Electronics Division

PB 2606 , Mysore Road Bangalore , 560026 INDIA

SCPV: BOS: 002- Rev 00

GENERAL COMMERCIAL CONDITIONS FOR CONTRACT

These 'General Commercial Conditions for Contract for Purchase' hereinafter referred to as GCC apply to all enquiries, tenders, requests for quotations, orders, contracts and agreements concerning the supply of goods and the rendering of related services (hereinafter referred to as "deliveries") to Bharat Heavy Electricals Limited and any of its units, regions or divisions (hereinafter referred to as "BHEL" or the Purchaser) or its projects / customers.

Any deviations from or additions to these GCC require BHEL's express written consent. The general terms of business or sale of the vendor shall not apply to BHEL. Acceptance, receipt of shipments or services or effecting payment shall not mean that the general terms of business or sale of the vendor have been accepted.

Orders, agreements and amendments thereto shall be binding if made or confirmed by BHEL in writing. Only the Purchasing department of BHEL is authorized to issue the Purchase Order or any amendment thereof.

Definitions: Throughout these conditions and in the specifications, the following terms shall have the meanings assigned to them, unless the subject matter or the context requires otherwise.

- a) 'The Purchaser' means Bharat Heavy Electricals Limited, Electronics division, Mysore road, Bangalore 560 026, a Unit of Bharat Heavy Electricals Limited (A Govt. of India Undertaking) incorporated under the Companies Act having its registered office at BHEL House, Siri Fort, New Delhi-110049, India and shall be deemed to include its successors and assigns. It may also be referred to as BHEL.
- b) 'The vendor' means the person, firm, company or organization on whom the Purchase Order is placed and shall be deemed to include the vendor's successors, representative heirs, executors and administrator as the case may be. It may also be referred to as Seller, Contractor or Supplier.
- c) 'Contract' shall mean and include the Purchase Order incorporating various agreements, viz. tender/ RFQ, offer, letter of intent / acceptance / award, the General Conditions of Contract and Special Conditions of Contract for Purchase, Specifications, Inspection / Quality Plan, Schedule of Prices and Quantities, Drawings, if any enclosed or to be provided by BHEL or his authorized nominee and the samples or patterns if any to be provided under the provisions of the contract.
- d) 'Parties to the Contract' shall mean the 'The Vendor' and the Purchaser as named in the main body of the Purchase Order.
- e) "Bidder" shall mean duly established reputed organisation , manufacturer etc. having requisite financial and technical capability and experience of participating in the bid invited by the purchaser for the tender.
- f) Bid- The term "bid" or "bidding" can also relate to the documented Offer submitted in response to a request for quotation (RFQ) /Tender.

Interpretation:

In the contract, except where the context requires otherwise:

- a) words indicating one gender include all genders;
- b) words indicating the singular also include the plural and words indicating the plural also include the singular;
- c) provisions including the word "agree", "agreed" or "agreement" require the agreement to be recorded in writing, and

- d) "Written" or "in writing" means hand-written, type-written, printed or electronically made, and resulting in a permanent record.

Applicable Conditions:

1. **Price Basis:** All prices shall be firm until the purchase order is executed / completed in all respects. No price variations / escalation shall be permitted unless otherwise such variations / escalations are provided for and agreed by BHEL in writing in the purchase order.
2. **Validity:** The offer will be valid for a period of **90 days** from the date of technical bid opening date. Validity beyond **90 days, if required**, will be specified in the SCC (special conditions of contract).
3. **Ordering and confirmation of Order:** Vendor shall send the order acceptance on their company letter head within two weeks from the date of Purchase Order or such other period as specified / agreed by BHEL. BHEL reserves the right to revoke the order placed if the order confirmation differs from the original order placed. The acceptance of goods/services/supplies by BHEL as well as payments made in this regard shall not imply acceptance of any deviations.
The purchase order will be deemed to have been accepted if no communication to the contrary is received within two weeks (or the time limit as specified / agreed by BHEL) from the date of the purchase order.
4. **Documentation:** After receipt of Purchase Order, vendor should submit required documents like drawings, bill of materials, datasheets, catalogues, quality plan, test procedure, type test report , O & M Manuals and/or any other relevant documents as per Specification/Purchase Order, as and when required by BHEL/Customer.
At any stage within the contract period, the vendor shall notify of any error, fault or other defect found in BHEL's documents /specifications or any other items for reference. If and to the extent that (taking account of cost and time) any vendor exercising due care would have discovered the error, fault or other defect when examining the documents/specifications before submitting the tender, the time for completion shall not be extended. However if errors, omissions, ambiguities, inconsistencies, inadequacies or other defects are found in the vendor's documents, they shall be corrected at his cost, notwithstanding any consent or approval.

5. TERMS OF DELIVERY:

FOR IMPORTED PURCHASE:

Price offered shall be for goods packed and delivered FOB Seaport,/FCA International Airport including packing, forwarding, Handling, Ancillary charges like processing of Sight Draft, negotiation charges of bank, Export declaration, Certificate of origin etc.

Packing shall be Air/Sea worthy, best suitable for trans-shipment and to take care of transit damages. If containerized, no. of containers & size of container shall be mentioned. Packing weight (gross & net) Packing dimensions shall be given prior to shipment to ascertain whether the consignment can be carried on standard cargo in contract or as ODC.

Wooden packing material for all the foreign consignments should be treated as per ISPM-15 & Fumigation / Phytosanitary certificate to be submitted to the freight forwarders/ BHEL along with the invoice, B/L, packing list etc.

Vendors shall indicate the name of International Airport/Seaport. Approved Airports are as per Annexure-C. The consignment shall be handed over to BHEL approved freight forwarder as mentioned in PO.

FOR INDIGENOUS PURCHASE:

Equipment shall be delivered on "FOR SITE" basis, inclusive of freight, packing, insurance & forwarding charges.

Packing shall be Road / Rail / Air / Sea worthy, best suitable for transshipment and to take care of transit damages. Smaller consignments can be dispatched through Courier services/ RPP with the prior approval of the purchasing Executive.

Deviation for the delivery term is liable for rejection.

6. Penalty:

For delay in delivery: In the event of delay in agreed contractual delivery as per Purchase Order, penalty @ 0.5 % (half percent) per week or part thereof but limited to a max of 10% (ten percent) value of undelivered portion (basic material cost) will be applicable. Delivery will commence from the date of document approval by customer / BHEL or date of issue of manufacturing clearance, whichever is later. The date for which Inspection call is issued by vendor along with test certificates / test reports / Certificate of Conformance / calibration reports, as proof of completion of manufacturing will be treated as date of deemed delivery for penalty calculation. In the absence of furnishing such document indicated above as proof of completion of manufacturing along with inspection call, actual date of inspection will be considered as date of deemed delivery and BHEL will not be responsible for delay in actual date of inspection.

Penalty for delayed documentation/delayed delivery, if applicable, shall be deducted at the time of first payment. If penalty is applicable for duration of less than a week, penalty @ 0.5% (half percent) of the basic material value will be deducted.

7. **Contract variations (Increase or decrease in the scope of supply):** BHEL may vary the contracted scope as per requirements at site. If vendor is of the opinion that the variation has an effect on the agreed price or delivery period, BHEL shall be informed of this immediately in writing along with technical details. Where unit rates are available in the Contract, the same shall be applied to such additional work. Vendor shall not perform additional work before BHEL has issued written instructions / amendment to the Purchase Order to that effect. The work which the vendor should have or could have anticipated in terms of delivering the service(s) and functionality (i.e.) as described in this agreement, or which is considered to be the result of an attributable error on the vendor's part, shall not be considered additional work.
8. **Reverse Auction:** BHEL reserves the right to follow REVERSE AUCTION PROCEDURE (ONLINE BIDDING ON NETWORK) before finalising the Purchase order on technically competent bidders, as per the guidelines given in Annexure XII. In case BHEL does not resort to Reverse Auction, the price bids and price impacts (if any) already submitted and available with BHEL shall be opened as per BHEL's standard practice.
9. **Pre Shipment Inspection:** Prior written notice of at least 10 days shall be given along with internal test certificates / COC and applicable test certificates. Materials will be inspected by BHEL-EDN-QS/CQS or BHEL nominated Third Party Inspection Agency (TPIA) or BHEL authorized Inspection Agency or Customer / Consultant or jointly by BHEL & Customer / consultant. All tests have to be conducted as applicable in line with approved Quality plan or QA Checklist or Purchase specification and original reports shall be furnished to BHEL-EDN, Bangalore for verification / acceptance for issue of dispatch clearance.
All costs related to inspections & re-inspections shall be borne by vendor. Whether the Contract provides for tests on the premises of the vendor or any of his Sub-contractor/s, vendor shall be responsible to provide such assistance, labour, materials, electricity, fuels, stores, apparatus, instruments as may be required and as may be reasonably demanded to carry out such tests efficiently. Cost of any type test or such other special tests shall be borne by BHEL only if specifically agreed to in the purchase order.
10. **Transit Insurance:** Transit Insurance is in Vendor's scope for all Inclusive value or as specified in RFQ.
For imported items with FOB / ex-Works terms contracts, BHEL will provide Insurance.

11. **High Sea Sales (HSS):** Customs clearance of the consignment landed on Indian Sea / Air ports will be done by BHEL based on the original HSS documents provided by vendors. Any delay in submission of complete / correct HSS documents to BHEL may incur demurrage charges. All demurrage charges on account of incomplete / incorrect HSS documents submission by vendor will be to vendor's account and all such charges will be recovered from any of the available vendor bills with BHEL.
12. **Packaging and dispatch:** The Seller shall package the goods safely and carefully and pack them suitably in all respects considering the peculiarity of the material for normal safe transport by Sea / Air / Rail / Road to its destination suitably protected against loss, damage, corrosion in transit and the effect of tropical salt laden atmosphere. The packages shall be provided with fixtures / hooks and sling marks as may be required for easy and safe handling. If any consignment needs special handling instruction, the same shall be clearly marked with standard symbols / instructions. Hazardous material should be notified as such and their packing, transportation and other protection must conform to relevant regulations. The packing, shipping, storage and processing of the goods must comply with the prevailing legislation and regulations concerning safety, the environment and working conditions. Any Imported/Physical Exports items packed with raw / solid wood packing material should be treated as per ISPM - 15 (fumigation) and accompanied by Phytosanitary / Fumigation certificate. If safety information sheets (MSDS - Material Safety Data Sheet) exist for an item or the packaging, vendor must provide this information without fail along with the consignment. Each package must be marked with Consignee name, Purchase order number, Package number, Gross weight and net weight, dimensions (L x B x H) and Seller's name. Packing list of goods inside each package with PO item number and quantity must also be fixed securely outside the box to indicate the contents of each box. Total number of packages in the consignment must also be indicated. Separate packing & identification of items should be as follows.
1. Main Scope - All items must be tagged with part no. & item description.
 2. Commissioning spares - All items must be tagged with part no. & item description.
 3. Mandatory spares - All items must be tagged with part no. & item description.
13. **Assignment of Rights & Obligations; Subcontracting:** Vendor is not permitted to subcontract the delivery or any part thereof to third party or to assign the rights and obligations resulting from this agreement in whole or in part to third parties without prior written permission from BHEL. Any permission or approval given by the BHEL shall, however, not absolve the vendor of the responsibility of his obligations under the Contract.
14. **Progress report:** Vendor shall render such report as to the progress of work and in such form as may be called for by the concerned purchase officer from time to time. The submission and acceptance of such reports shall not prejudice the rights of BHEL in any manner.
15. **Non-disclosure and Information Obligations: Vendor** shall provide with all necessary information pertaining to the goods as it could be of importance to BHEL. Vendor shall not reveal confidential information that may be divulged by BHEL to Vendor's employees not involved with the tender/ contract & its execution and delivery or to third parties, unless BHEL has agreed to this in writing beforehand. Vendor shall not be entitled to use the BHEL name in advertisements and other commercial publications without prior written permission from BHEL.
16. **Cancellation / Termination of contract:** BHEL shall have the right to completely or partially terminate the agreement by means of written notice to that effect. Termination of the Contract, for whatever reason, shall be without prejudice to the rights of the parties accrued under the Contract up to the time of termination. BHEL shall have the right to cancel/foreclose the Order/ Contract, wholly or in part, in case it is constrained to do so, on account of any decline, diminution, curtailment or stoppage of the business.
17. **Risk Purchase Clause:** In case of failure of supplier, BHEL at its discretion may make purchase of the materials / services NOT supplied / rendered in time at the RISK & COST of the supplier. Under such situation, the supplier who fails to supply the goods in time shall be wholly liable to make good to BHEL any loss due to risk purchase.

In case of items demanding services at site like erection and commissioning, vendor should send his servicemen /representatives within 7 days from the service call. In case a vendor fails to attend to the service call, BHEL at its discretion may also make arrangements to attend such service by other parties at the **RISK & COST** of the supplier. Under such situation the supplier who fails to attend the service shall be wholly liable to make good to BHEL any loss due to risk purchase / service including additional handling charges due to the change.

18. **Shortages:** In the event of shortage on receipt of goods and/or on opening of packages at site, all such shortages shall be made good within a reasonable time that BHEL may allow from such intimation and free of cost.
Transit Damages: In the event of receipt of goods in damaged condition or having found them so upon opening of packages at site, Supplier shall make good of all such damages within a reasonable time from such intimation by BHEL.
19. **Remedial work:** Notwithstanding any previous test or certification, BHEL may instruct the vendor to remove and replace materials/goods or remove and re-execute works/services which are not in accordance with the purchase order. Similarly BHEL may ask the vendor to supply materials or to execute any services which are urgently required for any safety reasons, whether arising out of or because of an accident, unforeseeable event or otherwise. In such an event, Vendor shall provide such services within a reasonable time as specified by BHEL.
20. **Indemnity Clause:** Vendor shall comply with all applicable safety regulations and take care for the safety of all persons involved. Vendor is fully responsible for the safety of its personnel or that of his subcontractor's men / property, during execution of the Purchase Order and related services. All statutory payments including PF, ESI or other related charges have to be borne by the vendor. Vendor is fully responsible for ensuring that all legal compliances are followed in course of such employment.
21. **Product Information, Drawings and Documents:** Drawings, technical documents or other technical information received by Vendor from BHEL or vice versa shall not, without the consent of the other party, be used for any other purpose than that for which they were provided. They may not, without the consent of the Disclosing party, otherwise be used or copied, reproduced, transmitted or communicated to third parties. All information and data contained in general product documentation, whether in electronic or any other form, are binding only to the extent that they are by reference expressly included in the contract.
Vendor, as per agreed date/s but not later than the date of delivery, provide free of charge information and drawings which are necessary to permit and enable BHEL to erect, commission, operate and maintain the product. Such information and drawings shall be supplied in as many numbers of copies as may be agreed upon.
All intellectual properties, including designs, drawings and product information etc. exchanged during the formation and execution of the Contract shall continue to be the property of the disclosing party.
22. **Intellectual Property Rights, Licenses:** If any Patent, design, Trade mark or any other intellectual property rights apply to the delivery (goods / related service) or accompanying documentation shall be the exclusive property of the Vendor and BHEL shall be entitled to the legal use thereof free of charge by means of a non-exclusive, worldwide, perpetual license. All intellectual property rights that arise during the execution of the Purchase Order/ contract for delivery by vendor and/or by its employees or third parties involved by the vendor for performance of the agreement shall belong to BHEL. Vendor shall perform everything necessary to obtain or establish the above mentioned rights. The Vendor guarantees that the delivery does not infringe on any of the intellectual property rights of third parties. The Vendor shall do everything necessary to obtain or establish the alternate acceptable arrangement pending resolution of any (alleged) claims by third parties. The Vendor shall indemnify BHEL against any (alleged) claims by third parties in this regard and shall reimburse BHEL for any damages suffered as a result thereof.
23. **Force Majeure:** Notwithstanding anything contained in the purchase order or any other document relevant thereto, neither party shall be liable for any failure or delay in performance to the extent said failures or delays are caused by the "Act of God" and occurring without its fault or negligence,

provided that, force majeure will apply only if the failure to perform could not be avoided by the exercise of due care and vendor doing everything reasonably possible to resume its performance.

A party affected by an event of force majeure which may include fire, tempest, floods, earthquake, riot, war, damage by aircraft etc., shall give the other party written notice, with full details as soon as possible and in any event not later than seven (7) calendar days of the occurrence of the cause relied upon. If force majeure applies, dates by which performance obligations are scheduled to be met will be extended for a period of time equal to the time lost due to any delay so caused.

Notwithstanding above provisions, in an event of Force Majeure, BHEL reserves for itself the right to cancel the order/ contract, wholly or partly, in order to meet the overall project schedule and make alternative arrangements for completion of deliveries and other schedules.

24. **Guarantee / Warranty:** Wherever required, and so provided in the specifications / Purchaser Order, the Seller shall guarantee that the stores supplied shall comply with the specifications laid down, for materials, workmanship and performance. The guarantee / warranty period as described above shall apply afresh to replaced, repaired or re-executed parts of a delivery. Unless otherwise specifically provided in the Purchase Order, Vendor's liability shall be co terminus with the expiration of the applicable guarantee / warranty period.
25. **Limitation of Liability:** Vendor's liability towards this contract is limited to a maximum of 100% of the contract value and consequential damages are excluded. However the limits of liability will have no effect in cases of criminal negligence or wilful misconduct.
The total liability of Vendor for all claims arising out of or relating to the performance or breach of the Contract or use of any Products or Services or any order shall not exceed the total Contract price.
26. **Liability during guarantee / warranty:** Vendor shall arrange replacement / repair of all the defective materials / services under its obligation under the guarantee / warranty period. The rejected goods shall be taken away by vendor and replaced / repaired. In the event of the vendor's failure to comply, BHEL may take appropriate action including disposal of rejections and replenishment by any other sources at the cost and risk of the vendor.
In case, defects attributable to vendor are detected during first time commissioning or use, vendor shall be responsible for replacement / repair of the goods as required by BHEL at vendor's cost. In all such cases expiry of guarantee / warranty will not be applicable.
27. **Liability after guarantee / warranty period:** At the end of the guarantee / warranty, the Vendor's liability ceases except for latent defects (latent defects are defects / performance issues notices after the guarantee / warranty has expired). The Contractor's liability for latent defects warranty for the plant and equipment including spares shall be limited to a period of six months from the end of the guarantee / as specified in RFQ.
28. **Compliance with Laws:** Vendor shall, in performing the contract, comply with all applicable laws. The vendor shall make all remittances, give all notices, pay all taxes, duties and fees, and obtain all permits, licences and approvals, as required by the laws in relation to the execution and completion of the contract and for remedying of any defects; and the Contractor shall indemnify and hold BHEL harmless against and from the consequences of any failure to do so.
29. **Settlement of Disputes:** Except as otherwise specifically provided in the Purchase Order, decision of BHEL shall be binding on the vendor with respect to all questions relating to the interpretation or meaning of the terms and conditions and instructions herein before mentioned and as to the completion of supplies/work/services, other questions, claim, right, matter or things whatsoever in any way arising out of or relating to the contract, instructions, orders or these conditions or otherwise concerning the supply or the execution or failure to execute the order, whether arising during the schedule of supply/work or after the completion or abandonment thereof. Any disputes or differences among the parties shall to the extent possible be settled amicably between the parties thereto, failing which the disputed issues shall be settled through arbitration. Vendor shall continue to perform the contract, pending settlement of dispute(s).
30. **Arbitration Clause:** In case amicable settlement is not reached in the event of any dispute or difference arising out of the execution of the Contract or the respective rights and liabilities of the

parties or in relation to interpretation of any provision in any manner touching upon the Contract, such dispute or difference shall (except as to any matters, the decision of which is specifically provided for therein) be referred by either party to the sole arbitration of an Arbitrator appointed by the Executive Director/ General Manager of the purchasing unit/ region/ division of BHEL. Vendor shall have no objection even if the Arbitrator so appointed is an employee of BHEL or has ever dealt/ had to deal with any matter relating to this Contract.

Subject as aforesaid the provisions of the Arbitration and Conciliation Act, 1996 of India or any statutory modification or re-enactment thereof and the rules made there under and for the time being in force shall apply to the arbitration proceedings under this clause. It is a term of contract that the party initiating arbitration shall specify the dispute or disputes to be referred to arbitration under this clause together with the amount or amounts claimed in respect of each such dispute. The venue for the arbitration shall be Bangalore, India. The award of the arbitrator shall be a speaking award and shall be final, conclusive and binding on all parties to this contract.

The cost of arbitration shall be borne equally by the parties. Notwithstanding the existence of any dispute or difference or any reference for the arbitration, the vendor shall proceed with and continue without hindrance the performance of the work under the contract with due diligence and expedition in a professional manner.

31. **Applicable Laws and Jurisdiction of Courts:** Prevailing Indian laws both substantive and procedural, including modifications thereto, shall govern the Contract. Subject to the conditions as aforesaid, the competent courts in BANGALORE alone shall have jurisdiction to consider over any matters touching upon this contract.

32. **General Terms:** That any non-exercise, forbearance or omission of any of the powers conferred on BHEL and /or any of its authorities will not in any manner constitute waiver of the conditions hereto contained in these presents.

That the headings used in this agreement are for convenience of reference only.

That all notices etc., to be given under the Purchase order shall be in writing, type script or printed and if sent by registered post or by courier service to the address given in this document shall be deemed to have been served on the date when in the ordinary course, they would have been delivered to the addressee.



ಭಾರತ್ ಹೆವಿ ಎಲೆಕ್ಟ್ರಿಕಲ್ಸ್ ಲಿಮಿಟೆಡ್
 भारत हेवी इलेक्ट्रिकल्स लिमिटेड

Bharat Heavy Electricals Ltd.,
(A Government of India undertaking)
Electronics Division

PB 2606 , Mysore Road Bangalore , 560026 INDIA

SCPV: BOS: 001- Rev 00

INSTRUCTIONS TO BIDDERS (Common for all RFQs)

Bidder is requested to read the instructions carefully and submit their quotation covering all the points:

A. GENERAL INSTRUCTIONS:

1. Any Purchase Order resulting from this enquiry shall be governed by the Instructions to Bidders (document reference: SCPV: BOS: 001 – Rev 00), General Conditions of Contract (document reference: SCPV: BOS: 002 - Rev 00) and Special Conditions of Contract, if any, of the enquiry.
2. Any deviations from or additions to the “General Conditions of Contract” or “Special Conditions of Contract” require BHEL’s express written consent. The general terms of business or sale of the bidder shall not apply to this tender.
3. Bidders (also includes the term suppliers / contractors wherever used in this document) are instructed to quote their most competitive price and best delivery, etc. in the offer. Prices should be indicated in both figures & words. **(Please also refer clause 11 under section B)**
4. Regret letter (either through post or by mail) indicating reasons for not quoting must be submitted without fail, in case of non-participation in this tender. If a bidder fails to respond against 3 consecutive tenders for the same item, he will be liable for removal as a registered vendor of BHEL.
5. Procurement directly from the manufacturers shall be preferred. However, if the OEM / Principal insist on engaging the services of an agent, such agent shall not be allowed to represent more than one manufacturer / supplier in the same tender. Moreover, either the agent could bid on behalf of the manufacturer / supplier or the manufacturer / supplier could bid directly but not both. In case bids are received from the manufacturer / supplier and his agent, bid received from the agent shall be ignored.
6. Consultant / firm (and any of its affiliates) shall not be eligible to participate in the tender/s for the related goods for the same project if they were engaged for consultancy services for the same project.
7. If an Indian representative / associate / liaison office quotes on behalf of a foreign based bidder, such representative shall furnish compulsorily the following documents:
 - a. Authorization letter to quote and negotiate on behalf of such foreign-based bidder.
 - b. Undertaking from such foreign based bidder that such contract will be honored and executed according to agreed scope of supply and commercial terms and conditions.
 - c. Undertaking shall be furnished by the Indian representative stating that the co-ordination and smooth execution of the contract and settlement of shortages / damages / replacement / repair of imported scope till system is commissioned and handed over to customer will be the sole responsibility of the Indian representative / associates / agent / liaison office.
8. In case of imported scope of supply, customs clearance & customs duty payment will be to BHEL account after the consignment is received at Indian Airport / Seaport. Bidders must provide all original documents required for completing the customs clearance along with the shipment. Warehousing charges due to incomplete or missing documentation will be recovered from the supplier’s bill. All offers for imported scope of supply must be made from any of the gateway ports (within the country) indicated. **(Refer Annexure I)**
9. The offers of the bidders who are on the banned list and also the offers of the bidders, who engage the services of the banned firms, shall be rejected. The list of the banned firms is available on BHEL website: **www.bhel.com**

10. Business dealings with bidders will be suspended if they are found to have indulged in any malpractices / misconduct which are contrary to business ethics like bribery, corruption, fraud, pilferage, cartel formation, submission of fake/false/forged documents, poor quality, certificates, information to BHEL or if they tamper with tendering procedure affecting the ordering process or fail to execute a contract, or rejection of 3 consecutive supplies or if their firms / works are under strike / lockout for a long period.

B. GUIDELINES FOR PREPARATION OF OFFER:

1. Quotation shall be submitted in Single Part Bid, Two Part Bid or Three Part Bid, as called for in the tender:
 - **SINGLE PART BID:** Technical and Commercial Bid with prices along with price summary & filled in BHEL Standard Commercial terms and conditions in a single sealed envelope.
 - **TWO PART BID:** Unpriced offer i.e. "Techno-commercial Bid" with filled in BHEL Standard Commercial terms and conditions in a sealed envelope **along with the copy of the "Price Bid" without the prices** should be enclosed in one cover and the cover must be super scribed "**Techno-commercial offer**) and Priced offer i.e. "Price Bid" containing price summary in a separate sealed envelope and must be super scribed "**Price Bid**". Both these envelopes shall be enclosed in a single sealed envelope super scribed with enquiry number due date of tender and any other details as called for in the tender document.
 - **THREE PART BID:** Pre-qualification Bid (Part-I), Techno Commercial Bid with filled in BHEL Standard Commercial terms and conditions (Part-II), and Price Bid (Part-III). All three envelopes shall be enclosed in a single sealed envelope super scribed with enquiry number due date of tender and any other details as called for in the tender document.

If any of the offers (Part I, Part II or Part III) are not submitted before the due date and time of submission at the venue/place specified or if any part of the offer is incomplete the entire offer of the bidder is liable for rejection.

2. Supplier shall ensure to super scribe each envelope with RFQ number, RFQ Date, RFQ Due date and time, Item Description and Project clearly & boldly. Also mention on the envelope whether it is "Techno Commercial Bid" or "Price Bid" or "Pre-Qualification Bid". Please ensure complete address, department name and purchase executive name is mentioned on the envelope (before dropping in the tender box or handing over) so that the tender is available in time for bid opening.
3. BHEL standard Commercial Terms and Conditions shall be duly filled, signed & stamped and must accompany Technical-Commercial offer without fail and should be submitted in original only. Xerox copy will not be accepted.
4. Any of the terms and conditions not acceptable to supplier, shall be explicitly mentioned in the Techno-Commercial Bid. If no deviations are brought out in the offer it will be treated as if all terms and conditions of this enquiry are accepted by the supplier without any deviation.
5. Deviation to this specification / item description, if any, shall be brought out clearly indicating "DEVIATION TO BHEL SPECIFICATION" without fail, as a part of Techno-Commercial Bid. If no deviations are brought out in the offer it will be treated as if the entire specification of this enquiry is accepted without deviation.
6. Suppliers shall submit one set of original catalogue, datasheets, bill of materials, dimensional drawings, mounting details and / or any other relevant documents called in purchase specification as part of Technical Bid.
7. "Price Bid" shall be complete in all respects containing price break-up of all components along with all applicable taxes and duties, packing & forwarding charges (if applicable), freight charges (if applicable) etc. Once submitted no modification / addition / deletion will be allowed in the "Price Bid." Bidders are advised to thoroughly check the unit price, total price to avoid any discrepancy.
8. In addition, bidder shall also quote for erection & commissioning charges (E&C charges), documentation charges, service charges, testing Charges (type & routine), training charges, service tax, etc. wherever applicable. The price summary must indicate all the elements clearly.
9. Vendors should indicate "lump sum" charges (including To & Fro Fare, Boarding, Lodging, Local Conveyance etc.) for Supervision of Erection, Commissioning and handing over to customer. The quotation shall clearly indicate scope of work, likely duration of commissioning, pre-commissioning checklist and service tax (if any).
10. Wherever bidders require PAC (Project Authority Certificate) for import of raw materials, components required for Mega Power Projects, Export Projects, MNRE Concession or other similar projects wherein supplies are

eligible for customs duty benefits, lists and quantities of such items and their values (CIF) has to be mentioned in the offer. Prices must be quoted taking into account of such benefits.

11. All quotations shall be free from corrections /overwriting. Corrections if any should be authenticated with signature and seal. Any typographical error, totaling mistakes, currency mistake, multiplication mistake, summing mistakes etc. observed in the price bids will be evaluated as per **Annexure VI** "Guidelines for dealing with Discrepancy in Words & Figures – quoted in price bid". BHEL decision will be final.

C. GUIDELINES FOR OFFER SUBMISSION:

1. Offers / Quotations must be dropped in tender box before 13.00 Hrs. on or before due date mentioned in RFQ. The offers are to be dropped in the proper slot of the Tender Box kept in our reception area with caption "CE, SC&PV, DEFENCE." Tenders are opened on 3 days in a week (Monday/Wednesday/Friday). Tender must be deposited in the slot corresponding to the day (Monday - Box no.4/Wednesday - Box no. 6 /Friday - Box no.8) while depositing the offer. **(This clause will not be applicable for e-tenders)**
2. E-Mail / Internet / EDI offers received in time shall be considered only when such offers are complete in all respects. In case of offers received through E-mail, please send the offer to the email ID specified in the SCC of the tender. (Refer to SCC document of tender) within time of submission of tender.
3. In cases where tender documents are bulky, or due to some reasons tender documents are required to be submitted by hand or through posts/couriers, the offers are to be handed over either of the two officers whose names are mentioned in the RFQ. (Refer to SCC document of tender)
4. Tenders will be opened on due date, time and venue as indicated in the RFQ in the presence of bidders at the venue indicated in the RFQ. In case of e-procurement, bidders can see tender results till seven days after due date and time.
5. Vendor will be solely responsible:
 - a. For submission of offers before due date and time. Offers submitted after due date and time will be treated as "Late offers" and will be rejected.
 - b. For submission of offers in the correct compartment of the tender box based on the day of due date (Monday/Wednesday/Friday). Please check before dropping your offer in the correct tender box.
 - c. For depositing offers in proper sealed condition in the tender box. If the bidder drops the tender in the wrong tender box or if the tender document is handed over to the wrong person BHEL will not be responsible for any such delays.
 - d. For offers received through email/courier etc., suppliers are fully responsible for lack of secrecy on information and ensuring timely receipt of such offers in the tender box before due date & time.
 - e. In case of e-tender, all required documents should be uploaded before due date and time. Availability of power, internet connections, etc. will be the sole responsibility of the vendor. Wherever assistance is needed for submission of e-tenders, help line numbers and executives of service provider of BHEL may be contacted.
Service provider: M-junction
Website address: <https://bheleps.buyjunction.in/>
Helpline no.: 033-66106426/6217/6013/6046/6176 (9:30 am to 5:30 pm)
9163348283/9163348284/9163348285/9163348286/8584008116 (5:30 pm to 8:30 pm)

Purchase Executive / BHEL will not be responsible for any of the activities relating to submission of offer.

D. PROCESSING OFFERS RECEIVED:

1. Any discount / revised offer submitted by the supplier on its own shall be accepted provided it is received on or before the due date and time of offer submission (i.e. Part-I bid). The discount shall be applied on pro-rata basis to all items unless specified otherwise by the bidder.
2. Changes in offers or Revised offers given after Part-I bid opening shall not be considered as a part of the original offer unless such changes / revisions are requested by BHEL.
3. In case there is no change in the technical scope and / or specifications and / or commercial terms & conditions by BHEL, the supplier will not be allowed to change any of their bids after Technical bids are opened (after the due date and time of tender opening of Part-1 Bid).

4. In case of changes in scope and/ or technical specifications and/ or commercial terms & conditions by BHEL and it accounts for price implications from vendors, all techno-commercially acceptable bidders shall be asked by BHEL (after freezing the scope, technical specifications and commercial terms & conditions) to submit the impact of such changes on their price bid. Impact price will be applicable only for changes in technical specification / commercial conditions by BHEL. The impact price must be submitted on or before the cut-off date specified by BHEL and the original price bid and the price impact bid will be opened together at the time of price bid opening. Impact price means only for those items which have been impacted by addition / deletion / changes in the technical specifications or commercial conditions. The impact may be +/- incremental value of the currency in which originally quoted. The impact price bid to be submitted on the cut-off date, time & venue as specified by BHEL. The impact price bid shall be opened along with original price bid.

f

5. BHEL EDN reserves the right to adopt Reverse Auction or standard Price Bid Opening procedure for price evaluation, at its discretion. This will be decided after completion of technical evaluation of tender. **(Refer Annexure XII for Guidelines for Reverse Auction).**
6. Un-opened bids (including price bids) will be returned to the respective bidders after release of PO and receipt of order acknowledgement from the successful bidder.
7. After receipt of Purchase Order, supplier should submit required documents like drawings, bill of materials, datasheets, catalogues, quality plan, test procedure, type test report , O & M Manuals and / or any other relevant documents as per Specification / Purchase Order, as and when required by BHEL / Customer.
8. Any deviation to the terms and conditions not mentioned in the quotation by supplier in response to this enquiry will not be considered, if put forth subsequently or after issue of Purchase Order, unless clarification is sought for by BHEL EDN and agreed upon in the Purchase Order.
9. Evaluation shall be on the basis of delivered cost (i.e. "Total Cost to BHEL"). As per RFQ terms, "Total Cost to BHEL" shall include total basic cost, packing & forwarding charges, taxes and duties, freight charges, test charges, insurance, service tax for services, any other cost indicated by vendor for execution of the contract and loading factors (for non-compliance to BHEL Standard Commercial Terms & Conditions). Benefits arising out of Nil Import Duty on Mega Projects, Physical Imports or such 100% exemptions & MNRE Exemptions (statutory benefits), customer reimbursements of statutory duties (like Excise Duty, CST, VAT) will also be taken into account at the time of tender evaluation. (Wherever applicable and as indicated in SCC document of tender)
10. For evaluation of offers in foreign currency, the exchange rate (TT selling rate of SBI) shall be taken as under:

Single part bids:	Date of tender opening
Two/three part bids:	Date of Part-I bid opening
Reverse Auction:	Date of Part-I bid opening

In case of Performance Bank Guarantee (PBG) also, exchange rate will be considered as mentioned above for converting foreign currency to Indian currency and vice versa.

If the relevant day happens to be a bank holiday, then the exchange rate as on the previous working day of the bank (SBI) shall be taken.
11. Ranking (L-1, L-2 etc.) shall be done only for the techno-commercially acceptable offers and on the basis or evaluation of Total Cost to BHEL.

E. INFORMATION ON PAYMENT TERMS:

1. All payments will be through Electronic Fund transfer (EFT). Vendor has to furnish necessary details as per BHEL standard format **(Refer Annexure XI)** for receiving all payments through NEFT. (Applicable for Indian vendors only)
2. In case of High Sea Sales transaction, customs clearance of the consignment landed on Indian Sea / Air ports will be done by BHEL based on the original HSS documents provided by vendors. All warehousing charges due to delay in submission of complete and or correct HSS documents to BHEL will be to suppliers account only. Such recovery will be made out of any of the available bills.
3. Statutory deductions, if any, will be made and the deduction certificate shall be issued. In case vendor does not provide PAN details, the TDS deduction shall be at the maximum percentage stipulated as per the provisions of Income Tax Act. (Applicable for Indian vendors only).

- Foreign vendors shall submit relevant details of their bankers like Swift Code, Banker's Name & Address etc.
4. Vendors must submit bills & invoices along with required supporting documents in time. Incomplete documentation / delayed submission of invoice / documents will result in corresponding delay in payment.

F. STANDARD PAYMENT TERMS OF BHEL-EDN

Purchase Orders for indigenous procurement

(a) SUPPLY WITH E&C:

- 1) 90% of basic Supply value + 100% of taxes, duties and freight charges will be paid with 45 days credit from the receipt of material.
- 2) 10% of basic Supply value (retention money) will be paid on submission of documents as a proof of receipt against supplementary invoice with proof of completion of E&C along with E & C charges (if any)+ against submission of PBG valid for Warranty Period+6 months Claim Period from BHEL Consortium Bank.

(b) E&C/Supervision: 100% on completion of E&C/Supervision and certification line item wise on pro-rata basis.

(c) O&M: 100% O&M charges are payable as per RFQ terms against report certified by BHEL.

(c) SUPPLY ONLY:

- 1) 100% of Basic value with taxes, duties and freight will be paid with 45 days credit from the receipt of material or 15 days credit from the date of submission of complete set of documentation whichever is later)+ submission of PBG valid for Warranty Period+6 months Claim Period from BHEL Consortium Bank,if applicable.

Note: If PBG cannot not be submitted, vendors can also accept for the final 10% payment, payable after the warranty period + 6 months of claim period against supplementary invoice subject to the completion of commissioning (if applicable) as PBG is linked to Warranty period.

(d)ADVANCE PAYMENT/LC: Quotations with "Advance payment/Inland LC" shall be rejected.

(e) SALE IN TRANSIT/ LOCAL VAT: Sale in transit under section 6(2) of CST is allowed if movement of goods is interstate. In case intra state movement of goods, benefit of sale in transit is not available.

Purchase orders for import procurement:

(e) SUPPLY WITH E&C:

- 1) 90% of the basic value (excluding E&C charges) will be paid with 45 days credit, against Sight draft, from the date of AWB/BOL on submission of complete set of documents as in PO.
- 2) 10% of basic Supply value (retention money) will be paid on submission of documents as a proof of receipt against supplementary invoice with proof of completion of E&C along with E & C charges (if any)+ against submission of PBG valid for Warranty Period+6 months Claim Period from BHEL Consortium Bank.
- 3) **E&C/Supervision:** 100% on completion of E&C/Supervision and certification line item wise on pro-rata basis.

(f) SUPPLY WITH SUPERVISION OF E&C:

- 1) 90% of the value of the order will be paid with 45 days credit against Sight draft, from the date of AWB/BOL on submission of complete set of documents.
- 2) 10% of basic value (retention money) will be paid in 15 days from the date of completion of erection and commissioning against supplementary invoice with proof of completion of E&C along with supervision charges (if any).
- 3) **E&C/Supervision:** 100% on completion of E&C/Supervision and certification line item wise on pro-rata basis.

(g) SUPPLY ONLY:

- 1) 100% of PO value will be paid against Sight draft with 45 days Credit from the date of dispatch or 15 days credit from the date of submission of complete set of documents whichever is later)+ submission of PBG valid for Warranty Period+6 months Claim Period from BHEL Consortium Bank ,if applicable.

Note: If PBG cannot not be submitted, vendors can also accept for the final 10% payment, payable after the warranty period + 6 months of claim period against supplementary invoice subject to the completion of commissioning (if applicable) as PBG is linked to Warranty period.

G. LOADING FACTORS FOR PAYMENT TERMS & DELAYED DELIVERY:

Loading factors as detailed below will be added to the quoted price (basic) to evaluate the lowest quote for non-compliance of BHEL standard commercial term.

Sl No	Deviation on	Nature of Deviation / Offered Terms	Loading %
1.	Payment Terms	For Purchase within India :-	15
		1) Payment against delivery/Proforma payment against receipt of material	
		2) Payment against documents through bank – Delivery of material at site	15
		3) Credit period less than 45 days, but not less than 15 days.	10
		For Foreign Purchase :-	
		1) Payment through At Sight Letter of Credit	10
		2)Payment through Letter of Credit with usance credit of 45 days	5
	3) Sight Draft with credit period less than 45 days	5	
2.	Penalty for Delayed Delivery	1) Non – Acceptance	10
		2) Partial Acceptance (X%)	(10 – X)

* All bank charges shall be to seller's account. If bank charges of BHEL banker are to BHEL's account then **additional loading of 2% on the quoted basic value** is applicable.

NOTE: Offer/ s with payment terms other than the standard payment terms indicated at Clause No.F or Deviated Payment Terms with loading indicated at Clause No.G above are liable for rejection.

C. Non-Compliance of Warranty terms. Offers not complying with Warranty terms as per RFQ Terms is liable for rejection.

Note 1: Basic value of Purchase Order mentioned above will include all components of the purchase order and will exclude only taxes, duties, freight and E&C charges (wherever applicable).

Wherever the Purchase Order is split into import portion and indigenous portion of supply the retention money will be 15% or 10% (as applicable) of both purchase order values put together.

H. Bank guarantee (BG) / Performance bank guarantee (PBG):

1. Bank guarantee (BG) / Performance bank guarantee (PBG) will be applicable as called in the tender documents. Such PBG shall be valid for a period of Warranty Period + claim period of 6 months for a value equal to 10 % of the basic value of the purchase order. No deviation for the duration of PBG / BG will be permitted.
 - a. PBG shall be from any of the BHEL consortium of bankers (refer Annexure V).

- b. PBGs from nationalized banks are also acceptable.
 - c. PBG should be sent directly by the bank to the dealing executive mentioned in the purchase order located at the address mentioned in the purchase order. PBG should be in the format indicated. **(Refer Annexures III & IV respectively)**. No deviation to these formats will be allowed.
 - d. Confirmation from any of the BHEL consortium of banks or any of the Indian Public Sector Banks is essential for the acceptance of PBGs issued by foreign banks (located outside India).
 - e. Expired BGs / PBGs will be returned only after expiry of the claim period or on completion of the contractual obligation.
 - f. **Non-acceptance for submission of PBG will attract loading as indicated below**
 - i. Loading will be equal to the percentage of value for which BG / PBG is not provided. (Ex: if PBG / BG is given for 3 % of the basic value against 10% specified, loading applicable will be 7% (10 – 3 = 7 %). This value will be added to the quoted price while evaluating the lowest offer.
- I. Documents required at the time of dispatch for processing of Bills:
- i. **For Supply:** Invoice in Triplicate, LR Copy, Packing List, PSI Call Letter Copy & Warranty Certificate
 - ii. **For E&C:** Supplementary Invoice in Triplicate with copy of E&C Certificate (Proof of Completion of E&C)
 - iii. **For PBG:** Supplementary Invoice in Triplicate with copy of PBG. However, PBG should come to us directly from the Bank.

J. PROVISIONS APPLICABLE FOR MSE VENDORS (MICRO AND SMALL ENTERPRISES)

Vendors who qualify as MSE vendors are requested to submit applicable certificates (as specified by the Ministry of Micro, Small and Medium Enterprises) at the time of vendor registration. Vendors have to submit any of the following documents along with the tender documents in the Part I / Technical bid cover to avail the applicable benefits.

- a. Valid NSIC certificate or
- b. Entrepreneur's Memorandum part II (EM II) certificate (deemed valid for 2 years).
- c. EM II certificate with CA certificate **(in the prescribed format given in Annexure IX)** applicable for the year certifying that the investment in plant and machinery of the vendor is within permissible limits as per the MSME Act 2006 for relevant status where the deemed validity is over.
- d. Documents submitted for establishing the credentials of MSE vendors must be valid as on the date of part I / technical bid opening for the vendors to be eligible for the benefits applicable for MSE vendors. Documents submitted after the Part I / Technical bid opening date will not be considered for this tender.

PURCHASE PREFERENCE FOR MSE VENDORS:

- e. MSE vendors quoting within a price band of L1 + 15% shall be allowed to supply up to 20% of the requirement against this tender provided.
 - 1. The MSE vendor matches the L1 price
 - 2. L1 price is from a non MSE vendor
 - 3. L1 price will be offered to the nearest vendor nearest to L1 in terms of price ranking (L2 - nearest to L1). In case of non-acceptance by the MSE vendor (L2) next ranking MSE vendor will be offered who is within the L1 + 15% band (if L3 is also within 15% band).
 - 4. 20% of the 20% (i.e. 4% of the total enquired quantity) will be earmarked for SC/ST owned MSE firms provided conditions as mentioned in (1) and (2) are fulfilled.
 - 5. In case no vendor under SC / ST category firms are meeting the conditions mentioned in (1) and (2) or have not participated in the tender, in such cases the 4% quantity will be distributed among the other eligible MSE vendors who have participated in the tender.
 - 6. Serial no. 1 to 5 will not be applicable wherever it is not possible to split the tendered quantity / items on account of customer contract requirement, or the items tendered are systems. Such information that tendered quantity will not be split will be indicated in the SCC.

K. INTEGRITY COMMITMENT IN THE TENDER PROCESS, AND EXECUTION OF CONTRACTS:

1. Commitment by BHEL:

BHEL commits to take all measures necessary to prevent corruption in connection with the Tender process and execution of the Contract. BHEL will, during the tender process, treat all bidder / suppliers in a transparent and fair manner, and with equity.

2. Commitment by Bidder(s)/ Contractor(s):

- a. The Bidder(s)/ Contractor(s) commit(s) to take all measures to prevent corruption and will not directly or indirectly try to influence any decision or benefit which he is not legally entitled to.
- b. The Bidder(s)/ Contractor(s) will not enter with other Bidder(s) into any undisclosed agreement or understanding or any actions to restrict competition.
- c. The Bidder(s)/ Contractor(s) will not commit any offence under the relevant Acts. The Bidder(s)/ Contractor(s) will not use improperly, for purposes of competition or personal gain or pass on to others, any information or document provided by BHEL as part of business relationship.
- d. The Bidder(s)/ Contractor(s) will, when presenting his bid, disclose any and all payments he has made, and is committed to or intends to make to agents, brokers or any other intermediaries in connection with the award of the contract and shall adhere to the relevant guidelines issued from time to time by Government of India/ BHEL.

If the Bidder(s) / Contractor(s), before award or during execution of the Contract commit(s) a transgression of the above or in any other manner such as to put his reliability or credibility in question, BHEL is entitled to disqualify the Bidder(s) / Contractor (s) from the tender process or terminate the contract and/ or take suitable action as deemed fit.

PURCHASE EXECUTIVE



PURCHASE SPECIFICATION, GROUP : PHOTOVOLTAICS
SUPPLY OF MMS FOR 1 MW SPV PLANT AT NREDCAP
Bhimavaram Rural Mandal, West Godavari District, Andhra Pradesh

PS-439-983
REV NO: 00
PAGE : 1 OF 4

COPYRIGHT AND CONFIDENTIAL

The information on this document is the property of Bharat Heavy Electricals Limited.

It must not be used directly or indirectly in anyway detrimental to the interest to the company

Technical Specification
For
SUPPLY OF MODULE MOUNTING STRUCTURES FOR 1MW SOLAR PHOTOVOLTAIC POWER PLANT AT
Bhimavaram Rural Mandal, West Godavari District, Andhra Pradesh.

Revision details :R 00	Prepared PM	Approved MS	Date 24.8.2015
------------------------	----------------	----------------	-------------------

	PURCHASE SPECIFICATION, GROUP : PHOTOVOLTAICS	PS-439-983
	SUPPLY OF MMS FOR 1 MW SPV PLANT AT NREDCAP	REV NO: 00
	Bhimavaram Rural Mandal, West Godavari District, Andhra Pradesh	PAGE : 2 OF 4

1.0 Introduction:

Bharat Heavy Electricals Limited (BHEL), Electronics Division, Bangalore is setting up 1MWp Grid-connected SPV Power Plant at NREDCAP Bhimavaram Rural Mandal, West Godavari District(A.P).

This document describes the technical specification for the Module Mounting Structures (MMS) that constitute the solar array of the plant. MMS are steel structures over which solar PV modules are mounted.

2.0 Pre-Qualification Criteria

- 2.1 Bidder shall have in-house facilities with minimum capacity of 50 MT per month for fabrication of steel structures. Delivery challans shall be furnished for at least 3 months within the past one year Aug '14 – Jul '15, showing minimum 50 MT each month. BHEL reserves the right to inspect the works in case required. Vendor shall indicate the address of the works.
- 2.2 Bidder shall have ISO 9001 certification with validity as on tender opening date. Bidder shall enclose ISO 9001 certificate along with part-I bid. Alternatively, the bidder shall be an approved vendor of any BHEL unit for steel structure fabrication. This shall be substantiated by submitting copy of POs/Work orders for steel structures during the last three years from date of this tender.
- 2.3 Vendors shall furnish the solvency certificate issued by nationalized/ scheduled banks for minimum worth of Rs 60 lakhs, with date of issue not before 3 months from tender opening date.

3.0 Vendor scope of supply

#	Item description	Qty	Unit	Material specification
1	Module Mounting structure- Purlin as per drawing No 16790500063 , Weight of each purlin is approx. 0.38 MT	280	No	As per Drawing.
2	Module Mounting structure- Girder as per drawing No 16790500064 , Weight of each Girder is approx. 0.318 MT	280	No	As per Drawing.
3	Module Mounting structures -SS M6 Hardware Sets- as per BOM of drawing 16790500065. Total Weight of complete set of SS hardware is approx. 0.4 MT	1	Set	SS304 and Class A2-70
4	Module Mounting structures miscellaneous items as per drawing no 16790500065 , Total weight of complete set is approx. 29 MT	1	Set	As per Drawing.
5	Warranty: 12 months from the date of commissioning or 18 months from date of supply which earlier.	-		-

4.0 Important note for Vendor scope of supply:

	PURCHASE SPECIFICATION, GROUP : PHOTOVOLTAICS	PS-439-983
	SUPPLY OF MMS FOR 1 MW SPV PLANT AT NREDCAP	REV NO: 00
	Bhimavaram Rural Mandal, West Godavari District, Andhra Pradesh	PAGE : 3 OF 4

The scope of supply includes Purlin as per drawing No 16790500063 which is 12.3 m long welded structure. For the sake of galvanizing convenience this 12.33 m long purlin has been split up into 8m long and 4.33 m long structures.

Vendors have got 2 Alternatives routes to follows.

Alternative 1.

Vendor can join the purlin with bolts and welding and painting at the welded area as per technical requirement 01 of drawing 16790500063 and dispatch at 12.33 m long structures.

Alternative 2

Vendor can dispatch the purlins as loose pieces of 8m and 4.33 m long pieces after putting proper match marking lines and Sl.no for easy correlation at site. Vendor has to organize for bolting ,welding and painting of welded area at site.

Vendors will be evaluated on landed cost at site in the fully assembled , welded and painted condition.

Delivery for Alternative 2 will be reckoned on the date when fully assembled , welded and painted purlins are handed over to BHEL site office.

5.0 Instructions to vendors on bid submission

5.1	Offer shall be submitted in two-parts (Two part-bid). Both parts shall be in separate sealed envelopes as per instructions in tender. The individual envelopes shall be enclosed in a common bigger envelope with markings on the envelope (address, etc) as per instructions provided in tender.
5.2	First-part shall be Technical bid . Following details shall be furnished: 1. Technical offer covering letter. 2. Filled-up enclosures as per BHEL tender formats (for first-part technical bid). 3. Separate clause-wise deviation sheet in case of deviations from BHEL spec.
5.3	Second-part shall be Price bid with filled up enclosures as per BHEL tender format.
5.4	In addition to the above instructions, tender document provides detailed instructions for bid submission. Vendor shall submit the bid based on such tender instructions.

6.0 Enclosures to this tender

- (a) BHEL drawing nos 16790500062, 16790500063, 16790500064, 16790500065.
- (b) Pre-Qualification Criteria (Clause 2.0 of this specification)
- (c) Typical sample MQP for reference purpose.
- (d) RFQ tender documents with formats to be filled etc.

7.0 Manufacturing Quality Plan (MQP)

	PURCHASE SPECIFICATION, GROUP : PHOTOVOLTAICS	PS-439-983
	SUPPLY OF MMS FOR 1 MW SPV PLANT AT NREDCAP	REV NO: 00
	Bhimavaram Rural Mandal, West Godavari District, Andhra Pradesh	PAGE : 4 OF 4

A typical sample of MQP for the MMS items is enclosed along with this tender. Vendor shall use this document as reference for preparation and submission of MQP to BHEL for approval.

8.0 Test reports

For every lot of dispatch, vendor shall submit MTC and other test reports as per MQP.

9.0 Packing instructions:

For SS Hardwares and Standard MS hardwares :

The above shall be supplied in plastic wrapped hessian cartons/plastic wrapped thick cardboard cartons to avoid bursting and spillage of contents during transport and storage at site. Each carton shall be clearly identified with the type and quantity of hardware. Cartons shall be in weight not exceeding 30 kg per carton for easy handling and storage at site.

Packing instructions for all other items to be as mentioned in relevant drawings.

10.0 Documents to be submitted after receipt of purchase order for BHEL-EDN approval:

BHEL approval shall be obtained for the following technical documents, which shall be submitted within **seven** days from the date of purchase order:

10.1	Detailed delivery schedule.	
------	-----------------------------	--

11.0 Pre-dispatch inspection of vendor supplied items

11.1	A prototype MMS structure has to be made and inspected by BHEL-EDN personnel. The inspection shall be carried out at pre-galvanized assembled stage and post galvanized stage. Subsequent to the clearance of the above prototype structure only, bulk manufacture of MMS structure shall commence.	
11.2	Vendor shall provide pre-dispatch inspection call to BHEL-EDN for inspection at manufacturer works, as per BHEL-EDN approved drawings, for all fabricated items such as steel structure members, galvanization process etc. Prior to inviting BHEL-EDN for pre-dispatch inspection, vendor shall submit detailed quality assurance plan (QAP) for BHEL-EDN approval in accordance with BHEL QP attached. After the inspection, complete set of test reports shall be submitted.	
11.3	For all bought-out items, test certificates as per relevant standards shall be submitted.	

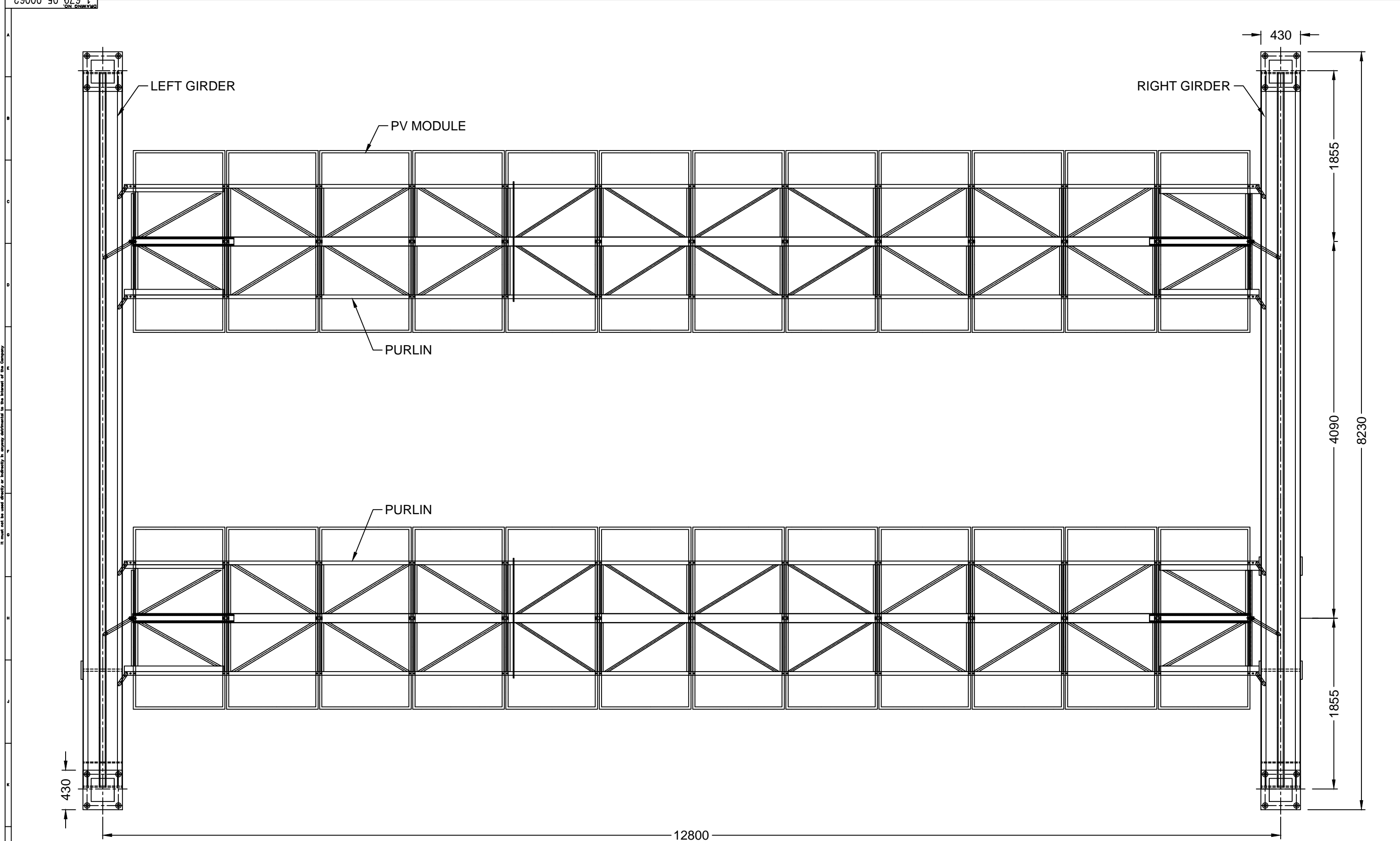

TECHNICAL REQUIREMENT

1. PURLIN AND GIRDER ARE CONNECTED BY ITEMS AS PER 1-679-05-00065.
2. BEFORE DISPATCH PROOF ASSEMBLY OF ALL SETS OF PURLINS AND GIRDERS IS TO BE CARRIED OUT. EACH SET COMPRISES OF 2 PURLINS AND 2 GIRDERS (ONE LEFT HAND AND ONE RIGHT HAND).
3. FOR DETAILED DRAWING OF PURLIN REFER DRAWING NO. 1-679-05-00063 & FOR GIRDER REFER DRAWING NO. 1-679-05-00064.

ITEM NO.	DESCRIPTION	DRAWING NO.	ITEM NO.	MATERIAL CODE

PRODUCT : 1MWp SPV POWER PLANT
 CUSTOMER : NREDCAP, BYM

DRW	NAME	SIGN.	DA

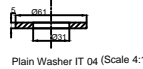
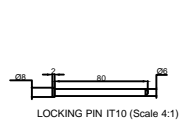
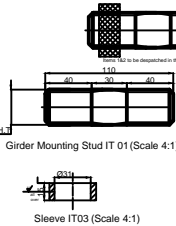
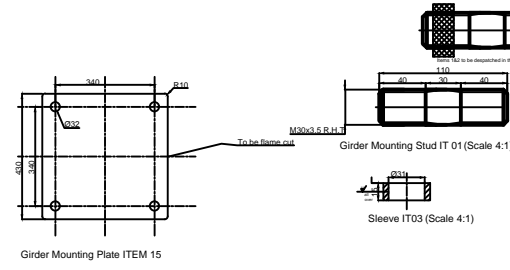
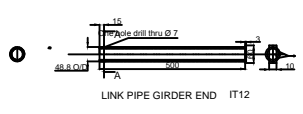
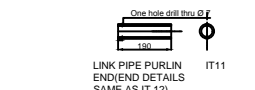
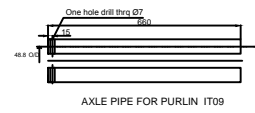
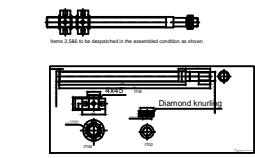
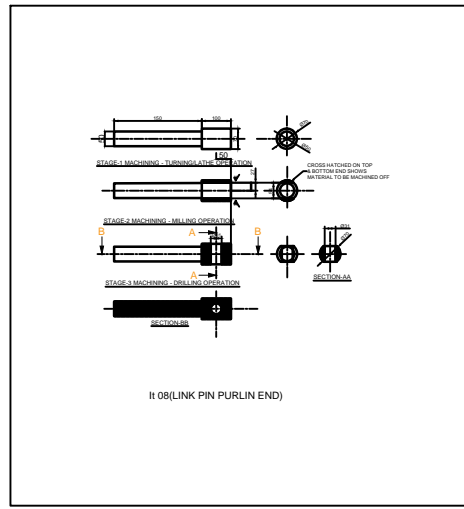
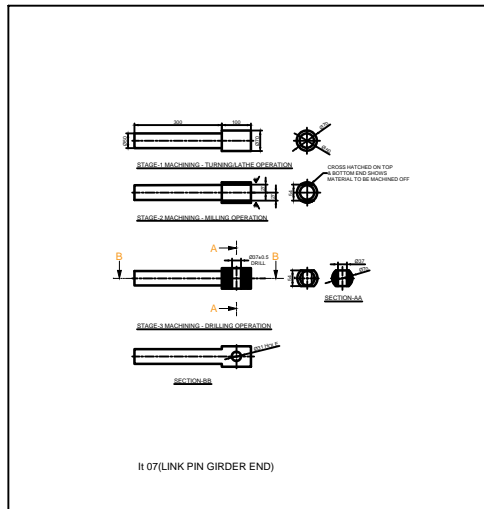
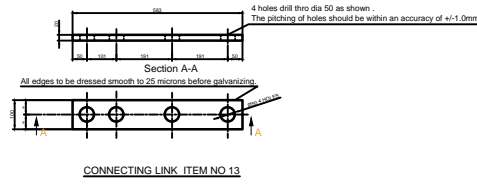

PLEASE REFER THE ATTACHED EXCEL BOM

PART NO.	NAME	GRADE	QTY IN NOS.	Wt. in Kgs.
16	M6X20 BOLT+NUT+WASHER	-	AS PER BOM	
15	GIRDER PLATE MOUNTING	-	4	
14	STRIPS FOR HOLDING GIRDER	-	AS PER BOM	
13	CONNECTING LINK	-	4	
12	LINK PIPE GIRDER END	-	4	
11	LINK PIPE PURLIN END	-	4	
10	LOCKING PIN	-	12	
9	AXLE PIPE FOR PURLIN	-	4	
8	LINK PIN PURLIN END	-	4	
7	LINK PIN GIRDER END	-	4	
6	M36 ROUND NUT	-	8	
5	LINK ROD	-	4	
4	PLAIN WASHER		16	
3	SLEEVE		16	
2	M30 ROUND NUT		32	
1	MOUNTING STUD M30		16	

BOM OF BHIMAVARAM

Technical requirement:
1.All hardwares to be hot dip galvanized as per IS 1367 part 1 and 13 and class to be 4.8.

NREDGAP-3 MW BHIMAVARAM BOM For Misc Items						
Item No	Item Description	Trade/Stage	Grade	Std. unit	No. of 1	Total wt
1	Mounting Stud M30			mm	16	138.8
2	Round nut M30			mm	32	138.8
3	Sleeve			mm	16	138.8
4	Plain Washer			mm	16	138.8
5	Link Rod			mm	4	138.8
6	M36 Round Nut			mm	8	138.8
7	Link pin girder end			mm	4	138.8
8	Link pin purlin end			mm	4	138.8
9	Axle pipe for purlin (4.80) 4.00%			mm	4	138.8
10	Locking pin			mm	12	138.8
11	Link pipe girder end (4.80) 4.00%			mm	4	138.8
12	Link pipe purlin end (4.80) 4.00%			mm	4	138.8
13	Connecting link			mm	4	138.8
14	Girder mounting plate			mm	4	138.8
15	Girder mounting plate			mm	4	138.8
Total weight for 1 set						2364.03
55 HARDWARE						
Item No	Item Description	Trade/Stage	Grade	Std. unit	No. of 1	Total wt
16	M6X20 Bolt+Nut+Washer (IS 1367 part 1 and 13 and class 4.8)			mm	2000	433.0
Total weight for misc items for 1 set						3098.3

ITEM NO.	DESCRIPTION	DRAWING NO.	ITEM QTY.	MATERIAL CODE	QTY.	Wt. in Kgs.
CARD TYPE 2						
NAME OF CUSTOMER/PROJECT						
I MW SPV PLANT AT BHIMAVARAM						
SUNAT HEAVY ELECTRICALS LIMITED, BHIMAVARAM						
DATE	SCALE	DESIGNER	REF. TO ASSY. DRG.	ITEM NO.	REV. NO.	
00	NTS			00	00	
DRAWING NO. 1 679 05 00062						
SHEET NO. 01 OF SHEETS 01						

THE INFORMATION ON THIS DRAWING IS UNCLASSIFIED AND IS NOT TO BE RELEASED TO THE PUBLIC WITHOUT THE WRITTEN AUTHORIZATION OF THE COMPANY. IT IS THE PROPERTY OF SUNAT HEAVY ELECTRICALS LIMITED.

MANUFACTURING QUALITY PLAN (MQP)													
		ITEM :	MODULE MOUNTING STRUCTURE FOR SPV PLANT			PROJECT NAME:	1MWp Solar PV power plant at Bhimavaram						
		MQP NO.:				CONTRACT NO.:							
		REV. NO.:				CONTRACTOR:							
		DATE :				CUSTOMER :	BHEL						
Sr. No.	Component & Operation	Characteristics	Class	Typ of Check	Quantum of Check		Reference Document	Acceptance Norms	Format of Record		Agency		Remarks
					M	C				D	M	C	
1	2	3	4	5	6	7	8	9	10	11	12	13	14
STRUCTURES													
RAW MATERIAL													
1.1	Hot Rolled Structures Steel-As per BOM	a) Chemical Composition	Major	Chemical	1 Sample/40 MT or Part thereof for each class of Product.	Each lot	Approved. Drg IS: 2062-2011 IS: 8500-1991 IS: 228-1987 IS: 1608-2005 IS: 1599-1983	Approved. Drg IS: 2062-2011 IS: 8500-1991 IS: 228-1987 IS: 1608-1995 IS: 1599-1983	Procedure's/ fabricator's Certificate/ Check Test Reports	√	V	V	IS:2062-2011/Material Grade referred as per drawing/BOM shall be used. All tolerances as per relevant code/Tech Spec/drawing
		b) Tensile Test(TS, YS %Elongation)	Major	Mech.	1 Sample/40 MT or Part thereof for each class of Product.	Each lot	Approved. Drg IS: 2062-2011 IS: 8500-1991 IS: 228-1987 IS: 1608-2005 IS: 1599-1983	Approved. Drg IS: 2062-2011 IS: 8500-1991 IS: 228-1987 IS: 1608-1995 IS: 1599-1983	Procedure's/ fabricator's Certificate/ Check Test Reports	√	V	V	
		c) Bend Test	Major	Mech.	1 Sample/40 MT or Part thereof for each class of Product.	Each lot	Approved. Drg IS: 2062-2011 IS: 8500-1991 IS: 228-1987 IS: 1608-2005 IS: 1599-1983	Approved. Drg IS: 2062-2011 IS: 8500-1991 IS: 228-1987 IS: 1608-1995 IS: 1599-1983	Procedure's/ fabricator's Certificate/ Check Test Reports	√	V	V	
		d) Visual Check for Surface	Major	Visual	100%	Each lot	Approved. Drg IS: 2062-2011 IS: 8500-1991 IS: 228-1987 IS: 1608-2005 IS: 1599-1983	Approved. Drg IS: 2062-2011 IS: 8500-1991 IS: 228-1987 IS: 1608-1995 IS: 1599-1983	Procedure's Inspection Report	√	P	V	
		e)Dimension	Major	Measure	As per IS:2500-1992 SSP Level -1 AQL 6.5	Random for each lot	IS:808-1989 (Angles) IS:1852-1985 (Plates) IS:1730-P-1-1989 IS: 2062-2011	IS:808-1989 (Angles) IS:1852-1985 (Plates) IS:1730-P-1-1989 IS: 2062-2011	Fabricator's Inspection Report	√	P	V	
1.3	Zinc	Chemical Composition	Major	Measure	1 Sample/lot	Random for each lot	IS:209-1992	IS:209-1992 Zn-99.5%	Procedure's TC/ Check Test Report	√	P	V	
IN PROCESS INSPECTION													
2.1	Fabrication of parts of assy.	a)Straightening	Major	Visual	100%	Random for each lot	IS:802-P-11-1978	IS:802-P-11-1978	Fabricator's Inspection Report	√	P	V	
		b)Cropping (Cutting)	Major	Visual	1st piece & every 100th piece	Random for each lot	Approved drgs. Shop Sketches	Approved Drgs./Tech. Spec.	Fabricator's Inspection Report	√	P	V	
		c)Stamping (identification-mark Number)	Major	Visual	100%	Random for each lot	Approved Drgs./ Tech. Spec.	Approved Drgs./Tech. Spec.	Fabricator's Inspection Report	√	P	V	
		d) Making hole by Punching/Drilling.	Major	Measure	1st piece & every 100th piece	Random for each lot	IS:802-P-11:1978	Holes should be perpendicular to surface & difference in dia. Of holes on the two sides of plates / angle should not be more than 0.8mm. Holes near bends to be punched/ drilled.	Fabricator's Inspection Report	√	P	V	Punching may be adopted for section upto 12mm thick. For thicker drilling to be done
		e) Edge Security	Major	Measure	1st piece & every 100th piece	Random for each lot	IS:802-P-11:1978	IS:802-P-II:1978 Table. 1	Fabricator's Inspection Report	√	P	V	
		f)Hole to Hole Distance	Major	Measure	1st piece & every 100th piece	Random for each lot	IS:802-P-11:1978	Tolerance cumulative # 2mm & between consecutive hole #1mm	Fabricator's Inspection Report	√	P	V	
		g)Overall length of members	Major	Measure	1st piece & every 100th piece	Random for each lot	IS:802-P-11:1978	Tolerance #2mm	Fabricator's Inspection Report	√	P	V	
		h) Gauge Distance	Major	Measure	1st piece & every 100th piece	Random for each lot	IS:802-P-11:1978	Tolerance # 1mm	Fabricator's Inspection Report	√	P	V	
		i) Notching flange cut, corner cut & level cut	Major	Measure	1st piece & every 100th piece	Random for each lot	IS:802-P-11:1978	5mm on specified length of cut operation by shearing up to 12mm thick & by gas cutting for material above 12mm thick/IS:802-P-II:1978 Table. 1	Fabricator's Inspection Report	√	P	V	
		j) Heel Grinding	Major	Measure	1st piece & every 100th piece	Random for each lot	IS:802-P-11:1978	After Grinding thickness on heel should be equal or more than the thickness of the member with +2mm/.0mm/ as per spec.	Fabricator's Inspection Report	√	P	V	
		m) Other Dimension	Major	Measure	1st piece & every 100th piece	Random for each lot	IS:802-P-11:1978/ IS:7215-1974	IS:7215-1974	Fabricator's Inspection Report	√	P	V	
GALVANIZING													
2.31	Degreasing (Acid base)	a)Solution Strength	Major	Visual	1 Sample Daily	Random for each lot	IS:2629-1985	IS:2629-1985	Galvanizer QC Records	√	P	V	
		b)PH Value	Major	Chem.	1 Sample Daily	Random for each lot	IS:2629-1985	IS:2629-1985	Galvanizer QC Records	√	P	V	
2.32	Rinsing	a)Cleanliness	Major	Visual	1 Sample Daily	Random for each lot	IS:2629-1985	IS:2629-1985	Galvanizer QC Records	√	P	V	
2.33	Pickling	a)Acid Content	Major	Chem.	1 Sample Daily	Random for each lot	IS:2629-1985	IS:2629-1985	Galvanizer QC Records	√	P	V	
		b)Iron Content	Major	Chem.	1 Sample Daily	Random for each lot	IS:2629-1985	IS:2629-1985	Galvanizer QC Records	√	P	V	
2.34	Rinsing	Cleanliness (Mill Scale paint marks etc.)	Major	Chem.	1 Sample Daily	Random for each lot	IS:2629-1985	IS:2629-1985	Galvanizer QC Records	√	P	V	
2.35	Pre-Fluxing	a)Dry Fluxing	Major	Chem.	1 Sample Daily	Random	IS:2629-1985	IS:2629-1985	Galvanizer QC Records	√	P	V	Pre-Fluxing in Zinc Chlorides & ammonium chloride solution.
		b)Iron Content	Major	Chem.	1 Sample Daily	Random	IS:2629-1985	IS:2629-1985	Galvanizer QC Records	√	P	V	
		c)Specific Gravity	Major	Chem.	1 Sample Daily	Random	IS:2629-1985	50gm/Ltr. Max 1.11 to 1.30	Galvanizer QC Records	√	P	V	
		d)pH Value	Major	Chem.	1 Sample Daily	Random	IS:2629-1985	4 to 5	Galvanizer QC Records	√	P	V	
		e)Temperature	Major	Measure	Hourly	Random	IS:2629-1985	IS:2629-1985	Galvanizer QC Records	√	P	V	
2.36	Pre Heating	Temperature	Major	Measure	Hourly	Random	IS:2629-1985	IS:2629-1985	Galvanizer QC Records	√	P	V	Calibrated Instrument to be used.
2.37	Hot Dip Galvanizing	a)Temperature	Major	Measure	Continuous recording & hourly measurement	Random	IS:2629:1985	440 to 460 deg. Celsius	Galvanizer's QC Records.	√	P	V	Zinc Bath temperature to be recorded continuously on graph & hourly manual recording shall also be done using digital temp. indicator & actual verification by thermometer.
		b)immersion time	Major	Measure	Each Lot	Random	IS:2629-1985	IS:2629-1985	Galvanizer's QC Records.	√	P	V	
		c) Removal of excessive zinc while lifting from zinc bath by bumping process.	Major	Measure	Each Item	Random	IS:2629-1985	IS:2629-1985	Galvanizer's QC Records.	√	P	V	Wiping & scrapping process not to be used.
2.38	Quenching or Running Water	Cooling & cleaning.	Major	Measure	Each Item	Random	IS:2629-1985	IS:2629-1985	Galvanizer's QC Records.	√	P	V	
2.39	Post Treatment or Dichromating.	Solution Strength	Major	Chem.	Once in day	Random	IS:2629-1985	IS:2629-1985	Galvanizer's QC Records.	√	P	V	
2.4	Check on member after galvanizing.	a) Surface Defect & Finish.	Major	Visual	100%	Random	IS:2629-1985	IS:2629-1985	Galvanizer's QC Records.	√	P	V	
		b) Thickness of Zinc Coating.	Major	Measure	Each Batch	Random	IS:4759:1996	IS:4759:1996	Galvanizer's QC Records.	√	P	V	
		c) Mass of Zinc Coating	Major	Chem.	1 Sample/ Shift	Random	IS:4759:1996	IS:4759:1996	Galvanizer's QC Records.	√	P	V	
		d) Uniformity of zinc coating (Preece Test)	Major	Chem.	Sample/ Shift	Random	IS:2633:1986	IS:2633:1986	Galvanizer's QC Records.	√	P	V	
		e) Adhesion test of zinc coating (Pivot Hammer Test/Knife Test)	Major	Chem.	Sample/ Shift	Random	IS:2633:1986	No Removal or Lifting of Coating between hammer impression/ coating should not be peeled off.	Galvanizer's QC Records	√	P	V	
2.41	Stenciling of Mark/Number	Marking	Major	Visual	100%	Random	Approved Drg.	Approved Drg.	Galvanizer's QC Records	√	P	V	At Both Ends with black Paint

MANUFACTURING QUALITY PLAN (MQP)													
			ITEM : MODULE MOUNTING STRUCTURE FOR SPV PLANT			PROJECT NAME: 1MWp Solar PV power plant at Bhimavaram							
			MQP NO.:			CONTRACT NO.:							
			REV. NO.:			CONTRACTOR:							
			DATE :			CUSTOMER :			BHEL				
Sr. No.	Component & Operation	Characteristics	Class	Typ of Check	Quantum of Check		Reference Document	Acceptance Norms	Format of Record		Agency		Remarks
					M	C				D	M	C	
1	2	3	4	5	6	7	8	9	10	11	12	13	14
3	FINAL INSPECTION												
3.1	Fabrication Member after Galvanizing	a)Surface Finish, Defects & dichromating.	Major	Visual	100%	Random for each lot as per IS 2500 for reduced inspection	IS:2629:1985	IS:2629:1985	Final Inspection Report	√	P	W	Test qty./ sample no.s shall be as per offered lot size and IS:2500 for reduced inspection level S-4- to be fixed at time of offering.
		b)Dimensions	Major	Measure	Random Sample from Each lot offered for inspection on single occasion	Random for each lot as per IS 2500 for reduced inspection	IS:4759:1996 IS:802-P-1:1978	IS:4759:1996 IS:802-P-1:1978		√	P	W	
3.2	Verification of basic material quality	a)Chemical Composition	Major	Chem.	Random sample from each lot offered for inspection on single occasion.	Random for each lot as per IS 2500 for reduced inspection	Approved Drg. IS:2062:1992 IS:8500:1991 IS:228:1987 IS:1608:1995 IS:1599:1985	Approved Drg. IS:2062:1992 IS:8500:1991 IS:228:1987 IS:1608:1995 IS:1599:1985	Fabricator's Test Reports	√	P	V	Sample for chemical test to be sealed for third party lab or test to be witnessed at manufacturer's lab depending on availability of apparatus.
		b)Tensile Test (TS,YS,%E)	Major	Mech.	Random sample from each lot offered for inspection on single occasion.	Random for each lot as per IS 2500 for reduced inspection	Approved Drg. IS:2062:1992 IS:8500:1991 IS:228:1987 IS:1608:1995 IS:1599:1985	Approved Drg. IS:2062:1992 IS:8500:1991 IS:228:1987 IS:1608:1995 IS:1599:1985	Fabricator's Test Reports	√	P	W	
		c)Bend Test	Major	Mech.	Random sample from each lot offered for inspection on single occasion.	Random for each lot as per IS 2500 for reduced inspection	Approved Drg. IS:2062:1992 IS:8500:1991 IS:228:1987 IS:1608:1995 IS:1599:1985	Approved Drg. IS:2062:1992 IS:8500:1991 IS:228:1987 IS:1608:1995 IS:1599:1985	Fabricator's Test Reports	√	P	W	
3.3	Fillet Welding Quality	Weld Quality	Major	Visual	100%	Random for each lot as per IS 2500 for reduced inspection	IS:822:1970 & As per Approved Drg.	IS:822:1970 & As per Approved Drg.	Fabricator's Test Reports	√	P	W	W=Random10%. Butt weld not permitted.
3.4	Galvanizing	a)Thickness of Zinc Coating	Critical	Measure	Random	Random for each lot as per IS 2500 for reduced inspection	IS:2629:1985/ As per tech. spec.	IS:2629:1985/ As per tech. spec.	Fabricator's QC Reports	√	P	W	
		b)Mass of Zinc coating	Critical	Measure	Sample/ each thickness offered for insp. on single occasion	Random for each lot as per IS 2500 for reduced inspection	IS:6745:1972/ As per tech spec.	IS:6745:1972/ As per tech spec.	Fabricator's QC Reports	√	P	W	
		c)Uniformity of Zinc Coating	Critical	Measure	Sample/ each thickness offered for insp. on single occasion	Random for each lot as per IS 2500 for reduced inspection	IS:2633:1986/ As per tech spec.	IS:2633:1986/ As per tech spec.	Fabricator's QC Reports	√	P	W	
		d)Adhesion Test of Zinc Coating (Pivot Hammer/Knife Test)	Critical	Measure	Sample/ each thickness offered for insp. on single occasion	Random for each lot as per IS 2500 for reduced inspection	IS:2629:1985	IS:2629:1985	Fabricator's QC Reports	√	P	W	
3.5	Review of Documents (TC/TR)	a)Document Review	Major	Review		Random	As Applicable	As Applicable	As Per QA Plan	√	P	V	
4	PACKING STORING /BUNDLING & HANDLING	Packing	Major	Visual	Every Lot	Random	IS:802-P-1:1978	Piece of light sections to wire bundled & heavy sections to be supplied loose. Stacking to have proper ventilation.	As Per QA plan	√	P	V	1)Sequential supplies to be monitored & assured by main contractor.
5	DESPATCH	a)Sequential supplies b)Stenciling/Part No. c)Quality	Major	Review	As per packing List	Random	Appd. Drgs. & BOM	Appd. Drgs. & BOM	Fabricator's Dispatch Records	√	P	V	2)Material rejected by Customer shall be kept under separated custody marked with plant till all the supplies are dispatched to site or destroyed by cutting Presence of Customer Representative.

LEGEND:
M: MANUFACTURER/SUB-SUPPLIER
C:BHEL
D:DOCUMENT
P:PERFORM
W:WITNESS
V: VERIFICATION

MANUFACTURER/SUB-SUPPLIER

CONTRACTOR



TOTAL WEIGHT OF MMS STRUCTURE IS 220 MT (THIS INCLUDES 280 PANEL PURLIN+280 GIRDERS+1SET OF MISC ITEMS) Details below

NREDCAP-1 MW BHIMAVARAM BOM For Panel Purlin								
Mark No	Item Description	Profile Shape	Grade	Thickness	Nos.	Length	Unit/Wt	Total wt.
	HOT ROLLED SECTION			mm		mm	kg/m OR kg/m²	kg
1	ISA 40X40X5	Equal Angle	FY250	5	2	12330	2.97	73.2
2	ISMC100	C Channel	FY250	5	1	12150	9.18	111.6
3	PIP269H (Hor.)	Pipe O.D-26.9mm	FY250	3.2	13	1160	1.87	28.2
4	PIP269H (Ver.)	Pipe O.D-26.9mm	FY250	3.2	22	700	1.87	28.8
5	PIP269H (Incl.)	Pipe O.D-26.9mm	FY250	3.2	8	1270	1.87	19.0
6	PIP337M (Incl.)	Pipe O.D-33.7mm	FY250	3.2	16	1270	2.41	49.0
7	PIP337M (Ver.)	Pipe O.D-33.7mm	FY250	3.2	4	640	2.41	6.2
8	Plate 70mmx30mm	Rectangular plate	FY250	5	13	70	1.18	1.1
9	Plate 1100mmx18mmx5mm thk	Rectangular plate	FY250	5	4	1100	0.71	3.1
10	TUB60604	60mm Square tube	FY250	3.2	4	1080	4.39	19.0
11	TUB60604	60mm Square tube	FY250	3.2	2	1100	4.39	9.7
12	Purlin splice ISA 50X50X5 (Hor.)	Equal Angle	FY250	5	2	1300	3.76	9.8
13	Purlin splice plate 200mmx60mmx5mm thk	Rectangular plate	FY250	5	2	200	2.36	0.9
14	3 mm dia rod		FY250		26		0.00	0.1
15	M10X30 Bolt +Nut and washer		HDG as per IS 1367 part 1&13 Class 4.8		6		0.13	0.8
16	stiffner (150x70x5)		FY250		8		0.21	1.7
								361.8
								101312.4
NREDCAP-1 MW BHIMAVARAM BOM For Girder								
Mark No	Item Description	Profile Shape	Grade	Thickness	Nos.	Length	Unit/Wt	Total wt.
	HOT ROLLED SECTION			mm		mm	kg/m OR kg/m²	kg
1	Angle iron (55x55x5)			5	2	7780	31.898	63.796
2	ISMC(75x40)				1	7780	55.55	55.55
3	Mounting plate (290x430x12)				2		11.76	23.52
4	Rib			12	4		3.7	14.8
5	Stiffner plate(250x423)			12	4		9.974	39.896
6	Square tube (60x60x4)			4	2		1.95	3.9
7	Bottom rib (35x210)			5	2		0.29	0.58
8	Top & end rib(45x50)			5	2		0.088	0.176
9	Mid Rib			5	2		0.623	1.246
10	End Plate (70x100)			5	2		0.275	0.55
11	Connecting Lug			20	8		5.266	42.128
12	40x40x3			3	1		2.88	2.88
13	50x50x5			5	1	3000	10.2	10.2
14	Pipe33.7	Pipe O.D-33.7mm		3.2		4000	9.64	9.64
15	Pipe26.9	Pipe O.D-26.9mm		3.2		4000	7.48	7.48
16	Pipe21.3	Pipe O.D-21.3mm		3.2		14000	20.02	20.02
17	SQUARE tube (25X3.2)			3.2		6000	11.88	11.88
18	WELD							10
								318.242
								89107.76
NREDCAP-1 MW BHIMAVARAM BOM For Misc items								
Mark No	Item Description	Profile Shape	Grade	Thickness	Nos. for 1 set	Length	Unit/Wt	Total wt. for 1 set
				mm		mm	kg/m OR kg/m²	kg
1	Mounting Stud M30		IS 2062-2011Gr E250		1180		0.61	719.8
2	Round nut M30		IS 2062-2011Gr E250		2910		0.30	873
3	Sleeve		IS 2062-2011Gr E250		1180		0.14	165.2
4	Plain washer		IS 2062-2011Gr E250		1180		0.08	96
5	Link Rod		IS 2062-2011Gr E250		570		4.30	2451
6	M36 Round Nut		IS 2062-2011Gr E250		1130		1.40	1582
7	Link pin girder end		IS 2062-2011Gr E250		564		7.00	3948
8	Link pin purlin end		IS 2062-2011Gr E250		564		4.60	2594
			IS 2062-2011Gr E250					0
9	Axle pipe for purlin(48.3OD)5.08TK		ASTM A-53 SCHEDULE 80		564		3.80	2143
10	Locking Pin		IS 2062-2011Gr E250		1700		0.03	54
11	Link pipe purlin end(48.3OD)5.08TK		ASTM A-53 SCHEDULE 80		564		1.14	643
12	Link pipe girder end(48.3OD)5.08TK		ASTM A-53 SCHEDULE 80		564		3.00	1692
13	Connecting Link		IS 2062-2011Gr E250		564		6.98	3935.6
14	Strips for holding girder		IS 2062-2011Gr E250		1180		0.24	283.2
15	Girder Mounting Plate		IS 2062-2011Gr E250		292		29.00	8468.0
								29648.3
SS HARDWARE								
Mark No	Item Description	Profile Shape	Grade	Thickness	Nos. for 1 MW	Length/Area	Unit/Wt	Total wt.
				mm		mm	kg/m OR kg/m²	kgs
16	M6x20 Bolt+Nut+2 plain Washers+1 spring washer		SS304 and Class A2-70		20500		0.02	410.0
								30058.3
Total weight of MMS STRUCTURE								220478.5