

Telangana State Power Generation Corporation Limited
4x270 MW MANUGURU

TECHNICAL SPECIFICATION
FOR
CONTROL VALVES WITH ACCESSORIES
(Pneumatically Operated)

VOLUME II-B & III

SPECIFICATION No: **PE-TS-411-145-I 801**



BHARAT HEAVY ELECTRICALS LIMITED
POWER SECTOR
PROJECT ENGINEERING MANAGEMENT DIVISION
NOIDA, INDIA



PREAMBLE

SPECIFICATION NO. PE-SS-999-100-Q-001

VOLUME

SECTION

REV. NO.

DATE

SHEET

OF

1.0 The tender document contains three (3) volumes. The bidder shall meet the requirements of all the three volumes.

1.1 **Volume-I (CONDITIONS OF CONTRACT)**

This consists of four parts as below :-

- Volume-IA : This part contains instructions to bidders for making bids to BHEL.
- Volume-IB : This part contains general commercial conditions of the tender & includes provision that vendor is responsible for the quality of item supplied by their sub-vendors.
- Volume-IC : This part contains special conditions of contract.
- Volume-ID : This part contains commercial conditions for erection & commissioning site work, as applicable.

1.2 **Volume-II TECHNICAL SPECIFICATIONS**

Technical requirements are stipulated in Volume-II which comprises of :-

- Volume-IIA : General Technical Conditions
- Volume-IIB : Technical Specification including Drawings, if any.

1.2.1 **Volume-IIB**

This volume is sub-divided into following sections :-

- Section-A : This section outlines the scope of enquiry.
- Section-B : This section provides "Project Information".
- Section-C : This section indicates technical requirements specific to the contract, not covered in Section-D.
- Section-D : This section comprises of technical specifications of equipments complete with data sheet A, B and C.

Data Sheet - A specifies data and other requirements pertaining to the Equipment.

Data Sheet - B Specifies data to be filled by the bidder (Data Sheet-B is contained in Volume-III).

Data Sheet - C Indicates data/documents to be furnished after the award of contract as per agreed schedule by the vendor (as applicable).

1.2.2 **Volume-III TECHNICAL SCHEDULES**

This volume contains technical schedules and Data Sheets-B, which are to be duly filled by the bidder and the same shall be furnished with the technical bid as per instructions given in Document No. PE-SS-999-100-Q-002 in Volume-III.

2.0 The requirements mentioned in Section-C / Data Sheets-A of section-D shall prevail and govern in case of conflict between the same and the corresponding requirements mentioned in the descriptive portion in Section-D.

**Telangana State Power Generation Corporation Limited
4x270 MW MANUGURU**

**TECHNICAL SPECIFICATION
FOR
CONTROL VALVES WITH ACCESSORIES
(Pneumatically Operated)**

VOLUME II-B

SPECIFICATION No: PE-TS-411-145-I 801



**BHARAT HEAVY ELECTRICALS LIMITED
POWER SECTOR
PROJECT ENGINEERING MANAGEMENT DIVISION
NOIDA, INDIA**

	Technical specification for Control Valves with Accessories (Pneumatically Operated) 4x270 MW MANUGURU	SPEC NO.: PE-TS-411-145-I 801	
		VOLUME II B	
		SECTION	
		REV. NO. 00	DATE : 22.12.2014
		SHEET	OF

CONTENTS

VOL-II B

SECTION	TITLE
A	Scope of Enquiry
B	Project Information
C	Specific Technical Requirements
	Typical Hook-up Diagram for Control valve
D	Equipment specification
	Data sheets A & B for Control Valves & Accessories
	Data sheets C for Control Valves & Accessories
	Quality Plan for Control Valves
	Bill of Quantity
	Spares
	Schedule of submission of drawings/ documents equipment manufacture, inspection and dispatch.

	<p>Technical specification for Control Valves with Accessories (Pneumatically Operated)</p> <p>4x270 MW MANUGURU</p>	SPEC NO.: PE-TS-411-145-I 801	
		VOLUME II B	
		SECTION	
		REV. NO. 00	DATE : 22.12.2014
		SHEET	OF

CONTENTS

VOL- III

SECTION	TITLE
1.	COMPLIANCE CERTIFICATE
2.	SCHEDULE OF PRICES
3.	SCHEDULE OF UNIT PRICES
4.	CV TEST CHARGES
5.	INSPECTION SCHEDULE



Technical specification for
Control Valves with Accessories
(Pneumatically Operated)

4x270 MW MANUGURU

SPEC NO.: **PE-TS-411-145-I 801**

VOLUME II B

SECTION A

REV. NO. 00

DATE : 22.12.2014

SHEET OF

SECTION – A
SCOPE OF ENQUIRY

	Technical specification for Control Valves with Accessories (Pneumatically Operated) 4X270 MW MANUGURU	SPEC NO.: PE-TS-411-145-I 801		
		VOLUME	II B	
		SECTION	A	
		REV. NO.	00	DATE : 22.12.2014
		SHEET	OF	

SCOPE OF ENQUIRY

1.0 SCOPE

This specification covers the Design, Manufacture, Inspection and Testing at manufacturer's works, proper packing for transportation and delivery to site of the Control Valves with Pneumatic Actuator along with Accessories, Start-up/Commissioning as mentioned in different sections of this specification for **4x270 MW MANUGURU**.

1. The quality plan enclosed forms the minimum requirement but not limited to be adhered to by the bidder.

2. The enquiry shall be operated in "**COMPLIANCE MODE**" means bidder to comply with the requirement of specification, quality plan, delivery schedule, quantities, start-up/commissioning spares, mandatory spares, recommended spares etc, and as a token of acceptance of the same, following formats to be signed, stamped with company seal and submitted for the project.

- a) Compliance certificate
- b) Quality plan
- c) Schedule of price, unit prices, inspection schedule
- d) Schedule of submission of drawings / documents, equipment manufacture inspection and dispatch

3. No separate technical offer, data sheets to be submitted with the bid. Any such document shall not be taken cognizance of, and document (Compliance certificate) at 3 above shall be final and binding. Data sheets shall be furnished by the successful bidder (vendor), only after the award of contract & shall be subject to Purchaser's Approval.

4. Bidder to note that CV test is required to be conducted on one type per size, CV value. Bidder to group such valves and indicates the same along with the price bid. Unpriced portion to be submitted to engineering.

2.0 GENERAL TECHNICAL INSTRUCTIONS

1 It is not the intent here to specify all the details of design and manufacture. However, the equipment shall conform in all respects to high standard of design, engineering and workmanship and shall be capable of performing the required duties in a manner acceptable to the customer / consultant, who will interpret the meaning of drawing and specification and shall be entitled to reject any component or material which in his judgment is not in full accordance herewith.

2 The omission of specific reference to any component / accessory necessary for the proper performance of the equipments shall not relieve the supplier of the responsibility of providing such facilities to complete the supply within the quoted prices.

3 BHEL's / Customer's representatives shall be given access to the shop in which the equipments are being manufactured or tested and all test records shall be made available to them.

4 The Equipment covered under this specification shall not be dispatched unless the same have been finally inspected, accepted and Material Dispatch Clearance Certificate (MDCC) is issued by BHEL / CUSTOMER.



Technical specification for
Control Valves with Accessories
(Pneumatically Operated)

4X270 MW MANUGURU

SPEC NO.: **PE-TS-411-145-I 801**

VOLUME II B

SECTION B

REV. NO. 00

DATE : 22.12.2014

SHEET OF

SECTION – B

PROJECT INFORMATION

PROJECT INFORMATION 4X270 MW MANUGURU TPS

INTRODUCTION

4x270 MW Manuguru TPS is being set up by Telangana State Electricity Corporation Limited (TSGENCO) at Manuguru in the district of Khammam, Telangana, India.

The Bidder shall acquaint himself by a visit to the site, if felt necessary, with the conditions prevailing at site before submission of the bid. The information given here in under is for general guidance and shall not be contractually binding on BHEL/Owner. All relevant site data /information as may be necessary shall have to be obtained /collected by the Bidder.

APPROACH TO SITE

The distance from Manuguru to Major cities in state: Hyderabad-345KM, Warangal-180km, Bhadrachalam-38km, Kothagudem-70km and Khammam-130km, Vijayawada-195km.

District: KHAMMAM

State: TELANGANA

Nearest Airport: The nearest airport is Vijayawada Airport but the most used airport is the Hyderabad International Airport.

Nearest Railway Station: Manuguru railway station is 10KM from nearby town. However Warangal/Vijaywada railway Station is major railway station near to Manuguru.

PROJECT INFORMATION 4X270 MW MANUGURU TPS

1. **Owner** TSGENCO
2. **Owner Consultant** DESEIN PRIVATE LIMITED, NEW DELHI

3. **Project Title** 4X270 MW MANUGURU TPS
4. **Location** 16 Km from Manuguru Railway station
5. **Nearest Railway Stn.** Manuguru
6. **Temperature**
 - a. Mean daily minimum ambient temperature during oldest month of the year=11.5 Deg.C
 - b. Mean daily minimum ambient temperature during hottest month of the year=45.1 Deg.C
7. **Rainfall**

Intensity of rainfall @ 80 mm/hr considering heaviest fall in 24 hrs
8. **Wind Data**
 - a. Basic wind speed at 10m height
44 m/sec
 - b. Wind pressure As per IS: 875 Part III- 1987

9. **Seismic Zone** Zone III as defined in IS:1893 (part-1)-2002 according to Indian Standard Seismic Zoning Map

10.0	Power Supply The power supplies for distribution and auxiliaries shall be as under:	
	a) In plant generation	16.5kV $\pm 5\%$, 3ph, 50Hz $\pm 5\%$, high resistance earthed.
	b) MV distribution	6.6kV $\pm 10\%$, 3ph, 3w , 50 Hz, + 5% to - 5%, Medium Resistance grounding
	c) LT distribution	415V $\pm 10\%$, 3ph, 3W, 50Hz + 5% to -5%, High Resistance Grounding for all plant area shall be provided.
	d) Motor rated 160kW and above 160kW	6.6kV $\pm 10\%$, 3 ph, 3W,50Hz +5% to -5%.
	e) Motor rated below 160kW and all motorized actuators.	415V $\pm 10\%$, 3 ph,3w, 50Hz +5% to -5%.
	f) For motors equal and below 30kW winding heating	24V AC $\pm 10\%$, 50 Hz %, [to be generated in 415V switchgear by vendor]

PROJECT INFORMATION 4X270 MW MANUGURU TPS

	g) DC Motors	220V DC + 10% to - 15%, 2 wire ungrounded system
	h) Control supply for relay panel/ 6.6kV breakers/415V breakers and DC emergency lighting.	220V DC + 10% to - 15%, 2 wire ungrounded system
	i) UPS for instrumentation & Control system	240V AC $\pm 1\%$, 1 ph ,50Hz $\pm 0.5\%$ 2 Wire AC system
	j) Control supply for 415V Motor contactors/AC Control circuits [to be generated in MCC /panel by vendor]	110V AC $\pm 10\%$, 50Hz + 5% to -5%.
	k) Diesel Generator emergency supply	415V $\pm 10\%$, 3ph,3W, 50Hz +5%to -5%.
11.0	Fault levels	
	a) 400kV	40kA rms for 1 sec
	b) 6.6kV	40 kA rms for 1 sec.
	c) 415V	50 kA rms for 1 sec.



Technical specification for
Control Valves with Accessories
(Pneumatically Operated)

4X270 MW MANUGURU

SPEC NO.: **PE-TS-411-145-I 801**

VOLUME II B

SECTION C

REV. NO. 00

DATE : 22.12.2014

SHEET OF

SECTION – C

SPECIFIC TECHNICAL REQUIREMENTS

	<p>Technical specification for Control Valves with Accessories (Pneumatically Operated)</p> <p>4X270 MW MANUGURU</p>	SPEC NO.: PE-TS-411-145-I 801		
		VOLUME	II B	
		SECTION	C	
		REV. NO.	00	DATE : 22.12.2014
		SHEET	OF	

CONTENTS

VOL-II B (SECTION-C)

S.NO.	TITLE
1.	Specific Technical Requirements
2.	Hook-up Diagram for Control valve

	Technical specification for Control Valves with Accessories (Pneumatically Operated) 4X270 MW MANUGURU	SPEC NO.: PE-TS-411-145-I 801		
		VOLUME	II B	
		SECTION	C	
		REV. NO.	00	DATE : 22.12.2014
		SHEET	OF	

SPECIFIC TECHNICAL REQUIREMENTS.

The requirements in this section are specific for this project and shall over-ride the specification under section D in case of any contradiction.

1. All the formats in Volume-III, SCHEDULE OF SUBMISSION OF DRG./DOC. and QUALITY PLAN (BHEL Format) should filled-up and furnished with the bid, complete in all respect. In the absence of those, the bid would be considered incomplete and liable for rejection. Catalogue, Leaflets related with the models of Control Valves as well as each Accessory must be furnished with the offer.
2. The Hook-up diagram for Control valve, is attached. The scope demarcation as indicated should be adhered. The connection details at Instrument Air valve shall be furnished to successful bidder after the award of contract.
3. Valve Body Sizes shall be quoted to take care of the specification requirements like parameters, and limitations of Fluid outlet velocities, Noise Level etc. **However Port (Trim) Sizes shall be selected to suit CV requirement for achieving percentage valve lift as per Technical Specification.**
4. Bidder to note that, **wherever downstream side of the valve is subjected to the Vacuum service, bidder to offer double Gland packing, and in that case, flow direction of working fluid shall be to close the valve.** Separate indication for the same has not been made in the data sheets-A.
5. For valves subjected to cavitation service, anti-cavitation trim shall be provided.
6. In case during erection/commissioning of the control valve, any spares are required which have not been specified in the Start-up/commissioning spares list, the same will have to be supplied by the bidder free of cost
7. Facility to adjust the maximum travel of the stem & starting point of travel shall be incorporated.
8. SS nameplate to control valve shall include Tag no./ KKS no./ Sl. No./ Body material/ size/ Press Rating/ Trim material/ Trim type/ action on air failure/ diaphragm air press at full open and close condition
9. Hand wheel shall have open/ close direction.
10. Limit switch shall be designed for 1,00,000 operations.
11. JB shall be 36 ways as per enclosed hook-up diagram.
12. The material of filter for Air Filter Regulator shall be Sintered bronze.
13. Bidder to indicate pick-up & drop out voltage for all solenoid valves.
14. Protection class for Limit switches, I/P converter and Position transmitter shall be IP-65 only.
15. All JBs and valves shall be with double compression type Ni plated brass cable glands.
16. Solenoid valve class of protection shall be IP-65.
17. All local cabling up to JBs shall be in Conduit (Flexible/Rigid). If JB is not mounted near valve
18. Noise Reduction shall be made through inherent design and not through external means.

	Technical specification for Control Valves with Accessories (Pneumatically Operated)		SPEC NO.: PE-TS-411-145-I 801	
	4X270 MW MANUGURU		VOLUME	II B
			SECTION	C
	REV. NO.	00	DATE	: 22.12.2014
	SHEET		OF	

SPARES: The following spares are required to be offered

A. Recommended Spares:

The bidder shall furnish a List of Recommended spares for 3 years of normal operation of the Control valves / Accessories. The BHEL/ Customer reserves the right to buy any or all of the recommended spares.

B. Start-up & Commissioning Spares:

Start-up and Commissioning spares are those spares, which may be required during the start-up and commissioning of the Control Valves. All start-up spares, which are supplied under this contract, shall be strictly interchangeable with the parts for which they are intended for replacements. The format for price schedule to be filled-up by the bidder is enclosed in Volume-III. The Start-up and commissioning spares indicated by the bidder shall be a part of the main Control valves supply. However bidder to indicate prices separately. The list of these spares required is enclosed in the section-D of this specification.

Bidder to indicate the service life expectancy period for the spare parts under normal working conditions. The spares shall be treated and packed for long storage, under climatic conditions prevailing at site. Small items shall be packed in sealed transparent plastic bags with desiccator's packs as necessary.

19. Documentation:

(A) Along with the bids: following documents for the project

- a) Signed and stamped compliance certificates in attached format(VOL.-III).
- b) "Schedule of prices" and "Schedule of unit Prices" in attached format (VOL.-III).
- c) Schedule of submission of Drg. / Doc, Equip. Manufacture, Inspection and Dispatch.
- d) Inspection schedule
- e) Quality Plan Duly signed and Stamped

(B) After the award of contract:

The documentation as listed below for the project

6 sets of the following documents + 3 sets of CDs to be enclosed with the bids for Approval:

- a. Assembly (dimensional) drawings.
- b. Valve Edge preparation details.
- c. Data sheet-C completely filled-up.
- d. Hook-up diagram of Control Valve with Actuator & Accessories.
- e. Valve & Actuator assembly dimensional drawings with weights.
- f. Quality Plan duly signed and stamped.

	Technical specification for Control Valves with Accessories (Pneumatically Operated) 4X270 MW MANUGURU	SPEC NO.: PE-TS-411-145-I 801		
		VOLUME	II B	
		SECTION	C	
		REV. NO.	00	DATE : 22.12.2014
		SHEET	OF	

- g. All calculations like CV, Noise Level, Valve Outlet Velocity, Actuator sizing etc.
- h. All relevant catalogues for the models of the valves as well as accessories finalized.
- i. Bar chart to indicate the time schedule for procurement, manufacture, testing and dispatch.

(B) Final documentation:

The documentation as listed below will separate for respective projects

1. Category -I & IV Approved final drawings/data sheets, - 20 sets with 4 CD-ROMS
Valve sizing calculations, Noise level calculations and
Valve Outlet Velocity calculations.
2. Test certificates - 20 sets.
3. Operation & Maintenance Manuals - 20 sets with 4 CD-ROMS
for Control Valve, Actuator and all the Accesories

NOTES : 1. Packing instructions :- Packing boxes shall have clear marking "To be stored indoor, away from water and dust."



**SPECIFICATION FOR MICROPROCESSOR BASED
ELECTRONIC POSITIONER (SMART)**

SPECIFICATION NO.: PES – 145 – 06A

VOLUME

SECTION

REV. NO.

01

DATE : 30.09.2009

SHEET

1

OF

3

1.0 Electrical :

Input Signal	4-20mA
Power Supply	Loop Powered from the output card of Control System (12-30 V DC)
Hart Protocol	Compatibility for Remote Calibration & Diagnostic (Super-Imposed HART Signal on Input Signal to positioner (4-20mA)
Valve Position Feedback	4-20mA output signal for Position Feedback is to be provided to control system.

2.0 Environment :

Operating Temperature	(-) 30 To 80 Deg.C
Humidity	0-95%
Protection Class	IP-65 (Minimum)

3.0 Diagnostic Features :

Diagnostic / Test Features (to be available in Smart Positioner and shall be accessible through any HMS software)	Minimum Diagnostic Features Like <ul style="list-style-type: none"> • Measurement of Valve positioning timing, • Detection of actuator leakage, • Display of fault alarm. • Logging of alarms and history. • Valve friction/jamming detection. • Detection of valve wear & tear, • Valve stroke length and timing.
	Advanced Diagnostic Features Like (OPTIONAL, if specified in customer's specification) <ul style="list-style-type: none"> • On line partial closure test. • Valve signature analysis (online graphical/tabular representation of input signal Vs valve travel). • Step response test.

4.0 Software :

Software (to be supplied alongwith smart positioner)	<ul style="list-style-type: none"> • Windows based software to meet the requirement for configuration, diagnostics, calibration and testing of Valve and actuator. • Easily up-gradable with same hardware and compatible with any Hart Management Systems (HMS). • Shall be capable to cater to all the tags in the specification at the same time.
--	---



**SPECIFICATION FOR MICROPROCESSOR BASED
ELECTRONIC POSITIONER (SMART)**

SPECIFICATION NO.: PES – 145 – 06A

VOLUME

SECTION

REV. NO.

01

DATE : 30.09.2009

SHEET

2

OF

3

5.0 Hardware :

Hardware (As required)	1. PC with software for configuring and accessing diagnostic features of the positioners.
	2. Multiplexers for interfacing smart positioner with PC.
	3. Communication cable for interconnecting multiplexers with PC.
	4. RS232/RS485 converter (if required)

Note : Power supply for Multiplexer shall be arranged by the owner.

6.0 Valve Action :

Valve Action	Direct & Reverse. (Same positioner for Single Acting or Double Acting And no separate relays required for changing from Single acting to double).
	During Failure of input Electrical signal (4-20 mA), valve to attain fail Freeze position without any external hardware. (Sol valve, Power Supply etc.)

7.0 Flow Characterization :

Flow Characterization	Possible to fit valve characteristic curve linear & Equal percentage
------------------------------	--

8.0 Performance:

Characteristic Deviation	<=0.75% of span
Ambient temp effect	<=0.01% /Deg C or better.
Dead Band	Adjustable 0.1 to 10%.
Scan Time	10ms
Resolution	<=0.05%
Sensitivity/Linearity	0.3-0.4% of FS
Repeatability	0.32% of FS

9.0 Test Certificates:

Test Certificates/Test Reports for degree of protection, Accuracy and calibration test (as a minimum) to be submitted as per Manufacture Standard / Relevant Standard.

10.0 EMC & CE compliance

International Standard Like EN/IEC.

To EN 50081-2 & EN 50082 or equivalent



**SPECIFICATION FOR MICROPROCESSOR BASED
ELECTRONIC POSITIONER (SMART)**

SPECIFICATION NO.: PES – 145 – 06A

VOLUME

SECTION

REV. NO.

01

DATE : 30.09.2009

SHEET

3

OF

3

11.0 Accessories

In Built Operator Panel	Display with push buttons for Configuration and display on the positioner itself
Hand Held Hart Calibrator (Optional)	Universal Hart Calibrator To Be Provided, One Per Unit.
Press Gauge Block	For Supply & Output Pr., Filter Regulator Other Accessories Shall Be Provided As per Control valve hook-up diagram.
Electrical cable entry	½ - NPT, side or bottom entry to avoid water Ingress.



Technical specification for
Control Valves with Accessories
(Pneumatically Operated)

4x270 MW MANAGURU

SPEC NO.: PE-TS-411-145-I 801

VOLUME II B

SECTION D

REV. NO. 00

DATE : 22.12.2014

SHEET OF

SECTION-D

**EQUIPMENT SPECIFICATION
DATA SHEETS - A&B
DATA SHEETS - C
QUALITY PLAN
BILL OF QUANTITY
SPARES**



Technical specification for
Control Valves with Accessories
(Pneumatically Operated)
4X270 MW MANUGURU

SPEC NO.: **PE-TS-411-145-I 801**

VOLUME II B

SECTION D

REV. NO. 00

DATE : 22.12.2014

SHEET OF

SECTION – D
EQUIPMENT SPECIFICATION



**SPECIFICATION FOR CONTROL VALVE
(WITH PNEUMATIC / ELECTRIC ACTUATOR)**

SPECIFICATION NO.: PES – 145 - 06

VOLUME II B

SECTION D

REV. NO. 05

DATE : 15-05-2007

SHEET 1 OF 13

1.0 SCOPE

This specification covers the Design, Manufacture, Inspection and Testing at the manufacturer's works, proper packing for transportation and delivery to site of Control valve (with Pneumatic/Electric Actuator) for use in Utility/Captive Power Station/Combined Cycle Station.

2.0 CODES AND STANDARDS

2.1 All the equipments specified herein shall comply with the requirements of the latest issue of the relevant National and International standards.

2.2 The Design and Materials used for the components shall also comply with the relevant National and International standards.

2.3 As a minimum requirement, the following standards shall be complied with :

Indian Boiler Regulation (IBR)	:	
Allowable Seat leakage	:	ANSI-B16.104 / FCI-70.2
Pressure & Temperature ratings	:	ANSI-B16.34
Enclosure class	:	IEC-144 / NEMA / IS-13947
Control Valves	:	ISA S-75
Electric Motor operated Actuators	:	IS-9334

3.0 TECHNICAL REQUIREMENTS

The Control valve, Actuator and the accessories shall be suitable for continuous operation under an ambient temperature of 0-55°C and Relative Humidity of 0-95% unless specified otherwise in volume IIB Section-B or Section-C.

3.1 Control Valve

The control valve shall be suitably designed for the operating conditions and system characteristics as specified in the Data Sheet-A.

3.1.1 The control valve shall be of globe body design with single port. The valve trim, shall be suitable for quick removal without any cutting or welding.

3.1.2 The material of body, internals and packing shall be as specified in the data sheets. Alternatives, considered more suitable for service specified may be given as alternative offer, along with adequate justification. However main offer shall totally meet specification requirements. Asbestos shall not be used for the packing or any other component.

3.1.3 The valve bonnet and packing shall be suitable for the service conditions as in Data Sheet-A. Gland sealed type bonnets are not acceptable. Double packing is mandatory for applications involving vacuum service. Bonnets having teflon packing shall have valve stem finished to 2-4 microns. Packing material requiring lubrication will not be acceptable. Justification for proper selection of bonnet & packing shall be furnished in the bid.

3.1.4 The valve end connection as specified in Data Sheet-A shall conform to ANSI B16.25 for Butt Weld connection and ANSI B16.5 for flanged ends. End to end dimension shall be as per ANSI 16.10.

3.1.5 The valve seat leakage shall be as per ANSI B16.104 / FCI-70.2. The leakage class shall be as per Data Sheet-A.



**SPECIFICATION FOR CONTROL VALVE
(WITH PNEUMATIC / ELECTRIC ACTUATOR)**

SPECIFICATION NO.: PES – 145 - 06

VOLUME II B

SECTION D

REV. NO. 05

DATE : 15-05-2007

SHEET 2 OF 13

- 3.1.6 The valve body shall have the direction of flow embossed on all valves.
- 3.1.7 The sizing shall conform to the requirements of ANSI/ISA(S75- 01), and the valve capacity shall be selected so as to meet the following:
- | | | | | |
|--|---|---|---|--------------------|
| Valve with Linear characteristic. | - | Normal Flow (Design Point) | : | 70-75% valve lift. |
| | - | Max. Flow | : | 90% valve lift. |
| | - | Min. Flow | : | >10% valve lift. |
| Valve with Equipercentage Characteristic | - | Normal Flow (Design Point) | : | 75-85% valve lift. |
| | - | Max. Flow | : | 90% valve lift. |
| | - | Min. Flow | : | >10% valve lift. |
| ON/OFF Quick open Characteristic | - | 1.1 times the CV calculated on the basis of maximum flow condition. | | |
- 3.1.8 Calculation for valve sizing, velocity and noise shall be subject to purchaser's approval during contract stage. However responsibility of proper selection and design for the duties specified lies with the vendor. Any modifications required to be done on the valves or actuators & accessories to achieve satisfactory performance of the control system shall be done without any commercial implication.
- 3.1.9 Suitable justification and evidence shall be furnished regarding proper selection of the valve.
- 3.1.10 The valve outlet velocities shall be limited to the following values, unless otherwise specified in the Data sheet-A.
- | | | | |
|-----|----------------|----|--|
| i) | Liquid service | <= | 7 Metres/Sec. |
| ii) | Steam service | <= | 1/3 Sonic velocity in the flow medium. |
- 3.1.11 For flashing duty, the trim design shall be such that the vapour bubbles are kept away from valve body.
- 3.1.12 For cavitation service, the trim design shall be of multistage pressure drop type, so as to avoid cavitation altogether, instead of keeping cavitation away from valve parts.
- 3.1.13 In case of predicted noise level above 85 dBA, suitable low noise trim or inbuilt diffusers shall be provided to bring down the noise level below 85dBA.
- 3.1.14 The equivalent weighted sound level measured at 1.5M. above floor level in elevation and one metre horizontally from the control valve expressed in decibels to a reference of 0.0002 microbar shall not exceed 85 dBA (without pipe insulation). The offer shall include noise prediction calculations for each valve.
- 3.1.15 In case of wrong selection/mal operation of valve and for associated actuator during guarantee period, the vendor shall replace the valve suitably with a modified/new valve of design as approved by purchaser and all the expenses for replacement, rectification/modification including transportation both ways will be at vendor's expenses.



**SPECIFICATION FOR CONTROL VALVE
(WITH PNEUMATIC / ELECTRIC ACTUATOR)**

SPECIFICATION NO.: PES – 145 - 06

VOLUME II B

SECTION D

REV. NO. 05

DATE : 15-05-2007

SHEET 3 OF 13

3.2 Pneumatic Actuator

The pneumatic actuators shall be employed for modulating or open/close duty, as specified in Data Sheet-A. The bidder shall be responsible for proper selection and sizing of valve actuators in accordance with the pressure drops and shut off pressure.

3.2.1 The pneumatic spring opposed diaphragm actuator for modulating duty shall be capable of positioning the associated valve at desired opening for all the operating conditions specified.

3.2.2 The pneumatic actuator for open/close duty shall be suitable for fast opening/closing of the associated valve.

3.2.3 The actuator design shall allow valve assembly to be mounted at 45° inclination on either side in the vertical plane.

3.2.4 The actuators shall be suitably sized to ensure that the associated valve travel time from full open to full closed position and vice versa is less than 20 seconds under the most stringent service conditions.

3.2.5 The actuator shall be painted with epoxy based paint.

3.3 Accessories for Control valve with Pneumatic Actuator

The bidder shall offer all the accessories as specified in the Data Sheet - A for the Pneumatic Actuators under modulating or OPEN/CLOSE duty. The accessories specified shall be supplied duly mounted on the valve actuator and piped with PVC covered copper tube and flareless brass fittings (Refer typical hook up diagram in sheet 12 of 12).

3.3.1 Handwheel

Handwheel shall have OPEN & CLOSE direction marking and clockwise rotation as viewed from front shall close the valve. The handwheel shall have a circular stainless steel plate with Tag number and service.

3.3.2 Local Position Indicator

Each actuator shall be provided with a mechanical pointer attached to stem, moving over a graduated scale with markings, for OPEN, 25%, 50%, 75%, CLOSE positions.

3.3.3 Position Transmitter

The position transmitter shall be supplied as indicated in Data Sheet-A. The electronic position transmitter shall be non-contact type with 4-20 mA DC 2-wire output suitable for 12-50V DC supply. The resistance type position transmitter shall have 0-100 ohm variation for valve position change of 0-100%. The position transmitters of both types shall have accuracy and enclosure class. Necessary cable glands shall be supplied.



**SPECIFICATION FOR CONTROL VALVE
(WITH PNEUMATIC / ELECTRIC ACTUATOR)**

SPECIFICATION NO.: PES – 145 - 06

VOLUME II B

SECTION D

REV. NO. 05

DATE : 15-05-2007

SHEET 4 OF 1

3.3.4 Air Filter Regulator

Instrument quality air at suitable pressure of 5.5 Kg/Cm²(g) to 7 Kg/Cm²(g) shall be supplied to each valve through air filter regulator. The filter regulator shall include an inbuilt blow-down valve, 5 micron size filter. The design pressure for regulator shall be 7 Kg/cm²g. The Air filter regulator shall be selected to meet the requirements of positioner/actuator, E/P convertor and air-lock. The flow capacity of the Air filter regulator shall be variable with a knob. Output gauge shall be provided wherever pneumatic positioner is not specified for the valve.

3.3.5 Air Lock Relay

Air lock relay shall retain the valve position stayput, in case of air supply failure and shall reset automatically on resumption of air supply. Air lock shall have a threaded plug for evacuating diaphragm air if required for local manual operation.

3.3.6 Solenoid Valves

Solenoid valves are meant for interlock & protection purposes overriding the controller signal, and/or to result stayput action on controller signal failure. The Solenoid valve shall be 3-way **Universal** type and the valve internals shall be of stainless steel. The coil shall have class-H insulation and rated for continuous AC/DC duty as specified in Data sheet-A. The enclosure shall be to IP-55. Cable gland shall be provided for cable entry. The solenoid shall in general conform to IS-8935. The solenoid operation shall be universal type. The solenoid shall be suitable for 24V DC supply, unless specified otherwise in Data Sheet-A.

3.3.7 Limit Switches

Limit switches are required as specified in the data sheet-A. Each limit switch shall have 2NO+2NC contacts with contact rating of 5A at 240V AC/0.2A at 220V DC unless otherwise specified. The switch enclosure shall conform to IP-55. Each limit switch shall be supplied with cable glands.

3.3.8 I/P Converter

I/P Converters shall preferably be of force balance type and shall produce pneumatic output signal corresponding to input current signal, also specified in Data Sheet. Convertor electronics shall be protected against reverse connection of signal polarities and a separate external connection shall be provided to facilitate grounding of instrument casing. Cable glands with neoprene gromets suitable for PVC cables shall be provided. I/P convertor shall have span adjustment facility. I/P convertor enclosure shall conform to IP-55 enclosure class.

3.3.9 Positioner

Positioner shall be suitable for accepting controller output signal 0.2-1.0 Kg/cm², 0.2-0.6 Kg/cm² or 0.6-1.0 Kg/cm² as specified and give an output suitable for the actuator. Pneumatic positioner shall have 3 gauges. All gauges shall have metric scales. The positioner input signal range shall be adjustable. Wherever applicable, it shall be possible to bypass the positioner by means of a switch. **Linearity and Hysteresis shall be as indicated in Data sheet-A**

3.3.10 Electro pneumatic Positioner

In place of separate E/P Converter and pneumatic positioner a combined electro pneumatic positioner can also be supplied. The electro pneumatic positioner shall have 2 gauges.



**SPECIFICATION FOR CONTROL VALVE
(WITH PNEUMATIC / ELECTRIC ACTUATOR)**

SPECIFICATION NO.: PES – 145 - 06

VOLUME II B

SECTION D

REV. NO. 05

DATE : 15-05-2007

SHEET 5 OF 13

3.3.11 Junction Box

Wherever specified, an integral junction box with all electrical accessories conduited up to JB shall be supplied. The junction box shall have two (2) cable glands for outgoing cables. Junction box shall have enclosure class of IP-55.

3.4 Guarantee & Performance

3.4.1 The overall performance of the control valve with pneumatic actuator assembly shall be as follows:-

i)	Hysteresis	:	$\pm 1\%$ of span
ii)	Linearity	:	$\pm 2\%$ of span
iii)	Sensitivity	:	$\pm 0.5\%$ of span.
iv)	Repeatability	:	$\pm 1\%$ of span
v)	Accuracy (Overall)	:	$\pm 2\%$ of span

3.4.2 The guarantee for the control valve, pneumatic actuator & accessories shall be for 12 months continuous operation from the date of commissioning, unless specified otherwise in VOL-IIB Section-B or Section-C.

3.5 Electric Actuator

The electric actuator shall be employed for modulating duty.

3.5.1 The actuator assembly shall be complete with drive motors, gears, hand wheel, signaling & switching units, associated control, integral starter, (when specified) and other accessories as required.

3.5.2 The Electric Actuator shall be capable of positioning the associated valve at the desired opening for all the operating conditions.

3.5.3 The motor shall meet the requirements of Current, torque, Axial thrust, Accelerating & stall time as imposed by the driven equipment.

3.5.4 The motor shall be suitable for direct on line starting.

3.5.5 Motors shall be suitable for inching & plugging duty operations.

3.5.6 The motors shall be capable of starting and accelerating to rated speed at 85% of rated voltage.

3.5.7 The motors shall be rated for continuous operations for modulating duty.

3.5.8 The motor shall operate satisfactorily under the following conditions:

- i) $\pm 10\%$ supply voltage variation at rated frequency.
- ii) -5% to $+ 3\%$ variation in frequency at rated supply voltage.

iii) Simultaneous variation in voltage and frequency, the sum of absolute percentage not exceeding 10%.

3.5.9 The Actuator shall be suitable for mounting directly on the valve and shall be suitable for mounting in any position. Supports required for inclined mounting shall form part of supply of valve assembly.

3.5.10 The actuator shall be capable of producing the required torque and thrust at the output shaft for satisfactory operation of the associated valve.



**SPECIFICATION FOR CONTROL VALVE
(WITH PNEUMATIC / ELECTRIC ACTUATOR)**

SPECIFICATION NO.: PES – 145 - 06	
VOLUME	II B
SECTION	D
REV. NO.	05
DATE :	15-05-2007
SHEET	6 OF 13

- 3.5.11 Each actuator shall have a hand wheel for emergency operation. The hand wheel shall be designed such that it is declutched automatically when the power supply to the motor is restarted.
- 3.5.12 The hand wheel shall be so arranged that when looking from hand wheel, the valve is closed by rotating the hand wheel in clockwise direction.
- 3.5.13 Motor shall be totally enclosed conforming to IP-65 or better as per data sheet. The enclosure shall be suitable to protect the motor from leakage steam, water or oil from valve joints and glands.
- 3.5.14 Where flameproof enclosures are specified, it shall meet the specification IS-2148.
- 3.5.15 Insulation shall be at least class-B or better and shall be tropicalised to withstand the atmospheric condition.
- 3.5.16 The actuator shall be provided with antifriction bearing in grease filled cartridge.
- 3.5.17 Each actuator shall be provided with a mechanical position indicator to indicate accurately the valve position.
- 3.5.18 The integral starter, if specified in data sheet-A, shall be provided in weatherproof enclosure with protection class not less than IP-65 or better as per data sheet.

The integral starter shall consist of:

- i) Mechanical & Electrically interlocked reversing contractors suitable for class AC4 duty or Thyristor as per data sheet.
- ii) Thermal overload relay.
- iii) Step down control transformer with fuses.
- iv) Interposing relay.
- v) Monitoring relay..
- vi) Open, Close & Stop push buttons.
- vii) Indicating lamps.
- viii) Local-Remote lockable selector switch with spare potential free contacts, wired for remote interface.
- ix) A potential free contact shall be provided for remote annunciation of power failure/overload condition. The contact shall be SPDT, rated for at 5A 240V AC or 0.2A at 220V DC.



**SPECIFICATION FOR CONTROL VALVE
(WITH PNEUMATIC / ELECTRIC ACTUATOR)**

SPECIFICATION NO.: PES – 145 - 06

VOLUME II B

SECTION D

REV. NO. 05

DATE : 15-05-2007

SHEET 7 OF 13

- 3.5.19 The actuator shall be suitably time rated for the duty cycle involved with the necessary number of starts per hour, but in no case, less than 1200 starts per hour.
- 3.5.20 The actuator shall be provided with a suitable control unit for receiving 4-20 mA signal from remote controller.
- 3.5.21 The servomotor gear should have self locking or suitable brake so as to maintain it's last position as and when the motor power is switched off.
- 3.5.22 Thermostat/Thermistor as specified in the data sheet shall be provided for sensing the winding temperature and giving trip command. The trip contact shall be change over type. The contact shall be wired up to the actuator terminal box.
- 3.6 Accessories for Control Valve with Electric Actuator
- 3.6.1 Torque Switches
- i) Each actuator shall be provided with at least one open and one close torque switches each with 2 NO+2 NC contacts. The contacts shall be rated for 5A at 240V AC or 0.2A at 220V DC.
 - ii) The torque switches shall have a minimum accuracy $\pm 3\%$ of set value.
 - iii) The torque switches shall be provided with calibrated knobs for setting desired torque. Separate knobs shall be provided for close and open torque switches.
 - iv) The torque switches shall be provided with mechanical latching device to prevent operation when unsealing from the positions. The latching device shall unlatch as soon as the valve leaves the end position. If such provision is not possible, the torque switches shall be bypassed by end position limit switches, which open on valve leaving end position. These limit switches are additional to the number of limit switches specified elsewhere.
 - v) The torque switches or worm gear shall be self-locking type so that when torque switch operates it remains operated until the actuator is operated in the reverse.
 - vi) The torque switch enclosure shall conform to IP-55.
- 3.6.2 Limit Switches
- Each limit switch shall have 2NO+2NC contact with contacts rated for 5A 240V AC/0.2A 220V DC unless otherwise specified. The switch enclosure shall conform to IP-55. Each limit switch shall be supplied with cable glands.
- 3.6.3 Space Heater
- A space heater shall be provided in limit switch and starter compartments to prevent condensation. This shall be suitable for the power supply specified in the data sheet. Where integral starters are provided the space heaters shall be wired to control supply within the actuator.



**SPECIFICATION FOR CONTROL VALVE
(WITH PNEUMATIC / ELECTRIC ACTUATOR)**

SPECIFICATION NO.: PES – 145 - 06

VOLUME II B

SECTION D

REV. NO. 05

DATE : 15-05-2007

SHEET 8 OF 13

3.6.4 Remote Position Transmitter

The position transmitter shall be supplied as indicated in Data Sheet-A. The electronic position transmitter shall be non-contact type with 4-20mA DC 2-wire output suitable for 12-50V DC supply. The resistance type position transmitter shall have 0- 100 ohm variation for valve position change of 0-100%. The position transmitters of both types shall have $\pm 1\%$ accuracy. The enclosure shall conform to IP-55. Necessary cable glands shall be supplied.

3.6.5 Wiring

- i) The actuator and the accessories will be neatly wired up to the terminal boxes.
- ii) The internal wiring shall be minimum of 1 mm² stranded PVC insulated copper conductor.
- iii) The wiring shall be identified by means of numbered ferrules on both ends of all wires.

3.7 Terminal and Terminal boxes

3.7.1 Motor Terminal Box

- i) The terminals, terminal boards, terminal boxes, winding tails and associated equipment shall be suitable for connection to supply system having short circuit capacity specified in data sheet and clearance time determined by the associated fuses.
- ii) The terminals shall be stud type insulated from the frame. The insulation shall not be porcelain. The studs shall be of brass or stainless steel or phosphor bronze of adequate size.
- iii) The terminal box shall be totally enclosed conforming to degree of protection IP-65.

3.7.2 Actuator Terminal Box

- i) All terminals of limit and torque switches, space heater, position transmitters, thermostat/thermister shall be brought to a common terminal box. The enclosure shall be to degree of protection IP-65.
- ii) Terminal board with plug in connector shall be provided. Alternatively stud type or insertion type may be considered. Pinch screw type however will not be accepted. All terminals shall be shrouded to prevent accidental contact. Where stud type terminals are offered, it shall be as per clause 3.7.1 (ii).
- iii) There shall be at least five terminals spare to terminate spare cores of cable.

3.7.3 Cable Glands

The motor terminal box and actuator terminal box shall be provided with required number of double compression nickel plated brass cable glands to suit cable type and associated size.

3.7.4 Earthing Terminal

Two earthing terminal shall be provided on either side of motor and actuator terminal box.

3.7.5 Painting

The Actuator shall be painted with epoxy-based paint.



**SPECIFICATION FOR CONTROL VALVE
(WITH PNEUMATIC / ELECTRIC ACTUATOR)**

SPECIFICATION NO.: PES – 145 - 06

VOLUME II B

SECTION D

REV. NO. 05

DATE : 15-05-2007

SHEET 9 OF 13

4.0 TESTING AND INSPECTION

4.1 The bidder shall adopt suitable quality assurance plan to ensure that the equipments offered will meet the specification requirements in full.

4.2 The bidder shall furnish the Quality Plan in the format enclosed in volume-III. In case the Quality Plan(s) is/are included in volume-IIB, the bidder shall furnish his Quality Plan strictly in line with the same. The Quality Plan shall be discussed and finalised with the technically accepted bidders before opening the price bid. The stages where purchaser would like to be associated for witnessing or verification of tests would be indicated by the purchaser in the Quality Plan before approval.

4.3 The following test shall be conducted as a minimum requirement.

4.3.1 Control Valve

- i) Radiographic tests on castings.
- ii) Dye penetrant tests on machined surface.
- iii) Ultrasonic tests for the forgings & bars of all valves with 60 Kg/cm² & higher ratings.
- iv) Hydrostatic tests as per ANSI B 16.34 prior to seat leakage tests.
- v) Valve closure and seat leakage tests as per ANSI B 16.104 / FCI-70.2.

4.3.2 Pneumatic Actuators

Functional test of actuator and each accessory.

4.3.3 Electric Actuator

- i) Routine tests on motors as per IS: 325.
- ii) Functional test on actuator and each accessory.
- iii) Insulation resistance and high voltage test.
- iv) Stall current & Stall torque test.
- v) Output shaft speed and torque of actuator and corresponding current tests.

4.3.4 Control valve with Actuator & Accessories fully assembled

- i) Functional tests of control valve operation along with actuator & accessories.
- ii) Dimension checks.

4.3.5 Type tests or Test Reports

- i) Valve lift vs. Flow test (**Cv Test**)
- ii) Degree of protection tests for the enclosures
- ii) Temperature rise test (**applicable for Electrical Actuator only**).
- iii) Type test for motor as per IS: 325.

4.4 Inspection will be conducted by BHEL and/or their authorised representatives as per the agreed inspection schedule. The inspection schedule will be submitted by the bidder, for BHEL's approval at contract stage. The cost of all tests and inspections will be deemed to have been included in the bid. For all the type tests covered under 4.3.5 above, "Type Test Certificates" as per agreed Quality Plan shall be furnished. In the absence of the same, such Type Tests shall be arranged at the Vendor's works in the presence of BHEL and/or their authorised representatives or in independent Test House/Laboratory approved by BHEL.

4.5 **The Standard QP is included in this specification to enable bidder to understand the extent of inspection and testing requirements to execute this job. The successful bidder has to follow the agreed QP, taking care of customer requirements mentioned in Sec-C and submit QP for final approval by BHEL / Customer.**



**SPECIFICATION FOR CONTROL VALVE
(WITH PNEUMATIC / ELECTRIC ACTUATOR)**

SPECIFICATION NO.: PES – 145 - 06

VOLUME II B

SECTION D

REV. NO. 05

DATE : 15-05-2007

SHEET 10 OF 13

5.0 SPARES AND CONSUMABLES

5.1 Commissioning Spares and consumables

As part of the main equipment supply, the bidder shall supply all commissioning spares and consumables required during Start-up,

5.2 Mandatory Spares

The bidder shall offer along with main offer, the Mandatory Spares as specified in Volume IIB Section-C of the specification. The Mandatory Spares offered shall be of the same make and type as the main equipment.

5.3 Recommended Spares

The bidder shall furnish a list of Recommended Spares along with the normal service expectancy period and frequency of replacement; quantities recommended for 3 years operation along with unit rate against each item to enable BHEL / BHEL's Customer to place a separate order later, if required.

5.4 Special Tools & Tackles

The bidder shall furnish a list of Special Tools & Tackles included in the bid.

6.0 DRAWINGS AND DOCUMENTS

6.1 The bidder shall furnish the following documents in required number of copies along with the bid:

6.1.1 Data sheet-B, completely filled-up along with all enclosures.

6.1.2 Wiring diagrams for Electrical Actuators.

6.1.3 Hook up diagrams of Control Valve with Actuator & accessories.

6.1.4 Valve & actuator assembly dimensional drawings with weights.

6.1.5 Quality Plan

6.1.6 All relevant Catalogs with detailed technical information.

6.1.7 Bar-chart to indicate the time schedule for procurement, manufacture, testing and despatch.

6.2 The successful bidder shall furnish the following documents in required number of copies to BHEL during the contract stage:

6.2.1 For approval

i) Dimensional drawings.

ii) Installation drawings with overall dimensions of the completed equipment and clearances for operation and maintenance.

iii) Data sheet-C, completely filled-up along with all the enclosures including the sizing calculations & noise calculations.

iv) Quality Plan.

v) Test Certificates.



**SPECIFICATION FOR CONTROL VALVE
(WITH PNEUMATIC / ELECTRIC ACTUATOR)**

SPECIFICATION NO.: PES – 145 - 06

VOLUME II B

SECTION D

REV. NO. 05

DATE : 15-05-2007

SHEET 11 OF 13

6.2.2 Final / As-built Drawings

Final / As-built drawings / CDs in required number of copies shall be submitted.

6.3 Operation & Maintenance Manuals

O&M Manuals in required number of copies shall be submitted. O&M manuals shall also contain storage and commissioning instructions.

7.0 MARKING AND PACKING

7.1 Marking

A stainless steel metal nameplate should be permanently fixed on each equipment giving its tag number and technical specifications.

7.2 Packing

All equipment / materials shall be suitably packed and protected for the entire period of dispatch, storage and erection against impact, abrasion, corrosion, incidental damage due to vermin, sunlight, high temperature, rain, moisture, humidity, dust, sea water spray (where applicable) as well as rough handling and delays in transit and storage in open.

55

8.0 APPLICABLE DATA SHEET FORMS

This document shall be read with one or more of the following data sheet forms :

- Data sheet A&B for Control Valve with Pneumatic Actuator
- Data sheet C for Control Valve with Pneumatic Actuator
- Data sheet A&B for Control Valve with Electric Actuator
- Data sheet C for Control Valve with Electric Actuator



Technical specification for
Control Valves with Accessories
(Pneumatically Operated)

4X270 MW MANUGURU

SPEC NO.: **PE-TS-411-145-I 801**

VOLUME II B

SECTION D

REV. NO. 00

DATE : 22.12.2014

SHEET OF

SECTION – D

DATA SHEETS – A & B

BHEL PEM	DOCUMENT TITLE	DOCUMENT NUMBER
	DATA SHEET FOR CONTROL VALVES	REVISION 00 NUMBER
	TSGENCO - 4x270 MW MANUGURU	SHEET

Notes: This shall be read in conjunction with section C

1. All general technical requirements including material & construction, leakage class, body sizing and CV sizing etc. shall be as per specifications.
2. Type of bonnet shall be according to the service condition. Extension bonnets shall be provided when the maximum temperature of the flowing fluid is greater than 200 °C.
3. If the downstream is subjected to vacuum, flow direction of the fluid shall be to close. Separate indication for the same has not been made in the data sheet.
4. Valve and actuator shall be designed for full differential pressure (Max. shut-off pressure).
5. Testing & other requirements shall be as per specifications.
6. Quantity indicated is for one unit.
7. Tolerances on end to end, center to center, center to face shall be in accordance with ASME B16.10.
8. In addition to tag nos. DR-22, DM-15 & DM-20, anti cavitation trim to be provided for valves subjected to cavitation as per service conditions.

BHEL PEM	DOCUMENT TITLE	DOCUMENT NUMBER
	DATA SHEET FOR CONTROL VALVES	REVISION 00 NUMBER
	TSGENCO - 4x270 MW MANUGURU	SHEET

INDEX

S.No.	SERVICE	Qty./Unit	Qty. for Four Units
1.	AS-2 DEAERATOR PEGGING FROM AS HEADER	1	4
2.	CD-14 DEAERATOR LEVEL CONTROL	1	4
3.	CD-21 EXCESS RETURN TO CST	1	4
4.	CD-25 CEP MINIMUM RECIRCULATION	1	4
5.	CD-76 CONDENSATE FOR VALVE GLAND SEALING	1	4
6.	CRH-2 DEAERATOR PEGGING FROM CRH	1	4
7.	DR-2 HPH-6 NORMAL DRAIN TO HPH-5	1	4
8.	DR-9 HPH-6 ALT DRAIN TO HP FLASH TANK	1	4
9.	DR-13 HPH-5 DRAIN TO DEAERATOR	1	4
10.	DR-16 HPH-5 ALT DRAIN TO HP FLASH TANK	1	4
11.	DR-19 LPH-3 NORMAL DRAIN TO LPH-2	1	4
12.	DR-22 LPH-3 ALT DRAIN TO LP FLASH TANK	1	4
13.	DR-25 LPH-2 NORMAL DRAIN TO LPH-1	1	4
14.	DR-28 LPH-2 ALT DRAIN TO LP FLASH TANK	1	4
15.	DR-38 DEAERATOR OVERFLOW TO LP F/TANK	1	4
16.	FD-14 FEED CONTROL VALVE(100% CAPACITY)	1	4
17.	FD-17 FEED CONTROL VALVE(100% CAPACITY)	1	4
18.	FD-20 FEED CONTROL VALVE (30% CAPACITY)	1	4
19.	DM-15 EMERGENCY MUP TO CONDENSER	1	4
20.	DM-20 NORMAL MUP TO CONDENSER	1	4



**4X270 MW MANUGURU TPS
DATA SHEET FOR CONTROL VALVES
(WITH PNEUMATIC ACTUATOR)**

SPECIFICATION NO.: PE-TS-411-145-1104A	
VOLUME	
SECTION	
REV. NO. 1	DATE : 13.02.15
SHEET	

Tag No.: **CD-14/LCA40AA101** Qty.: **ONE**

Data Sheet No. PES-145-06-DS1-0

DATA SHEET – A & B

DATA SHEET – A FOR CONTROL VALVE (WITH PNEUMATIC ACTUATOR) (TO BE FILLED BY PURCHASER)		DATA SHEET – B (TO BE FILLED UP BY BIDDER)
GENERAL*	PROJECT SERVICE LOCATION DUTY PIPE SIZE (inlet / outlet) PIPE MATERIAL (inlet / outlet)	4X270 MW MANUGURU TPS DEAERATOR LEVEL CONTROL <input checked="" type="checkbox"/> INDOOR <input type="checkbox"/> OUTDOOR <input type="checkbox"/> ON/OFF <input checked="" type="checkbox"/> MODULATING Ø 323.9 X 9.53 Ø 323.9 X 9.53 SA 106 Gr B SA 106 Gr B
BODY*	MODEL NO. TYPE OF BODY: GUIDING : NO. OF PORTS BODY SIZE: PORT SIZE: DESIGN CV END CONNECTION & RATING (ANSI) BODY MATERIAL PACKING: MATERIAL SINGLE / DOUBLE BONNET TYPE TRIM FORM TRIM MATERIAL: SEAT PLUG : CAGE GUIDE BUSH FLOW OUTLET VELOCITY REQUIRED LEAKAGE CLASS NOISE LEVEL (dBA) (spec. 3.1.14) VACUUM SERVICE ANTI CAVITATION TRIM	<input checked="" type="checkbox"/> GLOBE <input type="checkbox"/> ANGLE <input type="checkbox"/> TOP <input checked="" type="checkbox"/> CAGE ONE <input checked="" type="checkbox"/> BWE <input type="checkbox"/> SWE <input type="checkbox"/> FLANGED <input checked="" type="checkbox"/> A216 WCB <input type="checkbox"/> A217 WC6 <input type="checkbox"/> SS <input type="checkbox"/> A217 C5 <input type="checkbox"/> A351 CF8M <input type="checkbox"/> PTFE <input checked="" type="checkbox"/> GRAFOIL <input type="checkbox"/> DOUBLE <input checked="" type="checkbox"/> SINGLE <input type="checkbox"/> STD <input type="checkbox"/> EXTENDED <input type="checkbox"/> FINNED <input type="checkbox"/> LINEAR <input checked="" type="checkbox"/> EQ. PERCENTAGE <input type="checkbox"/> QUICK OPEN (ON/OFF) SS 316 STELLITED SS 316 STELLITED 17-4 PH SS SS 316 STELLITED <input type="checkbox"/> BELOW SEAT <input type="checkbox"/> ABOVE SEAT <input type="checkbox"/> < 7 M/SEC (WATER) <input type="checkbox"/> MAC NO. < 1/3 (STM) <input type="checkbox"/> II <input type="checkbox"/> III <input type="checkbox"/> IV <input checked="" type="checkbox"/> V <input type="checkbox"/> VI LESS THAN 85 dBA <input type="checkbox"/> YES <input checked="" type="checkbox"/> NO <input type="checkbox"/> YES <input checked="" type="checkbox"/> NO
PNEUMATIC ACTUATOR	MODEL NO. & SIZE CLOSE AT : OPEN AT (KG/CM2g) *TRAVEL TIME FOR OPEN TO CLOSE, CLOSE TO OPEN *VLV POSN. ON ELEC SIGNAL FAILURE *VALVE POSN. ON SUPPLY AIR FAILURE	< 20 SEC <input type="checkbox"/> TO OPEN <input type="checkbox"/> STAYPUT <input checked="" type="checkbox"/> TO CLOSE <input checked="" type="checkbox"/> STAYPUT
ACCESSORIES	POSITIONER(SMART)HART COMPATIBLE AIR FILTER REGULATOR AIR LOCK RELAY POSITION LIMIT SWITCH POSITION TRANSMITTER SOLENOID VALVE E/P CONVERTOR JUNCTION BOX HAND WHEEL (SIDE MOUNTED) LOCAL POSITION INDICATOR PRESSURE GAUGES	<input checked="" type="checkbox"/> REQUIRED <input type="checkbox"/> NOT REQUIRED <input checked="" type="checkbox"/> REQUIRED <input type="checkbox"/> NOT REQUIRED <input checked="" type="checkbox"/> REQUIRED <input type="checkbox"/> NOT REQUIRED <input type="checkbox"/> REQUIRED <input checked="" type="checkbox"/> NOT REQUIRED PART OF POSITIONER <input type="checkbox"/> REQUIRED <input checked="" type="checkbox"/> NOT REQUIRED PART OF POSITIONER <input checked="" type="checkbox"/> REQUIRED <input type="checkbox"/> NOT REQUIRED <input checked="" type="checkbox"/> REQUIRED <input checked="" type="checkbox"/> REQUIRED <input checked="" type="checkbox"/> REQUIRED <input type="checkbox"/> NOT REQUIRED



**4X270 MW MANUGURU TPS
DATA SHEET FOR CONTROL VALVES
(WITH PNEUMATIC ACTUATOR)**

SPECIFICATION NO.: PE-TS-411-145-1104A	
VOLUME	
SECTION	
REV. NO. 1	DATE : 13.02.15
SHEET	

Tag No.: **CD-21** Qty.: **ONE**

Data Sheet No. PES-145-06-DS1-0

DATA SHEET – A & B

DATA SHEET – A FOR CONTROL VALVE (WITH PNEUMATIC ACTUATOR) (TO BE FILLED BY PURCHASER)		DATA SHEET – B (TO BE FILLED UP BY BIDDER)
GENERAL*	PROJECT SERVICE LOCATION DUTY PIPE SIZE (inlet / outlet) PIPE MATERIAL (inlet / outlet)	4X270 MW MANUGURU TPS EXCESS RETURN TO CST <input type="checkbox"/> INDOOR <input type="checkbox"/> OUTDOOR <input type="checkbox"/> ON/OFF <input checked="" type="checkbox"/> MODULATING Ø 168.3x7.11 Ø 168.3x7.11 SA 106 Gr B SA 106 Gr B
BODY*	MODEL NO. TYPE OF BODY: GUIDING : NO. OF PORTS BODY SIZE: PORT SIZE: DESIGN CV END CONNECTION & RATING (ANSI) BODY MATERIAL PACKING: MATERIAL SINGLE / DOUBLE BONNET TYPE TRIM FORM TRIM MATERIAL: SEAT PLUG : CAGE GUIDE BUSH FLOW OUTLET VELOCITY REQUIRED LEAKAGE CLASS NOISE LEVEL (dBA) (spec. 3.1.14) VACUUM SERVICE ANTI CAVITATION TRIM	<input checked="" type="checkbox"/> GLOBE <input type="checkbox"/> ANGLE <input type="checkbox"/> TOP <input checked="" type="checkbox"/> CAGE ONE <input checked="" type="checkbox"/> BWE <input type="checkbox"/> SWE <input type="checkbox"/> FLANGED <input checked="" type="checkbox"/> A216 WCB <input type="checkbox"/> A217 WC6 <input type="checkbox"/> SS <input type="checkbox"/> A217 C5 <input type="checkbox"/> A351 CF8M <input type="checkbox"/> PTFE <input checked="" type="checkbox"/> GRAFOIL <input type="checkbox"/> DOUBLE <input checked="" type="checkbox"/> SINGLE <input type="checkbox"/> STD <input type="checkbox"/> EXTENDED <input type="checkbox"/> FINNED <input type="checkbox"/> LINEAR <input checked="" type="checkbox"/> EQ. PERCENTAGE <input type="checkbox"/> QUICK OPEN (ON/OFF) SS 316 STELLITED SS 316 STELLITED 17-4 PH SS SS 316 STELLITED <input type="checkbox"/> BELOW SEAT <input type="checkbox"/> ABOVE SEAT <input type="checkbox"/> < 7 M/SEC (WATER) <input type="checkbox"/> MAC NO. < 1/3 (STM) <input type="checkbox"/> II <input type="checkbox"/> III <input checked="" type="checkbox"/> IV <input type="checkbox"/> V <input type="checkbox"/> VI LESS THAN 85 dBA <input type="checkbox"/> YES <input checked="" type="checkbox"/> NO <input type="checkbox"/> YES <input checked="" type="checkbox"/> NO
PNEUMATIC ACTUATOR	MODEL NO. & SIZE CLOSE AT : OPEN AT (KG/CM2g) *TRAVEL TIME FOR OPEN TO CLOSE, CLOSE TO OPEN *VLV POSN. ON ELEC SIGNAL FAILURE *VALVE POSN. ON SUPPLY AIR FAILURE	< 20 SEC <input type="checkbox"/> TO OPEN <input checked="" type="checkbox"/> STAYPUT <input type="checkbox"/> TO CLOSE <input checked="" type="checkbox"/> STAYPUT
ACCESSORIES	POSITIONER(SMART)HART COMPATIBLE AIR FILTER REGULATOR AIR LOCK RELAY POSITION LIMIT SWITCH POSITION TRANSMITTER SOLENOID VALVE E/P CONVERTOR JUNCTION BOX HAND WHEEL (SIDE MOUNTED) LOCAL POSITION INDICATOR PRESSURE GAUGES	<input checked="" type="checkbox"/> REQUIRED <input type="checkbox"/> NOT REQUIRED <input checked="" type="checkbox"/> REQUIRED <input type="checkbox"/> NOT REQUIRED <input checked="" type="checkbox"/> REQUIRED <input type="checkbox"/> NOT REQUIRED <input type="checkbox"/> REQUIRED <input checked="" type="checkbox"/> NOT REQUIRED PART OF POSITIONER <input checked="" type="checkbox"/> REQUIRED <input type="checkbox"/> NOT REQUIRED PART OF POSITIONER <input checked="" type="checkbox"/> REQUIRED <input type="checkbox"/> NOT REQUIRED <input checked="" type="checkbox"/> REQUIRED <input checked="" type="checkbox"/> REQUIRED <input checked="" type="checkbox"/> REQUIRED <input type="checkbox"/> NOT REQUIRED



**4X270 MW MANUGURU TPS
DATA SHEET FOR CONTROL VALVES
(WITH PNEUMATIC ACTUATOR)**

SPECIFICATION NO.: PE-TS-411-145-I104A

VOLUME

SECTION

REV. NO.

1

DATE : 13.02.15

SHEET

Tag No.: **DR-2** Qty.: **ONE**

Data Sheet No. PES-145-06-DS1-0

DATA SHEET – A & B

**DATA SHEET – A FOR CONTROL VALVE (WITH PNEUMATIC ACTUATOR)
(TO BE FILLED BY PURCHASER)**

**DATA SHEET – B
(TO BE FILLED UP BY
BIDDER)**

PERFORMANCE OF VALVE	LINEARITY			HYSTERISIS			SENSITIVITY			ACCURACY (OVERALL)		
	± 2%			± 1%			± 0.5%			± 2%		
SERVICE CONDITION*	SL. No. +	LOAD	FLOW (T/HR)	INLET PR. KG/CM2(A)	OUTLET PR. KG/CM2(A)	TEMP DEG °C	CALCULATED CV	% VALVE LIFT	VALVE O/L VELOCITY			
	1.	VWO	81.2	39.2	16.7	207.5						
	2.	100%	73.4	37.7	16.2	205.9						
	3.	60%	37.5	23.9	10.3	185.4						
	VALVE TYPE							<input type="checkbox"/> CAVITATION <input type="checkbox"/> FLASHING <input type="checkbox"/> HIGH DP				
	* MAX SHUT OFF PRESS (KG/CM2g) 47										
* BODY DESIGN : PRESS (KG/CM2g) TEMP (DEG C) 47 215											
* IBR FORM III-C <input checked="" type="checkbox"/> REQUIRED <input type="checkbox"/> NOT REQUIRED											
TOTAL WEIGHT (VALVE + ACTUATOR + ACCESSORIES) Kg											

NOTES:



**4X270 MW MANUGURU TPS
DATA SHEET FOR CONTROL VALVES
(WITH PNEUMATIC ACTUATOR)**

SPECIFICATION NO.: PE-TS-411-145-1104A	
VOLUME	
SECTION	
REV. NO. 1	DATE : 13.02.15
SHEET	

Tag No.: **DR-9** Qty.: **ONE**

Data Sheet No. PES-145-06-DS1-0

DATA SHEET – A & B

DATA SHEET – A FOR CONTROL VALVE (WITH PNEUMATIC ACTUATOR)
(TO BE FILLED BY PURCHASER)

DATA SHEET – B
(TO BE FILLED UP BY
BIDDER)

PERFORMANCE OF VALVE	LINEARITY	± 2%
	HYSTERISIS	± 1%	
	SENSITIVITY	± 0.5%
	ACCURACY (OVERALL)	± 2%

SERVICE CONDITION*	SL. No. +	LOAD	FLOW (T/HR)	INLET PR. KG/CM2(A)	OUTLET PR. KG/CM2(A)	TEMP DEG ©	CALCULATED CV	% VALVE LIFT	VALVE O/L VELOCITY
	1.	VWO	81.2	40.4	0.3	207.5			
	2.	100%	73.4	38.9	0.3	205.9			
	3.	60%	37.5	25.1	0.1	185.4			
	4.	MAX	115	35	0.3	173			
VALVE TYPE							<input type="checkbox"/> CAVITATION <input checked="" type="checkbox"/> FLASHING <input type="checkbox"/> HIGH DP		
* MAX SHUT OFF PRESS (KG/CM2g)					47/VAC			
* BODY DESIGN : PRESS (KG/CM2g) TEMP (DEG C)					47/VAC 215			
* IBR FORM III-C					<input checked="" type="checkbox"/> REQUIRED <input type="checkbox"/> NOT REQUIRED			
TOTAL WEIGHT (VALVE + ACTUATOR + ACCESSORIES) Kg								



**4X270 MW MANUGURU TPS
DATA SHEET FOR CONTROL VALVES
(WITH PNEUMATIC ACTUATOR)**

SPECIFICATION NO.: PE-TS-411-145-I104A

VOLUME

SECTION

REV. NO.

1

DATE : 13.02.15

SHEET

Tag No.: **DR-13** Qty.: **ONE**

Data Sheet No. PES-145-06-DS1-0

DATA SHEET – A & B

DATA SHEET – A FOR CONTROL VALVE (WITH PNEUMATIC ACTUATOR)
(TO BE FILLED BY PURCHASER)

DATA SHEET – B
(TO BE FILLED UP BY
BIDDER)

PERFORMANCE OF VALVE	LINEARITY		± 2%						
	HYSTERISIS		± 1%							
SENSITIVITY		± 0.5%								
ACCURACY (OVERALL)		± 2%								
SERVICE CONDITION*	SL. No. +	LOAD	FLOW (T/HR)	INLET PR. KG/CM2(A)	OUTLET PR. KG/CM2(A)	TEMP DEG (C)	CALCULATED CV	% VALVE LIFT	VALVE O/L VELOCITY	
	1.	VWO	128	15.2	6.8	171.9				
	2.	100%	116	14.6	6.8	170.9				
	3.	60%	61.5	8.8	4.3	152.5				
	VALVE TYPE							<input type="checkbox"/> CAVITATION <input checked="" type="checkbox"/> FLASHING <input type="checkbox"/> HIGH DP		
	* MAX SHUT OFF PRESS (KG/CM2g) 19								
* BODY DESIGN : PRESS (KG/CM2g) TEMP (DEG C) 19 175									
* IBR FORM III-C <input checked="" type="checkbox"/> REQUIRED <input type="checkbox"/> NOT REQUIRED									
TOTAL WEIGHT (VALVE + ACTUATOR + ACCESSORIES) Kg									

NOTES:



**4X270 MW MANUGURU TPS
DATA SHEET FOR CONTROL VALVES
(WITH PNEUMATIC ACTUATOR)**

SPECIFICATION NO.: PE-TS-411-145-1104A	
VOLUME	
SECTION	
REV. NO. 1	DATE : 13.02.15
SHEET	

Tag No.: **DR-16** Qty.: **ONE**

Data Sheet No. PES-145-06-DS1-0

DATA SHEET – A & B

DATA SHEET – A FOR CONTROL VALVE (WITH PNEUMATIC ACTUATOR)
(TO BE FILLED BY PURCHASER)

DATA SHEET – B
(TO BE FILLED UP BY
BIDDER)

PERFORMANCE OF VALVE	LINEARITY	± 2%
	HYSTERISIS	± 1%	
	SENSITIVITY	± 0.5%
	ACCURACY (OVERALL)	± 2%

SERVICE CONDITION*	SL. No. +	LOAD	FLOW (T/HR)	INLET PR. KG/CM2(A)	OUTLET PR. KG/CM2(A)	TEMP DEG (C)	CALCULATED CV	% VALVE LIFT	VALVE O/L VELOCITY
	1.	VWO	128	17.9	0.3	171.9			
	2.	100%	116	17.4	0.3	170.9			
	3.	60%	61.5	11.5	0.2	152.5			
VALVE TYPE							<input type="checkbox"/> CAVITATION <input checked="" type="checkbox"/> FLASHING <input type="checkbox"/> HIGH DP		
* MAX SHUT OFF PRESS (KG/CM2g)					19/VAC			
* BODY DESIGN : PRESS (KG/CM2g) TEMP (DEG C)					19/VAC 175			
* IBR FORM III-C					<input checked="" type="checkbox"/> REQUIRED <input type="checkbox"/> NOT REQUIRED			

TOTAL WEIGHT (VALVE + ACTUATOR + ACCESSORIES) Kg

NOTES:



**4X270 MW MANUGURU TPS
DATA SHEET FOR CONTROL VALVES
(WITH PNEUMATIC ACTUATOR)**

SPECIFICATION NO.: PE-TS-411-145-1104A	
VOLUME	
SECTION	
REV. NO. 1	DATE : 13.02.15
SHEET	

Tag No.: **DR-19** Qty.: **ONE**

Data Sheet No. PES-145-06-DS1-0

DATA SHEET – A & B

**DATA SHEET – A FOR CONTROL VALVE (WITH PNEUMATIC ACTUATOR)
(TO BE FILLED BY PURCHASER)**

**DATA SHEET – B
(TO BE FILLED UP BY
BIDDER)**

PERFORMANCE OF VALVE	LINEARITY	± 2%
	HYSTERISIS	± 1%	
	SENSITIVITY	± 0.5%
	ACCURACY (OVERALL)	± 2%

SERVICE CONDITION*	SL. No. +	LOAD	FLOW (T/HR)	INLET PR. KG/CM2(A)	OUTLET PR. KG/CM2(A)	TEMP DEG (C)	CALCULATED CV	% VALVE LIFT	VALVE O/L VELOCITY
	1.	VWO	34.1	2.5	0.96	100.1			
	2.	100%	31.2	2.4	0.94	99.4			
	3.	60%	17.6	1.6	0.61	87.6			
VALVE TYPE							<input type="checkbox"/> CAVITATION <input checked="" type="checkbox"/> FLASHING <input type="checkbox"/> HIGH DP		
* MAX SHUT OFF PRESS (KG/CM2g)					7/VAC			
* BODY DESIGN : PRESS (KG/CM2g) TEMP (DEG C)					7/VAC 130			
* IBR FORM III-C					<input checked="" type="checkbox"/> REQUIRED <input type="checkbox"/> NOT REQUIRED			

TOTAL WEIGHT (VALVE + ACTUATOR + ACCESSORIES) Kg

NOTES:



**4X270 MW MANUGURU TPS
DATA SHEET FOR CONTROL VALVES
(WITH PNEUMATIC ACTUATOR)**

SPECIFICATION NO.: PE-TS-411-145-1104A	
VOLUME	
SECTION	
REV. NO. 1	DATE : 13.02.15
SHEET	

Tag No.: **DR-22** Qty.: **ONE**

Data Sheet No. PES-145-06-DS1-0

DATA SHEET – A & B

DATA SHEET – A FOR CONTROL VALVE (WITH PNEUMATIC ACTUATOR)
(TO BE FILLED BY PURCHASER)

DATA SHEET – B
(TO BE FILLED UP BY
BIDDER)

PERFORMANCE OF VALVE	LINEARITY	± 2%
	HYSTERISIS	± 1%	
	SENSITIVITY	± 0.5%
	ACCURACY (OVERALL)	± 2%

SERVICE CONDITION*	SL. No. +	LOAD	FLOW (T/HR)	INLET PR. KG/CM2(A)	OUTLET PR. KG/CM2(A)	TEMP DEG (C)	CALCULATED CV	% VALVE LIFT	VALVE O/L VELOCITY
	1.	VWO	34.1	2.9	0.1	100.1			
	2.	100%	31.2	2.9	0.1	99.4			
	3.	60%	17.6	2.1	0.1	87.6			
	4.	MAX	45	2.2	0.1	84			
VALVE TYPE							<input type="checkbox"/> CAVITATION <input checked="" type="checkbox"/> FLASHING <input type="checkbox"/> HIGH DP		
* MAX SHUT OFF PRESS (KG/CM2g)					7/VAC			
* BODY DESIGN : PRESS (KG/CM2g) TEMP (DEG C)					7/VAC 130			
* IBR FORM III-C					<input checked="" type="checkbox"/> REQUIRED <input type="checkbox"/> NOT REQUIRED			

TOTAL WEIGHT (VALVE + ACTUATOR + ACCESSORIES) Kg

NOTES:



**4X270 MW MANUGURU TPS
DATA SHEET FOR CONTROL VALVES
(WITH PNEUMATIC ACTUATOR)**

SPECIFICATION NO.: PE-TS-411-145-1104A

VOLUME

SECTION

REV. NO.

1

DATE : 13.02.15

SHEET

Tag No.: **DR-25** Qty.: **ONE**

Data Sheet No. PES-145-06-DS1-0

DATA SHEET – A & B

DATA SHEET – A FOR CONTROL VALVE (WITH PNEUMATIC ACTUATOR)
(TO BE FILLED BY PURCHASER)

DATA SHEET – B
(TO BE FILLED UP BY
BIDDER)

PERFORMANCE OF VALVE	LINEARITY	± 2%
	HYSTERISIS	± 1%	
	SENSITIVITY	± 0.5%
	ACCURACY (OVERALL)	± 2%

SERVICE CONDITION*	SL. No. +	LOAD	FLOW (T/HR)	INLET PR. KG/CM2(A)	OUTLET PR. KG/CM2(A)	TEMP DEG (C)	CALCULATED CV	% VALVE LIFT	VALVE O/L VELOCITY
	1.	VWO	60.8	0.98	0.39	77			
	2.	100%	55.5	0.96	0.39	76.7			
	3.	60%	30.1	0.63	0.27	68.4			
VALVE TYPE							<input type="checkbox"/> CAVITATION <input type="checkbox"/> FLASHING <input type="checkbox"/> HIGH DP		
* MAX SHUT OFF PRESS (KG/CM2g)					7/VAC			
* BODY DESIGN : PRESS (KG/CM2g) TEMP (DEG C)					7/VAC 105			
* IBR FORM III-C					<input type="checkbox"/> REQUIRED <input type="checkbox"/> NOT REQUIRED			
TOTAL WEIGHT (VALVE + ACTUATOR + ACCESSORIES) Kg								

NOTES:



**4X270 MW MANUGURU TPS
DATA SHEET FOR CONTROL VALVES
(WITH PNEUMATIC ACTUATOR)**

SPECIFICATION NO.: PE-TS-411-145-1104A

VOLUME

SECTION

REV. NO.

1

DATE : 13.02.15

SHEET

Tag No.: **DR-28** Qty.: **ONE**

Data Sheet No. PES-145-06-DS1-0

DATA SHEET – A & B

DATA SHEET – A FOR CONTROL VALVE (WITH PNEUMATIC ACTUATOR)
(TO BE FILLED BY PURCHASER)

DATA SHEET – B
(TO BE FILLED UP BY
BIDDER)

PERFORMANCE OF VALVE	LINEARITY	± 2%
	HYSTERISIS	± 1%	
	SENSITIVITY	± 0.5%
	ACCURACY (OVERALL)	± 2%

SERVICE CONDITION*	SL. No. +	LOAD	FLOW (T/HR)	INLET PR. KG/CM2(A)	OUTLET PR. KG/CM2(A)	TEMP DEG (C)	CALCULATED CV	% VALVE LIFT	VALVE O/L VELOCITY
	1.	VWO	60.85	1.5	0.1	77			
	2.	100%	55.5	1.4	0.1	76.7			
	3.	60%	30.1	1.1	0.1	68.4			
	4.	MAX	80	0.9	0.1	57.3			
VALVE TYPE							<input type="checkbox"/> CAVITATION <input checked="" type="checkbox"/> FLASHING <input type="checkbox"/> HIGH DP		
* MAX SHUT OFF PRESS (KG/CM2g)					7/VAC			
* BODY DESIGN : PRESS (KG/CM2g) TEMP (DEG C)					7/VAC 105			
* IBR FORM III-C					<input checked="" type="checkbox"/> REQUIRED <input type="checkbox"/> NOT REQUIRED			
TOTAL WEIGHT (VALVE + ACTUATOR + ACCESSORIES) Kg								

NOTES:



**4X270 MW MANUGURU TPS
DATA SHEET FOR CONTROL VALVES
(WITH PNEUMATIC ACTUATOR)**

SPECIFICATION NO.: PE-TS-411-145-1104A	
VOLUME	
SECTION	
REV. NO. 1	DATE : 13.02.15
SHEET	

Tag No.: **DR-38** Qty.: **ONE**

Data Sheet No. PES-145-06-DS1-0

DATA SHEET – A & B

DATA SHEET – A FOR CONTROL VALVE (WITH PNEUMATIC ACTUATOR)
(TO BE FILLED BY PURCHASER)

DATA SHEET – B
(TO BE FILLED UP BY
BIDDER)

PERFORMANCE OF VALVE	LINEARITY	± 2%
	HYSTERISIS	± 1%	
	SENSITIVITY	± 0.5%
	ACCURACY (OVERALL)	± 2%

SERVICE CONDITION*	SL. No. +	LOAD	FLOW (T/HR)	INLET PR. KG/CM2(A)	OUTLET PR. KG/CM2(A)	TEMP DEG (C)	CALCULATED CV	% VALVE LIFT	VALVE O/L VELOCITY
		1.	MAXIMUM	90	9.0	0.11	159.7		
VALVE TYPE							<input type="checkbox"/> CAVITATION <input checked="" type="checkbox"/> FLASHING <input type="checkbox"/> HIGH DP		
* MAX SHUT OFF PRESS (KG/CM2g)					10/VAC			
* BODY DESIGN : PRESS (KG/CM2g) TEMP (DEG C)					10/VAC 170			
* IBR FORM III-C					<input checked="" type="checkbox"/> REQUIRED <input type="checkbox"/> NOT REQUIRED			
TOTAL WEIGHT (VALVE + ACTUATOR + ACCESSORIES) Kg								

NOTES:



**4X270 MW MANUGURU TPS
DATA SHEET FOR CONTROL VALVES
(WITH PNEUMATIC ACTUATOR)**

SPECIFICATION NO.: PE-TS-411-145-I104A	
VOLUME	
SECTION	
REV. NO. 1	DATE : 13.02.15
SHEET	

Tag No.: **DM-15** Qty.: **ONE**

Data Sheet No. PES-145-06-DS1-0

DATA SHEET – A & B

DATA SHEET – A FOR CONTROL VALVE (WITH PNEUMATIC ACTUATOR) (TO BE FILLED BY PURCHASER)		DATA SHEET – B (TO BE FILLED UP BY BIDDER)
GENERAL*	<p>PROJECT SERVICE LOCATION DUTY PIPE SIZE (inlet / outlet) PIPE MATERIAL (inlet / outlet)</p>	<p>4X270 MW MANUGURU TPS EMERGENCY MAKE-UP TO CONDENSER <input type="checkbox"/> INDOOR <input type="checkbox"/> OUTDOOR <input type="checkbox"/> ON/OFF <input checked="" type="checkbox"/> MODULATING Ø 114.3X3.05 Ø 114.3X3.05 SA 106 Gr C SA 106 Gr C</p>
BODY*	<p>MODEL NO. TYPE OF BODY: GUIDING : NO. OF PORTS BODY SIZE: PORT SIZE: DESIGN CV END CONNECTION & RATING (ANSI) BODY MATERIAL</p> <p>PACKING: MATERIAL SINGLE / DOUBLE BONNET TYPE TRIM FORM</p> <p>TRIM MATERIAL: SEAT PLUG : CAGE GUIDE BUSH</p> <p>FLOW OUTLET VELOCITY</p> <p>REQUIRED LEAKAGE CLASS NOISE LEVEL (dBA) (spec. 3.1.14) VACUUM SERVICE ANTI CAVITATION TRIM</p>	<p><input checked="" type="checkbox"/> GLOBE <input type="checkbox"/> ANGLE <input type="checkbox"/> TOP <input checked="" type="checkbox"/> CAGE ONE</p> <p><input checked="" type="checkbox"/> BWE <input type="checkbox"/> SWE <input type="checkbox"/> FLANGED <input type="checkbox"/> A216 WCB <input type="checkbox"/> A217 WC6 <input type="checkbox"/> SS <input type="checkbox"/> A217 C5 <input checked="" type="checkbox"/> A351 CF8M <input type="checkbox"/> PTFE <input checked="" type="checkbox"/> GRAFOIL <input type="checkbox"/> DOUBLE <input checked="" type="checkbox"/> SINGLE <input type="checkbox"/> STD <input type="checkbox"/> EXTENDED <input type="checkbox"/> FINNED <input type="checkbox"/> LINEAR <input checked="" type="checkbox"/> EQ. PERCENTAGE <input type="checkbox"/> QUICK OPEN (ON/OFF) SS 316 STELLITED SS 316 STELLITED 17-4 PH SS SS 316 STELLITED <input type="checkbox"/> BELOW SEAT <input type="checkbox"/> ABOVE SEAT <input type="checkbox"/> < 7 M/SEC (WATER) <input type="checkbox"/> MAC NO. < 1/3 (STM)</p> <p><input type="checkbox"/> II <input type="checkbox"/> III <input type="checkbox"/> IV <input checked="" type="checkbox"/> V <input type="checkbox"/> VI LESS THAN 85 dBA <input checked="" type="checkbox"/> YES <input type="checkbox"/> NO <input checked="" type="checkbox"/> YES <input type="checkbox"/> NO</p>
PNEUMATIC ACTUATOR	<p>MODEL NO. & SIZE CLOSE AT : OPEN AT (KG/CM2g) *TRAVEL TIME FOR OPEN TO CLOSE, CLOSE TO OPEN *VLV POSN. ON ELEC SIGNAL FAILURE *VALVE POSN. ON SUPPLY AIR FAILURE</p>	<p>< 20 SEC <input type="checkbox"/> TO OPEN <input checked="" type="checkbox"/> STAYPUT <input type="checkbox"/> TO CLOSE <input checked="" type="checkbox"/> STAYPUT</p>
ACCESSORIES	<p>POSITIONER(SMART)HART COMPATIBLE AIR FILTER REGULATOR AIR LOCK RELAY POSITION LIMIT SWITCH POSITION TRANSMITTER SOLENOID VALVE E/P CONVERTOR JUNCTION BOX HAND WHEEL (SIDE MOUNTED) LOCAL POSITION INDICATOR PRESSURE GAUGES</p>	<p><input checked="" type="checkbox"/> REQUIRED <input type="checkbox"/> NOT REQUIRED <input checked="" type="checkbox"/> REQUIRED <input type="checkbox"/> NOT REQUIRED <input checked="" type="checkbox"/> REQUIRED <input type="checkbox"/> NOT REQUIRED <input type="checkbox"/> REQUIRED <input checked="" type="checkbox"/> NOT REQUIRED PART OF POSITIONER <input type="checkbox"/> REQUIRED <input checked="" type="checkbox"/> NOT REQUIRED PART OF POSITIONER <input checked="" type="checkbox"/> REQUIRED <input type="checkbox"/> NOT REQUIRED <input checked="" type="checkbox"/> REQUIRED <input checked="" type="checkbox"/> REQUIRED <input checked="" type="checkbox"/> REQUIRED <input type="checkbox"/> NOT REQUIRED</p>



**Technical specification for
Control Valves with Accessories
(Pneumatically Operated)**

Tag No..... Quantity.....

APPLICABLE FOR TAG Nos.WHEREVER STATEMENT "REQUIRED" INDICATED IN THE INDIVIDUAL CV DATA SHEETS

DATA SHEET – A& B for ACCESSORIES

**DATA SHEET – A FOR CONTROL VALVE (WITH PNEUMATIC ACTUATOR)
(TO BE FILLED BY PURCHASER)**

**DATA SHEET – B
(TO BE FILLED-UP BY BIDDER)**

POSITIONER	MFR. & MODEL NUMBER				
	BYPASS	GAUGES	ENCL. CLASS	<input checked="" type="checkbox"/> YES <input type="checkbox"/> NO	<input checked="" type="checkbox"/> THREE <input type="checkbox"/> TWO <input checked="" type="checkbox"/> IP-55
	INPUT SIGNAL (Kg / Cm ²)		<input checked="" type="checkbox"/> 0.2 – 1.0 <input type="checkbox"/> 0.2 – 0.6 <input type="checkbox"/> 0.6 – 1.0		
	OUTPUT SIGNAL (Kg / Cm ²)		TO SUIT ACTUATOR		
AIR FILTER REGULATOR TWO (2) Nos. PER CV	MFR. & MODEL NUMBER				
	AIR SUPPLY PRESS (Kg / Cm ² g)		<input checked="" type="checkbox"/> 7.0 <input type="checkbox"/>		
	OUTPUT PRESS (Kg / Cm ² g)		TO SUIT ACTUATOR		
	FILTER SIZE		5 MICRON		
AIR LOCK	MFR. & MODEL NUMBER				
	SET PRESS (Kg / Cm ²)				
	SUPPLY PRESS (Kg / Cm ²)		<input checked="" type="checkbox"/> 7.0 <input type="checkbox"/>		
	RESET TYPE		AUTO		
LIMIT SWITCH	MFR. & MODEL NUMBER				
	OPEN posn	INT posn	CLOSE posn	1 NO.	---
	CONTACT TYPE		SPDT 2 NO + 2 NC		
	RATING (AC / DC)		5A 240V AC AND 0.2A 220V DC		
POSITION TRANSMITTER	MFR. & MODEL NUMBER		<input checked="" type="checkbox"/> Electronic (2-Wire) Contactless <input type="checkbox"/> OTHER		
	TYPE		PART OF SMART POSITIONER		
	SUPPLY				
	OUTPUT RATING				
	ACCURACY				
	ENCLOSURE CLASS				
SOLENOID VALVE	MFR. & MODEL NUMBER				
	RATING		<input checked="" type="checkbox"/> 24V DC <input type="checkbox"/> 220V DC <input type="checkbox"/> 240V AC <input type="checkbox"/>		
	TYPE		3-WAY (UNIVERSAL OPERATION TYPE)		
	OPERATION	QUANTITY	<input type="checkbox"/> Stayput <input type="checkbox"/> Interlock <input type="checkbox"/> 1 <input type="checkbox"/> 2		
	COIL INSULATION CLASS		CLASS - F		
HANDWHEEL	ENCLOSURE CLASS		<input checked="" type="checkbox"/> IP 65 <input type="checkbox"/> NEMA 4 <input type="checkbox"/>		
	ORIENTATION		<input type="checkbox"/> TOP MOUNTED <input checked="" type="checkbox"/> SIDE MOUNTED		
JUNCTION BOX	NO. OF WAYS		<input type="checkbox"/> 24-WAYS <input type="checkbox"/> AS REQUIRED <input checked="" type="checkbox"/> 36-Ways		
	SIZE		AS REQUIRED		
	CABLE GLANDS (Size / Quantity)		AS REQUIRED (Double Compression Type).		
	ENCLOSURE CLASS		<input checked="" type="checkbox"/> IP 65 <input type="checkbox"/>		
I/P CONVERTER	INPUT SIGNAL	POWER SUPPLY	PART OF SMART POSITIONER		
	SPLIT RANGE				
	ENCLOSURE CLASS				
	LINEARITY				
	HYSTERISIS				
Cu. Tubing & Fittings / per CV	This is in addition to cu. Tubing and fittings which are integral part of CV		25 Meters of ¼" PVC coated Cu. Tubing, with 1 set of Fittings for each CV for connection to IA Header on one end and accessories on another end of CV.		



COMPANY SEAL

NAME

SIGNATURE

DATE

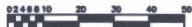
STANDARD HOOK UP DIAGRAM FOR PNEUMATICALLY OPERATED CONTROL VALVE

JOB NO. 999					PROJECT					STANDARD						
STATUS STANDARD																
PRINT SCALE 					 BHARAT HEAVY ELECTRICALS LTD POWER SECTOR PROJECT ENGINEERING MANAGEMENT NOIDA					DEPT		NAME	SIGN	DATE		
REV	DATE	ALTD	CHKD	APPD						CODE	I	DESIGN	PJ/RV	[Signature]	08.12.14	
							CHD	CM	[Signature]	08.12.14						
							APPD	DP	[Signature]	08.12.14						
					TITLE :-					STANDARD HOOK UP DIAGRAM FOR PNEUMATICALLY OPERATED CONTROL VALVE						
										DEPT.	SCALE	DRAWING/DOC. NO.				
										SIGN		PES-145-06B				
										DATE		SHEET 1 OF 7 REV. 00				

INDEX

Sl. No.	DISCRIPTION	SHEET NO.
1	TITLE SHEET	1
2	INDEX & LEGEND	2
3	CV HOOK-UP DIAGRAM	
3.1	FOR CONVENTIONAL POSITIONER	3
3.2	FOR SMART POSITIONER	4
3.3	FOR ON / OFF TYPE VALVE	5
3.4	FOR DOUBLE ACTING PISTON WITH CONVENTIONAL POSITIONER	6
3.5	FOR DOUBLE ACTING PISTON WITH SMART POSITIONER	7

LEGEND

PG	PRESSURE GAUGE
VB	VOLUME BOOSTER
SOV	SOLENOID OPERATED VALVE
I/P	CURRENT TO PNEUMATIC CONVERTER
JB	JUNCTION BOX
LS	LEVEL SWITCH
AIR SET	AIR FILTER REGULATOR



STANDARD

DRG.
No.

PES-145-06B

TITLE:-

CONTROL VALVE HOOK-UP DIAGRAM

REV.
No.

0

DATE

08.12.14

SHEET

2

OF

7

STANDARD CONTROL VALVE HOOK-UP DIAGRAM (WITH CONVENTIONAL POSITIONER)

Not Applicable

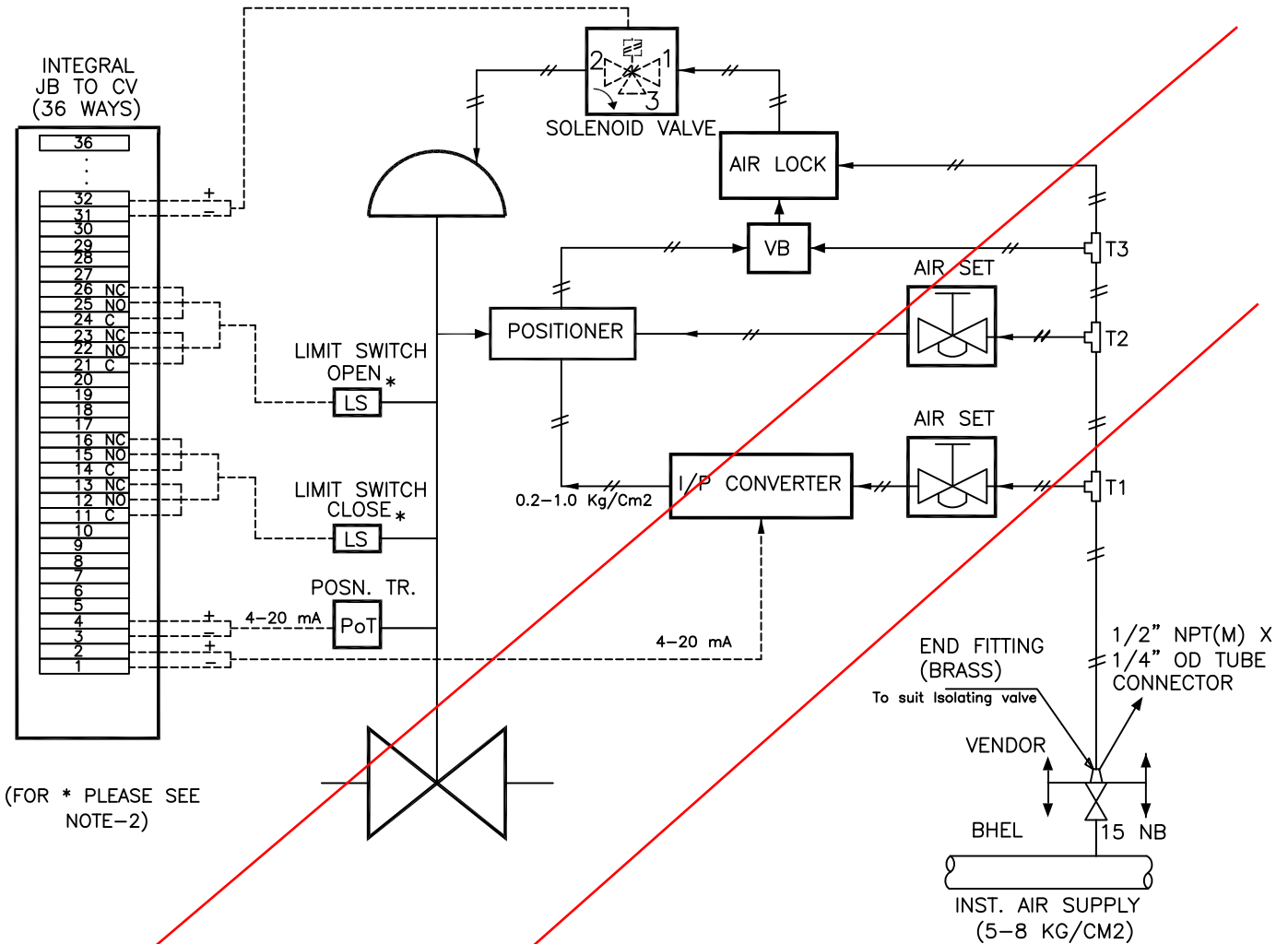

NOTES :-

1. POSITION OF EACH VALVE ON SUPPLY AIR FAILURE / SIGNAL AIR FAILURE SHALL BE AS PER SPECIFICATION / DATA SHEET.
2. SOLENOID VALVE & LIMIT SWITCHES WILL BE PROVIDED ONLY FOR CONTROL VALVES IF INDICATED IN RESPECTIVE DATA SHEETS.
3. SOLENOID VALVES PORTS CONDITION:
PORT 1 AND 2 SHALL BE CONNECTED UNDER DE-ENERGISED CONDITION.
PORT 2 AND 3 SHALL BE CONNECTED UNDER ENERGISED CONDITION.
4. PRESSURE GAUGES REQUIRED FOR AIR SUPPLY & OUTPUT(S).
5. MOUNTING ACCESSORIES AS REQUIRED.
6. POSITION FEEDBACK SIGNAL SHALL BE 2 WIRE 4-20mA ISOLATED SIGNAL.
7. JB TERMINALS SHALL BE CAGE CLAMP TYPE SUITABLE FOR 2.5 SQ. MM COPPER WIRE. EXTERNAL CONNECTION, OF PLUG IN TYPE OR THROUGH CABLE GLAND, SHALL BE AS PER DATA SHEET.
8. ALL APPLICABLE ACCESSORIES SHALL BE PROVIDED AS INDICATED IN THE INDIVIDUAL CONTROL VALVE DATA SHEET / ACCESSORIES DATA SHEET.
9. 12 METERS 1/4" PVC COATED COPPER / SS TUBING (AS PER ACCESSORIES DATA SHEET) & 1 SET OF FITTINGS TO BE SUPPLIED FOR EACH CONTROL VALVE FOR CONNECTION TO ISO VLV AT INST AIR HEADER ON ONE END AND TO AIR LOCK RELAY/AIR FILTER REGULATOR ON THE OTHER END. ALL THE BRASS / SS FITTINGS SHALL BE DOUBLE COMPRESSION TYPE.
10. VOLUME BOOSTER (ALONG WITH TEE-T3 AND RELATED TUBING & CONNECTORS) SHALL BE PROVIDED TO MEET STROKING TIME IF REQUIRED. AIR CONNECTION TO VOLUME BOOSTER FROM TEE-T3 AND POSITION SENSOR SHALL BE PROVIDED.



STANDARD

TITLE:-
CONTROL VALVE HOOK-UP DIAGRAM

DRG. No.	PES-145-06B		
REV. No.	0	DATE	08.12.14
SHEET	3	OF	7

STANDARD CONTROL VALVE HOOK-UP DIAGRAM (WITH SMART POSITIONER)

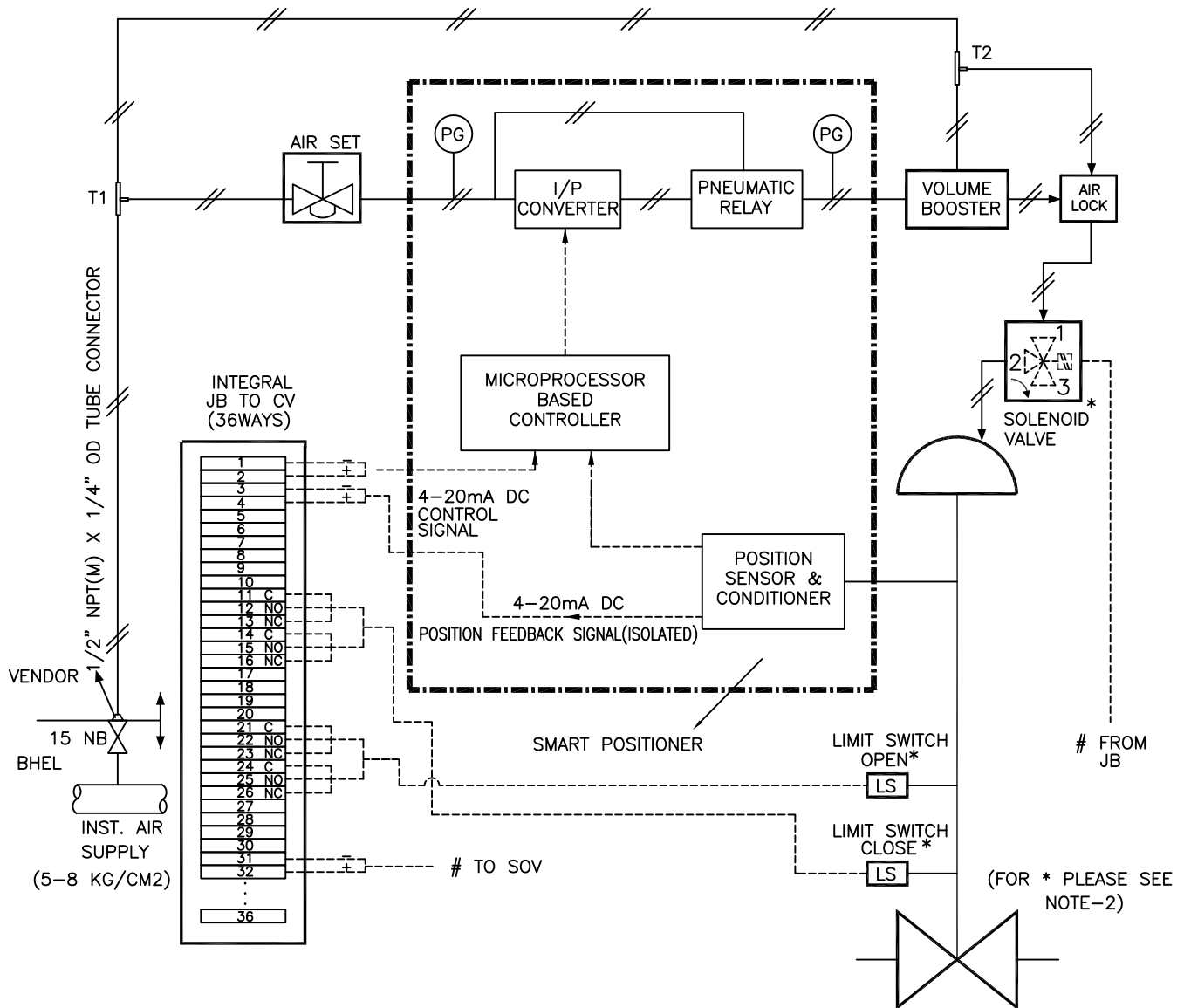

NOTES :-

1. POSITION OF EACH VALVE ON SUPPLY AIR FAILURE / ELECTRICAL SIGNAL FAILURE SHALL BE AS PER SPECIFICATION / DATA SHEET.
2. SOLENOID VALVE & LIMIT SWITCHES WILL BE PROVIDED ONLY FOR CONTROL VALVES IF INDICATED IN RESPECTIVE DATA SHEETS.
3. SOLENOID VALVES PORTS CONDITION:
PORT 1 AND 2 SHALL BE CONNECTED UNDER DE-ENERGISED CONDITION.
PORT 2 AND 3 SHALL BE CONNECTED UNDER ENERGISED CONDITION.
4. PRESSURE GAUGES REQUIRED FOR AIR SUPPLY & OUTPUT(S).
5. MOUNTING ACCESSORIES AS REQUIRED.
6. POSITION FEEDBACK SIGNAL SHALL BE 2 WIRE 4-20mA ISOLATED SIGNAL.
7. JB TERMINALS SHALL BE CAGE CLAMP TYPE SUITABLE FOR 2.5 SQ. MM COPPER WIRE. EXTERNAL CONNECTION, OF PLUG IN TYPE OR THROUGH CABLE GLAND, SHALL BE AS PER DATA SHEET
8. ALL APPLICABLE ACCESSORIES SHALL BE PROVIDED AS INDICATED IN THE INDIVIDUAL CONTROL VALVE DATA SHEET / ACCESSORIES DATA SHEET.
9. 12 METERS 1/4" PVC COATED COPPER / SS TUBING (AS PER ACCESSORIES DATA SHEET) & 1 SET OF FITTINGS TO BE SUPPLIED FOR EACH CONTROL VALVE FOR CONNECTION TO ISO VLV AT INST AIR HEADER ON ONE END AND TO AIR LOCK RELAY/AIR FILTER REGULATOR ON THE OTHER END. ALL THE BRASS / SS FITTINGS SHALL BE DOUBLE COMPRESSION TYPE.
10. VOLUME BOOSTER (ALONG WITH TEE-T2 AND RELATED TUBING & CONNECTORS) SHALL BE PROVIDED IF REQUIRED. AIR CONNECTION TO VOLUME BOOSTER FROM TEE-T2 SHALL BE PROVIDED.

	STANDARD	DRG. No.	PES-145-06B		
	TITLE:- CONTROL VALVE HOOK-UP DIAGRAM	REV. No.	0	DATE	08.12.14
		SHEET	4	OF	7

STANDARD CONTROL VALVE HOOK-UP DIAGRAM (FOR ON / OFF TYPE)

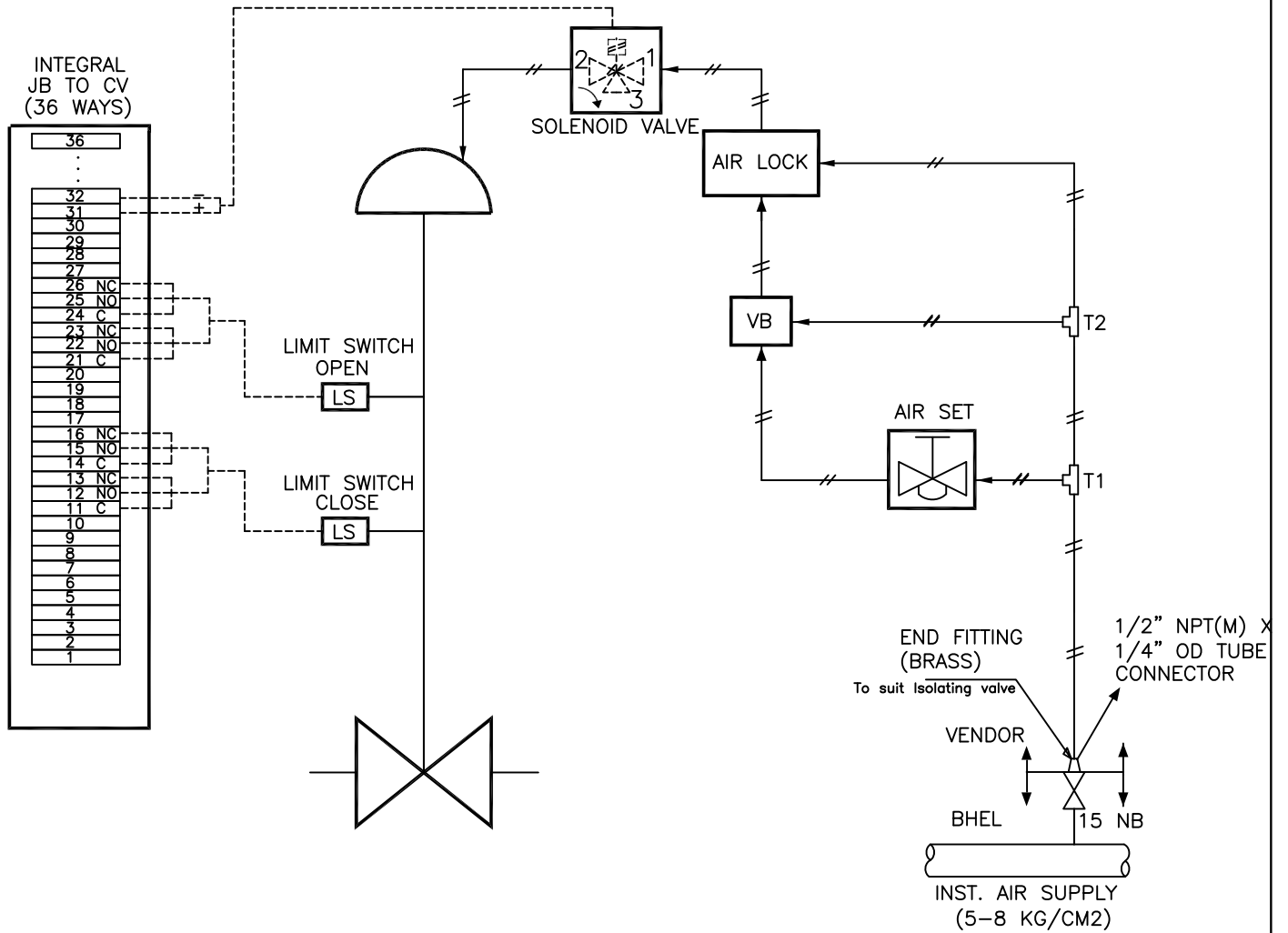

NOTES :-

1. POSITION OF EACH VALVE ON SUPPLY AIR FAILURE / ELECTRIC SIGNAL FAILURE SHALL BE AS PER SPECIFICATION / DATA SHEET.
2. SOLENOID VALVES PORTS CONDITION:
PORT 1 AND 2 SHALL BE CONNECTED UNDER DE-ENERGISED CONDITION.
PORT 2 AND 3 SHALL BE CONNECTED UNDER ENERGISED CONDITION.
3. MOUNTING ACCESSORIES AS REQUIRED.
4. JB TERMINALS SHALL BE CAGE CLAMP TYPE SUITABLE FOR 2.5 SQ. MM COPPER WIRE. EXTERNAL CONNECTION, OF PLUG IN TYPE OR THROUGH CABLE GLAND, SHALL BE AS PER DATA SHEET.
5. ALL APPLICABLE ACCESSORIES SHALL BE PROVIDED AS INDICATED IN THE INDIVIDUAL CONTROL VALVE DATA SHEET / ACCESSORIES DATA SHEET.
6. 12 METERS 1/4" PVC COATED COPPER / SS TUBING (AS PER ACCESSORIES DATA SHEET) & 1 SET OF FITTINGS TO BE SUPPLIED FOR EACH CONTROL VALVE FOR CONNECTION TO ISO VLV AT INST AIR HEADER ON ONE END AND TO AIR LOCK RELAY/AIR FILTER REGULATOR ON THE OTHER END. ALL THE BRASS / SS FITTINGS SHALL BE DOUBLE COMPRESSION TYPE.



STANDARD

TITLE:-

CONTROL VALVE HOOK-UP DIAGRAM

**DRG.
No.**

PES-145-06B

**REV.
No.**

0

DATE

08.12.14

SHEET

5

OF

7

STANDARD CONTROL VALVE HOOK-UP DIAGRAM (DOUBLE ACTING PISTON ACTUATOR WITH CONVENTIONAL POSITIONER)

Not Applicable

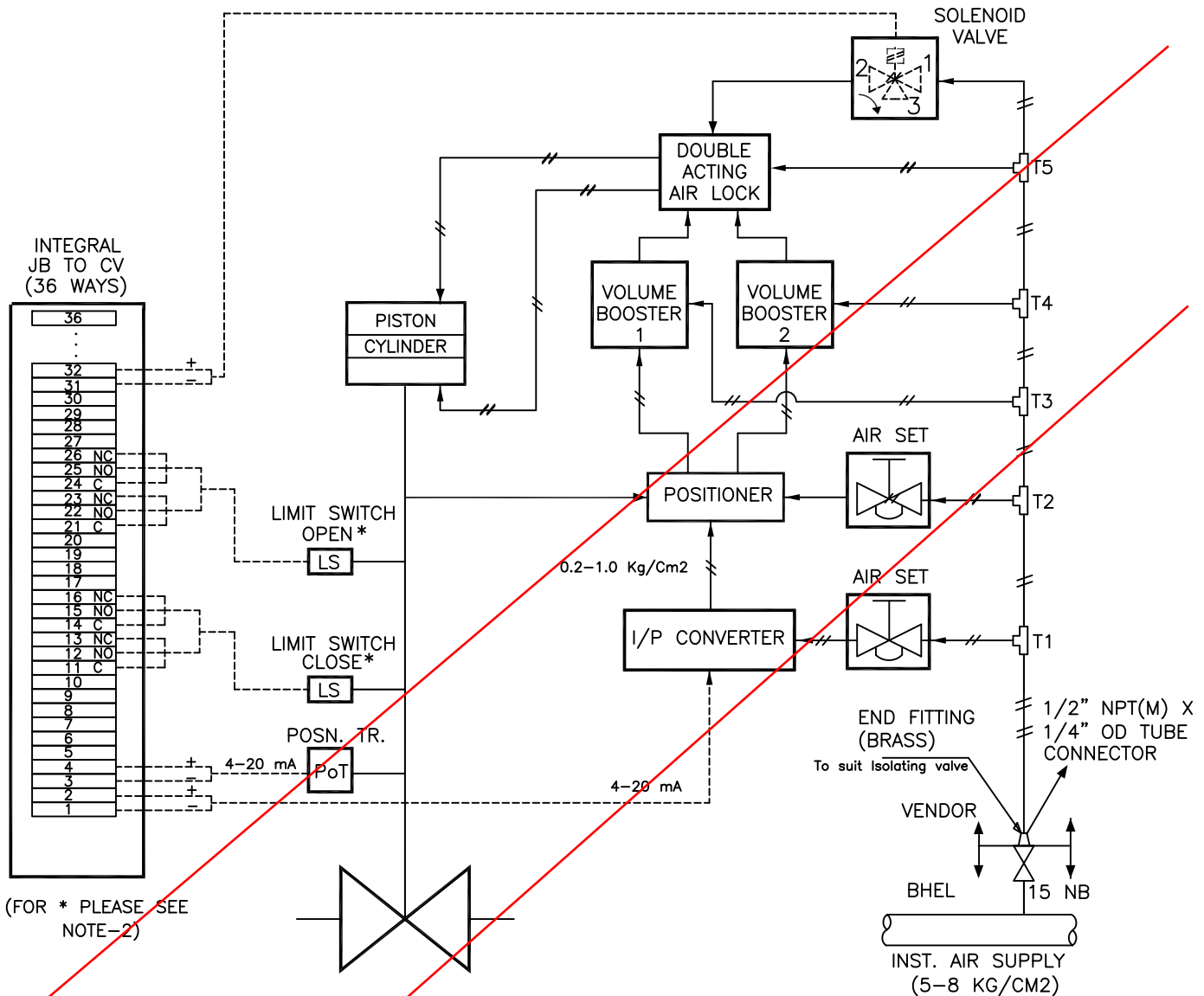

(FOR * PLEASE SEE NOTE-2)

NOTES :-

1. POSITION OF EACH VALVE ON SUPPLY AIR FAILURE / SIGNAL AIR FAILURE SHALL BE AS PER SPECIFICATION / DATA SHEET. AIR LOCK SHALL BE PROVIDED ACCORDINGLY.
2. SOLENOID VALVE & LIMIT SWITCHES WILL BE PROVIDED ONLY FOR CONTROL VALVES IF INDICATED IN RESPECTIVE DATA SHEETS.
3. SOLENOID VALVES PORTS CONDITION:
PORT 1 AND 2 SHALL BE CONNECTED UNDER DE-ENERGISED CONDITION.
PORT 2 AND 3 SHALL BE CONNECTED UNDER ENERGISED CONDITION.
4. PRESSURE GAUGES REQUIRED FOR AIR SUPPLY & OUTPUT(S).
5. MOUNTING ACCESSORIES AS REQUIRED.
6. POSITION FEEDBACK SIGNAL SHALL BE 2 WIRE 4-20ma ISOLATED SIGNAL.
7. JB TERMINALS SHALL BE CAGE CLAMP TYPE SUITABLE FOR 2.5 SQ. MM COPPER WIRE. EXTERNAL CONNECTION, OF PLUG IN TYPE OR THROUGH CABLE GLAND, SHALL BE AS PER DATA SHEET.
8. ALL APPLICABLE ACCESSORIES SHALL BE PROVIDED AS INDICATED IN THE INDIVIDUAL CONTROL VALVE DATA SHEET / ACCESSORIES DATA SHEET.
9. 12 METERS 1/4" PVC COATED COPPER / SS TUBING (AS PER ACCESSORIES DATA SHEET) & 1 SET OF FITTINGS TO BE SUPPLIED FOR EACH CONTROL VALVE FOR CONNECTION TO ISO VLV AT INST AIR HEADER ON ONE END AND TO AIR LOCK RELAY/AIR FILTER REGULATOR ON THE OTHER END. ALL THE BRASS / SS FITTINGS SHALL BE DOUBLE COMPRESSION TYPE.
10. VOLUME BOOSTER (ALONG WITH TEE-T3 AND RELATED TUBING & CONNECTORS) SHALL BE PROVIDED TO MEET STROKING TIME IF REQUIRED. AIR CONNECTION TO VOLUME BOOSTER FROM TEE-T3&T4 AND POSITION SENSOR SHALL BE PROVIDED.

	STANDARD		DRG. No. PES-145-06B	
	TITLE:- CONTROL VALVE HOOK-UP DIAGRAM		REV. No. 0	DATE 08.12.14
	SHEET 6		OF 7	

STANDARD CONTROL VALVE HOOK-UP DIAGRAM (DOUBLE ACTING PISTON ACTUATOR WITH SMART POSITIONER)

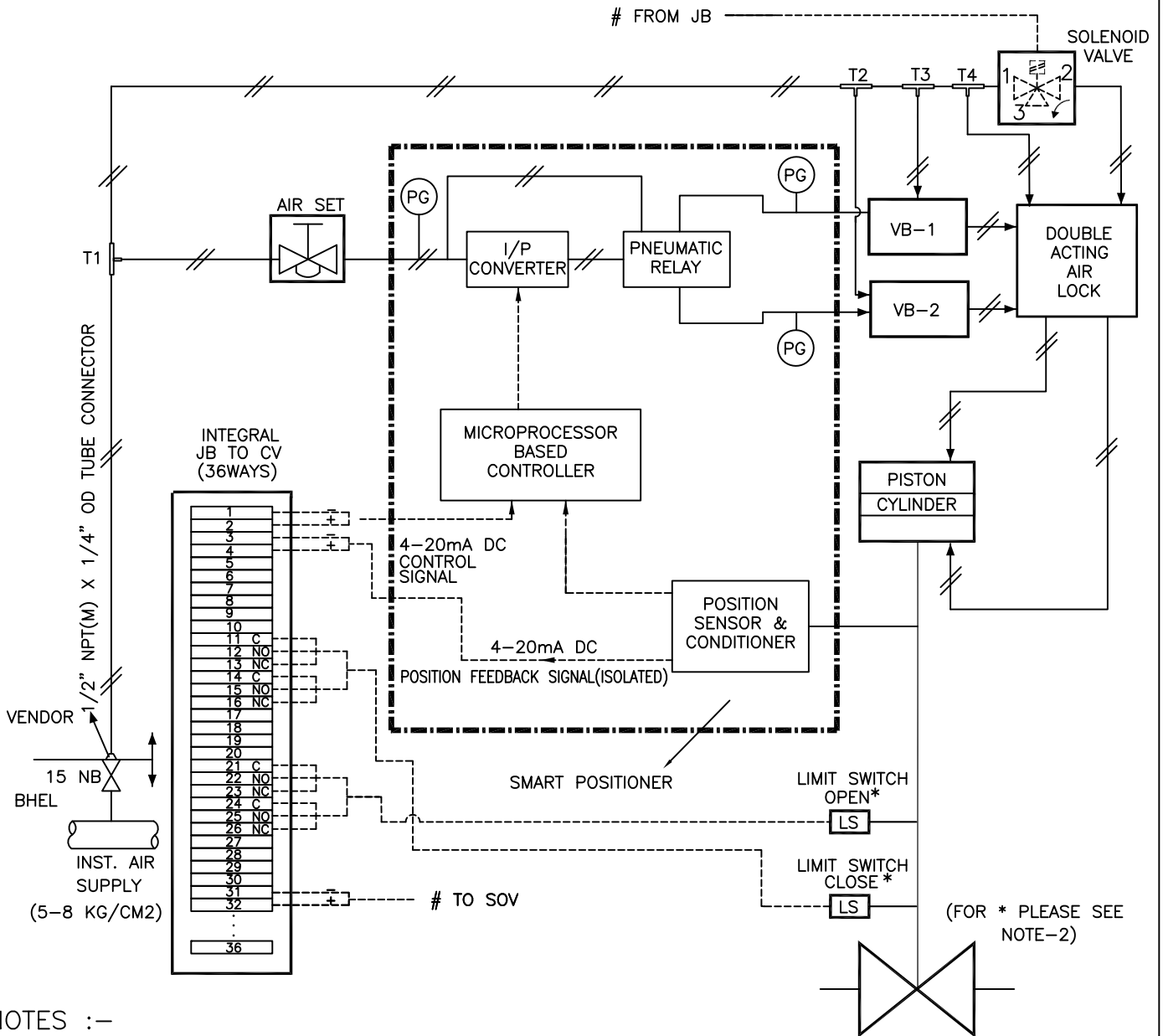

NOTES :-

1. POSITION OF EACH VALVE ON SUPPLY AIR FAILURE / ELECTRICAL SIGNAL FAILURE SHALL BE AS PER SPECIFICATION / DATA SHEET. AIR LOCK SHALL BE PROVIDED ACCORDINGLY.
2. SOLENOID VALVE & LIMIT SWITCHES WILL BE PROVIDED ONLY FOR CONTROL VALVES IF INDICATED IN RESPECTIVE DATA SHEETS.
3. SOLENOID VALVES PORTS CONDITION:
PORT 1 AND 2 SHALL BE CONNECTED UNDER DE-ENERGISED CONDITION.
PORT 2 AND 3 SHALL BE CONNECTED UNDER ENERGISED CONDITION.
4. PRESSURE GAUGES REQUIRED FOR AIR SUPPLY & OUTPUT(S).
5. MOUNTING ACCESSORIES AS REQUIRED.
6. POSITION FEEDBACK SIGNAL SHALL BE 2 WIRE 4-20mA ISOLATED SIGNAL.
7. JB TERMINALS SHALL BE CAGE CLAMP TYPE SUITABLE FOR 2.5 SQ. MM COPPER WIRE. EXTERNAL CONNECTION, OF PLUG IN TYPE OR THROUGH CABLE GLAND, SHALL BE AS PER DATA SHEET
8. ALL APPLICABLE ACCESSORIES SHALL BE PROVIDED AS INDICATED IN THE INDIVIDUAL CONTROL VALVE DATA SHEET / ACCESSORIES DATA SHEET.
9. 12 METERS 1/4" PVC COATED COPPER / SS TUBING (AS PER ACCESSORIES DATA SHEET) & 1 SET OF FITTINGS TO BE SUPPLIED FOR EACH CONTROL VALVE FOR CONNECTION TO ISO VLV AT INST AIR HEADER ON ONE END AND TO AIR LOCK RELAY/AIR FILTER REGULATOR ON THE OTHER END. ALL THE BRASS / SS FITTINGS SHALL BE DOUBLE COMPRESSION TYPE.
10. VOLUME BOOSTER (ALONG WITH TEE-T2 AND RELATED TUBING & CONNECTORS) SHALL BE PROVIDED IF REQUIRED. AIR CONNECTION TO VOLUME BOOSTER FROM TEE-T2 & TEE-T3 SHALL BE PROVIDED.



STANDARD

TITLE:-

CONTROL VALVE HOOK-UP DIAGRAM

DRG. No.	PES-145-06B		
REV. No.	0	DATE	08.12.14
SHEET	7	OF	7



Technical specification for
Control Valves with Accessories
(Pneumatically Operated)

4X270 MW MANUGURU

SPEC NO.: **PE-TS-411-145-I 801**

VOLUME II B

SECTION D

REV. NO. 00

DATE : 22.12.2014

SHEET OF

SECTION – D

DATA SHEET – C

BHEL PEM	DATA SHEET FOR CONTROL VALVES (WITH PNEUMATIC ACTUATOR)	SPECIFICATION NO.: PE-TS-411-145-I801		
		VOLUME	IIB	
		SECTION	D	
		REV. NO.	00	DATE : 22.12.2014
		SHEET	OF	

Tag No. :..... Qty.:

Date Sheet No. PES-145-06-DS1-0

DATA SHEET – C

DATA SHEET – A FOR CONTROL VALVE (WITH PNEUMATIC ACTUATOR) (TO BE FILLED BY CONTRACTOR AFTER AWARD OF CONTRACT)	DATA SHEET – B (TO BE FILLED UP BY BIDDER)
--	---

PERFORMANCE OF VALVE	LINEARITY HYSTERISIS SENSITIVITY ACCURACY (OVERALL)
----------------------	--	----------------------------------

SERVICE CONDITION*	SL. No. +	LOAD	FLOW (T/HR)	INLET PR. KG/CM2(A)	OUTLET PR. KG/CM2(A)	TEMP DEG (C)	CALC ULATED CV	% VLV LIFT	VLV O/L VELOCITY
VALVE TYPE									
* MAX SHUT OFF PRESS (KG/CM2g) * BODY DESIGN : PRESS (KG/CM2g) TEMP (DEG C) * IBR FORM III-C								

TOTAL WEIGHT (VALVE + ACTUATOR + ACCESSORIES) Kg
--	-------



Technical specification for
Control Valves with Accessories
(Pneumatically Operated)

4X270 MW MANUGURU

SPEC NO.: **PE-TS-411-145-I 801**

VOLUME II B

SECTION D

REV. NO. 00

DATE : 22.12.2014

SHEET OF

SECTION – D

QUALITY PLAN



STANDARD QUALITY PLAN FOR CONTROL VALVE (PNEUMATIC)

QUALITY PLAN NO.: PE-QP-999-145-I 006	
VOLUME	IIB
SECTION	D
REV. NO.	06
DATE:	05.09.2013
SHEET	1 OF 7

Sl. No.	Component / operation	Characteristics Checked	* Category	Type/Method of Check	Extent of Check	Reference documents	Acceptance Norms	Format of Records	Agency ^{\$}			Remarks
									P	W	V	
1.0 MATERIAL												
1.1	Body & Bonnet casting / forgings, plug, valve stem, seat ring/cage.	1. Physical, Chemical properties	MA	Physical, Chemical tests	One/ Heat(HT Batch)	Approved drg. / data sheet / BHEL specn.	Approved drg. / data sheet / BHEL specn.	Test Certificate	3	---	2,1	
		2. Heat Treatment	MA	Review of H.T. Chart	Each H.T.	Approved drg. / data sheet / BHEL specn.	Approved drg. / data sheet / BHEL specn.	Test Certificate	3/2	2	1	IBR Certification (if applicable) to be verified by BHEL
		3. Internal quality of castings	MA	RT for Body & UT for Bonnet(NDT)	100%	ASME B 16.34	ASME B 16.34	Test Report / FILM	3/2	2	1	Only for rating ANSI 900 and above. Applicable for Body and Bonnet only. For Lower rating only if called for in specification.
		4. Surface Quality	MA	1. Visual	100%	MSS-SP-55	MSS-SP-55	Test Certificate	3/2	---	2,1	
2. MT/PT	100%			ASME B 16.34	ASME B 16.34	Test Certificate	3	2	1	After Machining on machined surface only		

LEGEND: * CR - Critical characteristics
MA - Major characteristics
MI - Minor characteristics

RT- Radiographic Test
UT - Ultrasonic Test

PT - Dye penetrant Test
MT- Magnetic Test

^{\$} P - Agency Performing the Test.
W - Agency Witnessing the Test.
V - Agency Verifying the Test.

1 - BHEL
2 - Vendor
3 - Sub-vendor



STANDARD QUALITY PLAN FOR CONTROL VALVE (PNEUMATIC)

QUALITY PLAN NO.: **PE-QP-999-145-I 006**

VOLUME IIB

SECTION D

REV. NO. 06 DATE: 05.09.2013

SHEET 2 OF 7

Sl. No.	Component / operation	Characteristics Checked	* Category	Type/Method of Check	Extent of Check	Reference documents	Acceptance Norms	Format of Records	Agency [§]			Remarks
									P	W	V	
		5. Pressure test for shell	MA	Hyd. Test	100%	ISA-S-75.19/ ASME B 16.34	ISA-S-75.19/ ASME B 16.34	Test Certificate	2	2	1	For Body & Bonnet after machining
1.2	Diaphragm	1. Surface Quality	MA	Visual	100%	Mfr. standard	Mfr. standard	Test Certificate	3/2	---	2,1	
		2. Hardness	MA	Measurement	100%	Mfr. standard	Mfr. standard	Test Certificate	3/2	---	2,1	
		3. Endurance / Life cycle	MA	Cyclic test 10,000 cycles	One / Type	10,000 cycles/ Mfr. standard.	No damage	Test Certificate	3/2		2,1	
1.3	Spring	1. Composition	MA	Chemical- Analysis	One sample/ Heat	Material spec. / Mfr. standard	Material spec. / Mfr. standard	Test Certificate	3	---	2,1	
		2. Mech. Properties	MA	Mech. Test	One sample/ Heat	Material spec. / Mfr. standard	Material spec. / Mfr. standard	Test Certificate	3	---	2,1	
		3. Performance	MA	1. Stiffness ratio	100%	Material spec. / Mfr. standard	Material spec. / Mfr. standard	Test Certificate	3	---	2,1	
				2. Scragging	100%	Material spec. / Mfr. standard	Material spec. / Mfr. standard	Test Certificate	3	---	2,1	
				3. Cyclic test (Endurance)	One / type	10,000 cycles	Material spec. / Mfr. standard	Test Certificate	3	---	2,1	
				4. Dimension (Measurement)	One sample/ Lot	Mfr. standard	Appd Drg	Record	3	---	2,1	

LEGEND: * CR - Critical characteristics
MA - Major characteristics
MI - Minor characteristics

RT- Radiographic Test
UT - Ultrasonic Test

PT - Dye penetrant Test
MT- Magnetic Test

[§] P - Agency Performing the Test.
W - Agency Witnessing the Test.
V - Agency Verifying the Test.

1 - BHEL
2 - Vendor
3 - Sub-vendor



STANDARD QUALITY PLAN FOR CONTROL VALVE (PNEUMATIC)

QUALITY PLAN NO.: **PE-QP-999-145-I 006**

VOLUME IIB

SECTION D

REV. NO. 06 DATE: 05.09.2013

SHEET 3 OF 7

Sl. No.	Component / operation	Characteristics Checked	* Category	Type/Method of Check	Extent of Check	Reference documents	Acceptance Norms	Format of Records	Agency ^{\$}			Remarks
									P	W	V	
1.4	Electrical items [Limit switches, Solenoids, Position Transmitter(if provided externally)]	1. Routine Test	MA	HV, IR, Continuity function	100%	Rele. Standards	Rele. Standards	Test Certificate	3	---	2,1	In case TC is not available, Actual test shall be conducted
		2. Degree of protection	MA	IP/NEMA Tests	One sample / type	Approved Data sheet	Approved Data sheet	Test Certificate	3	---	2,1	
1.5	Pressure Gauges	1. Performance	MA	Review of calibration certificates	100%	Mfr. Standard	Mfr. Standard	Test Certificate	3	---	2,1	
		2. Marking	MA	Visual	100%	Mfr. standard	Mfr. standard	Records	3	---	2,1	
2.0	IN PROCESS INSPECTION											
2.1	After machining, i, Body ii Bonnet iii Plug iv Valve Stem v seat ring/cage	1. Surface flaws	MA	Visual & MT/PT	100% (on accessible surfaces)	ASME B 16.34	ASME B 16.34	Test Records	2	---	1	Butt weld ends shall be included.
		2. Dimensional checks	MA	Measurement	100%	Mfr. Standard	Mfr. Standard	Records	2	---	1	
		3. Hard facing (wherever applicable)	MA	Hardness Measurement	One sample/Lot	Mfr. Standard	Mfr. Standard	Records	2	---	1	
2.2	Lapping	Machining surface contact	MA	Blue Matching	One sample/lot	-----	Proper Physical Contact	---	2	---	---	
3.0	TESTS ON COMPLETED VALVE											
<p>LEGEND: * CR - Critical characteristics RT- Radiographic Test PT – Dye penetrant Test ^{\$} P - Agency Performing the Test. 1 - BHEL MA - Major characteristics UT – Ultrasonic Test MT- Magnetic Test W - Agency Witnessing the Test. 2 - Vendor MI - Minor characteristics V - Agency Verifying the Test. 3 - Sub-vendor</p>												



STANDARD QUALITY PLAN FOR CONTROL VALVE (PNEUMATIC)

QUALITY PLAN NO.: **PE-QP-999-145-I 006**

VOLUME IIB

SECTION D

REV. NO. 06 DATE: 05.09.2013

SHEET 4 OF 7

Sl. No.	Component / operation	Characteristics Checked	* Category	Type/Method of Check	Extent of Check	Reference documents	Acceptance Norms	Format of Records	Agency ^{\$}			Remarks
									P	W	V	
3.1	Actuator Chamber	Leakage & Strength	MA	Pneumatic test	100%	Mfr. Standard	No Leakage	Test Certificate	2	1	1	Refer Note-4
3.2	Body	Leakage and Pressure test (Body Mount Leakage)	MA	Hydro test	100%	ISA - S-75.19	No Leakage	Test Certificate	2	1	1	Refer Note-4
3.3	Seat leakage test for completed valve	Seat Leakage	MA	Pneumatic Test	100%	FCI-70.2	FCI-70.2	Test Certificate	2	1	1	Refer Note-4
4.0	OPERATION TEST ON COMPLETED VALVE (Final inspection)	1. Valve Travel	MA	Measurement	100%	Approved drg. / data sheet	Approved drg. / data sheet	Test Report	2	1	1	Refer Note-4
		2. Opening/Closing time	MA	Measurement	100%	Approved drg. / data sheet	Approved drg. / data sheet	Test Report	2	1	1	Refer Note-4
		3. Linearity/cam characteristic	MA	Measurement	100%	Approved drg. / data sheet	Approved drg. / data sheet	Test Report	2	1	1	Refer Note-4
		4. Repeatability	MA	Measurement	100%	Approved drg. / data sheet	Approved drg. / data sheet	Test Report	2	1	1	Refer Note-4
		5. Hysteresis	MA	Measurement	100%	Approved drg. / data sheet	Approved drg. / data sheet	Test Report	2	1	1	Refer Note-4
		6. Sensitivity	MA	Measurement	100%	Approved drg. / data sheet	Approved drg. / data sheet	Test Report	2	1	1	Refer Note-4
		7. Accuracy (Overall)	MA	Measurement	100%	Approved drg. / data sheet	Approved drg. / data sheet	Test Report	2	1	1	Refer Note-4
		8. Control Valve characteristics / CV Test	MA	◆ Measurement (Press. vs. discharge and discharge vs. opening 0-100% in steps of 10%)	One per type	As per specs/ Approved drg. / data sheet	As per specs/ Approved drg. / data sheet	Test Certificate	2	--	1	◆ Size = Body & port size Or Body size & CV for non std port. Refer Note 1.

LEGEND: * CR - Critical characteristics
MA - Major characteristics
MI - Minor characteristics

RT- Radiographic Test
UT - Ultrasonic Test

PT - Dye penetrant Test
MT- Magnetic Test

^{\$} P - Agency Performing the Test.
W - Agency Witnessing the Test.
V - Agency Verifying the Test.

1 - BHEL
2 - Vendor
3 - Sub-vendor



STANDARD QUALITY PLAN FOR CONTROL VALVE (PNEUMATIC)

QUALITY PLAN NO.: PE-QP-999-145-I 006	
VOLUME	IIB
SECTION	D
REV. NO.	06
DATE:	05.09.2013
SHEET	5 OF 7

Sl. No.	Component / operation	Characteristics Checked	* Category	Type/Method of Check	Extent of Check	Reference documents	Acceptance Norms	Format of Records	Agency ^{\$}			Remarks
									P	W	V	
		9. Operation of limit switch & solenoids and other accessories	MA	Function	100%	Approved drg. / data sheet	As per specs/ Approved drg. / data sheet	Test Report	2	1	1	On assembled valve Refer Note-4
		10. Overall dimensions	MI	Visual and dimensional	100%	Approved drg. / data sheet	As per specs/ Approved drg. / data sheet	Records	2	1	1	Refer Note-4
		11. Pre defined valve position in case of air failure	MA	Visual	100%	As per spec & Appd drg	As per spec & Appd drg	Test Certificate	2	1	1	
		12. Cleanliness, painting, stamping (for direction of flow), Tag No.	MA	Visual and dimensional	100%	Approved drg. / data sheet	As per specs/ Approved drg. / data sheet	Test Certificate	2	1	1	
5.0	AUXILIARY ITEMS (Performance test of auxiliary items shall be performed on the completely assembled valve)											
5.1	Positioner	Overall leakage after assembly including Nozzles leakage	MA	Leak Test (in the steady state input signal)	100 %	Mfr. Standard	No leakage	Test Certificate	3/2	---	1	Overall leakage including tubing
5.2	Air filter regulator	1. Normal air consumption	MA	Measurement	Each type	Mfr. Standard	No leakage	Test Certificate	3/2	---	1	
		2. Overall leakage	MA	Visual (soap solution)	100 %	Mfr. Standard	No leakage	Test Certificate	3/2	---	1	
5.3	Air lock relay	Performance Test	MA	Leakage test	100%	Mfr. Standard	No leakage	Test Certificate	3/2	---	1	
5.4	Electronic position transmitter(not applicable if provided integral to smart positioner)	1. Accuracy	MA	Operation	100%	Approved data sheet /	Approved data sheet /	Test Certificate	2	1	1	

LEGEND: * CR - Critical characteristics
MA - Major characteristics
MI - Minor characteristics

RT- Radiographic Test
UT - Ultrasonic Test

PT - Dye penetrant Test
MT- Magnetic Test

^{\$} P - Agency Performing the Test.
W - Agency Witnessing the Test.
V - Agency Verifying the Test.

1 - BHEL
2 - Vendor
3 - Sub-vendor



STANDARD QUALITY PLAN FOR CONTROL VALVE (PNEUMATIC)

QUALITY PLAN NO.: PE-QP-999-145-I 006	
VOLUME	IIB
SECTION	D
REV. NO.	06
DATE:	05.09.2013
SHEET	6 OF 7

Sl. No.	Component / operation	Characteristics Checked	* Category	Type/Method of Check	Extent of Check	Reference documents	Acceptance Norms	Format of Records	Agency ^{\$}			Remarks
									P	W	V	
5.5	Current to Pneumatic converter(not applicable for smart positioner)	1. Physical Verification Make/Model	MA	Visual	100%	Approved drg. / data sheet	Approved drg. / data sheet	Test Certificate	2	---	2,1	
		2. Degree of Protection	MA	IP/NEMA test	Each type	Relevant Standard	Relevant Standard	Test Certificate	3	---	2,1	
		3. Linearity	CR	Measurement	100%	Approved drg. / data sheet / BHEL specn.	Approved drg. / data sheet / BHEL specn.	Inspection Report	2	---	1	
		4. Hysterisis	CR	Measurement	100%	Approved drg. / data sheet / BHEL specn.	Approved drg. / data sheet / BHEL specn.	Inspection Report	2	---	1	
5.6	Smart Positioner (As Applicable)	1. Physical Verification Make/Model	MA	Visual	100%	Approved drg. / data sheet	Approved drg. / data sheet	Test Certificate	2	---	2,1	
		2. Degree of Protection	MA	IP/NEMA test	Each type	Relevant Standard	Relevant Standard	Test Certificate	3	---	2,1	
		3. Linearity	CR	Measurement	100%	Approved drg. / data sheet / BHEL specn.	Approved drg. / data sheet / BHEL specn.	Inspection Report	2	---	1	
		4. Hysterisis	CR	Measurement	100%	Approved drg. / data sheet / BHEL specn.	Approved drg. / data sheet / BHEL specn.	Inspection Report	2	---	1	
		5. Calibration with Hand Held Communicator	MA	Measurement	Each type	Approved data sheet / Mfr. Standard	Approved data sheet / Mfr. Standard	Test Certificate	2	1	1	
6.0	PAINTING	Soundness of Painting	MA	Visual and Measurement	100%	BHEL specn. / Mfr. Standard	BHEL specn. / Mfr. Standard	Inspection Report	2	---	---	Refer Note-2
7.0	PACKING	Soundness of Packing against transit damage	MA	Visual	100%	Mfr. Standard	Mfr. Standard	Inspection Report	2	---	---	Refer Note-3

LEGEND: * CR - Critical characteristics
 MA - Major characteristics
 MI - Minor characteristics

RT- Radiographic Test
 UT - Ultrasonic Test

PT - Dye penetrant Test
 MT- Magnetic Test

^{\$} P - Agency Performing the Test.
 W - Agency Witnessing the Test.
 V - Agency Verifying the Test.

1 - BHEL
 2 - Vendor
 3 - Sub-vendor

 PEM :: C&I	STANDARD QUALITY PLAN FOR CONTROL VALVE (PNEUMATIC)						QUALITY PLAN NO.: PE-QP-999-145-I 006					
							VOLUME		IIB			
							SECTION		D			
							REV. NO.		06		DATE: 05.09.2013	
							SHEET		7		OF 7	
Sl. No.	Component / operation	Characteristics Checked	* Category	Type/Method of Check	Extent of Check	Reference documents	Acceptance Norms	Format of Records	Agency ^{\$}			Remarks
									P	W	V	

NOTES:

1. In case valid CV test certificate for a similar control valve(Same type, Same size, Same CV) is not submitted to BHEL by the vendor, CV test shall be conducted at FCRI/Any govt. approved laboratory/ BHEL approved Laboratory.
2. In the absence of BHEL spec. for painting, vendor to obtain BHEL's approval on their painting specification / procedure.
3. Sea worthy packing shall be provided, if applicable.
4. The quantum of check shall be 100% for manufacturer and 10% for BHEL/BHEL nominated inspection agency.
5. IBR certificates in Form III-C shall be submitted if called for in the specification/datasheet.
6. Copies of all TC's(Test Certificates) for materials duly correlated with Heat Nos., TC's for electrical items and mechanical tests(Leak/Operation) shall be submitted to BHEL for verification and acceptance.

LEGEND:	* CR - Critical characteristics MA - Major characteristics MI - Minor characteristics	RT- Radiographic Test UT – Ultrasonic Test	PT – Dye penetrant Test MT- Magnetic Test	^{\$} P - Agency Performing the Test. W - Agency Witnessing the Test. V - Agency Verifying the Test.	1 - BHEL 2 - Vendor 3 - Sub-vendor
----------------	---	---	--	--	--



Technical specification for
Control Valves with Accessories
(Pneumatically Operated)

4X270 MW MANUGURU

SPEC NO.: **PE-TS-411-145-I 801**

VOLUME II B

SECTION D

REV. NO. 00

DATE : 22.12.2014

SHEET OF

SECTION – D

BILL OF QUANTITY

	Technical specification for Control Valves with Accessories (Pneumatically Operated) 4x270 MW MANUGURU	SPEC NO.: PE-TS-411-145-I 801	
		VOLUME II B	
		SECTION D	
		REV. NO. 00	DATE : 22.12.2014
		SHEET	

BILL OF QUANTITY

S.NO	ITEM DESCRIPTION		Qty/Unit	Qty for four Units
[A] CONTROL VALVES COMPLETE WITH PNEUMATIC ACTUATOR AND ALL ACCESSORIES MOUNTED , PIPED AND TERMINATED ON JB				
S. No.	TAG NO.	SERVICE		
1	AS-2	DEAERATOR PEGGING FROM AS HEADER	1	4
2	CD-14	DEAERATOR LEVEL CONTROL	1	4
3	CD-21	EXCESS RETURN TO CST	1	4
4	CD-25	CEP MINIMUM RECIRCULATION	1	4
5	CD-76	CONDENSATE FOR VALVE GLAND SEALING	1	4
6	CRH-2	DEAERATOR PEGGING FROM CRH	1	4
7	DR-2	HPH-6 NORMAL DRAIN TO HPH-5	1	4
8	DR-9	HPH-6 ALT DRAIN TO HP FLASH TANK	1	4
9	DR-13	HPH-5 DRAIN TO DEAERATOR	1	4
10	DR-16	HPH-5 ALT DRAIN TO HP FLASH TANK	1	4
11	DR-19	LPH-3 NORMAL DRAIN TO LPH-2	1	4
12	DR-22	LPH-3 ALT DRAIN TO LP FLASH TANK	1	4
13	DR-25	LPH-2 NORMAL DRAIN TO LPH-1	1	4
14	DR-28	LPH-2 ALT DRAIN TO LP FLASH TANK	1	4
15	DR-38	DEAERATOR OVERFLOW TO LP F/TANK	1	4
16	FD-14	FEED CONTROL VALVE(100% CAPACITY)	1	4
17	FD-17	FEED CONTROL VALVE(100% CAPACITY)	1	4
18	FD-20	FEED CONTROL VALVE (30% CAPACITY)	1	4
19	DM-15	EMERGENCY MUP TO CONDENSER	1	4
20	DM-20	NORMAL MUP TO CONDENSER	1	4

	Technical specification for Control Valves with Accessories (Pneumatically Operated) 4x270 MW MANUGURU	SPEC NO.: PE-TS-411-145-I 801	
		VOLUME II B	
		SECTION D	
		REV. NO. 00	DATE : 22.12.2014
		SHEET	

S.NO	ITEM DESCRIPTION	Qty/Unit	Qty for four Units	
[B]	15 Meters of 10mm OD x 1.5mm thick Cu. Tubing (for each CV) (To be supplied Loose)	300 meter	1200 meter	
[C]	FITTINGS: for each CV (To be Supplied Loose)	(i) BRASS FITTING-Double Compression Type for Connection to 2 nos. Air Filter Regulators	1 LOT	4 LOT
		(ii) BRASS FITTING- Double Compression Type for Connection to Solenoid Valve	1 LOT	4 LOT
		(iii) BRASS FITTING- Double Compression Type for Connection to IA Header isolation valve.	1 LOT	4 LOT
		(iv) Brass TEE	1 LOT	4 LOT
[D]	START-UP/COMMISSIONING SPARES : (TOTAL PRICE FOR 1 SETS OF BODY AND BONNET GASKET & 1 SETS OF GLAND PACKINGS PER CV	1 LOT	4 LOT	
[E]	DIAGNOSTIC SOFTWARE	1 LOT	4 LOT	
[F]	UNIVERSAL HAND HELD CALIBRATOR	1 NOS.	4 NOS.	
[G]	INDUSTRIAL PC	1 NOS.	4 NOS.	



Technical specification for
Control Valves with Accessories
(Pneumatically Operated)

4x270 MW MANUGURU

SPEC NO.: **PE-TS-411-145-I 801**

VOLUME II B

SECTION D

REV. NO. 00

DATE : 22.12.2014

SHEET OF

SECTION – D

SPARES

	Technical specification for Control Valves with Accessories (Pneumatically Operated)		SPEC NO.: PE-TS-411-145-I 801	
			VOLUME	II B
			SECTION	D
	REV. NO.	00	DATE	: 22.12.2014
			SHEET	OF

[A] LIST OF MANDATORY SPARES

Mandatory Spares for Control Valve (Except FD-14, FD-17 and FD-20)

S.NO.	ITEM DESCRIPTION	QUANTITY	CALCULATED QUANTITY
1	Actuator Diaphragm	1 no.for each valve	68 Number
2	Feedback Linkage	1 no.for each valve	68 nos.
3	Smart Positioners	10% of total quantity of each model/type	7 nos single acting
4	Complete Consumables for Valve Viz. O-ring, Gland Packing, Packing Ring, Bonnet Seal etc	2 Sets each size, rating, type	136 Sets
5	Valve Seat	2 Sets each size, rating, type	136 Sets
6	Actuator Piston with Rod & Seal	2 Sets each size, rating, type	
7	Valve trim (including cage, plug, stem, seat rings, guide bushings etc.) for each of the control valves as offered.	1 set for each size, rating, type	17 TYPES
8	Solenoid valves		7 nos.
9	Limit Switches		7 nos.

Mandatory Spares for Control Valve FD-14, FD-17 and FD-20

S.NO.	ITEM DESCRIPTION	QUANTITY	CALCULATED QUANTITY
1	Actuator Diaphragm	1 no.for each valve	4 Number
2	Feedback Linkage	1 no.for each valve	12 nos.
3	Smart Positioners	10% of total quantity of each model/type	2 nos.
4	Complete Consumables for Valve Viz. O-ring, Gland Packing, Packing Ring, Bonnet Seal etc	2 Sets each size, rating, type	24 Sets
5	Valve Seat	2 Sets each size, rating, type	24 Sets
6	Actuator Piston with Rod & Seal	2 Sets each size, rating, type	
7	Valve trim (including cage, plug, stem, seat rings, guide bushings etc.) for each of the control valves as offered.	1 set for each size, rating, type	2 Types
8	Solenoid valves		1 nos.
9	Limit Switches		1 nos.
10	Bonnet	50% of total quantity used	2 No (FD-20) & 4 No (FD-14, FD17)



Technical specification for
Control Valves with Accessories
(Pneumatically Operated)

4X270 MW MANUGURU

SPEC NO.: PE-TS-411-145-I 801

VOLUME II B

SECTION D

REV. NO. 00

DATE : 22.12.2014

SHEET OF

[B] LIST OF COMMISSIONING SPARES

Sr .No.	ITEM DESCRIPTION	QUANTITY REQUIRED
1	Gaskets	One (1) set with each control valve Tag
2	Gland Packing	One (1) set with each control valve Tag

- NOTES:** - 1.The quantities for FOUR units shall be four the quantities for one unit.
2. The Actual Quantity shall be worked out during detailed Engineering.

Telangana State Power Generation Corporation Limited
4x270 MW MANUGURU

TECHNICAL SPECIFICATION
FOR
CONTROL VALVES WITH ACCESSORIES
(Pneumatically Operated)

VOLUME III

SPECIFICATION No: **PE-TS-411-145-I 801**



BHARAT HEAVY ELECTRICALS LIMITED
POWER SECTOR
PROJECT ENGINEERING MANAGEMENT DIVISION
NOIDA, INDIA

	Technical specification for Control Valves with Accessories (Pneumatically Operated) 4X270 MW MANUGURU	SPEC NO.: PE-TS-411-145-I 801	
		VOLUME III	
		SECTION	
		REV. NO. 00	DATE : 22.12.2014
		SHEET OF	

CONTENTS

VOL-III

S. No.	DESCRIPTION	No. of sheets
1	COMPLIANCE CERTIFICATE	1
2	SCHEDULE OF PRICES	1
3	SCHEDULE OF UNIT PRICES	1
4	CV TEST CHARGES	1
5	INSPECTION SCHEDULE	1
6	SCHEDULE OF SUBMISSION OF DRAWINGS/DOCUMENTS	1

COMPLIANCE CERTIFICATE
For
Control Valve with accessories
(To be Signed & Stamped by the Bidder)

Project: 4X270 MW MANUGURU

Specification no.: PE-TS-411-145-1801

We shall comply with the following:-

1. All the requirements as stated in Technical Specification / Specific Technical requirement / Data sheets / Drawings, BHEL quality plan etc as enclosed in the tender, shall be fully complied **without any deviation**.
2. BHEL Quality Plan (enclosed with the specification) duly signed and stamped is submitted herewith **without any deviation**.
3. Calculation of Cv, Noise level, Valve outlet velocity, Trim exit velocity, Actuator sizing, Data sheet-C in line with Data sheet-A of specification, dimensional drawings / edge preparation details, etc shall be submitted for BHEL/Customer review and approval, to reach BHEL within 15 days after receipt of LOI.
4. Selection of valves and Actuators are our (bidder's) responsibility. Any change in selection of type of valve and Actuators / Sizing / percentage opening, calculations, QP, etc., if desired by BHEL / Customer during approval of the documents after award of contract, without major changes in process parameters as per tender Specification, shall be carried out without any commercial implication and time delay.
5. Body material and Trim material combinations offered will be equivalent or better than the material specified in data sheet-A. Wherever Trim material combinations offered differ from the specification, its superiority shall be authenticated with documentary evidence and justification produced for BHEL / Customer's concurrence. BHEL / Customer reserves the right to accept/rejects any variation to the specification.

Signature with date	
Name	
Company seal	

	Technical specification for Control Valves with Accessories (Pneumatically Operated) 4X270 MW MANUGURU	SPEC NO.: PE-TS-411-145-I 801	
		VOLUME II B	
		SECTION D	
		REV. NO. 00	DATE : 22.12.2014
		SHEET	

SCHEDULE OF PRICES

S.NO	ITEM DESCRIPTION		Qty/Unit	Qty for FOUR Units	PRICE FOR ONE UNIT(Ex Works)	PRICE FOR FOUR UNITS(Ex Works)
S. No.[A]	TAG NO.	SERVICE				
1	AS-2	DEAERATOR PEGGING FROM AS HEADER	1	4		
2	CD-14	DEAERATOR LEVEL CONTROL	1	4		
3	CD-21	EXCESS RETURN TO CST	1	4		
4	CD-25	CEP MINIMUM RECIRCULATION	1	4		
5	CD-76	CONDENSATE FOR VALVE GLAND SEALING	1	4		
6	CRH-2	DEAERATOR PEGGING FROM CRH	1	4		
7	DR-2	HPH-6 NORMAL DRAIN TO HPH-5	1	4		
8	DR-9	HPH-6 ALT DRAIN TO HP FLASH TANK	1	4		
9	DR-13	HPH-5 DRAIN TO DEAERATOR	1	4		
10	DR-16	HPH-5 ALT DRAIN TO HP FLASH TANK	1	4		
11	DR-19	LPH-3 NORMAL DRAIN TO LPH-2	1	4		
12	DR-22	LPH-3 ALT DRAIN TO LP FLASH TANK	1	4		
13	DR-25	LPH-2 NORMAL DRAIN TO LPH-1	1	4		
14	DR-28	LPH-2 ALT DRAIN TO LP FLASH TANK	1	4		
15	DR-38	DEAERATOR OVERFLOW TO LP F/TANK	1	4		
16	FD-14	FEED CONTROL VALVE(100% CAPACITY)	1	4		
17	FD-17	FEED CONTROL VALVE(100% CAPACITY)	1	4		
18	FD-20	FEED CONTROL VALVE (30% CAPACITY)	1	4		
19	DM-15	EMERGENCY MUP TO CONDENSER	1	4		
20	DM-20	NORMAL MUP TO CONDENSER	1	4		

PARTICULARS OF THE BIDDER / AUTHORISED REPRESENTATIVE

NAME	DESIGNATION	SIGNATURE	DATE	COMPANY SEAL

	Technical specification for Control Valves with Accessories (Pneumatically Operated)		SPEC NO.: PE-TS-411-145-I 801	
			VOLUME	II B
			SECTION	D
	REV. NO.	00	DATE	: 22.12.2014
			SHEET	
4X270 MW MANUGURU				

S.NO	ITEM DESCRIPTION	Qty/Unit	Qty for FOUR Units	PRICE FOR ONE UNIT(Ex Works)	PRICE FOR FOUR UNITS(Ex Works)	
[B]	15 Meters of 10mm OD x 1.5mm thick SS. Tubing (for each CV) (To be supplied Loose)	300 meter	1200 meter			
[C]	FITTINGS: for each CV (To be Supplied Loose)	(i) BRASS FITTING-Double Compression Type for Connection to 2 nos. Air Filter Regulators	1 LOT	4 LOT		
		(ii) BRASS FITTING- Double Compression Type for Connection to Solenoid Valve	1 LOT	4 LOT		
		(iii) BRASS FITTING- Double Compression Type for Connection to IA Header isolation valve.	1 LOT	4 LOT		
		(iv) Brass TEE	1 LOT	4 LOT		
		(v) SS CONNECTOR FOR CONNECTION BETWEEN TUBING & IA HDR ISOLATION VLV PER CV	1 LOT	4 LOT		
[D]	MANDATORY SPARES	1 LOT	1 LOT			
[E]	START-UP/COMMISSIONING SPARES : (TOTAL PRICE FOR 1 SETS OF BODY AND BONNET GASKET & 1 SETS OF GLAND PACKINGS PER CV)	1 LOT	4 LOT			
[F]	TOTAL Cv TEST CHARGE	1 LOT	1 LOT			
[G]	DIAGNOSTIC SOFTWARE	1 LOT	4 LOT			
[H]	INDUSTRIAL PC	1 Nos.	4 Nos.			
[I]	UNIVERSAL HAND HELD CALIBRATOR	1 NOS.	4 NOS.			
[J]	DOCUMENTATION CHARGES FOR THE FINAL DOCUMENTS & SOFT COPIES	1 LOT	4 LOT			

TOTAL (A+B+C+D+E+F+G+H+I+J) for FOUR units

PARTICULARS OF THE BIDDER / AUTHORISED REPRESENTATIVE				
NAME	DESIGNATION	SIGNATURE	DATE	COMPANY SEAL

	Technical specification for Control Valves with Accessories (Pneumatically Operated) 4X270 MW MANUGURU	SPEC NO.: PE-TS-411-145-I 801		
		VOLUME	III	
		SECTION		
		REV. NO.	00	DATE : 22.12.2014
		SHEET	OF	

SCHEDULE OF UNIT PRICES

CONTROL VALVE ACCESSORIES

S. No.	ITEMS	UNIT PRICE (Ex-Works)
1.	SMART POSITIONER (EACH TYPE)	
2.	VALVE TRIM OF EACH TYPE (Separate list to be attached if required)	
3.	DIAPHRAGMS,O-RINGS,SEALS ETC OF ALL TYPE,MAKE ETC	
4.	AIR FILTER REGULATORS	
5.	AIR LOCK RELAY	
6.	POSITION LIMIT SWITCH	
7.	VOLUME BOOSTER	
8.	SOLENOID VALVE	
9.	E/P CONVERTER	
10.	PRESSURE GAUGES OF EACH TYPE	
11.	JUNCTION BOX (36 WAYS)	
12.	HANDWHEEL	
13.	ACTUATOR OF EACH TYPE (Separate list to be attached if required)	
14.	BRASS FITTING FOR CONNECTION TO AIR FILTER REGULATOR	
15.	BRASS FITTING FOR CONNECTION TO SOLENOID VALVE	
16.	BRASS FITTINGS FOR CONNECTING TO AIR HEADER	
17.	EQUAL BRASS TEE	
18.	SS TUBING PER METRE	
19.	SS CONNECTOR ½ INCH TO ¼ INCH	
20.	DIAGNOSTIC SOFTWARE	
21.	UNIVERSAL HAND HELD CALIBRATOR	
22.	DTM (DEVISE TYPE MANAGER) / DTD (DEVICE TYPE DESCRIPTION) FILES FOR ENGINEERING.	

PARTICULARS OF THE BIDDER / AUTHORISED REPRESENTATIVE

NAME	DESIGNATION	SIGNATURE	DATE	COMPANY SEAL

	Technical specification for Control Valves with Accessories (Pneumatically Operated)		SPEC NO.: PE-TS-411-145-I 801	
			VOLUME	II B
			SECTION	D
	REV. NO.	00	DATE	: 22.12.2014
			SHEET	
4X270 MW MANUGURU				

CV TEST CHARGES

S.NO	ITEM DESCRIPTION		Qty	CV Test Charges (EX-Works)
S. No.	TAG NO.	SERVICE		
1	AS-2	DEAERATOR PEGGING FROM AS HEADER	1	
2	CD-14	DEAERATOR LEVEL CONTROL	1	
3	CD-21	EXCESS RETURN TO CST	1	
4	CD-25	CEP MINIMUM RECIRCULATION	1	
5	CD-76	CONDENSATE FOR VALVE GLAND SEALING	1	
6	CRH-2	DEAERATOR PEGGING FROM CRH	1	
7	DR-2	HPH-6 NORMAL DRAIN TO HPH-5	1	
8	DR-9	HPH-6 ALT DRAIN TO HP FLASH TANK	1	
9	DR-13	HPH-5 DRAIN TO DEAERATOR	1	
10	DR-16	HPH-5 ALT DRAIN TO HP FLASH TANK	1	
11	DR-19	LPH-3 NORMAL DRAIN TO LPH-2	1	
12	DR-22	LPH-3 ALT DRAIN TO LP FLASH TANK	1	
13	DR-25	LPH-2 NORMAL DRAIN TO LPH-1	1	
14	DR-28	LPH-2 ALT DRAIN TO LP FLASH TANK	1	
15	DR-38	DEAERATOR OVERFLOW TO LP F/TANK	1	
16	FD-14/FD-17	FEED CONTROL VALVE(100% CAPACITY)	1	
17	FD-20	FEED CONTROL VALVE (30% CAPACITY)	1	
18	DM-15	EMERGENCY MUP TO CONDENSER	1	
19	DM-20	NORMAL MUP TO CONDENSER	1	

NOTE: a) CV TEST TO BE CONDUCTED FOR ONE PER TYPE PER SIZE, CV VALUE. TAG NOS. TO BE GROUPED ACCORDINGLY AND INDICATED.



Technical specification for
Control Valves with Accessories
(Pneumatically Operated)

4x270 MW MANUGURU

SPEC NO.: PE-TS-411-145-I 801

VOLUME III

SECTION

REV. NO. 00

DATE : 22.12.2014

SHEET OF

INSPECTION SCHEDULE

(PLACE & ADDRESS OF TESTING/ INSPECTION AND ITS SCHEDULE DATE & DURATION IN NUMBER OF DAYS ITEM/COMPONENTWISE TO BE LISTED)

PARTICULARS OF THE BIDDER / AUTHORISED REPRESENTATIVE

NAME	DESIGNATION	SIGNATURE	DATE	COMPANY SEAL



Technical specification for
Control Valves with Accessories
(Pneumatically Operated)

4x270 MW MANUGURU

SPEC NO.: PE-TS-411-145-I 801

VOLUME II B

SECTION D

REV. NO. 00 DATE : 22.12.2014

SHEET OF

SCHEDULE OF SUBMISSION OF DRAWINGS / DOCUMENTS, EQUIPMENT MANUFACTURE INSPECTION AND DESPATCH

1.	<u>ZERO DATE</u>	<u>DATE of LOI / FOI / TOI</u>
2.	Submission of Data Sheets / documents / catalogues / Valve sizing calculations / Noise calculations for approval.	2 Weeks from the Zero date.
3.	Technical finalization, freezing of inputs of manufacture by way of vetting of documents and technical discussions and resubmissions of documents (if required).	6 Weeks from the Zero date.
4.	Inspection of Equipment as per Approved (Category-I) drawings / documents.	24 Weeks from the Zero date.
5.	Release of MDCC by BHEL.	26 Weeks from the Zero date.
6.	Dispatch (Packaging & Dispatch).	26 Weeks from the Zero date.
7.	Final documents submission as per Contract.	28 Weeks from the Zero date.

NOTE: Delays due to non-fulfillment of the requirements of approved Quality Plan and approved Data sheets; Drawings, Catalogues and Sizing Calculations observed during inspection shall be to the Vendor's account.

Delays due to INCOMPLETE (Partly) submission of Data sheets, Drawings, Catalogues and Sizing Calculations also be considered as "**DOCUMENTS NOT SUBMITTED**"

(Signature and Stamp of the Bidder)