

NOTICE INVITING TENDER

Tender Enquiry No.: TE-FP-14-15-W-31

Date: 12.03.2015

BHEL-Fabrication Plant, Jagdishpur invites sealed bid in two part bid system (Part-I: Techno-commercial Bid; Part II: Price Bid) for entering into rate contract for following work from experienced and financially sound bidder who fulfill the qualifying criteria contained in the enclosed tender document:

1. **Description of work:** Fabrication and assembly of different types of bowl mill sub-assemblies at Fabrication Plant, Jagdishpur.
2. **Quantum of work:** 2000 MT (+/- 10 %)
3. **Duration of Contract:** One year from the date of issue of rate contract.
4. **Cost of tender Document:** ₹ 2,000/-
5. **EMD Amount:** ₹ 2,00,000/-
6. **Due Date and Time for Submission of Bid: 03.04.2015 (2:30 PM)**
7. **Due Date and Time for Opening of Techno-Commercial Bid: 03.04.2015 (3:00 PM)**
8. **BHEL** reserve the right to accept or reject any of the bid/all bids or cancel/withdraw the invitation for bid without assigning any reason whatsoever and in such case no bidder/intending bidders shall have any claim arising out of such action by BHEL.
9. **BHEL** can accept/reject any or all tenders fully or partly, reduce/increase quantum of work without assigning any reasons thereof.

10. Address for submission and opening of Tender:

Tender Box- Administrative Building
Centralised Stamping Unit & Fabrication Plant, BHEL
Industrial Area Jagdishpur
Distt. Amethi- 227817 (U.P.) INDIA

Enclosures to Tender Enquiry:

1. **Section-I: General Terms and Conditions**
2. **Section-II: Special Terms and Conditions**
3. **Section-III: Price Bid format**

Note:

1. The contractors may personally visit the work place to understand the scope of work before submitting their bids.
2. For relevant details please visit our website www.bhel.com. All subsequent corrigendum/amendment shall be published only on website and not in press. Hence, bidders are advised to always be in touch with our said website until the tender is finally opened.

SECTION I

GENERAL TERMS AND CONDITIONS

1. DEFINITIONS:

The following terms and expressions shall have the meaning hereby assigned to them, except where the context otherwise requires:

- 1.1 ~~BHEL~~ shall mean Bharat Heavy Electricals Limited, a Company registered under the Indian Companies Act, 1956 with its Registered Office at BHEL House, Siri Fort, New Delhi, Pin-110049 through its office at CSU & FP-Jagdishpur or its authorized Officers or its Engineers or other employees authorized to deal with any matters with which these persons are concerned on its behalf.
- 1.2 ~~CONTRACTOR~~ or ~~FIRM~~ shall mean the individual, firm or Company who is enlisted with BHEL for providing the services and shall include their executors, administrators, successors and permitted assigns.
- 1.3 ~~CONTRACT~~ or ~~CONTRACT DOCUMENT~~ shall mean and include guidelines and declarations of the registration, the General Terms & Conditions and Statutory Compliances, schedules of quantities, accepted appendices of rates, if any, technical specifications, special specifications, if any, Letter of Intent, agreement & the work order, issued by BHEL. Any conditions or terms stipulated by the bidder in the tender documents or subsequent letters shall not form part of the contract unless specifically accepted in writing by BHEL and incorporated in the work order.
- 1.4 ~~TENDER DOCUMENTS~~ shall mean Instruction to Tenderers, General Terms & Conditions, Special Terms & Conditions, Tender Specifications including drawings and all other documents issued to the bidder against invitation of bid.
- 1.5 ~~LETTER OF INTENT~~ shall mean the intimation by a letter / email / fax to the bidder that the tender has been accepted in accordance with provision contained in that letter. The responsibility of the contractor commences from the date of issue of this letter and all the terms and conditions of contract are applicable from this date.
- 1.6 ~~APPROVED, DIRECTED or INSTRUCTED~~ shall mean approved, directed or instructed by BHEL Shop Engineer / Shop- in-charge/ Concerned authorities.
- 1.7 ~~WORK~~ or ~~CONTRACT WORK~~ shall mean and include the work to be done in relevant work category by the firm or as specified in the Tender documents.

2. OFFICIAL SECRET ACT :

The contractor shall give an undertaking under the official secret Act for maintaining secrecy of the drawings, documents or other records connected with the work given to them. The contractor shall return all the drawings/documents given to them.

3. MODE OF COMMUNICATIONS:

Generally, all communications, references etc. shall be delivered through email, fax or given to the authorized supervisor. It will be undertaken that the contractor has read and understood the message, within three days of the delivery, even if they have not received / not opened/ having

technical problems on their side. Contractor shall communicate their change of authorized supervisor, email address in advance.

4. SECURITIES:

4.1 EARNEST MONEY DEPOSIT (EMD):

4.1.1 Offer should be accompanied with Earnest Money as specified in NIT through in the form of Demand Draft (DD). The DD shall be drawn in favor of %Bharat Heavy Electricals Limited+ payable at Ind. Area Jagdishpur. The EMD shall not carry any interest.

4.1.2 The EMD of the successful bidder will be retained towards part of Security Deposit.

4.1.3 In case of unsuccessful bidder, the EMD will be refunded after finalization of the tender.

4.1.4 BHEL reserves the right of forfeiture of EMD, in case the successful bidder who:

- a. After opening of tender revokes/ withdraws his tender within the validity period or revises/ alters his earlier quoted rates/ conditions.
- b. Fails to communicate unqualified acceptance of Letter of Intent with in one week from the date of issue of letter of intent.
- c. Fails to submit 50% of the total security deposit before start of work.
- d. Fails to submit the work as may be indicated in the Letter of Intent.

4.2 SECURITY DEPOSIT (SD):

4.2.1 Upon acceptance of tender, the successful bidder must deposit the required amount of Security Deposit (SD) after adjusting the amount of Earnest Money duly deposited with the tender, within the time specified in the letter of intent for satisfactory completion of work.

4.2.2 The total amount of Security Deposit shall be as follows:

- a. In the of work costing upto Rs.10 Lakh: 10%
- b. Above Rs.10 lakhs upto Rs. 50 Lakhs: 1 Lakh + 7.5% of the amount exceeding Rs. 10 Lakhs.
- c. Above Rs.50 lakhs: Rs.4 Lakhs+5% of the amount exceeding Rs.50 Lakhs.

4.2.3 The full or 50 % Security Deposit calculated as above shall be deposited with in one week from the date of issue of letter of intent/order but before the start of work in any of the following forms:

- a. Demand Draft in favor of %Bharat Heavy Electricals Limited+ payable at SBI, IGFC Jagdishpur.
- b. Bank Guarantee in the prescribed Performa of BHEL. Bank Guarantee from any one of the consortium banks of BHEL. Validity of the Bank Guarantee furnished towards Security Deposit shall be valid up to the period of completion of work as stipulated in the letter of intent plus 2 months claim period and the same will be kept valid by proper renewal till the satisfactory completion of the Guarantee Period. All charges for establishing and amending the BGs, if necessary, shall be to Contractor's account.

c. Fixed Deposit Receipt issued by Scheduled Banks/ Public Financial Institutions as defined in the Companies Act. The FDR should be in the name of the contractor, A/C BHEL, duly discharged on the back.

4.2.3 If contractor has submitted 50 % of SD, Balance shall be recovered from running @ 10% of the value of each running bill commencing from first running bill itself till the full Security Deposit made up.

4.2.4 If the value of the work done at any time exceeds the accepted Contract Value, the Security Deposit shall be correspondingly enhanced and the extra Security Deposit shall be immediately deposited by the Contractor otherwise it shall be recovered from payments due to him. Failure to deposit the security Deposit within the stipulated time may lead to forfeiture of EMD and cancellation of the award of work. BHEL reserves the right of forfeiture of Security Deposit in addition to other claims and penalties in the event of Contractor's failure to fulfill any of the contractual obligations or in the event of termination of contract as per terms and conditions of the contract.

4.2.5 If the contractor fully performs and complete the works in all respect to the entire satisfaction of BHEL and returns properties belonging to BHEL taken, borrowed or hired by him for carrying out the said work, the full amount of Security Deposit will be released to the contractor after deducting all costs, expenses and other amounts that are to be paid to BHEL under this or other contracts entered into with the Contractor/ released prior to passing of final bill.

5. SUBMISSION OF OFFER / TENDER:

5.1. The bid is invited in either two part or single part as specified in NIT. In case of two part bid system offer shall be submitted as per following:

5.1.1. Part I: Techno commercial Bid: Techno commercial bid should be filled as per **FORMAT-1** to this section and should contain documents in the same order as listed there.

5.1.2 Part II (Price) Bid: Price bid should contain only Price Offer to be submitted strictly as per FORMAT-2 of Price Schedule given in the tender document (Refer Section III). The Price Bid not submitted as per Price Schedule may not be considered.

5.1.3. Part I and Part II Bids should be put in separately sealed envelopes and each envelope must be marked clearly as %Techno commercial Bid+or %Price Bid+as the case may be. NIT Number and bidder's name & address should also be clearly mentioned on these envelopes. These two envelopes must be put in a bigger envelope and sealed properly. Top of the outer cover/envelope should contain following information:

- a. Tender Enquiry No. & Title of Work
- b. Bid Opening date & time
- c. Address/Venue of Bid Submission
- d. Bidder's Name & Address

Technical bid and price bid should be submitted in separate sealed envelopes. In case the bids are found in one single envelope then the %bids+are liable to be rejected.

5.1.4. In case of single part bid system, Techno-commercial bid and price bid should be submitted in single sealed envelope.

-
- 5.1.5 All papers/documents should be ink signed and rubber stamped by the bidder.
- 5.2 The bidder shall quote the rates in English Language using international numerals. These rates shall be entered in figures as well as in words. For the purpose of the tender, the metric system of units shall be used.
- 5.3 All entries in the tender shall either be typed or be written in ink. Overwriting or cutting is not acceptable.
- 5.4 The tender shall be submitted on or before the time & date specified in NIT & shall be dropped into tender box as specified in NIT.
- 5.5 Tenders can be submitted personally/courier/post. The tenders received after the due date and time of submission will be rejected.
- 5.6 Tenders shall be opened by authorized officers of BHEL at the above mentioned address at the time and date specified in the NIT in the presence of such of those bidders or their authorized representative who may like to be present.
- 5.7 The offers should be strictly in accordance with the tender specifications & General Instructions to the bidder. Should the bidder require any clarification on the tender specification, or is interested in offering any deviation from the tender specification, he shall contact the authority inviting the tender for clarification before submission of the tender. No deviation w.r.t. terms & conditions of the tender are acceptable.
- 5.8 If there are varying or conflicting provisions made in any one document forming part of the contract, the Accepting Authority shall be the deciding authority with regard to the intention of the document.
- 5.9 Before tendering, the bidder is advised to inspect the site of work and the environments and be acquainted with the actual working and other prevalent conditions, facilities available etc. No claim will be entertained later on grounds of lack of knowledge.
- 5.10 Validity of Offers: The offer should be valid at least for a period of **90 days** from the date of opening of tender. In case Bharat Heavy Electricals Limited (BHEL) calls for negotiations, such negotiations shall not amount to cancellation or withdrawal of the original offer, which shall be binding, on the bidder. All expenses for attending such negotiations are to be borne by the bidder.
- 5.11 The acceptance of tender will rest with BHEL which does not bind itself to accept the lowest tender or any tender and reserves to itself full rights to reject any or all the tenders.
- 5.12 Conditional and unsigned tenders, tenders containing absurd or unworkable rates and amounts, tenders which are incomplete or otherwise considered defective and tenders not in accordance with the tender conditions, specifications, etc., are liable to be rejected.
- 5.13 If the bidder deliberately gives wrong information in his tender, BHEL reserves the right to reject such tender at any stage or to cancel the contract, if awarded and forfeit the Earnest Money / Security Deposit / any other moneys due.
- 5.14 Canvassing in any form in connection with the tender is strictly prohibited and the tenders submitted by the Bidder who resorts to canvassing are liable to be rejected.
- 5.15 In case of non-conformities/errors/discrepancies are observed between the quoted prices in figures and that in words, following guidelines shall be followed:

(a) If, in the price structure quoted for the required goods / services / works, there is discrepancy between the unit price and the total price (which is obtained by multiplying the unit price by the quantity), the unit price shall prevail and the total price corrected accordingly. Unless in the opinion of the purchaser there is an obvious misplacement of the decimal point in the unit price, in which case the total price as quoted shall govern and the unit price corrected accordingly.

(b) If there is an error in a total corresponding to the addition or subtraction of subtotals, the subtotals shall prevail and the total shall be corrected and

(c) If there is a discrepancy between words and figures, the amount in words shall prevail unless the amount expressed in words is related to an arithmetic error, in which case the amount in figures shall prevail subject of (a) and (b) above.

(d) If there is such discrepancy in an offer the same shall be conveyed to the bidder with target date upto which the bidder has to send his acceptance on the above lines and if the bidder does not agree to the decision of the purchaser, the bid is liable to be ignored.

5.16 BHEL reserve the right to accept or reject any of the bid/all bids or cancel/withdraw the invitation for bid without assigning any reason whatsoever and in such case no bidder/intending bidders shall have any claim arising out of such action by BHEL.

5.17 BHEL can accept/reject any or all tenders fully or partly, reduce/increase quantum of work without assigning any reasons thereof.

6. SIGNING OF TENDER DOCUMENTS

The tenderer shall furnish following, duly enclosing documents relating thereto:-

a) Authorized signatory shall be the person holding power of attorney on behalf of the firm/company/bidder-concerned authorized/empowered to act on behalf for the specific purpose.

b) Power of Attorney: An attested copy of the Power of Attorney, in case an individual other than the sole proprietor signs the tender shall be submitted along with the tenders.

c) In case of an Individual, full name, address, place & nature of business and license relating to.

d) In case of Partnership Firms: The names of all the partners and their address. A copy of the partnership deed/instrument of partnership duly certified by the Notary Public shall be enclosed. The tender must be signed by all the partners of the firm or by the managing partner who has power to do.

BHEL will not be bound by any other power of attorney granted or the change in composition of the firm made after the execution of the contract agreement. They may, however, recognize such power of attorney or change in status only after legal advice.

7. PRICE SCHEDULE (PRICE BID):

7.1 Rate should be quoted strictly as per prescribed Price Schedule.

7.2 The rate quoted by bidder is inclusive of all duties, taxes, fees, octroi, and other levies material, labor etc. except Service Tax which shall be reimbursed to the contractor on actual against documentary proof.

7.3 Prices shall remain firm and no variation what so ever shall be allowed. The bidder is required to take into consideration of cost of wages, material and equipments, PPEs, uniform,

shoes and other consumables and their price fluctuations in the prices of these after the submission of bid and during the period of contract before submission of bid.

8. EVALUATION OF OFFERS

- 8.1 Technical-cum-Commercial Bid (Part-I) shall be opened first on due date specified in NIT.
- 8.2 The bidders shall be evaluated as per qualifying requirements mentioned in the tender documents.
- 8.3 Price Bid (Part-II) shall be opened only of Technical-cum-Commercial qualified bidder.
- 8.4 The bidder shall submit complete price of the package. Total price of the package (Price Schedule) shall be compared for purpose of arriving at L1.
- 8.5 Evaluation of the offer will be strictly based on the information submitted by the bidder. In view of this the bidder is requested to go through tender document carefully and furnish all details clearly. Missing information may not be asked by BHEL.
- 8.6 In case of tie between two or more than two bidders for L1 price. Bids shall be called for discount on price offered in sealed envelope from all the L1 bidders.
- 8.7 BHEL reserve the right to split the work in two or more vendors, if required. If not specified, total work in full shall be ordered on a single party i.e. L-1 bidder.
- 8.8 BHEL reserves its right to negotiate with the Bidder and/ or go for Reverse Auction (RA).

9. REVERSE AUCTION:

- 9.1 BHEL may go for Reverse Auction (on line bidding on Internet) instead of opening the submitted sealed price bid. The decision to go for Reverse Auction will be taken after techno-commercial evaluation. Only technically and commercially acceptable bidders shall be eligible to participate in reverse auction. Information and general terms and conditions governing RA shall be communicated to technically and commercially acceptable bidders.
- 9.2 In case BHEL decides not to go for Reverse Auction procedure for this tender enquiry, the Price bids already submitted and available with BHEL shall be opened as per BHEL's standard practice.

10. CONTRACT AGREEMENT

The successful bidder (Contractor) has to make an agreement with BHEL in the format prescribed by BHEL on Rs. 100/- Non-Judicial Stamp Paper at his own cost.

11. TERMS OF PAYMENT:

- 11.1 Payment shall be made, on the Nos. of Measurement units, successfully executed, by the Contractor. The contractor shall submit their clear & legible bills (in duplicate) on Monthly basis, duly verified by concerned BHEL staff. Each bill must be enclosed with work/ activity completion report duly signed by contractor & and BHEL representative (s).
- 11.2 All payments shall be released through electronic-pay mode only.
- 11.3 BHEL shall be releasing payments against the work order after deduction of income tax at source (TDS) as per requirement of income tax rules and BHEL will issue appropriate certificates in this regard.
- 11.4 Service tax, if applicable, shall be paid, as per Govt. rules, to the contractor against running actual, on documentary evidence. The Service tax shall be paid extra and over the quoted rate.

-
- 11.5 No interest shall be payable by BHEL on Earnest Money, Security Deposit or on any money due to the firm by BHEL.
 - 11.6 Firm shall arrange his own finance for smooth execution of contract, wages payment, other statutory payments to his employees and all other agreed conditions.
 - 11.7 Normally, payment shall be made within 45 days of receipt of bill at BHEL.

12. PENALTY :

For late completion of work, BHEL standard LD clause shall be applicable which is 0.5% per week for unexecuted portion of work subject to maximum 10% of work order value. Cost of rejection, as appropriate shall be recovered from contractor as compensation for defective job done resulting in rejection even after performing necessary rework.

13. SAFETY AND OCCUPATIONAL HEALTH:

The contractor has to assume full responsibility of the safety of the vehicles/ equipments, crew and to comply with the security/ safety regulations of BHEL and Government, as applicable, inside the BHEL factory. The contractor is required to keep and maintain first aid box at work place at his own cost.

14. FORCE MAJEURE:

Notwithstanding anything contained in this Contract, neither the Contractor and nor the BHEL shall be held responsible for total or partial non execution of any of the contractual obligations, should the obligation be made impossible due to concurrence of a Force Majeure which will include war, military operations of any nature, blockages, revolutions, insurrections, riots, civil commotions, insurgency, sabotage, act of public enemy, acts of god, epidemics and act of Govt. over which the Supplier or BHEL has no control.

15. ARBITRATION:

All disputes arising in connection with the contract shall be settled by mutual consultation. If no agreement is reached the dispute shall be settled in accordance with Arbitration and conciliation Act, 1996 and the rules made there under. The dispute shall be referred for arbitration to any arbitrator to be appointed by the General Manager. The award of the arbitrator shall be final and binding on both the parties. The venue of the Arbitration shall be at Sultanpur, India. The Award to be given by the Arbitration shall be a speaking award. All questions, disputes, differences arising under, out of or in connection with this contract shall be to the exclusive jurisdiction of Sultanpur court.

16. RIGHTS OF BHEL :

BHEL reserves to itself, the following rights without entitling the Contractor to any compensation. Resorting to any, some, all of the actions like Contract termination, recovering the dues/ losses from the Security Deposit and the contract amount, forfeiting the Security Deposit, getting the work done through other agencies at the cost of the contractor, cancellation of registration, banning the business with BHEL etc., in any event of the followings:

- a) Contractor's repeated poor performance, withdrawal from or abandonment of the work, except in force majeure conditions.
- b) Serious lapse in performance, Persistence disregard of the BHEL instructions.
- c) Insolvency of the contractor.

-
- d) Assignment, transfer, subletting of the contract work without BHEL's written permission.
 - e) Non-fulfilment of any contractual obligations or obligations under the law.

17. ABANDONING OF WORK:

If the Contractor fails to perform/execute the work within time or fail to perform as per the specification prescribed in tender or acted in violation to prescribed terms and conditions, BHEL shall be entitled to terminate the Contract and take recourse to alternate source to get the work done at the risk and cost of the Contractor. In such case Contractor shall make good the loss to BHEL. BHEL shall be entitled to recover the difference in cost, if any incurred by BHEL due to getting the work done from alternate source. However, in such case Contractor shall not be entitled for any gain.

18. TERMINATION

This contract may be terminated at any time without paying any compensation whatsoever to the Contractor in case of misbehaviour, disobedience, dishonesty, clandestine insolvency, any court order or any other related activities on their part or their failure to fulfil the terms and conditions of this contract or agreement.

BHEL reserves the right to terminate contract awarded for any contravention of statutory provision or any other reasons without assigning any explanation or notice to the contractor.

19. EXTENSION

The contract may be extended as per BHEL's policy on mutual agreement of BHEL and the contractor.

20. PREFERENCES FOR MSMEs:

Following preferences/benefits shall be given to MSEs in line with Public procurement policy for Micro and Small Enterprises (MSEs), 2012:

- a. The tender documents shall be issued free of cost to MSEs.
- b. MSEs are exempted from payment of Earnest Money Deposit (EMD).
- c. In tender, Micro and Small Enterprises quoting within the price band of L1+15% shall be allowed to supply the requirement up to 20% of the tender quantity subject to condition that such Enterprises bring down their price to L1 price where L1 price is from other than a Micro and Small Enterprise. If L1 offer is from a Micro / Small Enterprise, this provision will not be applicable. In case more than one Micro and Small Enterprise is there within this span, the supply shall be shared proportionate to the tender quantity. (70:30 or 50:30:20 of the eligible quantity).

Note: Special provision for Micro and small enterprises owned by SC or ST: -

Sub target of 20% (i.e. 4% out of 20%) would be earmarked for procurement from Micro and Small Enterprises owned by the Scheduled Caste or Scheduled Tribe Entrepreneurs provided that in event of failure of such Micro and Small Enterprises to participate in the tender process or meet the tender requirements and the L1 price, the 4% sub-target for procurement ear-marked

MSE owned by Scheduled Caste or Scheduled Tribe Entrepreneurs shall be met from other MSE Enterprises/s.

MSE suppliers can avail the intended benefits only if they submit along with the offer, attested copies of either EM II certificate having deemed validity (five years from the date of issue of acknowledgement in EM II) or valid NSIC certificate or EM II certificate along with attested copy of a CA certificate (Format enclosed at Annexure -1 where deemed validity of EM II certificate of five years has expired) applicable for the relevant financial year (latest audited). Date to be reckoned for determining the deemed validity will be the date of bid opening (Part 1 in case of two part bid). Non submission of such documents will lead to consideration of their bid at par with other bidders. No benefit shall be applicable for this enquiry if any deficiency in the above required documents is not submitted before price bid opening. If the tender is to be submitted through e-procurement portal, then the above required documents are to be uploaded on the portal. Documents should be notarized or attested by a Gazetted officer.

In case of any change in the MSE status of the Bidder, it shall be the responsibility of the Bidder to notify the change as a part of the Bid document. If at a later date it comes to the knowledge of BHEL, that the change in the status has not been intimated by the Bidder and the order is obtained under the premise of an MSE then BHEL would cancel the pending order against this tender and take necessary steps for suspension of the business dealing with the Bidder as per the procurement policy of BHEL.

In case after the bid opening it is seen that no MSE has become L1, then depending on the nature of the item, if it is not possible to split the tendered items / quantities on account of reasons like customer contract requirements of supplying one make for a given project or technical reasons like the tendered item being a system etc. then BHEL would not counter offer the L1 prices even though there may be MSE bidders within the +15% band of L1.

21. TERMS & CONDITIONS FOR CONTRACTORS FOR DEPLOYMENT OF CONTRACT LABORERS UNDER SERVICE OR WORKS CONTRACT

21.1 LABOUR LICENCE AND OTHER REQUIREMENTS

21.1.1 Contractor should possess Labour license in case of contractors working in BHEL CSU & FP Jagdishpur and deploying 20 or more labours on any day, from the Appropriate Government (Central Govt.) for carrying out the various activities mentioned in the contract document.

21.1.2 The contractor shall deploy such number of workers in the premises of BHEL CSU & FP Jagdishpur, as required for completion of the contract. The workers such deployed shall be his own workers.

21.1.3 In case the number of labour deployed by the contractor in premises of BHEL CSU & FP Jagdishpur exceeds the number of labour allowed in the license then the contractor shall immediately inform the HR and concerned department. The contractor shall also apply to the licensing officer in the region for amendment in the license within 7 days of exceeding the number of labours mentioned in the license.

21.1.4 Labour license and other requirement in case of contractors NOT working in BHEL CSU & FP Jagdishpur or has less than 20 workers on his rolls:

A) The contractor should possess valid labour license issued by any licensing authority if he has deployed 20 or more workers in any organization.

B) After being eligible to apply as above, if the contractor is awarded the contract then he should apply for Form-V from BHEL to obtain Labour License from Appropriate Government and submit the same within one month from the date of award of contract. Till then award will be treated as PROVISIONAL.

21.1.5 The contractor shall also have to submit copy of PAN card and latest IT return.

21.1.6 The contractor must possess Service Tax Registration number under relevant code head.

21.1.7 The contractor should possess VAT/TIN Number if material is supplied/consumed. The contractor should not be disqualified from bidding in case the contractor does not have TIN No. However, he shall have to produce TIN No. before opening of Price bid.

21.2 APPOINTMENT AND ENTRY IN FACTORY PREMISES

21.2.1 The contractor shall submit the following to HR through contracting department:

- The details of the worker proposed to be deployed.
- Police Verification Certificate by appropriate authority or Character certificate issued by District Magistrate's Office or Proof of remittance of fees for character certificate at District Magistrate's Office. Further he should submit the character certificate within 30 days failing which he will be discontinued.
- Copy of employment card issued by contractor to his own worker.

21.2.2 After submission of documents as in Para 2.1, the contractor shall issue photo identity card to the labour and submit to HR department. This identity card shall be forwarded by HR department to BHEL Security, which shall then authorize the labour to enter the factory premises initially for a period of one month.

21.2.3 The photo identity card shall have to be revalidated in every three month on last working day of the month or any other date fixed to do so. In absence of such revalidation, duly forwarded by HR department, BHEL Security shall not allow any labour to enter the premises of BHEL CSU & FP Jagdishpur.

21.2.4 The contractor shall maintain a register of persons employed by him in the format prescribed under Rule 75 of Contract Labour (R&A) Central Rules.

21.3 BILLS PAYMENT, ATTENDANCE AND PAYMENT OF WAGES

21.3.1 The Contractor shall pay wages to all his Laborers as prescribed by the BHEL HR from time to time based on government norms.

21.3.2 In addition to minimum daily wages above, an **additional wage** has also to be paid by the Contractor to all his Laborers as per following rates as per BHEL guidelines:

Sl. No.	Type of Labour	Additional daily wage to be paid in (Rs.) as on date (22.05.2014)
1	Unskilled Worker (USW)	123.08
2	Semi-skilled Worker (SSW)	142.31
3	Skilled Worker (SW)	157.69
4	Highly Skilled Worker (HSW)	157.69

This additional amount will also attract all statutory deductions and payments.

- 21.3.3 Contractor shall ensure payment of wages as applicable on or before seventh day of each month.
- 21.3.4 Wages payment shall be made by Contractor to the Laborers through bank / cheque / cash in the presence of authorized BHEL representatives and shall maintain proper records of their timely disbursement. Contractor shall issue wages slips to his laborers.
- 21.3.5 The payment of wages to the workers shall not be subject to payment against the bills by BHEL.
- 21.3.6 The contractor shall submit bills to the contracting department by 8th of each month.
- 21.3.7 The contractor's bills should be accompanied with the following:-
- a) Copy of Measurement Book entries / Statement of work done / work completion report by the Contractor duly verified by concerned BHEL representative(s).
 - b) Statement of Minimum Wages of labours deployed by him under the Service contract, PF/ESI no., statutory deductions etc., (Form XVII of Contract Labour (R&A) Rules)
 - c) PF and ESI challans for previous month-separate for concerned Service contract. Print of online challan along with list of contributing contract workers for ESI duly certified by the contractor.
 - d) Wage payment sheet for the bill period.
 - e) Statement of material supplied by the contractor, if any
 - f) Copy of Labour Licence if increase in no. of labours deployed against Work Order if applicable.
 - g) Copy of Challan of previous Service Tax paid.
- 21.3.8 The contractor shall remit the cheques favouring RPFC and ESI Office with the appropriate banks with such period as stipulated under relevant provisions. Last date for remittance of PF is 15th and that in case of ESI is 21st of each month.

21.4 PROVIDENT FUND (PF)

- 21.4.1 The Contractor should allot PF account number and get the nomination form, duly filled in, from each worker deployed by him at the time of joining.
- 21.4.2 In case the worker already has PF/pension account number, allotted to him, previously, then the contractor shall get the transfer form filled up at the time of joining and send to the office of concerned Regional Provident Fund Commissioner.
- 21.4.3 After termination of contract the contractor shall provide due assistance to the labour for withdrawal of PF/pension amount, when due.
- 21.4.4 The Contractor shall liaison with the PF officials to get the annual PF slips and distribute amongst his own workers. Security deposit shall be released only after submission of PF slips of workers.

21.4.5 PF CONTRIBUTION:

Employee's Contribution

Employer's Contribution

12.00%

13.61 %

21.4.6 The Contractor shall submit annual returns in Form-6A and Form 3A, prescribed under statutory EPF scheme, 1952, in respect of each worker deployed by him with a copy to HR.

21.5 EMPLOYEES STATE INSURANCE (ESI)

21.5.1 The Contractor should allot ESI account number and get the nomination form, duly filled in, from each labour deployed by him at the time of joining.

21.5.2 At the time of joining the contractor shall get the self/family registration form filled by the workers and submit to the local ESI office.

21.5.3 The contractor shall facilitate collection of issued ESI cards by his worker.

21.5.4 ESI CONTRIBUTION :-

<u>Employee's Contribution</u>	<u>Employer Contribution</u>
1.75%	4.75%

21.5.5 The Contractor shall submit annual returns in Form-6 prescribed under ESI Act, deployed by him with a copy to HR and finance department.

21.5.6 The Contractor shall produce the following Registers and forms as per Contract Labour (R & A) Rules 1971 for verification by the concerned BHEL Officer(s):

- (a) Form XII - Register of contractors (Rule 74)
- (b) Form XIII - Register of Workmen employed by contractor (Rule 75)
- (c) Form XIV - Employment Card issued by contractor (Rule 76)
- (d) Form XVI - Muster Roll 78(1) (a) (i)
- (e) Form XVII - Register of Wages (Rule 78 (1) (a) (i))
- (f) Form XVIII - Register of wages-cum Muster Roll (in case of weekly Payment)
- (g) Form XIX - Wage Slip (Rule 78)(1) (b)
- (h) Form XX - Register of deduction for damages of loss (Rule (78)(1) (a) (ii))
- (i) Form XXI - Register of fines (Rule 78) (1) (a) (ii)
- (j) Form XXII - Register of advance (Rule 78) (1) (a) (ii)
- (k) Form XXIII - Register of overtime (Rule 78) (1) (a) (iii)
- (l) Form XXIV - Return to be sent by the contractor to licensing officer (Rule 82)

21.6 BONUS

The contractor shall be liable to pay statutory bonus under payment of Bonus Act, 1965

21.7 DISCIPLINE

21.7.1 The Contractor shall be responsible for the discipline of his own laborers deployed under the service contract. In case of any loss to the BHEL CSU & FP Jagdishpur on account of indiscipline of contract laborer then such loss shall be assessed and recovered from the running bills of the contractor or from the security deposit.

21.7.2 The contractor shall not employ any person who has not completed his 18 years of age and person who has attained 60 years of age.

21.7.3 The contractor, on advice of authorized BHEL official, shall immediately remove any person employed by him, who may in the opinion of such authorized BHEL official is involved in misconduct. Such person shall not be re-employed by the contractor without prior permission.

21.8 LEAVE WITH WAGES TO CONTRACT LABOUR

Guidelines as per UP factories Rules 1950 should be strictly observed with regard to crediting / availment of leave. Register as prescribed under the said Rules should be maintained by the contractor.

21.9 SAFETY OF OPERATION

The total safety of operation and laborers is Contractor's responsibility. Contractor should provide the following Personnel Protective Equipment (PPE) and Consumables, as applicable, to each laborer during execution of the contract, at his own cost:-

- a) One pair of Uniform within two weeks of start of contract and one pair within next six months.
- b) One safety helmet per annum, (within two weeks of start of contract)
- c) One pair of safety shoes along with two pairs of socks per annum, (within two week of start of contract).
- d) One pairs of leather hand gloves per week.
- e) Two pairs of Ear plugs per month
- f) Cora cloth / Cloth Waste 1/2 Mt. per month
- g) One soap per month.
- h) Any other relevant safety PPEs, if required.

Quantities mentioned above are minimum and may increase depending upon operation / job and contractor has to provide these items at his own cost. Each PPE items should follow BHEL Safety Engineering Standards. The contractor shall maintain a register for record of above items.

21.10 SUPERVISION OF CONTRACTOR LABORERS:

The contractor shall appoint one identified supervisor for monitoring and controlling of work and laborers. All issues regarding discipline at the works are to be supervisor's responsibility. The Contractor shall submit an authorization certificate to in name of his supervisor. No extra supervision charges shall be paid by BHEL.

21.11 CONTRACT LABOUR ACCIDENTS WHILE AT WORK:

In case of medical emergencies faced by contract worker at work, medical facilities in the interest of the well-being of the worker shall be provided by BHEL. The decision of the doctors attending the emergency shall be final and binding. The cost incurred shall be deducted from the bills of the contractor. The Contractor shall complete the ESI formalities and BHEL shall submit claim of reimbursement of medical expenses to ESI. The amount reimbursed by ESI shall be paid back to the contractor.

21.12 PROHIBITION ON INFLUENCING AND INTERFERING ON BEHALF OF CONTRACTOR:

The Contractor shall neither try to influence, chase or interfere into the working of BHEL officials nor engage BHEL employee or any other third person for the same. In case such incident does occur, it may lead to disqualification/debarring from the contract. Any contractor shall be debarred from consideration if any of his relations is working in the product/functional group in which the contract is being issued. Before issuing tender form to any contractor for limited tender enquiry a confirmation has to be given by contractor that none of his relations are working in that product/functional group.+

21.13 GENERAL GUIDELINES TO CONTRACTOR:

- 21.13.1 The contractor will comply with all the provisions regarding licensing, welfare and health, procedures, maintenance of various records and registers etc., as provided under the contract Labour (Regulation & abolition) Act 1970, rules amendments, orders, notifications there under issued by the Appropriate Government from time to time. For non-compliance of any provisions, statutory compliance under law, the contractor shall be responsible for penalties levied by the appropriate authority under the Act. The contractor shall also be liable to comply with all other Labour and Industrial Laws and such other acts and Statutes (including Factories Act, Payment of Bonus Act, minimum wages Act, etc.). Depositing of ESI, PF contribution as may be applicable is the responsibility of the contractor. For any default in compliance, the contractor shall be held responsible.
- 21.13.2 The Contractor shall compensate BHEL for any loss or damage to the plant/property, material of BHEL due to his workmen/representatives negligence or otherwise during execution of work.
- 21.13.3 All the workers should be provided with uniform & identity cards by the contractors. The contractor has to provide a distinct uniform different from BHEL employees. The Uniform shall be kept in neat, tidy & wearable condition.
- 21.13.4 The contractor shall be responsible for the good conduct of his employees.
- 21.13.5 The contractor shall be responsible for all acts and omissions of their staff and liabilities arising out of the acts and omissions of such staff shall be borne by the contractor, BHEL shall in no way be responsible for any such acts, omissions or any liabilities arising there from.
- 21.13.6 The Contractor shall arrange necessary Insurance cover/Personal Accident Policy as applicable for their staff. If any accident/injury/loss/ occurs due to the operation of any equipments, to any other persons/public and the properties of BHEL/client/other agencies/third party, the contractor shall have to pay necessary compensation and other expense, so decided by the appropriate authorities/victims.
- 21.13.7 Only the authorized staff attached to the contracted work or representative nominated by the contractor shall be allowed entry inside the company or any other premises during the period of contract.
- 21.13.8 The persons employed by the Contractor in respect of work will treated as the authorized representative(s) and shall also be held responsible along with the contractors, for any breach of the terms and conditions as provided in this contract.

21.13.9 If BHEL Executive feels that the persons deployed on job are not having required skill to perform the job, the contractor will have to replace those persons by adequately trained staff.

21.13.10 Accident occurred during the course of company's work should be reports by the Contractors to BHEL immediately and certainly not later than 24 hours. This should be followed by a detailed report from the contractor.

21.13.11 The Contractor will have to indemnify BHEL against:

- (a) All claims for injury or damage to any person or property caused by his negligence of his employees whilst in BHEL premises.
- (b) Observance of Labor & Industrial Laws, including regular remittance to EPF and ESI.
- (c) All claims by way of compensation and all other types of unforeseen claims, which may arise in the period of contract.
- (d) The Contractor will accept liability for compensation in accordance with the provision of the Indian Workers' Compensation Act, 1948, amendments thereafter and or other law for the time being in force for personal injury caused to any workmen by accident arising out of and in the course of this contract.
- (e) The Contractor will indemnify the company against all payments by way of compensation or otherwise which the company may be called upon to make under the provisions of the said Acts to any workmen as aforesaid, and any cost incurred by the company in connection with any claim preferred by such workmen and or against all actions, claims and demand whatsoever in respect thereof or in respect of any loss, injury or damages whatsoever to any third person arising out or occasioned by the negligent, imperfect or improper performance of this contract by the Contractor, their workmen servants or agents.
- (f) The Company shall not be held liable for any loss, damage or compensation to third parties arising from or in relation to transport operation done by the bidder, such loss, damage or compensation shall be reimbursed by the Contractor to the company together with the costs incurred by the company on any legal proceedings pertaining there to.

The Contractor will be required to submit Indemnity Bond in favor of BHEL on a Non Judicial Stamp paper of appropriate value.

ANNEXURE A

(to be made on Bidder's letter head)

DECLARATION SHEET

I / We hereby certify that, all the information and data furnished by me / us with regard to this Tender are true and complete to the best of my / our knowledge. I / We have gone through the specification, conditions and stipulations in detail and understand fully the scope of work and agree to comply with the requirement and intent of specification.

I/We, further certify that I/We am/are the duly authorized representative(s) of the under mentioned bidder and a valid power of attorney to this effect is also enclosed.

I/We, hereby declare that I/We shall treat the tender documents, drawings, specifications and other records connected with the work as secret / confidential and shall not communicate information / derived there from to any persons other than a person I/We am/are authorized to communicate the same or use the information in any manner prejudicial to the safety of the same.

I / We hereby also give our consent in acceptance of all terms and conditions of this tender without any deviation.

Date:

Name & Signature of the bidder

(Seal)

(to be made on Bidder's letter head)

CERTIFICATE OF DECLARATION CONFIRMING THE KNOWLEDGE OF SITE CONDITION

I/We hereby declare and confirm that we have visited the project site under the subject given in NIT and acquired full knowledge and information about the site conditions, wage structure, industrial climate and total work involved. We further confirm that the above information is true and correct and we will not raise any claim of any nature due to lack of knowledge of site condition.

Date:

Name & Signature of the bidder
(Seal)

ANNEXURE C

(to be made on Bidder's letter head)

TO WHOM SO EVER IT MAY CONCERN

This is to certify that our firm is not blacklisted / under hold from BHEL Jagdishpur or banned by any unit/region/office of BHEL.

This is to certify that we / our firm is not guilty by a Court of Law in India for any offence involving fraud, dishonesty and moral turpitude

Date:

(Signature of Authorized Signatory)

ANNEXURE D

(Certificate by Chartered Accountant on letter head)

This is to Certify that M/S.
(Hereinafter referred to as 'company') having its registered office at
.....is registered under MSMED Act 2006, (Entrepreneur
Memorandum No (Part-11dated:
Category: (Micro/Small) (Copy enclosed).
Further verified from the Books of Accounts that the investment of the company as on date
..... as per MSMED Act 2006 is as follows:

1. For Manufacturing Enterprises: Investment in plant and machinery (i.e. original cost excluding land and building and the items specified by the Ministry of Small Scale Industries vide its notification No.S.O.1722(E) dated October 5, 2006 :

Rs.Lacs

2. For Service Enterprises: Investment in equipment (original cost excluding land and building and furniture, fittings and other items not directly related to the service rendered or as may be notified under the MSMED Act, 2006:

RsLacs

(Strike off whichever is not applicable)

The above investment of Rs Lacs is within permissible limit of Rs -----Lacs for Micro/Small (Strike off which is not applicable) Category under MSMED Act 2006.

Or

The company has been graduated from its original category (Micro/ Small) (Strike off which is not applicable) and the date of graduation of such enterprise from its original category is -----

----(dd/mm/yyyy) which is within the period of 3 years from the date of graduation of such enterprise from its original category as notified vide 5.0. No. 3322(E) dated 01.11.2013 published in the gazette notification dated 04.11.2013 by Ministry of MSME.

Date:

(Signature)

Name -

Membership number

Seal of Chartered Accountant

Format-1

TECHNICAL BID FORMAT

TABLE-I

Sl. No.	Description	Please Fill
1	Name of the Firm (Bidder)	
2	Address of the Firm (Registered Office)	
3	Name of Contact Person	
4	Contact Numbers	
5	Fax No., if any	
6	Email ID	

TABLE-2

Sl. No.	Description	YES / NO	Remarks
1	Earnest Money Deposit (EMD)		D.D. Number & Date
2	Tender Document Cost, if applicable		D.D. Number & Date
3	Signed and stamped copy of tender documents		Signed and stamped Copy of all pages (all sections) of BHEL tender documents to be enclosed as a token of acceptance of all terms and conditions of the tender
4	Un-Priced bid (<i>Price bid format without prices</i>)		Signed and stamped copy Blank price bid to be submitted
5	Documents against Qualifying Requirements		Signed and stamped copies of all documents as asked under qualifying criteria of the tender to be enclosed
6	Authorization for signing Tender Documents		Valid copy of power of attorney / authorized signatory to be enclosed as a proof of authorized representative of the firm
7	Signed and stamped copies of all Annexures		Signed and stamped Copies of all Annexures A, B, C & D (D if applicable) to be submitted on firm's letter head
8	Labour License Number		Copy of the License to be enclosed
9	PF Code Number		Copy of the Certificate to be enclosed
10	ESI Code Number		Copy of the Certificate to be enclosed
11	PAN Number		Copy of the PAN Card to be enclosed
12	Income Tax Return (<i>of last 3 yrs</i>)		Copy of the ITR to be enclosed
13	Service Tax Registration Number		Copy of the Certificate to be enclosed
14	Validity of Offer		90 days from the date of tender Opening

Please mention "NA" if not applicable.

I / We hereby certify that, all the information and data furnished above with regard to this Tender are true and complete to the best of my / our knowledge.

Date:

(Signature and Seal of Bidder)

SECTION II

SPECIAL TERMS AND CONDITIONS

(The 'Special Terms and Conditions' given hereunder supersede the relevant terms and conditions given in 'General Terms and Conditions')

A. SAILENT FEATURES OF RATE CONTRACT:

The salient features of the Rate Contract (RC) Tender is detailed below:

1. This is an open tender enquiry inviting quotations for entering into Rate Contract, for carrying out Fabrication and assembly of different types of bowl mill sub-assemblies at Fabrication Plant, Jagdishpur as per scope of work.
2. Only those contractors meeting the pre-qualification criteria are eligible to participate in the tender.
3. The rate contract shall be valid for 12 months for placement of WO from the date of issue of rate contract. However, the period may be extended for next 12 Months by mutual consent of BHEL & contractor.
4. The rate contract tender is for a tentative quantity of 2000 MT (+/- 10 %) of fabrication to be ordered over a period of 12 months.
5. The sample drawings are attached with this tender enquiry and can also be collected for study from BHEL for reference before submission of quotation. Drawings will be tentative, actual Drawings will be given along with work orders.
6. No price variation / price increase shall be entertained for any reason during the tenure of the contract.
7. Conditional offers if any submitted by the firms will not be acceptable.
8. No revision of prices will be entertained after the tender is opened.

B. ORDERING / LOADING OF JOBS:

1. The award of works is proposed to be distributed to a maximum of 6 bidders, subject to acceptance of the L-1 rates only. The L-1 rates decided after price bid opening/Reverse Auction/negotiation shall be counter-offered to all the techno-commercially acceptable bidders i.e. L2, L3, L4, L5 so onõ ... onwards except highest quoted bidder. The bidder quoting highest rate will be eliminated from this Rate Contract.
2. Upon acceptance of L-1 rate by other bidders, a rate contract shall be entered for the work with maximum of first six bidders (low to high) who accept the counter offered L-1 rate. In case number of bidder available for quantity distribution are 7 or less than 7, then the distribution shall be done amongst (N-1) bidders where N is the number of qualified bidders available for qty. distribution. The work Distribution Percentage (%) shall be as follows:

No. of bidder (N)	L-1	L-2	L-3	L-4	L-5	L-6	Total
7	29	24	19	14	9	5	100
6	34	26	20	13	7	0	100
5	40	30	20	10	0	0	100
4	50	34	16	0	0	0	100

3. If no. of qualified bidder available for quantity distribution is less than 4, then BHEL will decide the distribution in later stage keeping in view that L-1 will get the major share of work.
4. Based on availability of order with BHEL, the WOs shall be placed in a phased manner to those contractors with whom rate contract is entered. There is a variation of +/-10 % is allowed due to drawing weight of assemblies in individual orders.
5. The WOs shall be issued in sets of bowl mill sub-assemblies. Generally, one set consist of 1 no. separator body, 1 no. Separator Top static/Dynamic and 1 no. Mill side housing.
6. The allotment of job shall be done by BHEL and contractors have no choice to select the job.
7. It is expected that contractors should deliver quality products. However, in case any complaint is received from customer/QC/Production regarding poor quality of product, all the connected expenditure involved in repair / rework with BHEL's overhead charges (30%) shall be recovered from contractor's bill. In case of repeated complaints on same contractor, the contractor will be delisted from BHEL and no business shall be given for next three years

C. SCOPE OF WORK:

1. The contractor shall be responsible for Fabrication and assembly of different types of Bowl mill sub-assemblies like Separator Bodies, Separator Top Dynamic, Separator Top Static, Mill Side Housing etc. as per drawing provided by BHEL at Fabrication Plant, Jagdishpur as follows:
 - I. Study of Drawings: BHEL will provide drawings of jobs to be completed. Contractor shall study the drawings and prepare cutting plan and sub assembly drawings, if required. Contractor shall submit the cutting plan and get it approved from concern engineer in charge/AE.
 - II. Receipt of Material: Cutting of major raw material shall be done by BHEL based on approved cutting plan. However, small components which can be cut by PUG machines/Gas Cutting torches shall be done by contractor. Cut to size materials shall be received by contractor from BHEL Shop In-charge. Grinding/dressing/cleaning of flame cut components, maintaining dimensions as per drawing, if required shall be responsibility of contractor. All Bought Items shall be provided by BHEL.
 - III. Preparation of material: All material preparation works e.g. Chamfering, grinding etc. except rolling/bending shall be done by contractor. Rolling/bending shall be in BHEL's Scope. However, assistance of manpower for rolling/Bending will be provided by contractor, if required.
 - IV. Assembly: Assembly of all prepared components as per drawing shall be done by contractor. The fitting, marking and tacking of components as per drawing shall be done by contractor. All assemblies shall be fabricated to given drawings and notes thereon.
 - V. Welding: Welding of all joints as per drawing shall be done by contractor. Welding includes assembly of flange, cylinder & Root run of cylinder and flange assembly. All welding shall be performed as per approved WPS provided by BHEL by qualified welders only. Contractor shall carryout the welding in such a manner that no distortion takes place. Due care shall be taken to control the distortion by suitably clamping the assembly during welding. The arcing on parent material and machined faces should be avoided strictly.
 - VI. Dressing: Strict measures of quality control should be maintained throughout the work. The job should be free from spatters and undercuts. All dressing and cleaning shall have to be done to the satisfaction of Engineer In-charge/BHEL-QC.

-
- VII. Proof Marking: Final job shall be proof marked clearly punched on the assemblies as per drawing requirement before handing over to BHEL.
- VIII. Job Identification: The job to be identified by hard punching as per details provided by BHEL.
2. The fabrications shall strictly conform to dimensions and tolerances indicated in the drawings, QAP/SQP. Care must be taken to strictly adhere to the %NOTE+given in the drawings. They must ensure that correct dimensions and deviations, if any, are recorded properly in the D.R. books and the same shall be made available to BHEL.
 3. Welding to be carried out by Qualified Welder and as per BHEL Approved Welding Procedure Specification. The welder qualification and welding procedure (as per relevant SIP) shall have to be done by QC / BHEL or by their authorized appointed agency as & when required. The contractor shall submit the list of qualified welders to BHEL before starting the work.
 4. If any deviation to the above is observed at customer's end, the same is to be reworked at contractor's Cost.
 5. Contractor to submit their internal inspection reports in appropriate format before offering the job for inspection by BHEL QC. Inspection at various stages during fabrication shall be done by BHEL - QC and proper record by Contractor shall be maintained.
 6. DPT at various stage of welding shall be done by contractor and submit the report. BHEL may witness the DPT and verify the reports submitted. DPT kit shall be provided by BHEL.
 7. RT/UT shall be carried out as per drawing requirement/QAP by BHEL. Re-work to be done, if required by BHEL QC without any charge. If there is repeated failure of welding joints are observed during RT/UT, suitable penal action like deduction of extra weld deposits, closure of contract, recovering material cost etc. shall be taken against contractor.
 8. Inspection / clearance of fabricated assemblies by BHEL QC shall be Contractor's responsibility. Fabricated assemblies should not fail in post weld heat treatment and final testing as mentioned in drawing/QAP.
 9. Raw material, electricity, consumables like electrodes, MIG Wire, grinding wheels, cutting wheels, gases available with BHEL, shall be provided by BHEL free of cost. Contractor shall maintain records of the material and consumables issued by BHEL and submit the monthly report to BHEL.
 10. Electricity shall be provided by BHEL at single point only near to their workstation. The distribution of power in their machines through SFU/TPN, isolators, bus bars, wires, cables, distribution board etc. of suitable rating shall be arranged by contractor themselves.
 11. Suitable machines / equipment such as welding machines, grinding machines, Small portable drilling machines and their drill bits, PUG cutting machines, Gas cutting torches along with all their accessories, electrode carrying oven, handling facilities and other tools and tackles required for execution of job shall be arranged by Contractor.
 12. All the electrical appliances deployed by contractor must be in healthy condition and safe for operation.
 13. Contractor will be allowed to use EOT cranes of BHEL free of cost; however, slings, lifting tackles and manpower for operation shall be arranged by contractor. EOT cranes shall be operated by qualified operators only. Contractor to submit the list of crane operators & slingers to BHEL.

-
14. All the intermittent material movement i.e. handling of cut to size material, Raw material, finished goods, material movement during inspection, handing over of job to SR etc. shall be done by contractor.
 15. In contingency, in order to meet the job requirement, any additional resources if required shall be arranged by the contractor at their cost.
 16. Contractor may be required to work in 3 - Shifts. Contractor shall appoint supervisors for all Shifts for co-ordination with BHEL. Contractor to arrange adequate work force of experienced/qualified welders and fitters who should have good knowledge of reading BHEL Drawings and execute the job as per requirement of BHEL.
 17. To keep fabrication areas clean by doing complete housekeeping daily in all shifts. This responsibility will be totally of the contractor & failure in same will entail suitable action against him.
 18. Contractor must deploy manpower as per shop requirement. In case of failure to deploy required manpower suitable action shall be taken and suitable deduction also will be made from bills.
 19. Contractor shall be responsible for loss of tools, instruments & as deemed fit recovery for loss/damage shall be made from contractor's bill.
 20. BHEL try to maintain the work flow on regular basis. However, BHEL shall not bind to provide work regularly.
 21. The work shall be measured in terms of weight (Kilogram) for complete assembly cleared by BHEL- QC. The weight for payment shall be taken as per drawing only.
 22. The payment shall be made after fabrication of complete assemblies as per above scope of work & duly cleared by BHEL-QC on monthly basis.
 23. Contractor should not subcontract the work to other contractor.
 24. In the event of contractor abandoning the work or delay in execution of work or denial to do the work, BHEL reserves the right, to get the unfinished work completed at contractor's risk and cost.

D. SAFETY AT WORK PLACE:

1. Safety at work place is complete responsibility of the contractor. Contractor to depute one safety supervisor to take care of safety of their workmen. A weekly report on safety in appropriate format shall be submitted to BHEL.
2. Personnel Protective Equipments (PPEs) e.g. Leather Hand-Gloves, Safety-shoes, Helmets, Leg guards, Apron, Face Shield, Respirators, Safety Belts, Dungarees, Welding shields, masks, ear-buds, muffs gloves etc. (as per applicability) are to be arranged by the Contractor for their all workmen, as applicable.
3. All Contractor's workmen shall abide by the rules & regulations of BHEL with respect to Safety, Health and Environment while inside BHEL factory:
 - i. BHEL's HSE policy shall be honoured at all times.
 - ii. PPEs shall be used as required at the work-place.
 - iii. No unsafe act shall be indulged-in, by the workmen.

- iv. Special written permission for working at heights shall be obtained by contractor.
- v. Smoking & consumption of intoxicating substances is prohibited at all times inside factory.
- vi. All stipulations of the Factories Act shall be honoured and observed by contractor & workmen.

E. DELIVERY TERMS:

1. Contractor is required to deliver the assemblies as per following delivery schedule:

Sr. No.	One Set of Bowl Mill sub-assembly	Qty. to be delivered	Wt. of sub-assembly in MT	Delivery Period from date of issue of material
1	Separator Body	1	18.28	2 (Two) Months
2	Separator Top Static/Dynamic	1	16.45/5.42	
3	Mill side Housing	1	20.02	

- 2. The date of material issue as per issue voucher/register shall be treated as start of delivery of set. BOI items & other small components which can be cut by PUG machines/Gas cutting Torches shall not be considered in date of issue of material.
- 3. The delivery period includes time involved in material collection, fabrication, assembly, QC clearance and handing over of finished goods to BHEL.
- 4. If there is any delay attributed to BHEL in issuance of material, inspection clearance from customer etc., it is to be recorded clearly in the relevant documents and the equivalent increase in delivery time would be added to final delivery date calculation.
- 5. The assembly wise handing over note to dispatch section shall be treated as delivery of items and the same shall be used for payment as well as LD calculation.

F. QUALIFYING CRITERIA:

Sl. No.	Description of Qualifying requirement	Documentary Proof enclosed
A. Pre-Qualification Requirements:		
1.	Contractor should have experience of having successfully completed Fabrication works involving RT/UT of welding Joints during last 7 years ending last day of month previous to the one in which applications are invited should be any of the following: (a) Three completed/executed works each costing not less than the amount equal to 15 Lakhs. <div style="text-align: center;">OR</div> (b) Two completed/executed works each costing not less than the amount equal to 19 Lakhs. <div style="text-align: center;">OR</div> (c) One completed/executed work costing not less than the amount equal to 30 Lakhs. Copy of such work orders and performance report/completion certificate/inspection clearance report/other equivalent document issued by customer for successful execution of the order is to be submitted. In case of experience in private sector, TDS Certificate from customer shall	Yes/No

	also be furnished.	
2.	Average Annual Financial turnover during the previous 3 years, ending 31st March of the previous financial year should be Rs 12 Lakhs. Audited Profit & loss account and balance sheet to be submitted for FY 13-14, 12-13 and 11-12.	Yes/No
B. Technical Requirements:		
3.	Contractor should have minimum 5 nos. qualified welders duly approved from qualifying agency like NTPC, LLOYDS, BHEL, PDIL etc. (Certificates to be enclosed).	Yes/No
4.	Contractor should have minimum 5 nos. ITI/Experienced fitters (Certificates to be enclosed).	Yes/No

BHEL reserves the right to verify the documents submitted by the contractor.

In case the Tenderers not fulfilling the above conditions, the offer is liable for rejection. The semi filled, incomplete Tender Documents will be rejected.

TECHNO-COMMERCIAL DEVIATION SHEET

TENDER ENQUIRY NO & DATE:

WORK DESCRIPTION:

DUE DATE OF OPENING:

Mention any deviations from Tender enquiry if any, else mention "No deviation")

We hereby confirm that except for above, there are no other Deviation from all terms and conditions mentioned in Tender documents.

Signature of Authorized

Representative /Bidder

Designation:

Name:

Date:

Name of Organization

SECTION III

PRICE BID FORMAT

FORMAT-2

NIT No.: 0 0 0 0 0 0 0 0 0 0 .

Bidder should quote price bid in following format only:-

Sl. No	Work Description	Unit of Measurement	Rate quoted Rs. Per Unit
1	Fabrication and assembly of different types of bowl mill sub-assemblies as per drawing at Fabrication Plant, Jagdishpur as per scope of work.	Kg	

Service tax, if any: _____

Rate quoted (in words): _____

IMPORTANT:

1. Rates to be quoted in figures and words by the Contractor. There should not be any corrections in price bid contradictory to the above the offer will be liable for rejection.
2. The rate quoted should be kept **firm** during the execution of contract and no extra payment will be reimbursed to the contractor by BHEL. No increase in rate of DA / Wages hike shall be reimbursed to the Contractor. Contract shall anticipate such hike and quote in the tender.
3. Rate quoted above shall be inclusive of minimum wages as per govt. rules, **additional wages as per BHEL rules**, statutory requirements like PF & ESI, Uniform, shoes, PPEs, bonus, machinery charges, Consumable cost, supervision charges and all other charges as per scope of work exclusive of service tax. Service tax, if applicable shall be paid extra at actual.
4. L-1 bidder shall be decided on the basis of lowest rate quoted above.

(Signature and Seal of bidder)

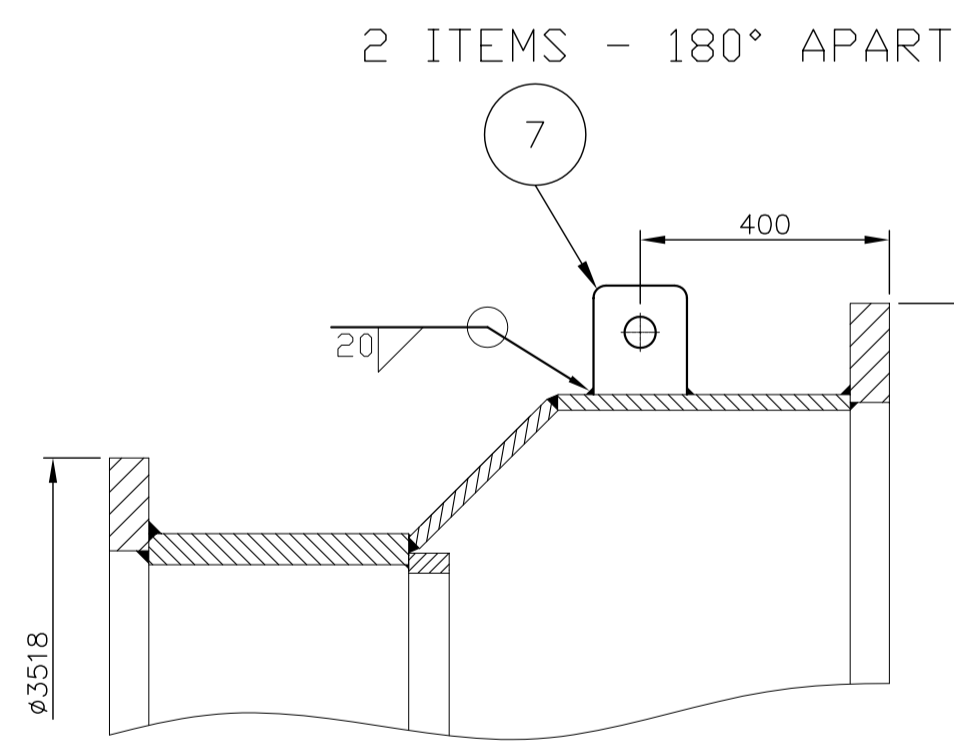
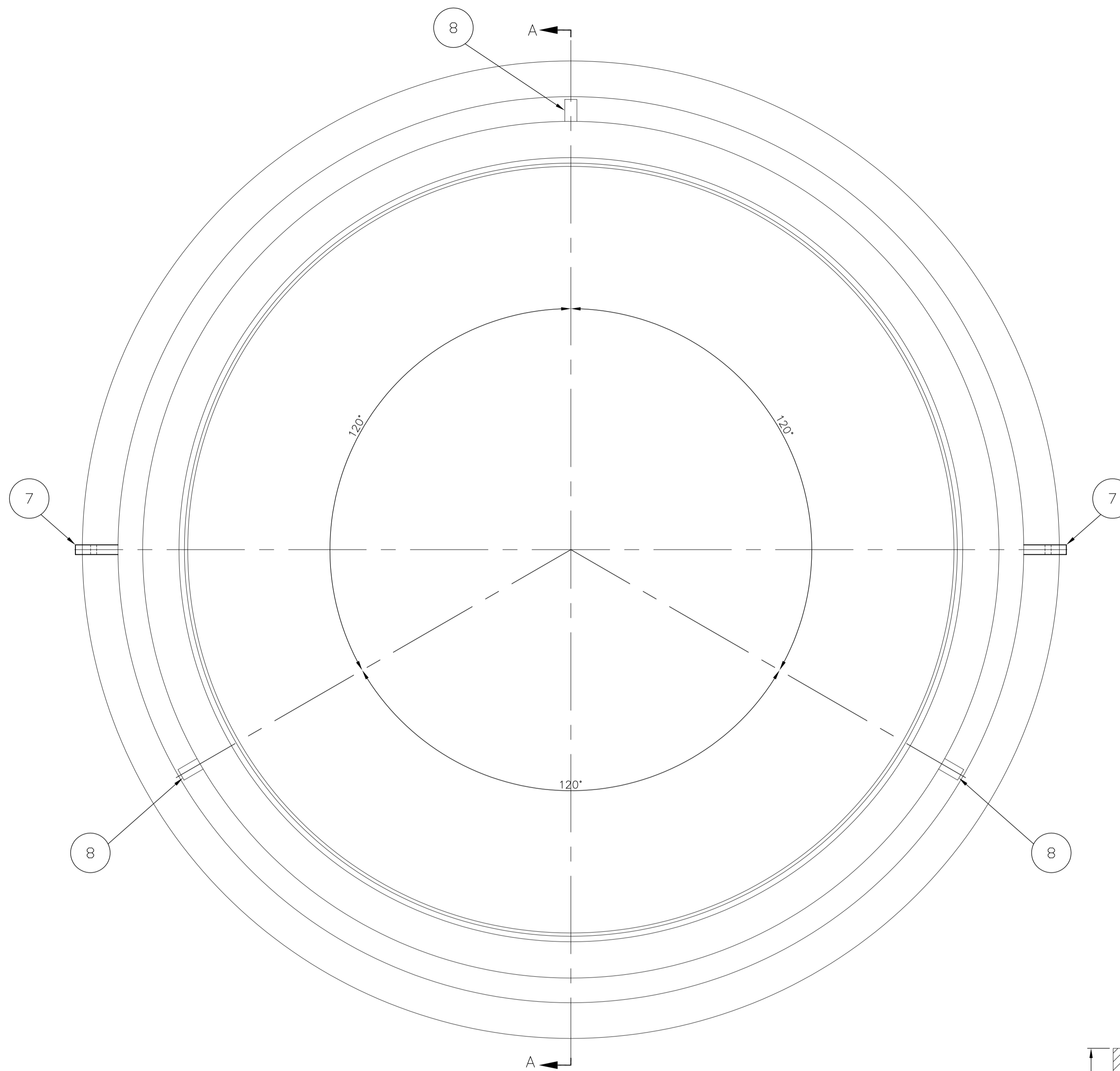
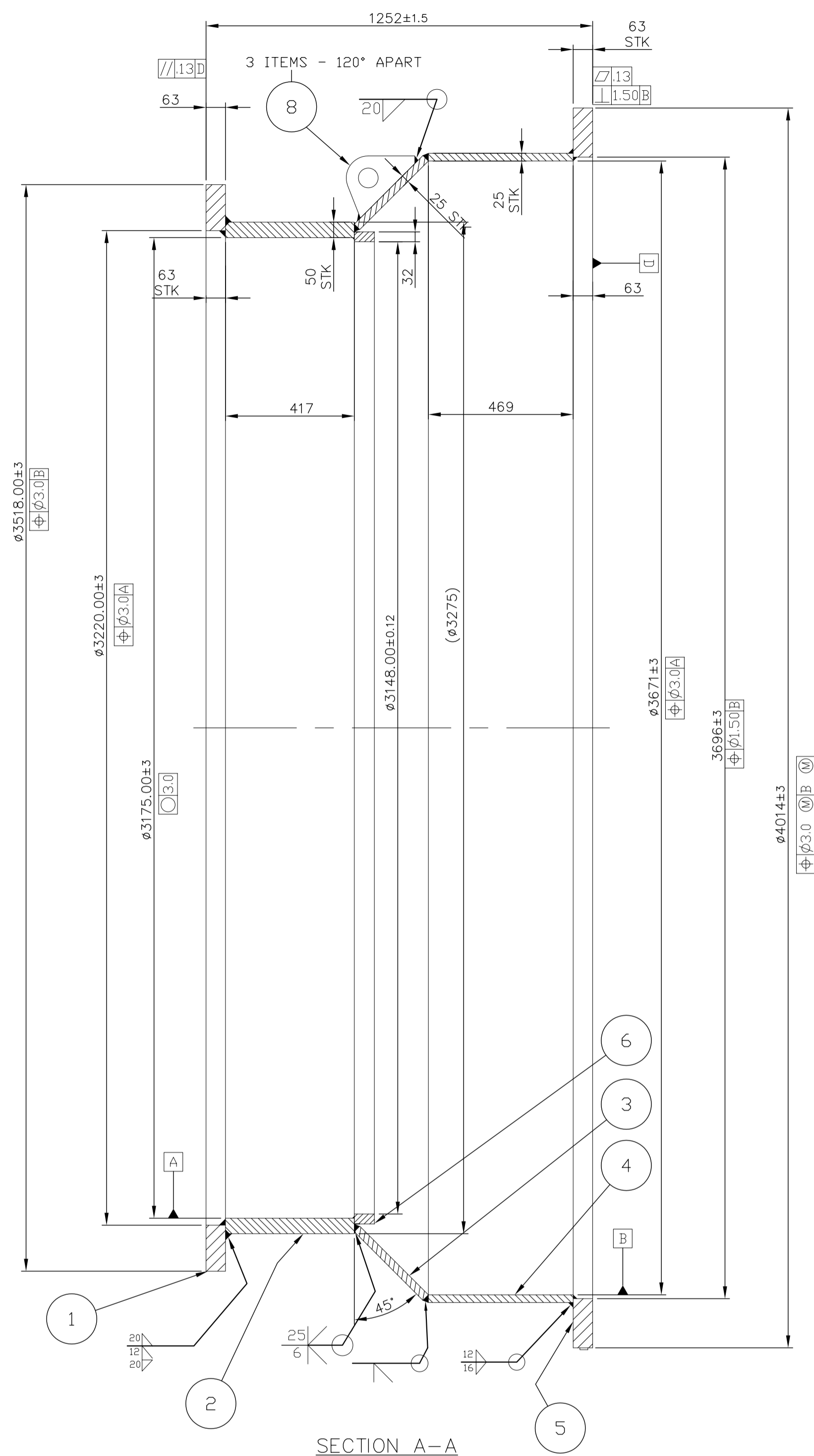

NOTES:

1. ALL BUTT WELDS TO BE OF FULL PENETRATION.
2. ALL WELDS SHALL BE IN ACCORDANCE WITH WPS NO. WE001.
3. THIS WELD SHALL BE MAGNA FLUX INSPECTED.
4. UNLESS OTHERWISE SPECIFIED ALL DIMENSIONS ARE IN MM.
5. ALL BUTT WELDS TO BE 10% SPOT RADIOGRAPHED (100% FOR KNOT) ACCEPTANCE AS PER HY0850170.
6. ALL BUTT WELDS TO BE LPI TESTED AFTER BACK CHIPPING AS PER AA0850131, ACCEPTANCE AS PER AA0850129.
7. ALL WELDS TO BE 100% LPI TESTED AS PER AA0850131. ACCEPTANCE AS PER AA0850129.
8. TRANSPORT (FABRICATED SEP. TOP) WITH LARGER FLANGE (05) RESTING ON THE TRUCK. (SEE FIG BELOW)
9. HEAT TREATMENT OF THE SEP TOP WITH LARGER FLANGE (05) ON THE FURNACE TROLLEY.

1	SEPARATOR TOP-FAB ITEMS (DYNAMIC CLASSIFIER)	0-61-310-00891			5419.44	6572.24
ITEM NO.	DESCRIPTION	DRAWING NO.	VAR. NO.	RAW MATERIAL SIZE OR CASTING DRG. NO. OR FORGING DRG. NO.	MATERIAL CODE	NET WT. GROSS WT.
					MATERIAL SPECN.	QUANTITY

THE FOLLOWING CONDITIONS APPLY EXCEPT OTHERWISE STATED.

1. REF. TO HY0230261 FOR UNSPECIFIED TOLERANCES.
2. CHAMFER M/C.D. SHARP EDGES AT 45°.
3. INTERNAL M/C.D. CORNER RADII 1 TO 0.7
4. THE SURFACE ROUGHNESS WHERE-EVER NOT SHOWN SHALL BE TAKEN FROM THE SURFACE ROUGHNESS SHOWN OUT SIDE THE BACK SLASH GIVEN OR THE TOP MOST RIGHT CORNER OF THE DRG.

TYPE OF PRODUCT HP-1103 BOWL MILL
NAME OF CUSTOMER/PROJECT

DRN. ASHOK REDDY	SIGN.	DATE 10.10.12	NO. OF VAR.
CHD. AMAN		10.10.12	
APPD. S.GHATGE		10.10.12	

DEPT. 446	UNTL. DIMS. GR. 2/M/F	SCALE NTS	WEIGHT (KG) 5419.44	REF. TO ASSY DRG.	ITEM NO.	NO. OF ITEMS
-----------	-----------------------	-----------	---------------------	-------------------	----------	--------------

TITLE SEPARATOR TOP (FAB) FOR DYNAMIC CLASSIFIER	CARD CODE	DRAWING NO. 1-61-310-01846	REV. 01
		SHEET NO. 01	NO. OF SHEETS 01

REV.	DATE	ALTERED CHD./APPD.	REV.	DATE	ALTERED CHD./APPD.	REV.	DATE	ALTERED CHD./APPD.
01	09.04.12							
1. TIMING BAR (ITEM-07) 4-61-320-03421) REMOVED. 2. LUGS (ITEM-07 & 08) ADDED. 3. SECTIONING-C ADDED. 4. SECTIONING-A & TOP VIEW MODIFIED. 5. NOTES ADDED. 6. NET & GROSS WTS MODIFIED ACCORDINGLY.								

THE INFORMATION ON THIS DOCUMENT IS THE PROPERTY OF BHARAT HEAVY ELECTRICALS LIMITED. IT MUST NOT BE USED DIRECTLY OR INDIRECTLY IN ANY WAY DETRIMENTAL TO THE INTEREST OF THE COMPANY

COMPUTER FILE NAME

INVENTORY NO. SIGN. AND DATE REF. DRG. NO.

07600-01C-19-0 DN 098

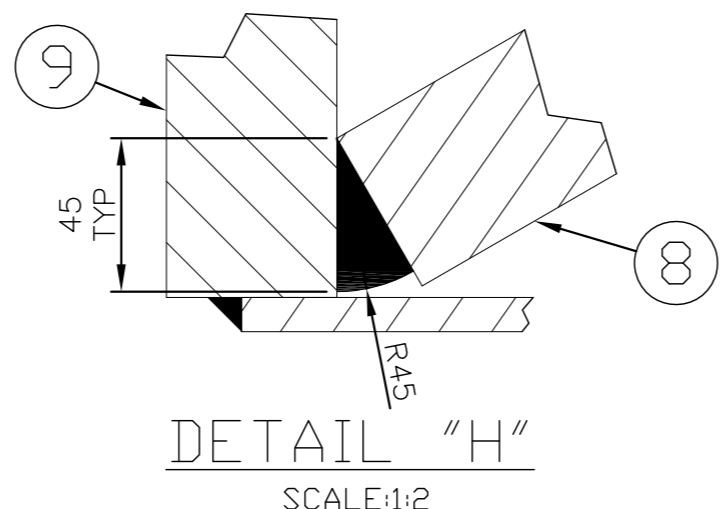
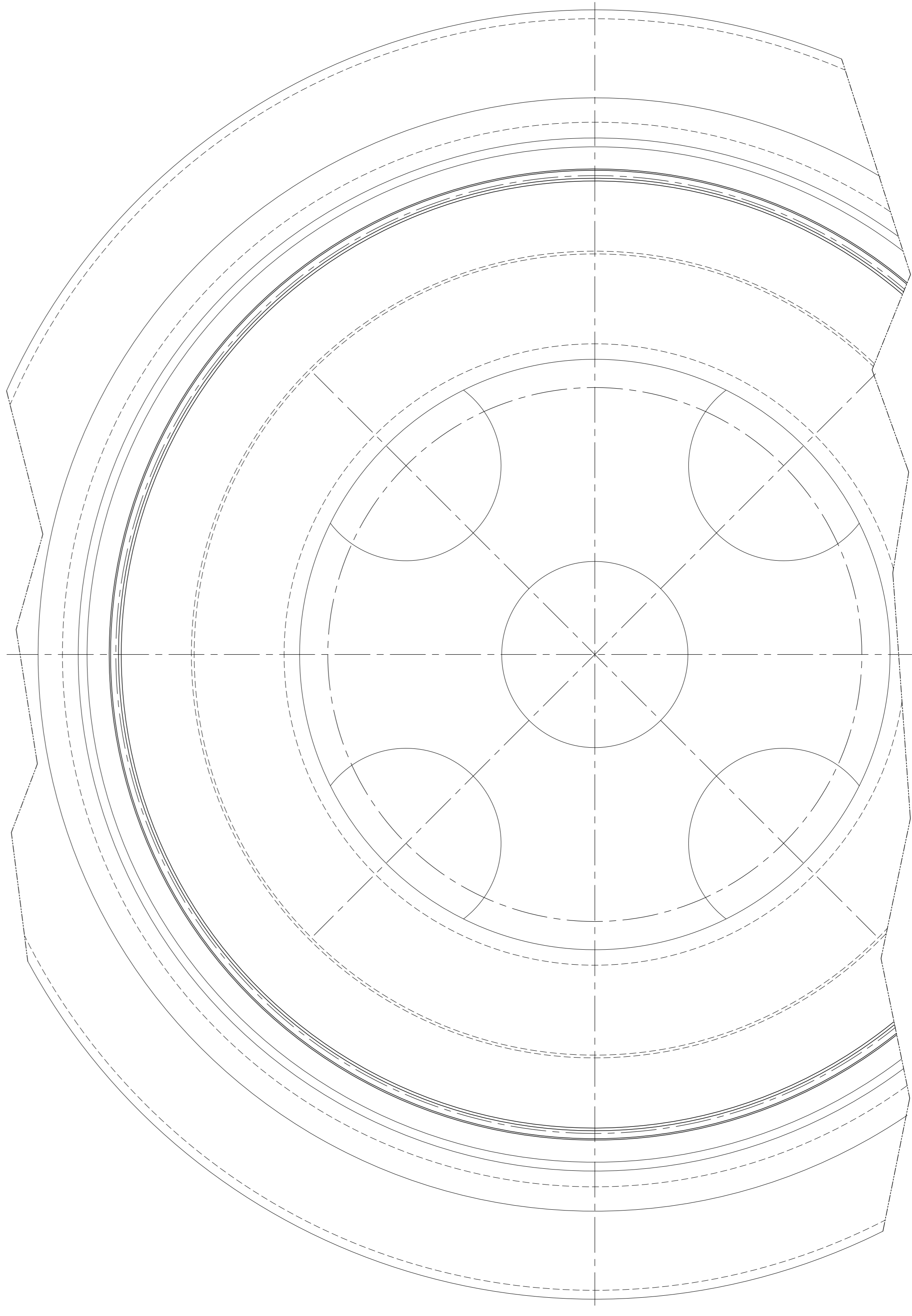
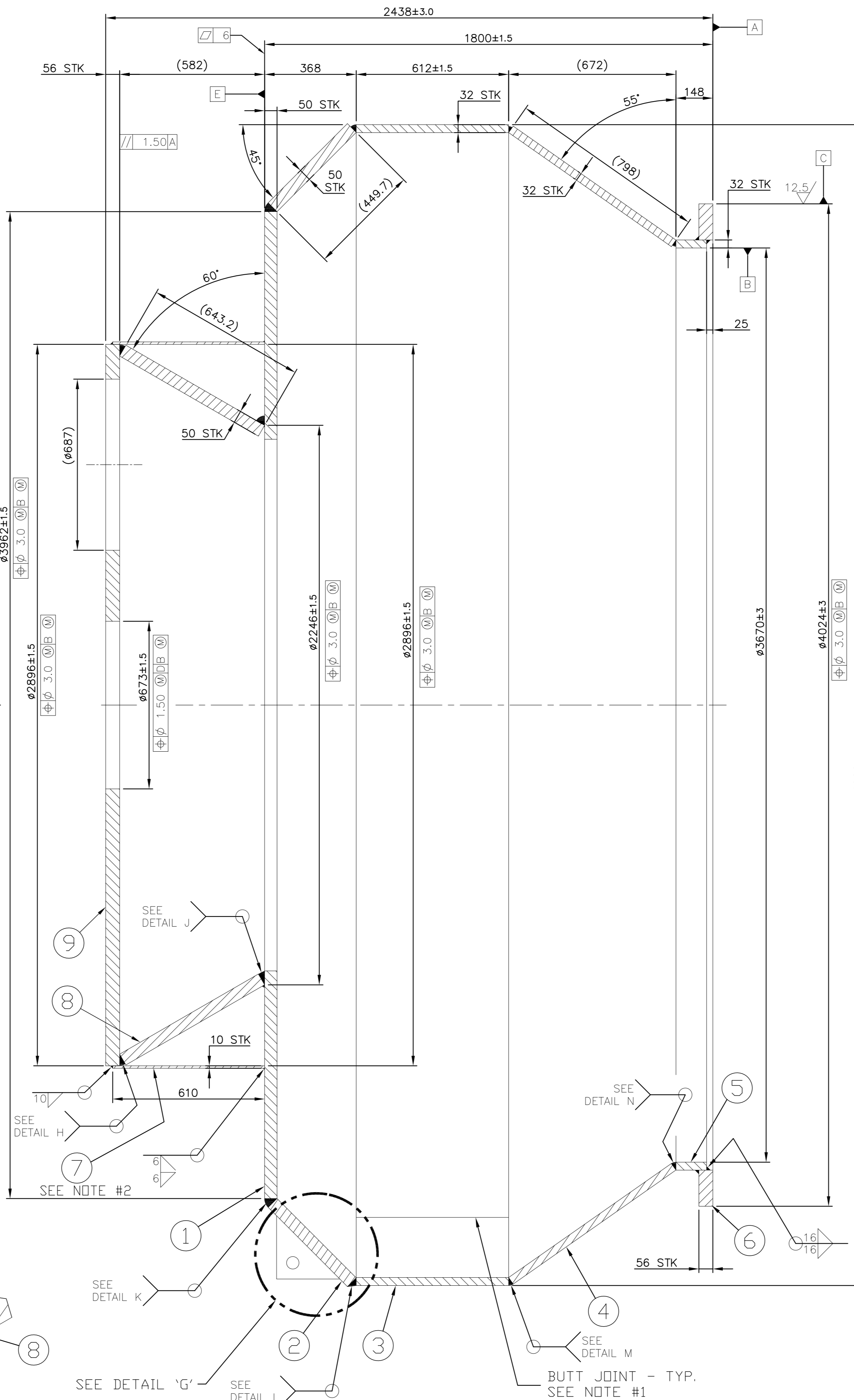
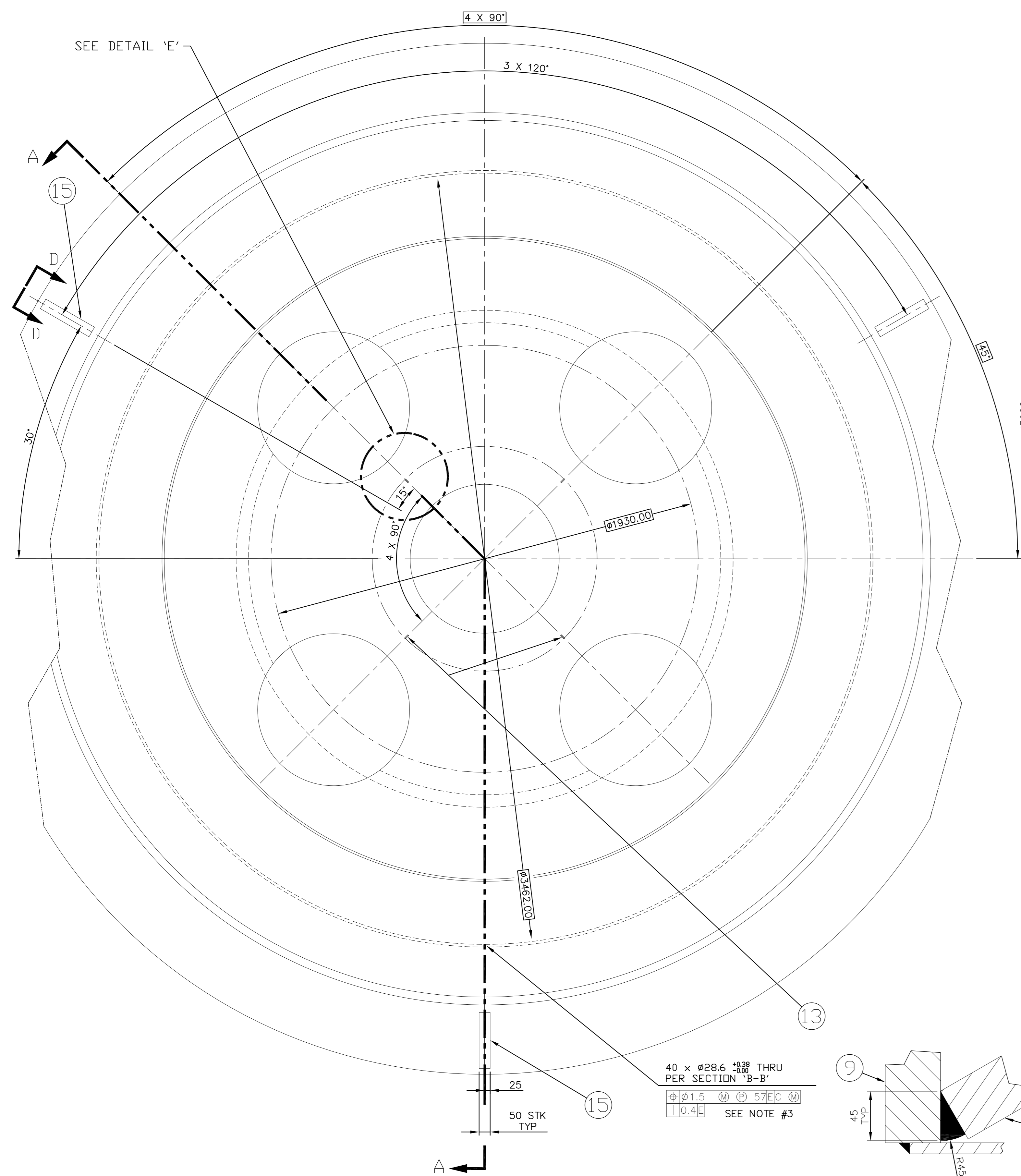

SECTION "A-A"

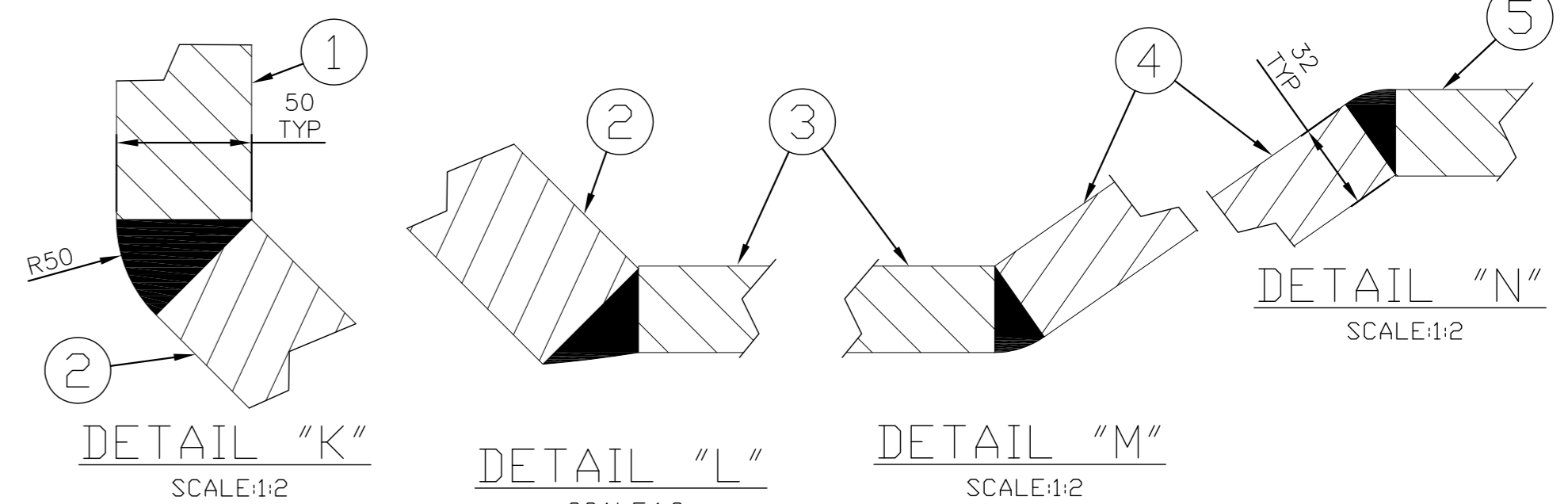

- NOTES:**
- BUTT JOINTS TO BE MADE WITH FULL STRENGTH WELDS. ALL WELDS SHALL BE IN ACCORDANCE WITH WPS NO. WE001.
 - THIS WELD SHALL BE MAGNA FLUX INSPECTED.
 - UNLESS OTHERWISE SPECIFIED ALL DIMENSIONS ARE IN MM.
 - ALL BUTT WELDS TO BE 10% SPOT RADIOGRAPHED (100% FOR KNOT) ACCEPTANCE AS PER HY0850170.
 - ALL BUTT WELDS TO BE LPI TESTED AFTER BACK CHIPPING AS PER AA0850131, ACCEPTANCE AS PER AA0850129.
 - ALL WELDS TO BE 100% LPI TESTED AS PER AA0850131, ACCEPTANCE AS PER AA0850129.
 - TRANSPORT (FABRICATED SEP. TOP) WITH LARGER FLANGE (06) RESTING ON THE TRUCK. (SEE FIG BELOW)
 - HEAT TREATMENT OF THE SEP TOP WITH LARGER FLANGE (06) ON THE FURNACE TROLLEY.

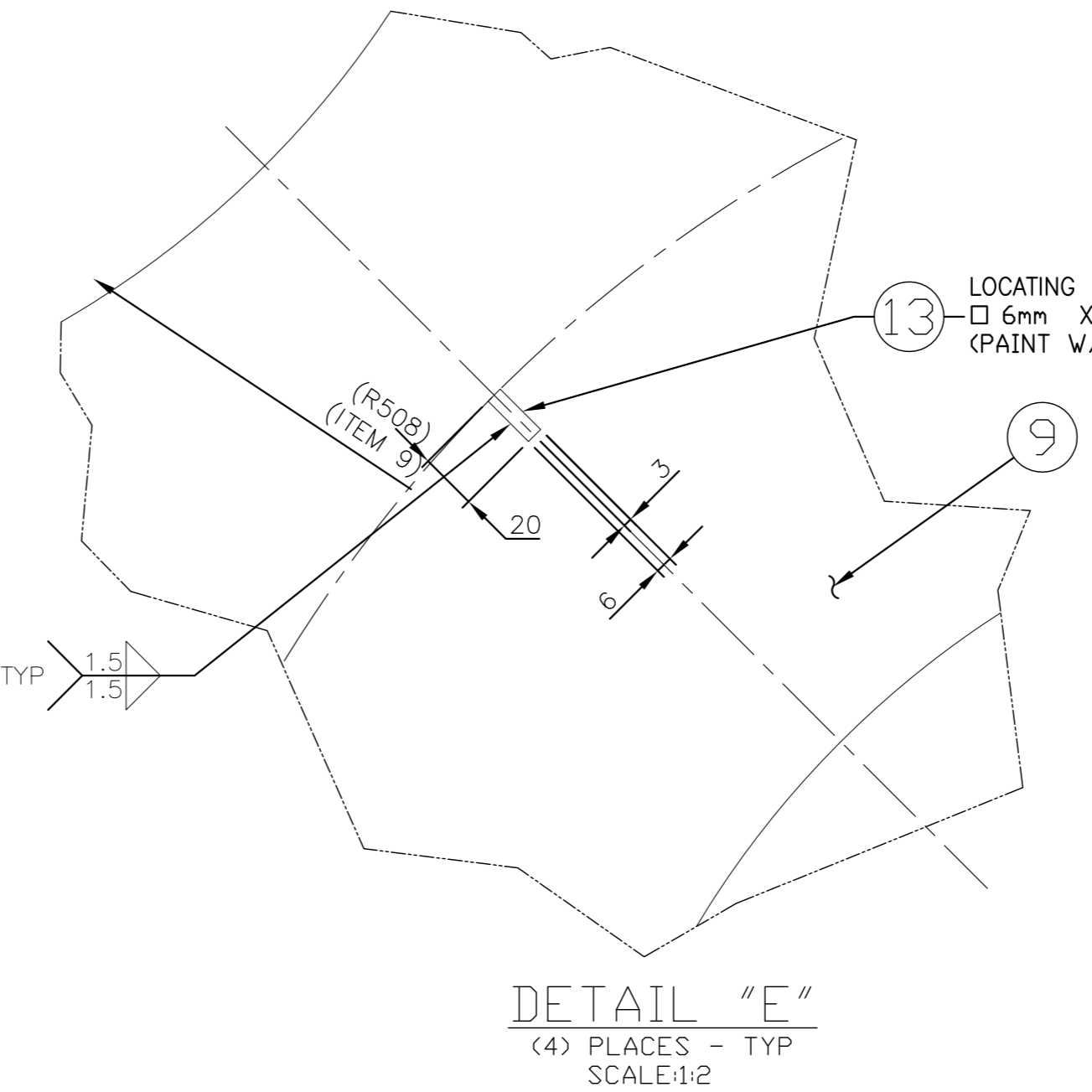
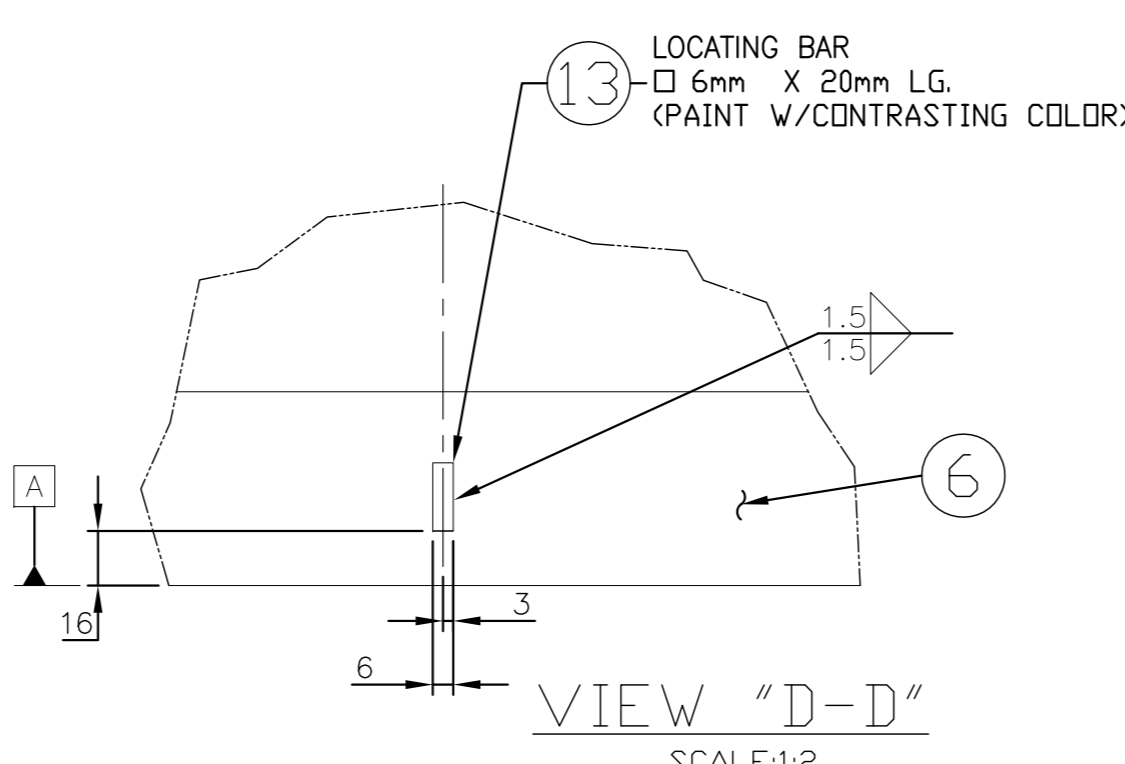
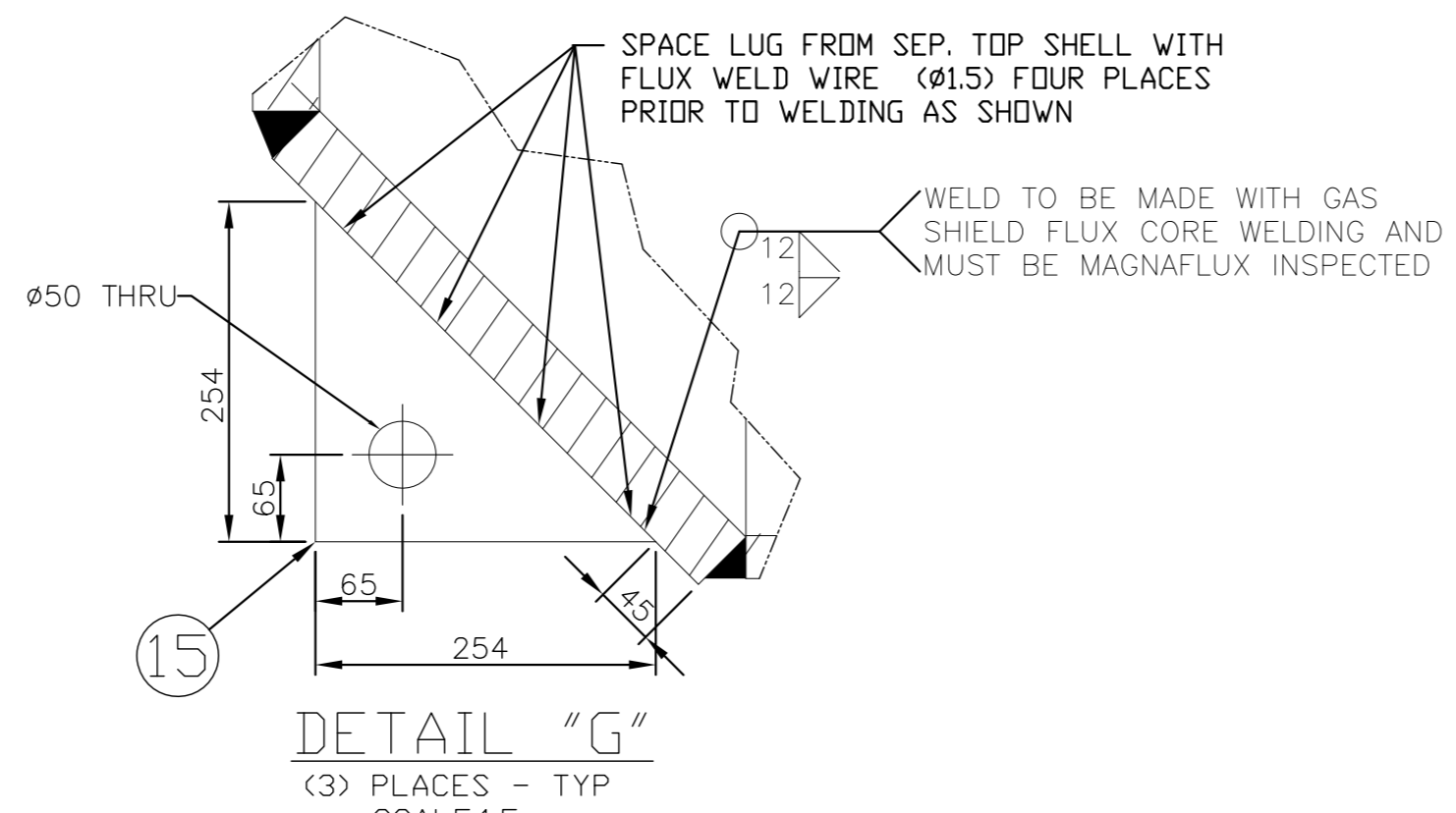

THIRD ANGLE PROJECTION

TOTAL GROSS WT: 23306 KG

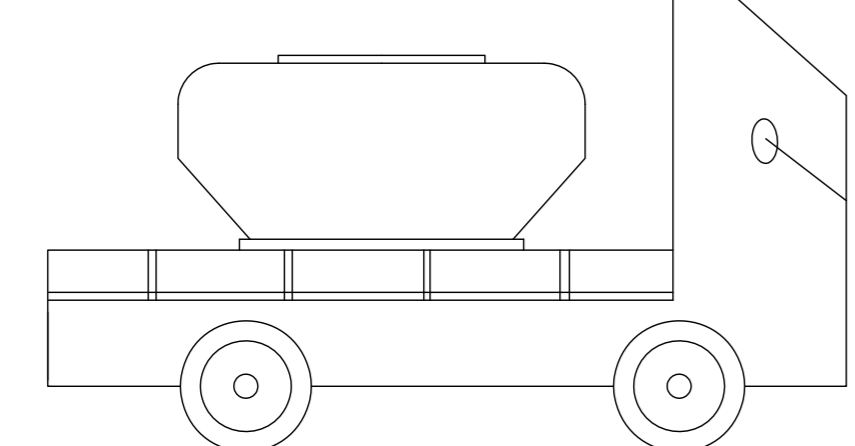

THIS DWG. DOES NOT CONTAIN ALL INFORMATION NECESSARY FOR MFG. THIS PART. REFER TO RELEVANT PURCHASE SPECIFICATIONS & BILL OF MATERIALS FOR COMPLETE IDENTIFICATION & PROCESSING.

ITEM NO.	DESCRIPTION	DRAWING NO.	VAR. NO.	RAW MATERIAL SIZE OR CASTING DRG. NO. OR FORGING DRG. NO.	MATERIAL CODE	NET WT.	GROSS WT.	QUANTITY
05	REVISED FOR EDAS UPDATION.	07.10.14	SHARIFF	AMAN	S.GHATGE			
02	NET WT WAS 16450.	10.06.14	SHARIFF	AMAN	S.GHATGE			
03	NET WT WAS 16450.	07.09.14	SHARIFF	AMAN	S.GHATGE			
02	WELD DETAILS - J, L, M & N MODIFIED	10.06.14	SHARIFF	AMAN	S.GHATGE			
01	SECTION - F-F & ITEM-12 REMOVED	09.01.14	SHARIFF	AMAN	S.GHATGE			

REV.	DATE	ALTERED	CHECKED	APPROVED	REV.	DATE	ALTERED	CHECKED	APPROVED	REV.	DATE	ALTERED	CHECKED	APPROVED	REV.	DATE	ALTERED	CHECKED	APPROVED	REV.	DATE	ALTERED	CHECKED	APPROVED	
05	07.10.14				03	07.09.14				02	10.06.14				01	09.01.14									

ITEM NO.	DESCRIPTION	DRAWING NO.	VAR. NO.	RAW MATERIAL SIZE OR CASTING DRG. NO. OR FORGING DRG. NO.	MATERIAL CODE	NET WT.	GROSS WT.	QUANTITY
05	REVISED FOR EDAS UPDATION.	07.10.14	SHARIFF	AMAN	S.GHATGE			
02	NET WT WAS 16450.	10.06.14	SHARIFF	AMAN	S.GHATGE			
03	NET WT WAS 16450.	07.09.14	SHARIFF	AMAN	S.GHATGE			
02	WELD DETAILS - J, L, M & N MODIFIED	10.06.14	SHARIFF	AMAN	S.GHATGE			
01	SECTION - F-F & ITEM-12 REMOVED	09.01.14	SHARIFF	AMAN	S.GHATGE			

REV.	DATE	ALTERED	CHECKED	APPROVED	REV.	DATE	ALTERED	CHECKED	APPROVED	REV.	DATE	ALTERED	CHECKED	APPROVED	REV.	DATE	ALTERED	CHECKED	APPROVED	REV.	DATE	ALTERED	CHECKED	APPROVED
05	07.10.14				03	07.09.14				02	10.06.14				01	09.01.14								

ITEM NO.	DESCRIPTION	DRAWING NO.	VAR. NO.	RAW MATERIAL SIZE OR CASTING DRG. NO. OR FORGING DRG. NO.	MATERIAL CODE	NET WT.	GROSS WT.	QUANTITY
05	REVISED FOR EDAS UPDATION.	07.10.14	SHARIFF	AMAN	S.GHATGE			
02	NET WT WAS 16450.	10.06.14	SHARIFF	AMAN	S.GHATGE			
03	NET WT WAS 16450.	07.09.14	SHARIFF	AMAN	S.GHATGE			
02	WELD DETAILS - J, L, M & N MODIFIED	10.06.14	SHARIFF	AMAN	S.GHATGE			
01	SECTION - F-F & ITEM-12 REMOVED	09.01.14	SHARIFF	AMAN	S.GHATGE			

REV.	DATE	ALTERED	CHECKED	APPROVED	REV.	DATE	ALTERED	CHECKED	APPROVED	REV.	DATE	ALTERED	CHECKED	APPROVED	REV.	DATE	ALTERED	CHECKED	APPROVED	REV.	DATE	ALTERED	CHECKED	APPROVED
05	07.10.14				03	07.09.14				02	10.06.14				01	09.01.14								

ITEM NO.	DESCRIPTION	DRAWING NO.	VAR. NO.	RAW MATERIAL SIZE OR CASTING DRG. NO. OR FORGING DRG. NO.	MATERIAL CODE	NET WT.	GROSS WT.	QUANTITY
05	REVISED FOR EDAS UPDATION.	07.10.14	SHARIFF	AMAN	S.GHATGE			
02	NET WT WAS 16450.	10.06.14	SHARIFF	AMAN	S.GHATGE			
03	NET WT WAS 16450.	07.09.14	SHARIFF	AMAN	S.GHATGE			
02	WELD DETAILS - J, L, M & N MODIFIED	10.06.14	SHARIFF	AMAN	S.GHATGE			
01	SECTION - F-F & ITEM-12 REMOVED	09.01.14	SHARIFF	AMAN	S.GHATGE			

REV.	DATE	ALTERED	CHECKED	APPROVED	REV.	DATE	ALTERED	CHECKED	APPROVED	REV.	DATE	ALTERED	CHECKED	APPROVED	REV.	DATE	ALTERED	CHECKED	APPROVED	REV.	DATE	ALTERED	CHECKED	APPROVED
05	07.10.14				03	07.09.14				02	10.06.14				01	09.01.14								

ITEM NO.	DESCRIPTION	DRAWING NO.	VAR. NO.	RAW MATERIAL SIZE OR CASTING DRG. NO. OR FORGING DRG. NO.	MATERIAL CODE	NET WT.	GROSS WT.	QUANTITY
05	REVISED FOR EDAS UPDATION.	07.10.14	SHARIFF	AMAN	S.GHATGE			
02	NET WT WAS 16450.	10.06.14	SHARIFF	AMAN	S.GHATGE			
03	NET WT WAS 16450.	07.09.14	SHARIFF	AMAN	S.GHATGE			
02	WELD DETAILS - J, L, M & N MODIFIED	10.06.14	SHARIFF	AMAN	S.GHATGE			
01	SECTION - F-F & ITEM-12 REMOVED	09.01.14	SHARIFF	AMAN	S.GHATGE			

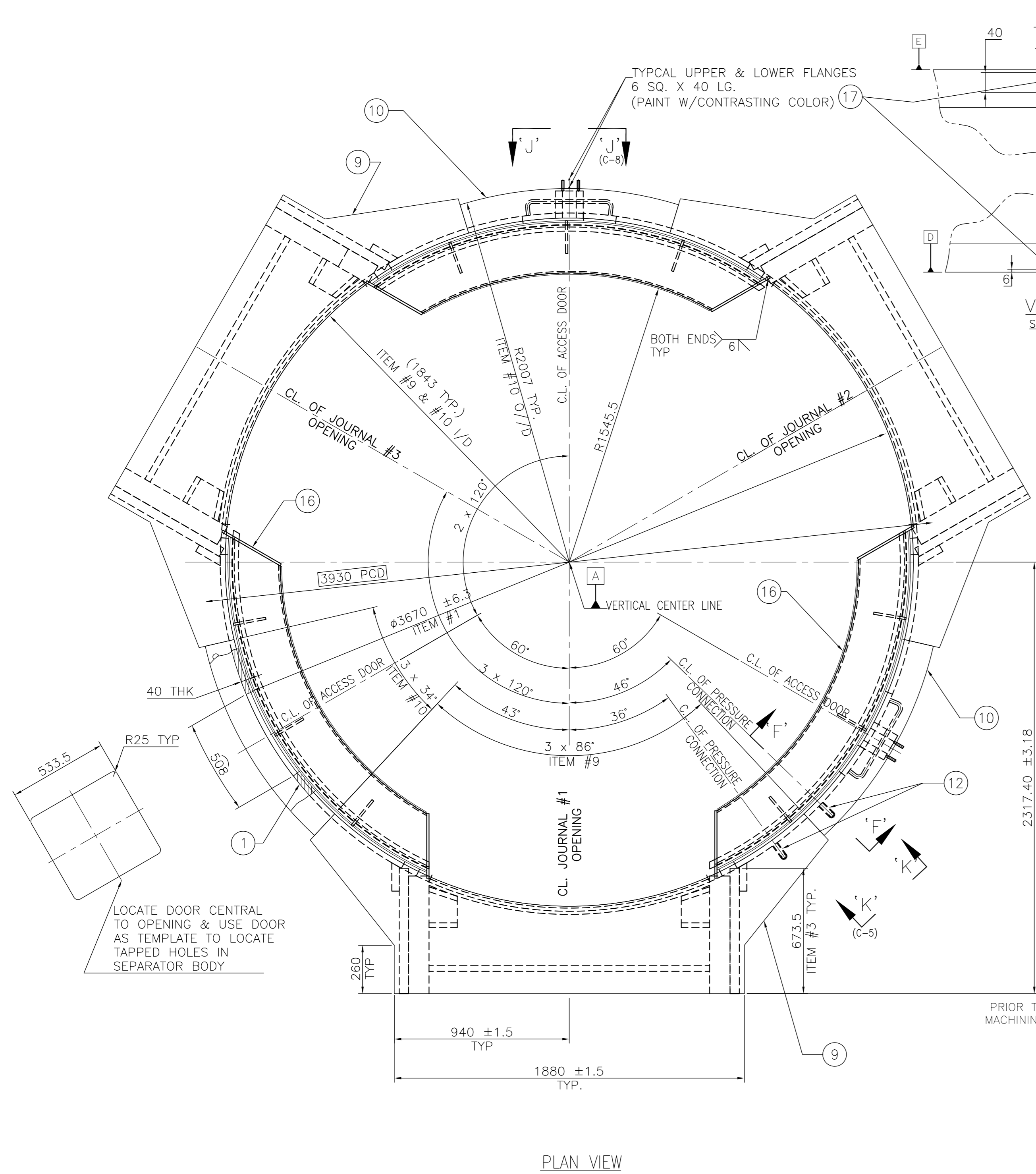

PLAN VIEW

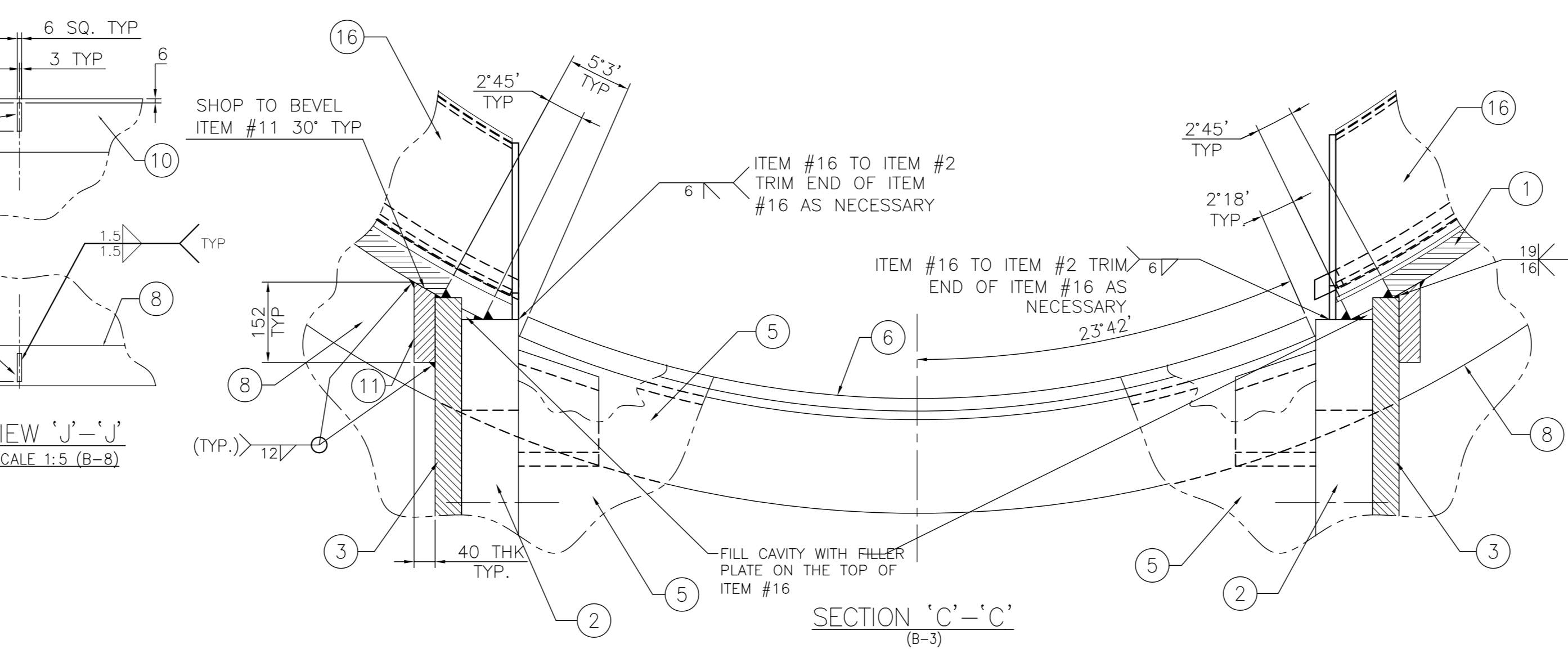

SECTION 'C-C' (B-3)

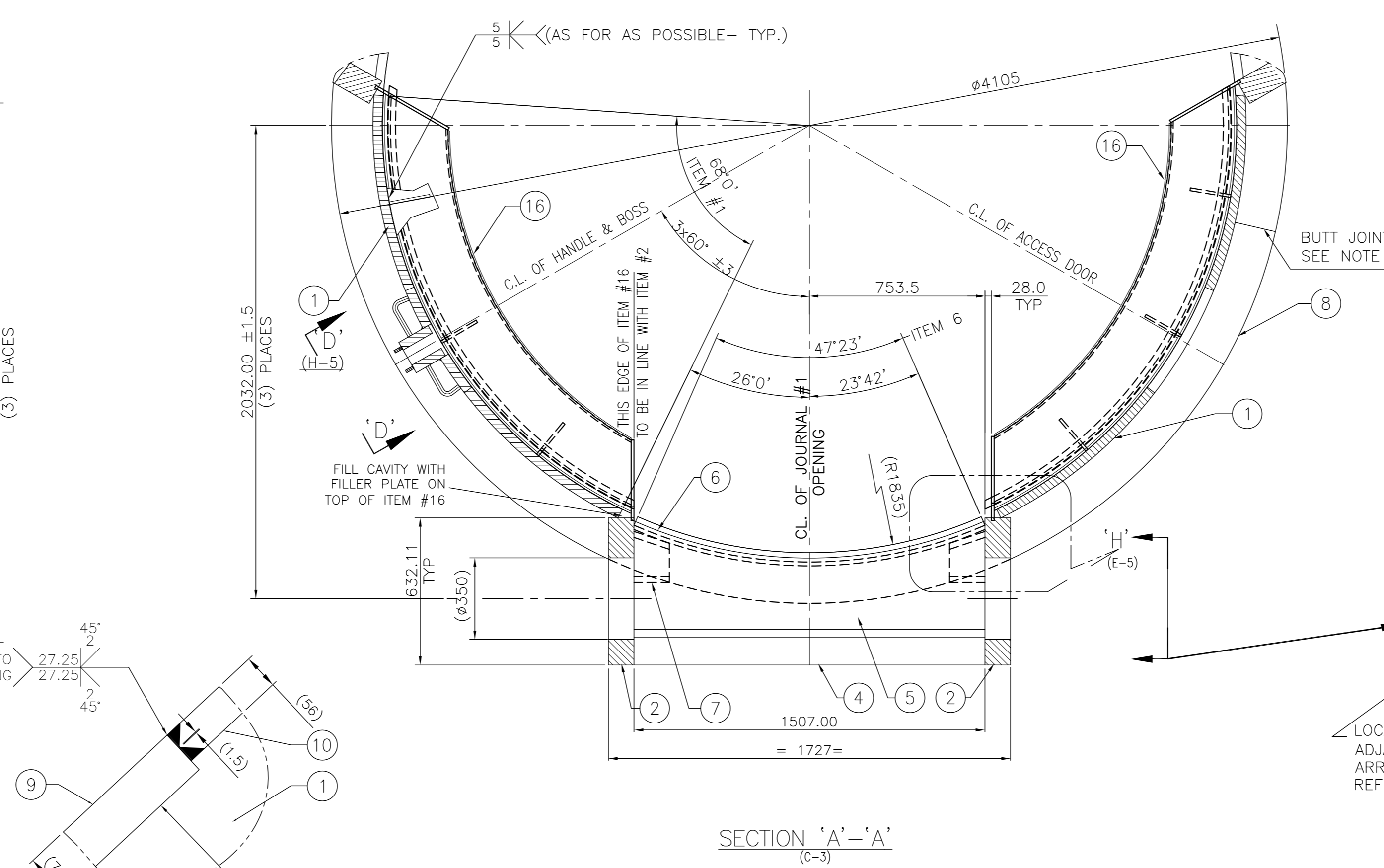

SECTION 'A-A' (C-3)

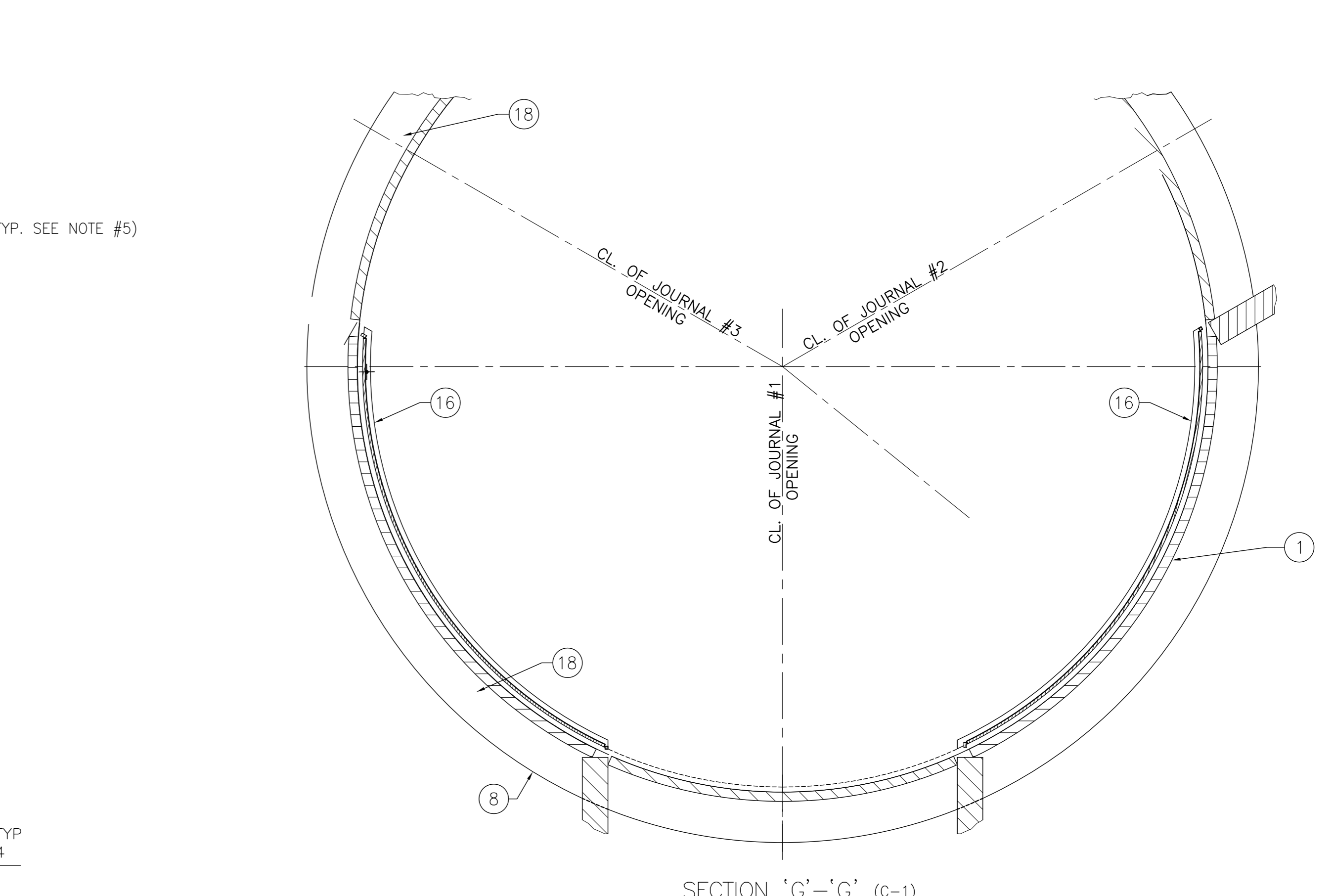

SECTION 'G-G' (C-1)

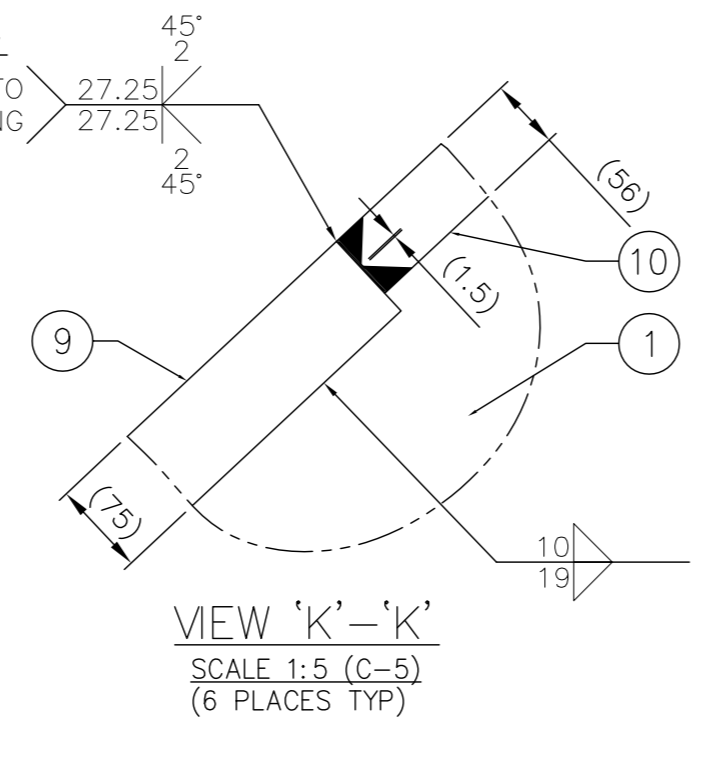

VIEW 'K-K' (C-5)

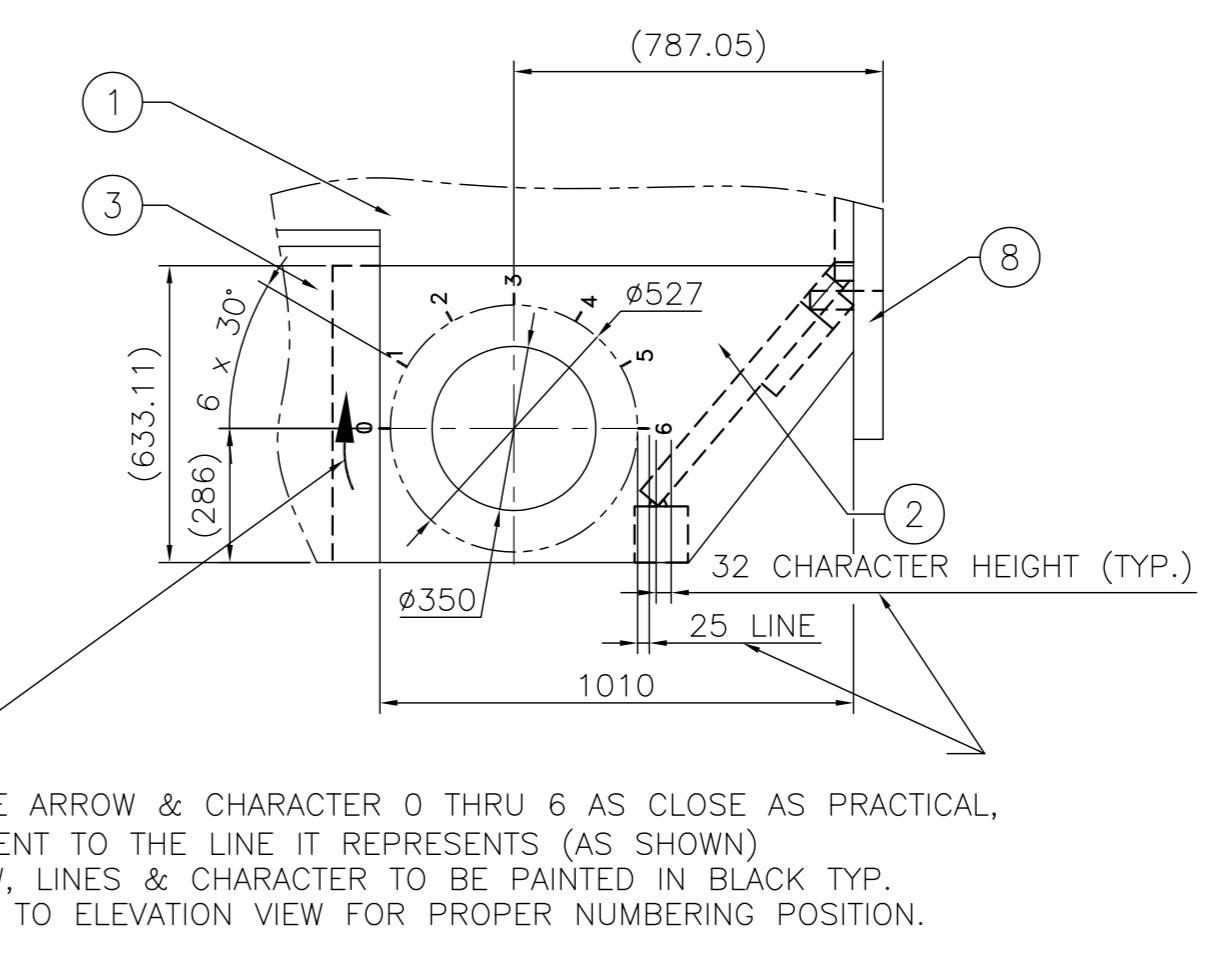

VIEW 'D-D' (D-5)

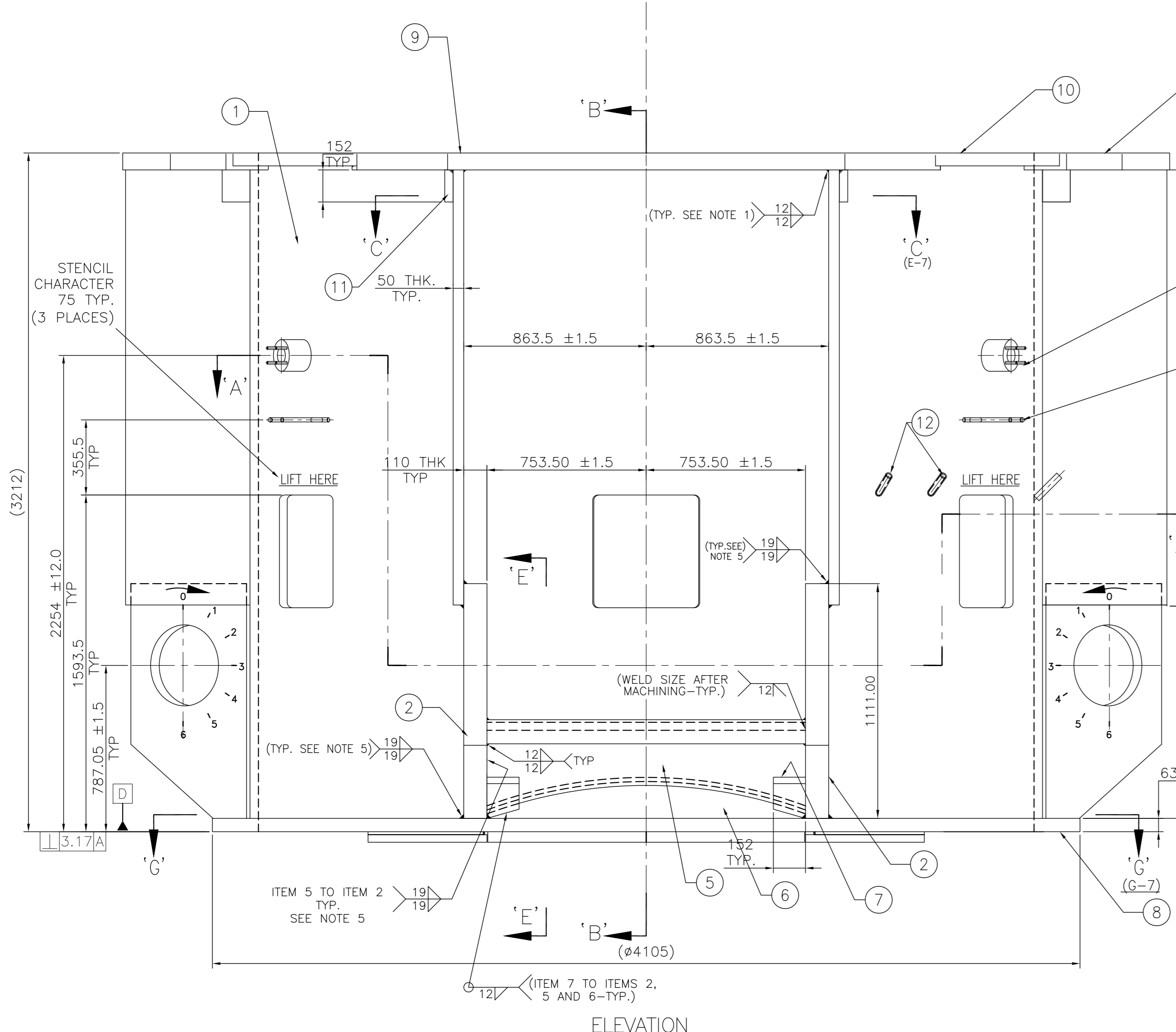

ELEVATION

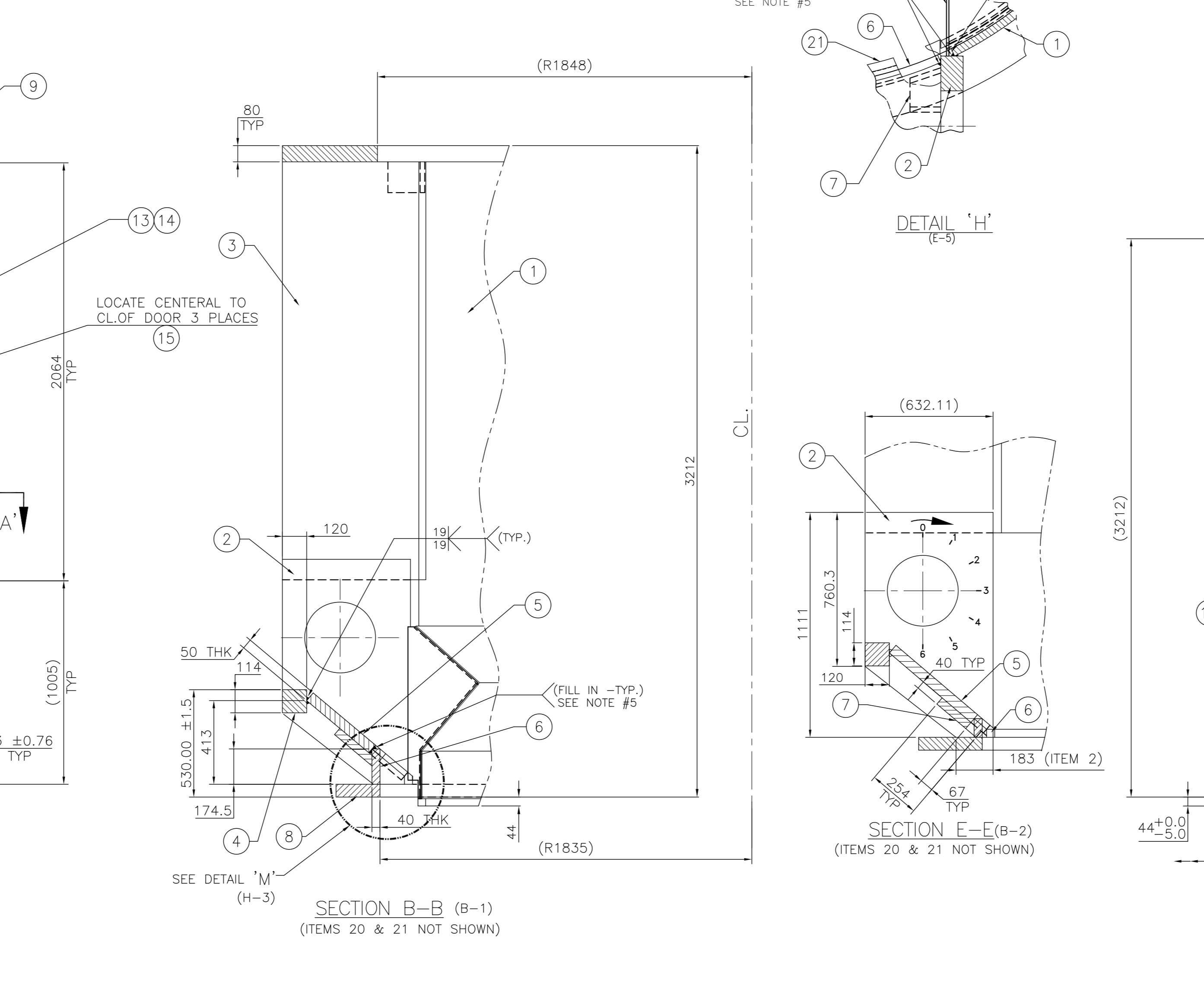

SECTION B-B (B-1) (H-3)

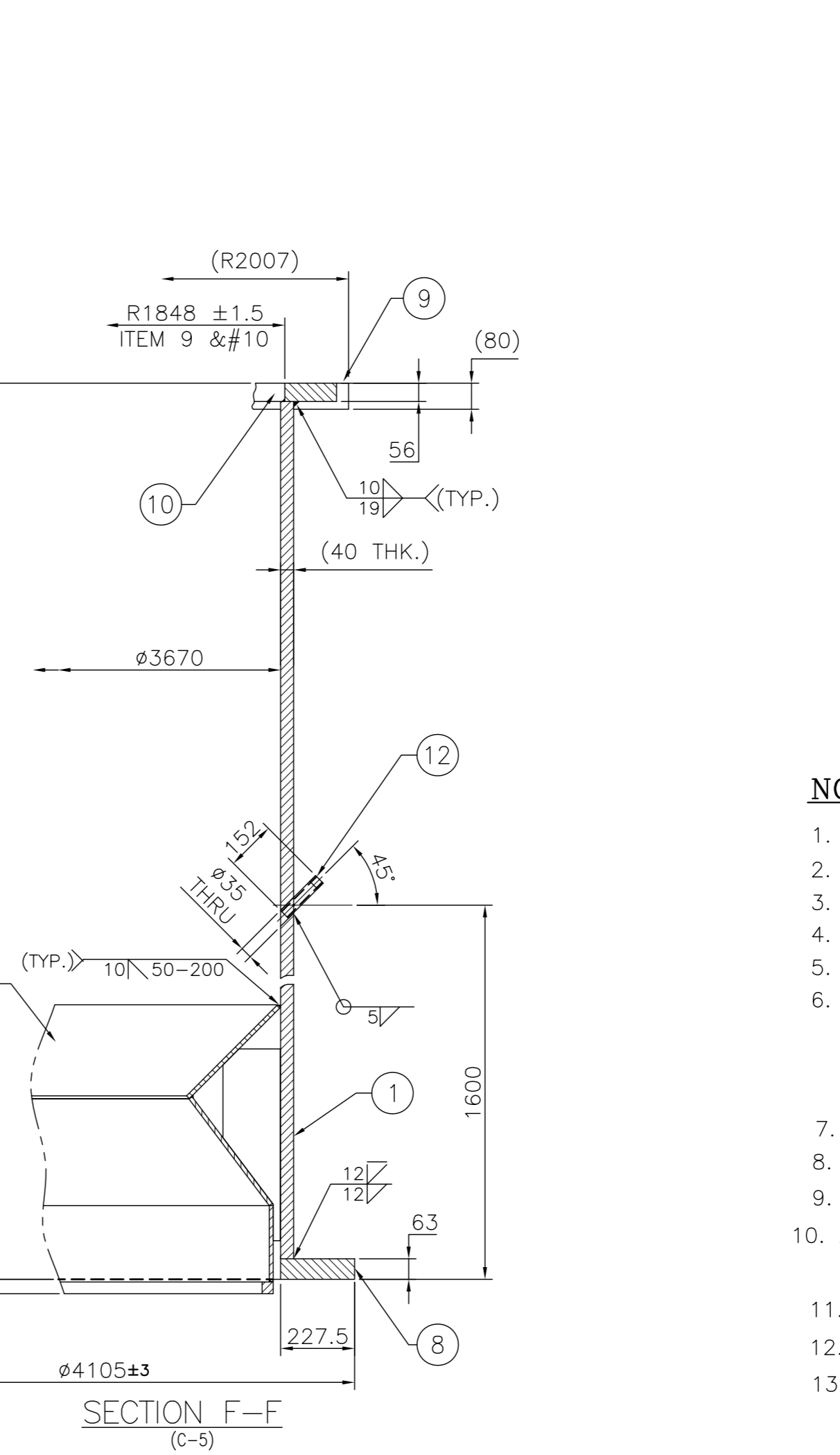

SECTION F-F (C-5)

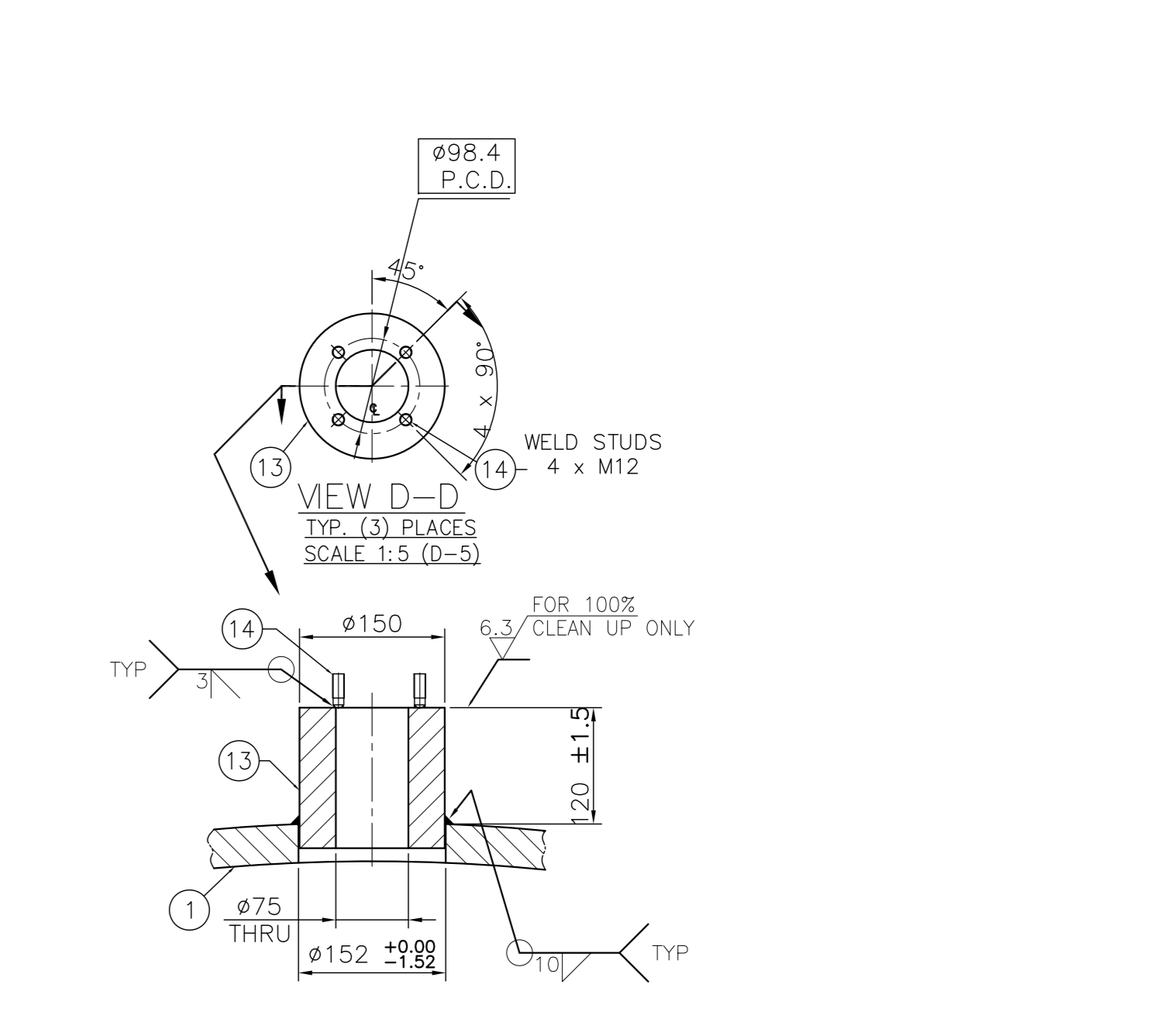

DETAIL 'M' (D-1)

- NOTES:-**
- THIS WELD MUST BE MAGNETIC PARTICLE INSPECTED BEFORE MACHINING (TYP 12 PLACES).
 - USE DOOR FRAME (ITEM 4) AS A TEMPLATE FOR THE CUTTING OF DOOR FRAME OPENING
 - THIS WELD TO BE MADE WITH GAS SHIELDED FLUX CORE WELDING
 - ALL FILLET WELD TO BE 12L UNLESS OTHERWISE NOTED
 - ALL "V" WELDS TO BE FULL PENETRATION WELDS UNLESS OTHERWISE NOTED
 - ALL BUTT WELDS TO BE:
 - A) FULL PENETRATION "X" WELDS.
 - B) LPI TESTED AFTER BACK CHIPPING AS PER A40850131 ACCEPTANCE AS PER A40850129
 - C) 100% MINIMUM RADIOGRAPHY TESTED (100% FOR ALL KNOT WELDS) AS PER HY0850170.
 - LPI OF ALL FINISHED WELDS AS PER A40850131 AND ACCEPTANCE AS PER A40850129 .
 - REFER TO 0-61-310-00902 FOR MACHINING DRAWING.
 - NOTES 4 TO 7 ARE ALSO APPLICABLE FOR PART DRAWINGS REFERRED TO IN THIS DRAWING
 - ABOVE ARE MINIMUM NDT REQUIREMENTS. CUSTOMER APPROVED QUALITY PLAN MAY REQUIRE ADDITIONAL NDT REQUIREMENT / PERCENTAGE
 - FOR LOCATION OF ITEM 16 SEE SECTIONS A-A, C-C AND F-F.
 - WELD ITEMS #1 THRU #15 AS SHOWN.
 - REFER 06131000935 DRAWING FOR CUTTING PLANS

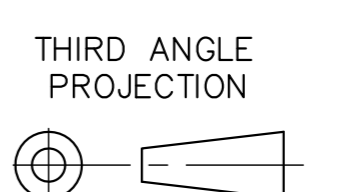

THIRD ANGLE PROJECTION

THE FOLLOWING CONDITIONS APPLY EXCEPT OTHERWISE STATED.		TYPE OF PRODUCT NAME OF CUSTOMER/PROJECT		HP 1103 BOWL MILL	
1. REF. TO HY0230261 FOR UNSPECIFIED TOLERANCES.	2. CHAMFER M/C/D. SHARP EDGES AT 45°.	3. INTERNAL M/C/D. CORNER RADI 1 TO 0.7	4. THE SURFACE ROUGHNESS WHERE-EVER NOT SHOWN SHALL BE TAKEN FROM THE SURFACE ROUGHNESS SHOWN OUT SEE THE BACK SLASH GIVEN OR THE TOP MOST RIGHT CORNER OF THE DRG.	NAME BHARAT HEAVY ELECTRICALS LIMITED HYDERABAD	DATE 26.10.13
DRN BKG	CHK AMAN	APPD S.G.HATGE	SCALE 1:16	WEIGHT (KG) 18284	REF. TO ASSY DRG. 0-61-310-00902
DRAWING NO. 0-61-310-00934			REV. NO. OF SHEETS 16		

