



BHARAT HEAVY ELECTRICALS LIMITED
HEEP HARIDWAR INDIA-PIN 249403
FAX NO: 0091 1334 226462/223948
PHONE NO: 0091 1334 281478

Tender No.: F/T237/4/4145/H/1

Due Date: 02.03.2015

Sub: BHEL-HEEP/OPEN-TENDER (HIGH FIN (WRAPPED ON) TUBES)

Dear Sir,

The Heavy Electricals Equipment Plant (HEEP) located in Haridwar, India is one of the major manufacturing plants of Bharat Heavy Electricals Ltd. The core business of HEEP includes design and manufacture of large steam and gas turbines, turbo generators and so on. Government of India has a plan to add more than 1,20,000 MW in next five year plan (2012-2017).

Sealed tenders with the Tender No. and opening date clearly super scribed on the cover are invited from the manufacturers (registered as well as unregistered) for the supply of the following items:-

Tender No.	Item Description	Qty.
F/T237/4/4145/H/1	High Fin (Wrapped On) Tubes Spec: HE57065 Rev-01 Drawing no: 21660570032 Var-00 Rev-00	1960 Nos.
	High Fin (Wrapped On) Tubes Spec: HE57065 Rev-01 Drawing no: 21660170058 Var-00 Rev-01	2820 Nos.

The tender documents can be down loaded from our web site www.bhel.com or www.bhelhwr.co.in or www.tenders.gov.in or <http://eprocure.gov.in> submitted with requisite EMD and tender fee. **Only those vendors who fulfill the Minimum Qualifying Requirements (as per Annexure) will be considered for further technical evaluation.**

This notification shall be published in Indian as well as International News paper. **The last date for downloading tender documents shall be 01.03.2015 & opening of each tender shall be 02.03.2015.** Tenders will be received up to 01.45 P.M. on **02.03.2015** and opened on the same day at 2.00 P.M. in the Tender Room. **Please note that tender received after due date & time (01.45 PM on 02.03.2015) will not be REPEAT will not be opened.** BHEL will not be responsible for any type of postal / courier delay.

Intending vendors must remit the tender fee of Rs. 2,000/- (Rupees Two Thousand only) for indigenous vendors (or equivalent amount in foreign currency for foreign vendors) against each tender along with the requisite EMD Rs. 2,00,000/- (Rupees Two Lakhs only) in the form of bank draft while submitting the tender documents as detailed in "Instruction to Bidders", after down loading from this web site.

EMD may be waived in following cases-

- Central/ State – PSUs/ Government departments (Documentary proof required).
- Micro and Small Enterprises (Subject of submission of valid NSIC certificate)..

Tender fee of Rs. 2000/- may be exempted for Micro and Small Enterprises (Subject of submission of valid NSIC certificate).

Amendments / Corrigendum, if any, will be hosted on our web site only. Other terms and conditions will be as per tender documents.

The total quantity may undergo change at the time of ordering.

The details of each item with required delivery are given in **Annexure-IV (Details of Items)**

Please submit your Techno-Commercial offer only for the above requirement subject to our terms and conditions.

IN ADDITION TO VENDORS MENTIONED ABOVE, OFFERS SHALL ALSO BE OPENED OF ONLY THOSE VENDORS WHO WILL SUBMIT EMD AND TENDER FEE. [PLEASE SUB MIT SEPARATE DRAFTS FOR EMD AND TENDER FEE DRAWN IN FAVOUR OF BHEL, HARIDWAR IN ANOTHER ENVELOPE SUPERSCRIBED WITH BOLD LETTERS "EMD & TENDER FEE" at 2 PM on the due date in the presence of authorized representative of the bidders who may like to be present. The authorized representative should bring authority letter from their parent company (Manufacturer) for attending the bid opening.

KINDLY READ "INSTRUCTIONS TO BIDDERS." QUOTATION NOT IN ACCORDANCE WITH THE INSTRUCTIONS ARE LIABLE TO BE DISQUALIFIED AND IGNORED.

INSTRUCTIONS TO BIDDERS FOR OPEN TENDER

DEFINITION

Registered Vendors - Are those who are registered with BHEL, Haridwar for procurement of High Fin (Wrapped On) Tubes.

Un-registered Vendors - Are those who are not registered with BHEL, Haridwar for procurement of High Fin (Wrapped On) Tubes.

Un-registered vendors shall be considered, if and only if, they meet the minimum qualification requirement and quality requirements as given below.

MINIMUM QUALIFICATION REQUIREMENT

High Fin (Wrapped On) Tubes

Following is the mandatory requirement. Offer of Vendors not meeting these requirements will not be considered.

➤ **Technical Requirements-**

1. Vendor shall have minimum in-house manufacturing and testing facilities as below:
 - a. Online Root soldered Finning machine of high fin tube for finning of minimum 7m length.
 - b. Hydraulic testing facilities for testing of finned tubes at pressure 20Kg/sq.cm(a).
Vendor to furnish the supporting documents for above mentioned facilities.
2. Vendor shall have the following minimum experience:
Successfully manufactured and supplied minimum 5000 m total length of root soldered high fin tubes in last 3 years similar to drawing no. 2166070058 (Annexure-XII) for minimum 8 fins per inch and minimum 3m length of single tube. Vendor to furnish the purchase order and dispatch documents for the same.

OR

Successfully manufactured and supplied minimum 5000m total length of root soldered crimped fin tubes and minimum 5000m total length either of L/G/LL-fin with or without root soldered for minimum 3m length of single tube and minimum 8 fins per inch in last 5 years. Vendor to furnish the purchase order and dispatch documents for the same.

PQR documents as mentioned above are not required from registered vendors already supplied High Fin tubes to BHEL Haridwar.

➤ **Quality Requirements-**

1. All vendors to submit quality plan in the enclosed format (Annexure- VIII) for BHEL approval.
2. All vendors to confirm inspection by third party inspection agency (LRS/TUV/BV) in case of import and BHEL nominated agency 'TUV' in case of indigenous as per finally BHEL approved quality plan.
3. Scope of third party inspection/ BHEL nominated agency shall be :-
 - a. Witnessing of visual & dimensional check
 - i. Adhesion test & pitch measurement.
 - ii. Hydraulic test.
 - iii. Review of remaining TCs and all TCs of bare tube as per ordering drawing & specifications.
4. Bare tubes (Base Tubes) are to be procured from BHEL approved sources only.

Vendors must fill up Annexure – II in confirmation to above Minimum Qualifying Requirements and quality requirement.

ESSENTIAL INSTRUCTIONS

1. **Only those bids will be opened which have been submitted with requisite EMD & tender fee.**
2. **All un-registered vendors shall be approved by BHEL, if found suitable, on the basis of data furnished by them in Supplier Registration Form (SRF) Foreign Vendors or Indigenous Vendors. Vendor (s) shall not be considered for ordering if not approved by BHEL (Refer Annexure- VI & VII for SRF)**
3. **BHEL team may visit the vendor (s) works for verification of capability and capacity claimed in tender documents/offer (s).**
4. **The tender document must comprise of four envelopes:**
 - i) **Envelope I : Tender Fee & EMD or NSIC Certificate for exemption of tender fee & EMD.**
 - ii) **Envelope II : Pre- Qualifying Requirement & Supplier Registration Form.**
 - iii) **Envelope III : Techno -Commercial Bid.**
 - iv) **Envelope IV : Price Bid.**

It is essential that all the four envelopes comprising of the above information should be submitted on the due date otherwise the authenticity of tender date & time will be defeated. In view of the above, it is proposed that any offer should comprise of the above four envelopes at the time of tender opening.
5. The tenders shall be submitted in three parts
 - i. Part I - Techno -Commercial Bid,
 - ii. Part II - price Bid &
 - iii. Part III - Vendor Registration Form

as described below on or before the due date. Vendor Registration Form shall be submitted by unregistered vendors only.
6. **The Quotation should be from the Principal / Original Manufacturer, failing which the quotation is likely to be ignored. In Case the quotation is submitted through agent, the quotation must accompany original authorization letter.**
7. Any corrections / amendments shall be properly & fully authenticated with signature. No overwriting is acceptable.
8. In case of ordering, manufacturing plan should be submitted for BHEL approval.
9. Part-I containing techno-Commercial bid and part-III containing Vendor Registration Form will be opened on the date and time specified in the tender notice in the presence of those tenders who wish to attend.
10. Part-II (Price Bids) along with supplementary price bids, if necessary, will be opened at a later date of only those bidders whose techno-commercial bid has been found acceptable.
11. Suitability of delivery shall be the important criteria for evaluation of techno commercial bid and the bids falling within the delivery period and meeting the last delivery requirement. Any offers beyond this period shall be rejected.
12. Currency exchange rate will be applicable on the date of opening of Part-I (Techno-commercial Bid) for evaluation purpose.
13. **Depending upon the delivery suitability, BHEL reserves the right to split order on more than one vendor.**
14. **Evaluation of Bid: - The bid shall be evaluated**
 - a. **Cost to BHEL basis. (Basic Cost + Insurance + Transportation + Duty)**
 - b. **The loading, if any, on account of LD penalty, payment terms or any other cost determined at later stage, which shall be communicated to the vendor.**
15. Tenders when finalized shall be in the name of the bidder only and change of name during tender evaluation (without certificate from registrar of company) and after submission of the tender is liable to make the offer ineligible for participation.
16. All test certificates / Guarantee certificates to be submitted in TRIPLICATE along with dispatch documents.
17. BHEL reserves the right to open the price bid (part-II) along with the opening of techno-commercial offer at its option and in that case vendor will be informed accordingly.
18. **BHEL reserves the right to go for reverse auction. Vendors are requested to give their best price. In case of failure of reverse auction the paper bid shall be processed. Bidder should clearly indicate their acceptance for reverse auctioning in Annexure- I. The bids of those vendors who do not agree for reverse auction may not be considered. The Terms & Condition for Reverse Auctioning are given below.**
19. Total weight -- /Gross/ Net in Kg. & also package size essentially should be indicated if not exact then approximate.
20. BHEL will evaluate the technical bids against essential criteria/requirements. BHEL may seek clarifications, if required, from the qualified bidders only. These clarifications will be communicated to the eligible vendors. **The offers of those bidders, who are unable to respond in specified time frame, are likely to be ignored.**

21. MSE Suppliers can avail the intended benefits only if they submit along with the offer, attested copies of either EM II certificate having deemed validity (five years from the date of issue of acknowledgement in EM II) or valid NSIC certificate or EM II certificate along with attested copy of a CA certificate (Format enclosed at annexure-IX where deemed validity of EM II certificate of five years has expired) applicable for the relevant financial year (latest audited). Date to be reckoned for determining the deemed validity will be the date of bid opening (Part I in case of two part bid). Non submission of such documents will lead to consideration of their bid at par with other bidders.
- No benefit shall be applicable for this enquiry if any deficiency in the above required documents is found or the requisite documents are not submitted before price bid opening. If the tender is to be submitted through e-procurement portal, then the above required documents are to be uploaded on the portal. Documents should be notarized or attested by a Gazette officer.
22. Any new supplier will be eligible for registration with BHEL as MSE supplier provided at least any one of the following documents are submitted along with application for registration :- a. Valid NSIC Certificate or b. Entrepreneurs Memorandum part II (EM II) certificate (valid based on deemed validity of 5 years) or c. EM II certificate along with attested copy of CA Certificate (as per prescribed format at annexure IX) applicable for the relevant financial year (latest audited), where the deemed validity of EM II is over.
23. MSE vendors claiming SC/ST status will have to submit SC/ST certificate of the Proprietor from competent authority. Attested (notarized or attested by Gazetted officer) copy to be submitted along with the offer. In case techno-commercial accepted vendors include MSE source and their prices (based on landed cost to BHEL) are within the price band of 15% w.r.t. L-1 vendor, then BHEL can offer 20% of quantity of respective item (rounded off to nearest number) to MSE vendors at L-1 price and in case, more than one MSE vendor is in 15% band and the same is accepted by more than one MSE vendors then 20% quantities of respective items will be considered for ordering on proportionate basis amongst MSE vendors.
24. While distributing the 20% quantity amongst MSE vendors the decimal points in quantity shall be ignored for all the vendors except the L-1 amongst MSE vendors. Balance quantity after allocating the quantity to other MSE vendors ignoring the quantities in decimal, shall be given to L-1 (amongst MSE) vendor. However if there are more than one MSE vendor at the same price level than preference for additional quantities due to ignoring off the decimal (as mentioned above) shall be given to the vendor offering favourable terms to BHEL and if the conditions offered are also same then preference will be given to the vendor having high SPR rating.
25. In case there are more than one MSE vendors (with different landed cost to BHEL) within 15% price band of lowest bidder and quantity to be offered is 1 no. only, then preference shall be given to the MSE vendor with lowest landed cost.
26. In case there are more than one MSE vendors (with same landed cost to BHEL) within 15% price band of lowest bidder and quantity to be offered is 1 no. only, then preference shall be given first, based on the favorable terms in the bid and in case terms are also same, the vendor with high SPR rating shall be given preference. If L1 vendor is MSE vendor, entire quantity will be given to such MSE vendor only.
27. SETTLEMENT OF DISPUTES
- Indigenous Vendors: In all cases of dispute the matter shall be referred for arbitration to any arbitrator to be appointed by the Executive Director or any officer who is the administrative head of Bharat Heavy Electricals Ltd., at Haridwar. The venue of arbitration shall invariably be Ranipur Haridwar. The award of the arbitrator shall be final and binding on both the parties. The arbitrator shall have the power to extend, from time to time, the time for making his award with the consent of the parties.
 - Foreign Vendors: In the event of any dispute or difference arising between the parties to this contract regarding execution of same or their respective rights and liabilities there under, the same shall except as otherwise expressly provided therein, be referred to the arbitration of the two arbitrators, one to be appointed by each party; or in the case of the said arbitrators not agreeing then an umpire to be appointed by the two arbitrators in writing before entering on that reference and provisions of the Indian Arbitration Act, 1940 or any statutory notification, or re-enactment therefore and rules framed there under from time to time shall apply to such arbitration. If the two arbitrators do not agree on the appointment of umpire, the nomination of the umpire shall be done by the International Chamber of Commerce, Paris(France).The decision of arbitrators, or in case of their not agreeing, that of the said umpire shall be binding both on seller and purchaser. The venue of the arbitration invariably be New Delhi.
28. JURISDICTION
- All question, dispute or differences arising under, out of or in connection with the purchase order shall be subject to the exclusive jurisdiction of Haridwar courts.
29. OVER RIDING CLAUSE
- All stipulations made in any correspondence other than those exchanged in regards to “instruction” in our tender documents / enquiry for submission of your offer, if at all shall be void to the extent they are repugnant to the conditions contained herein above and in the purchase order.
30. FINALITY OF MANAGEMENT DECISION
- At all places in the preceding clauses BHEL Management’s decision shall be final.

IN CASE YOU ARE NOT MAKING AN OFFER AGAINST THIS ENQUIRY, THEN PLEASE ARRANGE TO SEND A LETTER OF REGRET IF YOU HAVE COLLECTED THE TENDER DOCUMENTS FROM BHEL.

DETAILS OF COMPOSITION OF PART-I (TECHNO-COMMERCIAL BID), PART-II (PRICE BID) & PART-III (VENDOR REGISTRATION FORM)

PART-I (TECHNO-COMMERCIAL BID) shall comprise of following documents:

- a. Confirmation to Minimum Qualification Requirement and Quality Requirement as per Annexure-II (For unregistered vendors only).
- b. Complete technical offer as per specification, drawings, technical requirement along with un-priced bid giving FOB rate.
- c. Delivery schedule.
- d. Inspection charges by LRS/TUV/BV separately for foreign vendors.
- e. Validity of offer to be indicated.
- f. **Annexure- I** - Compliance sheet for technical/commercial terms and conditions for two part tender.
- g. **Deviation with reference to specification/drawing, if any, should be clearly indicated on a separate sheet.**
- h. Details of activity outsourced.
- i. Copy of Quality Plan (Quality Plan placed at Annexure- VIII).
- j. Copy of Drawing- 21660570032 Var-00 Rev-00 and Drawing- 21660170058 Var-00 Rev-01 placed at Annexure- XII

PART –II (Price Bid)

- a. Price bid with prices to be submitted as part-II of the tender.
- b. Prices should remain firm till the execution of the order.
- c. **In case of foreign vendors, prices to be quoted on FOB basis only. In case of FOB, Loading port must be mentioned. In case of Indigenous vendor, prices may be quoted on FOR- Destination- Store-HEEP-BHEL basis.**
- d. Insurance – Marine in case of foreign vendor & inland in case of Indigenous vendor shall be taken care by BHEL.
- e. LRS/TUV/BV inspection charges to be quoted separately in case of foreign vendors.
- f. **Prices are to be written in both Figures & Words. In case of any difference between the two, the figure written in words shall be considered for evaluation. No over writing in this is acceptable.**
- g. LD Penalty shall be applicable at the rate of ½ % (half percent) per week or part thereof subject to a maximum of 10%. In case of any variation in LD penalty, your prices shall be loaded to the extent LD penalty not accepted by you.
 - Payment term shall be “100% payment against dispatch documents, through irrevocable LC or Cash against Documents (for foreign vendors) with bank charges as either side and after receipt and acceptance of material (for indigenous vendors)”. **BHEL as a rule do not agree to release advance payment.**
 - **Difference, if any, in cost in payment terms with respect to BHEL Payment terms (“100% payment against dispatch documents, through irrevocable LC (for foreign vendors) and after receipt and acceptance (for indigenous vendors)” shall be loaded in prices of vendor.**
- h. Irrevocable LC is opened for one quarter (3 months) & is established 45 days prior to delivery schedule. The charges of establishing the LC are on either side i.e. charges in India to be borne by BHEL and charges outside of India to be borne by vendor. If any vendor insists for LC for more than one quarter, vendor has to essentially bear all charges (Within & outside India) for the period exceeding one quarter.
- i. **BHEL does not open confirmed LC even if vendor agrees to bear the confirmation charges.**

**Part-III - Vendor Registration Form (SRF)
(SRF-Foreign Suppliers or SRF-Indian Suppliers)**

- a. The SRF (as applicable) duly filled up will be assessed for manufacturing capability quality systems being followed, organizational soundness and financial worthiness. The same shall be submitted with Part-I (Techno-Commercial Bid) by un-registered vendor only with BHEL, HEEP, Haridwar.

MARKING OF ENVELOPE:

- Each envelop is to be super scribed as “TEN DER FOR (ITEM NAME) AGAINST TENDER NO.----- DUE ON -----
- Drafts for Tender Fee & EMD to be kept in one envelop – Envelop –A. On the Top of the envelope, please write Draft No., Issuing Bank Details & Amount. Those vendors who are quoting for more than one tender must submit a statement in the envelopes of all those tenders giving details of all the tenders being quoted. However, the draft of each tender should be kept in individual tender envelop.
- Techno-Commercial - Part-I to be kept in another envelop – Envelop-B & to be marked as Techno-Commercial Offer.
- Vendor Registration Form - Part –III to be kept in another envelop – Envelop – C & to be marked as Vendor Registration Form.
- Price Bid – Part-II to be kept in another envelop – Envelop-D & to be marked as Price Bid.
- Envelop-A, Envelop-B, Envelop-C & Envelop-D are to be kept in one envelop super scribed as above

Envelopes not marked as above are liable to be ignored and will not be opened.

ANNEXURE-I

COMPLIANCE SHEET FOR TECHNICAL/COMMERCIAL TERMS AND CONDITIONS FOR TWO PART TENDER

PLEASE FILL THIS ANNEXURE & ATTACH WITH YOUR TECHNO-COMMERCIAL BID.

Offer must be sent in two separate sealed envelopes containing techno-commercial offer in one envelope marked "TECHNO-COMMERCIAL BID" and prices in second envelope marked "PRICE-BID". Both the envelopes must be contained in the main envelope. Tender name and due date to be marked on all the envelopes.

You are requested to kindly confirm /clarify the following:-

S. No.	Description	Vendor's Confirmation
1	Vendor to confirm that they meet each & every clause of our specifications/Drawings.	YES / NO
2	If "No" to serial number 1, vendor to specify each deviated clause & submit in a separate sheet.	
3	Vendor to list out on a separate sheet any activity which is outsourced. Please furnish details of out sourced vendor.	
4	Validity: confirm that validity of the offer shall be 90 days from the date of tender opening	YES / NO
5	Confirm that un-priced part of price bid is enclosed with technical commercial offer	YES / NO
6	Confirm delivery quoted as per enquiry	YES / NO
7	Confirm that prices are quoted inclusive of third party inspection charges on FOB basis.	YES / NO
8	Confirm that Loading Port has been mentioned.	YES / NO
9	Confirm that prices shall be firm and fixed throughout delivery period and No PVC clause is applicable or acceptable.	YES / NO
10	Confirm that payment term shall be "On collection basis through SBI/PNB Ranipur, Hardwar" (CAD)	YES / NO
11	LD Penalty shall be applicable at the rate of ½ % (half percent) per week or part thereof subject to a maximum of 10%.	YES / NO
12	Confirm that all test certificates & guarantee certificate are to be submitted along with the supply as per BHEL specification in TRIPLICATE along with despatch documents	YES / NO
14	Right of acceptance – BHEL reserves the right to reject any or all quotations without assigning any reasons thereof. BHEL also reserves the right to increase or decrease the tendered quantities. Vendors should be prepared to accept order for reduced quantities without any extra charges. Vendor should also be prepared for giving discount in case of increase in quantity.	YES / NO
15	Confirm specifically that material shall be supplied as per tender documents.	YES / NO
16	Ink signed order acceptance shall be furnished within 15 days of order placement.	YES / NO
17	Confirm if there is Indian agency commission.	YES / NO
18	Please confirm to participate in Reverse Auction on FOB basis inclusive third party inspection charges for foreign suppliers. For Indian suppliers, please quote your rates without inspection charges on FOR Destination basis, your rates will be loaded accordingly for inspection charges as Inspection will be arranged by BHEL.	YES / NO
19	Confirm acceptance of Risk Purchase clause.	YES / NO
20	Confirm to send original ink signed copy of offer, if offer has been sent through email or FAX or photocopy has been submitted.	YES / NO

ANNEXURE-II

MINIMUM QUALIFICATION REQUIREMENT FOR HIGH FIN TUBES

Following is the mandatory requirement. Offer of Vendors not meeting these requirements will not be considered.

➤ **Technical Requirements-**

Sl. No.	Technical Requirement	Vendor's confirmation (Y/N)
01	<p>Vendor shall have minimum in-house manufacturing and testing facilities as below:</p> <ol style="list-style-type: none"> a. Online Root soldered Finning machine of high fin tube for finning of minimum 7m length. b. Hydraulic testing facilities for testing of finned tubes at pressure 20Kg/sq.cm(a). <p>Vendor to furnish the supporting documents for above mentioned facilities.</p>	
02	<p>Vendor shall have the following minimum experience:</p> <p>Successfully manufactured and supplied minimum 5000 m total length of root soldered high fin tubes in last 3 years similar to drawing no. 2166070058 (enclosed) for minimum 8 fins per inch and minimum 3m length of single tube. Vendor to furnish the purchase order and dispatch documents for the same.</p> <p style="text-align: center;">OR</p> <p>Successfully manufactured and supplied minimum 5000m total length of root soldered crimped fin tubes and minimum 5000m total length either of L/G/LL-fin with or without root soldered for minimum 3m length of single tube and minimum 8 fins per inch in last 5 years. Vendor to furnish the purchase order and dispatch documents for the same.</p>	

Note:- PQR documents as mentioned above in clause no-1 & 2 are not required from registered vendors already supplied High Fin tubes to BHEL Haridwar.

➤ **Quality Requirements-**

Sl. No.	Quality Requirement	Vendor's confirmation (Y/N)
01	<ol style="list-style-type: none"> 1. All vendors to submit quality plan in the enclosed format (Annexure- VIII) for BHEL approval. 2. All vendors to confirm inspection by third party inspection agency (LRS/TUV/BV) in case of import and BHEL nominated agency 'TUV' in case of indigenous as per finally BHEL approved quality plan. 3. Scope of third party inspection/ BHEL nominated agency shall be :- <ol style="list-style-type: none"> a. Witnessing of visual & dimensional check <ol style="list-style-type: none"> 1. Adhesion test & pitch measurement. 2. Hydraulic test. 3. Review of remaining TCs and all TCs of bare tube as per ordering drawing & specifications. 4. Bare tubes (Base Tubes) are to be procured from BHEL approved sources only. 	

Signature with stamp

Name:

Name of Firm:

Designation:

Date:

ANNEXURE-III

TERMS AND CONDITIONS OF REVERSE AUCTIONING

Against this enquiry for the subject item/ system with detailed scope of supply as per enquiry specifications, BHEL may resort to "REVERSE AUCTION PROCEDURE" i.e., **ON LINE BIDDING (THROUGH A SERVICE PROVIDER)**. The philosophy followed for reverse auction shall be English Reverse (No ties).

1. For the proposed reverse auction, technically and commercially acceptable bidders only shall be eligible to participate.
2. Those bidders who have given their acceptance for Reverse Auction (quoted against this tender enquiry) will have to necessarily submit „online sealed bid“ in the Reverse Auction. Non-submission of „online sealed bid“ by the bidder for any of the eligible items for which techno-commercially qualified, will be considered as tampering of the tender process and will invite action by BHEL as per extant guidelines in vogue.
3. BHEL will engage the services of a service provider who will provide all necessary training and assistance before commencement of on line bidding on internet.
4. In case of reverse auction, BHEL will inform the bidders the details of Service Provider to enable them to contact & get trained.
5. Business rules like event date, time, bid decrement, extension etc. also will be communicated through service provider for compliance.
6. Bidders have to fax the Compliance form (annexure X) before start of Reverse auction. Without this, the bidder will not be eligible to participate in the event.
7. In line with the NIT terms, BHEL will provide the calculation sheet (e.g., EXCEL sheet) which will help to arrive at "Total Cost to BHEL" like Packing & forwarding charges, Taxes and Duties, Freight charges, Insurance, Service Tax for Services and loading factors (for non-compliance to BHEL standard Commercial terms & conditions) for each of the bidder to enable them to fill-in the price and keep it ready for keying in during the Auction.
8. Reverse auction will be conducted on scheduled date & time.
9. At the end of Reverse Auction event, the lowest bidder value will be known on auction portal.
10. The lowest bidder has to fax/e-mail the duly signed and filled-in prescribed format for price breakup including that of line items, if required, (**Annexure XI**) as provided on case-to-case basis to Service provider within two working days of Auction without fail.
11. In case BHEL decides not to go for Reverse Auction procedure for this tender enquiry, the Price bids and price impacts, if any, already submitted and available with BHEL shall be opened as per BHEL"s standard practice.
12. Bidders shall be required to read the "Terms and Conditions" section of the auctions site of Service provider, using the Login IDs and passwords given to them by the service provider before reverse auction event. Bidders should acquaint themselves of the „Business Rules of Reverse Auction“, which will be communicated before the Reverse Auction.
13. If the Bidder or any of his representatives are found to be involved in Price manipulation/ cartel formation of any kind, directly or indirectly by communicating with other bidders,

action *as per extant BHEL guidelines*, shall be initiated by BHEL and the results of the RA scrapped/ aborted.

14. The Bidder shall not divulge either his Bids or any other exclusive details of BHEL to any other party.
- 15. In case BHEL decides to go for reverse auction, the H1 bidder (whose quote is highest in online sealed bid) may not be allowed to participate in further RA process.**

ANNEXURE-IV

(Item Details and Delivery Schedule)

Tender No.	Material Code	Description	Specification	Qty. (Nos.)	Delivery
F/T237/4/4145/H/1	W96716601570	High Fin (Wrapped On) Tubes	Spec: HE57065 Rev-01 Drg no: 21660570032 Var-00 Rev-00	1960	1 st Lot (980 Nos) - 30.06.2015 2 nd Lot (980 Nos)- 30.07.2015
	W96716601490		Spec: HE57065 Rev-01 Drg no: 21660170058 Var-00 Rev-01	2820	1 st Lot (1128 Nos)- 30.06.2015 2 nd Lot (1692 Nos)- 30.07.2015

ANNEXURE-V

(Specification- HE57065 Rev-01)



उत्पाद मानक

HE57065

PRODUCT STANDARD

पृष्ठ का Page 1 of 3

HIGH FIN (WRAPPED ON FIN) TUBE

1.0 Scope :

This standard covers the requirement of High Fin (Wrapped On Fin) Tube, wrapped externally over the tubes with root soldered.

2.0 Application :

These tubes are mainly used in Gas/ Air Coolers.

3.0 Compliance to Standards: The standard is based on BHEL own experience.

4.0 Technical Requirement :

4.1 Condition of delivery :

High Fin (Wrapped on Fin) Tube shall be supplied with the required configuration of high fin fully soldered over the base tube as per drawing. Each tube shall be hydraulically tested. Tube ends shall be square cut and free from solder material/ chemicals etc. so that the ends must be suitable for roller expansion joints. The Finned Tubes shall be packed suitably as per BHEL's approved Packing procedure.

4.2 Manufacturing Process :

High Fin (Wrapped on Fin) Tube shall be manufactured exactly as per geometrical details (number of turns, pitch, fin height, fin size etc) as specified in the drawing supplied. Root of the fin to be soldered with base tube. The bonding of fins to the base tube should be perfect without any air gap for effective heat transfer. The bonding shall also be mechanically strong and robust to make the tube suitable for their use in gas/air coolers of TG sets. If necessary, the base tube can be tinned for proper bonding/ soldering.

4.3 Material :

- 1. Tube :- 90:10 Cu Ni as per ASTM B111 C70600 from BHEL approved vendors.
2. Fin :- 99.9% Cu as per ASTM C11000
3. Solder Wire :- 1S:1921 Gr 35 or Equivalent

5.0 Dimensions & Tolerances:

Refer drawing.

6.0 Documents to be Submitted :

Following documents shall be submitted along with the offer for BHEL approval.

- 1. Quality plan.

Form containing approval signatures and dates for TSX, B. CHAUDHARY, DEEPAK KUMAR, SUGANDH, ASHISH GUPTA, SHASHI KANT, and M. K. LAHOTI, AGM (HXE) with dates ranging from 21/06/13 to 22-05-2014.

COPYRIGHT AND CONFIDENTIAL The information on this document is the property of Bharat Heavy Electrical Limited. It must not be used directly or indirectly in any way detrimental to the interest of the company.

स्वत्वाधिकार एवं गोपनीय इस प्रलेख में दी गई सूचना भारत भारती इलेक्ट्रिकल्स की सम्पत्ति है इसका प्रलेख एवं अप्रलेख रूप से किसी भी तरह प्रयोग, जो कि कंपनी के हित में हानिकारक हो न किया जाए।

दिनांक एवं हस्ताक्षर SIGN & DATE		उत्पाद मानक (हीप - हरिद्वार) PRODUCT STANDARD (HEEP - HARDWAR)	HE57065 पृष्ठ का Page 2 of 3			
सामग्री सूची संख्या को SUPERSEDES INVENTORY	2. Process chart clearly indicating the process & sequence of manufacturing. 3. Detailed packing procedure.					
COPYRIGHT AND CONFIDENTIAL The information on this documents is the property of Bharat Heavy Electrical Limited. It must not be used directly or indirectly in any way detrimental to the interest of the company.	7.0 Inspection & Testing : i) BHEL's representative shall have a free access at all times to all parts of manufacturer's works, until work on contract of BHEL is being performed. The supplier shall offer to BHEL's representative, all reasonable facilities without charge to satisfy the later that the material is being produced in accordance with this specification. ii) If specified in the purchase order, the test certificate shall be approved by BHEL's representative/ BHEL approved third party inspection agency. iii) Vendor shall advise purchaser at least 4 weeks in advance when items are ready for inspection. iv) A type test for testing the bonding strength, between fins and tube, shall be done by the vendor in presence of BHEL representative as per Annexure-I. No breakage of joint/elongation/gap is acceptable. Type test report is valid for a period of one year incase process parameter (machine number, speed, feed temperature etc), material and dimensions are not changed. v) 100% tubes shall be subjected to hydraulic test at 20 kg/cm ² for 10 seconds after finning as per ASME, Sec VIII, Div1, UG-99. No leakage is acceptable.					
स्वत्वाधिकार एवं गोपनीय इस प्रलेख में दी गई सूचना भारत हेतु इलेक्ट्रिकल्स की सम्पत्ति है इसका प्रलेख एवं अप्रलेख रूप से किसी भी तरह प्रयोग, जो कि कंपनी के हित में हानिकारक हो न किया जाए।	8.0 Test Certificate : Following documents test certificate shall be furnished by the supplier along with supply. i) All test certificates (Chemical, Mechanical, Hydraulic, Eddy current test etc.), for bare tube as specified in drawing and specification. ii) Test certificate of fin material. iii) Test certificate for fin to tube bonding strength. iv) Test report of Hydraulic test after finning. v) Inspection Report of finished finned tube. The test certificates shall bear the following information- 1. BHEL References : BHEL Order No. 2. Supplier's References : As per base standard referred on the drawing.					
दिनांक एवं हस्ताक्षर SIGN & DATE 11/16/13	9.0 Packing and Marking : Tubes shall be packed suitably to avoid any damage of tubes during handling, transportation and storage. Suitable supports for tubes may be provided in packing box to avoid the damage on fins.					
सामग्री सूची संख्या INVENTORY NO. P-6438	REV.NO. 01	10.0 Referred Standards : 1. ASTM B111 C70600 2. ASTM C11000 3. IS:1921 Gr 35 4. ASME, Sec VIII, Div1		निर्माणकर्ता WORKED BY ASHISH GUPTA	जांचकर्ता CHECKED BY SHASHI KANT	Ashish 29/5/13 Shashi 01/06 2013

सामग्री सूची संख्या को
 SUPERSEDES INVENTORY

ANNEXURE-I

TESTING PROCEDURE FOR BONDING STRENGTH BETWEEN FINS AND TUBE

Type test for testing the mechanical bonding strength between Fins and Tube shall be done by vendor in presence of BHEL representative.

Sample Size:

1. One number (randomly selected) cut finned tube of 150 mm length.
2. Obtain a sector chord of 12 mm at the root of the fin.

Procedure:

1. Make a suitable arrangement to tag or make hook so that 5Kg load may be suspended on fin(as shown in fig-1).
2. Force of 5Kg to be suspended on fin of sample for 10 minutes.

Acceptance:

1. There should not be any crack or gap at root of fin (joint of fin and tube).
2. Type test report is valid for a period of one year incase process parameter (machine number, speed, feed temperature etc), material and dimensions are not changed.

COPYRIGHT AND CONFIDENTIAL
 The information on this documents is the property of Bharat Heavy Electrical Limited. It must not be used directly or indirectly in any way detrimental to the interest of the company

स्वत्वाधिकार एवं गोपनीय
 इस प्रलेख में दी गई सूचना भारत हेवी इलेक्ट्रिकल्स की सम्पत्ति है इसका प्रत्यक्ष एवं अप्रत्यक्ष रूप से किसी भी तरह प्रयोग, जो कि कंपनी के हित में हानिकारक हो न किया जाए ।

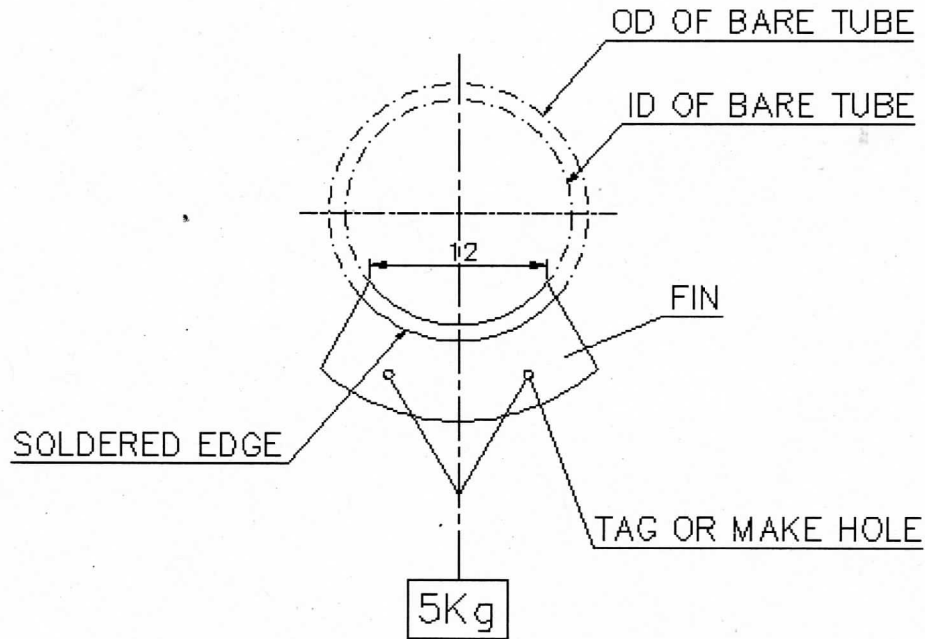

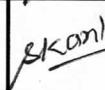

Fig-1

हस्ताक्षर एवं दिनांक
SIGN & DATE
 17/6/13

सामग्री सूची संख्या
INVENTORY NO.
 P-6438

REV.NO.	01				
---------	----	--	--	--	--

निर्माणकर्ता WORKED BY	ASHISH GUPTA	 29/5/13	
जांचकर्ता CHECKED BY	SHASHI KANT	 01/06 2013	

ANNEXURE-VI

(Supplier Registration Form Indigenous Vendor)

	Annexure-VI GUIDELINES TO INDIAN SUPPLIERS FOR FILLING-UP SUPPLIER REGISTRATION FORM	Document No.	AA:MM:SR:01
		Revision No.	01
		Page No.	I of II

- Prospective Suppliers may also visit our web site www.bhel.com (link Supplier Registration -> New Supplier Required) to know more about the requirement of new suppliers for various items in our units.
- Registration Form may be obtained from BHEL website www.bhel.com.
- Application for registration, with a covering letter detailing where your products can find application (if possible) in BHEL unit(s), should be sent to:

Supplier Development Cell
Unit Name:
Bharat Heavy Electricals Ltd.
City:
India

- In case registration is being sought in multiple units of BHEL, please send the separate application to each unit.
- Any clarification with respect to procedure for registration may be obtained from the Supplier Development Cell of respective BHEL unit.
- The Supplier Registration Form has four parts:

Part A	Organisational Information	Form no. SRF(I)01 – page 1 to 10
Part B	Quality System	Form no. SRF(I)01 - page 11 to 12
Part C	Technical Competence	Form no. SRF(I)01 page 13 (if sent by BHEL)
Part D	Score Sheet (to be filled by BHEL)	Form no. SRF(I)01 page 14 to 17

The set of formats to be filled by different category of suppliers is as follows:

Sl.No	Supplier Category	Formats
1.	Indian Suppliers (manufacturers)	- Organisational Information - Quality System - Technical Competence
2.	Indian Stockist/ Trader/ Distributor/ Dealer/ Authorised Agent/ Channel partner/ Indian Sales office or Subsidiary of registered foreign principal	- Organisational Information SRF(I)01- Part A (page 1 to 10 except Sl. No. 5.1, 5.2, 6.6, 6.7, 7 & 8)

- All columns are to be filled up properly in the space provided for. Wherever it is not applicable, please mention “Not Applicable”. The form is to be signed by the authorised signatory.
- A separate sheet may be attached if the space provided is insufficient or additional information is to be given. Please put proper identification tag on the separately attached sheet.
- Please ensure that all required enclosures are attached with the filled up Supplier Registration Form and all enclosures are numbered & list of enclosures is given as required.
- As multiple copies of the application forms are required for processing at our end, please do not spiral bound the application forms or its enclosures and instead send them in two hole clip flat file.
- Incomplete forms will be rejected.
- Any information / clarification required by BHEL during evaluation must be given expeditiously.
- Please note that if you are registered and participate in Tender process and qualify to get order from BHEL, your performance based on Quality of your product, delivery performance and service rendered will be evaluated inline with Chapter VI.
- Please fill up the check- list given on next page and send along with the Supplier Registration Forms to BHEL.
- If you are attaching a document in a language other than Hindi/ English, a self attested Hindi/ English translated document may please be also attached.

	Annexure-VI Check List for Indian Supplier Registration Form	Document No.	AA:MM:SR:01
		Revision No.	01
		Page No.	II of II

Sl.No.	Check-Point	Yes/No
1.	Information against all points under “Organizational Information” (Part-A) has been given.	
2.	All enclosures and supporting documents have been enclosed.	
3.	Summary list of enclosures has been furnished as per S.N.10 of Organisational Information form no. SRF (I) 01 & S.N 12 of Quality system form no. SRF (I) 01.	
4.	Are you an ISO 9001 accredited supplier?	
5.	If yes, have you enclosed "Table of Contents" of your Quality Manual and copy of ISO 9001 accreditation certificate?	
6.	Have you filled up Quality System format given in Part B?	
7.	Technical requirements, specifications, drawings, standards have been received from BHEL before filling up Technical Competence, Part C.	
8.	All the parts of the form & enclosures have been signed by Authorised Signatory.	
9.	Have you attached EFT details? (In original, Certified by the bank)	
10.	If you are seeking registration for a MSME company (as per MSME Act of Government of India), have you attached requisite certificate as per Act?	

Date :

Signature & seal

(Authorised Signatory)

Note: This check list is to be attached with the filled up Supplier Registration Form.

**BHARAT HEAVY ELECTRICALS LIMITED
SUPPLIER REGISTRATION FORM**

FORM NO. SRF(I) 01 (INDIAN SUPPLIER)

ANNEXURE-VI

Page 1 of 17

INFORMATION WITH * MARKS IS SCOREABLE.

PART- A : ORGANISATIONAL SOUNDNESS

ALL COLUMNS SHOULD BE PROPERLY FILLED IN THE SPACE PROVIDED FOR, WHEREVER IT IS NOT APPLICABLE, PLEASE WRITE "NOT APPLICABLE". INCOMPLETE OR INCORRECT FORMS MAY NOT BE CONSIDERED. **PLEASE ATTACH SEPARATE SHEET, IF SPACE AVAILABLE IS INADEQUATE.**

ALL THE PAGES OF THE FORM ARE TO BE SIGNED ALONGWITH SEAL BY THE AUTHORISED SIGNATORY

ORGANISATIONAL INFORMATION			
NAME AND CORRESPONDENCE ADDRESS OF THE SUPPLIER SEEKING REGISTRATION :-			
1.0 PRODUCTS / SYSTEMS / SERVICES FOR WHICH REGISTRATION IS APPLIED FOR :			
SL. NO.	DESCRIPTION	SIZE & RANGE	MFG. STD/ IS / DIN /BS ETC.
SUPPLIER'S AUTHORISED SIGNATORY		BHEL CERTIFIED ASSESSOR	

**BHARAT HEAVY ELECTRICALS LIMITED
SUPPLIER REGISTRATION FORM**

FORM NO. SRF(I) 01 (INDIAN SUPPLIER)

ANNEXURE-VI

Page 2 of 17

ORGANISATIONAL INFORMATION

2.0 GENERAL INFORMATION :

2.1 NAMES OF THE WORKS/DIVISION (Products manufactured at each works to be mentioned :

ADDRESS :

E - Mail :

TELEPHONE : Landline

Mobile

FAX :

2.2 NAME OF CHIEF EXECUTIVE /
PROPRIETOR / PARTNER & ADDRESS :

2.3 DETAILS OF AUTHORISED SIGNATORY FOR SEEKING CLARIFICATION :

NAME :

DESIGNATION :

E - Mail :

TELEPHONE : Landline

Mobile

FAX :

SUPPLIER'S AUTHORISED SIGNATORY

BHEL CERTIFIED ASSESSOR

**BHARAT HEAVY ELECTRICALS LIMITED
SUPPLIER REGISTRATION FORM**

FORM NO. SRF(I) 01 (INDIAN SUPPLIER)

ANNEXURE-VI

Page 3 of 17

ORGANISATIONAL INFORMATION

3.0 OWNERSHIP INFORMATION : DOCUMENTS TO BE FURNISHED

3.1 GOVT. OF INDIA UNDERTAKING:

OR

STATE GOVT. UNDERTAKING :

OR

LIMITED COMPANY, :

MEMORANDUM AND
ARTICLES OF ASSOCIATION

OR

PRIVATE COMPANY :

MEMORANDUM AND
ARTICLES OF ASSOCIATION

OR

CO-OPERATIVE SOCIETY, :

SOCIETY RULES AND
BYE LAWS

OR

PARTNERSHIP FIRM, :

PARTNERSHIP DEED

OR

PROPRIETORSHIP, :

PROFESSION TAX REGN.
AND MUNICIPAL REGN.

ANY OTHER (SPECIFY) :

3.2 NATURE OF BUSINESS :
(MANUFACTURING UNIT/
ENGG CONSULTANT/ EPC CONTRACTOR)

(AGENTS/ DISTRIBUTORS/STOCKISTS/DEALERS/
TRADERS/ INDIAN SUBSIDIARY/ CHANNEL PARTNER – attach authorization
certificate of principal)

3.3 YEAR OF ESTABLISHMENT :

* 3.4 YEAR OF COMMENCEMENT OF BUSINESS :

SUPPLIER'S AUTHORISED SIGNATORY

BHEL CERTIFIED ASSESSOR

**BHARAT HEAVY ELECTRICALS LIMITED
SUPPLIER REGISTRATION FORM**

FORM NO. SRF(I) 01 (INDIAN SUPPLIER)

ANNEXURE-VI

Page 4 of 17

ORGANISATIONAL INFORMATION

4.0 REGISTRATION PARTICULARS

(FURNISH DETAILS AND ENCLOSE COPY OF CERTIFICATE FOR THE FOLLOWING)

- 4.1 PERMANENT ACCOUNT NO :
4.2 CENTRAL SALES TAX REGN NUMBER :
4.3 STATE SALES TAX / TIN NUMBER :
4.4 EXCISE DUTY REGN NUMBER :
4.5 EXCISE CONTROL CODE NUMBER :
4.6 SERVICE TAX REGN NUMBER :
4.7 CATEGORY AS PER MSMED ACT : MICRO/ SMALL/ MEDIUM
REGN NO. :
VALID UPTO :
(Attach Certificate)

5.0 TOTAL ORGANISATIONAL STRENGTH : (ATTACH ORGANISATION CHART)

- | | GRADUATE | DIPLOMA | SKILLED | NON-SKILLED |
|--|----------|---------|---------|-------------|
| ENGINEERING : | | | | |
| MANUFACTURING : | | | | |
| QUALITY : | | | | |
| COMMERCIAL /
SERVICE AFTER SALES : | | | | |
| OTHERS : | | | | |
| TOTAL : | | | | |
| * 5.1 POWER BACKUP :
(GIVE DETAILS) | YES/ NO | | | |
| * 5.2 DOES THE COMPANY SELL ITS PRODUCT DIRECTLY : | YES/ NO | | | |

SUPPLIER'S AUTHORISED SIGNATORY

BHEL CERTIFIED ASSESSOR

**BHARAT HEAVY ELECTRICALS LIMITED
SUPPLIER REGISTRATION FORM**

FORM NO. SRF(I) 01 (INDIAN SUPPLIER)

ANNEXURE-VI

Page 5 of 17

ORGANISATIONAL INFORMATION

6.0 OTHER PARTICULARS :

(FURNISH DETAILS AND ENCLOSE DOCUMENTARY EVIDENCE/ COPY OF CERTIFICATE FOR THE FOLLOWING)

* 6.1 IF THE COMPANY IS ALREADY REGISTERED WITH ANY OF BHEL UNITS, GIVE :

6.1.1. BHEL UNIT'S NAME :

6.1.2. SUPPLIER REGN. CODE NO. :

6.1.3. ITEMS FOR WHICH REGISTERED & THEIR SPECIFICATION
(ENCLOSE PROOF OF SUCCESSFUL EXECUTION OF
ONE OR MORE PURCHASE ORDERS) :

* 6.2 IS THE COMPANY APPROVED BY
ASME / NTPC / NPC / EIL / DGS&D / RAILWAYS /
IBR / LLOYDS ETC FOR INTENDED
MATERIAL CATEGORY? : YES / NO
(ENCLOSE DOCUMENTARY EVIDENCE)

* 6.3 IS THE COMPANY ISO 9001 APPROVED? : YES / NO
(ENCLOSE CERTIFICATE & TOC OF QUALITY SYSTEM) :

* 6.4 IS THE COMPANY AN ISO 14000 APPROVED? : YES / NO
(ENCLOSE CERTIFICATE) :

* 6.5 IS THE COMPANY OHSAS - 18000 APPROVED?: YES / NO
(ENCLOSE CERTIFICATE)

* 6.6 TECHNICAL COLLABORATOR :
(FOREIGN OR INDIGENOUS)
(ENCLOSE DOCUMENTARY EVIDENCE)

* 6.7 R&D SET UP

6.8 DIRECTORS / PARTNERS, IF RELATED TO ANY
BHEL EMPLOYEE.
NAME :
STAFE NO. :
DESIGNATION :
Unit & DEPARTMENT :
RELATIONSHIP :

SUPPLIER'S AUTHORISED SIGNATORY

BHEL CERTIFIED ASSESSOR

**BHARAT HEAVY ELECTRICALS LIMITED
SUPPLIER REGISTRATION FORM**

FORM NO. SRF(I) 01 (INDIAN SUPPLIER)

ANNEXURE-VI

Page 6 of 17

ORGANISATIONAL INFORMATION

6.9 IF ANY EX-BHEL PERSONNEL IS EMPLOYED BY THE COMPANY, MENTION HIS / HER DETAILS OF LAST POSTING.

NAME :
STAFF NO. :
DESIGNATION :
UNIT & DEPARTMENT :
DATE OF LEAVING SERVICE :

6.10 COMPANY'S WEEKLY HOLIDAYS :

WORKS OFFICE

6.11 EXPERIENCE LIST:

(ATTACH LIST OF PRESENT CUSTOMERS WITH NAME & ADDRESS FOR OFFERED / SIMILAR TYPE & SIZE OF ITEM / EQUIPMENT FOR WHICH REGISTRATION HAS BEEN SOUGHT AND WITH WHOM YOU HAVE CONTINUOUS BUSINESS SINCE LAST THREE YEARS . ALSO ATTACH PERFORMANCE CERTIFICATES ISSUED BY ANY TWO CLIENTS FOR SUCCESSFUL EXECUTION OF THE CONTRACTS FOR LAST TWO YEARS- FOR PEM)

*6.12 DETAILS OF PENDING LEGAL ISSUES ON CONTRACTUAL ASPECTS WITH CUSTOMER , IF ANY

6.13 The following information of Bank Account of the Company, duly endorsed by the Bank (required for Electronic Fund Transfer –EFT/RTGS) is to be submitted

1. Name of the Company
2. Name of Bank
3. Name of Bank Branch
4. City/Place
5. Account Number
6. Account type
7. IFSC code of the Bank Branch
8. MICR Code of the Bank Branch
9. Details of other Bankers (for reference purpose only)

NOTE :

Suppliers who have already submitted the above information are requested to submit a copy of the same.

SUPPLIER'S AUTHORISED SIGNATORY

BHEL CERTIFIED ASSESSOR

**BHARAT HEAVY ELECTRICALS LIMITED
SUPPLIER REGISTRATION FORM**

FORM NO. SRF(I) 01 (INDIAN SUPPLIER)

ANNEXURE-VI

Page 7 of 17

ORGANISATIONAL INFORMATION

7.0 MANUFACTURING FACILITIES:

***7.1 LIST OF MANUFACTURING FACILITIES/EQUIPMENTS (INCLUDING MATERIAL HANDLING FACILITY)**

SL. NO	DESCRIPTION OF MACHINE/EQUIPMENT	QUANTITY	MAKE & YEAR OF INSTALLATION	REMARKS

IN CASE OF SPACE LIMITATION, PLEASE ENCLOSE ANNEXURE / CATALOGUE WITH TAG

*** 7.2 IF IN-HOUSE MFG FACILITIES NOT AVAILABLE, INFORM SOURCE OF MFG. DETAILS ALONGWITH THEIR FACILITIES & EXPERIENCE**

SL. NO	PROCESS OUTSOURCED	NAME OF THE COMPANY	DESCRIPTION OF MACHINE / EQUIPMENT	REMARKS

IN CASE OF SPACE LIMITATION ENCLOSE ANNEXURE / CATALOGUE WITH TAG

*** 7.3 RATIO OF OUTSOURCED COST TO TOTAL PRODUCTION VALUE:**

SUPPLIER'S AUTHORISED SIGNATORY

BHEL CERTIFIED ASSESSOR

**BHARAT HEAVY ELECTRICALS LIMITED
SUPPLIER REGISTRATION FORM**

FORM NO. SRF(I) 01 (INDIAN SUPPLIER)

ANNEXURE-VI

Page 8 of 17

ORGANISATIONAL INFORMATION

8.0 INSPECTION & TESTING FACILITIES:

*** 8.1 LIST OF INSPECTION & TESTING FACILITIES / EQUIPMENT**

SL. NO	DESCRIPTION OF FACILITY/ EQUIPMENT & CAPACITY	NOS.	MAKE & YEAR OF MANUFACTURING	LAST DATE OF CALIBERATION

IN CASE OF SPACE LIMITATION ENCLOSE ANNEXURE / CATALOGUE WITH TAG

*** 8.2 IF IN-HOUSE TESTING FACILITIES NOT AVAILABLE, INDICATE SOURCE OF TESTING ALONGWITH THEIR FACILITIES & EXPERIENCE**

SL. NO	TEST	SOURCE OF TESTING	DESCRIPTION OF FACILITY/ EQUIPMENT & CAPACITY	APPROVAL OF EQUIPMENT/ PROCESS/PERSONNEL QUALIFICATION

IN CASE OF SPACE LIMITATION ENCLOSE ANNEXURE / CATALOGUE WITH TAG

Note:

In case of outsourcing of major testing such as NDT, Electrical & Mechanical Testing, no marks will be awarded. However, material composition testing by chemical method from recognized laboratory shall not attract negative marking

SUPPLIER'S AUTHORISED SIGNATORY

BHEL CERTIFIED ASSESSOR

BHARAT HEAVY ELECTRICALS LIMITED SUPPLIER REGISTRATION FORM

FORM NO. SRF(I) 01 (INDIAN SUPPLIER)

ANNEXURE-VI

Page 9 of 17

ORGANISATIONAL INFORMATION					
FINANCIAL INFORMATION FOR THE PREVIOUS FOUR YEARS					
9.0	Parameter	Year 1	Year 2	Year 3	Year 4
		(Years in ascending order, Money value in Rs. Lakhs)			
* 9.1	NET WORTH (Share Capital +Reserves)				
	Growth over previous year (%)	-----			
9.2	LONG TERM DEBT / LOAN				
* 9.3	DEBT EQUITY RATIO				
	$\frac{\text{Long term Debt (9.2)}}{\text{Net worth (9.1)}}$				
9.4	INVESTMENT IN: Land & Building				
	Plant & Machinery				
	Other Fixed Assets				
9.5*	NET CURRENT ASSETS				
	1 a) Cash on hand				
	b) Account receivable				
	c) Inventories				
	Total				
	CURRENT LIABILITY				
	2 a) Sundry creditors				
	b) Interest accrued but not due				
	c) Other liabilities				
	Total				
3	* QUICK RATIO				
	$\frac{\text{CA - INVENT. } \{9.5(1)-9.5(1)c\}}{\text{Current liability } \{9.5 (2)\}}$				
* 9.6	SALES				
	Growth over previous year (%)	-----			
* 9.7	PROFIT BEFORE TAX				
	Growth over previous year (%)	-----			
* 9.8	Whether the supplier has been referred to BIFR / NCLT / any other Govt agency (If YES , enclose details)				YES / NO
* 9.9	Whether the supplier is a potential sick company.(If YES , enclose details)				YES / NO
<p>NOTE: 1. Copies of annual accounts (Balance Sheet) for the last four years (or from date of incorporation which ever is less) along with audit report are to be submitted. The above details shall be highlighted in the Balance Sheet.</p> <p>2. Status of Tax assessments done under various laws (Income Tax, VAT/Sales Tax, Excise & Service Tax, Custom) and details of disputes pending, if any, with these authorities to be submitted.</p>					
SUPPLIER'S AUTHORISED SIGNATORY			BHEL CERTIFIED ASSESSOR		

**BHARAT HEAVY ELECTRICALS LIMITED
SUPPLIER REGISTRATION FORM**

FORM NO. SRF(I) 01 (INDIAN SUPPLIER)

ANNEXURE-VI

Page 10 of 17

ORGANISATIONAL INFORMATION

10. LIST OF ENCLOSURES (Tags to be put on enclosures) :

- (i) MEMORANDUM AND ARTICLES OF ASSOCIATION / SOCIETY RULES AND BYE LAWS / PARTNERSHIP DEED/ PROFESSION TAX REGN & MUNICIPAL REGN. : YES / NO
- (ii) Copy of certificate of following:-
- PERMANENT ACCOUNT NO : YES / NO
 - CENTRAL SALES TAX REGN NUMBER : YES / NO
 - STATE SALES TAX / TIN NUMBER : YES / NO
 - EXCISE DUTY REGN NUMBER : YES / NO
 - EXCISE CONTROL CODE NUMBER : YES / NO
 - SERVICE TAX REGN NUMBER : YES / NO
 - REGN NUMBER OF CATEGORY AS PER MSMED ACT : YES / NO
- (iii) ORGANISATION CHART : YES / NO
- (iv) If registered with any other BHEL Unit,
- LETTER OF REGISTRATION WITH BHEL UNIT : YES / NO
 - PROOF OF SUCCESSFUL EXECUTION OF ONE OR MORE PURCHASE ORDERS : YES / NO
- (v) Letter of approval from ASME / NTPC / NPC / EIL / DGS&D / RAILWAYS / IBR / LLOYDS ETC : YES / NO
- (vi) Accreditation certificate for
- ISO: 9001 : YES / NO
 - TOC of Quality System Manual : YES / NO
 - ISO : 14000 : YES / NO
 - OHSAS , ISO 18000 : YES / NO
- (vii) Letter regarding technical collaboration : YES / NO
- (viii) Experience List / Performance certificate : YES / NO
- (ix) Balance Sheet for the last four years along with audit Report : YES / NO
- (x) Principal's authorization in case of dealers/ agents : YES / NO
- (xi) EFT Bank's certificate : YES / NO

I /WE GIVE THE UNDERTAKING THAT BHEL DRAWINGS & SPECIFICATIONs SHALL NOT BE USED IN ANY WAY DETRIMENTAL TO THE INTEREST OF BHEL AND/ OR FOR SUPPLY OF ANY MATERIAL, PRODUCT OR SERVICES DIRECTLY OR INDIRECTLY TO ANY OTHER CUSTOMER.

Maximum Marks = 50

Negative Marks = -13

Minimum Qualifying marks = 30

SUPPLIER'S AUTHORISED SIGNATORY

BHEL CERTIFIED ASSESSOR

**BHARAT HEAVY ELECTRICALS LIMITED
SUPPLIER REGISTRATION FORM**

FORM NO. SRF(I) 01 (INDIAN SUPPLIER)

ANNEXURE-VI

Page 11 of 17

FORM NO. SRF(I) 01

Part B (QUALITY SYSTEM):

Sl. No	PARAMETERS	SYSTEM IN EFFECT (Tick if exists & provide evidences if ticked in written procedure)		RECORDS (Tick if available & submit evidences)	REMARKS
		Written Procedure	Practice		
1*	Incoming Material Control System				Furnish a copy of system and organization.
2*	In process control				Furnish at least one work instruction & record of process control parameter
3*	Manufacturing / Testing Procedure Qualification				Procedure Qualification specification may be submitted
4*	Personnel qualification for 3 above.				Record of Personnel qualification (PQR) to be submitted
5*	Calibration system				Submit list of instrument & their calibration status
6*	System of Identification & Traceability of materials, tools, jigs, fixtures & processed components, etc.				Copy of procedure to be submitted
7*	System of Storage, Preservation, Painting & packing				Copy of procedure to be submitted
8*	System of NCR disposition & corrective preventive action				Two copies of NCR & CAPA
9*	Customer complaints handling system				Submit list of customer complaints & status for the last three years
10*	Safety measures				Submit copy of safety system & Record of accidents for last three years
11	Any other quality initiative				

SUPPLIER'S AUTHORISED SIGNATORY

BHEL CERTIFIED ASSESSOR

**BHARAT HEAVY ELECTRICALS LIMITED
SUPPLIER REGISTRATION FORM**

FORM NO. SRF(I) 01 (INDIAN SUPPLIER)

ANNEXURE-VI

Page 12 of 17

FORM NO. SRF(I) 01

Part B (QUALITY SYSTEM):

12. LIST OF ENCLOSURES

- (i) Copy of system of control incoming materials and organization chart
- (ii) Copy of at least one process control work instruction
- (iii) Record of process control parameter
- (iv) Copy of at least one Procedure Qualification specification
- (v) Record of Personnel qualification (PQR)
- (vi) List of instrument & their calibration status
- (vii) Copy of procedure for Identification & Traceability of materials, tools, jigs, fixtures & processed components, etc.
- (viii) Copy of procedure for Storage/ preservation/ painting & packing
- (ix) Copies of two NCRs and their CAPA.
- (x) List of customer complaints & status for the last three years
- (xi) Copy of safety system
- (xii) Record of accidents for last three years

Maximum Marks = 25

Minimum Qualifying marks = 15

SUPPLIER'S AUTHORISED SIGNATORY

BHEL CERTIFIED ASSESSOR

BHARAT HEAVY ELECTRICALS LIMITED SUPPLIER REGISTRATION FORM

FORM NO. SRF(I) 01 (INDIAN SUPPLIER)

ANNEXURE-VI
Page 13 of 17 amdt.-04

FORM NO. SRF(I)01

Part C: TECHNICAL COMPETENCE

Technical competence shall be evaluated in two parts viz. common competence and product/material category specific competence.

(i) COMMON TECHNICAL COMPETENCE

TECHNICAL COMPETENCE (where design specification is given by BHEL)	MARKING RANGE	Marking range, if product specific technical competency not required	SUPPLIER RESPONSE (ALONG WITH SUPPORTING DOCUMENTS)#	MARKS BY BHEL
1. Supplier understands the product specification.	(0-3)	(0-8)		
2. Supplier understands the inspection requirements.	(0-2)	(0-5)		
3. Supplier has process capability to achieve the product specification/dimensional requirement.	(0-3)	(0-8)		
4. Supplier has experienced manpower to carry out the job.	(0-2)	(0-4)		
TOTAL MARKS OUT OF POSSIBLE	10	25		

OR

TECHNICAL COMPETENCE (where performance specification is given by BHEL)	MARKING RANGE	Marking range, if product specific technical competency not required	PROCEDURE		SYSTEM IN EFFECT		RECORDS	
			SUPPLIER RESPONSE (ALONG WITH SUPPORTING	MARKS BY BHEL	SUPPLIER RESPONSE (ALONG WITH SUPPORTING	MARKS BY BHEL	SUPPLIER RESPONSE (ALONG WITH SUPPORTING	MARKS BY BHEL
1. Design capability	(0-3)	(0-8)						
2. Adequacy of quality assurance plan	(0-2)	(0-5)						
3. Process capability for components	(0-3)	(0-8)						
4. Adequate of testing	(0-2)	(0-4)						
TOTAL MARKS OUT OF POSSIBLE Average of Total (Total/3) = -----	10	25						

(ii) PRODUCT/ MATERIAL CATEGORY SPECIFIC TECHNICAL COMPETENCE

(Max Marks: 15)

Unit MISCC to structure the parameters to be considered for the technical competence depending on material category. The score of individual parameter selected is to be decided by MISCC. MISCC shall identify the requirement of enclosures to be furnished by supplier.

Product:

Sl. No	Material category	Tech Parameter	Supplier's response	Remarks

To be filled up only on receipt of technical requirements/ specification, drawings, standards from BHEL and to be sent to BHEL for further scrutiny. Enclose documentary evidence where ever required.

LIST OF ENCLOSURES:

Maximum Marks = 25

Minimum Qualifying marks = 15

No marks is to be given by the supplier. Only supplier response along with supporting documents.

SUPPLIER'S AUTHORISED SIGNATORY

BHEL CERTIFIED ASSESSOR

BHARAT HEAVY ELECTRICALS LIMITED SUPPLIER REGISTRATION FORM

FORM NO. SRF(I) 01 (INDIAN SUPPLIER)

ANNEXURE-VI

Page 14 of 17

Part D : SCORE SHEET

1. ORGANISATIONAL SOUNDNESS (for Manufacturers):

S.N.	PARAMETER	CRITERIA	Maxm. Marks	Marks Awarded
1.	Whether all relevant information like ownership, PAN no., sales tax no., excise duty no., etc. submitted	Yes: 2 No: 0	2	
2.	3.4 YEAR OF COMMENCEMENT OF BUSINESS	More than 5 years : 2 1-5 years : 1 Less than 1 year : 0	2	
3.	5.1 POWER BACKUP	Yes : 1 No : 0	1	
4.	5.2 DOES THE COMPANY SELL ITS PRODUCT DIRECTLY	Yes : 1 No : 0	1	
5.	6.1 REGISTERED WITH ANY OF BHEL UNITS	Yes (same item) : 2 Yes (another item) : 1 No : 0	2	
6.	6.2 APPROVAL BY ASME/ NTPC/ NPC/ EIL/ DGS&D/ RAILWAYS/ IBR/ LLOYDS ETC	Yes : 2 No : 0	2	
7.	6.3 ISO 9001 ACCREDITATION	Yes : 3 No : 0	3	
8.	6.4 ISO 14000 ACCREDITATION	Yes : 1 No : 0	1	
9.	6.5 OHSAS - 18000 ACCREDITATION	Yes : 1 No : 0	1	
10.	6.6 TECHNICAL COLLABORATOR : (FOREIGN OR INDIGENOUS)	Yes : 1 No : 0	1	
11.	6.7 R & D SET UP	Yes : 1 No : 0	1	
12.	6.12 PENDING LEGAL ISSUES ON TECHNO – COMMERCIAL ASPECTS WITH CUSTOMER	Yes : -5 No : 0	0	
13.	7.1 & 7.2 MANUFACTURING FACILITIES INCLUDING OUTSOURCING	Adequate : 3 Substantial : 2 Inadequate : 0	3	
14.	7.3 RATIO OF OUTSOURCED COST TO TOTAL PRODUCTION VALUE	Less than 10% : 2 10 to 30 % : 1 More than 30% : 0	2	
15.	8.1 INSPECTION & TESTING FACILITIES	Adequate : 2 Substantial : 1 Inadequate : 0	2	
16.	8.2 OUTSOURCING OF MAJOR TESTING FACILITY (Refer Note)	Yes : 0 No : 1	1	
	TOTAL		25	

1. ORGANISATIONAL SOUNDNESS (for Indian Stockist/ Trader/ Distributor/ Dealer/ Authorised Agent/ Channel partner/ Indian Sales office or Subsidiary of registered foreign principal):

S.N.	PARAMETER	CRITERIA	Maxm. Marks	Marks Awarded
1.	Whether all relevant information like ownership, PAN no., sales tax no., etc. submitted (clause 6.0 of chapter V to be referred in this regard)	Yes: 7 No: 0	7	
2.	3.4 YEAR OF COMMENCEMENT OF BUSINESS	More than 3 years : 2 1-3 years : 1 Less than 1 year : 0	2	
3.	6.1 REGISTERED WITH ANY OF BHEL UNITS	Yes (same item) : 2 Yes (another item) : 1 No : 0	2	
4.	6.2 APPROVAL BY ASME/ NTPC/ NPC/ EIL/ DGS&D/ RAILWAYS/ IBR/ LLOYDS ETC	Yes : 2 No : 0	2	
5.	6.3 ISO 9001 ACCREDITATION	Yes : 2 No : 0	2	
6.	6.12 PENDING LEGAL ISSUES ON TECHNO – COMMERCIAL ASPECTS WITH CUSTOMER	Yes : -5 No : 0	0	

BHEL CERTIFIED ASSESSOR

BHARAT HEAVY ELECTRICALS LIMITED SUPPLIER REGISTRATION FORM

FORM NO. SRF(I) 01 (INDIAN SUPPLIER)

ANNEXURE-VI

Page 15 of 17

Part D: SCORE SHEET

2. FINANCIAL INFORMATION (for Manufacturers):

S.N.	PARAMETER	CRITERIA	Maximum Marks	Marks Awarded
1.	9.1 Growth of Net Worth over previous year (%) Average of three years to be worked out	More than 20 % : 5 10 – 20 % : 4 5 – 10 % : 3 > 0 & < 5 % : 2 0 or below : 0	5	
2.	9.3 DEBT EQUITY RATIO <u>Long term Debt (9.2)</u> Net worth (9.1)	1 : 1 : 5 1.1 upto 1.5 : 1 : 4 1.6 upto 2.0 : 1 : 3 2.0 & above : 1 : 2	5	
3.	9.5 QUICK RATIO <u>CA - INVENTORIES {9.5(1)-9.5(1)c}</u> Current liability {9.5 (2)}	1 : 1 : 5 1 : 1 upto 1.5 : 4 1 : 1.5 upto 1.75 : 3 1 : 1.75 upto 2.5 : 2 1 : > 2.5 : 0	5	
4.	9.6 Growth in Sales over previous year (%) Average of three years to be worked out	More than 35% : 5 20 -35 % : 4 10 – 20 % : 3 5 – 10 % : 2 > 0 & < 5 % : 1 0 or negative : 0	5	
5.	9.7 PROFIT BEFORE TAX Growth over previous year (%)	More than 20 % : 5 10 – 20 % : 4 5 – 10 % : 3 > 0 & < 5 % : 2 0 or below : 0	5	
6.	9.8 Whether the supplier has been referred to BIFR / NCLT/ any other similar Govt agency	Yes: -5 No : 0	0	
7.	9.9 Whether the supplier is a potentially sick company	Yes: -3 No : 0	0	
TOTAL			25	

Note: If the supplier is new in business and does not have past data, then the evaluation will be done on the basis of information provided by him and will be decided by MISCC.

2. FINANCIAL INFORMATION (for Indian Stockist/ Trader/ Distributor/ Dealer/ Authorised Agent/ Channel partner/ Indian Sales office or Subsidiary of registered foreign principal):

S.N.	PARAMETER	CRITERIA	Maximum Marks	Marks Awarded
1.	9.6 Growth in Sales over previous year (%) Average of three years to be worked out	More than 35% : 5 20 -35 % : 4 5 - 20 % : 3 >0 - 5 % : 2 0 or negative : 0	5	
2.	9.7 PROFIT BEFORE TAX Growth over previous year (%)	More than 20 % : 5 5 – 20 % : 4 >0 – 5 % : 3 0 or below : 0	5	

BHEL CERTIFIED ASSESSOR

BHARAT HEAVY ELECTRICALS LIMITED SUPPLIER REGISTRATION FORM

FORM NO. SRF(I) 01 (INDIAN SUPPLIER)

ANNEXURE-VI

Page 16 of 17

Part D : SCORE SHEET

3. QUALITY SYSTEM :

S.N.	PARAMETER	CRITERIA	Maxm. Marks	Marks Awarded
1.	Incoming Material control System	System availability : Yes: 1 No : 0	1	
		Availability of Organisation chart Yes: 1 No : 0	1	
2.	Process control	Work instruction available: Yes: 1 No : 0	1	
		Record of process Control : Available : 2 Partial record : 1 Not available: 0	2	
3.	Manufacturing / Testing Procedure Qualification	Procedure Qualification Specification : Adequate : 3 In adequate: 1 Not available : 0	3	
4.	Personnel qualification	Record of PQR: Adequate : 3 In adequate: 1 Not available : 0	3	
5.	Calibration system	Adequate : 3 In adequate: 1 Not available : 0	3	
6.	System of Identification & Traceability of materials, tools, jigs, fixtures & processed components, etc.	Procedure available : Adequate : 2 In adequate: 1 Not available : 0	2	
7.	System of Storage/ preservation/ painting & packing	Procedure available : Adequate : 2 In adequate: 1 Not available : 0	2	
8.	System of NCR disposition & corrective preventive action	Two copies of NCR & CAPA Available :2 Not available : 0	2	
9.	Customer complaints handling system	System available : Yes: 1 No : 0	1	
		Complaints registered & resolved :2 Complaints registered & partially resolved : 1 Complaints not registered or not resolved : 0	2	
10.	Safety measures	System available : Yes: 1 No : 0	1	
		Record available : Yes: 1 No : 0	1	
TOTAL			25	

BHEL CERTIFIED ASSESSOR

BHARAT HEAVY ELECTRICALS LIMITED SUPPLIER REGISTRATION FORM

FORM NO. SRF(I) 01 (INDIAN SUPPLIER)

ANNEXURE-VI
Page 17 of 17 amdt.-04

Part D : SCORE SHEET

4. TECHNICAL COMPETENCE

	Maximum Marks (1)	Marks obtained (2)
A. Common Technical Competence		

And/ or

B. Product Specific Technical Competence

Column no. 1 to 4 to be filled by MISCC before sending to supplier. Column no. 5 to be filled by BHEL certified Assessor after evaluation of supplier response.

Sl. No (1)	Parameter (2)	Scoring criteria (3)	Maximum Marks (4)	Marks obtained (5)
	Sub-Total		15	

TOTAL (A+B): 25 ()

SUMMARY:

Sl. No	Criteria	Maxm Marks	Qualifying marks *	Marks obtained	Recommendation for registration
1.	Organisational Soundness	50	30		Recommended : Permanent code /Development code/ Trial code Not recommended
	Financial Information				
2.	Quality System	25	15		
3.	Technical Competence	25	15		
	TOTAL	100	60		

***Minimum Qualifying Score in Each category shall be 60%.**

REGISTRATION CRITERIA:

Sl. No	Score	Recommendation
1.	More than 90	Supplier is to be registered and given Permanent code, Normally no visit is called for.
2.	>75 <=90	Supplier may be visited if recommended by MISCC or to be registered and given permanent code.
3.	>=60 <=75	Supplier may carry out suggested improvements if advised by MISCC Supplier's visit is mandatory. Trial/ Development code may be given.
4.	Less than 60	Not to be registered

Note: Indian Stockist/ Trader/ Distributor/ Dealer/ Authorised Agent/ Channel partner/ Indian Sales office or Subsidiary of registered foreign principal are to be awarded marks on pro-rata basis and registered accordingly.

Signatures: MISCC and Suppler Evaluation Team (in case of visit)

1) 2) 3)
4) 5) 6)

BHEL CERTIFIED ASSESSOR

ANNEXURE-VII

(Supplier Registration Form Foreign Vendor)



Annexure-VII

**GUIDELINES TO FOREIGN SUPPLIERS
FOR FILLING UP SUPPLIER
REGISTRATION FORM**

Document No.	AA:MM:SR:01
Revision No.	01
Page No.	I of II

1. Prospective Suppliers may also visit our web site www.bhel.com (link Supplier Registration -> New Supplier Required) to know more about the requirement of new suppliers for various items in our units.
2. Registration Form no. SRF(F)01 may be obtained from BHEL website www.bhel.com.
3. Application for registration, with a covering letter detailing where your products can find application (if possible) in BHEL unit(s), should be sent to:

Supplier Development Cell
Unit Name:
Bharat Heavy Electricals Ltd.
City:
India

4. In case registration is being sought in multiple units of BHEL, please send the separate application to each unit.
5. Any clarification with respect to procedure for registration may be obtained from the Supplier Development Cell of respective BHEL unit.
6. All columns are to be filled up properly in the space provided for. Wherever it is not applicable, mention it as "Not Applicable". The form is to be signed by the authorised signatory and submitted in original.
7. Please attach separate sheet if the space provided is insufficient. For any other information also, separate sheet may be attached.
8. Any information / clarification required by BHEL during processing of registration must be given expeditiously.
9. Please ensure that all required enclosures are attached with the filled up Supplier Registration Form and all enclosures are numbered & list of enclosures is given as required.
10. As multiple copies of the application forms are required for processing at our end, please do not spiral bound the application forms or its enclosures and instead send them in two hole clip flat file.
11. Please fill up the check- list given on next page and send along with the Supplier Registration Forms to BHEL.
12. Please note that if you are registered and participate in Tender process and qualify to get order from BHEL, your performance based on Quality of your product, delivery performance and service rendered will be evaluated inline with Chapter VI.
13. If you are attaching a document in a language other than English, a self attested English translated document may please be also attached.

	Annexure-VII CHECK-LIST FOR FOREIGN SUPPLIERS REGISTRATION FORM	Document No.	AA:MM:SR:01
		Revision No.	01
		Page No.	II of II

S.N.	Check-Point	Yes/No
1.0	Information against all points in the Supplier Registration Form has been given.	
2.0	Authorisation letter has been enclosed (in case of Indian representative)	
3.0	Banker's certificate has been enclosed	
4.0	Are you an ISO: 9001 accredited supplier?	
4.1	If yes, have you enclosed copy of ISO 9001 accreditation certificate & "Table of Contents" of your Quality Manual?	
4.2	If no, have you enclosed written down procedure / manual of Quality Management System?	
5.0	Have you enclosed experience list/ performance certificate (as per sl. 3.0 of the form SRF(F) 01)	
6.0	List of enclosures has been furnished (as per Sl 5.0 of the form SRF(F) 01)	
7.0	All the parts of the form & enclosures have been signed by Authorised Signatory.	
8.0	D&B Report/ Creditreform report etc. has been attached.	

Date :

Signature & seal

(Authorised Signatory)

Note : This check list is to be attached with the filled up Supplier Registration Form.

FORM NO. SRF(F)01 : (FOREIGN SUPPLIER)

- 1.8 YEAR OF COMMENCEMENT OF BUSINESS :
- 1.9 PRODUCTION CAPACITY PER ANNUM (details of major manufacturing/ testing facilities to be given) :
- 1.10 PARTICULARS OF PRODUCTS INCLUDING SPECIFICATION AND RANGE OFFERED FOR REGISTRATION : (ATTACH BROCHURES AND CATALOGUES)
- 1.11 NAME (S) OF BANKERS :
- 1.12 BANKER'S CERTIFICATE AS TO CREDITWORTHINESS OF THE CLIENT
(Enclose Certificate) :
- 1.13 PORT OF LOADING :
- 1.14 NEAREST AIRPORT :
- 1.15 Report from D&B/ Creditreform etc. (As per Cl. 7.1 of Chapter V) (**MANDATORY**):

2.0 FINANCIAL INFORMATION : (FOR LAST 3 YEARS)

PARAMETER	YEAR -1	YEAR -2	YEAR -3
ANNUAL TURN OVER			
PROFIT AFTER TAX			

(COPY OF AUDITED ANNUAL ACCOUNTS FOR LAST 3 YEARS TO BE ENCLOSED)

3.0 QUALITY MANAGEMENT SYSTEM :

- 3.1 IS THE COMPANY ISO:9001 CERTIFIED : YES / NO
- 3.1.1 IF YES, ENCLOSE COPY OF CERTIFICATE & TABLE OF CONTENTS OF QUALITY MANUAL.
- 3.1.2 IF NO, ENCLOSE QUALITY MANAGEMENT SYSTEM OR WRITTEN DOWN PROCEDURE

- 4.0 EXPERIENCE LIST/ PERFORMANCE CERTIFICATE FOR OFFERED / SIMILAR ITEMS :**
(ATTACH LIST OF PRESENT CUSTOMERS WITH NAME & ADDRESS FOR OFFERED / SIMILAR TYPE & SIZE OF ITEM / EQUIPMENT FOR WHICH REGISTRATION HAS BEEN SOUGHT AND WITH WHOM YOU HAVE CONTINUOUS BUSINESS SINCE LAST THREE YEARS)

5.0 IF REGISTERED IN ANY OTHER UNIT OF BHEL, PLEASE SPECIFY:**6.0 DIRECTORS / PARTNERS, IF RELATED TO ANY BHEL EMPLOYEE.**

NAME:
STAFF NO.:
DESIGNATION:
UNIT & DEPARTMENT:
RELATIONSHIP:

7.0 ANY OTHER INFORMATION:**8.0 LIST OF ENCLOSURES :**
(BROCHURES, CATALOGUES, TECHNICAL LITERATURE ETC.)

E – Mail

TELEPHONE : (Landline):
 Mobile :

DATE :

Signature & Seal
 AUTHORISED SIGNATORY
 NAME :
 DESIGNATION :

BHEL CERTIFIED ASSESSOR

ANNEXURE-VIII

Quality Plan-Format

MANUFACTURER'S NAME AND ADDRESS		STANDARD QUALITY PLAN				TO BE FILLED BY BHEL		TO BE FILLED BY BHEL					
BHEL	VENDOR'S NAME	ITEM		QP NO.									
				REV									
		DRG. NO.	AS PER PO										
		SPEC. REV	AS PER PO										
Page 1 of 3													
SL. NO.	COMPONENT & OPERATIONS	CHARACTERISTICS	CLASS	TYPE OF CHECK	QUANTUM OF CHECK	REFERENCE DOCUMENT	ACCEPTANCE NORMS	FORMAT OF RECORDS		AGENCY		REMARKS	
1	2	3	4	5	6	7	8	9	D	M	B	N	11

MANUFACTURER/SUBCONTRACTOR	LEGEND	FOR CUSTOMER USE	APPROVED BY
	! RECORDS IDENTIFIED WITH 'TICK' SHALL BE ESSENTIALLY INCLUDED BY CONTRACTOR IN QA DOCUMENTATION. M- MANUFACTURER / SUBCONTRACTOR B- BHEL / NOM INSPECTION AGENCY N- CUSTOMER INDICATE 'P' PERFORM 'W' WITNESS AND 'V' VERIFICATION -- ALL 'W' INDICATED IN COLUMN 'N' SHALL BE 'CHP' OF CUSTOMER		

2

ANNEXURE-IX

Certificate by Chartered Accountant on letter head

This is to Certify that M/s
(hereinafter referred to as 'company') having its registered office atis
registered under MSMED Act 2006, (Entrepreneur Memorandum No (Part- II)
.....dtd:.....,
Category:.....(Micro/Small).(copy enclosed).

Further verified from the Books of Accounts that the investment of the company as
on dateas per MSMED Act 2006 is as follows:

1. **For Manufacturing Enterprises:** Investment in plant and machinery (i.e. original cost excluding land and building and the items specified by the Ministry of Small Scale Industries vide its notification No. S.O.1722(E) dated October 5, 2006:
Rs.....Lacs
2. **For Service Enterprises:** Investment in equipment (original cost excluding land and building and furniture, fittings and other items not directly related to the service rendered or as may be notified under the MSMED act, 2006:
Rs.....Lacs

(Strike off whichever is not applicable)

The above investment of RsLacs is within permissible limit of Rs..... Lacs for
.....micro / small (Strike off which is not applicable) Category under MSMED Act 2006.

Or

The company has been graduated from its original category (Micro / Small) (Strike off whichever is not applicable) and the date of graduation of such enterprises from its original category is
(dd/mm/yyyy) which is within the period of 3 years from the date of graduation of such enterprises from its original category as notified vide S.O. No. 3322(E) dated 01.11.2013 published in the gazette notification dated 04.11.2013 by Ministry of MSME.

Date:

(Signature)

Name-

Membership Number-

Seal of Chartered Accountant

ANNEXURE-X

Process Compliance Form

(The bidders are required to print this on their company's letterhead and sign, stamp before faxing)

To
Name & Address of Service Provider
For Reverse Auction (Will be informed
Later)

Sub: Agreement to the Process related Terms and Conditions

Dear Sir,

This has reference to the Terms & Conditions for the Reverse Auction mentioned in the RFQ document for {Items} against BHEL enquiry/ RFQ no. F/T237/4/4136/H/1.

This letter is to confirm that:

- 1) The undersigned is authorized official/ representative of the company to participate in RA and to sign the related documents.
- 2) We have studied the Reverse Auction Terms & Conditions and the Business rules governing the Reverse Auction as mentioned in your letter and confirm our agreement to them.
- 3) We also confirm that we have taken the training on the auction tool and have understood the functionality of the same thoroughly.
- 4) We also confirm that, in case we become L1 bidder, we will email/ fax the price confirmation & break up of our quoted price (including that of line items) as per *Annexure - VII* within **two** working days (of BHEL) after completion of RA event, besides sending the same by registered post/ courier both to M/s. BHEL and Service provider of Reverse Auction

We, hereby confirm that we will honor the Bids placed by us during the auction process.

With regards

Signature with company seal

Name –
Company / Organization
Designation within Company / Organization
Address of Company / Organization

- Sign this document and Fax it to Service provider of Reverse Auction at 24 Hrs prior to start of the Event.
- Attach a signed copy of the RFQ document along with the Agreement Form/ Process Compliance form and send to Service provider of Reverse Auction.

ANNEXURE-XI

RA price confirmation and breakup

To

Name & Address of Service Provider
For Reverse Auction (Will be informed
Later)

CC: M/s BHEL
Heavy Electricals Equipment Plant, Haridwar

Sub: **Final price quoted during Reverse Auction and price breakup**

Dear Sir,

We confirm that we have quoted.

Rs.{ } for item covered under tender enquiry No. F/T237/4/4136H/1.

Total price of the items covered under above cited enquiries is inclusive of
{Packing & forwarding, E.D., C.S.T., freight and insurance charges up to
BHEL Haridwar District Haridwar stat- Uttarakhand and Type Test Charges etc., (exclusive of
service tax), other as per NIT}

as our final landed prices as quoted during the Reverse Auction conducted today
{date} which will be valid for a period of 60 days.

The price break-up including that of line items is as given below.

Total -Rs. =====
=====

Thanking you and looking forward to the valuable order from BHEL.

Yours sincerely,

For _____

Name: Company:

Date:

Seal:

ANNEXURE-XII

Drawing – 21660570032 Var-00 Rev-00

Drawing – 21660170058 Var-00 Rev-01

COPYRIGHT AND CONFIDENTIAL
 THE INFORMATION ON THIS DOCUMENT IS THE PROPERTY OF BHARAT HEAVY ELECTRICALS LIMITED. IT MUST NOT BE USED DIRECTLY OR INDIRECTLY IN ANY WAY DETERIMENTAL TO THE INTEREST OF THE COMPANY.

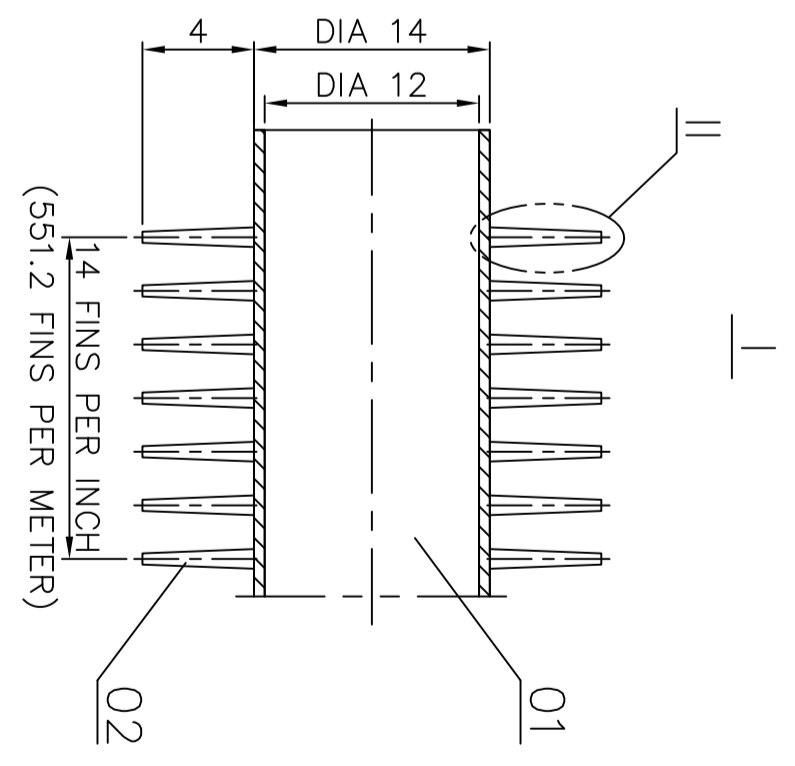
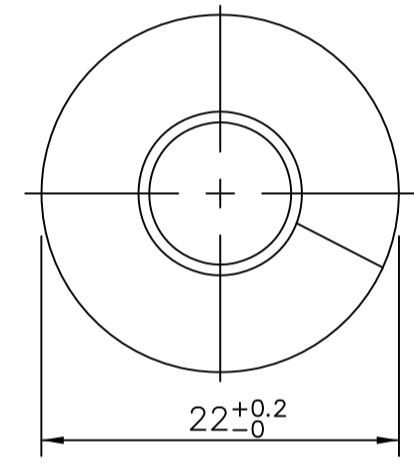
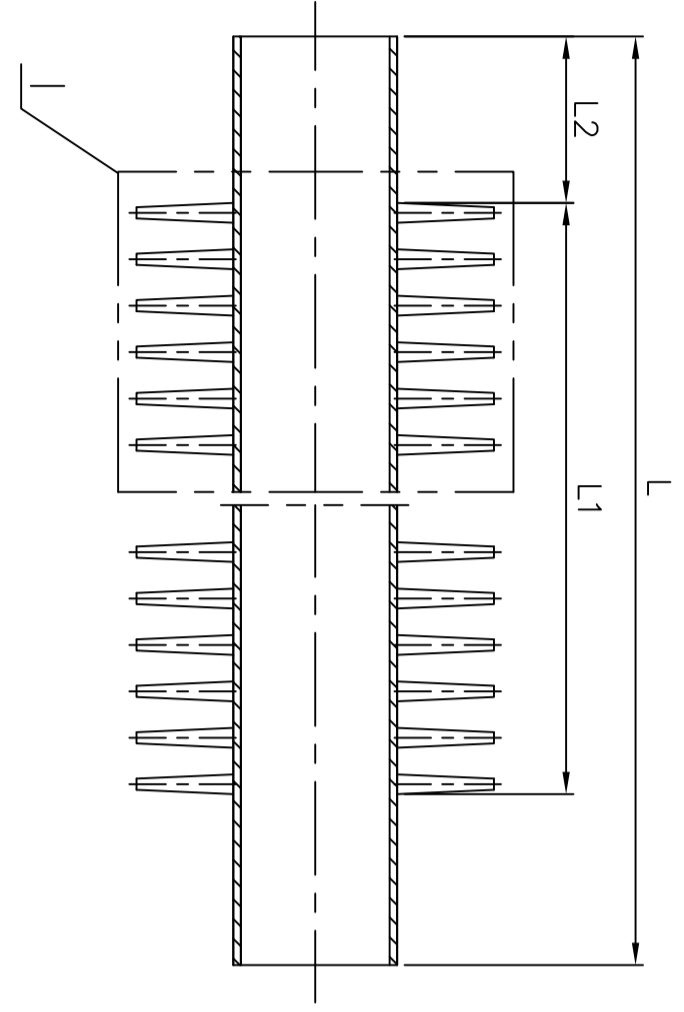
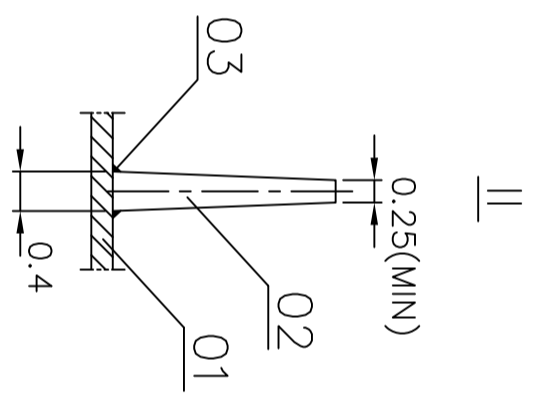

TABLE:-

VAR.	L		L2	TOTAL WT. (Kg)	REF. GMS/ CBOM NO.
	CODE NO.	L1			
00	W96716601570	2526±3	2469±3	28	1.90
	HE57065				

03	SOLDER WIRE	IS:1921 Gr.35
02	FIN	CU
01	BASE TUBE	90:10 CU-NI
ITEM NO.	DESCRIPTION	MATERIAL



TECHNICAL REQUIREMENTS:-

- HIGH FINNED TUBES SHALL BE SUPPLIED WITH BASE TUBE DIA 16X1 mm OF 90/10 CU NI MATERIAL AND FINN MADE FROM 0.4 mm THICK CONTINUOUS COPPER SHEET WRAPPED ON THE TUBE.
- ROOT OF FIN TO BE SOLDERED WITH BASE TUBE.
- SOLDER WIRE SHALL CONFIRM TO IS:1921 Gr. 35.
- THE BONDING OF FINN TO BASE TUBE SHOULD BE PERFECT WITH OUT AIR GAP FOR EFFECTIVE HEAT TRANSFER. THE BONDING SHALL ALSO ,BE MECHANICALLY STRONG AND ROBUST TO MAKE THE TUBE SUITABLE FOR THER USE IN AIR COOLERS OF HIGH RATING THERMAL T.G. SET. IF NECESSARY BASE TUBES CAN BE TINNED FOR PROPER BONDING/ SOLDERING .
- THE TUBES SHALL BE SUPPLIED EXACTLY AS PER GEOMETRICAL DETAIL AS INDICATED IN DRAWING.
- 90/10 CUPPRO-NICKEL BASE TUBE SHALL CONFIRM EXACTLY TO OUR SPECIFICATION NO. AA12130. ALL TEST CERTIFICATES (CHEMICAL, MECH,HYD. TEST ETC.)
- THE FINN SHALL BE MADE FORM 99.9% COPPER.
- THE FINNED TUBE SHALL CONFIRM TO SPECIFICATION HE57065.
- 100% TUBES SHALL BE SUBJECTED TO HYDRAULIC TEST AS PER HE57065.
- TUBES ENDS SHALL BE FREE FROM SOLDER MATERIAL, CHEMICAL ETC. FOR DIRECT USE FOR ROLLER EXPANSION.
- TUBES SHALL BE PACKED SUITABLY TO AVOID ANY DAMAGE OF TUBE DURING HANDLING TRANSPORTATION AND STORAGE.
- ONE SAMPLE OF EACH TYPE TO BE TESTED FOR BONDING STRENGTH BETWEEN, FIN AND TUBE AS PER BHEL APPROVED PROCEDURE.

NOTE:-
 ONE NUMBER OF 90/10 CUPPRO-NICKEL BASE TUBE OF LENGTH 1.5M IS TO BE SUPPLIED FOR THE LOT OF 150 TUBES.

Asd'ya ivamgaadom ka voga- GRADE OF UNTOLERANCED DIMENSION		sd'hol' Aoo'emo' /C.B.O.M. 01660570032		mras'at' st' status of rsk. U	
masalimaga 'ee0230208' emma MACHINING - AA0230208 m		samt' nagaas' 01660570032		samt' nagaas' 01660570032	
voolidmaga 'ee0621104 ki Eoanai bai WELDING-CLASS 'B' OF AA0621104		WT.		BLMENA sd/-	
gosaq kitmaga 'ee0621101 ki saonai' 3 GAS CUTTING-TABLE 3 OF AA0621101		REV.		DATE	

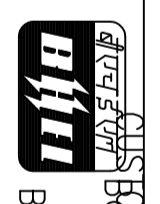

660 MW
 EXCITER AIR COOLER
 BHARAT HEAVY ELECTRICALS LIMITED.
 RANIPUR, HARYANA
 Anuppt./SCALE

saarmaga/1 saUcal saM#yaa/INVENTORY NO.	hatavar AaOr idnalmak/SIGN & DATE	saMdiBa-t Aibakip saM#yaa /REFERENCE DRG.NO.	sva%vaaiQakar evaM gaapnalya [sa p'ook maom di ga[- saUcanaa Baart hoval [laai@T/ki/a ilaimaToD ki sampi-ka hO . [saka p'yaxa yaa Ap'yaxa \$p maom iksal Bal trh p'yaaga nahim ikyaa jaae jaae kmpnal ka iht maom hainakr hap .
8	7	6	5
Saiya-k/TITLE		FINNED TUBE	
kad-Aibakip saM#yaa/DRAWING NO.		KOD/ CARD 7 21660570032	
kad-Aibakip saM#yaa/INVENTORY NO.		KOD/ CARD 7 21660570032	

COPYRIGHT AND CONFIDENTIAL THE INFORMATION ON THIS DOCUMENT IS THE PROPERTY OF BHARAT HEAVY ELECTRICALS LIMITED. IT MUST NOT BE USED DIRECTLY OR INDIRECTLY IN ANY WAY DETERIMENTAL TO THE INTEREST OF THE COMPANY.

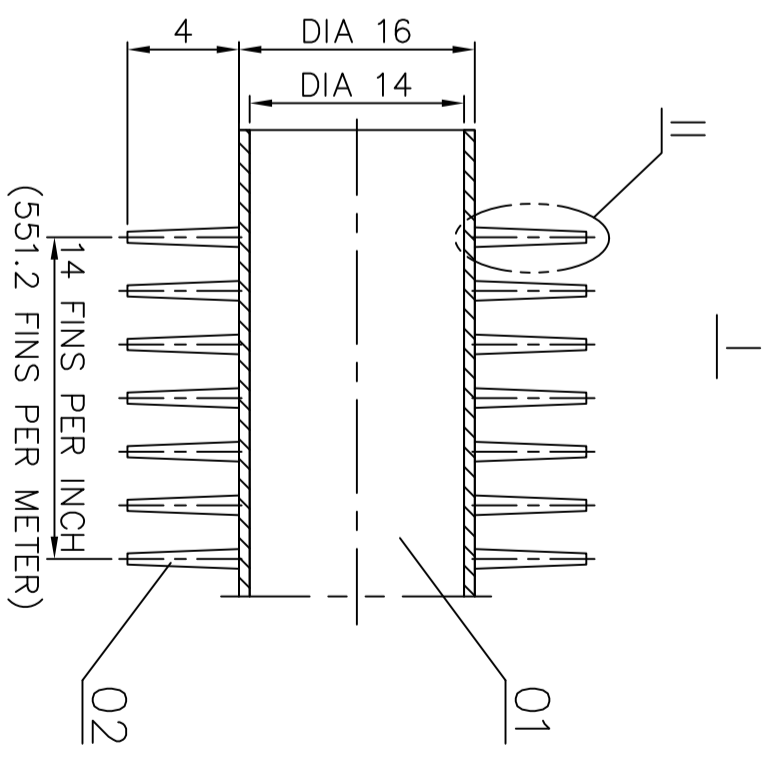
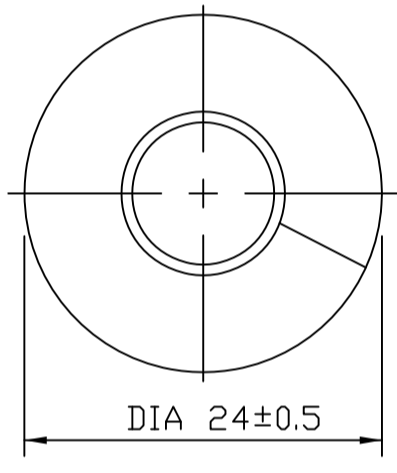
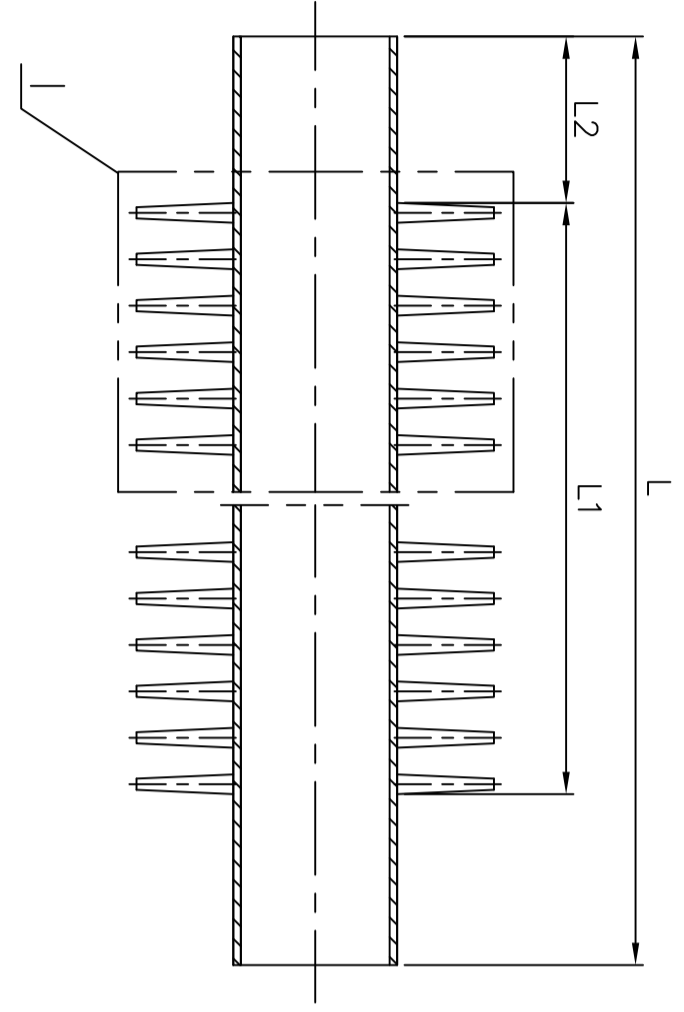
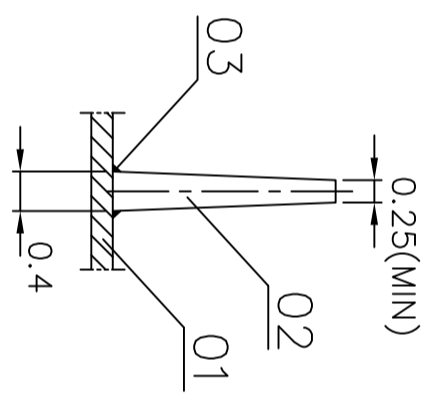

TABLE: -

VAR.	L	L1	L2	TOTAL WT. (Kg)	REF. GMS / CBOM NO.
00	W96716601490	3971-±3	3893-±3	39	3.296
	HE57065				01660170026
01	W96716601503	4391-±3	4313-±3	39	3.647
	HE57065				01660170027



TECHNICAL REQUIREMENTS: -

- HIGH FINNED TUBES SHALL BE SUPPLIED WITH BASE TUBE DIA 16X1 mm OF 90/10 Cu Ni MATERIAL AND FINN MADE FROM 0.4 mm THICK CONTINUOUS COPPER SHEET WRAPPED ON THE TUBE.
- ROOT OF FIN TO BE SOLDERED WITH BASE TUBE.
- SOLDER WIRE SHALL CONFIRM TO IS:1921 Gr. 35.
- THE BONDING OF FINN TO BASE TUBE SHOULD BE PERFECT WITH OUT AIR GAP FOR EFFECTIVE HEAT TRANSFER. THE BONDING SHALL ALSO ,BE MECHANICALLY STRONG AND ROBUST TO MAKE THE TUBE SUITABLE FOR THER USE IN AIR COOLERS OF HIGH RATING THERMAL T.G. SET. IF NECESSARY BASE TUBES CAN BE TINNED FOR PROPER BONDING/ SOLDERING .
- THE TUBES SHALL BE SUPPLIED EXACTLY AS PER GEOMETRICAL DETAIL AS INDICATED IN DRAWING.
- 90/10 CUPRO-NICKLE BASE TUBE SHALL CONFIRM EXACTLY TO OUR SPECIFICATION NO. AA12130. ALL TEST CERTIFICATES (CHEMICAL, MECH,HYD. TEST ETC.)
- THE FINN SHALL BE MADE FORM 99.9% COPPER.
- THE FINNED TUBE SHALL CONFIRM TO SPECIFICATION HE57065.
- 100% TUBES SHALL BE SUBJECTED TO HYDRAULIC TEST AS PER HE57065.
- TUBES ENDS SHALL BE FREE FROM SOLDER MATERIAL, CHEMICAL ETC. FOR DIRECT USE FOR ROLLER EXPANSION.
- TUBES SHALL BE PACKED SUITABLY TO AVOID ANY DAMAGE OF TUBE DURING HANDLING TRANSPORTATION AND STORAGE.
- ONE SAMPLE OF EACH TYPE TO BE TESTED FOR BONDING STRENGTH BETWEEN, FIN AND TUBE AS PER BHEL APPROVED PROCEDURE.

ITEM NO.	DESCRIPTION	MATERIAL
03	SOLDER WIRE	IS:1921 Gr.35
02	FIN	CU
01	BASE TUBE	90:10 CU-NI

Asa'ya ivamoaAoom ka voga- GRADE OF UNTOLERANCED DIMENSION mosalimaga 'ee0230208' emma MACHINING - AA0230208 m voolidmaga 'ee0621104 ki Eoanai bai WELDING-CLASS 'B' OF AA0621104 g00sq KITMga 'ee0621101 ki saarNai 3 GAS CUTTING-TABLE 3 OF AA0621101

sd'hol' Aoo'emo' /C.B.O.M. 01660170026 samai' ooboo' hoomo/NAME 'ASHISH' hanoor/ idnoak/DATE

sd'hol' Aoo'emo' /C.B.O.M. 01660170026 samai' ooboo' hoomo/NAME 'ASHISH' hanoor/ idnoak/DATE

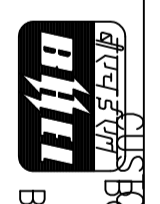

BHARAT HEAVY ELECTRICALS LIMITED. RANIPUR, HARYANA. Anuppt./SCALE

saamaga/1 saUcal saM#yaa/INVENTORY NO.	hatovar AaOr idnaMak/SIGN & DATE	saMdiBa-t Aibakip saM#yaa /REFERENCE DRG.NO.	sva%vaaiQakar evaM gaapnalya [sa p'loak maom di ga- saUcanaa Baart hoval [laai@T/ki sa ilaimaToD ki sampi-ka hO . [saka p'yaxa yaa Ap'yaxa p'p maom iksal Bal trh p'yaaga nahim ikyaa jaee jaao kmpnal ka iht maom hainakr hap .
8	7	6	5
Sd'hol' Aoo'emo' /C.B.O.M. 01660170026 samai' ooboo' hoomo/NAME 'ASHISH' hanoor/ idnoak/DATE WT. - - - - - sd/- - - - - WT. UPDATED HTX-13-F0152 A.K.		Sd'hol' Aoo'emo' /C.B.O.M. 01660170026 samai' ooboo' hoomo/NAME 'ASHISH' hanoor/ idnoak/DATE WT. - - - - - sd/- - - - - HTX-13-F0152 A.K.	
Sd'hol' Aoo'emo' /C.B.O.M. 01660170026 samai' ooboo' hoomo/NAME 'ASHISH' hanoor/ idnoak/DATE WT. - - - - - sd/- - - - - HTX-13-F0152 A.K.		Sd'hol' Aoo'emo' /C.B.O.M. 01660170026 samai' ooboo' hoomo/NAME 'ASHISH' hanoor/ idnoak/DATE WT. - - - - - sd/- - - - - HTX-13-F0152 A.K.	
Sd'hol' Aoo'emo' /C.B.O.M. 01660170026 samai' ooboo' hoomo/NAME 'ASHISH' hanoor/ idnoak/DATE WT. - - - - - sd/- - - - - HTX-13-F0152 A.K.		Sd'hol' Aoo'emo' /C.B.O.M. 01660170026 samai' ooboo' hoomo/NAME 'ASHISH' hanoor/ idnoak/DATE WT. - - - - - sd/- - - - - HTX-13-F0152 A.K.	
Sd'hol' Aoo'emo' /C.B.O.M. 01660170026 samai' ooboo' hoomo/NAME 'ASHISH' hanoor/ idnoak/DATE WT. - - - - - sd/- - - - - HTX-13-F0152 A.K.		Sd'hol' Aoo'emo' /C.B.O.M. 01660170026 samai' ooboo' hoomo/NAME 'ASHISH' hanoor/ idnoak/DATE WT. - - - - - sd/- - - - - HTX-13-F0152 A.K.	
Sd'hol' Aoo'emo' /C.B.O.M. 01660170026 samai' ooboo' hoomo/NAME 'ASHISH' hanoor/ idnoak/DATE WT. - - - - - sd/- - - - - HTX-13-F0152 A.K.		Sd'hol' Aoo'emo' /C.B.O.M. 01660170026 samai' ooboo' hoomo/NAME 'ASHISH' hanoor/ idnoak/DATE WT. - - - - - sd/- - - - - HTX-13-F0152 A.K.	
Sd'hol' Aoo'emo' /C.B.O.M. 01660170026 samai' ooboo' hoomo/NAME 'ASHISH' hanoor/ idnoak/DATE WT. - - - - - sd/- - - - - HTX-13-F0152 A.K.		Sd'hol' Aoo'emo' /C.B.O.M. 01660170026 samai' ooboo' hoomo/NAME 'ASHISH' hanoor/ idnoak/DATE WT. - - - - - sd/- - - - - HTX-13-F0152 A.K.	
Sd'hol' Aoo'emo' /C.B.O.M. 01660170026 samai' ooboo' hoomo/NAME 'ASHISH' hanoor/ idnoak/DATE WT. - - - - - sd/- - - - - HTX-13-F0152 A.K.		Sd'hol' Aoo'emo' /C.B.O.M. 01660170026 samai' ooboo' hoomo/NAME 'ASHISH' hanoor/ idnoak/DATE WT. - - - - - sd/- - - - - HTX-13-F0152 A.K.	
Sd'hol' Aoo'emo' /C.B.O.M. 01660170026 samai' ooboo' hoomo/NAME 'ASHISH' hanoor/ idnoak/DATE WT. - - - - - sd/- - - - - HTX-13-F0152 A.K.		Sd'hol' Aoo'emo' /C.B.O.M. 01660170026 samai' ooboo' hoomo/NAME 'ASHISH' hanoor/ idnoak/DATE WT. - - - - - sd/- - - - - HTX-13-F0152 A.K.	
Sd'hol' Aoo'emo' /C.B.O.M. 01660170026 samai' ooboo' hoomo/NAME 'ASHISH' hanoor/ idnoak/DATE WT. - - - - - sd/- - - - - HTX-13-F0152 A.K.		Sd'hol' Aoo'emo' /C.B.O.M. 01660170026 samai' ooboo' hoomo/NAME 'ASHISH' hanoor/ idnoak/DATE WT. - - - - - sd/- - - - - HTX-13-F0152 A.K.	
Sd'hol' Aoo'emo' /C.B.O.M. 01660170026 samai' ooboo' hoomo/NAME 'ASHISH' hanoor/ idnoak/DATE WT. - - - - - sd/- - - - - HTX-13-F0152 A.K.		Sd'hol' Aoo'emo' /C.B.O.M. 01660170026 samai' ooboo' hoomo/NAME 'ASHISH' hanoor/ idnoak/DATE WT. - - - - - sd/- - - - - HTX-13-F0152 A.K.	
Sd'hol' Aoo'emo' /C.B.O.M. 01660170026 samai' ooboo' hoomo/NAME 'ASHISH' hanoor/ idnoak/DATE WT. - - - - - sd/- - - - - HTX-13-F0152 A.K.		Sd'hol' Aoo'emo' /C.B.O.M. 01660170026 samai' ooboo' hoomo/NAME 'ASHISH' hanoor/ idnoak/DATE WT. - - - - - sd/- - - - - HTX-13-F0152 A.K.	
Sd'hol' Aoo'emo' /C.B.O.M. 01660170026 samai' ooboo' hoomo/NAME 'ASHISH' hanoor/ idnoak/DATE WT. - - - - - sd/- - - - - HTX-13-F0152 A.K.		Sd'hol' Aoo'emo' /C.B.O.M. 01660170026 samai' ooboo' hoomo/NAME 'ASHISH' hanoor/ idnoak/DATE WT. - - - - - sd/- - - - - HTX-13-F0152 A.K.	
Sd'hol' Aoo'emo' /C.B.O.M. 01660170026 samai' ooboo' hoomo/NAME 'ASHISH' hanoor/ idnoak/DATE WT. - - - - - sd/- - - - - HTX-13-F0152 A.K.		Sd'hol' Aoo'emo' /C.B.O.M. 01660170026 samai' ooboo' hoomo/NAME 'ASHISH' hanoor/ idnoak/DATE WT. - - - - - sd/- - - - - HTX-13-F0152 A.K.	
Sd'hol' Aoo'emo' /C.B.O.M. 01660170026 samai' ooboo' hoomo/NAME 'ASHISH' hanoor/ idnoak/DATE WT. - - - - - sd/- - - - - HTX-13-F0152 A.K.		Sd'hol' Aoo'emo' /C.B.O.M. 01660170026 samai' ooboo' hoomo/NAME 'ASHISH' hanoor/ idnoak/DATE WT. - - - - - sd/- - - - - HTX-13-F0152 A.K.	
Sd'hol' Aoo'emo' /C.B.O.M. 01660170026 samai' ooboo' hoomo/NAME 'ASHISH' hanoor/ idnoak/DATE WT. - - - - - sd/- - - - - HTX-13-F0152 A.K.		Sd'hol' Aoo'emo' /C.B.O.M. 01660170026 samai' ooboo' hoomo/NAME 'ASHISH' hanoor/ idnoak/DATE WT. - - - - - sd/- - - - - HTX-13-F0152 A.K.	
Sd'hol' Aoo'emo' /C.B.O.M. 01660170026 samai' ooboo' hoomo/NAME 'ASHISH' hanoor/ idnoak/DATE WT. - - - - - sd/- - - - - HTX-13-F0152 A.K.		Sd'hol' Aoo'emo' /C.B.O.M. 01660170026 samai' ooboo' hoomo/NAME 'ASHISH' hanoor/ idnoak/DATE WT. - - - - - sd/- - - - - HTX-13-F0152 A.K.	
Sd'hol' Aoo'emo' /C.B.O.M. 01660170026 samai' ooboo' hoomo/NAME 'ASHISH' hanoor/ idnoak/DATE WT. - - - - - sd/- - - - - HTX-13-F0152 A.K.		Sd'hol' Aoo'emo' /C.B.O.M. 01660170026 samai' ooboo' hoomo/NAME 'ASHISH' hanoor/ idnoak/DATE WT. - - - - - sd/- - - - - HTX-13-F0152 A.K.	
Sd'hol' Aoo'emo' /C.B.O.M. 01660170026 samai' ooboo' hoomo/NAME 'ASHISH' hanoor/ idnoak/DATE WT. - - - - - sd/- - - - - HTX-13-F0152 A.K.		Sd'hol' Aoo'emo' /C.B.O.M. 01660170026 samai' ooboo' hoomo/NAME 'ASHISH' hanoor/ idnoak/DATE WT. - - - - - sd/- - - - - HTX-13-F0152 A.K.	
Sd'hol' Aoo'emo' /C.B.O.M. 01660170026 samai' ooboo' hoomo/NAME 'ASHISH' hanoor/ idnoak/DATE WT. - - - - - sd/- - - - - HTX-13-F0152 A.K.		Sd'hol' Aoo'emo' /C.B.O.M. 01660170026 samai' ooboo' hoomo/NAME 'ASHISH' hanoor/ idnoak/DATE WT. - - - - - sd/- - - - - HTX-13-F0152 A.K.	
Sd'hol' Aoo'emo' /C.B.O.M. 01660170026 samai' ooboo' hoomo/NAME 'ASHISH' hanoor/ idnoak/DATE WT. - - - - - sd/- - - - - HTX-13-F0152 A.K.		Sd'hol' Aoo'emo' /C.B.O.M. 01660170026 samai' ooboo' hoomo/NAME 'ASHISH' hanoor/ idnoak/DATE WT. - - - - - sd/- - - - - HTX-13-F0152 A.K.	
Sd'hol' Aoo'emo' /C.B.O.M. 01660170026 samai' ooboo' hoomo/NAME 'ASHISH' hanoor/ idnoak/DATE WT. - - - - - sd/- - - - - HTX-13-F0152 A.K.		Sd'hol' Aoo'emo' /C.B.O.M. 01660170026 samai' ooboo' hoomo/NAME 'ASHISH' hanoor/ idnoak/DATE WT. - - - - - sd/- - - - - HTX-13-F0152 A.K.	
Sd'hol' Aoo'emo' /C.B.O.M. 01660170026 samai' ooboo' hoomo/NAME 'ASHISH' hanoor/ idnoak/DATE WT. - - - - - sd/- - - - - HTX-13-F0152 A.K.		Sd'hol' Aoo'emo' /C.B.O.M. 01660170026 samai' ooboo' hoomo/NAME 'ASHISH' hanoor/ idnoak/DATE WT. - - - - - sd/- - - - - HTX-13-F0152 A.K.	
Sd'hol' Aoo'emo' /C.B.O.M. 01660170026 samai' ooboo' hoomo/NAME 'ASHISH' hanoor/ idnoak/DATE WT. - - - - - sd/- - - - - HTX-13-F0152 A.K.		Sd'hol' Aoo'emo' /C.B.O.M. 01660170026 samai' ooboo' hoomo/NAME 'ASHISH' hanoor/ idnoak/DATE WT. - - - - - sd/- - - - - HTX-13-F0152 A.K.	
Sd'hol' Aoo'emo' /C.B.O.M. 01660170026 samai' ooboo' hoomo/NAME 'ASHISH' hanoor/ idnoak/DATE WT. - - - - - sd/- - - - - HTX-13-F0152 A.K.		Sd'hol' Aoo'emo' /C.B.O.M. 01660170026 samai' ooboo' hoomo/NAME 'ASHISH' hanoor/ idnoak/DATE WT. - - - - - sd/- - - - - HTX-13-F0152 A.K.	
Sd'hol' Aoo'emo' /C.B.O.M. 01660170026 samai' ooboo' hoomo/NAME 'ASHISH' hanoor/ idnoak/DATE WT. - - - - - sd/- - - - - HTX-13-F0152 A.K.		Sd'hol' Aoo'emo' /C.B.O.M. 01660170026 samai' ooboo' hoomo/NAME 'ASHISH' hanoor/ idnoak/DATE WT. - - - - - sd/- - - - - HTX-13-F0152 A.K.	
Sd'hol' Aoo'emo' /C.B.O.M. 01660170026 samai' ooboo' hoomo/NAME 'ASHISH' hanoor/ idnoak/DATE WT. - - - - - sd/- - - - - HTX-13-F0152 A.K.		Sd'hol' Aoo'emo' /C.B.O.M. 01660170026 samai' ooboo' hoomo/NAME 'ASHISH' hanoor/ idnoak/DATE WT. - - - - - sd/- - - - - HTX-13-F0152 A.K.	
Sd'hol' Aoo'emo' /C.B.O.M. 01660170026 samai' ooboo' hoomo/NAME 'ASHISH' hanoor/ idnoak/DATE WT. - - - - - sd/- - - - - HTX-13-F0152 A.K.		Sd'hol' Aoo'emo' /C.B.O.M. 01660170026 samai' ooboo' hoomo/NAME 'ASHISH' hanoor/ idnoak/DATE WT. - - - - - sd/- - - - - HTX-13-F0152 A.K.	
Sd'hol' Aoo'emo' /C.B.O.M. 01660170026 samai' ooboo' hoomo/NAME 'ASHISH' hanoor/ idnoak/DATE WT. - - - - - sd/- - - - - HTX-13-F0152 A.K.		Sd'hol' Aoo'emo' /C.B.O.M. 01660170026 samai' ooboo' hoomo/NAME 'ASHISH' hanoor/ idnoak/DATE WT. - - - - - sd/- - - - - HTX-13-F0152 A.K.	
Sd'hol' Aoo'emo' /C.B.O.M. 01660170026 samai' ooboo' hoomo/NAME 'ASHISH' hanoor/ idnoak/DATE WT. - - - - - sd/- - - - - HTX-13-F0152 A.K.		Sd'hol' Aoo'emo' /C.B.O.M. 01660170026 samai' ooboo' hoomo/NAME 'ASHISH' hanoor/ idnoak/DATE WT. - - - - - sd/- - - - - HTX-13-F0152 A.K.	
Sd'hol' Aoo'emo' /C.B.O.M. 01660170026 samai' ooboo' hoomo/NAME 'ASHISH' hanoor/ idnoak/DATE WT. - - - - - sd/- - - - - HTX-13-F0152 A.K.		Sd'hol' Aoo'emo' /C.B.O.M. 01660170026 samai' ooboo' hoomo/NAME 'ASHISH' hanoor/ idnoak/DATE WT. - - - - - sd/- - - - - HTX-13-F0152 A.K.	
Sd'hol' Aoo'emo' /C.B.O.M. 01660170026 samai' ooboo' hoomo/NAME 'ASHISH' hanoor/ idnoak/DATE WT. - - - - - sd/- - - - - HTX-13-F0152 A.K.		Sd'hol' Aoo'emo' /C.B.O.M. 01660170026 samai' ooboo' hoomo/NAME 'ASHISH' hanoor/ idnoak/DATE WT. - - - - - sd/- - - - - HTX-13-F0152 A.K.	
Sd'hol' Aoo'emo' /C.B.O.M. 01660170026 samai' ooboo' hoomo/NAME 'ASHISH' hanoor/ idnoak/DATE WT. - - - - - sd/- - - - - HTX-13-F0152 A.K.		Sd'hol' Aoo'emo' /C.B.O.M. 01660170026 samai' ooboo' hoomo/NAME 'ASHISH' hanoor/ idnoak/DATE WT. - - - - - sd/- - - - - HTX-13-F0152 A.K.	
Sd'hol' Aoo'emo' /C.B.O.M. 01660170026 samai' ooboo' hoomo/NAME 'ASHISH' hanoor/ idnoak/DATE WT. - - - - - sd/- - - - - HTX-13-F0152 A.K.		Sd'hol' Aoo'emo' /C.B.O.M. 01660170026 samai' ooboo' hoomo/NAME 'ASHISH' hanoor/ idnoak/DATE WT. - - - - - sd/- - - - - HTX-13-F0152 A.K.	
Sd'hol' Aoo'emo' /C.B.O.M. 01660170026 samai' ooboo' hoomo/NAME 'ASHISH' hanoor/ idnoak/DATE WT. - - - - - sd/- - - - - HTX-13-F0152 A.K.		Sd'hol' Aoo'emo' /C.B.O.M. 01660170026 samai' ooboo' hoomo/NAME 'ASHISH' hanoor/ idnoak/DATE WT. - - - - - sd/- - - - - HTX-13-F0152 A.K.	
Sd'hol' Aoo'emo' /C.B.O.M. 01660170026 samai' ooboo' hoomo/NAME 'ASHISH' hanoor/ idnoak/DATE WT. - - - - - sd/- - - - - HTX-13-F0152 A.K.		Sd'hol' Aoo'emo' /C.B.O.M. 01660170026 samai' ooboo' hoomo/NAME 'ASHISH' hanoor/ idnoak/DATE WT. - - - - - sd/- - - - - HTX-13-F0152 A.K.	
Sd'hol' Aoo'emo' /C.B.O.M. 01660170026 samai' ooboo' hoomo/NAME 'ASHISH' hanoor/ idnoak/DATE WT. - - - - - sd/- - - - - HTX-13-F0152 A.K.		Sd'hol' Aoo'emo' /C.B.O.M. 01660170026 samai' ooboo' hoomo/NAME 'ASHISH' hanoor/ idnoak/DATE WT. - - - - - sd/- - - - - HTX-13-F0152 A.K.	
Sd'hol' Aoo'emo' /C.B.O.M. 01660170026 samai' ooboo' hoomo/NAME 'ASHISH' hanoor/ idnoak/DATE WT. - - - - - sd/- - - - - HTX-13-F0152 A.K.		Sd'hol' Aoo'emo' /C.B.O.M. 01660170026 samai' ooboo' hoomo/NAME 'ASHISH' hanoor/ idnoak/DATE WT. - - - - - sd/- - - - - HTX-13-F0152 A.K.	
Sd'hol' Aoo'emo' /C.B.O.M. 01660170026 samai' ooboo' hoomo/NAME 'ASHISH' hanoor/ idnoak/DATE WT. - - - - - sd/- - - - - HTX-13-F0152 A.K.		Sd'hol' Aoo'emo' /C.B.O.M. 01660170026 samai' ooboo' hoomo/NAME 'ASHISH' hanoor/ idnoak/DATE WT. - - - - - sd/- - - - - HTX-13-F0152 A.K.	
Sd'hol' Aoo'emo' /C.B.O.M. 01660170026 samai' ooboo' hoomo/NAME 'ASHISH' hanoor/ idnoak/DATE WT. - - - - - sd/- - - - - HTX-13-F0152 A.K.		Sd'hol' Aoo'emo' /C.B.O.M. 01660170026 samai' ooboo' hoomo/NAME 'ASHISH' hanoor/ idnoak/DATE WT. - - - - - sd/- - - - - HTX-13-F0152 A.K.	
Sd'hol' Aoo'emo' /C.B.O.M. 01660170026 samai' ooboo' hoomo/NAME 'ASHISH' hanoor/ idnoak/DATE WT. - - - - - sd/- - - - - HTX-13-F0152 A.K.		Sd'hol' Aoo'emo' /C.B.O.M. 01660170026 samai' ooboo' hoomo/NAME 'ASHISH' hanoor/ idnoak/DATE WT. - - - - - sd/- - - - - HTX-13-F0152 A.K.	
Sd'hol' Aoo'emo' /C.B.O.M. 01660170026 samai' ooboo' hoomo/NAME 'ASHISH' hanoor/ idnoak/DATE WT. - - - - - sd/- - - - - HTX-13-F0152 A.K.		Sd'hol' Aoo'emo' /C.B.O.M. 01660170026 samai' ooboo' hoomo/NAME 'ASHISH' hanoor/ idnoak/DATE WT. - - - - - sd/- - - - - HTX-13-F0152 A.K.	
Sd'hol' Aoo'emo' /C.B.O.M. 01660170026 samai' ooboo' hoomo/NAME 'ASHISH' hanoor/ idnoak/DATE WT. - - - - - sd/- - - - - HTX-13-F0152 A.K.		Sd'hol' Aoo'emo' /C.B.O.M. 01660170026 samai' ooboo' hoomo/NAME 'ASHISH' hanoor/ idnoak/DATE WT. - - - - - sd/- - - - - HTX-13-F0152 A.K.	
Sd'hol' Aoo'emo' /C.B.O.M. 01660170026 samai' ooboo' hoomo/NAME 'ASHISH' hanoor/ idnoak/DATE WT. - - - - - sd/- - - - - HTX-13-F0152 A.K.		Sd'hol' Aoo'emo' /C.B.O.M. 01660170026 samai' ooboo' hoomo/NAME 'ASHISH' hanoor/ idnoak/DATE WT. - - - - - sd/- - - - - HTX-13-F0152 A.K.	
Sd'hol' Aoo'emo' /C.B.O.M. 01660170026 samai' ooboo' hoomo/NAME 'ASHISH' hanoor/ idnoak/DATE WT. - - - - - sd/- - - - - HTX-13-F0152 A.K.		Sd'hol' Aoo'emo' /C.B.O.M. 01660170026 samai' ooboo' hoomo/NAME 'ASHISH' hanoor/ idnoak/DATE WT. - - - - - sd/- - - - - HTX-13-F0152 A.K.	
Sd'hol' Aoo'emo' /C.B.O.M. 01660170026 samai' ooboo' hoomo/NAME 'ASHISH' hanoor/ idnoak/DATE WT. - - - - - sd/- - - - - HTX-13-F0152 A.K.		Sd'hol' Aoo'emo' /C.B.O.M. 01660170026 samai' ooboo' hoomo/NAME 'ASHISH' hanoor/ idnoak/DATE WT. - - - - - sd/- - - - - HTX-13-F0152 A.K.	
Sd'hol' Aoo'emo' /C.B.O.M. 01660170026 samai' ooboo' hoomo/NAME 'ASHISH' hanoor/ idnoak/DATE WT. - - - - - sd/- - - - - HTX-13-F0152 A.K.		Sd'hol' Aoo'emo' /C.B.O.M. 01660170026 samai' ooboo' hoomo/NAME 'ASHISH' hanoor/ idnoak/DATE WT. - - - - - sd/- - - - - HTX-13-F0152 A.K.	
Sd'hol' Aoo'emo' /C.B.O.M			