



Bharat Heavy Electricals Ltd.,
Electronics Division,
Mysore Road, Bangalore – 560 026

Tender Document for " Supply and E&C Support services for Modular Desks and Single Section Desks for TGENCO Manuguru (4X270MW) project (Ref. NKR0000054)

TENDER REFERENCE DOC	NKR0000054
TENDER DOCUMENT AVAILABLE FROM	30th NOVEMBER 2015
LAST DATE AND TIME FOR SUBMISSION OF TENDER	30TH DEC 2015 UPTO 13:00 PM
DATE AND TIME FOR TENDER OPENING	30TH DEC 2015 UPTO 13:30 PM
SUBMISSION OF TENDER	Bidder to submit tender in E-procurement site : https://bheleps.buyjunction.in/ . Refer instructions give in tender document for offer submission of bid in E-procurement site. Service provider: M-junction

This Tender Document Contains documents as per below index:

INDEX

SL No.	DESCRIPTION	PAGE No.
1	INDEX SHEET	01 TO 01
2	REQUEST FOR QUOTATION (RFQ) HEADER	02 TO 02
3	PQR CRITERIA	03 TO 03
4	SPECIFICATION	04 TO 17
5	PR DETAILS	18 TO 18
6	SPECIAL COMMERCIAL CONDITIONS OF CONTRACT (SCC)	19 TO 22
7	GENERAL COMMERCIAL CONDITIONS FOR CONTRACT WITH RELEVANT ANNEXURES. (GCC)	23 TO 29
8	INSTRUCTIONS TO BIDDERS (ITB)	30 TO 53

Contact Person at BHEL: NILMANI KUMAR , ENGINEER/PURCHASE(CE-MM-PR) Ph: 080-26998663

REQUEST FOR QUOTATION

	BHARAT HEAVY ELECTRICALS LIMITED Electronics Division PB No. 2606, Mysore Road Bangalore - 560026 INDIA	RFQ NUMBER: NKR0000054 RFQ DATE : 30.NOV.2015	Due Date 30.DEC.2015 Time: 13:00 HRS VENUE : NEW ENGG. BLDG
MMI:PU:RF:003			

PURCHASE FILE COPY	(for all correspondence) Purchase Executive : Nilmani Kumar Phone : 26998663 Fax : 00918026989227 E-mail: nilmanikumar@bheledn.co.in
-------------------------------	--

~~Please submit your lowest quotation subject to our terms and conditions attached for the material mentioned below. The quotation must be enclosed in a sealed envelope / Fax superscribed with RFQ no. and due date, should reach us on or before the due date by 13.00 hours IST and will be opened on the same day~~

SI No.	Description	Qty	Unit	Delivery qty	Delivery Date
1	PR0500005713 Single section desk for Manuguru Project As per Purchase Specification PS4042614 DRW PS4042614 00	128	ST	20 74 1 16 16 1	11.JAN.2016 11.JAN.2016 11.JAN.2016 11.JAN.2016 11.JAN.2016
2	PR0500005721 Desk for Manuguru Project (3 Sections) as per Purchase Specification PS4042614 DRW PS4042614 00	1	ST	1	11.JAN.2016
3	PR0500005730 Desk for Manuguru Project (4 Sections) as per Purchase Specification PS4042614 DRW PS4042614 00	3	ST	1 1 1	11.JAN.2016 11.JAN.2016 11.JAN.2016
4	PR0500005748 Desk for Manuguru Project (7 Sections) as per Purchase Specification PS4042614 DRW PS4042614 00	4	ST	1 1 1 1	11.JAN.2016 11.JAN.2016 11.JAN.2016 11.JAN.2016

Total Number of Items - 4

~~Please note that the tender will be opened in the presence of the bidders or his authorised representatives (maximum two per organisation) who choose to be present with authorisation letters. Refer annexure for the terms and conditions.
 Preference will be given to vendors who accepts our standard payment terms i.e.100% payment - 30 days after receipt of material at our works subject to acceptance.
 Please specify Terms of delivery, Excise duty, sales tax, Ex-BHEL, Ex-works surcharge, Insurance,P&F, Freight and other taxes very clearly .
 For evaluation,exchange rate(TT selling rate of SBI) as on scheduled date of tender opening (Part-I bid in case of two part bid) shall be considered.
 The offers of the bidders who are on the banned list as also the offer of the bidders, who engage the services of the banned firms, shall be rejected.The list of banned firms is available on BHEL web site www.bhel.com~~

- i). This is only RFQ not an order.
- ii). In all correspondence quote RFQ No. & due date.

For and On behalf of BHEL.

Page 1 OF 2

Pre-Qualification Requirements (PQR) of Bidders for Modular Desk, as a part of Offer:

1.0 The vendor shall be an Original Equipment Manufacturer (OEM) or their authorized dealers in India along with an authorization letter to be submitted. An authorized Representative/Dealer in India cannot quote for the same equipment from more than one OEM.

2.0 The offer shall be only for Modular type custom-made desk.

3.0 Offer shall be for new equipment and not for any refurbished / used equipment. All the parts used shall also be new and not used / refurbished. A declaration to the above effect to be furnished.

4.0 Foreign OEM shall have Authorized India dealer(s) / representative(s) for after sales service and support. The authorization letter for the dealer/representative shall be provided.

5.0 The vendor or their authorized service representatives shall have trained engineers in India for commissioning and service for the offered equipment and shall be in a position to provide prompt after sales services support for our installations.

6.0 The vendor shall be in a position to undertake AMC or provide service support for the equipment supplied, after the expiry of the warranty / guarantee period either directly or through a service representative.

7.0 The vendor shall have experience of supplying of Modular Control room Technical furniture for any major project (**Industry-Power/Process**) in last 5 years ending 31st March 2015 in India. The minimum any one of the order quantity criteria is as follows:

- a) **Three** similar completed supplies equivalent to 40% of this tender quantity (in this case, minimum 67 Nos. of Single Section Modular desk).
- b) **Two** similar completed supplies equivalent to 50% of this tender quantity (in this case, minimum 84 Nos. of Single Section Modular desk).
- c) **One** similar completed supplies equivalent to 80% of this tender quantity (in this case, minimum 134 Nos. of Single Section Modular desk).

Submit reference list of Projects wherein offered system is supplied & commissioned, along with details and Year of Commissioning of the system. Also copies of purchase order and dispatch documents should be mandatorily furnished for proof of the above

Vendors who are not registered in BHEL EDN for Modular desk system shall subsequently have to submit duly-filled Source Request Form (SRF), which shall be downloaded by Bidder from our website "www.bhel.com. SRF along with credentials to be furnished separately by the Bidder.

Before submission of offer for Technical/commercial clarification, please contact/discuss with BHEL-Engg(080-26998078)/MM(080-26998663) Department for clarification if required.

Important note :

1. **In case Bidder does not submit details mentioned in above clauses or meet the requirements of Pre-qualification requirements, Offers will be summarily rejected and Bidder's Technical offers/proposals will not be evaluated.**
2. **Vendor approval from customer will be required for qualifying the tender. For getting approval, Vendor to submit credentials along with Pre-qualification bid. If the customer does not approve the vendor within one month, the offer will not be considered.**



A4-10

PURCHASE SPECIFICATION

HMI Desks
Manuguru (4X270MW)

PS4042614

REV No. : 00

Page 1 of 14

COPYRIGHT AND CONFIDENTIAL
The information contained in this document is the property of BHARAT HEAVY ELECTRICALS LIMITED
This must not be used directly or indirectly, in any manner detrimental to the interest of the company

PROJECT : MANUGURU (4X270MW)

CUSTOMER : TSGENCO

EQUIPMENT : Operator Desk

TITLE
PURCHASE SPECIFICATION
HMI Desks
MANUGURU

Dept Code
404

DRN.

NAME

SIGN

DATE

PREPARED

ABHISHEK
RANJAN

26.10.2015

CHECKED

REETESH
KUMAR A

26.10.2015

APPROVED

A K SINHA

26.10.2015



A4-10

PURCHASE SPECIFICATION

HMI Desks
Manuguru (4X270MW)

PS4042614

REV No. : 00

Page 2 of 14

REVISION HISTORY SHEET

REV No.	DATE	NATURE OF CHANGE	REASON	PREPARED BY	CHECKED BY	REVIEWED BY
00	26.10.2015	FIRST ISSUE	---	AR	RKA	AKS

COPYRIGHT AND CONFIDENTIAL
The information contained in this document is the property of **BHARAT HEAVY ELECTRICALS LIMITED**
This must not be used directly or indirectly, in any manner detrimental to the interest of the company



A4-10

PURCHASE SPECIFICATION

HMI Desks
Manuguru (4X270MW)

PS4042614

REV No. : 00

Page 3 of 14

1. General:

The specification is for HMI Desks for Manuguru 4x270 MW project. The requirements are as below:

2. Technical specification: - Desk

A. Common to all Desks

SL.NO	Description	Yes/No	Supplier's Remark
1.	Operator desk should be closed type, modular & scalable in design		
2.	Operator desk shall consist of vertical, horizontal and base supports with their coverings for work surface, keyboard trays, mouse pads, monitor shelf and concealed cable and wire way management.		
3.	Profile structure of Desk shall be of 3 mm thick extruded aluminum/CRCA steel. Aluminium structure shall be anodized or powder coated paint finish		
4.	Work surface width and depth to be as per Drawing included as part of this specification. Table top shall be made of 30mm thick with the top 12mm of Acrylic solid surface and remaining 18mm of laminated MDF board.		
5.	Profiled extended support and cantilevered beam of Aluminum / steel to support legs to be provided which should have powder coated finish in approved color / shade.		
6.	Tray for housing keyboard and mouse in each section, complete with mounting arrangement to be provided.		
7.	The Desk can be designed, manufactured and supplied in separate shipping sections. Indicative drawings attached..		
8.	18mm MDF Openable front & back modesty with push locks, internal light, CPU sliding tray, cable basket, cable tray to be provided. Neoprene gaskets and hinges to be provided for the console doors.		
9.	CFL lamp shall be provided for internal illumination.		
10.	Adequate heat management provision for Exhaust of heat from within the Console Desk Assembly shall be provided. There will be multiple fans provided in the Control Desk, at least 2 Nos per section. Each Fan will be of 230 VAC 250 CFM Ball Bearing based. Ventilation louvers will be provided on both Front & Rear Modesty with special Air Filters.		
11.	Desks shall have concealed cable trays for wire dressing. Both Horizontal & Side Managers (2 separate horizontal cable routing wire baskets for power & data cables) shall be provided.		
12.	Each Section will be provided with 2 separate power distribution units (1 for Main line & 1 for UPS line). Each power distribution unit will have 6 points of 5/15 Amp sockets, Mains MCB On/Off Switch & Indicator		
13.	Foot rest to be provided for each section.		
14.	Refer sheet no. 13 of 14 for wiring scheme for each section. Terminal Blocks, MCBs, Spike Busters, Cables, fans, switches, CFL Socket and lamps and other items shown in		

COPYRIGHT AND CONFIDENTIAL
The information contained in this document is the property of BHARAT HEAVY ELECTRICALS LIMITED
This must not be used directly or indirectly, in any manner detrimental to the interest of the company



A4-10

PURCHASE SPECIFICATION

HMI Desks Manuguru (4X270MW)

PS4042614

REV No. : 00

Page 4 of 14

	the drawing and required to make connection and identification tags/Ferrules etc are in scope of supply of vendor		
15.	Earthing strip to be provided and all earthing points to be connected to the strip.		
16.	Double compression type cable gland to be provided.		
17.	25mm MDF board side panels (Fixed Side Panels) with glass to be provided and it shall be engraved/carved with the colored TGENCO emblem (soft copy of emblem shall be provided at time of manufacturing clearance).		

B: HMI Operator Desk CLOSED TYPE(7 sections) (Refer OGA of Operator Desk-sht 8 & 9)

SL.NO	Description	Yes/No	Supplier's Remark
1.	Operator Desk shall be closed type. The table top of the Operator desk shall be arc-shaped as per drawing for mounting monitors & keyboards of Operator Workstation (OWS).CPUs will be placed in the desk. Operator Desk will have 7 sections (for accommodating 14 CPUs, 14 keyboard, 14 mouse and 7 monitor as per Sht. No. 8 of 14).. Trays for accommodating two CPUs per section to be provided.		
2.	Tray for housing keyboard and mouse in each section, complete with mounting arrangement to be provided.		
3.	Mounting arrangement for 2 nos. of PA system and 2 nos. of telephone to be provided as per drawing. Suitable outlets with standard sockets shall be provided in the desk to connect telephone and PA system		

C: HMI Operator Desk CLOSED TYPE(4 sections) (Refer OGA of Operator Desk-sht 10)

SL.NO	Description	Yes/No	Supplier's Remark
1.	Operator Desk shall be closed type. The table top shape of the Operator desk shall be as per drawing for mounting monitors & keyboards of Operator Workstation (OWS).CPUs will be placed in the desk. Operator Desk will have 4 sections (for accommodating 8 CPUs, 8 keyboard, 8 mouse and 4 monitor as per Sht. No. 10 of 14). Trays for accommodating two CPUs per section to be provided.		
2.	Tray for housing keyboard and mouse in each section, complete with mounting arrangement to be provided.		
3.	Mounting arrangement for 2 nos. of PA system and 2 nos. of telephone to be provided as per drawing. Suitable outlets with standard sockets shall be provided in the desk to connect telephone and PA system		

D: HMI Operator Desk CLOSED TYPE(3 sections) (Refer OGA of Operator Desk-sht 11)

COPYRIGHT AND CONFIDENTIAL
 The information contained in this document is the property of BHARAT HEAVY ELECTRICALS LIMITED
 This must not be used directly or indirectly, in any manner detrimental to the interest of the company



A4-10

PURCHASE SPECIFICATION

HMI Desks Manuguru (4X270MW)

PS4042614

REV No. : 00

Page 5 of 14

SL.NO	Description	Yes/No	Supplier's Remark
1.	Operator Desk shall be closed type. The table top shape of the Operator desk shall be as per drawing, for mounting monitors & keyboards of Operator Workstation (OWS). CPUs will be placed in the desk. Operator Desk will have 3 sections (for accommodating 6 CPUs, 6 keyboard, 6 mouse and 3 monitor as per Sht. No. 11 of 14.). Trays for accommodating two CPUs per section to be provided.		
2.	Tray for housing keyboard and mouse in each section, complete with mounting arrangement to be provided.		
3	Suitable outlet with standard sockets shall be provided in the desk for connecting telephone		

E. HMI Operator Desk CLOSED TYPE(1 section) (Refer OGA of Operator Desk-sht 12)

SL.NO	Description	Yes/No	Supplier's Remark
1.	Operator Desk shall be closed type. The table top shape of the Operator desk shall be as per drawing for mounting monitors & keyboards of Operator Workstation (OWS). CPUs will be placed in the desk. Operator Desk will have 1 sections (for accommodating CPUs, keyboard, mouse and monitor as per Sht. No. 12 of 14.). Trays for accommodating CPU shall be provided.		
2.	Tray for housing keyboard and mouse complete with mounting arrangement to be provided.		
3	Suitable outlet with standard sockets shall be provided in the desk for connecting telephone		

NOTE:

- All items mentioned in specification and drawing is in vendor's scope**, except the following: (i) Monitor (ii) CPU (iii) Keyboard (iv) mouse (v) telephone (vi) PA system.
- The Monitor and CPU unit will weigh approximately 35-40 Kgs each and design submitted should be capable of supporting the above load. Approximate CPU dimensions 17.7 x 6.6 x 17.9 in (45.02 x 16.79 x 45.53 cm).
- Any minor change in design & accessory components due to end user requirements/comments during datasheet approval shall not have any price implication and will be within lump sum price.
- Color options for table top & side covers should be provided for review and selection by end user.
- Full details of BOM including make and model number as applicable should be provided.
- Details of materials used in the construction should be mentioned.
- While designing 7 section desks and 4 section desks. The Profile created by 2 no of 7 section desk and 1 no of 4 section desk shall be as per drawing shown in page no
- Desk shall arranged as per drawing without any sharp edges. Edges shall be extruded PVC or rounded post-formed laminate
- Back installed items shall be suitably concealed from front view

COPYRIGHT AND CONFIDENTIAL
 The information contained in this document is the property of BHARAT HEAVY ELECTRICALS LIMITED
 This must not be used directly or indirectly, in any manner detrimental to the interest of the company



A4-10

PURCHASE SPECIFICATION

HMI Desks
Manuguru (4X270MW)

PS4042614

REV No. : 00

Page 6 of 14

3. Technical specification: - Computer Chair [Refer page 14 for Drawing]

SL NO	Description	Yes/No	Suppliers Remark
1	Computer Chair to be provided as per drawing		
2	Items to be dismantled & packed for dispatch		
3	All nuts, screws, bolts & other accessories required for assembly at site along with 10% spare to be included in scope of supply		
4	Assembly at site is in vendor scope		

4. PAINTING

Finished surface to be free from waves, belies or other imperfections. Surface to be Powder Coated or if Spray painted, 2 coats of inhibitive epoxy primer surface to be applied. Paint with Minimum of 2 coats of Primer and 2 sprays of final finish colour to be applied OR powder coated with epoxy paint. Exact color and shade of components will be specified at the time of Order placement.

~~5. WARRANTY:~~

~~Offer to include "2 years warranty at site" against manufacturing defects from date of supply. Warranty to include all costs towards material, labour, to & fro travelling, accommodation and stay etc. Exact location of Project site will be intimated at time of PO placement.~~

6. DOCUMENTS REQUIRED WITH OFFER:

1. OGA and detailed dimensional Drawings to be submitted for approval before manufacture. Drawings to include dimensional sectional side view, top view, front and rear views, with plan of base frames (if applicable). Overall Width, Height, Depth and thickness of Supports / Legs also to be indicated.
2. Detail Bill of Material
3. Deviations from specifications (if any) along with justification on suitability of alternate offer. Offer liable for rejection if above documents are not submitted

7. DOCUMENTS TO BE SUBMITTED FOR MANUFACTURING CLEARANCE

After Placement of order, Vendor shall submit manufacturing document for obtaining manufacturing clearance. Following minimum documents are required for obtaining manufacturing clearance:

1. Detailed OGA of desk with front view, top view, rear view, sectional view, floor cut out details along with specification.
2. Electrical Wiring Diagram with BOM of all electrical items.
3. Quality Plan.
4. 3 D Color Images of desk.
5. Color Shade Options.

8. Document to be submitted for Dispatch Clearance/Pre-dispatch Inspection by BHEL/Customer at suppliers work:

Test Certificate (for dimensions, Visual inspection, Paint and Electrical items)



A4-10

PURCHASE SPECIFICATION

HMI Desks
Manuguru (4X270MW)

PS4042614

REV No. : 00

Page 7 of 14

9. Documents to be included with equipment

Packing List and Shipping section details for ease of identification of items at site.

10. GENERAL:

- All furniture to be directly dispatched to project site from Supplier's works after obtaining necessary Clearance from BHEL. Consignee details will be intimated at the time of PO placement.
- Item shall be packed in all-weather proof packing with sufficient cushioning to avoid transit damages. Specific storage requirements, if any, to be indicated by Supplier.
- **Assembly, erection and installation at site to be carried out by Supplier.**
- **Offer to include charges for same at site along with necessary touchup etc.**
- Quotation/Offer should clearly specify the address on which the purchase orders are to be placed.
- Name plate with following details are to be provided for each shipping section :

ITEM :

- PROJECT NAME / UNIT No. : As per PO
- CUSTOMER NAME : As per PO
- BHEL ORDER No. : As per PO
- Date of Dispatch to Site :
- For any doubts regarding furniture layouts, the drawings enclosed should be referred.

COPYRIGHT AND CONFIDENTIAL
The information contained in this document is the property of BHARAT HEAVY ELECTRICALS LIMITED
This must not be used directly or indirectly, in any manner detrimental to the interest of the company

OGA OF OPERATOR DESK (LAYOUT)

COMMON (UNIT-1 & 2)

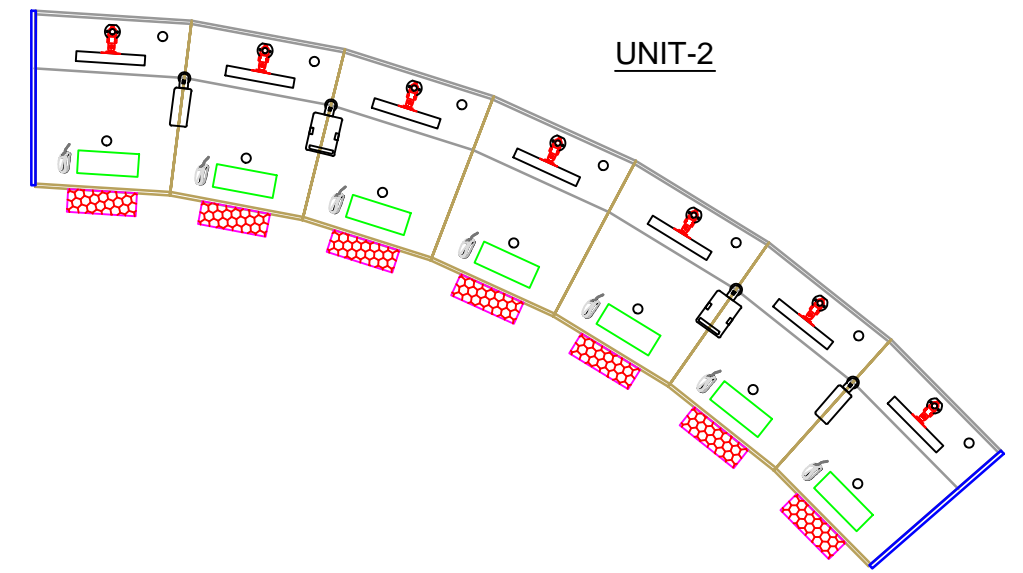
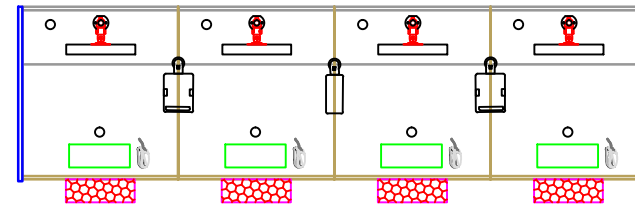
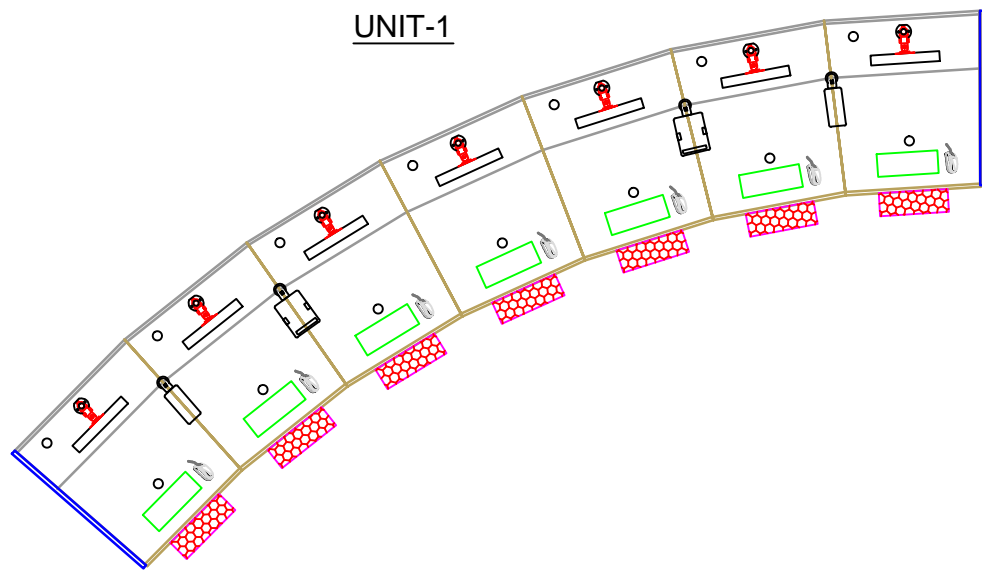

NOTE :
TYPICAL DRAWING IS MADE FOR UNIT-1 & UNIT-2, SAME WILL BE APPLICABLE FOR UNIT-3 & UNIT-4

OGA OF OPERATOR DESK (UNIT)

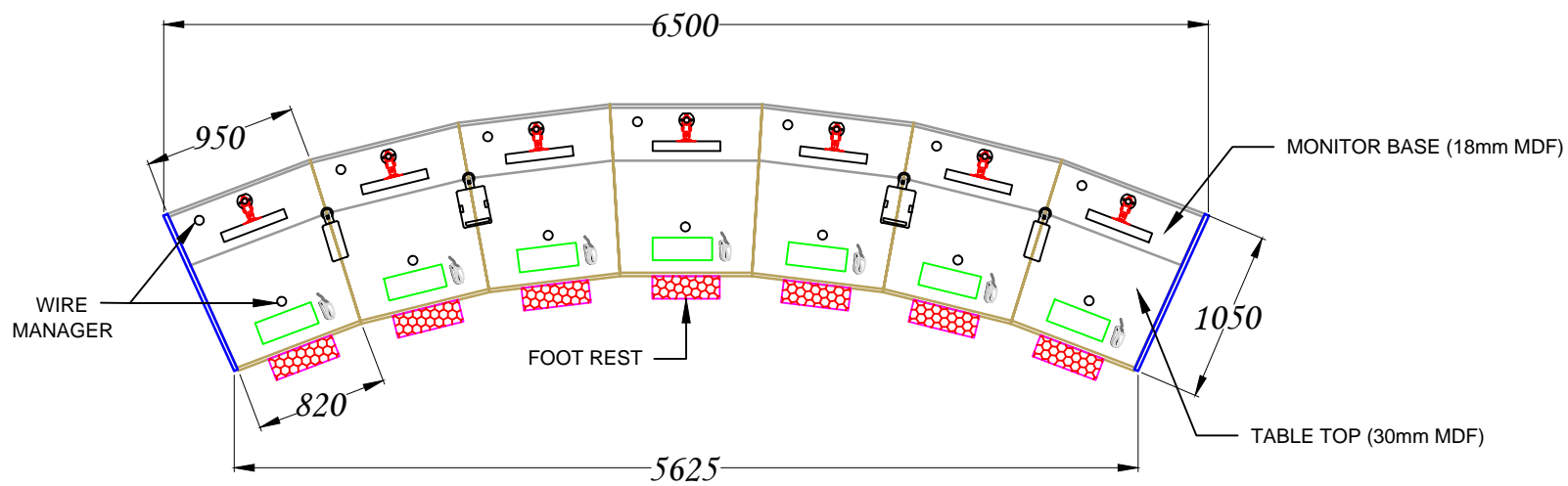

TOP VIEW

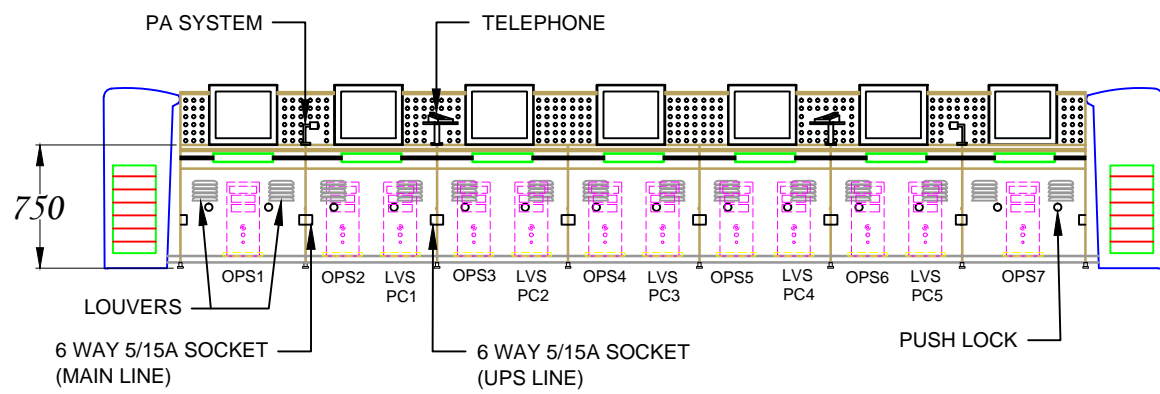

FRONT VIEW

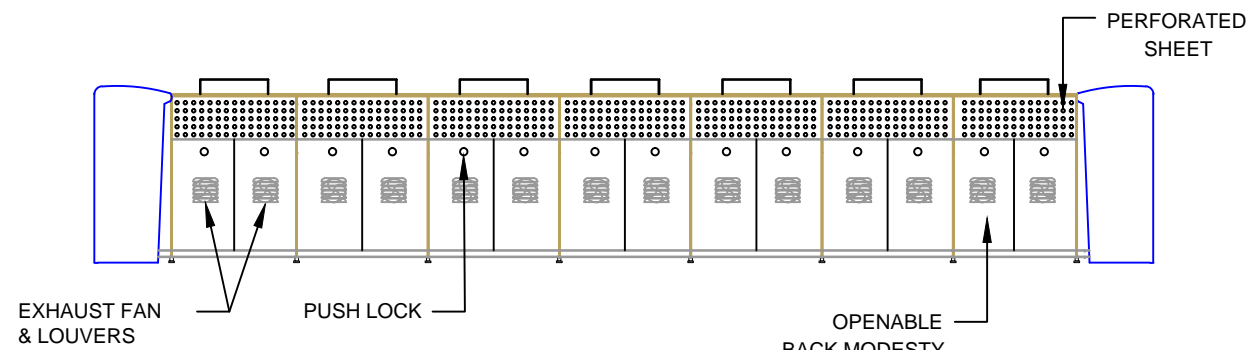

REAR VIEW

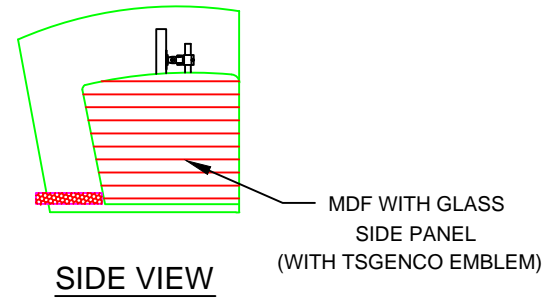

SIDE VIEW

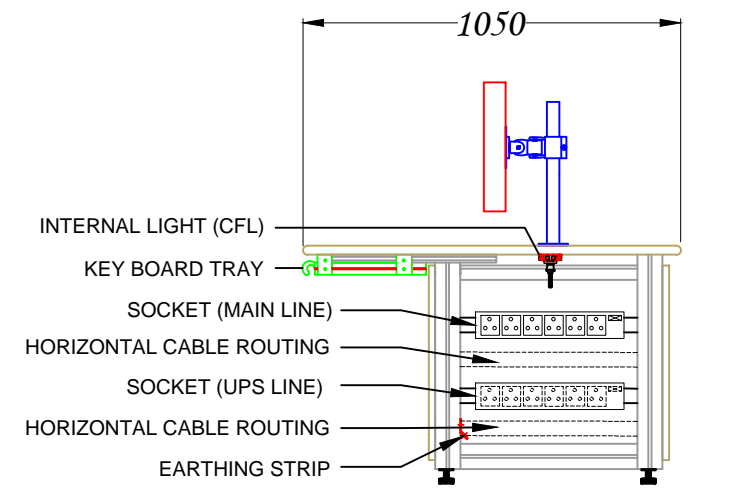

SECTIONAL SIDE VIEW

OPERATOR DESK WILL HAVE FOLLOWING FEATURES :

- 1) PROFILE STRUCTURE OF OPERATOR DESK WILL BE OF 3mm THICK EXTRUDED ALUMINUM / CRCA STEEL
- 2) TABLE TOP IS MADE OF 30mm THICK WITH THE TOP 12mm OF ACRYLIC SOLID SURFACE & REMAINING 18mm OF LAMINATED MDF BOARD
- 3) SEPARATE HORZ. CABLE ROUTING WIRE BASKETS FOR POWER & CABLES WILL BE PROVIDED
DOUBLE COMPRESSION TYPE CABLE GLAND WILL BE PROVIDED
- 4) POWER DISTRIBUTION SOCKETS (EACH USER STATIONS WILL BE PROVIDED WITH 2 No's
SEPARATE PDB UNITS (1 FOR MAIN & 1 FOR UPS LINE) EACH PDB UNIT WILL HAVE 6 POINTS
OF 5/15A SOCKETS
- 5) 25mm MDF BOARD SIDE PANELS (FIXED SIDE PANELS) WITH GLASS & IT SHALL BE GRAVED/CARVED
WITH THE COLOURED TSGENCO EMBLEM
- 6) 18mm MDF FRONT & BACK MODESTY PANEL (OPENABLE WITH PUSH LOCKS)
- 7) 2 Nos OF EXHAUST FAN WILL BE PROVIDED FOR ADEQUATE HEAT MANAGEMENT, FOR EACH SECTION
- 8) VENTILATION LOUVERS WILL BE PROVIDED ON BOTH FRONT & REAR MODESTY WITH AIR FILTERS.
- 9) MOUNTING ARRANGEMENT FOR 2 No's OF P.A SYSTEM & 2 No's OF TELEPHONE ARE SHOWN ON THE DESK
- 10) KEY BOARD TRAY WILL BE PROVIDED IN EACH SECTION
- 11) FOOT REST WILL BE PROVIDED FOR EACH SECTION
- 12) CPU WILL BE MOUNTED ON CPU SLIDING TRAY
- 13) NEOPRENE GASKETS SHALL BE PROVIDED FOR FRONT & BACK CONSOLE DOORS.
- 14) HINGES FOR THE DOORS SHALL BE PROVIDED
- 15) EARTHING STRIP WILL BE PROVIDED
- 16) CFL LAMP WILL BE PROVIDED FOR INTERNAL ILLUMINATION

OGA OF OPERATOR DESK (CHP)

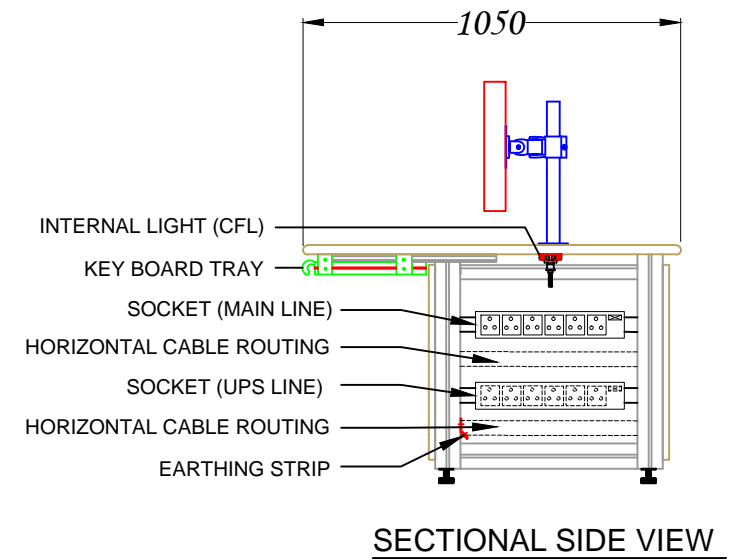
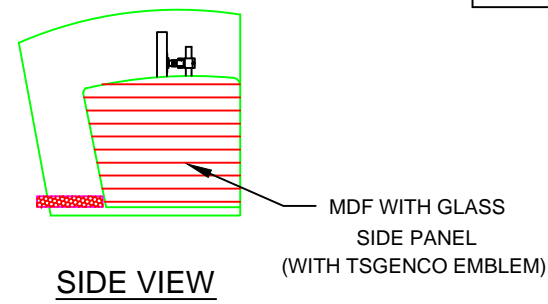
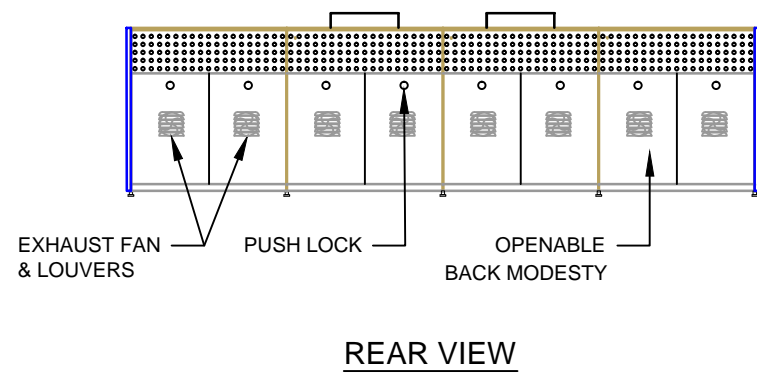
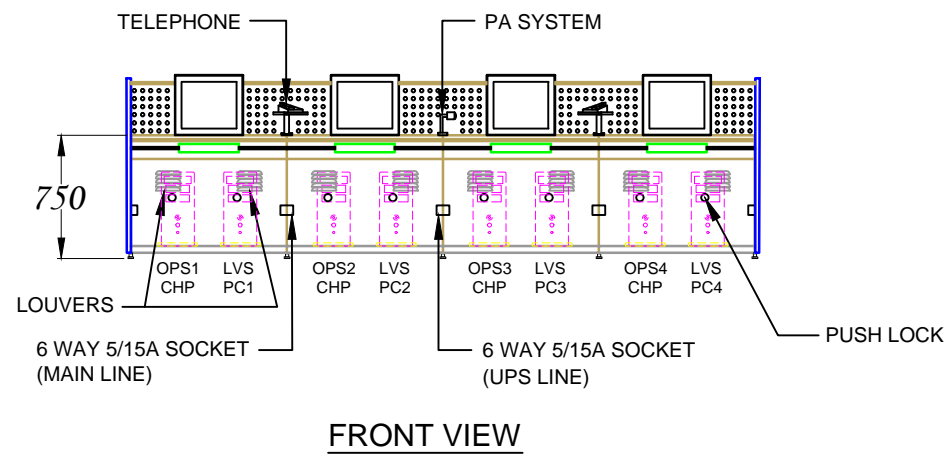
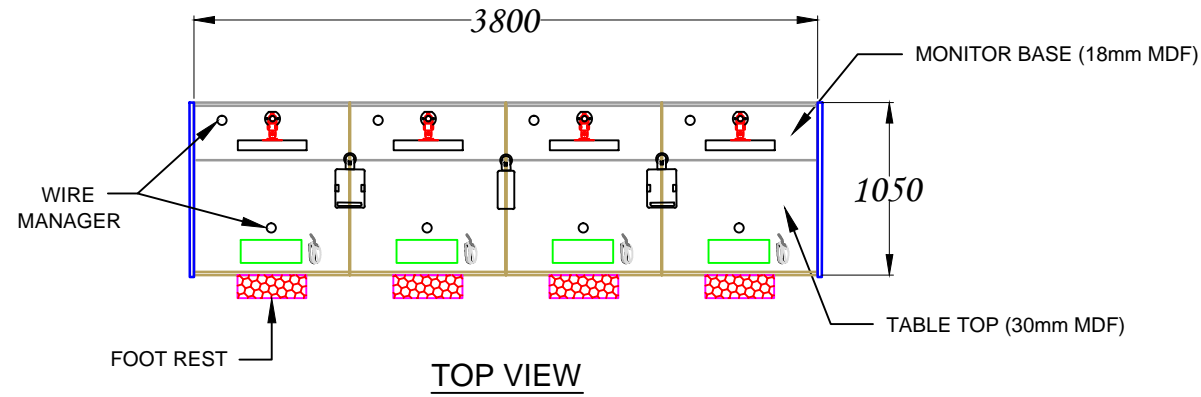

OPERATOR DESK WILL HAVE FOLLOWING FEATURES :

- 1) PROFILE STRUCTURE OF OPERATOR DESK WILL BE OF 3mm THICK EXTRUDED ALUMINUM / CRCA STEEL
- 2) TABLE TOP IS MADE OF 30mm THICK WITH THE TOP 12mm OF ACRYLIC SOLID SURFACE & REMAINING 18mm OF LAMINATED MDF BOARD
- 3) SEPARATE HORZ. CABLE ROUTING WIRE BASKETS FOR POWER & CABLES WILL BE PROVIDED DOUBLE COMPRESSION TYPE CABLE GLAND WILL BE PROVIDED
- 4) POWER DISTRIBUTION SOCKETS (EACH USER STATIONS WILL BE PROVIDED WITH 2 No's SEPARATE PDB UNITS (1 FOR MAIN & 1 FOR UPS LINE) EACH PDB UNIT WILL HAVE 6 POINTS OF 5/15A SOCKETS
- 5) 25mm MDF BOARD SIDE PANELS (FIXED SIDE PANELS) WITH GLASS & IT SHALL BE GRAVED/CARVED WITH THE COLOURED TSGENCO EMBLEM
- 6) 18mm MDF FRONT & BACK MODESTY PANEL (OPENABLE WITH PUSH LOCKS)
- 7) 2 Nos OF EXHAUST FAN WILL BE PROVIDED FOR ADEQUATE HEAT MANAGEMENT, FOR EACH SECTION
- 8) VENTILATION LOUVERS WILL BE PROVIDED ON BOTH FRONT & REAR MODESTY WITH AIR FILTERS.
- 9) MOUNTING ARRANGEMENT FOR 1 No OF P.A SYSTEM & 2 No's OF TELEPHONE ARE SHOWN ON THE DESK
- 10) KEY BOARD TRAY WILL BE PROVIDED IN EACH SECTION
- 11) FOOT REST WILL BE PROVIDED FOR EACH SECTION
- 12) CPU WILL BE MOUNTED ON CPU SLIDING TRAY
- 13) NEOPRENE GASKETS SHALL BE PROVIDED FOR FRONT & BACK CONSOLE DOORS.
- 14) HINGES FOR THE DOORS SHALL BE PROVIDED
- 15) EARTHING STRIP WILL BE PROVIDED
- 16) CFL LAMP WILL BE PROVIDED FOR INTERNAL ILLUMINATION

OGA OF OPERATOR DESK (AHP)

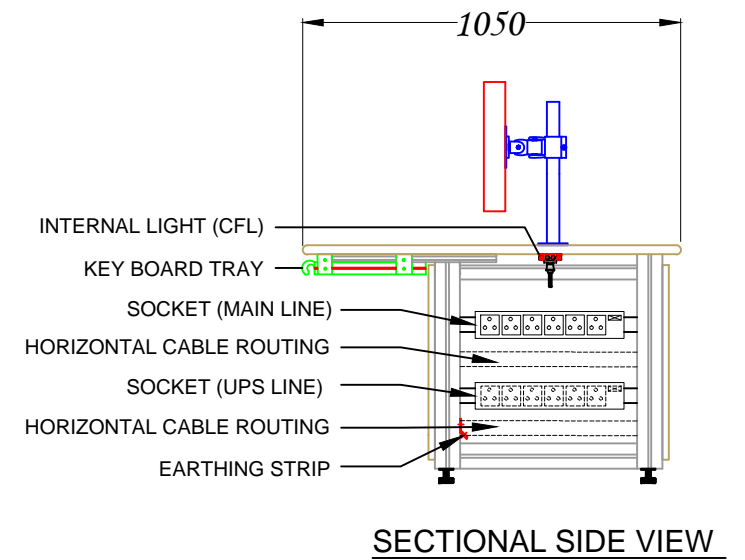
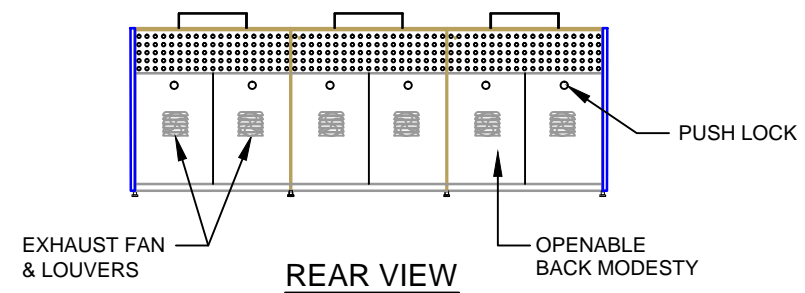
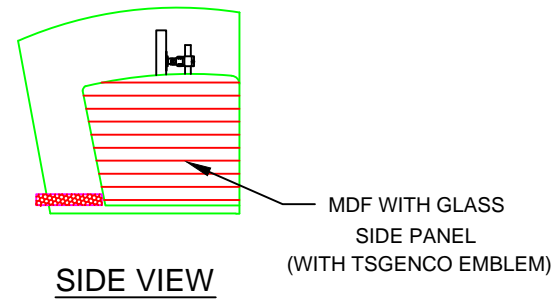
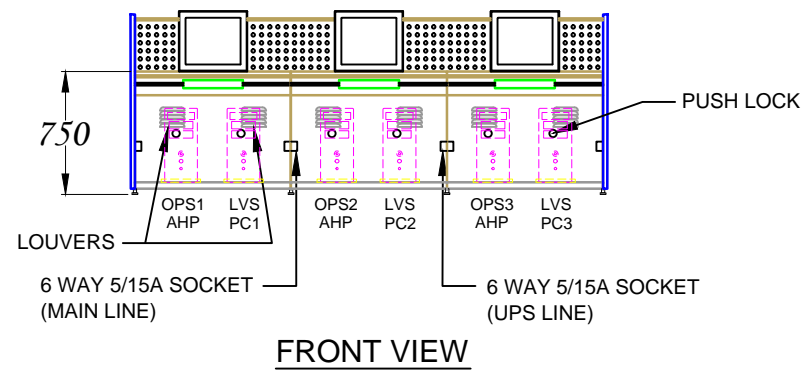
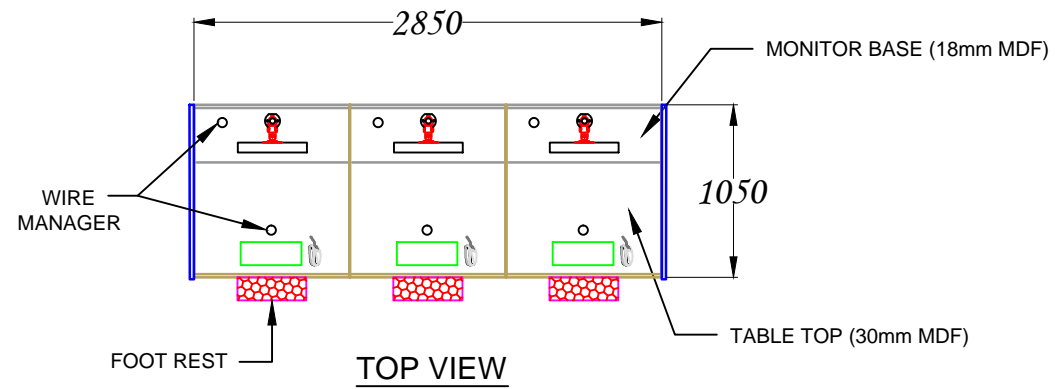

OPERATOR DESK WILL HAVE FOLLOWING FEATURES :

- 1) PROFILE STRUCTURE OF OPERATOR DESK WILL BE OF 3mm THICK EXTRUDED ALUMINUM / CRCA STEEL
- 2) TABLE TOP IS MADE OF 30mm THICK WITH THE TOP 12mm OF ACRYLIC SOLID SURFACE & REMAINING 18mm OF LAMINATED MDF BOARD
- 3) SEPARATE HORZ. CABLE ROUTING WIRE BASKETS FOR POWER & CABLES WILL BE PROVIDED DOUBLE COMPRESSION TYPE CABLE GLAND WILL BE PROVIDED
- 4) POWER DISTRIBUTION SOCKETS (EACH USER STATIONS WILL BE PROVIDED WITH 2 No's SEPARATE PDB UNITS (1 FOR MAIN & 1 FOR UPS LINE) EACH PDB UNIT WILL HAVE 6 POINTS OF 5/15A SOCKETS
- 5) 25mm MDF BOARD SIDE PANELS (FIXED SIDE PANELS) WITH GLASS & IT SHALL BE GRAVED/CARVED WITH THE COLOURED TSGENCO EMBLEM
- 6) 18mm MDF FRONT & BACK MODESTY PANEL (OPENABLE WITH PUSH LOCKS)
- 7) 2 Nos OF EXHAUST FAN WILL BE PROVIDED FOR ADEQUATE HEAT MANAGEMENT, FOR EACH SECTION
- 8) VENTILATION LOUVERS WILL BE PROVIDED ON BOTH FRONT & REAR MODESTY WITH AIR FILTERS.
- 9) KEY BOARD TRAY WILL BE PROVIDED IN EACH SECTION
- 10) FOOT REST WILL BE PROVIDED FOR EACH SECTION
- 11) CPU WILL BE MOUNTED ON CPU SLIDING TRAY
- 12) NEOPRENE GASKETS SHALL BE PROVIDED FOR FRONT & BACK CONSOLE DOORS.
- 13) HINGES FOR THE DOORS SHALL BE PROVIDED
- 14) EARTHING STRIP WILL BE PROVIDED
- 15) CFL LAMP WILL BE PROVIDED FOR INTERNAL ILLUMINATION

OGA OF COMPUTER TABLE

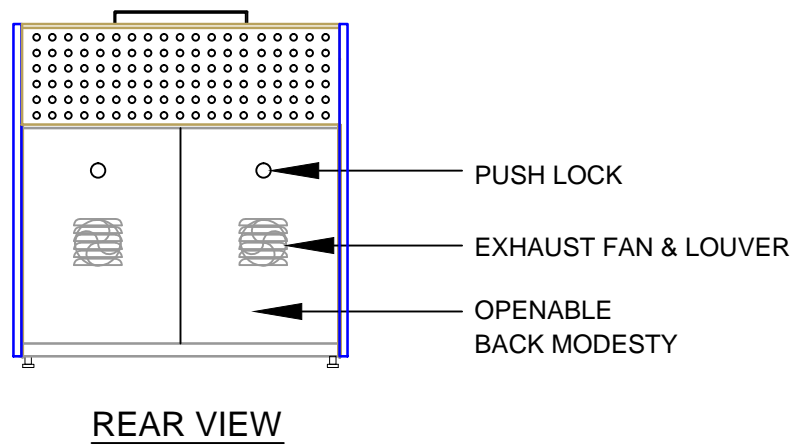
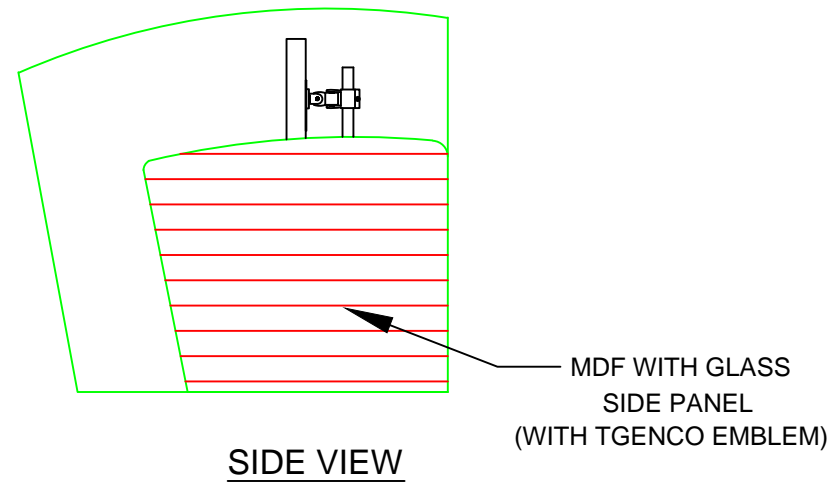
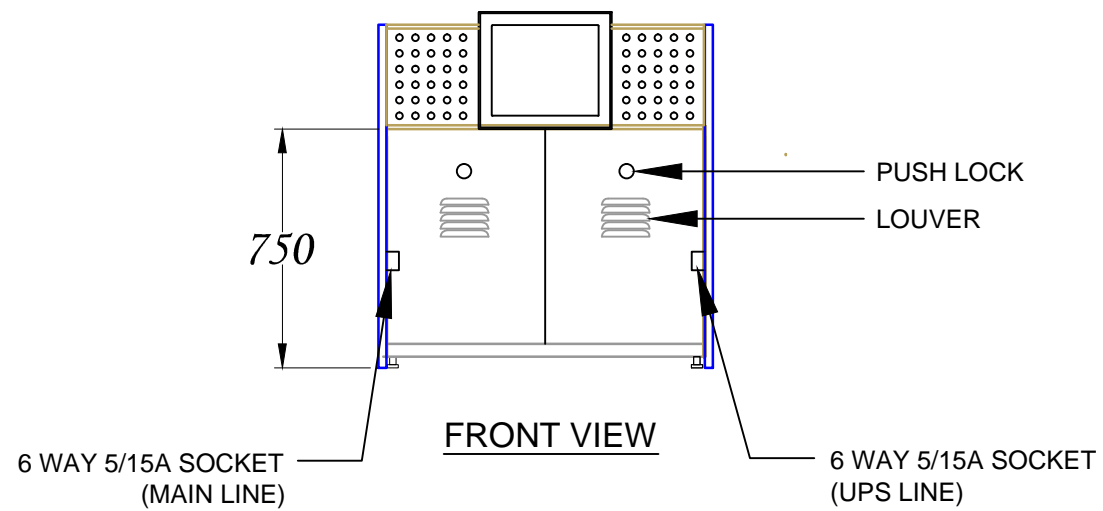
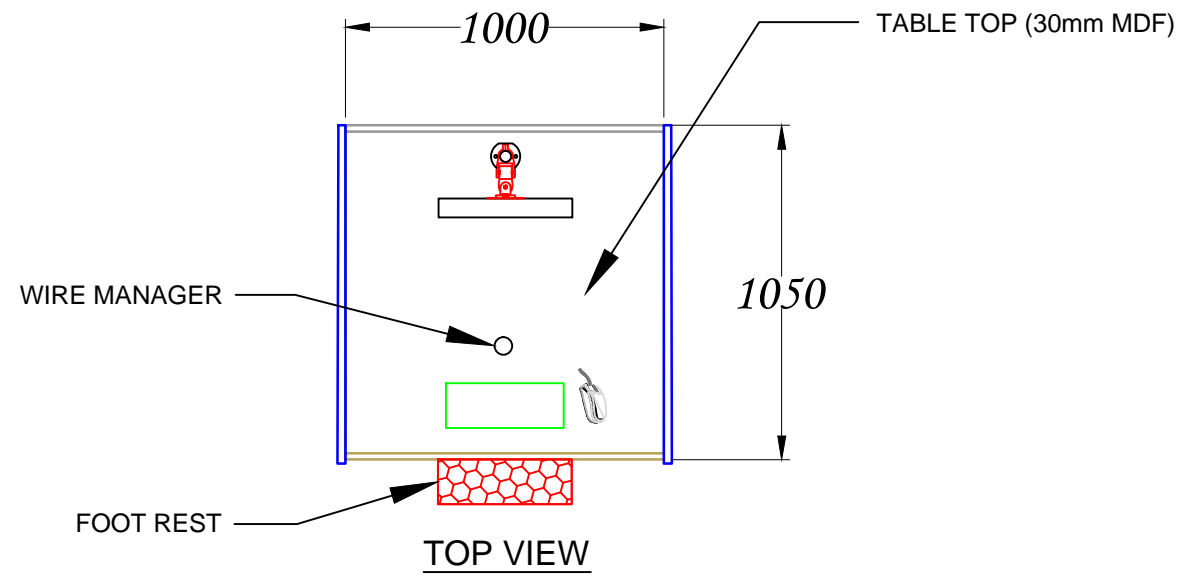

OPERATOR DESK WILL HAVE FOLLOWING FEATURES :

- 1) PROFILE STRUCTURE OF OPERATOR DESK WILL BE OF 3mm THICK EXTRUDED ALUMINUM / CRCA STEEL
- 2) TABLE TOP IS MADE OF 30mm THICK WITH THE TOP 12mm OF ACRYLIC SOLID SURFACE & REMAINING 18mm OF LAMINATED MDF BOARD
- 3) SEPARATE HORZ. CABLE ROUTING WIRE BASKETS FOR POWER & CABLES WILL BE PROVIDED DOUBLE COMPRESSION TYPE CABLE GLAND WILL BE PROVIDED
- 4) POWER DISTRIBUTION SOCKETS (EACH USER STATIONS WILL BE PROVIDED WITH 2 No's SEPARATE PDB UNITS (1 FOR MAIN & 1 FOR UPS LINE) EACH PDB UNIT WILL HAVE 6 POINTS OF 5/15A SOCKETS
- 5) 25mm MDF BOARD SIDE PANELS (FIXED SIDE PANELS) WITH GLASS & IT SHALL BE GRAVED/CARVED WITH THE COLOURED TSGENCO EMBLEM
- 6) 18mm MDF FRONT & BACK MODESTY PANEL (OPENABLE WITH PUSH LOCKS)
- 7) 2 Nos OF EXHAUST FAN WILL BE PROVIDED FOR ADEQUATE HEAT MANAGEMENT, FOR EACH SECTION
- 8) VENTILATION LOUVERS WILL BE PROVIDED ON BOTH FRONT & REAR MODESTY WITH AIR FILTERS.
- 9) CPU WILL BE MOUNTED ON CPU SLIDING TRAY
- 10) NEOPRENE GASKETS SHALL BE PROVIDED FOR FRONT & BACK CONSOLE DOORS.
- 11) HINGES FOR THE DOORS SHALL BE PROVIDED
- 12) EARTHING STRIP WILL BE PROVIDED
- 13) CFL LAMP WILL BE PROVIDED FOR INTERNAL ILLUMINATION

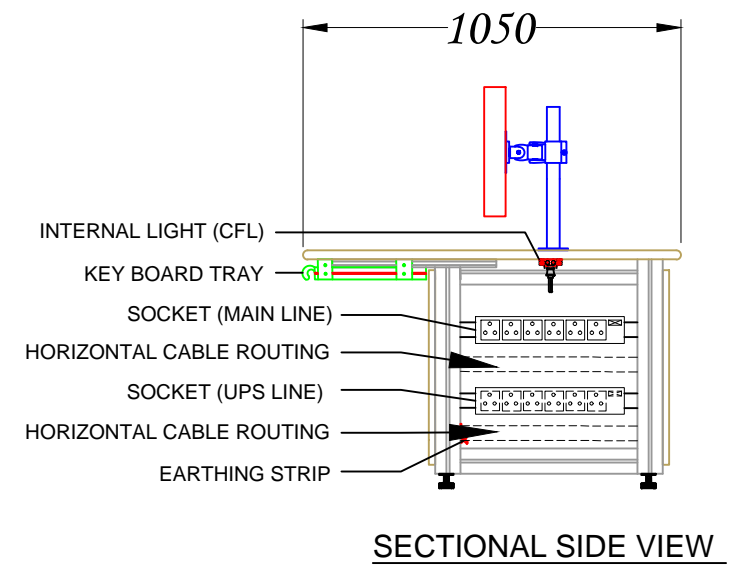

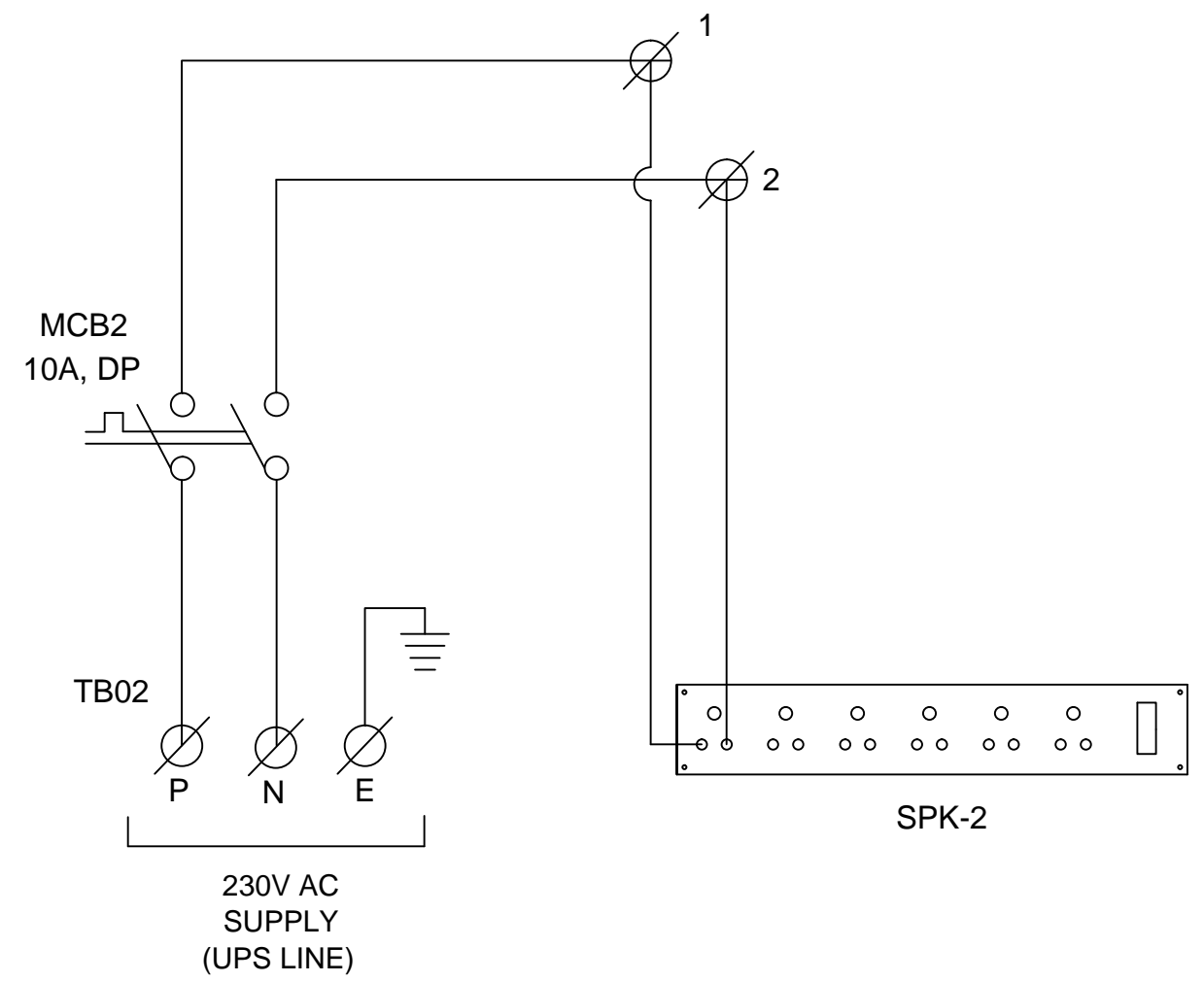
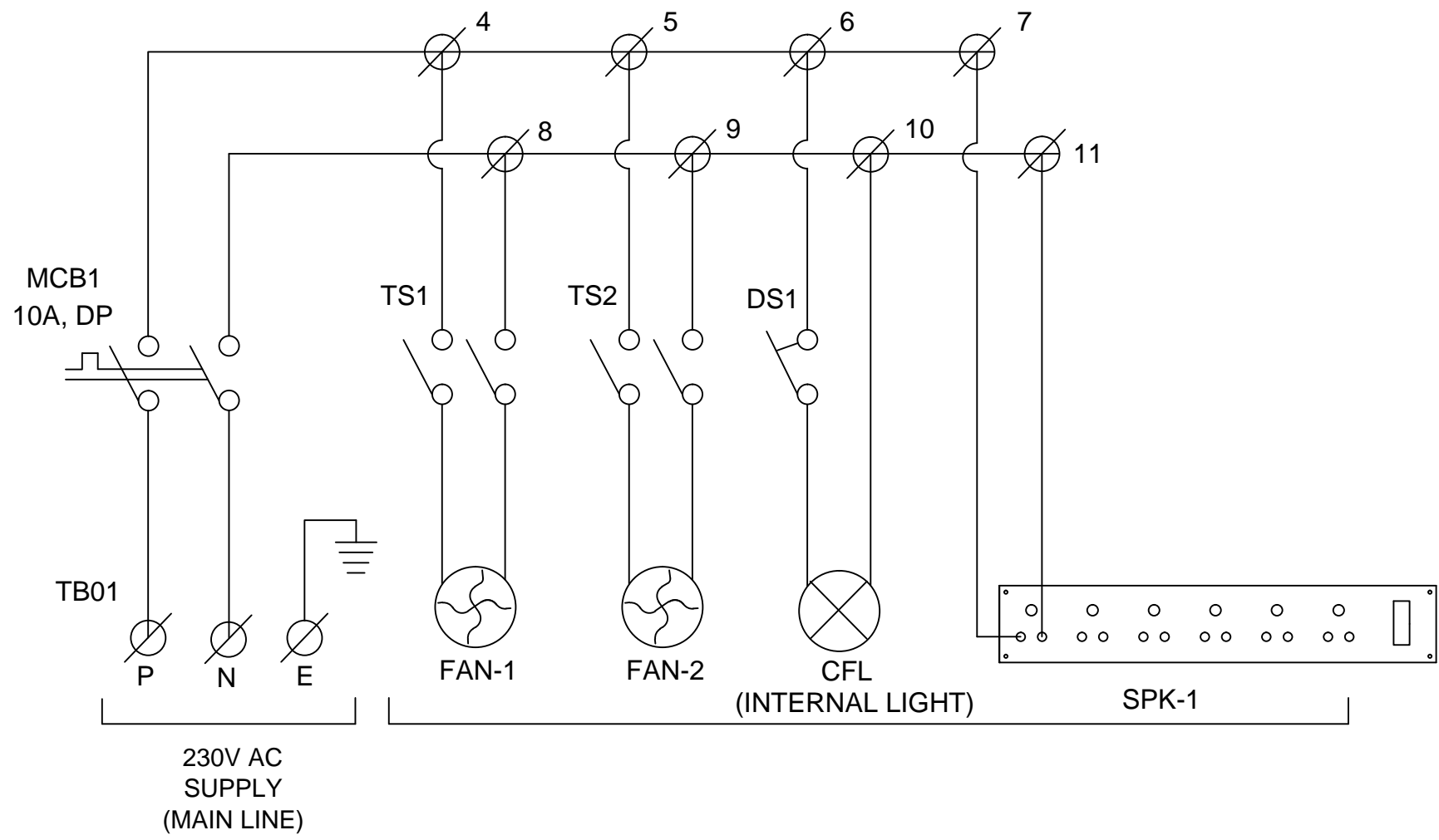

WIRING DRG. FOR EACH SECTION

NOTE :-

1. ALL TERMINAL WILL BE PHOENIX / ELEMEX MAKE.
2. ALL WIRING WILL BE DONE WITH PVC MULTISTRAND FLEXIBLE CU.
WIRE AS PER FOLLOWING SIZE & COLOUR CODE :
(a) 1.5 / 2.5 Sq. mm RED FOR PHASE
(b) 1.5 / 2.5 Sq. mm BLACK FOR NEUTRAL
(c) 1.5 / 2.5 Sq. mm GREEN FOR EARTHING
3. ALL TAGS WILL BE MADE OF METAPOLYSTER PRINTED STICKER.
4. 50% SPARE TBs OF EACH TYPE TO BE MOUNTED IN EACH SECTION
5. ALL SPIKE BUSTER EARTHING WILL BE LOOPED & IT WILL BE CONNECTED TO EARTHING STRIP OF DESK / TABLE

NOTE :-

- P : PHASE
- N : NEUTRAL
- E : EARTHING
- TB : TERMINAL BLOCK
- TS : TOGGLE SWITCH.
- MCB1 & 2 : 10A, 230V MINIATURE CIRCUIT BREAKER.
- DS1 : DOOR SWITCH
- CFL : CFL PANEL LIGHT
- SPK : SPIKE BUSTER
- FAN : 230VAC 250CFM BALL BEARING BASED EXHAUST FAN

COMPUTER CHAIR



FEATURES :

- Medium Back Chair
- PP Arms
- Chrome Base
- Chrome Plated Metal Frame
- Gas Lift
- Leatherite Tapestry
- Mechanism-Swivel Tilt

MODEL : GEEKEN GS-338 OR EQUIVALENT.

Annexure for Package wise qty for Modular desk for Manuguru project

SI No	Material	Qty	Package
1	Desk - 7section	1	Unit-1 Main Package
2	Desk - 4 section	1	Unit-1 Main Package
3	Single section Desk	74	Unit-1 Main Package
4	Desk 7 section	1	Unit-2 Main Package
5	Single section Desk	16	Unit-2 Main Package
6	Desk - 7section	1	Unit-3 Main Package
7	Desk - 4 section	1	Unit-3 Main Package
8	Single section Desk	20	Unit-3 Main Package
9	Desk 7 section	1	Unit-4 Main Package
10	Single section Desk	16	Unit-4 Main Package
11	Desk - 4 section	1	CHP
12	Single section Desk	1	CHP
13	Desk 3 section	1	AHP
14	Single section Desk	1	AHP



ಭಾರತ್ ಹೆವಿ ಎಲೆಕ್ಟ್ರಿಕಲ್ಸ್ ಲಿಮಿಟೆಡ್
भारत हेवी इलेक्ट्रिकल्स लिमिटेड
Bharat Heavy Electricals Ltd.,
(A Government of India undertaking)
Electronics Division
PB 2606 , Mysore Road Bangalore , 560026 INDIA

Page 1 of 4

CE: PR: 003- Rev 00

SPECIAL COMMERCIAL CONDITIONS OF CONTRACT

Reference is brought to BHEL's Instructions to Bidders (Document Ref: CE: PR: 001- Rev 00) and General Commercial Conditions for Contract (Document Ref: CE: PR: 002- Rev 00). These two documents along with Special Conditions of Contract annexed to this RFQ will form an integral part of the contract as and when the RFQ culminates into a Purchase Order / Contract.

RFQ No: NKR0000054

RFQ Date: 30.11.2015

Due Date: AS PER EPS

Project: TSGENCO Bhadradi TPS (4X270MW) Manuguru

Item Description: Modular Desk

Purchase Executives: In cases where tender documents are bulky, or due to some reasons tender documents are required to be submitted by hand, the offers are to be handed over to either of the following Purchase Officers: Mr.Nilmani Kumar, Engineer,CE-MM-PR_or Mr.H D CHANDRAIAH,Sr.Manager,CE-MM-PR

E-mail IDs: In case offers are sent through E-mail, please send the offers to both of the following email IDs: nilmanikumar@bheledn.co.in& ponnuguru@bheledn.co.in

E-tendering: **Applicable / Not Applicable**

Type of Bid: Three part Bid system

Reverse Auction: **Not Applicable** / Will be intimated during commercial clarifications to technically acceptable vendors. In case BHEL does not resort to Reverse Auction, the price bids and price impacts (if any) shall be opened as per BHEL's standard practice.

Splitting of tendered quantity to MSE vendors: The tendered quantity will /will not be split to MSE vendors subject to submission of relevant documents by vendors. **Refer clause H of Instructions to Bidders for conditions applicable and for information on documents to be submitted.**

Destination: Items are to be directly despatched to BHEL's Site Office or Stores/Customer's Stores located at/near **MANUGURU in TELANGANA STATE**. Road Permit, if applicable, will be issued by BHEL along with Despatch Clearance.

Project Benefits:

Indigenous scope of supply:

- Project is Mega Power Project or Ultra Mega Power Project: Eligible for "NIL" Excise Duty. Necessary documents for availing Excise Duty exemption by suppliers will be furnished by BHEL.
- Physical Export project: Eligible for complete exemption of Excise Duty & Sales Tax. Necessary documents for availing such benefits will be furnished by BHEL to suppliers.

• **Imported scope of supply:**

- Project is Mega Power Project or Ultra Mega Power Project: Eligible for "NIL" Customs Duty.
- Physical Export project: Eligible for complete exemption of Customs Duty.

Terms of Delivery:

Indicate station of despatch:

Indicate place of manufacturing (wherever applicable): _____

- **Indigenous scope of supply:** Ex-works (including Packing & Forwarding charges but excluding Taxes & Duties): _____
- **Imported scope of supply:** C.I.F-Bangalore (For Air Consignment)/C.I.F-Chennai (Including Packing, Forwarding, Handling, Ancillary charges like processing of Sight Draft/ Letter of Credit, negotiation of bank documents, Export declaration, Country of Origin etc): _____

S NO.	TERMS	BHEL ACCEPTABLE TERM	BIDDER'S CONFIRMATION	DEVIATION IF ANY
01	Validity	The offer will be valid for a period of 120 days from the date of technical bid opening.	AGREE	
02	Excise Duty & Cess	<p>If applicable, indicate current rate of Excise Duty and maximum rate of Excise Duty (against proof of Excise Invoice).</p> <p>However, for calculation purpose and arriving at "Total Cost to BHEL" maximum rate of Excise Duty will be considered. In case Excise Duty remains firm throughout the contract, the same shall be specifically indicated. Otherwise, maximum Excise Duty will be considered for arriving at lowest bidder.</p> <p>However, reimbursement of Excise Duty shall be at actuals against proof of Excise Invoice only. (Within contractual delivery).</p> <p>Physical export contract eligible for complete exemption of Excise duty against submission of necessary documents by BHEL like ARE-1/CT-1 form.</p>	<p>APPLICABLE / NOT APPLICABLE</p> <p>Present rate of Excise Duty with CESS%</p> <p>Maximum rate of Excise Duty with CESS%</p>	
03	Central Sales Tax (CST)	<p>If applicable, indicate current rate of sales tax against form "C".</p> <p>For issue of original form "C", vendor has to furnish "E1/E2" form. To enable vendor give E1/E2 form, photocopy of C form will be issued by BHEL.</p> <p>Please confirm submission of "E1/E2 Sale form".</p> <p>For physical export project, Sales Tax is exempted against necessary documents furnished by BHEL.</p>	<p>APPLICABLE / NOT APPLICABLE</p> <p>Present Sales Tax rate against form "C" %</p> <p>CONFIRMED</p>	
04	Value Added Tax (VAT)	<p>If applicable, indicate current rate of VAT.</p> <p>When VAT is applicable, BHEL ROD's/ Nodal Agency's Name, TIN No. and address to be indicated in invoice. (Note that two original invoice and one tax invoice should be submitted to BHEL).</p>	<p>APPLICABLE / NOT APPLICABLE</p> <p>VAT rate at present %</p> <p>NOTED</p>	
05	Octroi	If applicable, indicate current rate of octroi.	<p>AGREE</p> <p>Present Octroi rate%</p>	
06	Freight Charges (for indigenous scope of supply)	<p>Freight charges shall be to vendor's account.</p> <p>Quote lumpsum reasonable Freight charges separately in priced offer, plus service tax if any.</p> <p>Vendor's offer will be evaluated on "Total cost basis" including freight charges.</p> <p>Vendor shall book the consignment through their approved Road carriers on "Freight pre-paid" and door delivery consignee copy attached basis. Freight charges to be claimed from BHEL along with POD (Proof of Delivery) on original L/R.</p>	<p>AGREED</p> <p>and quoted as lumpsum amount in price bid.</p> <p>Service Tax ____% (extra /inclusive in freight charges)</p>	
07	Service Tax on E&C and Training Charges	<p>If applicable, indicate current rate of Service Tax _____%</p> <p>Service Tax Regn. No. _____</p> <p>Confirmation that Service Tax register is maintained.</p>	<p>APPLICABLE / NOT APPLICABLE</p> <p>CONFIRMED</p>	

08	Parting of license for imported raw materials	<p>In case of Mega project, Ultra-Mega project and Physical Export project where Custom Duty and Excise Duty are NIL and vendor is importing any raw materials / components for the enquired item, same are eligible for Zero Customs duty. As per EXIM policy, BHEL will part the import licence with the vendors to obtain import licence by themselves and custom clear the raw materials/ components by availing zero customs duty. Hence, please furnish list of raw materials / components to be imported by you with Quantity and CIF value (for which BHEL has to share import licence). The benefit due to the above shall be passed on to BHEL and confirmed in the quotation.</p> <p>If there are no imported raw materials/components, same shall be confirmed in the offer.</p>	<p>AGREE</p> <p>CIF value</p> <p>Yes, benefit passed-on to BHEL in the priced quotation.</p> <p>We confirm that there are no imported components.</p>	
09	Delivery Period	Within 07 weeks from the date of issue of approved documents or manufacturing clearance by BHEL, whichever is later.	<p>AGREE</p> <p>..... weeks</p>	
10	Guarantee/Warranty	36 months from the date of delivery of goods or 30 months from the date of commissioning of goods, whichever is earlier.	AGREE	
11	Inspection agency	<p>Materials will be inspected by :</p> <ul style="list-style-type: none"> • BHEL • Customer/Consultant/BHEL nominated Third Party Inspection Agency (TPIA) 	AGREE	
12	Terms of Payment at the time of material supply	<p>Refer Clause "F" of Instructions to Bidder for BHEL standard Payment terms and loading factors applicable for non-compliance against payment terms:</p> <hr/> <p>Indigenous Scope: a)Supply with E&C b)Supply with Supervision of E&C c) Supply only Imported Scope: d)Supply with E&C e)Supply with Supervision of E&C f) Supply only</p> <p>Note: Kindly indicate if High Sea Sales will be operated. If yes, confirm submission of relevant documents as per Annexure V.</p>	<p>AGREE</p> <p>YES / NO CONFIRMED</p>	
13	Performance Bank Guarantee (PBG)	<p>PBG will be applicable for a period of 24 months + claim period of 6 months for a value equal to 10% of the basic value of the purchase order.</p> <p>Refer Clause "G" of Instructions to Bidders.</p>	AGREE	
14	Terms of Payment not related to material supply	<p>For Training: 100% will be paid in 45 days from the date of completion of Training or 15 days from the date of submission of complete set of documentation, whichever is later. Separate invoice shall be submitted for Training charges along with documentary evidence.</p> <p>For Engineering & Documentation Charges: 100% will be paid in 45 days from the date of approval of final documents or 15 days from the date of submission of invoice, whichever is later. Separate invoice to be submitted for Engineering & documentation charges.</p>	AGREE	
15	Mode of despatch	<p>Indigenous Scope: By Road on Door Delivery Consignee Copy attached basis through your approved transporter (unless otherwise indicated in Despatch Instructions), only on receipt of Despatch Clearance from BHEL.</p>	AGREE	

		Imported Scope: By Air/Sea through BHEL approved Consolidator/Freight Forwarder, only on receipt of Despatch Clearance from BHEL.		
16	Despatch Documents	Complete set of despatch documents (original + 1 photocopy set) as per Purchase Order shall be forwarded to BHEL directly. Depending upon the project/customer demands, despatch documents may include one or more documents from the following: Commercial Invoice, Excise Invoice (if ED is applicable), Lorry Receipt (L/R), Packing List, Air Way Bill (AWB), Country of origin certificate, Warranty Certificate, Insurance Intimation letter, NIL Short Shipment Certificate, Original Performance Bank Guarantee (directly from issuing bank to BHEL), POD (Proof of Delivery) on original L/R, Disclaimer Certificate (as per BHEL format attached as Annexure XI) along with ER-1 form & attested excise invoice (as per project demands like Nuclear Power plant) etc. The precise list of despatch documents needed for a particular project will be specified in the Purchase Order. One set of Invoice, Packing List and L/R or AWB shall be e-mailed/faxed immediately to BHEL-EDN after despatch.	AGREE	
17	O & M Manuals	As built Drawings, O & M Manuals and other approved documents shall be furnished in required no. of sets as per Specification/Purchase Order. Note: Supply of above documents (O&M) in required no. of sets along with material shall be indicated in packing list. If not mentioned BHEL may insist for submission in required sets once again.	AGREE	
18	Quantity Tolerance	If applicable, indicate Quantity tolerance for each of the line item. For Impulse/seamless/ GI pipes one random length applicable for each variety of pipes.	CONFIRMED	Quantity Tolerance % Per Variety
19	Evaluation criteria for tendered item	Itemwise evaluation of tendered item. Splitting of tendered quantity to MSE vendors (if any) is applicable. OR Items will not be split on item wise lowest offer. All the items in the tender will be evaluated and procured as a SINGLE package i.e. ordering will be done on Single L1 vendor.	AGREE	
20	Integrity Commitment	Integrity commitment will be applicable in the tender process and execution of contracts as mentioned in clause "I" of Instructions to Bidders.	AGREE	

With this, it is inferred that vendor has understood and accepts all terms & conditions as indicated in Instructions to Bidders (Document Ref: CE: PR: 001- Rev 00) & General Commercial Conditions for Contract (Document Ref: CE: PR: 002- Rev 00).

VENDOR'S SIGNATURE WITH SEAL

NOTE: The above filled-in and signed-sealed document (in original) shall be furnished as part of Part-I Bid without fail. If no deviations are brought, it will be treated as if all terms and conditions of this enquiry are accepted by vendor without any deviation.



ಭಾರತ್ ಹೆವಿ ಎಲೆಕ್ಟ್ರಿಕಲ್ಸ್ ಲಿಮಿಟೆಡ್
 भारत हेवी इलेक्ट्रिकल्स लिमिटेड

Bharat Heavy Electricals Ltd.,
(A Government of India undertaking)
Electronics Division

PB 2606 , Mysore Road Bangalore , 560026 INDIA

CE: PR: 002- Rev 00

GENERAL COMMERCIAL CONDITIONS FOR CONTRACT

These 'General Commercial Conditions for Contract for Purchase' hereinafter referred to as GCC apply to all enquiries, tenders, requests for quotations, orders, contracts and agreements concerning the supply of goods and the rendering of related services (hereinafter referred to as "deliveries") to Bharat Heavy Electricals Limited and any of its units, regions or divisions (hereinafter referred to as "BHEL" or the Purchaser) or its projects / customers.

Any deviations from or additions to these GCC require BHEL's express written consent. The general terms of business or sale of the vendor shall not apply to BHEL. Acceptance, receipt of shipments or services or effecting payment shall not mean that the general terms of business or sale of the vendor have been accepted.

Orders, agreements and amendments thereto shall be binding if made or confirmed by BHEL in writing. Only the Purchasing department of BHEL is authorized to issue the Purchase Order or any amendment thereof.

Definitions: Throughout these conditions and in the specifications, the following terms shall have the meanings assigned to them, unless the subject matter or the context requires otherwise.

- 'The Purchaser' means Bharat Heavy Electricals Limited, Electronics division, Mysore road, Bangalore 560 026, a Unit of Bharat Heavy Electricals Limited (A Govt. of India Undertaking) incorporated under the Companies Act having its registered office at BHEL House, Siri Fort, New Delhi-110049, India and shall be deemed to include its successors and assigns. It may also be referred to as BHEL.
- 'The vendor' means the person, firm, company or organization on whom the Purchase Order is placed and shall be deemed to include the vendor's successors, representative heirs, executors and administrator as the case may be. It may also be referred to as Seller, Contractor or Supplier.
- 'Contract' shall mean and include the Purchase Order incorporating various agreements, viz. tender/ RFQ, offer, letter of intent / acceptance / award, the General Conditions of Contract and Special Conditions of Contract for Purchase, Specifications, Inspection / Quality Plan, Schedule of Prices and Quantities, Drawings, if any enclosed or to be provided by BHEL or his authorized nominee and the samples or patterns if any to be provided under the provisions of the contract.
- 'Parties to the Contract' shall mean the 'The Vendor' and the Purchaser as named in the main body of the Purchase Order.

Interpretation:

In the contract, except where the context requires otherwise:

- words indicating one gender include all genders;
- words indicating the singular also include the plural and words indicating the plural also include the singular;
- provisions including the word "agree", "agreed" or "agreement" require the agreement to be recorded in writing, and
- "Written" or "in writing" means hand-written, type-written, printed or electronically made, and resulting in a permanent record.

Applicable Conditions:

1. **Price Basis:** All prices shall be firm until the purchase order is executed / completed in all respects. No price variations / escalation shall be permitted unless otherwise such variations / escalations are provided for and agreed by BHEL in writing in the purchase order.
2. **Validity:** The offer will be valid for a period of 120 days from the date of technical bid opening date. Validity beyond 120 days, if required, will be specified in the SCC (special conditions of contract).
3. **Ordering and confirmation of Order:** Vendor shall send the order acceptance on their company letter head within two weeks from the date of Purchase Order or such other period as specified / agreed by BHEL. BHEL reserves the right to revoke the order placed if the order confirmation differs from the original order placed. The acceptance of goods/services/supplies by BHEL as well as payments made in this regard shall not imply acceptance of any deviations.
The purchase order will be deemed to have been accepted if no communication to the contrary is received within two weeks (or the time limit as specified / agreed by BHEL) from the date of the purchase order.
4. **Documentation:** After receipt of Purchase Order, vendor should submit required documents like drawings, bill of materials, datasheets, catalogues, quality plan, test procedure, type test report , O & M Manuals and/or any other relevant documents as per Specification/Purchase Order, as and when required by BHEL/Customer.
At any stage within the contract period, the vendor shall notify of any error, fault or other defect found in BHEL's documents /specifications or any other items for reference. If and to the extent that (taking account of cost and time) any vendor exercising due care would have discovered the error, fault or other defect when examining the documents/specifications before submitting the tender, the time for completion shall not be extended. However if errors, omissions, ambiguities, inconsistencies, inadequacies or other defects are found in the vendor's documents, they shall be corrected at his cost, notwithstanding any consent or approval.
5. **Penalty:**
For delay in documentation: In the event of delay in submission of complete set of documents ((like drawings, bill of materials, datasheets, catalogues, quality plan etc. as called in tender specifications including soft copies wherever applicable) in required sets beyond three weeks (or as agreed/indicated in the Purchase Order) from the date of Purchase Order, penalty at 0.5% (half percent) per week or part thereof, limited to a maximum of 5% (five percent) of the basic material value of the Purchase Order will be applicable.

For delay in delivery: In the event of delay in agreed contractual delivery as per Purchase Order, penalty @ 0.5 % (half percent) per week or part thereof but limited to a max of 10% (ten percent) value of undelivered portion (basic material cost) will be applicable. Delivery will commence from the date of document approval by customer / BHEL or date of issue of manufacturing clearance, whichever is later. The date for which Inspection call is issued by vendor along with test certificates / test reports / Certificate of Conformance / calibration reports, as proof of completion of manufacturing will be treated as date of deemed delivery for penalty calculation. In the absence of furnishing such document indicated above as proof of completion of manufacturing along with inspection call, actual date of inspection will be considered as date of deemed delivery and BHEL will not be responsible for delay in actual date of inspection.

Penalty for delayed documentation/delayed delivery, if applicable, shall be deducted at the time of first payment. If penalty is applicable for duration of less than a week, penalty @ 0.5% (half percent) of the basic material value will be deducted.
6. **Contract variations (Increase or decrease in the scope of supply):** BHEL may vary the contracted scope as per requirements at site. If vendor is of the opinion that the variation has an effect on the agreed price or delivery period, BHEL shall be informed of this immediately in writing along with technical details. Where unit rates are available in the Contract, the same shall be applied to such additional work. Vendor shall not

perform additional work before BHEL has issued written instructions / amendment to the Purchase Order to that effect. The work which the vendor should have or could have anticipated in terms of delivering the service(s) and functionality (i.e.) as described in this agreement, or which is considered to be the result of an attributable error on the vendor's part, shall not be considered additional work.

7. **Reverse Auction:** BHEL reserves the right to follow REVERSE AUCTION PROCEDURE (ONLINE BIDDING ON NETWORK) before finalising the Purchase order on technically competent bidders, as per the guidelines given in Annexure III. In case BHEL does not resort to Reverse Auction, the price bids and price impacts (if any) already submitted and available with BHEL shall be opened as per BHEL's standard practice.
8. **Inspection:** Prior written notice of at least 10 days shall be given along with internal test certificates / COC and applicable test certificates. Materials will be inspected by BHEL-EDN-QS/CQS or BHEL nominated Third Party Inspection Agency (TPIA) or BHEL authorized Inspection Agency or Customer / Consultant or jointly by BHEL & Customer / consultant. All tests have to be conducted as applicable in line with approved Quality plan or QA Checklist or Purchase specification and original reports shall be furnished to BHEL-EDN, Bangalore for verification / acceptance for issue of dispatch clearance.
All costs related to inspections & re-inspections shall be borne by vendor. Whether the Contract provides for tests on the premises of the vendor or any of his Sub-contractor/s, vendor shall be responsible to provide such assistance, labour, materials, electricity, fuels, stores, apparatus, instruments as may be required and as may be reasonably demanded to carry out such tests efficiently. Cost of any type test or such other special tests shall be borne by BHEL only if specifically agreed to in the purchase order.
9. **Transit Insurance:** Transit insurance coverage between vendor's works and project site shall be to the account of BHEL, unless specifically agreed otherwise. However, vendor shall send intimation directly to insurance agency (as mentioned in dispatch instructions issued by BHEL) through fax/courier/e-mail, immediately on dispatch of goods for covering insurance. A copy of such intimation sent by vendor to insurance agency shall be given to BHEL along with dispatch documents. Dispatch documents will be treated as incomplete without such intimation copy. BHEL shall not be responsible for sending intimations to insurance agency on behalf of the vendor.
10. **High Sea Sales (HSS):** Customs clearance of the consignment landed on Indian Sea / Air ports will be done by BHEL based on the original HSS documents provided by vendors.
Any delay in submission of complete / correct HSS documents to BHEL may incur demurrage charges. All demurrage charges on account of incomplete / incorrect HSS documents submission by vendor will be to vendor's account and all such charges will be recovered from any of the available vendor bills with BHEL.
11. **Packaging and dispatch:** The Seller shall package the goods safely and carefully and pack them suitably in all respects considering the peculiarity of the material for normal safe transport by Sea / Air / Rail / Road to its destination suitably protected against loss, damage, corrosion in transit and the effect of tropical salt laden atmosphere. The packages shall be provided with fixtures / hooks and sling marks as may be required for easy and safe handling. If any consignment needs special handling instruction, the same shall be clearly marked with standard symbols / instructions. Hazardous material should be notified as such and their packing, transportation and other protection must conform to relevant regulations.
The packing, shipping, storage and processing of the goods must comply with the prevailing legislation and regulations concerning safety, the environment and working conditions. Any Imported/Physical Exports items packed with raw / solid wood packing material should be treated as per ISPM – 15 (fumigation) and accompanied by Phytosanitary / Fumigation certificate. If safety information sheets (MSDS – Material Safety Data Sheet) exist for an item or the packaging, vendor must provide this information without fail along with the consignment.
Each package must be marked with Consignee name, Purchase order number, Package number, Gross weight and net weight, dimensions (L x B x H) and Seller's name. Packing list of goods inside each package with PO item number and quantity must also be fixed securely outside the box to indicate the contents of each box. Total number of packages in the consignment must also be indicated.
Separate packing & identification of items should be as follows.
 1. Main Scope - All items must be tagged with part no. & item description.
 2. Commissioning spares - All items must be tagged with part no. & item description.
 3. Mandatory spares - All items must be tagged with part no. & item description.

12. Assignment of Rights & Obligations; Subcontracting: Vendor is not permitted to subcontract the delivery or any part thereof to third party or to assign the rights and obligations resulting from this agreement in whole or in part to third parties without prior written permission from BHEL. Any permission or approval given by the BHEL shall, however, not absolve the vendor of the responsibility of his obligations under the Contract.
13. Progress report: Vendor shall render such report as to the progress of work and in such form as may be called for by the concerned purchase officer from time to time. The submission and acceptance of such reports shall not prejudice the rights of BHEL in any manner.
14. Non-disclosure and Information Obligations: Vendor shall provide with all necessary information pertaining to the goods as it could be of importance to BHEL. Vendor shall not reveal confidential information that may be divulged by BHEL to Vendor's employees not involved with the tender/ contract & its execution and delivery or to third parties, unless BHEL has agreed to this in writing beforehand. Vendor shall not be entitled to use the BHEL name in advertisements and other commercial publications without prior written permission from BHEL.
15. Cancellation / Termination of contract: BHEL shall have the right to completely or partially terminate the agreement by means of written notice to that effect. Termination of the Contract, for whatever reason, shall be without prejudice to the rights of the parties accrued under the Contract up to the time of termination.
BHEL shall have the right to cancel/foreclose the Order/ Contract, wholly or in part, in case it is constrained to do so, on account of any decline, diminution, curtailment or stoppage of the business.
16. Risk Purchase Clause: In case of failure of supplier, BHEL at its discretion may make purchase of the materials / services NOT supplied / rendered in time at the RISK & COST of the supplier. Under such situation, the supplier who fails to supply the goods in time shall be wholly liable to make good to BHEL any loss due to risk purchase.
In case of items demanding services at site like erection and commissioning, vendor should send his servicemen /representatives within 7 days from the service call. In case a vendor fails to attend to the service call, BHEL at its discretion may also make arrangements to attend such service by other parties at the **RISK & COST** of the supplier. Under such situation the supplier who fails to attend the service shall be wholly liable to make good to BHEL any loss due to risk purchase / service including additional handling charges due to the change.
17. Shortages: In the event of shortage on receipt of goods and/or on opening of packages at site, all such shortages shall be made good within a reasonable time that BHEL may allow from such intimation and free of cost. In case BHEL raises an insurance claim, the cost of material limited to insurance settled amount less handling charges will have to be reimbursed by the Supplier.
Transit Damages: In the event of receipt of goods in damaged condition or having found them so upon opening of packages at site, Supplier shall make good of all such damages within a reasonable time from such intimation by BHEL. In case BHEL raises an insurance claim, the cost of material limited to insurance settled amount less handling charges will be reimbursed.
18. Remedial work: Notwithstanding any previous test or certification, BHEL may instruct the vendor to remove and replace materials/goods or remove and re-execute works/services which are not in accordance with the purchase order. Similarly BHEL may ask the vendor to supply materials or to execute any services which are urgently required for any safety reasons, whether arising out of or because of an accident, unforeseeable event or otherwise. In such an event, Vendor shall provide such services within a reasonable time as specified by BHEL.
19. Indemnity Clause: Vendor shall comply with all applicable safety regulations and take care for the safety of all persons involved. Vendor is fully responsible for the safety of its personnel or that of his subcontractor's men / property, during execution of the Purchase Order and related services. All statutory payments including PF, ESI or other related charges have to be borne by the vendor. Vendor is fully responsible for ensuring that all legal compliances are followed in course of such employment.

20. Product Information, Drawings and Documents: Drawings, technical documents or other technical information received by Vendor from BHEL or vice versa shall not, without the consent of the other party, be used for any other purpose than that for which they were provided. They may not, without the consent of the Disclosing party, otherwise be used or copied, reproduced, transmitted or communicated to third parties. All information and data contained in general product documentation, whether in electronic or any other form, are binding only to the extent that they are by reference expressly included in the contract.

Vendor, as per agreed date/s but not later than the date of delivery, provide free of charge information and drawings which are necessary to permit and enable BHEL to erect, commission, operate and maintain the product. Such information and drawings shall be supplied in as many numbers of copies as may be agreed upon.

All intellectual properties, including designs, drawings and product information etc. exchanged during the formation and execution of the Contract shall continue to be the property of the disclosing party.

21. Intellectual Property Rights, Licenses: If any Patent, design, Trade mark or any other intellectual property rights apply to the delivery (goods / related service) or accompanying documentation shall be the exclusive property of the Vendor and BHEL shall be entitled to the legal use thereof free of charge by means of a non-exclusive, worldwide, perpetual license. All intellectual property rights that arise during the execution of the Purchase Order/ contract for delivery by vendor and/or by its employees or third parties involved by the vendor for performance of the agreement shall belong to BHEL. Vendor shall perform everything necessary to obtain or establish the above mentioned rights. The Vendor guarantees that the delivery does not infringe on any of the intellectual property rights of third parties. The Vendor shall do everything necessary to obtain or establish the alternate acceptable arrangement pending resolution of any (alleged) claims by third parties. The Vendor shall indemnify BHEL against any (alleged) claims by third parties in this regard and shall reimburse BHEL for any damages suffered as a result thereof.

22. Force Majeure: Notwithstanding anything contained in the purchase order or any other document relevant thereto, neither party shall be liable for any failure or delay in performance to the extent said failures or delays are caused by the "Act of God" and occurring without its fault or negligence, provided that, force majeure will apply only if the failure to perform could not be avoided by the exercise of due care and vendor doing everything reasonably possible to resume its performance.

A party affected by an event of force majeure which may include fire, tempest, floods, earthquake, riot, war, damage by aircraft etc., shall give the other party written notice, with full details as soon as possible and in any event not later than seven (7) calendar days of the occurrence of the cause relied upon. If force majeure applies, dates by which performance obligations are scheduled to be met will be extended for a period of time equal to the time lost due to any delay so caused.

Notwithstanding above provisions, in an event of Force Majeure, BHEL reserves for itself the right to cancel the order/ contract, wholly or partly, in order to meet the overall project schedule and make alternative arrangements for completion of deliveries and other schedules.

23. Guarantee / Warranty: Wherever required, and so provided in the specifications / Purchaser Order, the Seller shall guarantee that the stores supplied shall comply with the specifications laid down, for materials, workmanship and performance. Unless otherwise specified, guarantee / warranty period shall be 30 months after the date of delivery of goods or 24 months from the date of commissioning of goods whichever is earlier. The guarantee / warranty period as described above shall apply afresh to replaced, repaired or re-executed parts of a delivery. Unless otherwise specifically provided in the Purchase Order, Vendor's liability shall be co terminus with the expiration of the applicable guarantee / warranty period.
24. Limitation of Liability: Vendor's liability towards this contract is limited to a maximum of 100% of the contract value and consequential damages are excluded. However the limits of liability will have no effect in cases of criminal negligence or wilful misconduct.
- The total liability of Vendor for all claims arising out of or relating to the performance or breach of the Contract or use of any Products or Services or any order shall not exceed the total Contract price.

25. Liability during guarantee / warranty: Vendor shall arrange replacement / repair of all the defective materials / services under its obligation under the guarantee / warranty period. The rejected goods shall be taken away by vendor and replaced / repaired. In the event of the vendor's failure to comply, BHEL may take appropriate action including disposal of rejections and replenishment by any other sources at the cost and risk of the vendor.
In case, defects attributable to vendor are detected during first time commissioning or use, vendor shall be responsible for replacement / repair of the goods as required by BHEL at vendor's cost. In all such cases expiry of guarantee / warranty will not be applicable.
26. Liability after guarantee / warranty period: At the end of the guarantee / warranty, the Vendor's liability ceases except for latent defects (latent defects are defects / performance issues notices after the guarantee / warranty has expired). The Contractor's liability for latent defects warranty for the plant and equipment including spares shall be limited to a period of six months from the end of the guarantee / warranty period of the respective plant and equipment including spares or first time commissioning whichever is later but not later than 3 (three) years from the date of shipment.
27. Compliance with Laws: Vendor shall, in performing the contract, comply with all applicable laws. The vendor shall make all remittances, give all notices, pay all taxes, duties and fees, and obtain all permits, licences and approvals, as required by the laws in relation to the execution and completion of the contract and for remedying of any defects; and the Contractor shall indemnify and hold BHEL harmless against and from the consequences of any failure to do so.
28. Settlement of Disputes: Except as otherwise specifically provided in the Purchase Order, decision of BHEL shall be binding on the vendor with respect to all questions relating to the interpretation or meaning of the terms and conditions and instructions herein before mentioned and as to the completion of supplies/work/services, other questions, claim, right, matter or things whatsoever in any way arising out of or relating to the contract, instructions, orders or these conditions or otherwise concerning the supply or the execution or failure to execute the order, whether arising during the schedule of supply/work or after the completion or abandonment thereof. Any disputes or differences among the parties shall to the extent possible be settled amicably between the parties thereto, failing which the disputed issues shall be settled through arbitration. Vendor shall continue to perform the contract, pending settlement of dispute(s).
29. Arbitration Clause: In case amicable settlement is not reached in the event of any dispute or difference arising out of the execution of the Contract or the respective rights and liabilities of the parties or in relation to interpretation of any provision in any manner touching upon the Contract, such dispute or difference shall (except as to any matters, the decision of which is specifically provided for therein) be referred by either party to the sole arbitration of an Arbitrator appointed by the Executive Director/ General Manager of the purchasing unit/ region/ division of BHEL. Vendor shall have no objection even if the Arbitrator so appointed is an employee of BHEL or has ever dealt/ had to deal with any matter relating to this Contract.
Subject as aforesaid the provisions of the Arbitration and Conciliation Act, 1996 of India or any statutory modification or re-enactment thereof and the rules made there under and for the time being in force shall apply to the arbitration proceedings under this clause. It is a term of contract that the party initiating arbitration shall specify the dispute or disputes to be referred to arbitration under this clause together with the amount or amounts claimed in respect of each such dispute. The venue for the arbitration shall be Bangalore, India. The award of the arbitrator shall be a speaking award and shall be final, conclusive and binding on all parties to this contract.
The cost of arbitration shall be borne equally by the parties. Notwithstanding the existence of any dispute or difference or any reference for the arbitration, the vendor shall proceed with and continue without hindrance the performance of the work under the contract with due diligence and expedition in a professional manner.
30. Applicable Laws and Jurisdiction of Courts: Prevailing Indian laws both substantive and procedural, including modifications thereto, shall govern the Contract. Subject to the conditions as aforesaid, the competent courts in BANGALORE alone shall have jurisdiction to consider over any matters touching upon this contract.

31. General Terms: That any non-exercise, forbearance or omission of any of the powers conferred on BHEL and /or any of its authorities will not in any manner constitute waiver of the conditions hereto contained in these presents.

That the headings used in this agreement are for convenience of reference only.

That all notices etc., to be given under the Purchase order shall be in writing, type script or printed and if sent by registered post or by courier service to the address given in this document shall be deemed to have been served on the date when in the ordinary course, they would have been delivered to the addressee.

32. Fraud Prevention Policy: The bidder along with its associate/collaborators/sub-contractors/sub-vendors/consultants/service providers shall strictly adhere to BHEL Fraud Prevention Policy displayed on BHEL website <http://www.bhel.com> and shall immediately bring to the notice of BHEL Management about any fraud or suspected fraud as soon as it comes to your notice.



ಭಾರತ್ ಹವಿ ಎಲೆಕ್ಟ್ರಿಕಲ್ಸ್ ಲಿಮಿಟೆಡ್
 भारत हेवी इलेक्ट्रिकल्स लिमिटेड

Bharat Heavy Electricals Ltd.,
(A Government of India undertaking)
Electronics Division

PB 2606 , Mysore Road Bangalore , 560026 INDIA

CE: PR: 001- Rev 00

INSTRUCTIONS TO BIDDERS (Common for all RFQs)

Bidder is requested to read the instructions carefully and submit their quotation covering all the points:

A. GENERAL INSTRUCTIONS:

1. Any Purchase Order resulting from this enquiry shall be governed by the Instructions to Bidders (document reference: CE: PR: 001 – Rev 00), General Conditions of Contract (document reference: CE: PR: 002 - Rev 00) and Special Conditions of Contract, if any, of the enquiry.
2. Any deviations from or additions to the “General Conditions of Contract” or “Special Conditions of Contract” require BHEL’s express written consent. The general terms of business or sale of the bidder shall not apply to this tender.
3. Bidders (also includes the term suppliers / contractors wherever used in this document) are instructed to quote their most competitive price and best delivery, etc. in the offer. Prices should be indicated in both figures & words. **(Please also refer clause 11 under section B)**
4. Regret letter (either through post or by mail) indicating reasons for not quoting must be submitted without fail, in case of non-participation in this tender. If a bidder fails to respond against 3 consecutive tenders for the same item, he will be liable for removal as a registered vendor of BHEL.
5. Procurement directly from the manufacturers shall be preferred. However, if the OEM / Principal insist on engaging the services of an agent, such agent shall not be allowed to represent more than one manufacturer / supplier in the same tender. Moreover, either the agent could bid on behalf of the manufacturer / supplier or the manufacturer / supplier could bid directly but not both. In case bids are received from the manufacturer / supplier and his agent, bid received from the agent shall be ignored.
6. Consultant / firm (and any of its affiliates) shall not be eligible to participate in the tender/s for the related goods for the same project if they were engaged for consultancy services for the same project.
7. If an Indian representative / associate / liaison office quotes on behalf of a foreign based bidder, such representative shall furnish compulsorily the following documents:
 - a. Authorization letter to quote and negotiate on behalf of such foreign-based bidder.
 - b. Undertaking from such foreign based bidder that such contract will be honored and executed according to agreed scope of supply and commercial terms and conditions.
 - c. Undertaking shall be furnished by the Indian representative stating that the co-ordination and smooth execution of the contract and settlement of shortages / damages / replacement / repair of imported scope till system is commissioned and handed over to customer will be the sole responsibility of the Indian representative / associates / agent / liaison office.
 - d. Refer **Annexure X** on “Guidelines for Indian Agents”.
8. In case of imported scope of supply, customs clearance & customs duty payment will be to BHEL account after the consignment is received at Indian Airport / Seaport. Bidders must provide all original documents required for completing the customs clearance along with the shipment. Warehousing charges due to

incomplete or missing documentation will be recovered from the supplier's bill. All offers for imported scope of supply must be made from any of the gateway ports (within the country) indicated. **(Refer Annexure I)**

9. The offers of the bidders who are on the banned list and also the offers of the bidders, who engage the services of the banned firms, shall be rejected. The list of the banned firms is available on BHEL website: **www.bhel.com**
10. Business dealings with bidders will be suspended if they are found to have indulged in any malpractices / misconduct which are contrary to business ethics like bribery, corruption, fraud, pilferage, cartel formation, submission of fake/false/forged documents, certificates, information to BHEL or if they tamper with tendering procedure affecting the ordering process or fail to execute a contract, or rejection of 3 consecutive supplies or if their firms / works are under strike / lockout for a long period.

B. GUIDELINES FOR PREPARATION OF OFFER:

1. Quotation shall be submitted in Single Part Bid, Two Part Bid or Three Part Bid, as called for in the tender:
 - **SINGLE PART BID:** Technical and Commercial Bid with prices along with price summary & filled in BHEL Standard Commercial terms and conditions in a single sealed envelope.
 - **TWO PART BID:** Unpriced offer i.e. "Techno-commercial Bid" with filled in BHEL Standard Commercial terms and conditions in a sealed envelope **along with the copy of the "Price Bid" without the prices** should be enclosed in one cover and the cover must be super scribed "**Techno-commercial offer**" and Priced offer i.e. "Price Bid" containing price summary in a separate sealed envelope and must be super scribed "**Price Bid**". Both these envelopes shall be enclosed in a single sealed envelope super scribed with enquiry number due date of tender and any other details as called for in the tender document.
 - **THREE PART BID:** Pre-qualification Bid (Part-I), Techno Commercial Bid with filled in BHEL Standard Commercial terms and conditions (Part-II), and Price Bid (Part-III). All three envelopes shall be enclosed in a single sealed envelope super scribed with enquiry number due date of tender and any other details as called for in the tender document.

If any of the offers (Part I, Part II or Part III) are not submitted before the due date and time of submission or if any part of the offer is incomplete the entire offer of the bidder is liable for rejection.

2. Supplier shall ensure to super scribe each envelope with RFQ number, RFQ Date, RFQ Due date and time, Item Description and Project clearly & boldly. Also mention on the envelope whether it is "Techno Commercial Bid" or "Price Bid" or "Pre-Qualification Bid". Please ensure complete address, department name and purchase executive name is mentioned on the envelope (before dropping in the tender box or handing over) so that the tender is available in time for bid opening.
3. BHEL standard Commercial Terms and Conditions (duly filled, signed & stamped) must accompany Technical-Commercial offer without fail and should be submitted in original only. Xerox copy will not be accepted.
4. Any of the terms and conditions not acceptable to supplier, shall be explicitly mentioned in the Techno-Commercial Bid. If no deviations are brought out in the offer it will be treated as if all terms and conditions of this enquiry are accepted by the supplier without deviation.
5. Deviation to this specification / item description, if any, shall be brought out clearly indicating "DEVIATION TO BHEL SPECIFICATION" without fail, as a part of Techno-Commercial Bid. If no deviations are brought out in the offer it will be treated as if the entire specification of this enquiry is accepted without deviation.
6. Suppliers shall submit one set of original catalogue, datasheets, bill of materials, dimensional drawings, mounting details and / or any other relevant documents called in purchase specification as part of Technical Bid.
7. "Price Bid" shall be complete in all respects containing price break-up of all components along with all

applicable taxes and duties, packing & forwarding charges (if applicable), freight charges (if applicable) etc. Once submitted no modification / addition / deletion will be allowed in the "Price Bid." Bidders are advised to thoroughly check the unit price, total price to avoid any discrepancy.

8. In addition, bidder shall also quote for erection & commissioning charges (E&C charges), documentation charges, service charges, testing Charges (type & routine), training charges, service tax, etc. wherever applicable. The price summary must indicate all the elements clearly.
9. Vendors should indicate "lump sum" charges (including To & Fro Fare, Boarding, Lodging, Local Conveyance etc.) for Supervision of Erection, Commissioning and handing over to customer. The quotation shall clearly indicate scope of work, likely duration of commissioning, pre-commissioning checklist and service tax (if any).
10. Wherever bidders require PAC (Project Authority Certificate) for import of raw materials, components required for Mega Power Projects, Export Projects or other similar projects wherein supplies are eligible for customs duty benefits, lists and quantities of such items and their values (CIF) has to be mentioned in the offer. Prices must be quoted taking into account of such benefits.
11. All quotations shall be free from corrections /overwriting. Corrections if any should be authenticated with signature and seal. Any typographical error, totaling mistakes, currency mistake, multiplication mistake, summing mistakes etc. observed in the price bids will be evaluated as per **Annexure II** "Guidelines for dealing with Discrepancy in Words & Figures – quoted in price bid". BHEL decision will be final.

C. GUIDELINES FOR OFFER SUBMISSION:

1. Offers / Quotations must be dropped in tender box before 13.00 Hrs. on or before due date mentioned in RFQ. The offers are to be dropped in the proper slot of the Tender Box kept in our reception area with caption "CE, SC&PV, DEFENCE." Tenders are opened on 3 days in a week (Monday/Wednesday/Friday). Tender must be deposited in the slot corresponding to the day (Monday - Box no.4/Wednesday - Box no. 6 /Friday - Box no.8) while depositing the offer. **(This clause will not be applicable for e-tenders)**
2. E-Mail / Internet / EDI offers received in time shall be considered only when such offers are complete in all respects. In case of offers received through E-mail, please send the offer to the email ID specified in the SCC of the tender. (Refer to SCC document of tender)
3. In cases where tender documents are bulky, or due to some reasons tender documents are required to be submitted by hand or through posts/couriers, the offers are to be handed over either of the two officers whose names are mentioned in the RFQ. (Refer to SCC document of tender)
4. Tenders will be opened on due date, time and venue as indicated in the RFQ in the presence of bidders at the venue indicated in the RFQ. In case of e-procurement, bidders can see tender results till seven days after due date and time.
5. Vendor will be solely responsible:
 - a. For submission of offers before due date and time. Offers submitted after due date and time will be treated as "Late offers" and will be rejected.
 - b. For submission of offers in the correct compartment of the tender box based on the day of due date (Monday/Wednesday/Friday). Please check before dropping your offer in the correct tender box.
 - c. For depositing offers in proper sealed condition in the tender box. If the bidder drops the tender in the wrong tender box or if the tender document is handed over to the wrong person BHEL will not be responsible for any such delays.
 - d. For offers received through email etc., suppliers are fully responsible for lack of secrecy on information and ensuring timely receipt of such offers in the tender box before due date & time.
 - e. In case of e-tender, all required documents should be uploaded before due date and time. Availability of power, internet connections, etc. will be the sole responsibility of the vendor. Wherever assistance is

needed for submission of e-tenders, help line numbers and executives of service provider of BHEL may be contacted.

Service provider: M-junction

Website address: <https://bheleps.buyjunction.in/>

Helpline no.: 033-66106426/6217/6013/6046/6176 (9:30 am to 5:30 pm)

9163348283/9163348284/9163348285/9163348286/8584008116 (5:30 pm to 8:30 pm)

Purchase Executive / BHEL will not be responsible for any of the activities relating to submission of offer.

D. PROCESSING OFFERS RECEIVED:

1. Any discount / revised offer submitted by the supplier on its own shall be accepted provided it is received on or before the due date and time of offer submission (i.e. Part-I bid). The discount shall be applied on pro-rata basis to all items unless specified otherwise by the bidder.
2. Changes in offers or Revised offers given after Part-I bid opening shall not be considered as a part of the original offer unless such changes / revisions are requested by BHEL.
3. In case there is no change in the technical scope and / or specifications and / or commercial terms & conditions, the supplier will not be allowed to change any of their bids after Technical bids are opened (after the due date and time of tender opening).
4. In case of changes in scope and/ or technical specifications and/ or commercial terms & conditions by BHEL and it accounts for price implications from vendors, all techno-commercially acceptable bidders shall be asked by BHEL (after freezing the scope, technical specifications and commercial terms & conditions) to submit the impact of such changes on their price bid. Impact price will be applicable only for changes in technical specification / commercial conditions by BHEL. The impact price must be submitted on or before the cut-off date specified by BHEL and the original price bid and the price impact bid will be opened together at the time of price bid opening.
5. BHEL EDN reserves the right to adopt Reverse Auction or standard Price Bid Opening procedure for price evaluation, at its discretion. This will be decided after completion of technical evaluation of tender. **(Refer Annexure III for Guidelines for Reverse Auction).**
6. Un-opened bids (including price bids) will be returned to the respective bidders after release of PO and receipt of order acknowledgement from the successful bidder.
7. After receipt of Purchase Order, supplier should submit required documents like drawings, bill of materials, datasheets, catalogues, quality plan, test procedure, type test report , O & M Manuals and / or any other relevant documents as per Specification / Purchase Order, as and when required by BHEL / Customer.
8. Any deviation to the terms and conditions not mentioned in the quotation by supplier in response to this enquiry will not be considered, if put forth subsequently or after issue of Purchase Order, unless clarification is sought for by BHEL EDN and agreed upon in the Purchase Order.
9. Evaluation shall be on the basis of delivered cost (i.e. "Total Cost to BHEL").
"Total Cost to BHEL" shall include total basic cost, packing & forwarding charges, taxes and duties, freight charges, insurance, service tax for services, any other cost indicated by vendor for execution of the contract and loading factors (for non-compliance to BHEL Standard Commercial Terms & Conditions). Benefits arising out of Nil Import Duty on Mega Projects, Physical Imports or such 100% exemptions (statutory benefits), customer reimbursements of statutory duties (like Excise Duty, CST, VAT) will also be taken into account at the time of tender evaluation. (wherever applicable and as indicated in SCC document of tender)

10. For evaluation of offers in foreign currency, the exchange rate (TT selling rate of SBI) shall be taken as under:

Single part bids: Date of tender opening

Two/three part bids: Date of Part-I bid opening

Reverse Auction: Date of Part-I bid opening

In case of Performance Bank Guarantee (PBG) also, exchange rate will be considered as mentioned above for converting foreign currency to Indian currency and vice versa.

If the relevant day happens to be a bank holiday, then the exchange rate as on the previous working day of the bank (SBI) shall be taken.

11. Ranking (L-1, L-2 etc.) shall be done only for the techno-commercially acceptable offers.

E. INFORMATION ON PAYMENT TERMS:

1. All payments will be through Electronic Fund transfer (EFT). Vendor has to furnish necessary details as per BHEL standard format (**Refer Annexure IV**) for receiving all payments through NEFT. (Applicable for Indian vendors only)
2. In case of High Sea Sales transaction, customs clearance of the consignment landed on Indian Sea / Air ports will be done by BHEL based on the original HSS documents provided by vendors. All warehousing charges due to delay in submission of complete and or correct HSS documents to BHEL will be to suppliers account only. Such recovery will be made out of any of the available bills. (**Refer Annexure V**).
3. Statutory deductions, if any, will be made and the deduction certificate shall be issued. In case vendor does not provide PAN details, the TDS deduction shall be at the maximum percentage stipulated as per the provisions of Income Tax Act. (Applicable for Indian vendors only).
Foreign vendors shall submit relevant details of their bankers like Swift Code, Banker's Name & Address etc.
4. Vendors must submit bills & invoices along with required supporting documents in time. Incomplete documentation / delayed submission of invoice / documents will result in corresponding delay in payment.

F. STANDARD PAYMENT TERMS OF BHEL-EDN

Purchase Orders for indigenous procurement

(a) SUPPLY WITH E&C:

- 1) 85% of basic value (excluding E&C charges) + 100% of taxes, duties and freight charges will be paid in 45 days from the date of dispatch or 15 days from the date of submission of complete set of documentation whichever is later.
- 2) 15% of basic value (retention money), (excluding E&C charges) will be paid in 15 days from the date of submission of documents against supplementary invoice with proof of completion of E&C along with E & C charges (if any)

(b) SUPPLY WITH SUPERVISION OF E&C:

- 1) 90% basic value (excluding E&C charges) + 100% of taxes, duties and freight charges will be paid in 45 days from the date of dispatch or 15 days from the date of submission of complete set of documentation whichever is later.
- 2) 10% of basic value (retention money), (excluding E&C charges) will be paid in 15 days from the date of completion of erection and commissioning against supplementary invoice with proof of completion of E&C along with supervision charges (if any)

(c) SUPPLY ONLY:

- 1) 100% of PO value with taxes, duties and freight will be paid in 45 days from the date of dispatch or 15 days from the date of submission of complete set of documentation whichever is later.

Purchase orders for import procurement:**(d) SUPPLY WITH E&C:**

- 1) 85% of the basic value (excluding E&C charges) will be paid in 45 days, against usance draft of 45 days, from the date of AWB/BOL on submission of complete set of documents.
- 2) 15% of basic value (retention money), (excluding E&C charges) will be paid in 15 days from the date of completion of E&C along with E & C charges against supplementary invoice with proof of completion of E&C (if any).

(e) SUPPLY WITH SUPERVISION OF E&C:

- 1) 90% of the value of the order will be paid on the 45th day, against usance draft of 45 days, from the date of AWB/BOL on submission of complete set of documents.
- 2) 10% of basic value (retention money) will be paid in 15 days from the date of completion of erection and commissioning against supplementary invoice with proof of completion of E&C along with supervision charges (if any).

(f) SUPPLY ONLY:

- 1) 100% of PO value will be paid against usance draft of 45 days from the date of dispatch or 15 days from the date of submission of complete set of documents whichever is later.

LOADING FACTORS FOR PAYMENT TERMS:

- 1) For offers received with requests for negotiation of documents through bank loading will be 15% of basic value (all bank charges to be borne by the seller).
(This loading factor is applicable only for purchase orders for indigenous supply).
- 2) In all cases where credit period is 30 days but not in line with the above mentioned standard payment terms offered loading applicable will be 5% of basic value.
(This loading factor is applicable only for purchase orders for indigenous supply).
- 3) For offers received with Letter of Credit payment term in place of sight draft payment term, loading applicable will be 5% of basic value. Additional loading of 5% will be applicable for payment terms as Letter of Credit with usance of less than 45 days.
(This loading factor is applicable only for purchase orders for imported supply).
- 4) For offers received with Sight Draft payment terms with usance of less than 45 days, loading of 5% will be applicable.
(This loading factor is applicable only for purchase orders for imported supply).
- 5) All payment terms with credit period of less than 30 days for indigenous supply and any other variation of payment terms are liable for rejection.
- 6) Standard payment terms indicated in para F (a), (b), (c), (d), (e) and (f) will not attract any loading.

Note 1: Basic value of Purchase Order mentioned above will include all components of the purchase order and will exclude only taxes, duties, freight and E&C charges (wherever applicable).

Wherever the Purchase Order is split into import portion and indigenous portion of supply the retention money will be 15% or 10% (as applicable) of both purchase order values put together.

Note 2: *If the E&C could not be completed till the end of the Warranty period due to reasons not attributable to the supplier, BHEL may consider releasing the retention money to the supplier against Bank Guarantee for equivalent value valid for an initial period of one year.*

G. Bank guarantee (BG) / Performance bank guarantee (PBG):

1. Bank guarantee (BG) / Performance bank guarantee (PBG) will be applicable as called in the tender documents. Such PBG shall be valid for a period of 36 months + claim period of 6 months for a value equal to 10 % of the basic value of the purchase order. No deviation for the duration of PBG / BG will be permitted.
 - a. PBG shall be from any of the BHEL consortium of bankers (**refer Annexure VI**).
 - b. PBGs from nationalized banks are also acceptable.
 - c. PBG should be sent directly by the bank to the dealing executive mentioned in the purchase order located at the address mentioned in the purchase order. PBG should be in the format indicated. (**Refer annexures VII & VIII respectively**). No deviation to these formats will be allowed.
 - d. Confirmation from any of the BHEL consortium of banks or any of the Indian Public Sector Banks is essential for the acceptance of PBGs issued by foreign banks (located outside India).
 - e. Expired BGs / PBGs will be returned only after expiry of the claim period or on completion of the contractual obligation.
 - f. **Non acceptance for submission of PBG will attract loading as indicated below**
 - i. Loading will be equal to the percentage of value for which BG / PBG is not provided. (Ex: if PBG / BG is given for 3 % of the basic value against 10% specified, loading applicable will be 7% (10 – 3 = 7 %). This value will be added to the quoted price while evaluating the lowest offer.

H. PROVISIONS APPLICABLE FOR MSE VENDORS (MICRO AND SMALL ENTERPRISES)

Vendors who qualify as MSE vendors are requested to submit applicable certificates (as specified by the Ministry of Micro, Small and Medium Enterprises) at the time of vendor registration. Vendors have to submit any of the following documents along with the tender documents in the Part I / Technical bid cover to avail the applicable benefits.

- a. Valid NSIC certificate or
- b. Entrepreneur's Memorandum part II (EM II) certificate (deemed valid for 2 years).
- c. EM II certificate with CA certificate (**in the prescribed format given in Annexure IX**) applicable for the year certifying that the investment in plant and machinery of the vendor is within permissible limits as per the MSME Act 2006 for relevant status where the deemed validity is over.
- d. Documents submitted for establishing the credentials of MSE vendors must be valid as on the date of part I / technical bid opening for the vendors to be eligible for the benefits applicable for MSE vendors. Documents submitted after the Part I / Technical bid opening date will not be considered for this tender.

PURCHASE PREFERENCE FOR MSE VENDORS:

- e. MSE vendors quoting within a price band of L1 + 15% shall be allowed to supply up to 20% of the requirement against this tender provided
 1. The MSE vendor matches the L1 price
 2. L1 price is from a non MSE vendor
 3. L1 price will be offered to the nearest vendor nearest to L1 in terms of price ranking (L2 - nearest to L1). In case of non-acceptance by the MSE vendor (L2) next ranking MSE vendor will be offered who is within the L1 + 15% band (if L3 is also within 15% band).
 4. 20% of the 20% (i.e. 4% of the total enquired quantity) will be earmarked for SC/ST owned MSE firms provided conditions as mentioned in (1) and (2) are fulfilled.

5. In case no vendor under SC / ST category firms are meeting the conditions mentioned in (1) and (2) or have not participated in the tender, in such cases the 4% quantity will be distributed among the other eligible MSE vendors who have participated in the tender.
6. Serial no. 1 to 5 will not be applicable wherever it is not possible to split the tendered quantity / items on account of customer contract requirement, or the items tendered are systems. Such information that tendered quantity will not be split will be indicated in the SCC.

I. INTEGRITY COMMITMENT IN THE TENDER PROCESS, AND EXECUTION OF CONTRACTS:

1. Commitment by BHEL:

BHEL commits to take all measures necessary to prevent corruption in connection with the Tender process and execution of the Contract. BHEL will, during the tender process, treat all bidder / suppliers in a transparent and fair manner, and with equity.

2. Commitment by Bidder(s)/ Contractor(s):

- a. The Bidder(s)/ Contractor(s) commit(s) to take all measures to prevent corruption and will not directly or indirectly try to influence any decision or benefit which he is not legally entitled to.
- b. The Bidder(s)/ Contractor(s) will not enter with other Bidder(s) into any undisclosed agreement or understanding or any actions to restrict competition.
- c. The Bidder(s)/ Contractor(s) will not commit any offence under the relevant Acts. The Bidder(s)/ Contractor(s) will not use improperly, for purposes of competition or personal gain or pass on to others, any information or document provided by BHEL as part of business relationship.
- d. The Bidder(s)/ Contractor(s) will, when presenting his bid, disclose any and all payments he has made, and is committed to or intends to make to agents, brokers or any other intermediaries in connection with the award of the contract and shall adhere to the relevant guidelines issued from time to time by Government of India/ BHEL.

If the Bidder(s) / Contractor(s), before award or during execution of the Contract commit(s) a transgression of the above or in any other manner such as to put his reliability or credibility in question, BHEL is entitled to disqualify the Bidder(s) / Contractor (s) from the tender process or terminate the contract and/ or take suitable action as deemed fit.

PURCHASE EXECUTIVE

ANNEXURE - I
LIST OF INTERNATIONAL GATEWAY AIRPORTS

For airbased consignment, terms of delivery will be on FCA basis from following listed airports only. This list is valid from 01.03.2013 to 28.02.2015. Vendors are requested to verify this list for use after 28.02.2015.

SCHEDULE NO	COUNTRY	CURRENCY CODE	AIRPORT
D01	UK	GBP	LONDON (HEATHROW)
D02	UK	GBP	NEW CASTLE
D03	UK	GBP	OXFORD. CHETLAM
D04	UK	GBP	BRISTOL. WELLINGBOROUGH
D05	UK	GBP	BIRMINGHAM
DO6	UK	GBP	EAST MIDLANDS
D07	UK	GBP	MANCHESTER
D08	UK	GBP	LEEDS
D09	UK	GBP	GLASGOW
D10	FRANCE	EURO	PARIS (ROISSY) & LYON
D11	SWEDEN	EURO	STOCKHOLM
D12	SWEDEN	EURO	GOTHENBERG & MALMO
D13	ITALY	EURO	ROMA, MILAN
D14	ITALY	EURO	TURIN, BOLOGNA, FLORENCE
D15	NETHERLANDS	EURO	AMSTERDAM, ROTTERDAM
D16	AUSTRIA	EURO	VIENNA, LINZ, GRAZ
D17	BELGIUM	EURO	ANTWERP, BRUSSELS
D18	DENMARK	DKK	COPENHAGEN
D19	JAPAN	JPY	TOKYO, OSAKA
D20	SINGAPORE	SGD	SINGAPORE
D21	CANADA	CAD	TORONTO
D22	CANADA	CAD	MONTREAL
D23	USA	USD	NEW YORK, BOSTON
D24	USA	USD	CHICAGO
D25	USA	USD	SAN FRANCISCO, LOS ANGELES
D26	USA	USD	ALANTA, HOUSTON
D27	GERMANY	EURO	MUNICH, KOLN, DUSSELDORF, HANNOVER, HAMBURG, STUTTGART, DAMSTADT, MANIHIEM, NURUMBERG
D28	GERMANY	EURO	FRANKFURT
D29	GERMANY	EURO	BERLIN
D30	SWITZERLAND	SFR	BASLE, ZURICH, GENEVA
D31	SPAIN	EURO	BARCELONA
D32	AUSTRALIA	AUD	SYDNEY
D33	AUSTRALIA	AUD	MELBOURNE
D34	AUSTRALIA	AUD	PERTH
D35	CZECH	EURO	PRAGUE
D36	HONG KONG	HKD	HONG KONG
D37	NEW ZELAND	NZD	AUCKLAND
D38	RUSSIA	USD	MOSCOW
D39	SOUTH KOREA	USD	KIMPO INTERNATIONAL, INCHEON
D40	FINLAND	EURO	HELSINKI
D41	ROMANIA	EURO	BUCHAREST
D42	NORWAY	EURO	OSLO
D43	IRELAND	EURO	DUBLIN
D44	ISRAEL	USD	TEL AVIV
D45	UAE	USD	DUBAI
D46	OMAN	USD	MUSCAT
D47	EGYPT	USD	CAIRO
D48	TAIWAN	USD	TAIPEI
D49	UKRAINE	USD	KIEV
D50	CHINA	USD	SHANGHAI, SHENZHEN
D51	PHILIPINES	USD	MANILA
D52	MALAYSIA	USD	KUALALUMPUR, PE NANG
D53	CYPRUS	USD	LARNACA
D54	SOUTH AFRICA	USD	JOHANNESBERG, DURBAN
D55	SLOVAKIA	EURO	BARTISLOVA
D56	SAUDI ARABIA	SAR	RIYADH
D57	TURKEY	EURO	ISTANBUL
D58	THAILAND	USD	BANGKOK
D59	BRAZIL	USD	SAO PAULO, RIO DE JANEIRO

ANNEXURE – II
DISCREPANCY IN WORDS & FIGURES – QUOTED IN PRICE BID

Following guidelines will be followed in case of discrepancy in words & figures-quoted in price bid:

(a) If, in the price structure quoted for the required goods/services/works, there is discrepancy between the unit price and the total price (which is obtained by multiplying the unit price by the quantity), the unit price shall prevail and the total price corrected accordingly, unless in the opinion of the purchaser there is an obvious misplacement of the decimal point in the unit price, in which case the total price as quoted shall govern and the unit price corrected accordingly.

(b) If there is an error in a total corresponding to the addition or subtraction of subtotals, the subtotals shall prevail and the total shall be corrected; and

(c) If there is a discrepancy between words and figures, the amount in words shall prevail, unless the amount expressed in words is related to an arithmetic error, in which case the amount in figures shall prevail subject to (a) and (b) above.

(d) If there is such discrepancy in an offer, the same shall be conveyed to the bidder with target date upto which the bidder has to send his acceptance on the above lines and if the bidder does not agree to the decision of the purchaser, the bid is liable to be ignored.

ANNEXURE-III
GUIDELINES FOR REVERSE AUCTION PROCEDURE

Against this enquiry for the subject item/ system with detailed scope of supply as per enquiry specifications, BHEL may resort to “REVERSE AUCTION PROCEDURE” i.e., ON LINE BIDDING (THROUGH A SERVICE PROVIDER). The philosophy followed for reverse auction shall be English Reverse (No ties).

1. For the proposed reverse auction, technically and commercially acceptable bidders only shall be eligible to participate.
2. Those bidders who have given their acceptance for Reverse Auction (quoted against this tender enquiry) will have to necessarily submit “online sealed bid” in the Reverse Auction. Non-submission of “online sealed bid” by the bidder for any of the eligible items for which techno-commercially qualified, will be considered as tampering of the tender process and will invite action by BHEL as per extant guidelines in vogue.
3. BHEL will engage the services of a service provider who will provide all necessary training and assistance before commencement of on line bidding on internet.
4. In case of reverse auction, BHEL will inform the bidders the details of Service Provider to enable them to contact & get trained.
5. Business rules like event date, time, bid decrement, extension etc. also will be communicated through service provider for compliance.
6. Bidders have to fax the Compliance form before start of Reverse auction. Without this, the bidder will not be eligible to participate in the event.
7. In line with the NIT terms, BHEL will provide the calculation sheet (e.g., EXCEL sheet) which will help to arrive at “Total Cost to BHEL” like Packing & forwarding charges, Taxes and Duties, Freight charges, Insurance, Service Tax for Services and loading factors (for non-compliance to BHEL standard Commercial terms & conditions) for each of the bidder to enable them to fill-in the price and keep it ready for keying in during the Auction.
8. Reverse auction will be conducted on scheduled date & time.
9. At the end of Reverse Auction event, the lowest bidder value will be known on auction portal.
10. The lowest bidder has to fax/e-mail the duly signed and filled-in prescribed format for price breakup including that of line items, if required, as provided on case-to-case basis to Service provider within two working days of Auction without fail.
11. In case BHEL decides not to go for Reverse Auction procedure for this tender enquiry, the Price bids and price impacts, if any, already submitted and available with BHEL shall be opened as per BHEL’s standard practice.
12. Bidders shall be required to read the “Terms and Conditions” section of the auctions site of Service provider, using the Login IDs and passwords given to them by the service provider before reverse auction event. Bidders should acquaint themselves of the “Business Rules of Reverse Auction”, which will be communicated before the Reverse Auction.
13. If the Bidder or any of his representatives are found to be involved in Price manipulation/ cartel formation of any kind, directly or indirectly by communicating with other bidders, action as per extant BHEL guidelines, shall be initiated by BHEL and the results of the RA scrapped/ aborted.
14. The Bidder shall not divulge either his Bids or any other exclusive details of BHEL to any other party.
15. In case BHEL decides to go for reverse auction, the H1 bidder (whose quote is highest in online sealed bid) may not be allowed to participate in further RA process.

ANNEXURE - IV
Electronic Funds Transfer (EFT) OR
Paylink Direct Credit Form

Please Fill up the form in **CAPITAL LETTERS** only.

TYPE OF REQUEST(Tick one): _____ CREATE _____ CHANGE

BHEL Vendor / Supplier Code:	
Company Name :	
Permanent Account Number(PAN):	
Address	

City:	PINCODE	STATE
-------	---------	-------

Contact Person(s)	
Telephone No:	
Fax No:	
e-mail id:	

1 Bank Name:	
2 Bank Address:	

3 Bank Telephone No:	
4 Bank Account No:	

5 Account Type: Savings/Cash Credit	
6 9 Digit Code Number of Bank and branch appearing on MICR cheque issued by Bank	
7 Bank IFSC Code(applicable for NEFT)	
8 Bank IFSC code(applicable for RTGS)	

(Indian Financial System Code)

- A I hereby certify that the particulars given above are true, correct and complete and that I, as a representative for the above named Company, hereby authorise BHEL, EDN, Bangalore to electronically deposit payments to the designated bank account.
- B If the transaction is delayed or not effected at all for reasons of incomplete or incorrect information, I would not hold BHEL / transferring Bank responsible.
- C This authority remains in full force until BHEL, EDN, Bangalore receives written notification requesting a change or cancellation.
- D I have read the contents of the covering letter and agree to discharge the responsibility expected of me as a participant under ECS / EFT.

Date:

Authorised Signatory:
 Designation:

Telephone No. with STD Code

Company Seal

Bank Certificate

We certify that _____ has an Account No _____ with us and we confirm that the bank details given above are correct as per our records.

Date: _____
 Place: _____ Signature

Please return completed form **along with a blank cancelled cheque or photocopy** thereof to:
 Bharath Heavy Electricals Ltd,
 Attn:
 Electronics Division, Mysore Road,
 BANGALORE - 560 026
 In case of any Query, please call concerned purchase executive.

ANNEXURE - V
PRESENT PROCEDURE FOR SALE IN TRANSIT (HIGH SEA SALES)

In case of High Sea Sales, vendor should submit following documents:

1. ORIGINAL HIGH SEA SALES AGREEMENT

- Sale agreement (on Rs. 200/- non-judicial stamp paper & notarised with 2 witnesses with identity) has to be signed between BHEL and the Party importing material. The date of the sale documents should be in between the date of House Air Way Bill / Bill of Lading and before landing of the goods in Indian origin.
- The date of the stamp paper should be prior to the Air Way Bill / Bill of Lading date.
- Following shall be included in the High Sea Sales Agreement:
“THE BUYER ALSO UNDERTAKE DISCHARGES, THE OBLIGATION AND FULFILLMENT OF CONDITIONS, IF ANY, ATTACHED TO THE IMPORTATION, ASSESSMENT AND CLEARANCE OF THE GOODS IN TERMS CUSTOMS TARIFF ACT 1975, THE CUSTOMS ACT 1962 & RULES & REGULATIONS MADE THERE UNDER AND OTHER RELEVANT ACTS, ORDERS, NOTIFICATIONS”.

2. ORIGINAL INVOICES: INDIGENOUS RUPEE INVOICE & FOREIGN CURRENCY INVOICE

- Prices should be C.I.F., designated airport/seaport basis.
- I.E.C., C.S.T., K.S.T. Nos. to be mentioned.
- Description of item (Nomenclature), Unit & Quantity in both the Foreign Currency & the Indigenous Invoice in Rupee shall be exactly as per Purchase Order Description of item, Quantity and Unit. The Indigenous Invoice value shall be exactly as per Purchase Order value.
- Seller should give Foreign Currency Invoice from the original consignor. The Foreign Currency Invoice value should be at least 2% (two per cent) less than the Indigenous Rupee Invoice value in equivalent foreign currency.

4. ORIGINAL HOUSE AIR WAY BILL/ BILL OF LADING

- The sale agents should duly endorse House Air Way Bill (HAWB) for air shipments or original Bill of Lading (O.B.L.) for sea shipments and Foreign Currency Invoice in favour of BHEL-EDN.

5. ORIGINAL CARGO ARRIVAL NOTICE FROM FORWARDER.

6. ORIGINAL DELIVERY ORDER ISSUED IN NAME OF BHEL-EDN.

7. ORIGINAL PACKING LIST.

8. A LETTER TO THE COMMISSIONER OF CUSTOMS FOR EFFECTING ABOVE SALE.

9. A LETTER TO THE DEPUTY ASSESSOR (OCTROI) FOR EFFECTING ABOVE SALE IN FAVOUR OF BHEL.

REMARKS: In case vendor needs any clarifications on the above, the same may be sought in writing.

Annexure-VI
BHEL MEMBER BANKS (LIST OF CONSORTIUM BANKS)

BANK GUARANTEE (BG) SHALL BE ISSUED FROM THE FOLLOWING BANKS ONLY:

	Nationalised Banks		Nationalised Banks
1	Allahabad Bank	19	Vijaya Bank
2	Andhra Bank		Public Sector Banks
3	Bank of Baroda	20	IDBI
4	Canara Bank		Foreign Banks
5	Corporation Bank	21	CITI Bank N.A
6	Central Bank	22	Deutsche Bank AG
7	Indian Bank	23	The Hongkong and Shanghai Banking Corporation Ltd. (HSBC)
8	Indian Overseas Bank	24	Standard Chartered Bank
9	Oriental Bank of Commerce	25	The Royal Bank of Scotland N.V.
10	Punjab National Bank	26	J P Morgan
11	Punjab & Sindh Bank		Private Banks
12	State Bank of India	27	Axis Bank
13	State Bank of Hyderabad	28	The Federal Bank Limited
14	Syndicate Bank	29	HDFC Bank
15	State Bank of Travancore	30	Kotak Mahindra Bank Ltd
16	UCO Bank	31	ICICI Bank
17	Union Bank of India	32	IndusInd Bank
18	United Bank of India	33	Yes Bank

Note:

- All BGs must be issued from BHEL consortium banks listed above.
- BHEL may accept BG from other Nationalised Banks also which are not listed above.
- BG will not be accepted from Scheduled Banks and Co-operative Banks.
- In case BG is issued from a bank located outside Indian territory and is issued in foreign currency, the BG must be routed through and confirmed by any one of the above mentioned consortium banks or any of the Indian Public Sector Banks.
- This list is subject to changes. Hence vendors are requested to check this list every time before issuing BGs.

ANNEXURE-VII
PROFORMA OF PERFORMANCE BANK GUARANTEE
(For Bank Guarantees issued in Indian Rupees by Banks in India)

Note:

- To be executed in Rs. 100/- Non-Judicial stamp paper.
- To be submitted by issuing bank to Purchase Dept. directly. Please give BHEL address to banker.
- Do not enclose with Bank document.
- Modifications and additions/deletions to this BG format are not permitted.

PERFORMANCE GUARANTEE (PROFORMA OF BANK GUARANTEE)

Ref no: (BG No.) _____

THIS DEED OF GUARANTEE made and executed on the _____ day of _____ (month & year), by the _____ (Bank), registered under the Companies Act 1956/Nationalised Bank constituted under the Banking Companies (acquisition and transfer of undertakings) Act constituted under the **State Bank of India Act / Subsidiary Banks Act**, having its registered / head office at _____ represented herein by its Branch Manager / authorised representatives Sri. _____ & Sri. _____ (Hereinafter called 'guarantor' which term shall mean and include its successors and assigns)

IN FAVOUR OF BHARAT HEAVY ELECTRICALS LIMITED

_____ (Buyer's Name), a company registered under the companies Act, 1956 having its registered office at BHEL House at Siri Fort, New Delhi-110 049 and its Electronics Division at Mysore Road, Bangalore - 26 (hereinafter referred to as the 'Company' Which term shall include its successors and assigns):

Whereas the company has placed an order on _____ (State the name of the company / firm and its address) (hereinafter referred to as the 'Supplier' which term shall mean and include its liquidators, successors and assign) for the supply of system under order / Contract No _____ Dtd _____.

AND WHEREAS the supplier has agreed to supply the materials and carryout the works as detailed and in accordance with the terms set out in the said order / contract.

AND WHEREAS the company is not required to pay to the supplier a sum of Rupees _____ being the 10% of the value of the goods supplied / Works performed / Services rendered under the said order / contract between the supplier and the company, till the company is satisfied with the mechanical Warranties and the performance standards stipulated in the said order / contract between the company and the supplier has been duly fulfilled, except, against a Bank Guarantee for the said sum of Rs. _____ in favour of the company by reputed Bank, in which case the company has agreed to make payment to the supplier of the said sum of Rupees _____ being (10%) of the value of the goods supplied / Works performed / Services rendered under the agreement between the supplier and the company and the Guarantor has at the request of the supplier, agreed to furnish this Guarantee subject to the terms and conditions stated below :

NOW THIS DEED WITNESSES THAT IN pursuance of the above said agreement, the guarantor hereby agrees and covenants with company is as follows:

- 1) That during the period this contract of Guarantee remains effectual, the guarantor shall be liable in respect of the amount due and owing to the company in respect of the payments to the extent of Rs _____ (in words) _____ against any loss or damage caused to or suffered by the company by reasons of any breach of the terms of the said order / contract / Agreement by the supplier
- 2) The Guarantor hereby undertakes to pay the amounts and payable under this guarantee without any demur, merely on demand from the company intimating that the amount claimed is due by way of loss or damage caused to or suffered or would be caused or suffered by any terms contained in the said order/contract. Any such demand made on the guarantor shall be conclusive as regards the amount due and payable by the Guarantor irrespective of the fact whether the contractor/supplier admits or denies.
- 3) The Guarantor further agrees that the agreement herein contained shall remain in force and effect till all supplies to be made /works to be performed / services to be rendered under the said order /contract /agreement are completed to the entire satisfaction of the company or till company certifies that the terms and conditions of the said order / contract agreement have been fully and

properly carried out by the said supplier and accordingly discharges the Guarantee. Unless a demand or claim under this guarantee is made on the guarantor in writing on or before the expiry of claim period indicated in clause 6 below, the guarantor shall be discharged from all the liability under this guarantee thereafter.

- 4) The guarantor further agrees with the company that the company shall have the fullest liberty without the consent of the guarantor and without effecting in any manner the obligations of the guarantor hereunder to vary any of the terms of the said order / contract / agreement or extend the time of performance by the said supplier from time to time or refrain from exercising the power exercisable by the company against the said supplier or to forebear or omit to enforce any of the terms and conditions relating to the said order / contract / agreement, and the guarantor shall not be relieved of its liability in whole or in part, by reason of any act, commission or forbearance on the part of the company or by reason of any such variation, or extension being granted to the said supplier or by reason of any such matter or thing whatsoever which under the law relating to sureties would but for this provision have effect of so relieving the guarantor.
- 5) The guarantor undertakes not to revoke this guarantee during its currency except with the previous consent of the company in writing.
- 6) Notwithstanding anything herein above obtained, the liability of the guarantor under these presents is restricted to Rs._____. The guarantee shall be in force till its expiry on _____ unless a demand is made on the guarantor within SIX months from the date of expiry, all the liability of the guarantor under this guarantee shall stand fully discharged. The decision of the claimant in regard to breach of contract is final and binding on the Bank.

IN WITNESS whereof, the guarantor, acting through its authorised representative has executed this deed of Guarantee on the day, month and year first above written.

(Seal of the Bank to be affixed)
For & On behalf of _____ Bank
Signature of authorized person with
seal & designation

WITNESS:

1.

2.

ANNEXURE-VIII
PROFORMA OF PERFORMANCE BANK GUARANTEE
(For Bank Guarantees issued in Foreign Currency by Banks located outside India)

BANK NAME AND ADDRESS

Electronics Division
Bharat Heavy Electrical Limited (B.H.E.L.),
Mysore Road, P.B. No. 2606,
Bangalore- 560 026

Dear Sir,

Sub : CONTRACT PERFORMANCE GUARANTEE Ref no. Dtd.....

WHEREAS you have entered into a contract reference No & PO NO. _____
Date _____ with M/s _____ having its registered office at
_____ for the supply of _____ as detailed in your purchase
order No. _____ which is hereinafter referred to as "the said contract" and WHEREAS M/s
_____ has undertaken to produce a Bank Guarantee for **10% (Ten Percent)**
of the contract price amounting to _____
(_____) to secure its obligations to Electronics Division, BHEL
having its registered office at New Delhi for the performance of the contract including the warranty of the
equipment supplied, We _____ Bank,
_____ hereby expressly, irrevocably and unreservedly undertake and
guarantee as principal obligors on behalf of M/s _____ that in the event Bharat
Heavy Electricals Ltd. (B.H.E.L.) declares to us in writing that M/s _____
has not fulfilled any obligors according to the contractual obligation of the said contract, to pay you on
demand and without demur to Bharat Heavy Electricals Ltd., Electronics Division, Mysore Road, P.B.No.
2606, Bangalore - 560 026., India an amount of _____
(in words _____) subject to
as may be determined below :

1. Notwithstanding any right M/s. _____ may have directly against or any
disputes raised by M/s. _____, Your written demand shall be conclusive
evidence to us that repayment is due under the terms of the said contract and shall be binding on
us.

2. We shall not be discharged or released from this undertaking and Guarantee by any arrangements, variations made between you and M/s. _____ with or without our consent and knowledge or by any alteration in the obligations of M/s. _____ by any forbearance whether as to payment, time, performance or otherwise.
3. This guarantee shall remain valid until the end of six months after the close of the warranty period or until the same is reported by BHEL to us whichever is earlier.
4. We agree and undertake not to revoke this guarantee during its validity unless discharged in writing by you subject to the provision of clause (7) below :
5. This guarantee shall be a continuing guarantee subject to the foregoing and shall not be discharged by any change in the constitution of the Bank or M/s. _____ .
6. This guarantee shall be governed by and constructed in accordance with the Laws of India.
7. At any time _____ Bank may render this guarantee null and void by paying to Bharat Heavy Electricals Ltd. the full amount being _____ (in words _____)
_____)

**For and On behalf of Bank
By its Authorised Signatory**

Annexure - IX
Certificate by Chartered Accountant on Letter Head

This is to certify that M/s
.....(Hereinafter referred to as 'Company')
having its registered office at is registered under MSMED Act 2006,
(Entrepreneur Memorandum No (Part-II dtd
Category: (Micro/Small). (Copy enclosed).

Further verified from the Books of Accounts that the investment of the company as
on date..... **as per MSMED Act 2006 is as follows:**

- 1. For Manufacturing Enterprises:** Investment in plant and machinery (i.e., original cost excluding land and building and the items specified by the Ministry of Small Industries vide its notification No.S.O.1722 (E) dated October 5, 2006:

- 2. For Service Enterprises:** Investment in equipment (original cost excluding land and building and furniture, fittings and other items not directly related to the service rendered or as may be notified under the MSMED Act, 2006:
Rs.Lacs.

The above investment of Rs. Lacs in within permissible limit of
Rs..... Lacs for.....Micro / Small (Strike off which is not
applicable) Category under MSMED Act 2006.

Date:

(Signature)

Name -

Membership Number -

Seal of Chartered Accountant

Guidelines for Indian Agents
ANNEXURE - X

- **Definition of Indian Agent:** An Indian Agent of foreign principal is an individual, a partnership, an association of persons, a private or public company, that carries out specific obligation(s) towards processing of BHEL tender or finalization or execution of BHEL's contract on behalf of the foreign supplier.

In case of yes, vendor to note the following and reply accordingly:

- i. BHEL shall deal directly with foreign vendors, wherever required, for procurement of goods. However, if the foreign principal desires to avail of the services of an Indian agent, then the foreign principal should ensure compliance to regulatory guidelines - which require mandatory submission of an Agency Agreement.
- ii. It shall be incumbent on the Indian agent and the foreign principal to adhere to the relevant guidelines of Government of India, issued from time to time.
- iii. The Agency Agreement should specify the precise relationship between the foreign OEM / foreign principal and their Indian agent and their mutual interest in the business. All services to be rendered by agent/ associate, whether of general nature or in relation to the particular contract, must be clearly stated by the foreign supplier/ Indian agent. Any payment, which the agent or associate receives in India or abroad from the OEM, whether as commission or as a general retainer fee should be brought on record in the Agreement and be made explicit in order to ensure compliance to laws of the country.
- iv. Any agency commission to be paid by BHEL to the Indian agent shall be in Indian currency only.
- v. Tax deduction at source is applicable to the agency commission paid to the Indian agent as per the prevailing rules.
- vi. In the absence of any agency agreement, BHEL shall not deal with any Indian agent (authorized representatives / associate / consultant, or by whatever name called) and shall deal directly with the foreign principal only for all correspondence and business purposes.
- vii. The "Guidelines for Indian Agents of Foreign Suppliers" enclosed at annexure -'A' shall apply in all such cases.

- viii. The supply and execution of the Purchase Order (including indigenous supplies/ service) shall be in the scope of the OEM/ foreign principal. The OEM/ foreign principal should submit their offer inclusive of all indigenous supplies/ services and evaluation will be based on 'total cost to BHEL'. In case OEM/ foreign principal recommends placement of order(s) towards indigenous portion of supplies/ services on Indian supplier(s)/ agent on their behalf, the credentials/ capacity/ capability of the Indian supplier(s)/ agent to make the supplies/ services shall be checked by BHEL as per the extant guidelines of Supplier Evaluation, Approval & Review Procedure (SEARP), before opening of price bids. In this regard, details may be checked as per Annexure-B (copy enclosed). It will be the responsibility of the OEM/ foreign principal to get acquainted with the evaluation requirements of Indian supplier/ agent as per SEARP available on www.bhel.com.

The responsibility for successful execution of the contract (including indigenous supplies/ services) lies with the OEM/ foreign principal. All bank guarantees to this effect shall be in the scope of the OEM/ foreign principal.

--X--

Vendor's Signature with Seal

Guidelines for Indian Agents of Foreign Suppliers

- 1.0 There shall be compulsory registration of agents for all Global (Open) Tender and Limited Tender. An agent who is not registered with BHEL shall apply for registration in the registration form in line with SEARP.
- 1.1 Registered agents will file an authenticated Photostat copy duly attested by a Notary Public/Original certificate of the Principal confirming the agency agreement and giving the status being enjoyed by the agent and the commission/ remuneration/ salary/ retainership being paid by the principal to the agent before the placement of order by BHEL.
- 1.2 Wherever the Indian representatives have communicated on behalf of their principals and the foreign parties have stated that they are not paying any commission to the Indian agents, and the Indian representative is working on the basis of salary or as retainer, a written declaration to this effect should be submitted by the party (i.e. Principal) before finalizing the order.
- 2.0 **Disclosure of particulars of agents/ representatives in India, if any.**
- 2.1 Tenderers of Foreign nationality shall furnish the following details in their offers:
 - 2.1.1 The Bidder(s)/ Contractor(s) of foreign origin shall disclose the name and address of the agents/ representatives in India if any and the extent of authorization and authority given to commit the Principals. In case the agent/ representative be a foreign Company, it shall be confirmed whether it is existing Company and details of the same shall be furnished.
 - 2.1.2 The amount of commission/ remuneration included in the quoted price(s) for such agents/ representatives in India.
 - 2.1.3 Confirmation of the Tenderer that the commission/ remuneration, if any, payable to his agents/ representatives in India, may be paid by BHEL in Indian Rupees only.
- 2.2 Tenderers of Indian Nationality shall furnish the following details in their offers:
 - 2.2.1 The Bidder(s)/ Contractor(s) of Indian Nationality shall furnish the name and address of the foreign principals, if any, indicating their nationality as well as their status, i.e. whether manufacturer or agents of manufacturer holding the Letter of Authority of the Principal specifically authorizing the agent to make an offer in India in response to tender either directly or through the agents/ representatives.
 - 2.2.2 The amount of commission/ remuneration included in the price (s) quoted by the Tenderer for himself.
 - 2.2.3 Confirmation of the foreign principals of the Tenderer that the commission/ remuneration, if any, reserved for the Tenderer in the quoted price(s), may be paid by BHEL in India in equivalent Indian Rupees on satisfactory completion of the Project or supplies of Stores and Spares in case of operation items.
- 2.3 In either case, in the event of contract materializing, the terms of payment will provide for payment of the commission/ remuneration, if any payable to the agents/ representatives in India in Indian Rupees on expiry of 90 days after the discharge of the obligations under the contract.
- 2.4 Failure to furnish correct and detailed information as called for in paragraph 2.0 above will render the concerned tender liable to rejection or in the event of a contract materializing, the same liable to termination by BHEL. Besides this there would be a penalty of banning business dealings with BHEL or damage or payment of a named sum.

Disclaimer Certificate For Deemed Export Benefits

I, (Name & Designation)on behalf of M/s. (Name and address of the supplier) hereby certify that we have supplied the following goods to M/s..... (Name and address of the recipient):

S.No.	Inv. No. & date	Description of goods	Unit	Qty.	Value

1. We are the manufacturer exporters/suppliers and are registered/not registered with Central Excise and have not availed and will not avail CENVAT facility in respect of the input/components used in aforesaid supplies. We have also not availed and will not avail rebate on the inputs/components used in aforesaid supplies.

OR

We are the suppliers and our supporting manufacturer(s) is/are registered/not registered with Central Excise and have not availed and will not avail CENVAT facility in respect of the inputs/components used in aforesaid supplies.

2. We also certify that we have not been issued any Advance Authorization/Duty Free Import Authorization in respect of the aforesaid supplied goods and have not availed any benefit thereon.

3. We further state that we have not drawn nor will draw any benefit for deemed export and we have no objection if M/s..... (Name and address of the recipient) draws the deemed export benefits on the supplies mentioned above. (Required to be given in case benefits are claimed by recipient of goods).

OR

We have not given disclaimer certificate to M/s..... (Name and address of the recipient) and will not give disclaimer certificate, in future, in respect of these supplies for claiming deemed export benefits (Required to be given in case benefits are claimed by DTA suppliers).