



**BHARAT HEAVY ELECTRICALS LIMITED**

**HEEP HARIDWAR INDIA-PIN 249403**

**FAX NO: 0091 1334 226462**

**PHONE NO: 0091 1334 284593**

Enq. No.: **L/6452/2014/5855/D1**

Date : 25/04/2015

M/S.....

Sub: BHEL-HEEP/OPEN-TENDER (TL & D)/2015

Dear Sir,

The Heavy Electricals Equipment Plant (HEEP) located in Haridwar, India is one of the major manufacturing plants of Bharat Heavy Electricals Ltd. The core business of HEEP includes design and manufacture of large steam and gas turbines, turbo generators and so on.

Sealed tenders with the Tender No. and opening date clearly super scribed on the cover are invited from the manufacturers (registered as well as unregistered) for the supply of the following items:-

| Sl. No. | Tender No.                 | Description of Item | Qty.                | Opening Date      |
|---------|----------------------------|---------------------|---------------------|-------------------|
| 1       | <b>L/6452/2014/5855/D1</b> | Ref: Annexure-1     | Ref:<br>Annexure-1. | <b>30.05.2015</b> |

The details with required delivery are given in **Annexure-1**.

The tender documents can be downloaded from our web site [www.bhel.com](http://www.bhel.com) or [www.bhelhwr.co.in](http://www.bhelhwr.co.in), after downloading the tender documents from web site, while submitting the tender as detailed in "Instruction to Bidders", intending vendors must remit tender fee of Rs. 2,000.00 against each tender along with the requisite EMD of Rs. 40,000/- in the form of Cash (as permissible under Income Tax Act) / Pay Order / Demand draft. **EMD in the form of Cheque / Bank Guarantee are not acceptable. If EMD or tender fees are not submitted than the offer may be out rightly rejected.** As per notification reference no.

NSIC/HO/GP/15(4)/2013-14 dated 07.07.2013 Micro & Small Enterprises (MSEs) is not required to submit EMD or tender fees. A certificate issued from competent authority shall be submitted in support of Micro & Small Enterprises (MSEs). BHEL will not be responsible for any type of postal delay / incomplete information from vendor.

Central / State – PSUs / Government departments are exempted from submission of EMD subject to approval by BHEL management.

**The date for opening of tender shall be 30.05.2015.** Tenders will be received up to 1.45 P.M. on **30.05.2015** and opened on the same day at 2.00 P.M. in the Tender Room. **Please note that tender received after due date & time (1.45PM on 30.05.2015) will not be REPEAT will not be opened.** BHEL will not be responsible for any type of postal / courier delay.

Specifications & Drawing of the above items are available on our above mentioned website with links provided for all Specifications, Drawings & Annexure (At the end of this document). Amendments/Corrigendum, if any, will be hosted on our web site only. Other terms and conditions will be as per tender documents.

**The total quantity may undergo change at the time of ordering.**

Please submit your Techno-Commercial offer only for the above requirement subject to our terms and conditions.

BIDS shall be opened at 2 PM on the due date in the presence of authorized representative of the bidders who may like to be present. The authorized representative should bring authority letter from their parent company (Manufacturer) for the specific tender no. attending the bid opening.

BHEL will forfeit the EMD if, the successful bidder / vendor refuses to honor the order after award of the same on him and / or withdraws his bid and / or unilaterally changes the offer and / or any of its terms & conditions within the validity period.

**KINDLY READ “INSTRUCTIONS TO BIDDERS.” QUOTATION NOT IN ACCORDANCE WITH THE INSTRUCTIONS ARE LIABLE TO BE DISQUALIFIED AND IGNORED.**

## INSTRUCTIONS TO BIDDERS FOR OPEN TENDER

### 1.0 DEFINITION

Registered Vendors - Are those who are registered with BHEL, Haridwar for Megawatt rating/ Size/ Weight of tendered components in respective steel grade or machining of such components.

Un-registered Vendors - Are those who are not registered with BHEL, Haridwar for Megawatt rating/ Size/ Weight of tendered components in respective steel grade or machining of such components.

### 2.0 TECHNICAL QUALIFICATION

- Enclosed format – Annexure-1 to be submitted. It is the mandatory requirement. Offer of Vendors not meeting these requirements may not be considered.

### 3.0 ESSENTIAL INSTRUCTIONS

1. All un-registered vendors shall be approved by BHEL, if found suitable, on the basis of data furnished by them in Supplier Registration Form (SRF) Foreign Vendors or Indigenous Vendors. Vendor (s) shall not be considered for ordering if not approved by BHEL.
2. BHEL team may visit the vendor (s) works for verification of capability and capacity claimed in tender documents/offer (s).
3. The tenders shall be submitted in three parts as described below on or before the due date. Vendor Registration Form shall be submitted by unregistered vendors only.

- i. Part I (Envelop I) – A. EMD & Tender Fee

Or

Valid certificate towards exemption of EMD & tender fee, applicable for Micro and small Enterprises, as mentioned below:

MSE Suppliers can avail the intended benefits only if they submit along with the offer, attested copies of either EM II certificate having deemed validity (five years from the date of issue of acknowledgement in EM II) or valid NSIC certificate or EM II certificate along with attested copy of a CA certificate (format enclosed where deemed validity of EM II certificate of five years has expired) applicable for the relevant financial year (latest audited). Date to be reckoned for determining the deemed validity will be the date of bid opening (Part 1 in case of two part bid). Non submission of such documents will lead to disqualification of their offer. Documents should be notarized or attested by a Gazetted Officer.

B. Pre-Qualifying Requirement (PQR) – refer Annexure – 1.

C. Vendor Registration Form (SRF documents to be placed separately in part-I and not to be mixed with other documents). Applicable for those who are not registered with BHEL, Haridwar

- ii. Part II (Envelop II) - Techno -Commercial Bid

- iii. Part III (Envelop III) - Price Bid

4. The Quotation should be from the Principal / Original Manufacturer, failing which the quotation is likely to be ignored. However, if OEM / Principal insist on engaging the services of an agent, such agent shall not be allowed to represent more than one manufacturer / supplier in the same tender. Moreover, either the agent could bid on behalf of the manufacturer / supplier or the manufacturer / supplier could bid directly but not both. In case bids are received from both, the manufacturer / supplier and the agent, bid received from the agent shall be ignored. In Case the quotation is submitted through agent, the quotation must accompany original authorization letter from the Principal / Original Manufacturer.
5. The bidders will have to submit ink-signed offer / bid in original directly to BHEL. **Unsigned bids shall be ignored.** The offers of the bidders who are on the banned list as also the offers of the bidders, who engage the services of the banned firms, shall be rejected. The list of banned firms is available on web site www.bhel.com
6. The suppliers or their authorized person may be allowed to attend the tender opening, if duly authorized by their principals, through a specific letter for a particular enquiry or for specific price bid opening on that particular day. General authorization letter is not acceptable
7. Any corrections / amendments shall be properly & fully authenticated with signature. No overwriting is acceptable.

8. Compliance of technical/ commercial terms and conditions as per Annexure-1
9. Part-I will be opened on the date and time specified in the tender notice in the presence of those vendors who wish to attend.
10. Part-II bid will be opened of the vendors who successfully qualify the PQR requirements and have submitted tender fees & EMD or valid certificate towards exemption of EMD & tender fee, applicable for Micro and small Enterprises.
11. Part – III (Price Bids) along with supplementary price bids, if necessary, will be opened at a later date of only those bidders whose techno-commercial bid has been found acceptable.
12. Vendor to quote best possible deliveries in the offer. Offers of those vendors may not be considered if it is not found suitable to BHEL requirement.
13. Currency exchange rate will be applicable on the date of opening of Part-I for evaluation purpose.
14. Depending upon the delivery suitability, BHEL reserves the right to split order on more than one vendor.
15. Tenders when finalized shall be in the name of the bidder only and change of name during tender evaluation (without certificate from registrar of company) and after submission of the tender is liable to make the offer ineligible for participation.
16. BHEL reserves the right to open the price bid (part-III) along with the opening of techno-commercial offer at its option and in that case vendor will be informed accordingly.
17. Total weight -- /Gross / Net in Kg. & also package size essentially should be indicated if not exact then approximate.
18. BHEL will evaluate the technical bids against essential criteria/requirements. BHEL may seek clarifications, if required, from the qualified bidders only. These clarifications will be communicated to the eligible vendors. The offers of those bidders, who are unable to respond in specified time frame, are likely to be ignored.
19. Please resolve your rejections and unexecuted overdue purchase orders immediately which are posted at website.
20. Please confirm that prices quoted are not more than the prices quoted any other BHEL unit.
21. EMD submitted shall be refunded to resp L1 vendors after successful PO execution and for rest of vendors after price bid Opening
22. As per directives of CENTRAL VIGILANCE COMMISSION, GOVERNMENT OF INDIA, One Agent can not represent two or more suppliers or quote on their behalf in a particular tender. If so found at any stage, BHEL-Hardwar is likely to cancel Enquiries/P.O.s to such suppliers. Further such Indian Agents are likely to be de-listed (Black listed for business from BHEL).
23. Vendor should quote price and delivery details as per commercial terms & conditions enclosed.
24. BHEL may load maximum penalty under Late Delivery Clause, to the extent the same is not agreed by the vendor, for the purpose of comparative statement. Where deliveries quoted by Vendors are not suiting, BHEL may also ignore the offer of the vendor.
25. RISK PURCHASE: In case of delays in supplies / defective supplies or non- fulfillment of any other terms and conditions given in Purchase Order the purchaser may cancel the Purchase Order in full or part thereof, and may also make the purchase of such material from elsewhere / alternative source at the risk and cost of the supplier. Vendors do not agree to the above RISK PURCHASE CLAUSE and in eventuality of RISK PURCHASE, may be banned for business with BHEL.
26. Please quote your rates with both the options (a) C&F Landing port & (b) FOB dispatching port (For foreign Vendors). In case of FOB dispatching port, BHEL will add sea freight, insurance and administrative charges for comparison purpose. The offers of vendors not quoting FOB prices in their offers submitted through tender room shall not be considered and will stand rejected out rightly (except high sea sales case).
27. Please quote your rates in your currency or Indian Rupees.
28. The vendor must indicate the name of port of loading in their offer.
29. While submitting your bids please clearly indicate:
  - (a) Expected Weight of goods (lots wise).
  - (b) The size of packed goods.
  - (c) Whether the goods can be despatched in containers?
30. As per the Indian Law, all consignments being imported into India by air/sea require a phytosanitary certificate from the country of origin-if articles have been packed with packaging materials. This is mandatory.
  - Packaging material means any kind of material of plant origin used for packing which include hay, straw wood shavings, wood chips, saw dust,wood waste, wooden pallets, dunnage mats, wooden packages, coir pith, peat or sphagnum moss etc.
  - Please confirm in your offer/despatch documents that the required phytosanitary certificate will be submitted.
31. The offer should be accompanied with relevant copies of catalogues,drawings

Or specification. If these documents are not furnished the offer is liable to be rejected.

32. Please quote your rates on FOR destination basis only (For Indigenous Vendors). Quotations on other than FOR destination basis are liable to be rejected. However, the insurance will be arranged by BHEL.
33. The vendor shall have to pay 5% incidental charges while taking back supplied material if it is found rejected on receipt. The rejected material shall be sent back only after receipt of replacement.
34. SETTLEMENT OF DISPUTES
- Indigenous Vendors: In all cases of dispute the matter shall be referred for arbitration to any arbitrator to be appointed by the Executive Director or any officer who is the administrative head of Bharat Heavy Electricals Ltd., at Haridwar. The venue of arbitration shall invariably be Ranipur Haridwar. The award of the arbitrator shall be final and binding on both the parties. The arbitrator shall have the power to extend, from time to time, the time for making his award with the consent of the parties.
  - Foreign Vendors: In the event of any dispute or difference arising between the parties to this contract regarding execution of same or their respective rights and liabilities there under, the same shall except as otherwise expressly provided therein, be referred to the arbitration of the two arbitrators, one to be appointed by each party; or in the case of the said arbitrators not agreeing then an umpire to be appointed by the two arbitrators in writing before entering on that reference and provisions of the Indian Arbitration Act, 1940 or any statutory notification, or re-enactment therefore and rules framed there under from time to time shall apply to such arbitration. If the two arbitrators do not agree on the appointment of umpire, the nomination of the umpire shall be done by the International Chamber of Commerce, Paris (France). The decision of arbitrators, or in case of their not agreeing, that of the said umpire shall be binding both on seller and purchaser. The venue of the arbitration invariably be New Delhi.
35. JURISDICTION
- All question, dispute or differences arising under, out of or in connection with the purchase order
- Shall be subject to the exclusive jurisdiction of Haridwar courts.
36. OVER RIDING CLAUSE
- All stipulations made in any correspondence other than those exchanged in regards to "Instruction" in our tender documents / enquiry for submission of your offer, if at all shall be void to the extent they are repugnant to the conditions contained herein above and in the purchase order.
37. FINALITY OF MANAGEMENT DECISION
- At all places in the preceding clauses BHEL Management's decision shall be final.

#### **4.0 GENERAL INSTRUCTIONS**

**PART-I (EMD & tender fees (or exemption certificate), PQR and SRF in envelope - I) shall comprise of following documents:**

- a. Annexure-1 for Pre-qualification requirement. Point wise reply to all the points mentioned in Pre- Qualifying Requirement specified in the tender. Relevant documents as requested in Pre-Qualifying Requirement must be attached.
- b. Vendor Registration Form (SRF)  
(Annexure-4 for Foreign Vendors & Annexure-5 for Indigenous Vendors)

The SRF duly filled up will be assessed for manufacturing capability quality systems being followed, organizational soundness and financial worthiness. The same shall be submitted with Part-I by un-registered vendor only with BHEL, HEPP, Haridwar. BHEL registered vendors (registered with permanent code M, N, S) need not to submit SRF.

For vendors registered with T code, SRF is to be submitted essentially along with the offer.

- c. Non-disclosure agreement as per Annexure.6. The agreement shall be duly stamped & signed.

**PART-II (Technical clarification in envelope - II) shall comprise of following documents:**

- a. Complete technical offer.
- b. Annexure-3 for compliance of technical/ commercial terms and conditions.

- d. Complete technical offer as per specification, drawings, technical requirement along with un-priced bid indicating FOB, C&F rate, for destination (Indigenous Vendor) and delivery schedule.
- e. Validity of offer to be indicated.
- f. Deviation with reference to specification/drawing, if any, should be clearly indicated on a separate sheet.
- g. Copy of price Bid (without prices).
- h. Any additional documents.

### **PART –III (Price Bid)**

- a. Price bid with prices to be submitted as part-II of the tender.
- b. If price bid is not submitted along with Part-I bid, the offer will be rejected outrightly.
- c. In case of foreign vendors, prices to be quoted on FOB basis separately. In case of FOB, Loading port must be mentioned. However, for air shipment the rates to be quoted on CPT destination port basis. And air freight charges to be indicated separately in price bid. Further non-availability of flight will not be accepted for rescheduling the delivery or waiver of penalties on account of delayed delivery.
- d. In case of Indigenous vendor, prices must be quoted on FOR-Destination-CPS-HEEP-BHEL basis. However, the insurance will be arranged by BHEL. Vendor can dispatch good through any Indian Bank Association approved transporters having their branch at Haridwar / destination. For the convenience name and address of transporters approved by IBA and BHEL are posted at website [www.bhelhwr.co.in](http://www.bhelhwr.co.in). Further, non-availability of BHEL approved transporter will not be accepted for rescheduling of delivery or waiver of penalties.
- e. Insurance during transportation shall be taken care of by BHEL.
- f. Applicable sales Tax, Excise duty, service tax, educational cess and any other statutory levy should be indicated separately and clearly in the quotation.
- g. **Prices are to be written in both Figures & Words. In case of any difference between the two, If there is a discrepancy between words and figures, the amount in words shall prevail for evaluation and establishing L1 status.**
- h. **LD Penalty shall be applicable at the rate of ½% (half percent) per week or part thereof subject to a maximum of 10% of the value of delayed portion of the order. In case of any variation in LD penalty acceptance, your prices shall be loaded to the extent LD penalty not accepted by you. If**
- i. Payment shall be released after successful machining by any tool of each material code independently as per pt no 8 of annexure-1.
- j. **The comparison between foreign and indigenous bids shall be done based on the Total Landed cost at Destination basis.**

### **Note:**

After tender opening (Part-I), if it is found that :

- The bidder has not submitted the requisite Tender Fee and EMD (If applicable)
- The bidder has claimed to be an MSE vendor but no supporting documents have been submitted in this regard.

In both the above cases the offer of the bidder shall be straightaway rejected and no correspondence from the bidder in this regard shall be entertained.

However, offer of the bidder shall be treated as per the guideline in case the bidder has claimed to be an MSE vendor and submitted requisite MSE documents.

BHEL reserves the rights to place order for tendered quantity on more than one vendor.

### **Superscription on envelopes:**

The following shall be super scribed on the envelopes:

### **PART-I**

1. TENDER NO. AND ITEMS DESCRIPTION
2. DUE DATE FOR OPENING.
3. TENDER FEE, EMD (IF APPLICABLE) OR MSE CERTIFICATE TOWARDS EXEMPTION OF EMD & TENDER FEE

4. PRE- QUALIFYING REQUIREMENT (PQR)

5. SUPPLIER REGISTRATION FORM (SRF)

**PART-II**

1. TENDER NO. AND ITEMS DESCRIPTION

2. DUE DATE FOR OPENING OF PART-I.

3. TECHNO-COMMERCIAL BID

**PART-III**

1. TENDER NO. AND ITEMS DESCRIPTION

2. DUE DATE FOR OPENING OF PART-I

3. PRICE BID

The part-I, part-II & part-III shall be individually sealed and super scribed as indicated above and shall be enclosed further in the envelope duly sealed and super scribed as:

“TENDER FOR (ITEM NAME) AGAINST TENDER NO. ----- DUE ON -----  
CONTAINING PART-I & PART-II OF THIS OFFER.” Vendor’s full name and address should be clearly mentioned on the envelope and shall be addressed to:

To,

Head of Materials Management,

Heavy Electrical Equipment Plant,

BHEL,

Hardwar- 249403

Envelopes not marked as above are liable to be ignored and will not be opened.

**IN CASE YOU ARE NOT MAKING AN OFFER AGAINST THIS ENQUIRY, THEN PLEASE ARRANGE TO SEND A LETTER OF REGRET IF YOU HAVE COLLECTED THE TENDER DOCUMENTS FROM BHEL**

## Annexure- 1

|        | TENDER NO:L/6452/2014/5855D1  |                   |      |
|--------|---|-------------------|------|
| Sl No. | Description of Item   | Delivery required | Qty. |
| 1      | AAA212814265 DRG.NO.-R2128-1426<br>SET OF LH CRANK FACE GROOVING<br>TOOL W=8 CONSISTING OF TOOL<br>HOLDER, INSERT, SPARE, KEYS, ETC.<br>WITH QTY. AS PER SL.NO.-1 OF<br>CAT.-1 OF ANNEXURE-1        | 31/08/15          | 1    |
| 2      | AAA212814273<br>DRG.NO.-R2128-1427<br>SET OF RH CRANK FACE GROOVING<br>TOOL W=8 CONSISTING OF TOOL<br>HOLDER, INSERT, SPARE, KEYS, ETC.<br>WITH QTY. AS PER SL.NO.-2 OF<br>CAT.-1 OF ANNEXURE-1     | 31/08/15          | 1    |
| 3      | AAA212814206<br>DRG.NO.-R2128-1420<br>SET OF LH CRANK FACE<br>GROOVING TOOL W=6<br>CONSISTING OF TOOL<br>HOLDER,INSERT,SPARE ,<br>KEYS,ETC. WITH QTY. AS<br>PER SL.NO.-3 OF CAT.-2<br>OF ANNEXURE-1 | 31/08/15          | 1    |
| 4      | AAA212814214<br>DRG.NO.-R2128-1421<br>SET OF RH CRANK FACE<br>GROOVING TOOL W=6<br>CONSISTING OF TOOL<br>HOLDER, INSERT,SPARE,<br>KEYS,ETC. WITH QTY. AS<br>PER SL.NO.-4 OF CAT.-2<br>OF ANNEXURE-1 | 31/08/15          | 1    |
| 5      | AAA212814222<br>DRG.NO.-R2128-1422<br>SET OF LH CRANK FACE<br>GROOVING TOOL W=6<br>CONSISTING OF TOOL<br>HOLDER,INSERT,SPARE ,<br>KEYS,ETC. WITH QTY. AS<br>PER SL.NO.-5 OF CAT.-2<br>OF ANNEXURE-1 | 31/08/15          | 1    |
| 6      | AAA212814230<br>DRG.NO.-R2128-1423<br>SET OF RH CRANK FACE<br>GROOVING TOOL W=6<br>CONSISTING OF TOOL<br>HOLDER,INSERT,SPARE,<br>KEYS,ETC. WITH QTY. AS<br>PER SL.NO.-6 OF CAT.-2<br>OF ANNEXURE-1  | 31/08/15          | 1    |

|    |  |          |   |
|----|--|----------|---|
| 7  | AAA212814249<br>DRG.NO.-R2128-1424<br>SET OF LH CRANK FACE<br>GROOVING TOOL W=6<br>CONSISTING OF TOOL<br>HOLDER,INSERT,SPARE,<br>KEYS,ETC. WITH QTY. AS<br>PER SL.NO.-7 OF CAT.-2<br>OF ANNEXURE-1         | 31/08/15 | 1 |
| 8  | AAA212814257<br>DRG.NO.-R2128-1425<br>SET OF RH CRANK FACE<br>GROOVING TOOL W=6<br>CONSISTING OF TOOL<br>HOLDER,INSERT,SPARE,<br>KEYS,ETC. WITH QTY. AS<br>PER SL.NO.-8 OF CAT.-2<br>OF ANNEXURE-1         | 31/08/15 | 1 |
| 9  | AAA212814303<br>DRG.NO.-R2128-1430<br>SET OF LH CRANK FACE<br>GROOVING TOOL W=6<br>CONSISTING OF TOOL<br>HOLDER,INSERT,SPARE,<br>KEYS,ETC. WITH QTY. AS<br>PER SL.NO.-9 OF CAT.-2<br>OF ANNEXURE-1         | 31/08/15 | 1 |
| 10 | AAA212814281<br>DRG.NO.-R2128-1428<br>SET OF LH CRANK FACE<br>GROOVING TOOL W=4<br>CONSISTING OF TOOL<br>HOLDER,INSERT,SPARE ,<br>KEYS,ETC.WITH QTY. AS<br>PER SL.NO-10 OF CAT.-3<br>OF ANNEXURE-1         | 31/08/15 | 1 |
| 11 | AAA212814290<br>DRG.NO.-R2128-1429<br>SET OF LH CRANK FACE<br>GROOVING TOOL W=5<br>CONSISTING OF TOOL<br>HOLDER,HOLDER,INSERT,<br>SPARE ,KEYS,ETC. WITH<br>QTY. AS PER SL.NO-11 OF<br>CAT.-3 OF ANNEXURE-1 | 31/08/15 | 1 |
| 12 | AAA212814311<br>DRG.NO.-R2128-1431<br>SET OF LH CRANK FACE<br>GROOVING TOOL W=4<br>CONSISTING OF TOOL<br>HOLDER,INSERT,SPARE ,<br>KEYS,ETC.WITH QTY. AS<br>PER SL.NO-12 OF CAT.-3<br>OF ANNEXURE-1         | 31/08/15 | 1 |

- Vendor should quote best possible delivery in offer. Delivery is not sacrosanct.

## **Annexure-1**

**Supply and successful establishment of Tooling packages consisting of Set of L-Type Face Grooving Tools with Index able carbide Inserts & other consumables for rough & finish grooving of T-portion (left/right side) of various sizes of Grooves for Blades in Steam Turbine casings on CNC Vertical Borer as per details given below :**

### **Pre-Qualifying Conditions for Qualification of Participating Vendor:**

- a) Only those vendors to quote who are Original tool manufacturer or authorized dealer/distributor of Original tool manufacturer. Authorization certificate from Original tool manufacturer to be furnished by the vendor with the offer.
- b) Vendor should have supplied square shank L-Type Face grooving tools with coated carbide grooving inserts of width 4mm or more as part of their standard product range. In support of it, copies of relevant pages of standard product range of Original tool manufacture is required to be submitted.

The following information is to be submitted by the participating vendor about the companies where such type of L-type face grooving tools with coated carbide grooving inserts of width 4mm or more have been supplied. This is required from all the vendors for qualification of their offer.

- 1) Name and address of the customer / company where such tool have been supplied.
- 2) Name, designation, phone no. & email address of the contact person of the customer.
- 3) Month & Year of tool supply
- 4) Basic details of supplied tool like width of grooving insert, shank cross-section, diameter range for face grooving, grooving depth & type of job.
- 5) The participating vendor should confirm satisfactory performance of tool supplied to referred customer.

BHEL reserves the right to verify the information provided by vendor. In case the information provided by vendor is found to be false/ incorrect, the offer shall be rejected.

**Annexure-1**

**Annexure-A**

**Supply and successful establishment of Tooling packages consisting of Set of L-Type Face Grooving Tools with Indexable carbide Inserts & other consumables for rough & finish grooving of T-portion (left/right side) of various sizes of Grooves for Blades in Steam Turbine casings on CNC Vertical Borer as per details given below :**

1. The vendor to offer the tooling packages for Face grooving operation (rough & finish grooving on both left & right sides) on T-portion of various sizes of Grooves for Blades in Steam Turbine Casing on CNC Vertical Borer (refer 10'e'). The material properties of steam turbine casings are mentioned at point no. 9.
2. Vendor can offer tooling packages for any one or more categories as mentioned below at point no. 4. However, offers for each category shall be considered complete & evaluated only if all the items in that category are offered.
3. Evaluation of offers shall be done separately for each category. Accordingly, L1 vendor shall be decided separately for each category and shall be based on total price of all the items in that category.
4. The various categories of tooling package with their items & quantity are as below :

| S. No. | Tool Drg No. | Quantity | Quantity per set |         |   |                               |
|--------|--------------|----------|------------------|---------|---|-------------------------------|
|        |              |          | Tool Holder      | Inserts | Spare parts (shims,screws etc of each type) | Keys/ spanners (of each type) |

| <b>Tooling package of Category-1 (Insert Width =8mm)</b> |            |               |          |            |           |          |
|--|------------|---------------|----------|------------|-----------|----------|
| 1  | R2128-1426 | 1 set         | 4        | 100        | 10        | 4        |
| 2  | R2128-1427 | 1 set         | 4        | 100        | 10        | 4        |
| Total quantity of Category-1                             |            | <b>2 sets</b> | <b>8</b> | <b>200</b> | <b>20</b> | <b>8</b> |

| <b>Tooling package of Category-2 (Insert Width =6mm)</b> |            |               |           |            |           |           |
|--|------------|---------------|-----------|------------|-----------|-----------|
| 3  | R2128-1420 | 1 set         | 4         | 60         | 10        | 4         |
| 4  | R2128-1421 | 1 set         | 4         | 60         | 10        | 4         |
| 5  | R2128-1422 | 1 set         | 4         | 60         | 10        | 4         |
| 6  | R2128-1423 | 1 set         | 4         | 60         | 10        | 4         |
| 7  | R2128-1424 | 1 set         | 4         | 60         | 10        | 4         |
| 8  | R2128-1425 | 1 set         | 4         | 60         | 10        | 4         |
| 9  | R2128-1430 | 1 set         | 4         | 60         | 10        | 4         |
| Total quantity of Category-2                             |            | <b>7 sets</b> | <b>28</b> | <b>420</b> | <b>70</b> | <b>28</b> |

| <b>Tooling package of Category-3 (Insert Width =4mm / 5mm as shown in drgs)</b> |            |               |           |            |           |           |
|---|------------|---------------|-----------|------------|-----------|-----------|
| 10  | R2128-1428 | 1 set         | 4         | 100        | 10        | 4         |
| 11  | R2128-1429 | 1 set         | 4         | 120        | 10        | 4         |
| 12  | R2128-1431 | 1 set         | 4         | 100        | 10        | 4         |
| Total quantity of Category-3  |            | <b>3 sets</b> | <b>12</b> | <b>320</b> | <b>30</b> | <b>12</b> |

**Annexure-1**  
**Annexure-A**

5. The trial machining with one tool for technical acceptance of offers as per point no. 6, Step-3 shall be based on the participating categories as per following :
- i) Case-1: If the vendor has offered tooling package for Category-1 only, then the trial machining shall be done with any tool of the category-1 on acceptance by BHEL.
  - ii) Case-2: If vendor has offered tooling package for Category-2 or Category-1 & 2, then the trial machining shall be done with any tool of the category-2 on acceptance by BHEL.
  - iii) Case-3: If vendor has offered tooling package for Category-3 or Category 1 & 3 or Category 2 & 3 or Category 1, 2 & 3, then the trial machining shall be done with any tool of the category-3 on acceptance by BHEL.

**6. Technical acceptance of offers in following steps :**

- Step-1 Scrutiny of offers for qualification against compliance to Pre-Qualifying condition.
- Step-2 Technical scrutiny of those offers of vendors who have been qualified in compliance to Pre-Qualifying Conditions
- Step-3 For preliminary accepted offers after Step-1 & Step-2, vendors shall be communicated to bring one no. of tool holder (as per point no. 5) & sufficient numbers of its matching inserts & other consumables at their own cost for trial machining of roughing and finishing of two nos. of side grooves. The trial machining shall be carried out at BHEL, Haridwar at mutually agreed schedule as per availability of component and shall be considered successful as per criteria mentioned below at point no. 7. No payment shall be made by BHEL to vendors for trial machining & inserts consumed during trial machining. The vendors may carry back their remaining inserts & tool holder after trial machining. The programming support shall be provided by BHEL.
- Step-4 Only those vendors who shall be successful in trial machining with acceptance by BHEL shall be considered for further processing i.e. price bid opening & ordering on L1 basis, separately for each category, as per purchase policy. In case of non-acceptance of trial machining by BHEL, the offer will not be considered for further processing and hence, considered as technically, not acceptable for any category.

**7. Conditions for Successful trial machining :**

- i) The trial machining shall be carried out, as per BHEL process plan (Fig C & D), using single insert/cutting edge in Steam Turbine casing on suitable CNC Vertical Borer at mutually agreed schedule as per availability of component for operations as per iii) and cutting parameters as per ii) mentioned below.
- ii) Cutting parameters: Tool and its insert should be capable of taking grooving cut with Feed  $F=0.08\text{mm/rev}$  or more and Cutting Speed  $V_c=40\text{m/min}$  or more for first plunge/grooving cut (with both points of tool engaged for cutting) and  $F=0.12\text{mm/rev}$  or more and  $V_c=50\text{m/min}$  or more for remaining cuts (with only one point of tool engaged for cutting).
- iii) Rough grooving without vibrations & bending of tool and with smooth chip flow/chip breaking. Finish grooving/turning without vibrations & bending of tool and with smooth chip flow/chip breaking to achieve required size tolerance and surface finish of 3.2 microns Ra or better with no chatter marks on machined surface.
- iv) Same insert/cutting edge should be used for both roughing and finishing in a groove.
- v) Life of insert/edge should be minimum for 2 side grooves i.e. roughing & finishing in two side grooves with single insert/edge.

**8. Final Acceptance of supplied tools**

- a. Payment against each set of tools, supplied in a category, shall be made independently, subject to successful machining by any tool of the respective set and on acceptance by BHEL.

The trial machining shall be carried out on a suitable Vertical Borer with Job (Casing or test piece as per availability) & CNC program provided by BHEL using any one tool out of set of 4 tool holders as per criteria elaborated above for successful machining at point no. 7. in presence of vendor.

- b. In case of failed machining w.r.t. point no 7, all items supplied for that set shall be declared as rejected and no payment shall be made for any supplied items of that rejected set.

**9. Material of Steam Turbine Casing (casting) :**

Steel Casting with Identification Gx12CrMoVNbN 9-1

Chemical Composition (in weight %) :

C (0.11-0.14), Si (0.2-0.5), Mn (0.4-0.8), P ( $\leq 0.02$ ), S ( $\leq 0.01$ ), Cr (8.0-9.5), Mo (0.9-1.05), V (0.18-0.25), Ni ( $\leq 0.4$ ), Al ( $\leq 0.02$ ), N (0.04-0.06)

Mechanical Properties : 0.2%PS  $\geq 500$  N/mm<sup>2</sup>, UTS : 630-750 N/mm<sup>2</sup>, El (l=5d):  $\geq 16\%$ , Ra :  $\geq 40$  %, Impact :  $\geq 35$ J .

Hardening temp shall be between 1040 & 1070 deg C & tempering temp between 730 & 750 deg C.

**10. Other Conditions :**

- Category wise Tooling package i.e. tool holders, inserts, spare parts, keys/spanners etc. for respective category shall be procured from same source.
- Insert design shall be as per recommendation & design of vendor. The insert geometry & grade should be suitable for smooth chip flow, chip breaking and productive machining.
- Vendor to ensure interchangeability of grooving inserts of same width among various tool holders in each category.
- The offer should be complete having list & quantity of each item offered with item wise price, technical details, tool drawings for special items & catalogue pages of standard items etc. for clear understanding of the offer. In case, vendor requires any clarification, they may discuss with BHEL prior to submission of their offer to avoid any gaps at later stage.
- All other dimensions/surfaces of Blade Groove except side groove portion of blade grooves shall be finished by BHEL, prior to trial machining of side groove portion of blade groove. Refer schematic drawings Fig-A and Fig-B of blade groove, showing hatched area (side groove portion) to be machined.

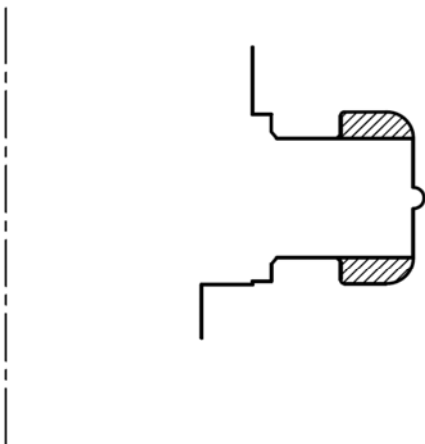

Fig - A

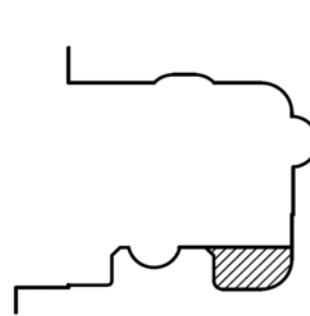
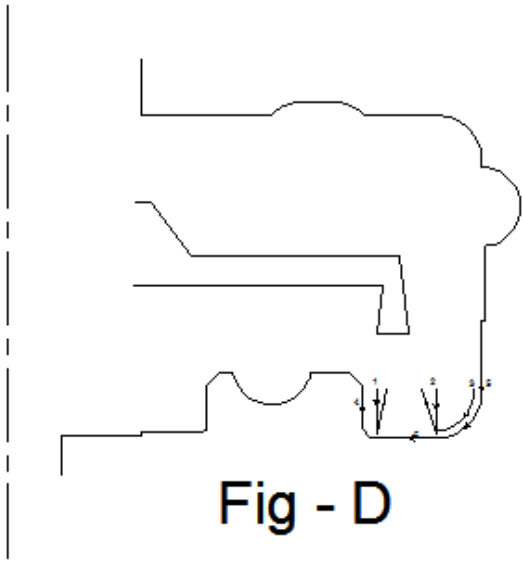
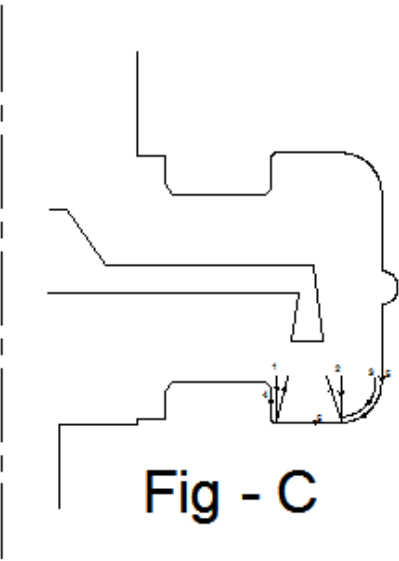

Fig - B



**ANNEXURE- 3**

**COMPLIANCE SHEET FOR TECHNICAL/COMMERCIAL TERMS AND CONDITIONS FOR THREE PART TENDER**

**PLEASE FILL THIS ANNEXURE & ATTACH WITH YOUR TECHNO-COMMERCIAL BID.**

You are requested to kindly confirm /clarify the following:-

| <b>S.No.</b> | <b>Description</b>  | <b>Your Confirmation</b> |
|--------------|---|--------------------------|
| 1.           | Vendor to confirm that they meet each & every clause of our Specifications/Drawings.  |                          |
| 2.           | If “No” to serial number 1, vendor to specify each deviated clause & submit in a separate sheet.  |                          |
| 3.           | Vendor to list out on a separate sheet any activity which is outsourced. Please furnish details of out sourced vendor.  |                          |
| 4.           | Validity: confirm that validity of the offer shall be 120 days from the date of tender opening  |                          |
| 5.           | Confirm that un-priced part of price bid is enclosed with technical commercial offer  |                          |
| 6.           | Confirm that prices have been quoted on FOB as well as C & F basis(For Foreign vendors);  |                          |
| 7.           | Confirm that Loading Port has been mentioned.   |                          |
| 8.           | Confirm that prices have been quoted on FOR BHEL Haridwar basis. (For Indigenous vendor)  |                          |
| 9.           | Confirm that prices shall be firm and fixed throughout delivery period.   |                          |
| 10.          | Confirm that payment shall be released after successful machining by any tool of each material code independently as per pt.no.8 of annexure-1.   |                          |
| 11.          | LD Penalty shall be applicable at the rate of ½ % (half percent) per week or part thereof subject to a maximum of 10% of the value of un executed portion of the order. In case of any variation in LD penalty, your prices shall be loaded to the extend LD penalty not accepted by you.   |                          |
| 12.          | Right of acceptance – BHEL reserves the right to reject any or all quotations without assigning any reasons thereof. BHEL also reserves the right to increase or decrease the tendered quantities. Vendors should be prepared to accept order for reduced quantities without any extra charges. Vendor should also be prepared for giving discount in case of increase in quantity. |                          |
| 13.          | Confirm specifically that material shall be supplied as per tender documents.   |                          |
| 14.          | Ink signed order acceptance shall be furnished within 15 days of order placement.   |                          |
| 15.          | PO.No.&/or vendors Emblem/seal shall be Clearly marked on each Item.  |                          |
| 16.          | The following documents shall be given while dispatching the goods.<br>1. Invoice<br>2. Packing List<br>3. GR/LR copy   |                          |
| 17.          | One copy of the above (Sl.No. 17) shall be sent directly to Sr. Manager (FAX-Store Bill)  |                          |
| 18.          | Delivery Schedule (Mention the schedule)  |                          |
| 19.          | Exact amount of CST/CVD/ED or % SHOULD BE CLEARLY MENTIONED   |                          |
| 20.          | The prices offered must be in your currency or in Rs and for Indian vendors- FOR – CPS, HEEP, BHEL Hardwar & for foreign vendors – FOB/FCA – nearest Port/Airport.  |                          |
| 21.          | For Foreign vendors: Confirm if there is any Indian agency commission included in your price. And if yes then indicate the percentage of the same.  |                          |

|   |  |              |             |
|---|--|--------------|-------------|
|  | ANNEXURE 4   | Document No. | AA:MM:SR:01 |
|   | <b>GUIDELINES TO FOREIGN SUPPLIERS<br/>FOR FILLING UP SUPPLIER<br/>REGISTRATION FORM</b> | Revision No. | 01          |
|   |  | Page No.     | I of II     |

1. Prospective Suppliers may also visit our web site [www.bhel.com](http://www.bhel.com) (link Supplier Registration -> New Supplier Required) to know more about the requirement of new suppliers for various items in our units.
2. Registration Form no. SRF(F)01 may be obtained from BHEL website [www.bhel.com](http://www.bhel.com).
3. Application for registration, with a covering letter detailing where your products can find application (if possible) in BHEL unit(s), should be sent to:

Supplier Development Cell

*Unit Name:*

Bharat Heavy Electricals Ltd.

*City:*

India

4. In case registration is being sought in multiple units of BHEL, please send the separate application to each unit.
5. Any clarification with respect to procedure for registration may be obtained from the Supplier Development Cell of respective BHEL unit.
6. All columns are to be filled up properly in the space provided for. Wherever it is not applicable, mention it as "Not Applicable". The form is to be signed by the authorised signatory and submitted in original.
7. Please attach separate sheet if the space provided is insufficient. For any other information also, separate sheet may be attached.
8. Any information / clarification required by BHEL during processing of registration must be given expeditiously.
9. Please ensure that all required enclosures are attached with the filled up Supplier Registration Form and all enclosures are numbered & list of enclosures is given as required.
10. As multiple copies of the application forms are required for processing at our end, please do not spiral bound the application forms or its enclosures and instead send them in two hole clip flat file.
11. Please fill up the check- list given on next page and send along with the Supplier Registration Forms to BHEL.
12. Please note that if you are registered and participate in Tender process and qualify to get order from BHEL, your performance based on Quality of your product, delivery performance and service rendered will be evaluated inline with Chapter VI.
13. If you are attaching a document in a language other than English, a self attested English translated document may please be also attached.

|   |   |              |             |
|---|---|--------------|-------------|
|  | <b>ANNEXURE 4</b>   | Document No. | AA:MM:SR:01 |
|   | <b>CHECK-LIST FOR FOREIGN<br/>SUPPLIERS REGISTRATION FORM</b> | Revision No. | 01          |
|   |   | Page No.     | II of II    |

| S.N. | Check-Point  | Yes/No |
|------|--|--------|
| 1.0  | Information against all points in the Supplier Registration Form has been given.                                   |        |
| 2.0  | Authorisation letter has been enclosed (in case of Indian representative)  |        |
| 3.0  | Banker's certificate has been enclosed   |        |
| 4.0  | Are you an ISO: 9001 accredited supplier?  |        |
| 4.1  | If yes, have you enclosed copy of ISO 9001 accreditation certificate & "Table of Contents" of your Quality Manual? |        |
| 4.2  | If no, have you enclosed written down procedure / manual of Quality Management System?                             |        |
| 5.0  | Have you enclosed experience list/ performance certificate ( as per sl. 3.0 of the form SRF(F) 01 )                |        |
| 6.0  | List of enclosures has been furnished ( as per Sl 5.0 of the form SRF(F) 01)                                       |        |
| 7.0  | All the parts of the form & enclosures have been signed by Authorised Signatory.                                   |        |
| 8.0  | D&B Report/ Creditreform report etc. has been attached.  |        |

Date :

Signature & seal

(Authorised Signatory)

Note : This check list is to be attached with the filled up Supplier Registration Form.



**BHARAT HEAVY ELECTRICALS LIMITED, INDIA**

**ANNEXURE 4**

**FORM NO. SRF(F)01 : (FOREIGN SUPPLIER)**

Page 2 of 2

- 1.8 YEAR OF COMMENCEMENT OF BUSINESS :
- 1.9 PRODUCTION CAPACITY PER ANNUM (details of major manufacturing/ testing facilities to be given) :
- 1.10 PARTICULARS OF PRODUCTS INCLUDING SPECIFICATION AND RANGE OFFERED FOR REGISTRATION : ( ATTACH BROCHURES AND CATALOGUES )
- 1.11 NAME (S) OF BANKERS :
- 1.12 BANKER'S CERTIFICATE AS TO CREDITWORTHINESS OF THE CLIENT (Enclose Certificate ) :
- 1.13 PORT OF LOADING :
- 1.14 NEAREST AIRPORT :
- 1.15 Report from D&B/ Creditreform etc. (As per Cl. 7.1 of Chapter V) (**MANDATORY**):

**2.0 FINANCIAL INFORMATION : (FOR LAST 3 YEARS)**

| PARAMETER        | YEAR -1 | YEAR -2 | YEAR -3 |
|------------------|---------|---------|---------|
| ANNUAL TURN OVER |         |         |         |
| PROFIT AFTER TAX |         |         |         |

( COPY OF AUDITED ANNUAL ACCOUNTS FOR LAST 3 YEARS TO BE ENCLOSED)

**3.0 QUALITY MANAGEMENT SYSTEM :**

- 3.1 IS THE COMPANY ISO:9001 CERTIFIED : YES / NO
- 3.1.1 IF YES, ENCLOSE COPY OF CERTIFICATE & TABLE OF CONTENTS OF QUALITY MANUAL.
- 3.1.2 IF NO, ENCLOSE QUALITY MANANGEMENT SYSTEM OR WRITTEN DOWN PROCEDURE

**4.0 EXPERIENCE LIST/ PERFORMANCE CERTIFICATE FOR OFFERED / SIMILAR ITEMS :**

(ATTACH LIST OF PRESENT CUSTOMERS WITH NAME & ADDRESS FOR OFFERED / SIMILAR TYPE & SIZE OF ITEM / EQUIPMENT FOR WHICH REGISTRATION HAS BEEN SOUGHT AND WITH WHOM YOU HAVE CONTINUOUS BUSINESS SINCE LAST THREE YEARS )

**5.0 ANY OTHER INFORMATION :**

**6.0 LIST OF ENCLOSURES :**  
(BROCHURES, CATALOGUES, TECHNICAL LITERATURE ETC.)

Signature & Seal

AUTHORISED SIGNATORY

E – Mail

NAME :

TELEPHONE : (Landline):  
Mobile :

DESIGNATION :

**DATE :**

|   |   |              |             |
|---|---|--------------|-------------|
|  | <b>ANNEXURE - 5</b>   | Document No. | AA:MM:SR:01 |
|   | <b>GUIDELINES TO INDIAN SUPPLIERS<br/>FOR FILLING-UP SUPPLIER<br/>REGISTRATION FORM</b> | Revision No. | 01          |
|   |   | Page No.     | I of II     |

1. Prospective Suppliers may also visit our web site [www.bhel.com](http://www.bhel.com) (link Supplier Registration -> New Supplier Required) to know more about the requirement of new suppliers for various items in our units.
2. Registration Form may be obtained from BHEL website [www.bhel.com](http://www.bhel.com).
3. Application for registration, with a covering letter detailing where your products can find application (if possible) in BHEL unit(s), should be sent to:

Supplier Development Cell  
*Unit Name:*  
 Bharat Heavy Electricals Ltd.  
*City:*  
 India

4. In case registration is being sought in multiple units of BHEL, please send the separate application to each unit.
5. Any clarification with respect to procedure for registration may be obtained from the Supplier Development Cell of respective BHEL unit.
6. The Supplier Registration Form has four parts:

|        |                                       |  |
|--------|---------------------------------------|--|
| Part A | Organisational Information            | Form no. SRF(I)01 – page 1 to 10               |
| Part B | Quality System                        | Form no. SRF(I)01 - page 11 to 12              |
| Part C | Technical Competence                  | Form no. SRF(I)01 page 13<br>(if sent by BHEL) |
| Part D | Score Sheet<br>(to be filled by BHEL) | Form no. SRF(I)01 page 14 to 17                |

The set of formats to be filled by different category of suppliers is as follows:

| Sl.No | Supplier Category  | Formats  |
|-------|--|--|
| 1.    | Indian Suppliers ( manufacturers )   | - Organisational Information<br>- Quality System<br>- Technical Competence                               |
| 2.    | Indian Stockist/ Trader/ Distributor/ Dealer/ Authorised Agent/ Channel partner/ Indian Sales office or Subsidiary of registered foreign principal | - Organisational Information SRF(I)01- Part A<br>(page 1 to 10 except Sl. No. 5.1, 5.2, 6.6, 6.7, 7 & 8) |

7. All columns are to be filled up properly in the space provided for. Wherever it is not applicable, please mention “Not Applicable”. The form is to be signed by the authorised signatory.
8. A separate sheet may be attached if the space provided is insufficient or additional information is to be given. Please put proper identification tag on the separately attached sheet.
9. Please ensure that all required enclosures are attached with the filled up Supplier Registration Form and all enclosures are numbered & list of enclosures is given as required.
10. As multiple copies of the application forms are required for processing at our end, please do not spiral bound the application forms or its enclosures and instead send them in two hole clip flat file.
11. Incomplete forms will be rejected.
12. Any information / clarification required by BHEL during evaluation must be given expeditiously.
13. Please note that if you are registered and participate in Tender process and qualify to get order from BHEL, your performance based on Quality of your product, delivery performance and service rendered will be evaluated inline with Chapter VI.
14. Please fill up the check- list given on next page and send along with the Supplier Registration Forms to BHEL.
15. If you are attaching a document in a language other than Hindi/ English, a self attested Hindi/ English translated document may please be also attached.

|   |   |              |             |
|---|---|--------------|-------------|
|  | <b>ANNEXURE - 5</b>   | Document No. | AA:MM:SR:01 |
|   | <b>Check List for Indian Supplier<br/>Registration Form</b> | Revision No. | 01          |
|   |   | Page No.     | II of II    |

| Sl.No. | Check-Point   | Yes/No |
|--------|---|--------|
| 1.     | Information against all points under “Organizational Information” (Part-A) has been given.  |        |
| 2.     | All enclosures and supporting documents have been enclosed.   |        |
| 3.     | Summary list of enclosures has been furnished as per S.N.10 of Organisational Information form no. SRF (I) 01 & S.N 12 of Quality system form no. SRF (I) 01. |        |
| 4.     | Are you an ISO 9001 accredited supplier?  |        |
| 5.     | If yes, have you enclosed "Table of Contents" of your Quality Manual and copy of ISO 9001 accreditation certificate?  |        |
| 6.     | Have you filled up Quality System format given in Part B?   |        |
| 7.     | Technical requirements, specifications, drawings, standards have been received from BHEL before filling up Technical Competence, Part C.                      |        |
| 8.     | All the parts of the form & enclosures have been signed by Authorised Signatory.  |        |
| 9.     | Have you attached EFT details? (In original, Certified by the bank)   |        |
| 10.    | If you are seeking registration for a MSME company (as per MSME Act of Government of India), have you attached requisite certificate as per Act?              |        |

Date :

Signature & seal

(Authorised Signatory)

Note: This check list is to be attached with the filled up Supplier Registration Form.

**BHARAT HEAVY ELECTRICALS LIMITED  
SUPPLIER REGISTRATION FORM**

FORM NO. SRF(I) 01 (INDIAN SUPPLIER)

ANNEXURE - 5

Page 1 of 17

INFORMATION WITH \* MARKS IS SCOREABLE.

**PART- A : ORGANISATIONAL SOUNDNESS**

ALL COLUMNS SHOULD BE PROPERLY FILLED IN THE SPACE PROVIDED FOR, WHEREVER IT IS NOT APPLICABLE, PLEASE WRITE "NOT APPLICABLE". INCOMPLETE OR INCORRECT FORMS MAY NOT BE CONSIDERED. PLEASE ATTACH SEPARATE SHEET, IF SPACE AVAILABLE IS INADEQUATE.

ALL THE PAGES OF THE FORM ARE TO BE SIGNED ALONGWITH SEAL BY THE AUTHORISED SIGNATORY

| ORGANISATIONAL INFORMATION   |             |                         |                                |
|--|-------------|-------------------------|--------------------------------|
| <b>NAME AND CORRESPONDENCE ADDRESS OF THE SUPPLIER<br/>SEEKING REGISTRATION :-</b>   |             |                         |                                |
| <b>1.0 PRODUCTS / SYSTEMS / SERVICES FOR WHICH REGISTRATION IS<br/>APPLIED FOR :</b> |             |                         |                                |
| SL.<br>NO.   | DESCRIPTION | SIZE & RANGE            | MFG. STD/ IS / DIN /BS<br>ETC. |
|  |             |                         |                                |
| SUPPLIER'S AUTHORISED SIGNATORY  |             | BHEL CERTIFIED ASSESSOR |                                |

**BHARAT HEAVY ELECTRICALS LIMITED  
SUPPLIER REGISTRATION FORM**

**FORM NO. SRF(I) 01 (INDIAN SUPPLIER)**

**ANNEXURE - 5**

Page 2 of 17

**ORGANISATIONAL INFORMATION**

**2.0 GENERAL INFORMATION :**

2.1 NAMES OF THE WORKS/DIVISION (Products manufactured at each works to be mentioned :

ADDRESS : E - Mail :

TELEPHONE : Landline

Mobile

FAX :

2.2 NAME OF CHIEF EXECUTIVE /  
PROPRIETOR / PARTNER & ADDRESS :

2.3 DETAILS OF AUTHORISED SIGNATORY FOR SEEKING CLARIFICATION :

NAME :

DESIGNATION : E - Mail

:

TELEPHONE : Landline

Mobile

FAX :

SUPPLIER'S AUTHORISED SIGNATORY

BHEL CERTIFIED ASSESSOR

**BHARAT HEAVY ELECTRICALS LIMITED  
SUPPLIER REGISTRATION FORM**

**FORM NO. SRF(I) 01 (INDIAN SUPPLIER)**

**ANNEXURE - 5**

Page 3 of 17

**ORGANISATIONAL INFORMATION**

**3.0 OWNERSHIP INFORMATION :** DOCUMENTS TO BE FURNISHED

3.1 GOVT. OF INDIA UNDERTAKING:

OR

STATE GOVT. UNDERTAKING :

OR

LIMITED COMPANY, :

MEMORANDUM AND  
ARTICLES OF ASSOCIATION

OR

PRIVATE COMPANY :

MEMORANDUM AND  
ARTICLES OF ASSOCIATION

OR

CO-OPERATIVE SOCIETY, :

SOCIETY RULES AND  
BYE LAWS

OR

PARTNERSHIP FIRM, :

PARTNERSHIP DEED

OR

PROPRIETORSHIP, :

PROFESSION TAX REGN.  
AND MUNICIPAL REGN.

ANY OTHER (SPECIFY) :

3.2 NATURE OF BUSINESS :

(MANUFACTURING UNIT/  
ENGG CONSULTANT/ EPC CONTRACTOR)

(AGENTS/ DISTRIBUTORS/STOCKISTS/DEALERS/  
TRADERS/ INDIAN SUBSIDIARY/ CHANNEL PARTNER – attach authorization  
certificate of principal)

3.3 YEAR OF ESTABLISHMENT :

\* 3.4 YEAR OF COMMENCEMENT OF BUSINESS :

SUPPLIER'S AUTHORISED SIGNATORY

BHEL CERTIFIED ASSESSOR

**BHARAT HEAVY ELECTRICALS LIMITED  
SUPPLIER REGISTRATION FORM**

**FORM NO. SRF(I) 01 (INDIAN SUPPLIER)**

**ANNEXURE - 5**

Page 4 of 17

**ORGANISATIONAL INFORMATION**

**4.0 REGISTRATION PARTICULARS**

( FURNISH DETAILS AND ENCLOSE COPY OF CERTIFICATE FOR THE FOLLOWING)

- 4.1 PERMANENT ACCOUNT NO :  
4.2 CENTRAL SALES TAX REGN NUMBER :  
4.3 STATE SALES TAX / TIN NUMBER :  
4.4 EXCISE DUTY REGN NUMBER :  
4.5 EXCISE CONTROL CODE NUMBER :  
4.6 SERVICE TAX REGN NUMBER :  
4.7 CATEGORY AS PER MSMED ACT : MICRO/ SMALL/ MEDIUM  
REGN NO. :  
VALID UPTO :  
(Attach Certificate)

**5.0 TOTAL ORGANISATIONAL STRENGTH : (ATTACH ORGANISATION CHART)**

- |  | GRADUATE | DIPLOMA | SKILLED | NON-SKILLED |
|--|----------|---------|---------|-------------|
| ENGINEERING :                                      |          |         |         |             |
| MANUFACTURING :                                    |          |         |         |             |
| QUALITY :  |          |         |         |             |
| COMMERCIAL /<br>SERVICE AFTER SALES :              |          |         |         |             |
| OTHERS :   |          |         |         |             |
| TOTAL :  |          |         |         |             |
| * 5.1 POWER BACKUP :<br>(GIVE DETAILS)             | YES/ NO  |         |         |             |
| * 5.2 DOES THE COMPANY SELL ITS PRODUCT DIRECTLY : | YES/ NO  |         |         |             |

SUPPLIER'S AUTHORISED SIGNATORY

BHEL CERTIFIED ASSESSOR

**BHARAT HEAVY ELECTRICALS LIMITED  
SUPPLIER REGISTRATION FORM**

FORM NO. SRF(I) 01 (INDIAN SUPPLIER)

ANNEXURE - 5

Page 5 of 17

**ORGANISATIONAL INFORMATION**

**6.0 OTHER PARTICULARS :**

( FURNISH DETAILS AND ENCLOSE DOCUMENTARY EVIDENCE/ COPY OF CERTIFICATE FOR THE FOLLOWING)

\* 6.1 IF THE COMPANY IS ALREADY REGISTERED WITH ANY OF BHEL UNITS, GIVE :

6.1.1. BHEL UNIT'S NAME :

6.1.2. SUPPLIER REGN. CODE NO. :

6.1.3. ITEMS FOR WHICH REGISTERED & THEIR SPECIFICATION  
( ENCLOSE PROOF OF SUCCESSFUL EXECUTION OF  
ONE OR MORE PURCHASE ORDERS ):

\* 6.2 IS THE COMPANY APPROVED BY  
ASME / NTPC / NPC / EIL / DGS&D / RAILWAYS /  
IBR / LLOYDS ETC FOR INTENDED  
MATERIAL CATEGORY? : YES / NO  
(ENCLOSE DOCUMENTARY EVIDENCE)

\* 6.3 IS THE COMPANY ISO 9001 APPROVED? : YES / NO  
(ENCLOSE CERTIFICATE & TOC OF QUALITY SYSTEM) :

\* 6.4 IS THE COMPANY AN ISO 14000 APPROVED? : YES / NO  
(ENCLOSE CERTIFICATE) :

\* 6.5 IS THE COMPANY OHSAS - 18000 APPROVED?: YES / NO  
(ENCLOSE CERTIFICATE)

\* 6.6 TECHNICAL COLLABORATOR :  
(FOREIGN OR INDIGENOUS)  
(ENCLOSE DOCUMENTARY EVIDENCE)

\* 6.7 R&D SET UP

6.8 DIRECTORS / PARTNERS, IF RELATED TO ANY  
BHEL EMPLOYEE.

NAME :

STAFE NO. :

DESIGNATION :

Unit & DEPARTMENT :

RELATIONSHIP :

SUPPLIER'S AUTHORISED SIGNATORY

BHEL CERTIFIED ASSESSOR

**BHARAT HEAVY ELECTRICALS LIMITED  
SUPPLIER REGISTRATION FORM**

**FORM NO. SRF(I) 01 (INDIAN SUPPLIER)**

**ANNEXURE - 5**

Page 6 of 17

**ORGANISATIONAL INFORMATION**

6.9 IF ANY EX-BHEL PERSONNEL IS EMPLOYED BY THE COMPANY, MENTION HIS / HER DETAILS OF LAST POSTING.

NAME :  
STAFF NO. :  
DESIGNATION :  
UNIT & DEPARTMENT :  
DATE OF LEAVING SERVICE :

6.10 COMPANY'S WEEKLY HOLIDAYS :

WORKS                      OFFICE

6.11 EXPERIENCE LIST:

(ATTACH LIST OF PRESENT CUSTOMERS WITH NAME & ADDRESS FOR OFFERED / SIMILAR TYPE & SIZE OF ITEM / EQUIPMENT FOR WHICH REGISTRATION HAS BEEN SOUGHT AND WITH WHOM YOU HAVE CONTINUOUS BUSINESS SINCE LAST THREE YEARS . ALSO ATTACH PERFORMANCE CERTIFICATES ISSUED BY ANY TWO CLIENTS FOR SUCCESSFUL EXECUTION OF THE CONTRACTS FOR LAST TWO YEARS- FOR PEM)

\*6.12 DETAILS OF PENDING LEGAL ISSUES ON CONTRACTUAL ASPECTS WITH CUSTOMER , IF ANY

6.13 The following information of Bank Account of the Company, duly endorsed by the Bank (required for Electronic Fund Transfer –EFT/RTGS) is to be submitted

1. Name of the Company
2. Name of Bank
3. Name of Bank Branch
4. City/Place
5. Account Number
6. Account type
7. IFSC code of the Bank Branch
8. MICR Code of the Bank Branch
9. Details of other Bankers (for reference purpose only)

NOTE :

(i) Suppliers who have already submitted the above information are requested to submit a copy of the same.

SUPPLIER'S AUTHORISED SIGNATORY

BHEL CERTIFIED ASSESSOR

**BHARAT HEAVY ELECTRICALS LIMITED  
SUPPLIER REGISTRATION FORM**

FORM NO. SRF(I) 01 (INDIAN SUPPLIER)

ANNEXURE - 5

Page 7 of 17

**ORGANISATIONAL INFORMATION**

**7.0 MANUFACTURING FACILITIES:**

**\*7.1 LIST OF MANUFACTURING FACILITIES/EQUIPMENTS (INCLUDING MATERIAL HANDLING FACILITY)**

| SL. NO | DESCRIPTION OF MACHINE/EQUIPMENT | QUANTITY | MAKE & YEAR OF INSTALLATION | REMARKS |
|--------|----------------------------------|----------|-----------------------------|---------|
|        |                                  |          |                             |         |
|        |                                  |          |                             |         |
|        |                                  |          |                             |         |
|        |                                  |          |                             |         |

IN CASE OF SPACE LIMITATION, PLEASE ENCLOSE ANNEXURE / CATALOGUE WITH TAG

**\* 7.2 IF IN-HOUSE MFG FACILITIES NOT AVAILABLE, INFORM SOURCE OF MFG. DETAILS ALONGWITH THEIR FACILITIES & EXPERIENCE**

| SL. NO | PROCESS OUTSOURCED | NAME OF THE COMPANY | DESCRIPTION OF MACHINE / EQUIPMENT | REMARKS |
|--------|--------------------|---------------------|------------------------------------|---------|
|        |                    |                     |                                    |         |
|        |                    |                     |                                    |         |
|        |                    |                     |                                    |         |
|        |                    |                     |                                    |         |
|        |                    |                     |                                    |         |

IN CASE OF SPACE LIMITATION ENCLOSE ANNEXURE / CATALOGUE WITH TAG

**\* 7.3 RATIO OF OUTSOURCED COST TO TOTAL PRODUCTION VALUE:**

SUPPLIER'S AUTHORISED SIGNATORY

BHEL CERTIFIED ASSESSOR

**BHARAT HEAVY ELECTRICALS LIMITED  
SUPPLIER REGISTRATION FORM**

FORM NO. SRF(I) 01 (INDIAN SUPPLIER)

ANNEXURE - 5

Page 8 of 17

|                                   |
|-----------------------------------|
| <b>ORGANISATIONAL INFORMATION</b> |
|-----------------------------------|

**8.0 INSPECTION & TESTING FACILITIES:**

**\* 8.1 LIST OF INSPECTION & TESTING FACILITIES / EQUIPMENT**

| SL. NO | DESCRIPTION OF FACILITY/ EQUIPMENT & CAPACITY | NOS. | MAKE & YEAR OF MANUFACTURING | LAST DATE OF CALIBERATION |
|--------|---|------|------------------------------|---------------------------|
|        |   |      |                              |                           |
|        |   |      |                              |                           |
|        |   |      |                              |                           |
|        |   |      |                              |                           |
|        |   |      |                              |                           |
|        |   |      |                              |                           |
|        |   |      |                              |                           |
|        |   |      |                              |                           |

IN CASE OF SPACE LIMITATION ENCLOSE ANNEXURE / CATALOGUE WITH TAG

**\* 8.2 IF IN-HOUSE TESTING FACILITIES NOT AVAILABLE, INDICATE SOURCE OF TESTING ALONGWITH THEIR FACILITIES & EXPERIENCE**

| SL. NO | TEST | SOURCE OF TESTING | DESCRIPTION OF FACILITY/ EQUIPMENT & CAPACITY | APPROVAL OF EQUIPMENT/ PROCESS/PERSONNEL QUALIFICATION |
|--------|------|-------------------|---|--|
|        |      |                   |   |  |
|        |      |                   |   |  |
|        |      |                   |   |  |
|        |      |                   |   |  |
|        |      |                   |   |  |

IN CASE OF SPACE LIMITATION ENCLOSE ANNEXURE / CATALOGUE WITH TAG

**Note:**

**In case of outsourcing of major testing such as NDT, Electrical & Mechanical Testing, no marks will be awarded. However, material composition testing by chemical method from recognized laboratory shall not attract negative marking**

|                                 |                         |
|---------------------------------|-------------------------|
| SUPPLIER'S AUTHORISED SIGNATORY | BHEL CERTIFIED ASSESSOR |
|---------------------------------|-------------------------|

**BHARAT HEAVY ELECTRICALS LIMITED  
SUPPLIER REGISTRATION FORM**

FORM NO. SRF(I) 01 (INDIAN SUPPLIER)

ANNEXURE - 5

Page 9 of 17

| ORGANISATIONAL INFORMATION   |   |   |                         |        |          |
|--|---|---|-------------------------|--------|----------|
| FINANCIAL INFORMATION FOR THE PREVIOUS FOUR YEARS  |   |   |                         |        |          |
| 9.0  | Parameter   | Year 1  | Year 2                  | Year 3 | Year 4   |
|  |   | (Years in ascending order, Money value in Rs. Lakhs ) |                         |        |          |
| * 9.1  | NET WORTH (Share Capital +Reserves)   |   |                         |        |          |
|  | Growth over previous year (%)   | -----   |                         |        |          |
| 9.2  | LONG TERM DEBT / LOAN   |   |                         |        |          |
| * 9.3  | DEBT EQUITY RATIO<br><u>Long term Debt (9.2)</u><br><u>Net worth (9.1)</u>                                |   |                         |        |          |
| 9.4  | INVESTMENT IN:<br>Land & Building   |   |                         |        |          |
|  | Plant & Machinery   |   |                         |        |          |
|  | Other Fixed Assets  |   |                         |        |          |
| 9.5*   | NET CURRENT ASSETS  |   |                         |        |          |
|  | 1 a) Cash on hand   |   |                         |        |          |
|  | b) Account receivable   |   |                         |        |          |
|  | c) Inventories  |   |                         |        |          |
|  | Total   |   |                         |        |          |
|  | CURRENT LIABILITY   |   |                         |        |          |
|  | 2 a) Sundry creditors   |   |                         |        |          |
|  | b) Interest accrued but not due   |   |                         |        |          |
|  | c) Other liabilities  |   |                         |        |          |
|  | Total   |   |                         |        |          |
| * 3  | * QUICK RATIO<br><u>CA - INVENT. {9.5(1)-9.5(1)c}</u><br><u>Current liability {9.5 (2)}</u>               |   |                         |        |          |
| * 9.6  | SALES   |   |                         |        |          |
|  | Growth over previous year (%)   | -----   |                         |        |          |
| * 9.7  | PROFIT BEFORE TAX   |   |                         |        |          |
|  | Growth over previous year (%)   | -----   |                         |        |          |
| * 9.8  | Whether the supplier has been referred to BIFR / NCLT / any other Govt agency ( If YES , enclose details) |   |                         |        | YES / NO |
| * 9.9  | Whether the supplier is a potential sick company.( If YES , enclose details)                              |   |                         |        | YES / NO |
| NOTE: 1. Copies of annual accounts (Balance Sheet) for the last four years (or from date of incorporation which ever is less) along with audit report are to be submitted. The above details shall be highlighted in the Balance Sheet.<br>2. Status of Tax assessments done under various laws (Income Tax, VAT/Sales Tax, Excise & Service Tax, Custom) and details of disputes pending, if any, with these authorities to be submitted. |   |   |                         |        |          |
| SUPPLIER'S AUTHORISED SIGNATORY  |   |   | BHEL CERTIFIED ASSESSOR |        |          |

**BHARAT HEAVY ELECTRICALS LIMITED  
SUPPLIER REGISTRATION FORM**

**FORM NO. SRF(I) 01 (INDIAN SUPPLIER)**

**ANNEXURE - 5**

Page 10 of 17

|                                   |
|-----------------------------------|
| <b>ORGANISATIONAL INFORMATION</b> |
|-----------------------------------|

**10. LIST OF ENCLOSURES** (Tags to be put on enclosures) :

- (i) MEMORANDUM AND ARTICLES OF ASSOCIATION / SOCIETY RULES AND BYE LAWS / PARTNERSHIP DEED/ PROFESSION TAX REGN & MUNICIPAL REGN. : YES / NO
- (ii) Copy of certificate of following:-
  - x PERMANENT ACCOUNT NO : YES / NO
  - x CENTRAL SALES TAX REGN NUMBER : YES / NO
  - x STATE SALES TAX / TIN NUMBER : YES / NO
  - x EXCISE DUTY REGN NUMBER : YES / NO
  - x EXCISE CONTROL CODE NUMBER : YES / NO
  - x SERVICE TAX REGN NUMBER : YES / NO
  - x REGN NUMBER OF CATEGORY AS PER MSMED ACT : YES / NO
- (iii) ORGANISATION CHART : YES / NO
- (iv) If registered with any other BHEL Unit,
  - x LETTER OF REGISTRATION WITH BHEL UNIT : YES / NO
  - x PROOF OF SUCCESSFUL EXECUTION OF ONE OR MORE PURCHASE ORDERS : YES / NO
- (v) Letter of approval from ASME / NTPC / NPC / EIL / DGS&D / RAILWAYS /IBR / LLOYDS ETC : YES / NO
- (vi) Accreditation certificate for
  - x ISO: 9001 : YES / NO
  - x TOC of Quality System Manual : YES / NO
  - x ISO : 14000 : YES / NO
  - x OHSAS , ISO 18000 : YES / NO
- (vii) Letter regarding technical collaboration : YES / NO
- (viii) Experience List / Performance certificate : YES / NO
- (ix) Balance Sheet for the last four years along with audit Report : YES / NO
- (x) Principal's authorization in case of dealers/ agents : YES / NO
- (xi) EFT Bank's certificate : YES / NO

I /WE GIVE THE UNDERTAKING THAT BHEL DRAWINGS & SPECIFICATIONs SHALL NOT BE USED IN ANY WAY DETRIMENTAL TO THE INTEREST OF BHEL AND/ OR FOR SUPPLY OF ANY MATERIAL, PRODUCT OR SERVICES DIRECTLY OR INDIRECTLY TO ANY OTHER CUSTOMER.

Maximum Marks = 50  
Negative Marks = -13  
Minimum Qualifying marks = 30

|  |
|--|
|  |
|--|

**BHARAT HEAVY ELECTRICALS LIMITED  
SUPPLIER REGISTRATION FORM**

**FORM NO. SRF(I) 01 (INDIAN SUPPLIER)**

**ANNEXURE - 5**

Page 11 of 17

**FORM NO. SRF(I) 01**

**Part B (QUALITY SYSTEM):**

| Sl. No | PARAMETERS   | SYSTEM IN EFFECT<br>(Tick if exists & provide evidences if ticked in written procedure) |          | RECORDS<br>(Tick if available & submit evidences) | REMARKS   |
|--------|--|---|----------|---|---|
|        |  | Written Procedure   | Practice |   |   |
| 1*     | Incoming Material Control System   |   |          |   | Furnish a copy of system and organization.                                  |
| 2*     | In process control   |   |          |   | Furnish at least one work instruction & record of process control parameter |
| 3*     | Manufacturing / Testing Procedure Qualification  |   |          |   | Procedure Qualification specification may be submitted                      |
| 4*     | Personnel qualification for 3 above.   |   |          |   | Record of Personnel qualification (PQR) to be submitted                     |
| 5*     | Calibration system   |   |          |   | Submit list of instrument & their calibration status                        |
| 6*     | System of Identification & Traceability of materials, tools, jigs, fixtures & processed components, etc. |   |          |   | Copy of procedure to be submitted   |
| 7*     | System of Storage, Preservation , Painting & packing   |   |          |   | Copy of procedure to be submitted   |
| 8*     | System of NCR disposition & corrective preventive action   |   |          |   | Two copies of NCR & CAPA  |
| 9*     | Customer complaints handling system  |   |          |   | Submit list of customer complaints & status for the last three years        |
| 10*    | Safety measures  |   |          |   | Submit copy of safety system & Record of accidents for last three years     |
| 11     | Any other quality initiative   |   |          |   |   |

SUPPLIER'S AUTHORISED SIGNATORY

BHEL CERTIFIED ASSESSOR

**BHARAT HEAVY ELECTRICALS LIMITED  
SUPPLIER REGISTRATION FORM**

**FORM NO. SRF(I) 01 (INDIAN SUPPLIER)**

**ANNEXURE - 5**

Page 12 of 17

**FORM NO. SRF(I) 01**

**Part B (QUALITY SYSTEM):**

**12. LIST OF ENCLOSURES**

- (i) Copy of system of control incoming materials and organization chart
- (ii) Copy of at least one process control work instruction
- (iii) Record of process control parameter
- (iv) Copy of at least one Procedure Qualification specification
- (v) Record of Personnel qualification (PQR)
- (vi) List of instrument & their calibration status
- (vii) Copy of procedure for Identification & Traceability of materials, tools, jigs, fixtures & processed components, etc.
- (viii) Copy of procedure for Storage/ preservation/ painting & packing
- (ix) Copies of two NCRs and their CAPA.
- (x) List of customer complaints & status for the last three years
- (xi) Copy of safety system
- (xii) Record of accidents for last three years

Maximum Marks = 25

Minimum Qualifying marks = 15

SUPPLIER'S AUTHORISED SIGNATORY

BHEL CERTIFIED ASSESSOR

**BHARAT HEAVY ELECTRICALS LIMITED  
SUPPLIER REGISTRATION FORM**

FORM NO. SRF(I) 01 (INDIAN SUPPLIER)

ANNEXURE - 5

Page 13 of 17

**FORM NO. SRF(I)01**

**Part C : TECHNICAL COMPETENCE**

Technical competence shall be evaluated in two parts viz. common competence and product/material category specific competence.

**(i) COMMON TECHNICAL COMPETENCE (Max Marks: 10)**

| <b>TECHNICAL COMPETENCE</b><br>( where <b>design specification</b> is given by BHEL )            | <b>MARKING RANGE</b> | SUPPLIER RESPONSE (ALONG WITH SUPPORTING DOCUMENTS)# | MARKS BY BHEL |
|--|----------------------|--|---------------|
| 1. Supplier understands the product specification.   | <b>(0-3)</b>         |  |               |
| 2. Supplier understands the inspection requirements.   | <b>(0-2)</b>         |  |               |
| 3. Supplier has process capability to achieve the product specification/dimensional requirement. | <b>(0-3)</b>         |  |               |
| 4. Supplier has experienced manpower to carry out the job.                                       | <b>(0-2)</b>         |  |               |
| <b>TOTAL MARKS OUT OF POSSIBLE (10) = ---</b>  |                      |  |               |

**OR**

| <b>TECHNICAL COMPETENCE</b><br>( where <b>performance specification</b> is given by BHEL ) | <b>MARKING RANGE</b> | PROCEDURE  |               | SYSTEM IN EFFECT                                     |               | RECORDS  |               |
|--|----------------------|--|---------------|--|---------------|--|---------------|
|  |                      | SUPPLIER RESPONSE (ALONG WITH SUPPORTING DOCUMENTS)# | MARKS BY BHEL | SUPPLIER RESPONSE (ALONG WITH SUPPORTING DOCUMENTS)# | MARKS BY BHEL | SUPPLIER RESPONSE (ALONG WITH SUPPORTING DOCUMENTS)# | MARKS BY BHEL |
| 1. Design capability   | <b>(0-3)</b>         |  |               |  |               |  |               |
| 2. Adequacy of quality assurance plan  | <b>(0-2)</b>         |  |               |  |               |  |               |
| 3. Process capability for components   | <b>(0-3)</b>         |  |               |  |               |  |               |
| 4. Adequate of testing   | <b>(0-2)</b>         |  |               |  |               |  |               |
| <b>TOTAL MARKS OUT OF POSSIBLE (10)</b>  |                      |  |               |  |               |  |               |
| <b>Average of Total (Total/3) = -----</b>  |                      |  |               |  |               |  |               |

**(ii) PROUCT/ MATERIAL CATEGORY SPECIFIC TECHNICAL COMPETENCE**

**(Max Marks: 15)**

Unit MISCC to structure the parameters to be considered for the technical competence depending on material category. The score of individual parameter selected is to be decided by MISCC. MISCC shall identify the requirement of enclosures to be furnished by supplier

Product:

| Sl. No | Material category | Tech Parameter | Supplier's response | Remarks |
|--------|-------------------|----------------|---------------------|---------|
|        |                   |                |                     |         |
|        |                   |                |                     |         |

To be filled up only on receipt of technical requirements/ specification, drawings, standards from BHEL and to be sent to BHEL for further scrutiny. Enclose documentary evidence where ever required.

**LIST OF ENCLOSURES:**

Maximum Marks = 25

Minimum Qualifying marks = 15

# No marks is to be given by the supplier. Only supplier response along with supporting documents,

|                                 |                         |
|---------------------------------|-------------------------|
| SUPPLIER'S AUTHORISED SIGNATORY | BHEL CERTIFIED ASSESSOR |
|---------------------------------|-------------------------|

# BHARAT HEAVY ELECTRICALS LIMITED SUPPLIER REGISTRATION FORM

FORM NO. SRF(I) 01 (INDIAN SUPPLIER)

ANNEXURE - 5

Page 14 of 17

## **Part D : SCORE SHEET**

### **1. ORGANISATIONAL SOUNDNESS (for Manufacturers):**

| S.N. | PARAMETER   | CRITERIA   | Maxm. Marks | Marks Awarded |
|------|---|--|-------------|---------------|
| 1.   | Whether all <b>relevant information</b> like ownership, PAN no., sales tax no., excise duty no., etc. submitted | Yes: 2<br>No: 0  | 2           |               |
| 2.   | 3.4 YEAR OF COMMENCEMENT OF BUSINESS  | More than 5 years : 2<br>1-5 years : 1<br>Less than 1 year : 0 | 2           |               |
| 3.   | 5.1 POWER BACKUP  | Yes : 1<br>No : 0  | 1           |               |
| 4.   | 5.2 DOES THE COMPANY SELL ITS PRODUCT DIRECTLY  | Yes : 1<br>No : 0  | 1           |               |
| 5.   | 6.1 REGISTERED WITH ANY OF BHEL UNITS   | Yes (same item) : 2<br>Yes (another item) : 1<br>No : 0        | 2           |               |
| 6.   | 6.2 APPROVAL BY ASME/ NTPC/ NPC/ EIL/ DGS&D/ RAILWAYS/ IBR/ LLOYDS ETC  | Yes : 2<br>No : 0  | 2           |               |
| 7.   | 6.3 ISO 9001 ACCREDITATION  | Yes : 3<br>No : 0  | 3           |               |
| 8.   | 6.4 ISO 14000 ACCREDITATION   | Yes : 1<br>No : 0  | 1           |               |
| 9.   | 6.5 OHSAS - 18000 ACCREDITATION   | Yes : 1<br>No : 0  | 1           |               |
| 10.  | 6.6 TECHNICAL COLLABORATOR : (FOREIGN OR INDIGENOUS)  | Yes : 1<br>No : 0  | 1           |               |
| 11.  | 6.7 R & D SET UP  | Yes : 1<br>No : 0  | 1           |               |
| 12.  | 6.12 PENDING LEGAL ISSUES ON TECHNO – COMMERCIAL ASPECTS WITH CUSTOMER  | Yes : -5<br>No : 0   | 0           |               |
| 13.  | 7.1 & 7.2 MANUFACTURING FACILITIES INCLUDING OUTSOURCING  | Adequate : 3<br>Substantial : 2<br>Inadequate : 0              | 3           |               |
| 14.  | 7.3 RATIO OF OUTSOURCED COST TO TOTAL PRODUCTION VALUE  | Less than 10% : 2<br>10 to 30 % : 1<br>More than 30% : 0       | 2           |               |
| 15.  | 8.1 INSPECTION & TESTING FACILITIES   | Adequate : 2<br>Substantial : 1<br>Inadequate : 0              | 2           |               |
| 16.  | 8.2 OUTSOURCING OF MAJOR TESTING FACILITY (Refer Note)  | Yes : 0<br>No : 1  | 1           |               |
|      | <b>TOTAL</b>  |  | <b>25</b>   |               |

### **1. ORGANISATIONAL SOUNDNESS (for Indian Stockist/ Trader/ Distributor/ Dealer/ Authorised Agent/ Channel partner/ Indian Sales office or Subsidiary of registered foreign principal):**

| S.N. | PARAMETER   | CRITERIA   | Maxm. Marks | Marks Awarded |
|------|---|--|-------------|---------------|
| 1.   | Whether all <b>relevant information</b> like ownership, PAN no., sales tax no., etc. submitted ( <b>clause 6.0 of chapter V to be referred in this regard</b> ) | Yes: 7<br>No: 0  | 7           |               |
| 2.   | 3.4 YEAR OF COMMENCEMENT OF BUSINESS  | More than 3 years : 2<br>1-3 years : 1<br>Less than 1 year : 0 | 2           |               |
| 3.   | 6.1 REGISTERED WITH ANY OF BHEL UNITS   | Yes (same item) : 2<br>Yes (another item) : 1<br>No : 0        | 2           |               |
| 4.   | 6.2 APPROVAL BY ASME/ NTPC/ NPC/ EIL/ DGS&D/ RAILWAYS/ IBR/ LLOYDS ETC  | Yes : 2<br>No : 0  | 2           |               |
| 5.   | 6.3 ISO 9001 ACCREDITATION  | Yes : 2<br>No : 0  | 2           |               |
| 6.   | 6.12 PENDING LEGAL ISSUES ON TECHNO – COMMERCIAL ASPECTS WITH CUSTOMER  | Yes : -5<br>No : 0   | 0           |               |

**BHEL CERTIFIED ASSESSOR**

**BHARAT HEAVY ELECTRICALS LIMITED  
SUPPLIER REGISTRATION FORM**

FORM NO. SRF(I) 01 (INDIAN SUPPLIER)

ANNEXURE - 5

Page 15 of 17

**Part D: SCORE SHEET**

**2. FINANCIAL INFORMATION (for Manufacturers):**

| S.N.         | PARAMETER  | CRITERIA   | Maximum Marks | Marks Awarded |
|--------------|--|--|---------------|---------------|
| 1.           | 9.1 Growth of Net Worth over previous year (%)<br>Average of three years to be worked out  | More than 20 % : 5<br>10 – 20 % : 4<br>5 – 10 % : 3<br>> 0 & < 5 % : 2<br>0 or below : 0                   | 5             |               |
| 2.           | 9.3 DEBT EQUITY RATIO<br><u>Long term Debt (9.2)</u><br>Net worth (9.1)                    | 1 : 1 : 5<br>1.1 upto 1.5 : 1 : 4<br>1.6 upto 2.0 : 1 : 3<br>2.0 & above : 1 : 2                           | 5             |               |
| 3.           | 9.5 QUICK RATIO<br><u>CA - INVENTORIES {9.5(1)-9.5(1)c}</u><br>Current liability {9.5 (2)} | 1 : 1 : 5<br>1 : 1 upto 1.5 : 4<br>1 : 1.5 upto 1.75 : 3<br>1 : 1.75 upto 2.5 : 2<br>1 : > 2.5 : 0         | 5             |               |
| 4.           | 9.6 Growth in Sales over previous year (%)<br>Average of three years to be worked out      | More than 35% : 5<br>20 -35 % : 4<br>10 – 20 % : 3<br>5 – 10 % : 2<br>> 0 & < 5 % : 1<br>0 or negative : 0 | 5             |               |
| 5.           | 9.7 PROFIT BEFORE TAX<br><br>Growth over previous year (%)                                 | More than 20 % : 5<br>10 – 20 % : 4<br>5 – 10 % : 3<br>> 0 & < 5 % : 2<br>0 or below : 0                   | 5             |               |
| 6.           | 9.8 Whether the supplier has been referred to BIFR / NCLT/ any other similar Govt agency   | Yes: -5<br>No : 0  | 0             |               |
| 7.           | 9.9 Whether the supplier is a potentially sick company                                     | Yes: -3<br>No : 0  | 0             |               |
| <b>TOTAL</b> |  |  | <b>25</b>     |               |

Note: If the supplier is new in business and does not have past data, then the evaluation will be done on the basis of information provided by him and will be decided by MISCC.

**2. FINANCIAL INFORMATION (for Indian Stockist/ Trader/ Distributor/ Dealer/ Authorised Agent/ Channel partner/ Indian Sales office or Subsidiary of registered foreign principal):**

| S.N. | PARAMETER   | CRITERIA   | Maximum Marks | Marks Awarded |
|------|---|--|---------------|---------------|
| 1.   | 9.6 Growth in Sales over previous year (%)<br>Average of three years to be worked out | More than 35% : 5<br>20 -35 % : 4<br>5 - 20 % : 3<br>>0 - 5 % : 2<br>0 or negative : 0 | 5             |               |
| 2.   | 9.7 PROFIT BEFORE TAX<br><br>Growth over previous year (%)                            | More than 20 % : 5<br>5 – 20 % : 4<br>>0 – 5 % : 3<br>0 or below : 0                   | 5             |               |

BHEL CERTIFIED ASSESSOR

**BHARAT HEAVY ELECTRICALS LIMITED  
SUPPLIER REGISTRATION FORM**

**FORM NO. SRF(I) 01 (INDIAN SUPPLIER)**

**ANNEXURE - 5**

Page 16 of 17

**Part D : SCORE SHEET**

**3. QUALITY SYSTEM :**

| S.N.         | PARAMETER  | CRITERIA  | Maxm. Marks | Marks Awarded |
|--------------|--|---|-------------|---------------|
| 1.           | Incoming Material control System   | System availability : Yes: 1<br>No : 0  | 1           |               |
|              |  | Availability of Organisation chart<br>Yes: 1<br>No : 0  | 1           |               |
| 2.           | Process control  | Work instruction available: Yes: 1<br>No : 0  | 1           |               |
|              |  | Record of process Control : Available : 2<br>Partial record : 1<br>Not available: 0   | 2           |               |
| 3.           | Manufacturing / Testing Procedure Qualification  | Procedure Qualification Specification :<br>Adequate : 3<br>In adequate: 1<br>Not available : 0  | 3           |               |
| 4.           | Personnel qualification  | Record of PQR:<br>Adequate : 3<br>In adequate: 1<br>Not available : 0   | 3           |               |
| 5.           | Calibration system   | Adequate : 3<br>In adequate: 1<br>Not available : 0   | 3           |               |
| 6.           | System of Identification & Traceability of materials, tools, jigs, fixtures & processed components, etc. | Procedure available :<br>Adequate : 2<br>In adequate: 1<br>Not available : 0  | 2           |               |
| 7.           | System of Storage/ preservation/ painting & packing  | Procedure available :<br>Adequate : 2<br>In adequate: 1<br>Not available : 0  | 2           |               |
| 8.           | System of NCR disposition & corrective preventive action   | Two copies of NCR & CAPA<br>Available :2<br>Not available : 0   | 2           |               |
| 9.           | Customer complaints handling system  | System available : Yes: 1<br>No : 0   | 1           |               |
|              |  | Complaints registered & resolved : 2<br>Complaints registered & partially resolved : 1<br>Complaints not registered or not resolved : 0 | 2           |               |
|              |  |   |             |               |
| 10.          | Safety measures  | System available : Yes: 1<br>No : 0   | 1           |               |
|              |  | Record available : Yes: 1<br>No : 0   | 1           |               |
| <b>TOTAL</b> |  |   | <b>25</b>   |               |

BHEL CERTIFIED ASSESSOR

**BHARAT HEAVY ELECTRICALS LIMITED  
SUPPLIER REGISTRATION FORM**

FORM NO. SRF(I) 01 (INDIAN SUPPLIER)

ANNEXURE - 5

Page 17 of 17

**Part D : SCORE SHEET**

**4. TECHNICAL COMPETENCE**

Column no. 1 to 4 to be filled by MISCC before sending to supplier. Column no. 5 to be filled by BHEL certified Assessor after evaluation of supplier response.

| Sl. No<br>(1) | Parameter<br>(2) | Scoring criteria<br>(3) | Maximum Marks<br>(4) | Marks obtained<br>(5) |
|---------------|------------------|-------------------------|----------------------|-----------------------|
|               |                  |                         |                      |                       |
|               |                  |                         |                      |                       |
|               |                  |                         |                      |                       |
|               | <b>TOTAL</b>     |                         | <b>25</b>            |                       |

**SUMMARY:**

| Sl. No | Criteria                 | Maxm Marks | Qualifying marks * | Marks obtained | Recommendation for registration  |
|--------|--------------------------|------------|--------------------|----------------|--|
| 1.     | Organisational Soundness | 50         | 30                 |                | <b>Recommended :</b><br><br>Permanent code<br>/Development code/<br>Trial code<br><br><b>Not recommended</b> |
|        | Financial Information    |            |                    |                |  |
| 2.     | Quality System           | 25         | 15                 |                |  |
| 3.     | Technical Competence     | 25         | 15                 |                |  |
|        | <b>TOTAL</b>             | <b>100</b> | <b>60</b>          |                |  |

**\*Minimum Qualifying Score in Each category shall be 60%.**

**REGISTRATION CRITERIA:**

| Sl. No | Score        | Recommendation   |
|--------|--------------|--|
| 1.     | More than 90 | Supplier is to be registered and given Permanent code, Normally no visit is called for.  |
| 2.     | >75<br><=90  | Supplier may be visited if recommended by MISCC or to be registered and given permanent code.  |
| 3.     | >=60<br><=75 | Supplier may carry out suggested improvements if advised by MISCC Supplier's visit is mandatory. Trial/ Development code may be given. |
| 4.     | Less than 60 | Not to be registered   |

**Note:** Indian Stockist/ Trader/ Distributor/ Dealer/ Authorised Agent/ Channel partner/ Indian Sales office or Subsidiary of registered foreign principal are to be awarded marks on pro-rata basis and registered accordingly.

Signatures: MISCC and Suppler Evaluation Team (in case of visit)

1)

2)

3)

4)

5)

6)

|                         |
|-------------------------|
| BHEL CERTIFIED ASSESSOR |
|-------------------------|

ANNEXURE - 6

**NON-DISCLOSURE AND PROPRIETARY INFORMATION AGREEMENT**

BETWEEN

\_\_\_\_\_ (Name of the Vendor),, having its registered offices in  
\_\_\_\_\_ (Address of Vendor), registered under the no.  
of the Companies' register of \_\_\_\_\_ (Name of Place and Country),  
capital stock of \_\_\_\_\_ (Value), with a place of business in  
\_\_\_\_\_ (Name of Place and Country) (hereinafter referred to as  
" \_\_\_\_\_ (Name of Vendor)");

AND

**Bharat Heavy Electricals Ltd** a company incorporated under the Indian Companies Act 1956 having its registered offices at BHEL House, Siri Fort, New Delhi -110 049 and having one of its works at Heavy Electrical Equipment Plant, Ranipur, Haridwar-249403 ( Uttarakhand), India registered under the No. 4281 of 1964-65 of the companies register of Delhi, capital stock of Rs 4895.2 million with a place of registered office in New Delhi (hereinafter referred to as “BHEL”) hereinafter also referred to individually as “the Party” or collectively as “the Parties”.

**BACKGROUND**

This Agreement sets forth the rights and obligations of the Parties with respect to the use, handling, protection and safeguarding of Proprietary Information that is disclosed by and between the Parties.

**WHEREAS**

A) the Parties wish to pursue exploratory discussions concerning a possible collaboration between them in relation to the Program defined in Exhibit 1;

B) during the ensuing discussions and negotiations it may occur that either Party discloses to the other technical, financial or business information of a proprietary or confidential nature, which the Parties intend to protect against, making it available, by any means to any third person, and other unauthorized use and/or further disclosure by the recipient, in accordance with the terms and conditions set forth herein;

**NOW, THEREFORE,** the Parties have agreed as follows:

1. The term “Proprietary Information” shall mean any information or data of whatsoever kind of a confidential or proprietary nature, including but not limited to, commercial information, know how and technical information in the form of designs, drawings, concepts, requirements, specifications, software, interfaces, components, processes, or the like, that have been or will be disclosed by either Party to the other pursuant to this Agreement, either in writing, orally or other form, which is designated as “Proprietary” or “Confidential” by the disclosing Party by means of formal declaration or an appropriate stamp, legend or any other written or orally notice .
2. Proprietary Information may be conveyed, without limitation, through any written or printed documents, samples, models, electronic form on disk, tape, other storage media or any other means of disclosing such Proprietary Information that either Party may elect to use during the life of this Agreement, but if an originating Party originally discloses information orally or visually, the receiving Party will protect such information as Proprietary Information to the extent that the originating Party :
  - identifies the Information as Proprietary at the time of original disclosure,
  - summarizes the Proprietary Information in writing .

Information stored in electronic form on disk, tape, other storage media will be adequately marked if a proprietary legend displays when the information originally runs on a computer system and when the information is printed from its data file.

Proprietary Information also includes any information which can be obtained by examination, testing or analysis of any hardware or material substance or any component part of such hardware or material substance provided by the Disclosing Party even though the requirements in Clause 1 for marking and designation have not been fulfilled.

3. Each Party, to the extent of its rights to do so, shall disclose to the other only the Proprietary Information which the disclosing Party deems appropriate to fulfil the objectives of this Agreement. The Parties hereby represent that the disclosure of Proprietary Information by and between themselves shall be made in compliance with, and subject to the laws and regulations of the Disclosing Party's country.
  
4. The receiving Party hereby agrees and covenants that, from the effective date of this Agreement until the expiry date as per article 11 and the following period as per article 12, the Proprietary Information that either Party receives from the other shall:
  - a) be protected and kept in strict confidence by the receiving Party which must use the same degree of care it uses to protect its own confidential information and in no case less than a reasonable care;
  
  - b) be only disclosed to and used by those persons within the receiving Party's organization or that of its parent or controlled companies who have a need to know and solely for the purposes specified in this Agreement, and be treated by such persons or entities with the same degree of care and subject to the same restrictions;
  
  - c) to procure that each third party to whom Proprietary Information is disclosed under this Agreement is made aware of the provisions of this Agreement prior to such disclosure to it and that each such third party is

bound by obligations of confidentiality which are no less onerous than those contained in this Agreement;

- d) neither be disclosed nor caused to be disclosed or made available, either directly or indirectly, to any third Party or persons other than those mentioned in subparagraph b) above or other persons upon which both of the contractual Parties shall agree in an amendment to this Agreement;
- e) not to copy, reproduce or reduce to writing any part of such Proprietary Information except as may be reasonably necessary for the purpose referred to in the Recitals of this Agreement

PROVIDED THAT the Receiving Party shall be entitled to make any disclosure required by court order or government or regulatory requirement of the Disclosing Party's Proprietary Information subject to notifying the Disclosing Party as soon as possible of such requirement

- 5. Any Proprietary Information and copies thereof disclosed by either Party to the other shall remain the property of the disclosing Party and shall be immediately returned or destroyed by the receiving Party upon request.
- 6. The receiving Party shall have no obligations or restrictions with respect to any Proprietary Information for which the receiving Party can prove that:
  - a) is in or which comes into the public domain otherwise than as a result of a breach of this Agreement by any person to whom a disclosure of Proprietary Information is made as permitted under this Agreement or of any other duty of confidentiality relating to the Proprietary Information of which the Receiving Party has knowledge; or
  - b) it has been in its possession without restriction at the time of the disclosure, as evidenced by written documentation in its files; or
  - c) it has been lawfully received from a third Party without breach of this Agreement; or

- d) it has been or is published without violation of this Agreement; or
  - e) it has been independently developed in good faith by employees of the receiving Party who did not have access to the Proprietary Information; or
  - f) it has not been properly declared, designated or confirmed as Proprietary or Confidential; or
  - g) the protection period has expired according to articles 11 and 12 of this Agreement.
7. With respect to any exchange of Proprietary Information which may occur as a result of this Agreement, it is expressly understood and agreed that the persons listed in Exhibit 2 shall, on behalf of the respective Parties, be the exclusive individuals authorized to receive from and transmit to the other Party Proprietary Information under this Agreement. Each Party may replace at any time its respective authorized individuals identified in such Exhibit 2, within its own organization. Any such new designation by a Party shall be made by written notice to the other at the address indicated in such Exhibit 2.
8. Any Proprietary Information which is identified as “Classified Information”, or whose export is subject to an export license, shall be identified as such by the disclosing Party at the time of disclosure and the disclosure, protection, use and handling thereof, shall remain subject to the security procedures and restrictions imposed by the disclosing Party's Government.
9. The disclosure of Proprietary Information under this Agreement by either Party to the other shall not be construed as granting to the receiving Party any right, whether express or implied by licence or otherwise, on the matters, inventions or discoveries to which such information pertains, or as granting any trademark, patents, copyrights, trade secret right or other form of intellectual property right.

10. Nothing in this Agreement may be construed as an obligation of either Party to disclose any Proprietary Information to the other, or to enter into any subsequent contractual relationship with such other Party.
11. This Agreement covers the exchange of Proprietary Information which may be made by either Party to the other until ten years from signing of the agreement or any extension thereto which may be agreed upon by the Parties in writing. Proprietary information relevant to the Program detailed in Exhibit 1, already made available to the other contractual Party before the effective date, shall also be protected under this Agreement.

It is understood by the parties that, prior to disclosure, the Disclosing Party shall have obtained any government authorisation needed for the export of the Proprietary Information

12. The expiry of the period contemplated in Article 11 of this Agreement shall not relieve the receiving Party from complying with the obligations imposed by Article 4 here above with respect to the use and protection of the Proprietary Information, received prior the date of such expiry, for a period of ten (10) years after such expiry.
13. The Parties are independent contractors. Each will bear all costs and expenses in connection with this Agreement. This Agreement is intended to facilitate only the exchange of Proprietary Information and is not intended to be, and shall not be construed to create a teaming agreement, joint venture, association, partnership, or other business organisation or agency arrangement and no Party shall have the authority to bind the other without the other Party's separate prior written agreement .
14. This Agreement shall be governed by and shall be interpreted in accordance with the substantive federal laws of Switzerland excluding it's choice of law rules.

Irrespective of the foregoing each Party shall remain bound by the provisions of its own national laws and regulations with respect to the transfer or use of Classified Information or information whose export is subject to an export license.

15. All disputes among the Parties, in connection with or arising out of the existence, validity, construction, performance and termination of this Agreement (or any terms thereof), which the Parties are unable to resolve among themselves, shall be finally settled by an Arbitration. The Arbitration shall be held in Geneva (CH) in English language, in accordance with the rules of the ICC – International Chamber of Commerce by three arbitrators appointed in accordance with said rules.
16. The foregoing constitutes the entire Agreement among the Parties with respect to the subject matter hereof and supersedes and cancels all prior representations, negotiations, commitments, undertakings, communications, either oral or written, acceptances, understandings and agreements among the Parties with respect to or in connection with any of the matters to which such Agreement applies or refers.
17. Notices to \_\_\_\_\_ (**Name of Vendor**) shall be made at the following address:

**(Complete Address of Vendor)**

Attention: Mr. \_\_\_\_\_ (**Name of the Authorised Person of Vendor**)

Notices to BHEL shall be made at the following address:

BHARAT HEAVY ELECTRICALS LIMITED,

HEAVY ELECTRICAL EQUIPMENT PLANT,

Ranipur, Haridwar-249403 (Uttarakhand), India

Attention: Shri B.M.Bansal, General Manager- Materials Management

18. The effective date of this Agreement shall be the date of the last signature appearing herein.

**IN WITNESS WHEREOF**, each of the Parties has caused this Agreement, to be executed by its duly authorized officer.

Date :

Signed for and on behalf of

Signed for and on behalf of

**(Name of Vendor)**

BHEL

By:

By:

Title:

Title:

Signature:

Signature:

**EXHIBIT 1**

to the

**NON-DISCLOSURE AGREEMENT**

between

\_\_\_\_\_ **(Name of Vendor)**

and

**BHARAT HEAVY ELECTRICALS LIMITED**

dated:

\_\_\_\_\_

The Non Disclosure Agreement covers the exchange of Proprietary Information which may occur during the discussions and negotiations in view of a possible cooperation between the Parties in the following programs:

-Description of Material or Services for which the order is placed

\_\_\_\_\_ **(Name of Vendor)** list of products that require an exchange of Proprietary Information which may be occur during the discussions and negotiations in view of a possible cooperation for the above programs :

COPYRIGHT AND CONFIDENTIAL  
THE INFORMATION ON THIS DOCUMENT IS THE PROPERTY OF BHARAT  
HEAVY ELECTRICALS LIMITED. IT MUST NOT BE USED DIRECTLY  
OR INDIRECTLY IN ANY WAY DETRIMENTAL TO THE INTEREST OF COMPANY.

FIRST ANGLE PROJECTION

(ALL DIMENSIONS ARE IN mm)

FORM DG38(B)

3.2  
✓ THE REST

DRAWING No. R2128-1420

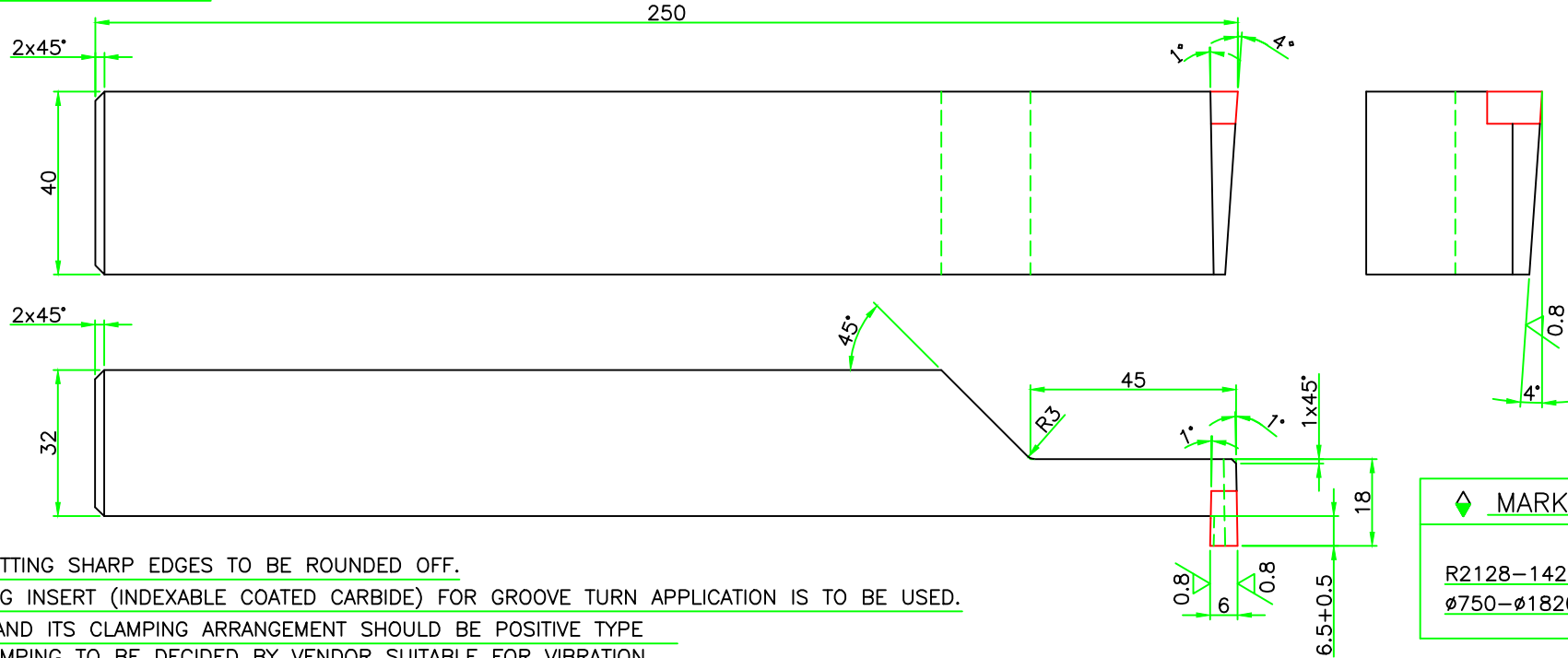

NOTES:-

- 1-NON-CUTTING SHARP EDGES TO BE ROUNDED OFF.
- \*\*2-GROOVING INSERT (INDEXABLE COATED CARBIDE) FOR GROOVE TURN APPLICATION IS TO BE USED.
- \*\*3-INSERT AND ITS CLAMPING ARRANGEMENT SHOULD BE POSITIVE TYPE SCREW CLAMPING TO BE DECIDED BY VENDOR SUITABLE FOR VIBRATION FREE & PRECISION FACE GROOVING ON ALLOY STEEL CASTINGS ON BORE DIA ø750-ø1820.
- \*4-ANY STEEL HAVING MINIMUM TENSILE STRENGTH 75Kg/mm<sup>2</sup>
- 5-VENDOR TO PROVIDE DETAILS OF GROOVING INSERT AND OTHER CONSUMABLE/SPARES LIKE SCREW,CLAMP,SHIMS ETC.
- 6-ACCEPTANCE OF TOOL ONLY AFTER SUCCESSFUL TRIAL MACHINING ON CUTTING SPEED=50 METER/MINUTE AND FEED=0.1 MM/REV. IN SHOP.
- 7-CONSERVATION TO BE DONE AS PER TL-30007.

|          |             |     |             |                      |        |             |
|----------|-------------|-----|-------------|----------------------|--------|-------------|
| 02       | INSERT      |     |             | **                   |        | --          |
| 01       | SHANK       |     |             | *                    |        | --          |
| ITEM No. | DESCRIPTION | STD | DRAWING No. | MATERIAL CODE        | A UNIT | UNIT WEIGHT |
|          |             |     |             | VAR. MATERIAL SPECN. | C      | QTY.        |

|                                   |         |               |       |                                   |                  |                            |               |
|-----------------------------------|---------|---------------|-------|-----------------------------------|------------------|----------------------------|---------------|
| GMS No./GR.SP.No.                 |         | STATUS OF DRG |       | TYPE OF PRODUCT                   | COMP. DRG. No.   | M/C TOOL TRANS No.         | REF. DRG. No. |
| AGREED DEPT.                      |         | NAME          | SIGN. | DATE                              | ST 700MW         | 01060251000                | 274           |
| NCT                               |         | ATUL          | -Sd-  | 17.12.14                          | DESIGN ORDER No. | M/C MODEL No.              | AS PER SKETCH |
|                                   |         |               |       |                                   | NC/ST-70/T/1446  | 7.5M CNC VERT. BOR.(1-032) |               |
| GRADE OF UNTOL. DIM.:-            |         |               |       | BHARAT HEAVY ELECTRICALS LTD.     |                  | NAME                       |               |
| M/CG- <del>L</del> /W/F AA0230208 |         |               |       | HARDWAR                           |                  | SIGN.                      |               |
| WELDING-A/B/C/D AA0621104         |         |               |       | DRN                               |                  | G.SHAYAM                   |               |
| GAS CUTTING-'T3' AA0621101        |         |               |       | CHD                               |                  | RAVI                       |               |
| REV                               |         |               |       | APD                               |                  | ANKUR                      |               |
| DATE                              | ALTERED | REV           | DATE  | ALTERED                           | DEPT.            | SCALE                      | WEIGHT(Kg)    |
|                                   | CHECKED |               |       | CHECKED                           | JTE              | NTS                        | ~2.1          |
|                                   |         |               |       | CODE                              |                  | REF.TO ASSY. DRG.          |               |
|                                   |         |               |       | 209                               |                  | ITEM No. OF                |               |
|                                   |         |               |       | TITLE                             |                  | No. OF                     |               |
|                                   |         |               |       | L.H. CRANK FACE GROOVING TOOL W=6 |                  | SHEETS                     |               |
|                                   |         |               |       | DRAWING No.                       |                  | 01                         |               |
|                                   |         |               |       | R2128-1420                        |                  | 01                         |               |
|                                   |         |               |       | SHEET No.01                       |                  | No. OF SHEETS              |               |
|                                   |         |               |       |                                   |                  | 01                         |               |

SIZE A 3

COPYRIGHT AND CONFIDENTIAL  
THE INFORMATION ON THIS DOCUMENT IS THE PROPERTY OF BHARAT  
HEAVY ELECTRICALS LIMITED. IT MUST NOT BE USED DIRECTLY  
OR INDIRECTLY IN ANY WAY DETRIMENTAL TO THE INTEREST OF COMPANY.

FIRST ANGLE PROJECTION

(ALL DIMENSIONS ARE IN mm)

FORM DG38(B)

DRAWING No. R2128-1421

250

3.2/  
THE REST

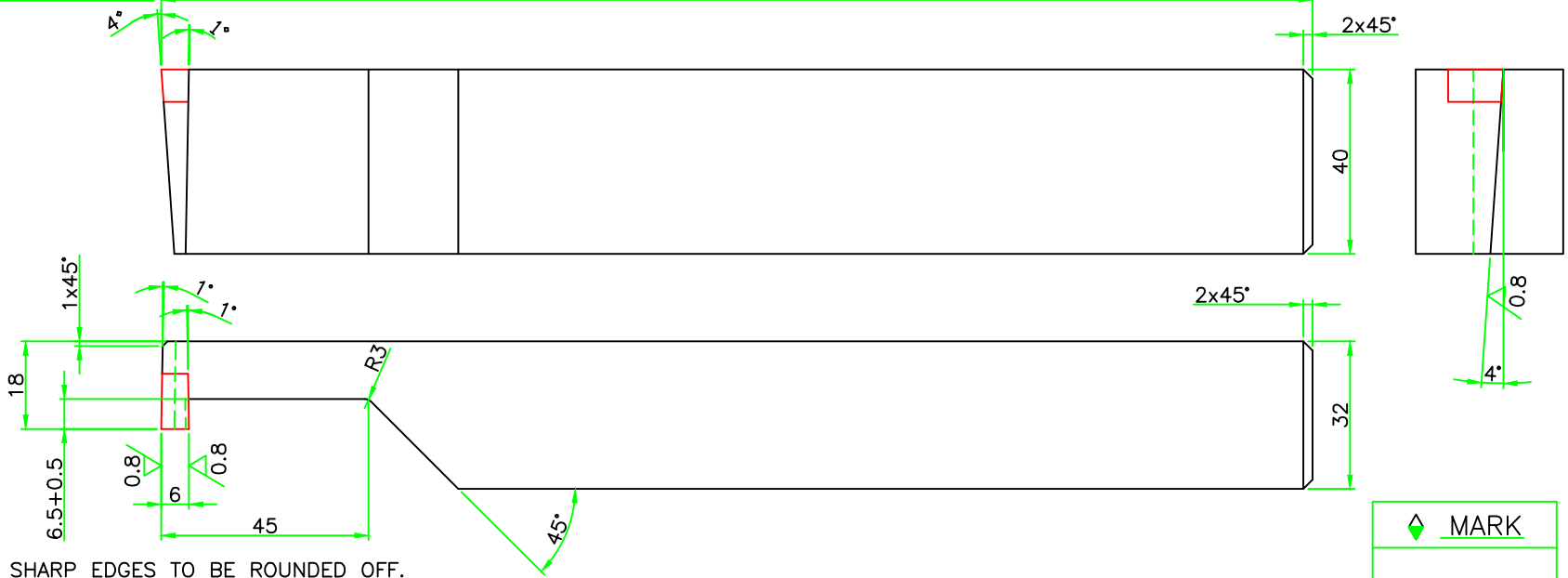

NOTES:-

- 1-NON-CUTTING SHARP EDGES TO BE ROUNDED OFF.
- \*\*2-GROOVING INSERT (INDEXABLE COATED CARBIDE) FOR GROOVE TURN APPLICATION IS TO BE USED.
- \*\*3-INSERT AND ITS CLAMPING ARRANGEMENT SHOULD BE POSITIVE TYPE SCREW CLAMPING TO BE DECIDED BY VENDOR SUITABLE FOR VIBRATION FREE & PRECISION FACE GROOVING ON ALLOY STEEL CASTINGS ON BORE DIA  $\phi 750-\phi 1820$ .
- \*4-ANY STEEL HAVING MINIMUM TENSILE STRENGTH 75Kg/mm<sup>2</sup>
- 5-VENDOR TO PROVIDE DETAILS OF GROOVING INSERT AND OTHER CONSUMABLE/SPARES LIKE SCREW,CLAMP,SHIMS ETC.
- 6-ACCEPTANCE OF TOOL ONLY AFTER SUCCESSFUL TRIAL MACHINING ON CUTTING SPEED=50 METER/MINUTE AND FEED=0.1 MM/REV. IN SHOP.
- 7-CONSERVATION TO BE DONE AS PER TL-30007.

◇ MARK  
R2128-1421  
 $\phi 750-\phi 1820$

| ITEM No. | DESCRIPTION | UNIT | DRAWING No. | MATERIAL CODE | A               | UNIT | UNIT WEIGHT |
|----------|-------------|------|-------------|---------------|-----------------|------|-------------|
|          |             |      |             | VAR.          | MATERIAL SPECN. | C    | QTY.        |
| 02       | INSERT      |      |             | **            |                 |      | --          |
|          |             |      |             |               |                 |      | 01          |
| 01       | SHANK       |      |             | *             |                 |      | --          |
|          |             |      |             |               |                 |      | 01          |

INVENTORY No. SIGN.&DATE REF. DRG. No.

|                        |  |                                   |  |                           |  |                            |  |                    |  |               |  |
|------------------------|--|-----------------------------------|--|---------------------------|--|----------------------------|--|--------------------|--|---------------|--|
| GMS No./GR.SP.No.      |  | STATUS OF DRG                     |  | TYPE OF PRODUCT           |  | COMP. DRG. No.             |  | M/C TOOL TRANS No. |  | REF. DRG. No. |  |
| AGREED DEPT.           |  | NAME                              |  | SIGN.                     |  | DATE                       |  | ST 700MW           |  | 01060251000   |  |
| NCT                    |  | ATUL                              |  | -Sd-                      |  | 17.12.14                   |  |                    |  | 274           |  |
| DESIGN ORDER No.       |  | M/C MODEL No.                     |  | NC/ST-70/T/1447           |  | 7.5M CNC VERT. BOR.(1-032) |  | AS PER SKETCH      |  |               |  |
| GRADE OF UNTOL. DIM.:- |  | M/CG- <del>L</del> /M/F AA0230208 |  | WELDING-A/B/C/D AA0621104 |  | GAS CUTTING-'T3' AA0621101 |  | NAME               |  | SIGN.         |  |
| REV                    |  | DATE                              |  | ALTERED                   |  | CHECKED                    |  | DRN                |  | 17.12.14      |  |
|                        |  |                                   |  |                           |  |                            |  | G.SHAYAM           |  | -Sd-          |  |
|                        |  |                                   |  |                           |  |                            |  | CHD                |  | 17.12.14      |  |
|                        |  |                                   |  |                           |  |                            |  | APD                |  | -Sd-          |  |
|                        |  |                                   |  |                           |  |                            |  | ANKUR              |  | 17.12.14      |  |
| DEPT.                  |  | JTE                               |  | SCALE                     |  | WEIGHT(Kg)                 |  | REF.TO ASSY. DRG.  |  | ITEM No. OF   |  |
| CODE                   |  | 209                               |  | NTS                       |  | ~2.1                       |  |                    |  | No. ITEMS     |  |
| TITLE                  |  | R.H. CRANK FACE GROOVING TOOL W=6 |  | DRAWING No.               |  | R2128-1421                 |  | REV                |  |               |  |
| SHEET No.              |  | 01                                |  | No. OF SHEETS             |  | 01                         |  |                    |  |               |  |

SIZE A 3

COPYRIGHT AND CONFIDENTIAL  
THE INFORMATION ON THIS DOCUMENT IS THE PROPERTY OF BHARAT  
HEAVY ELECTRICALS LIMITED. IT MUST NOT BE USED DIRECTLY  
OR INDIRECTLY IN ANY WAY DETRIMENTAL TO THE INTEREST OF COMPANY.

FIRST ANGLE PROJECTION

(ALL DIMENSIONS ARE IN mm)

FORM DG38(B)

3.2  
✓ THE REST

DRAWING No. R2128-1422

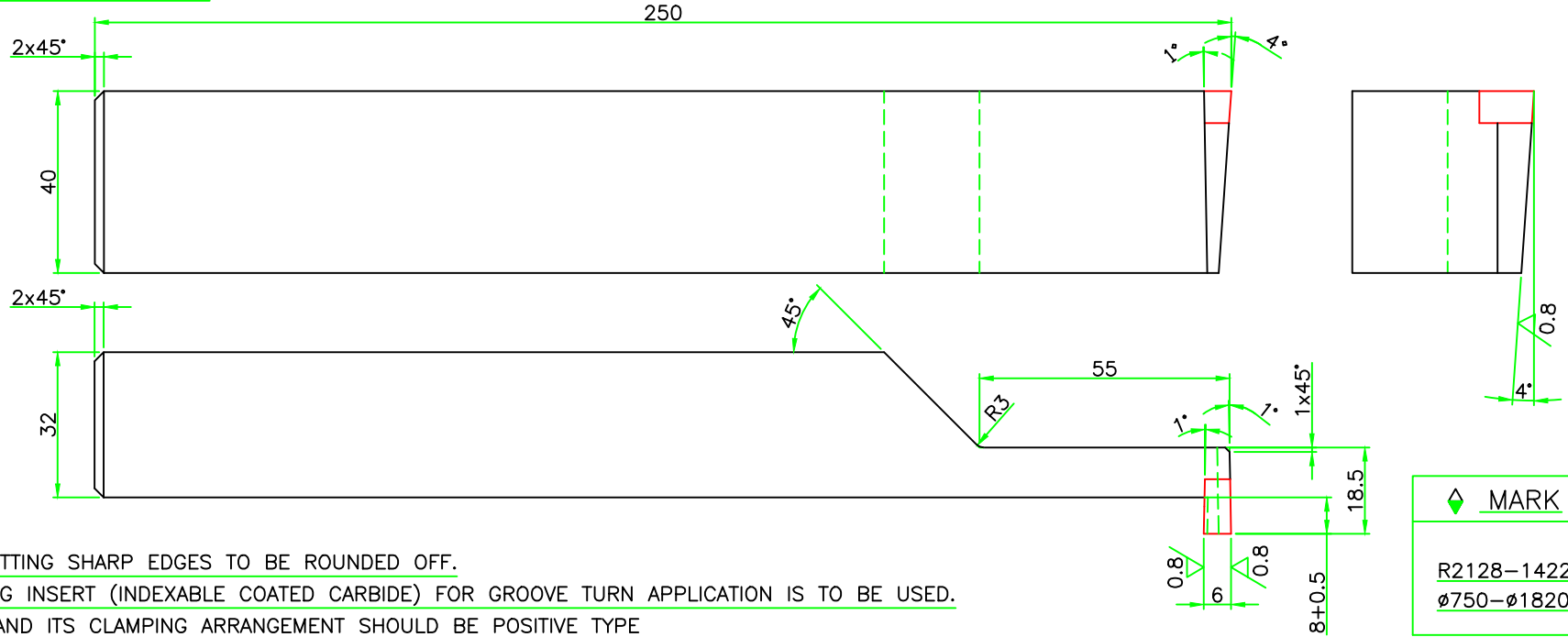

MARK  
R2128-1422  
ø750-ø1820

NOTES:-

- 1-NON-CUTTING SHARP EDGES TO BE ROUNDED OFF.
- \*\*2-GROOVING INSERT (INDEXABLE COATED CARBIDE) FOR GROOVE TURN APPLICATION IS TO BE USED.
- \*\*3-INSERT AND ITS CLAMPING ARRANGEMENT SHOULD BE POSITIVE TYPE SCREW CLAMPING TO BE DECIDED BY VENDOR SUITABLE FOR VIBRATION FREE & PRECISION FACE GROOVING ON ALLOY STEEL CASTINGS ON BORE DIA ø750-ø1820.
- \*4-ANY STEEL HAVING MINIMUM TENSILE STRENGTH 75Kg/mm<sup>2</sup>
- 5-VENDOR TO PROVIDE DETAILS OF GROOVING INSERT AND OTHER CONSUMABLE/SPARES LIKE SCREW,CLAMP,SHIMS ETC.
- 6-ACCEPTANCE OF TOOL ONLY AFTER SUCCESSFUL TRIAL MACHINING ON CUTTING SPEED=50 METER/MINUTE AND FEED=0.1 MM/REV. IN SHOP.
- 7-CONSERVATION TO BE DONE AS PER TL-30007.

|          |             |     |             |                      |        |             |
|----------|-------------|-----|-------------|----------------------|--------|-------------|
| 02       | INSERT      |     |             | **                   |        | --          |
| 01       | SHANK       |     |             | *                    |        | --          |
| ITEM No. | DESCRIPTION | STD | DRAWING No. | MATERIAL CODE        | A UNIT | UNIT WEIGHT |
|          |             |     |             | VAR. MATERIAL SPECN. | C      | QTY.        |

|                        |      |                         |     |                 |         |                 |     |                    |            |                            |             |
|------------------------|------|-------------------------|-----|-----------------|---------|-----------------|-----|--------------------|------------|----------------------------|-------------|
| GMS No./GR.SP.No.      |      | STATUS OF DRG           |     | TYPE OF PRODUCT |         | COMP. DRG. No.  |     | M/C TOOL TRANS No. |            | REF. DRG. No.              |             |
| AGREED DEPT.           |      | NAME                    |     | SIGN.           |         | DATE            |     | ST 700MW           |            | 01060251000                |             |
| NCT                    |      | ATUL                    |     | -Sd-            |         | 17.12.14        |     | DESIGN ORDER No.   |            | M/C MODEL No.              |             |
|                        |      |                         |     |                 |         |                 |     | NC/ST-70/T/1448    |            | 7.5M CNC VERT. BOR.(1-032) |             |
| GRADE OF UNTOL. DIM.:- |      | M/CG- <del>L</del> /W/F |     | AA0230208       |         | WELDING-A/B/C/D |     | AA0621104          |            | GAS CUTTING-'T3'           |             |
|                        |      |                         |     |                 |         |                 |     |                    |            | AA0621101                  |             |
| REV                    | DATE | ALTERED                 | REV | DATE            | ALTERED | DEPT.           | JTE | SCALE              | WEIGHT(Kg) | REF.TO ASSY. DRG.          | ITEM No. OF |
|                        |      | CHECKED                 |     |                 | CHECKED |                 | 209 | NTS                | ~2.1       |                            | No. OF      |
|                        |      |                         |     |                 |         |                 |     |                    |            | DRAWING No.                |             |
|                        |      |                         |     |                 |         |                 |     |                    |            | R2128-1422                 |             |
|                        |      |                         |     |                 |         |                 |     |                    |            | SHEET No.01                |             |
|                        |      |                         |     |                 |         |                 |     |                    |            | No. OF SHEETS 01           |             |

**BHEL** BHARAT HEAVY ELECTRICALS LTD.  
HARDWAR

TITLE  
L.H. CRANK FACE GROOVING TOOL W=6

|     |          |       |      |      |          |             |
|-----|----------|-------|------|------|----------|-------------|
| DRN | G.SHAYAM | SIGN. | -Sd- | DATE | 17.12.14 | No. OF VAR. |
| CHD | RAVI     | SIGN. | -Sd- | DATE | 17.12.14 |             |
| APD | ANKUR    | SIGN. | -Sd- | DATE | 17.12.14 |             |

SIZE A 3

COPYRIGHT AND CONFIDENTIAL  
THE INFORMATION ON THIS DOCUMENT IS THE PROPERTY OF BHARAT  
HEAVY ELECTRICALS LIMITED. IT MUST NOT BE USED DIRECTLY  
OR INDIRECTLY IN ANY WAY DETRIMENTAL TO THE INTEREST OF COMPANY.

FIRST ANGLE PROJECTION

(ALL DIMENSIONS ARE IN mm)

FORM DG38(B)

DRAWING No. R2128-1423

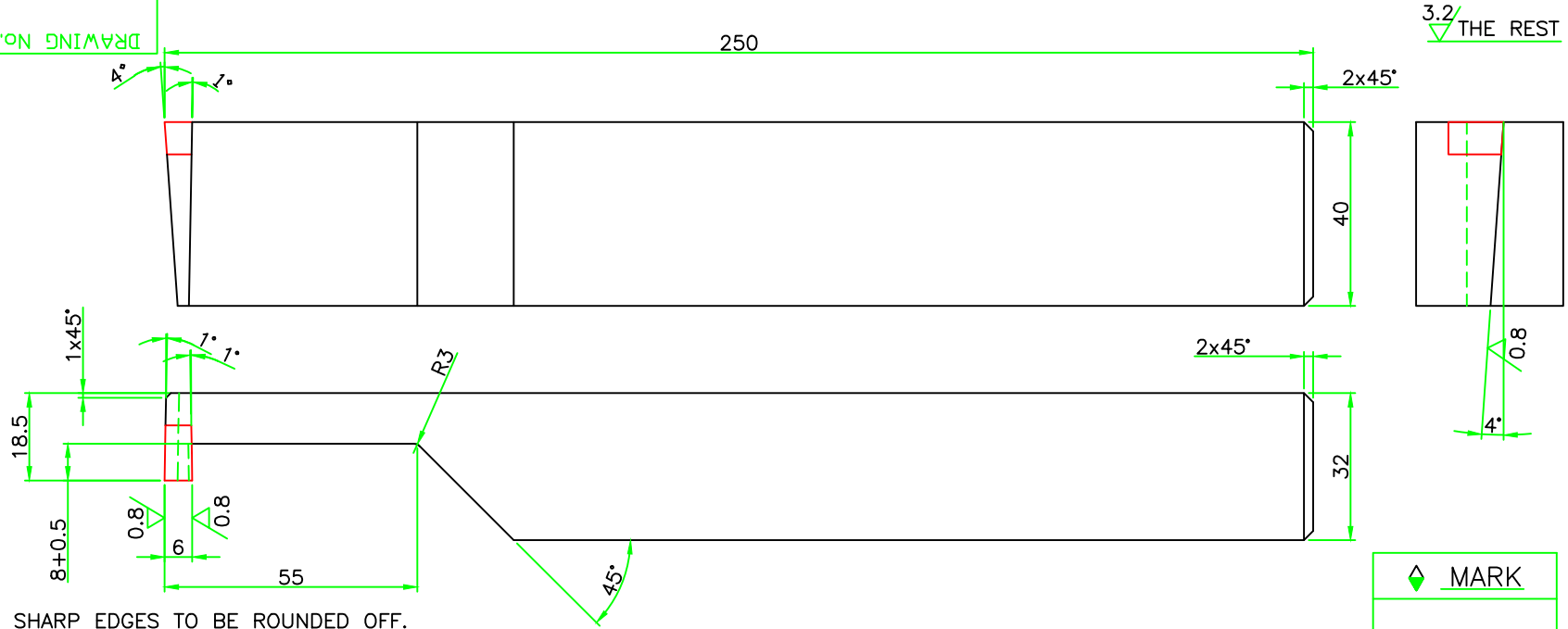

◇ MARK  
R2128-1423  
ø750-ø1820

NOTES:-

- 1-NON-CUTTING SHARP EDGES TO BE ROUNDED OFF.
- \*\*2-GROOVING INSERT (INDEXABLE COATED CARBIDE) FOR GROOVE TURN APPLICATION IS TO BE USED.
- \*\*3-INSERT AND ITS CLAMPING ARRANGEMENT SHOULD BE POSITIVE TYPE SCREW CLAMPING TO BE DECIDED BY VENDOR SUITABLE FOR VIBRATION FREE & PRECISION FACE GROOVING ON ALLOY STEEL CASTINGS ON BORE DIA ø750-ø1820.
- \*4-ANY STEEL HAVING MINIMUM TENSILE STRENGTH 75Kg/mm2
- 5-VENDOR TO PROVIDE DETAILS OF GROOVING INSERT AND OTHER CONSUMABLE/SPARES LIKE SCREW,CLAMP,SHIMS ETC.
- 6-ACCEPTANCE OF TOOL ONLY AFTER SUCCESSFUL TRIAL MACHINING ON CUTTING SPEED=50 METER/MINUTE AND FEED=0.1 MM/REV. IN SHOP.
- 7-CONSERVATION TO BE DONE AS PER TL-30007.

| ITEM No. | DESCRIPTION | QTY | DRAWING No. | MATERIAL CODE | A               | UNIT | UNIT WEIGHT |
|----------|-------------|-----|-------------|---------------|-----------------|------|-------------|
|          |             |     |             | VAR.          | MATERIAL SPECN. | c    | QTY.        |
| 02       | INSERT      |     |             | **            |                 |      | --          |
|          |             |     |             |               |                 |      | 01          |
| 01       | SHANK       |     |             | *             |                 |      | --          |
|          |             |     |             |               |                 |      | 01          |

INVENTORY No. SIGN.&DATE REF. DRG. No.

|                                   |  |                                   |  |                           |  |                            |  |                    |  |               |  |
|-----------------------------------|--|-----------------------------------|--|---------------------------|--|----------------------------|--|--------------------|--|---------------|--|
| GMS No./GR.SP.No.                 |  | STATUS OF DRG                     |  | TYPE OF PRODUCT           |  | COMP. DRG. No.             |  | M/C TOOL TRANS No. |  | REF. DRG. No. |  |
| AGREED DEPT.                      |  | NAME                              |  | SIGN.                     |  | DATE                       |  | ST 700MW           |  | 01060251000   |  |
| NCT                               |  | ATUL                              |  | -Sd-                      |  | 17.12.14                   |  |                    |  | 274           |  |
| DESIGN ORDER No.                  |  | M/C MODEL No.                     |  |                           |  |                            |  |                    |  | AS PER SKETCH |  |
| NC/ST-70/T/1449                   |  | 7.5M CNC VERT. BOR.(1-032)        |  |                           |  |                            |  |                    |  |               |  |
| GRADE OF UNTOL. DIM.:-            |  | M/CG- <del>L</del> /W/F AA0230208 |  | WELDING-A/B/C/D AA0621104 |  | GAS CUTTING-'T3' AA0621101 |  | NAME               |  | SIGN.         |  |
| REV                               |  | DATE                              |  | ALTERED                   |  | CHECKED                    |  | DRN                |  | 17.12.14      |  |
|                                   |  |                                   |  |                           |  |                            |  | G.SHAYAM           |  | -Sd-          |  |
|                                   |  |                                   |  |                           |  |                            |  | CHD                |  | 17.12.14      |  |
|                                   |  |                                   |  |                           |  |                            |  | APD                |  | 17.12.14      |  |
|                                   |  |                                   |  |                           |  |                            |  | ANKUR              |  | -Sd-          |  |
| DEPT. JTE                         |  | SCALE                             |  | WEIGHT(Kg)                |  | REF.TO ASSY. DRG.          |  | ITEM No. OF        |  | No. OF        |  |
| CODE 209                          |  | NTS                               |  | ~2.1                      |  |                            |  | No. ITEMS          |  |               |  |
| TITLE                             |  | DRAWING No.                       |  | REV                       |  |                            |  |                    |  |               |  |
| R.H. CRANK FACE GROOVING TOOL W=6 |  | R2128-1423                        |  |                           |  |                            |  |                    |  |               |  |
| SHEET No.01                       |  | No. OF SHEETS                     |  | 01                        |  |                            |  |                    |  |               |  |

SIZE A 3

COPYRIGHT AND CONFIDENTIAL  
THE INFORMATION ON THIS DOCUMENT IS THE PROPERTY OF BHARAT  
HEAVY ELECTRICALS LIMITED. IT MUST NOT BE USED DIRECTLY  
OR INDIRECTLY IN ANY WAY DETRIMENTAL TO THE INTEREST OF COMPANY.

FIRST ANGLE PROJECTION

(ALL DIMENSIONS ARE IN mm)

FORM DG38(B)

3.2  
✓ THE REST

DRAWING No. R2128-1424

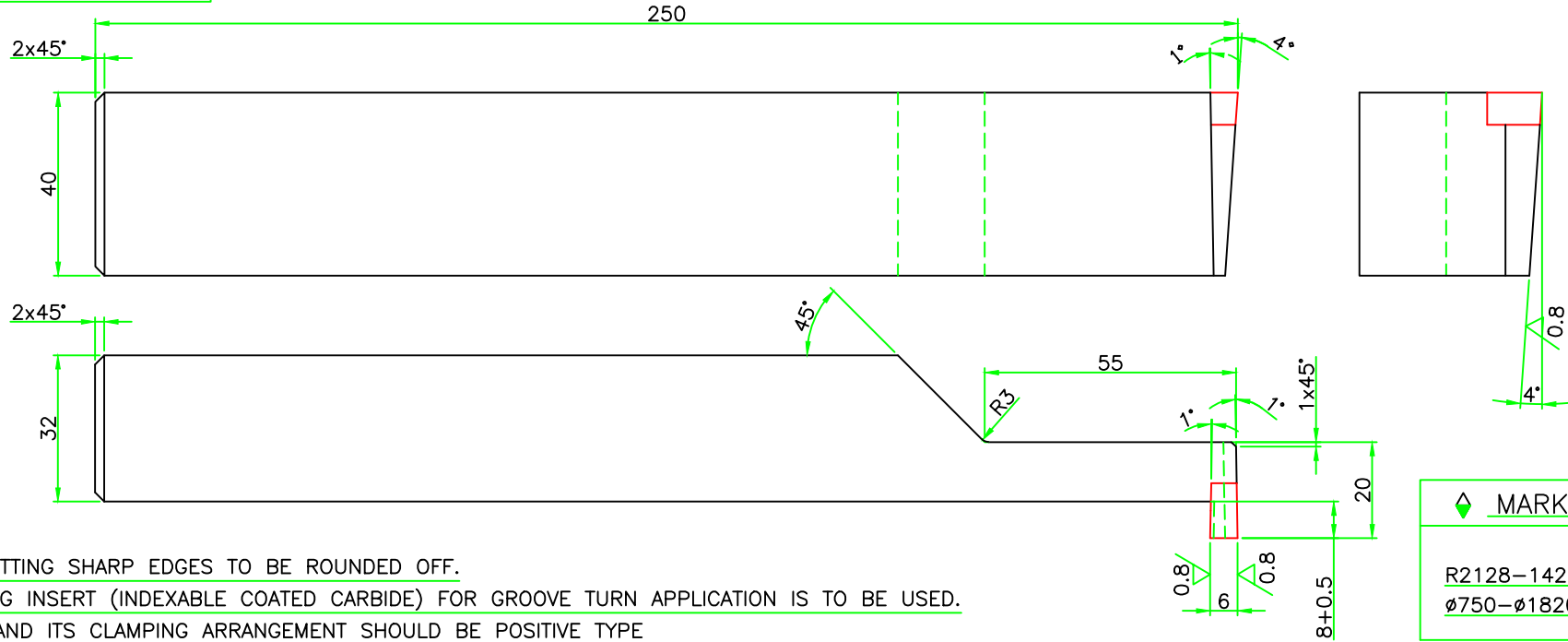

NOTES:-

- 1-NON-CUTTING SHARP EDGES TO BE ROUNDED OFF.
- \*\*2-GROOVING INSERT (INDEXABLE COATED CARBIDE) FOR GROOVE TURN APPLICATION IS TO BE USED.
- \*\*3-INSERT AND ITS CLAMPING ARRANGEMENT SHOULD BE POSITIVE TYPE SCREW CLAMPING TO BE DECIDED BY VENDOR SUITABLE FOR VIBRATION FREE & PRECISION FACE GROOVING ON ALLOY STEEL CASTINGS ON BORE DIA  $\phi 750-\phi 1820$ .
- \*4-ANY STEEL HAVING MINIMUM TENSILE STRENGTH 75Kg/mm<sup>2</sup>
- 5-VENDOR TO PROVIDE DETAILS OF GROOVING INSERT AND OTHER CONSUMABLE/SPARES LIKE SCREW,CLAMP,SHIMS ETC.
- 6-ACCEPTANCE OF TOOL ONLY AFTER SUCCESSFUL TRIAL MACHINING ON CUTTING SPEED=50 METER/MINUTE AND FEED=0.1 MM/REV. IN SHOP.
- 7-CONSERVATION TO BE DONE AS PER TL-30007.

|                      |
|----------------------|
| ◆ MARK               |
| R2128-1424           |
| $\phi 750-\phi 1820$ |

|          |             |     |             |                      |        |             |
|----------|-------------|-----|-------------|----------------------|--------|-------------|
| 02       | INSERT      |     |             | **                   |        | --          |
| 01       | SHANK       |     |             | *                    |        | 01          |
| ITEM No. | DESCRIPTION | STD | DRAWING No. | MATERIAL CODE        | A UNIT | UNIT WEIGHT |
|          |             |     |             | VAR. MATERIAL SPECN. | C      | QTY.        |

|                        |  |                                   |  |                           |  |                            |  |                            |  |                  |  |
|------------------------|--|-----------------------------------|--|---------------------------|--|----------------------------|--|----------------------------|--|------------------|--|
| GMS No./GR.SP.No.      |  | STATUS OF DRG                     |  | TYPE OF PRODUCT           |  | COMP. DRG. No.             |  | M/C TOOL TRANS No.         |  | REF. DRG. No.    |  |
| AGREED DEPT.           |  | NAME                              |  | SIGN.                     |  | DATE                       |  | ST 660MW                   |  | 01060256000      |  |
| NCT                    |  | ATUL                              |  | -Sd-                      |  | 18.12.14                   |  | 7.5M CNC VERT. BOR.(1-032) |  | AS PER SKETCH    |  |
| GRADE OF UNTOL. DIM.:- |  | M/CG- <del>L</del> /W/F AA0230208 |  | WELDING-A/B/C/D AA0621104 |  | GAS CUTTING-'T3' AA0621101 |  | NAME                       |  | SIGN.            |  |
| REV                    |  | DATE                              |  | ALTERED                   |  | CHECKED                    |  | DRN                        |  | G.SHAYAM         |  |
|                        |  |                                   |  |                           |  |                            |  | CHD                        |  | RAVI             |  |
|                        |  |                                   |  |                           |  |                            |  | APD                        |  | ANKUR            |  |
|                        |  |                                   |  |                           |  |                            |  | SCALE                      |  | WEIGHT(Kg)       |  |
|                        |  |                                   |  |                           |  |                            |  | NTS                        |  | ~2.1             |  |
|                        |  |                                   |  |                           |  |                            |  | REF.TO ASSY. DRG.          |  | ITEM No. OF      |  |
|                        |  |                                   |  |                           |  |                            |  | DRAWING No.                |  | REV              |  |
|                        |  |                                   |  |                           |  |                            |  | R2128-1424                 |  |                  |  |
|                        |  |                                   |  |                           |  |                            |  | SHEET No.01                |  | No. OF SHEETS 01 |  |

**BHHEL** BHARAT HEAVY ELECTRICALS LTD.  
HARDWAR

DEPT. JTE  
CODE 209

TITLE  
L.H. CRANK FACE GROOVING TOOL W=6

DATE 18.12.14  
SIGN. -Sd-  
DATE 18.12.14  
SIGN. -Sd-  
DATE 18.12.14  
SIGN. -Sd-

REF. TO ASSY. DRG.  
ITEM No. OF  
REV

SIZE A 3

INVENTORY No. SIGN.&DATE REF. DRG. No.

COPYRIGHT AND CONFIDENTIAL  
THE INFORMATION ON THIS DOCUMENT IS THE PROPERTY OF BHARAT  
HEAVY ELECTRICALS LIMITED. IT MUST NOT BE USED DIRECTLY  
OR INDIRECTLY IN ANY WAY DETRIMENTAL TO THE INTEREST OF COMPANY.

FIRST ANGLE PROJECTION

(ALL DIMENSIONS ARE IN mm)

FORM DG38(B)

3.2/  
THE REST

DRAWING No. R2128-1425

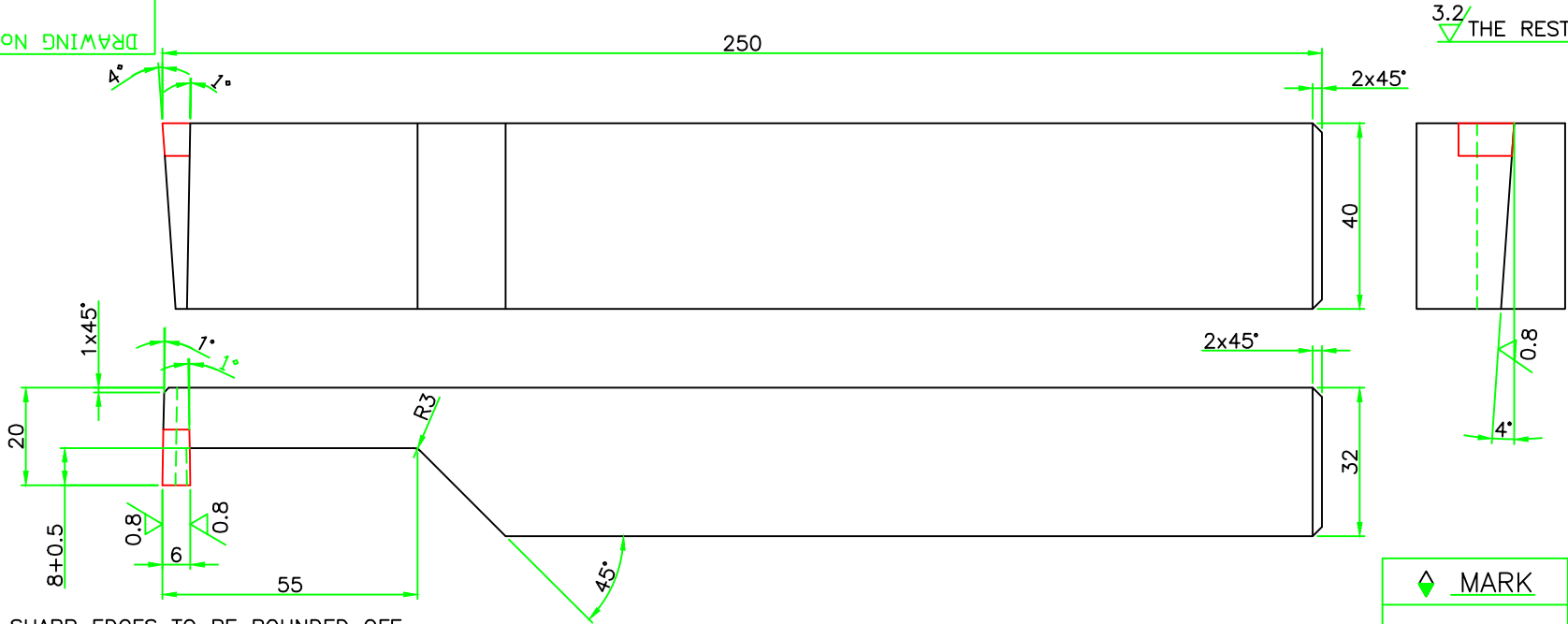

NOTES:-

- 1-NON-CUTTING SHARP EDGES TO BE ROUNDED OFF.
- \*\*2-GROOVING INSERT (INDEXABLE COATED CARBIDE) FOR GROOVE TURN APPLICATION IS TO BE USED.
- \*\*3-INSERT AND ITS CLAMPING ARRANGEMENT SHOULD BE POSITIVE TYPE SCREW CLAMPING TO BE DECIDED BY VENDOR SUITABLE FOR VIBRATION FREE & PRECISION FACE GROOVING ON ALLOY STEEL CASTINGS ON BORE DIA  $\phi 750-\phi 1820$ .
- \*4-ANY STEEL HAVING MINIMUM TENSILE STRENGTH 75Kg/mm<sup>2</sup>
- 5-VENDOR TO PROVIDE DETAILS OF GROOVING INSERT AND OTHER CONSUMABLE/SPARES LIKE SCREW,CLAMP,SHIMS ETC.
- 6-ACCEPTANCE OF TOOL ONLY AFTER SUCCESSFUL TRIAL MACHINING ON CUTTING SPEED=50 METER/MINUTE AND FEED=0.1 MM/REV. IN SHOP.
- 7-CONSERVATION TO BE DONE AS PER TL-30007.

◇ MARK  
R2128-1425  
 $\phi 750-\phi 1820$

|          |             |     |             |                      |        |             |
|----------|-------------|-----|-------------|----------------------|--------|-------------|
| 02       | INSERT      |     |             | **                   |        | --          |
| 01       | SHANK       |     |             | *                    |        | 01          |
| ITEM No. | DESCRIPTION | QTY | DRAWING No. | MATERIAL CODE        | A UNIT | UNIT WEIGHT |
|          |             |     |             | VAR. MATERIAL SPECN. | c      | QTY.        |

|                        |      |                         |     |                 |         |                                   |     |                    |            |                            |          |           |  |
|------------------------|------|-------------------------|-----|-----------------|---------|-----------------------------------|-----|--------------------|------------|----------------------------|----------|-----------|--|
| GMS No./GR.SP.No.      |      | STATUS OF DRG           |     | TYPE OF PRODUCT |         | COMP. DRG. No.                    |     | M/C TOOL TRANS No. |            | REF. DRG. No.              |          |           |  |
| NCT                    |      | -Sd-                    |     | ST 660MW        |         | 01060256000                       |     | 274                |            | AS PER SKETCH              |          |           |  |
| AGREED DEPT.           |      | NAME                    |     | SIGN.           |         | DATE                              |     | DESIGN ORDER No.   |            | M/C MODEL No.              |          |           |  |
| NCT                    |      | ATUL                    |     | -Sd-            |         | 18.12.14                          |     | NC/ST-66/T/1451    |            | 7.5M CNC VERT. BOR.(1-032) |          |           |  |
| GRADE OF UNTOL. DIM.:- |      | M/CG- <del>L</del> /W/F |     | AA0230208       |         | WELDING-A/B/C/D                   |     | AA0621104          |            | GAS CUTTING-'T3'           |          | AA0621101 |  |
| REV                    | DATE | ALTERED                 | REV | DATE            | ALTERED | DEPT.                             | JTE | SCALE              | WEIGHT(Kg) | REF.TO ASSY. DRG.          | ITEM No. | OF        |  |
|                        |      | CHECKED                 |     |                 | CHECKED | 209                               |     | NTS                | ~2.1       |                            | No.      | ITEMS     |  |
|                        |      |                         |     |                 |         | TITLE                             |     | DRAWING No.        |            | REV                        |          |           |  |
|                        |      |                         |     |                 |         | R.H. CRANK FACE GROOVING TOOL W=6 |     | R2128-1425         |            |                            |          |           |  |
|                        |      |                         |     |                 |         | SHEET No.01                       |     | No. OF SHEETS      |            | 01                         |          |           |  |

INVENTORY No. SIGN.&DATE REF. DRG. No.

SIZE A 3



COPYRIGHT AND CONFIDENTIAL  
THE INFORMATION ON THIS DOCUMENT IS THE PROPERTY OF BHARAT  
HEAVY ELECTRICALS LIMITED. IT MUST NOT BE USED DIRECTLY  
OR INDIRECTLY IN ANY WAY DETRIMENTAL TO THE INTEREST OF COMPANY.

FIRST ANGLE PROJECTION

(ALL DIMENSIONS ARE IN mm)

FORM DG38(B)

3.2/  
THE REST

DRAWING No. R2128-1427

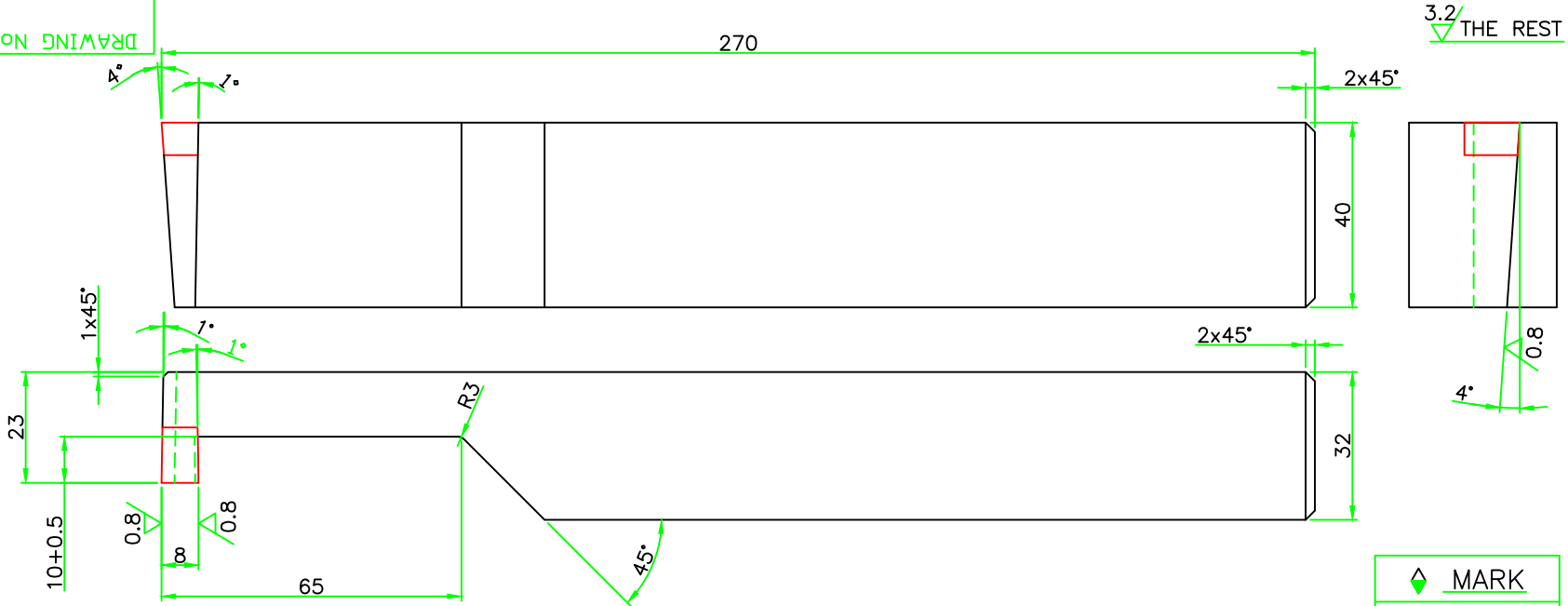

◇ MARK  
R2128-1427  
Ø750-Ø1820

NOTES:-

- 1-NON-CUTTING SHARP EDGES TO BE ROUNDED OFF.
- \*\*2-GROOVING INSERT (INDEXABLE COATED CARBIDE) FOR GROOVE TURN APPLICATION IS TO BE USED.
- \*\*3-INSERT AND ITS CLAMPING ARRANGEMENT SHOULD BE POSITIVE TYPE SCREW CLAMPING TO BE DECIDED BY VENDOR SUITABLE FOR VIBRATION FREE & PRECISION FACE GROOVING ON ALLOY STEEL CASTINGS ON BORE DIA Ø750-Ø1820.
- \*4-ANY STEEL HAVING MINIMUM TENSILE STRENGTH 75Kg/mm<sup>2</sup>
- 5-VENDOR TO PROVIDE DETAILS OF GROOVING INSERT AND OTHER CONSUMABLE/SPARES LIKE SCREW,CLAMP,SHIMS ETC.
- 6-ACCEPTANCE OF TOOL ONLY AFTER SUCCESSFUL TRIAL MACHINING ON CUTTING SPEED=50 METER/MINUTE AND FEED=0.1 MM/REV. IN SHOP.
- 7-CONSERVATION TO BE DONE AS PER TL-30007.

| ITEM No. | DESCRIPTION | UNIT | DRAWING No. | MATERIAL CODE | A               | UNIT | UNIT WEIGHT |
|----------|-------------|------|-------------|---------------|-----------------|------|-------------|
|          |             |      |             | VAR.          | MATERIAL SPECN. | c    | QTY.        |
| 02       | INSERT      |      |             | **            |                 |      | --          |
|          |             |      |             |               |                 |      | 01          |
| 01       | SHANK       |      |             | *             |                 |      | --          |
|          |             |      |             |               |                 |      | 01          |

INVENTORY No. SIGN.&DATE REF. DRG. No.

|                                   |  |               |  |                 |  |                |  |                    |  |                            |  |
|-----------------------------------|--|---------------|--|-----------------|--|----------------|--|--------------------|--|----------------------------|--|
| GMS No./GR.SP.No.                 |  | STATUS OF DRG |  | TYPE OF PRODUCT |  | COMP. DRG. No. |  | M/C TOOL TRANS No. |  | REF. DRG. No.              |  |
|                                   |  |               |  | ST 800MW        |  | 01060258000    |  | 274                |  | AS PER SKETCH              |  |
| AGREED DEPT.                      |  | NAME          |  | SIGN.           |  | DATE           |  | DESIGN ORDER No.   |  | M/C MODEL No.              |  |
| NCT                               |  | ATUL          |  | -Sd-            |  | 18.12.14       |  | NC/ST-80/T/1453    |  | 7.5M CNC VERT. BOR.(1-032) |  |
| GRADE OF UNTOL. DIM.:-            |  |               |  | DRN             |  | NAME           |  | SIGN.              |  | DATE                       |  |
| M/CG- <del>L</del> /W/F AA0230208 |  |               |  | CHD             |  | G.SHAYAM       |  | -Sd-               |  | 18.12.14                   |  |
| WELDING-A/B/C/D AA0621104         |  |               |  | APD             |  | ANKUR          |  | -Sd-               |  | 18.12.14                   |  |
| GAS CUTTING-'T3' AA0621101        |  |               |  | REV             |  | DATE           |  | ALTERED            |  | No. OF VAR.                |  |
| REV                               |  | DATE          |  | REV             |  | DATE           |  | CHECKED            |  | No. OF ITEMS               |  |
|                                   |  |               |  |                 |  |                |  |                    |  |                            |  |
| DEPT. JTE                         |  |               |  | SCALE           |  | WEIGHT(Kg)     |  | REF.TO ASSY. DRG.  |  | ITEM No.                   |  |
| CODE 209                          |  |               |  | NTS             |  | ~2.1           |  |                    |  | No.                        |  |
| TITLE                             |  |               |  | DRAWING No.     |  | REV            |  |                    |  |                            |  |
| R.H. CRANK FACE GROOVING TOOL W=8 |  |               |  | R2128-1427      |  |                |  |                    |  |                            |  |
| SHEET No.01                       |  |               |  | No. OF SHEETS   |  | 01             |  |                    |  |                            |  |

SIZE A 3

COPYRIGHT AND CONFIDENTIAL  
THE INFORMATION ON THIS DOCUMENT IS THE PROPERTY OF BHARAT  
HEAVY ELECTRICALS LIMITED. IT MUST NOT BE USED DIRECTLY  
OR INDIRECTLY IN ANY WAY DETRIMENTAL TO THE INTEREST OF COMPANY.

FIRST ANGLE PROJECTION

(ALL DIMENSIONS ARE IN mm)

FORM DG38(B)

3.2  
✓ THE REST

DRAWING No. R2128-1428

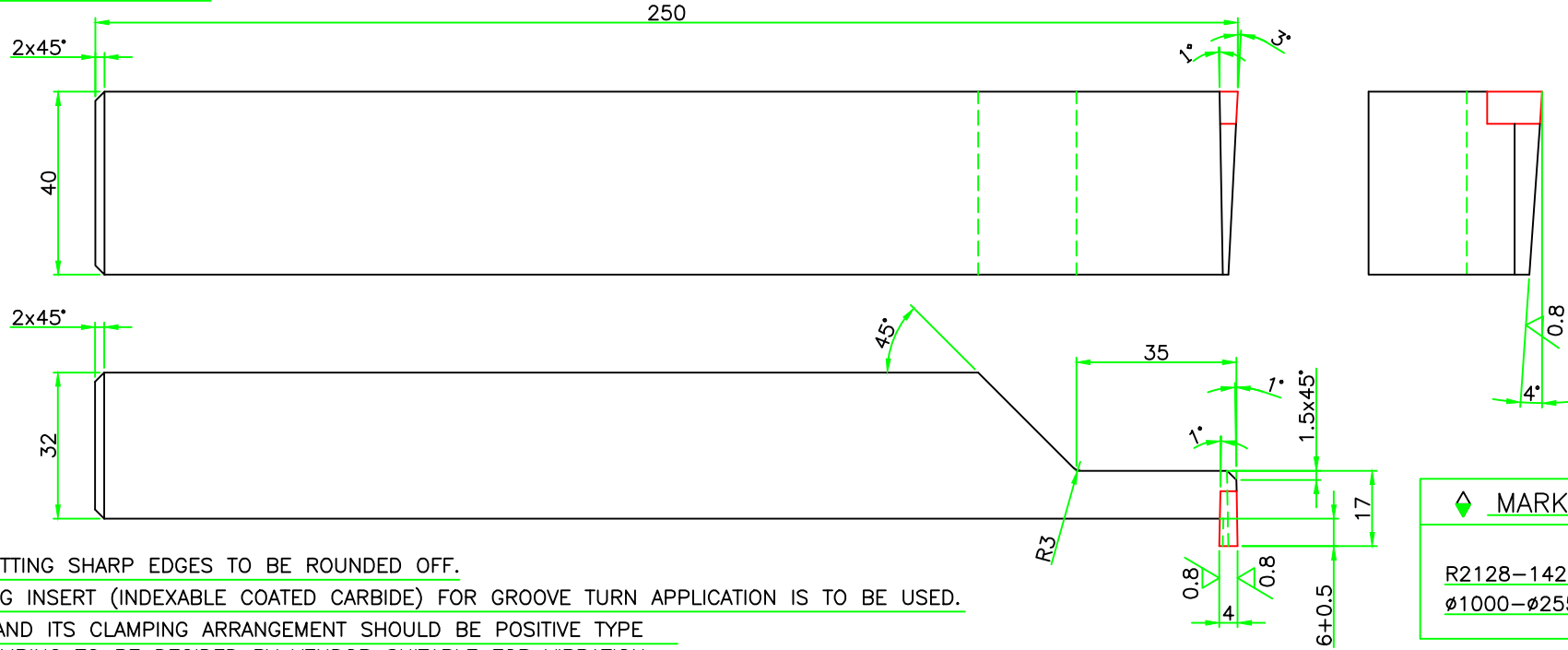

NOTES:-

- 1-NON-CUTTING SHARP EDGES TO BE ROUNDED OFF.
- \*\*2-GROOVING INSERT (INDEXABLE COATED CARBIDE) FOR GROOVE TURN APPLICATION IS TO BE USED.
- \*\*3-INSERT AND ITS CLAMPING ARRANGEMENT SHOULD BE POSITIVE TYPE SCREW CLAMPING TO BE DECIDED BY VENDOR SUITABLE FOR VIBRATION FREE & PRECISION FACE GROOVING ON ALLOY STEEL CASTINGS ON BORE DIA  $\phi 1000-\phi 2550$ .
- \*4-ANY STEEL HAVING MINIMUM TENSILE STRENGTH 75Kg/mm<sup>2</sup>
- 5-VENDOR TO PROVIDE DETAILS OF GROOVING INSERT AND OTHER CONSUMABLE/SPARES LIKE SCREW,CLAMP,SHIMS ETC.
- 6-ACCEPTANCE OF TOOL ONLY AFTER SUCCESSFUL TRIAL MACHINING ON CUTTING SPEED=50 METER/MINUTE AND FEED=0.1 MM/REV. IN SHOP.
- 7-CONSERVATION TO BE DONE AS PER TL-30007.

◇ MARK  
R2128-1428  
 $\phi 1000-\phi 2550$

|          |             |     |             |                      |        |             |
|----------|-------------|-----|-------------|----------------------|--------|-------------|
| 02       | INSERT      |     |             | **                   |        | --          |
| 01       | SHANK       |     |             | *                    |        | 01          |
| ITEM No. | DESCRIPTION | STD | DRAWING No. | MATERIAL CODE        | A UNIT | UNIT WEIGHT |
|          |             |     |             | VAR. MATERIAL SPECN. | C      | QTY.        |

|                           |  |                                   |       |                                   |                  |  |                   |
|---------------------------|--|-----------------------------------|-------|-----------------------------------|------------------|--|-------------------|
| GMS No./GR.SP.No.         |  | STATUS OF DRG                     |       | TYPE OF PRODUCT                   | COMP. DRG. No.   | M/C TOOL TRANS No.                       | REF. DRG. No.     |
| AGREED DEPT.              |  | NAME                              | SIGN. | DATE                              | ST 660MW         | 0112156000                               | 274               |
| NCT                       |  | ATUL                              | -Sd-  | 19.12.14                          | DESIGN ORDER No. | M/C MODEL No.                            | AS PER SKETCH     |
| GRADE OF UNTOL. DIM.:-    |  | M/CG- <del>L</del> /W/F AA0230208 |       | NC/ST-66/T/1454                   |                  | 7.5M CNC VERT. BOR.(1-032)               |                   |
| WELDING-A/B/C/D AA0621104 |  | GAS CUTTING-'T3' AA0621101        |       | BH&EL                             |                  | BHARAT HEAVY ELECTRICALS LTD.<br>HARDWAR |                   |
| REV DATE ALTERED CHECKED  |  | REV DATE ALTERED CHECKED          |       | DEPT. JTE                         | SCALE            | WEIGHT(Kg)                               | REF.TO ASSY. DRG. |
|                           |  |                                   |       | CODE 209                          | NTS              | ~2.1                                     | ITEM No. OF ITEMS |
|                           |  |                                   |       | TITLE                             |                  | DRAWING No.                              | REV               |
|                           |  |                                   |       | L.H. CRANK FACE GROOVING TOOL W=4 |                  | R2128-1428                               |                   |
|                           |  |                                   |       | SHEET No.01                       |                  | No. OF SHEETS 01                         |                   |

SIZE A 3

INVENTORY No. SIGN.&DATE REF. DRG. No.

COPYRIGHT AND CONFIDENTIAL  
THE INFORMATION ON THIS DOCUMENT IS THE PROPERTY OF BHARAT  
HEAVY ELECTRICALS LIMITED. IT MUST NOT BE USED DIRECTLY  
OR INDIRECTLY IN ANY WAY DETRIMENTAL TO THE INTEREST OF COMPANY.

FIRST ANGLE PROJECTION

(ALL DIMENSIONS ARE IN mm)

FORM DG38(B)

3.2/  
THE REST

DRAWING No. R2128-1429

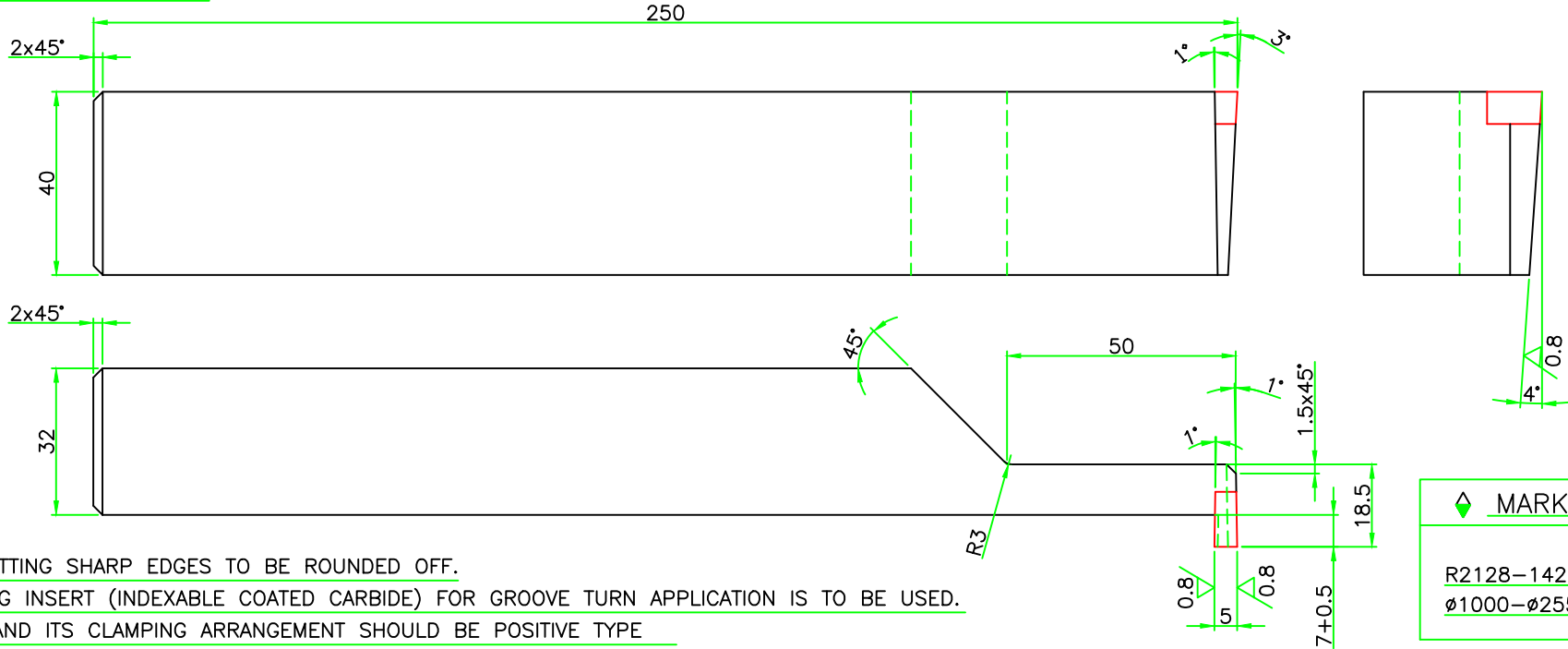

NOTES:-

- 1-NON-CUTTING SHARP EDGES TO BE ROUNDED OFF.
- \*\*2-GROOVING INSERT (INDEXABLE COATED CARBIDE) FOR GROOVE TURN APPLICATION IS TO BE USED.
- \*\*3-INSERT AND ITS CLAMPING ARRANGEMENT SHOULD BE POSITIVE TYPE  
SCREW CLAMPING TO BE DECIDED BY VENDOR SUITABLE FOR VIBRATION  
FREE & PRECISION FACE GROOVING ON ALLOY STEEL CASTINGS ON BORE  
DIA ø1000-ø2550.
- \*4-ANY STEEL HAVING MINIMUM TENSILE STRENGTH 75Kg/mm<sup>2</sup>
- 5-VENDOR TO PROVIDE DETAILS OF GROOVING INSERT AND OTHER  
CONSUMABLE/SPARES LIKE SCREW,CLAMP,SHIMS ETC.
- 6-ACCEPTANCE OF TOOL ONLY AFTER SUCCESSFUL TRIAL MACHINING ON  
CUTTING SPEED=50 METER/MINUTE AND FEED=0.1 MM/REV. IN SHOP.
- 7-CONSERVATION TO BE DONE AS PER TL-30007.

|          |             |     |             |                      |        |             |
|----------|-------------|-----|-------------|----------------------|--------|-------------|
| 02       | INSERT      |     |             | **                   |        | --          |
| 01       | SHANK       |     |             | *                    |        | 01          |
| ITEM No. | DESCRIPTION | STD | DRAWING No. | MATERIAL CODE        | A UNIT | UNIT WEIGHT |
|          |             |     |             | VAR. MATERIAL SPECN. | C      | QTY.        |

|                   |               |                 |                |                    |  |
|-------------------|---------------|-----------------|----------------|--------------------|--|
| GMS No./GR.SP.No. | STATUS OF DRG | TYPE OF PRODUCT | COMP. DRG. No. | M/C TOOL TRANS No. | REF. DRG. No.                            |
| AGREED DEPT.      | NAME          | SIGN.           | DATE           | ST 700MW           | 0112151000                               |
| NCT               | ATUL          | -Sd-            | 19.12.14       |                    | 274                                      |
|                   |               |                 |                |                    | AS PER SKETCH                            |
|                   |               |                 |                |                    | DESIGN ORDER No. NC/ST-70/T/1455         |
|                   |               |                 |                |                    | M/C MODEL No. 7.5M CNC VERT. BOR.(1-032) |

|                                   |
|-----------------------------------|
| GRADE OF UNTOL. DIM.:-            |
| M/CG- <del>L</del> /W/F AA0230208 |
| WELDING-A/B/C/D AA0621104         |
| GAS CUTTING-'T3' AA0621101        |

|      |                               |          |          |             |          |
|------|-------------------------------|----------|----------|-------------|----------|
| BHEL | BHARAT HEAVY ELECTRICALS LTD. |          |          | No. OF VAR. |          |
|      | DRN                           | G.SHAYAM | -Sd-     |             | 19.12.14 |
|      | CHD                           | RAVI     | -Sd-     |             | 19.12.14 |
| APD  | ANKUR                         | -Sd-     | 19.12.14 |             |          |

|     |      |         |     |      |         |       |     |       |            |                   |             |
|-----|------|---------|-----|------|---------|-------|-----|-------|------------|-------------------|-------------|
| REV | DATE | ALTERED | REV | DATE | ALTERED | DEPT. | JTE | SCALE | WEIGHT(Kg) | REF.TO ASSY. DRG. | ITEM No. OF |
|     |      | CHECKED |     |      | CHECKED |       | 209 | NTS   | ~2.1       |                   | No. OF      |

|                                   |             |     |
|-----------------------------------|-------------|-----|
| TITLE                             | DRAWING No. | REV |
| L.H. CRANK FACE GROOVING TOOL W=5 | R2128-1429  |     |

SHEET No.01 | No. OF SHEETS 01

SIZE A 3

INVENTORY No. SIGN.&DATE REF. DRG. No.

COPYRIGHT AND CONFIDENTIAL  
 THE INFORMATION ON THIS DOCUMENT IS THE PROPERTY OF BHARAT  
 HEAVY ELECTRICALS LIMITED. IT MUST NOT BE USED DIRECTLY  
 OR INDIRECTLY IN ANY WAY DETRIMENTAL TO THE INTEREST OF COMPANY.

FIRST ANGLE PROJECTION

(ALL DIMENSIONS ARE IN mm)

FORM DG38(B)

3.2/  
THE REST

DRAWING No. R2128-1430

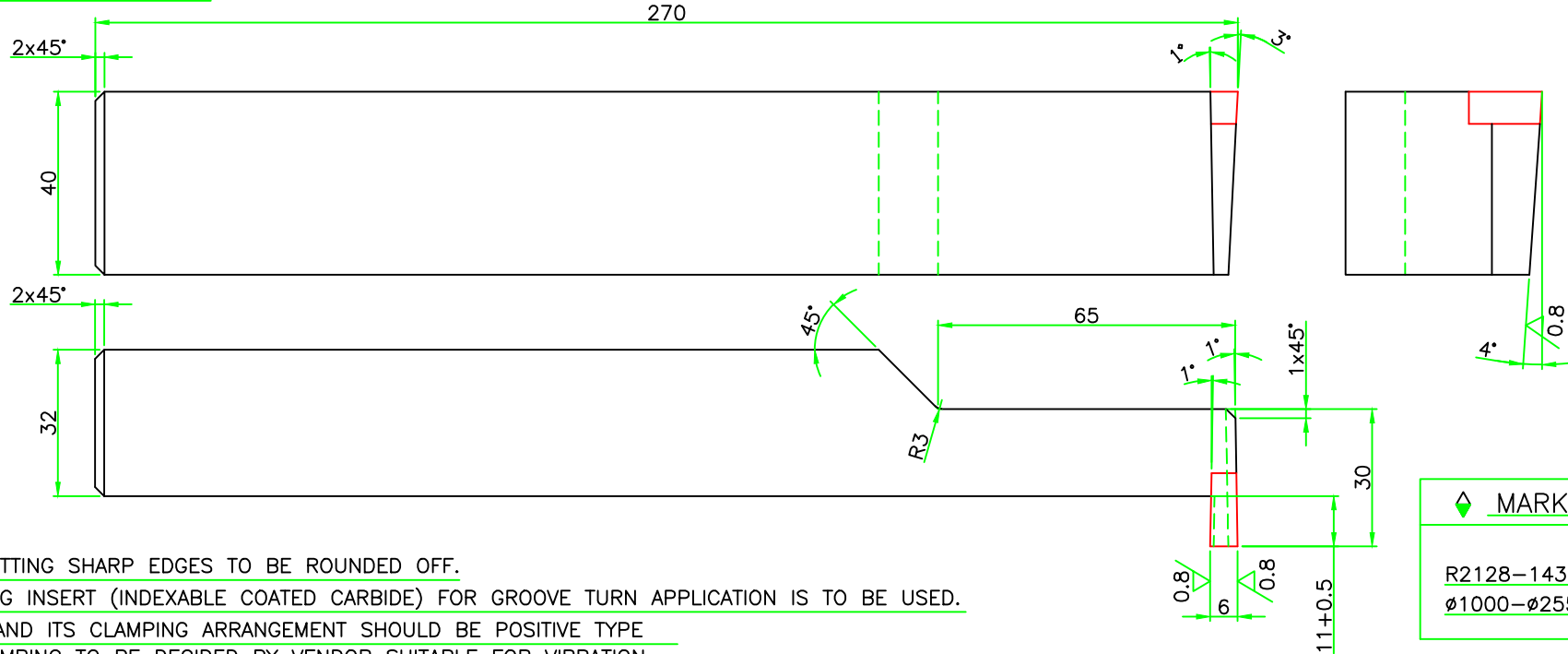

MARK  
 R2128-1430  
 ø1000-ø2550

NOTES:-

- 1-NON-CUTTING SHARP EDGES TO BE ROUNDED OFF.
- \*\*2-GROOVING INSERT (INDEXABLE COATED CARBIDE) FOR GROOVE TURN APPLICATION IS TO BE USED.
- \*\*3-INSERT AND ITS CLAMPING ARRANGEMENT SHOULD BE POSITIVE TYPE SCREW CLAMPING TO BE DECIDED BY VENDOR SUITABLE FOR VIBRATION FREE & PRECISION FACE GROOVING ON ALLOY STEEL CASTINGS ON BORE DIA ø1000-ø2550.
- \*4-ANY STEEL HAVING MINIMUM TENSILE STRENGTH 75Kg/mm<sup>2</sup>
- 5-VENDOR TO PROVIDE DETAILS OF GROOVING INSERT AND OTHER CONSUMABLE/SPARES LIKE SCREW,CLAMP,SHIMS ETC.
- 6-ACCEPTANCE OF TOOL ONLY AFTER SUCCESSFUL TRIAL MACHINING ON CUTTING SPEED=50 METER/MINUTE AND FEED=0.1 MM/REV. IN SHOP.
- 7-CONSERVATION TO BE DONE AS PER TL-30007.

| ITEM No. | DESCRIPTION | STD | DRAWING No. | MATERIAL CODE | A               | UNIT | UNIT WEIGHT |
|----------|-------------|-----|-------------|---------------|-----------------|------|-------------|
|          |             |     |             | VAR.          | MATERIAL SPECN. | C    | QTY.        |
| 02       | INSERT      |     |             | **            |                 |      | --          |
|          |             |     |             |               |                 |      | 01          |
| 01       | SHANK       |     |             | *             |                 |      | --          |
|          |             |     |             |               |                 |      | 01          |

| GMS No./GR.SP.No.                 |             | STATUS OF DRG |            | TYPE OF PRODUCT   | COMP. DRG. No.                   | M/C TOOL TRANS No.                       | REF. DRG. No. |       |             |         |                                   |                   |             |          |         |          |      |  |       |      |          |  |  |       |      |          |  |
|-----------------------------------|-------------|---------------|------------|---|----------------------------------|--|---------------|-------|-------------|---------|-----------------------------------|-------------------|-------------|----------|---------|----------|------|--|-------|------|----------|--|--|-------|------|----------|--|
| AGREED DEPT.                      | NAME        | SIGN.         | DATE       | ST 800MW  | 0112158000                       | 274                                      | AS PER SKETCH |       |             |         |                                   |                   |             |          |         |          |      |  |       |      |          |  |  |       |      |          |  |
| NCT                               | ATUL        | -Sd-          | 19.12.14   |   | DESIGN ORDER No. NC/ST-80/T/1456 | M/C MODEL No. 7.5M CNC VERT. BOR.(1-032) |               |       |             |         |                                   |                   |             |          |         |          |      |  |       |      |          |  |  |       |      |          |  |
| GRADE OF UNTOL. DIM.:-            |             |               |            | <table border="1"> <thead> <tr> <th>DRN</th> <th>NAME</th> <th>SIGN.</th> <th>DATE</th> <th>No. OF VAR.</th> </tr> </thead> <tbody> <tr> <td></td> <td>G.SHAYAM</td> <td>-Sd-</td> <td>19.12.14</td> <td></td> </tr> <tr> <td></td> <td>RAVI</td> <td>-Sd-</td> <td>19.12.14</td> <td></td> </tr> <tr> <td></td> <td>ANKUR</td> <td>-Sd-</td> <td>19.12.14</td> <td></td> </tr> </tbody> </table> |                                  |  |               | DRN   | NAME        | SIGN.   | DATE                              | No. OF VAR.       |             | G.SHAYAM | -Sd-    | 19.12.14 |      |  | RAVI  | -Sd- | 19.12.14 |  |  | ANKUR | -Sd- | 19.12.14 |  |
| DRN                               | NAME        | SIGN.         | DATE       | No. OF VAR.   |                                  |  |               |       |             |         |                                   |                   |             |          |         |          |      |  |       |      |          |  |  |       |      |          |  |
|                                   | G.SHAYAM    | -Sd-          | 19.12.14   |   |                                  |  |               |       |             |         |                                   |                   |             |          |         |          |      |  |       |      |          |  |  |       |      |          |  |
|                                   | RAVI        | -Sd-          | 19.12.14   |   |                                  |  |               |       |             |         |                                   |                   |             |          |         |          |      |  |       |      |          |  |  |       |      |          |  |
|                                   | ANKUR       | -Sd-          | 19.12.14   |   |                                  |  |               |       |             |         |                                   |                   |             |          |         |          |      |  |       |      |          |  |  |       |      |          |  |
| M/CG- <del>L</del> /W/F AA0230208 |             |               |            | <table border="1"> <thead> <tr> <th>DEPT.</th> <th>JTE</th> <th>SCALE</th> <th>WEIGHT(Kg)</th> <th>REF.TO ASSY. DRG.</th> <th>ITEM No. OF</th> </tr> </thead> <tbody> <tr> <td></td> <td>209</td> <td>NTS</td> <td>~2.1</td> <td></td> <td>ITEMS</td> </tr> </tbody> </table>   |                                  |  |               | DEPT. | JTE         | SCALE   | WEIGHT(Kg)                        | REF.TO ASSY. DRG. | ITEM No. OF |          | 209     | NTS      | ~2.1 |  | ITEMS |      |          |  |  |       |      |          |  |
| DEPT.                             | JTE         | SCALE         | WEIGHT(Kg) | REF.TO ASSY. DRG.   | ITEM No. OF                      |  |               |       |             |         |                                   |                   |             |          |         |          |      |  |       |      |          |  |  |       |      |          |  |
|                                   | 209         | NTS           | ~2.1       |   | ITEMS                            |  |               |       |             |         |                                   |                   |             |          |         |          |      |  |       |      |          |  |  |       |      |          |  |
| WELDING-A/B/C/D AA0621104         |             |               |            | <table border="1"> <thead> <tr> <th>REV</th> <th>DATE</th> <th>ALTERED</th> <th>CHECKED</th> <th>REV</th> <th>DATE</th> <th>ALTERED</th> <th>CHECKED</th> </tr> </thead> <tbody> <tr> <td></td> <td></td> <td></td> <td></td> <td></td> <td></td> <td></td> <td></td> </tr> </tbody> </table>   |                                  |  |               | REV   | DATE        | ALTERED | CHECKED                           | REV               | DATE        | ALTERED  | CHECKED |          |      |  |       |      |          |  |  |       |      |          |  |
| REV                               | DATE        | ALTERED       | CHECKED    | REV   | DATE                             | ALTERED                                  | CHECKED       |       |             |         |                                   |                   |             |          |         |          |      |  |       |      |          |  |  |       |      |          |  |
|                                   |             |               |            |   |                                  |  |               |       |             |         |                                   |                   |             |          |         |          |      |  |       |      |          |  |  |       |      |          |  |
| GAS CUTTING-'T3' AA0621101        |             |               |            | <table border="1"> <thead> <tr> <th>TITLE</th> <th>DRAWING No.</th> <th>REV</th> </tr> </thead> <tbody> <tr> <td>L.H. CRANK FACE GROOVING TOOL W=6</td> <td>R2128-1430</td> <td></td> </tr> </tbody> </table>   |                                  |  |               | TITLE | DRAWING No. | REV     | L.H. CRANK FACE GROOVING TOOL W=6 | R2128-1430        |             |          |         |          |      |  |       |      |          |  |  |       |      |          |  |
| TITLE                             | DRAWING No. | REV           |            |   |                                  |  |               |       |             |         |                                   |                   |             |          |         |          |      |  |       |      |          |  |  |       |      |          |  |
| L.H. CRANK FACE GROOVING TOOL W=6 | R2128-1430  |               |            |   |                                  |  |               |       |             |         |                                   |                   |             |          |         |          |      |  |       |      |          |  |  |       |      |          |  |
| SHEET No. 01                      |             |               |            | No. OF SHEETS 01  |                                  |  |               |       |             |         |                                   |                   |             |          |         |          |      |  |       |      |          |  |  |       |      |          |  |

SIZE A 3

INVENTORY No. SIGN.&DATE REF. DRG. No.

COPYRIGHT AND CONFIDENTIAL  
THE INFORMATION ON THIS DOCUMENT IS THE PROPERTY OF BHARAT  
HEAVY ELECTRICALS LIMITED. IT MUST NOT BE USED DIRECTLY  
OR INDIRECTLY IN ANY WAY DETRIMENTAL TO THE INTEREST OF COMPANY.

FIRST ANGLE PROJECTION

(ALL DIMENSIONS ARE IN mm)

FORM DG38(B)

DRAWING No. R2128-1431

3.2  
✓ THE REST

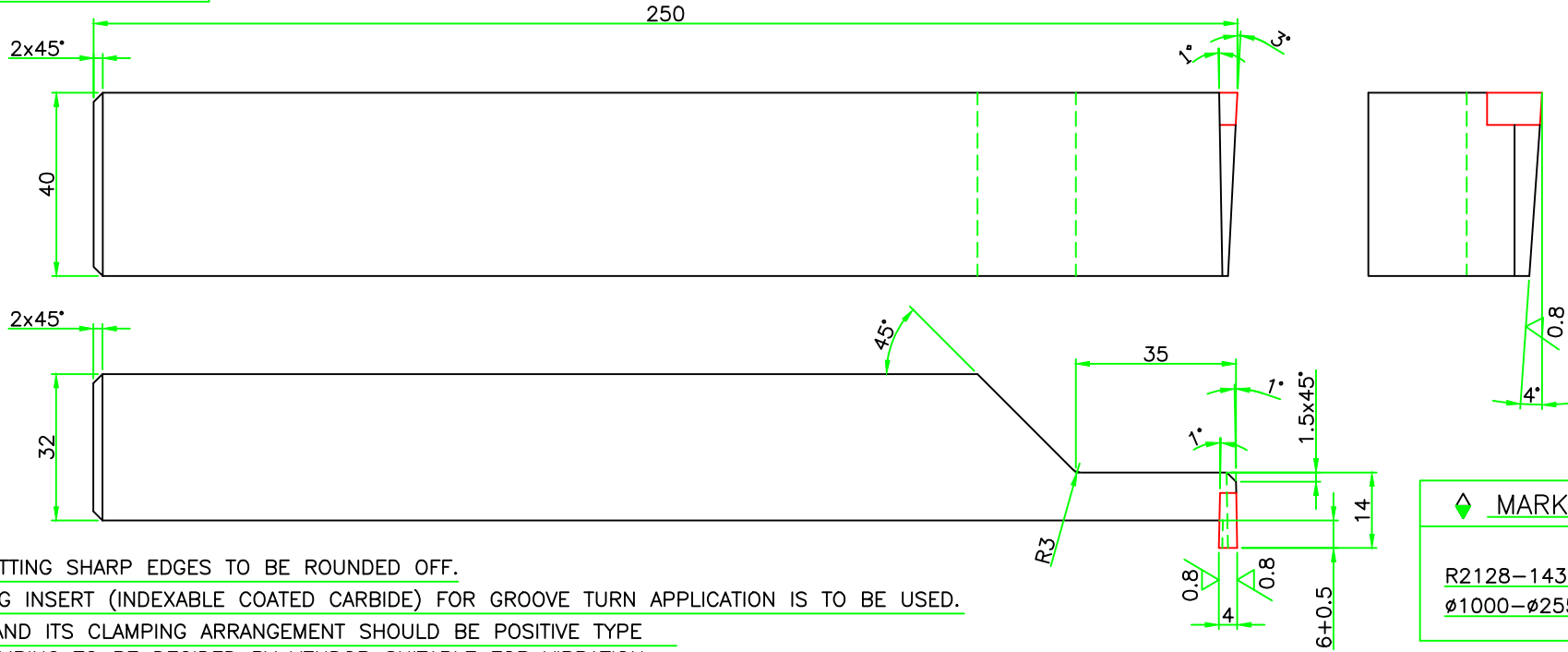

MARK  
R2128-1431  
Ø1000-Ø2550

NOTES:-

- 1-NON-CUTTING SHARP EDGES TO BE ROUNDED OFF.
- \*\*2-GROOVING INSERT (INDEXABLE COATED CARBIDE) FOR GROOVE TURN APPLICATION IS TO BE USED.
- \*\*3-INSERT AND ITS CLAMPING ARRANGEMENT SHOULD BE POSITIVE TYPE SCREW CLAMPING TO BE DECIDED BY VENDOR SUITABLE FOR VIBRATION FREE & PRECISION FACE GROOVING ON ALLOY STEEL CASTINGS ON BORE DIA Ø1000-Ø2550.
- \*4-ANY STEEL HAVING MINIMUM TENSILE STRENGTH 75Kg/mm<sup>2</sup>
- 5-VENDOR TO PROVIDE DETAILS OF GROOVING INSERT AND OTHER CONSUMABLE/SPARES LIKE SCREW,CLAMP,SHIMS ETC.
- 6-ACCEPTANCE OF TOOL ONLY AFTER SUCCESSFUL TRIAL MACHINING ON CUTTING SPEED=50 METER/MINUTE AND FEED=0.1 MM/REV. IN SHOP.
- 7-CONSERVATION TO BE DONE AS PER TL-30007.

|          |             |     |             |                      |        |             |
|----------|-------------|-----|-------------|----------------------|--------|-------------|
| 02       | INSERT      |     |             | **                   |        | --          |
| 01       | SHANK       |     |             | *                    |        | --          |
| ITEM No. | DESCRIPTION | STD | DRAWING No. | MATERIAL CODE        | A UNIT | UNIT WEIGHT |
|          |             |     |             | VAR. MATERIAL SPECN. | C      | QTY.        |

|                              |               |                 |                                  |  |               |
|------------------------------|---------------|-----------------|----------------------------------|--|---------------|
| GMS No./GR.SP.No.            | STATUS OF DRG | TYPE OF PRODUCT | COMP. DRG. No.                   | M/C TOOL TRANS No.                       | REF. DRG. No. |
| AGREED DEPT. NAME SIGN. DATE |               | ST 800MW        | 0112158000                       | 274                                      | AS PER SKETCH |
| NCT K.R. YADAV -Sd- 24.12.14 |               |                 | DESIGN ORDER No. NC/ST-80/T/1459 | M/C MODEL No. 7.5M CNC VERT. BOR.(1-032) |               |

|                                   |
|-----------------------------------|
| GRADE OF UNTOL. DIM.:-            |
| M/CG- <del>L</del> /W/F AA0230208 |
| WELDING-A/B/C/D AA0621104         |
| GAS CUTTING-'T3' AA0621101        |

|      |                               |          |            |             |               |
|------|-------------------------------|----------|------------|-------------|---------------|
| BHEL | BHARAT HEAVY ELECTRICALS LTD. |          |            | No. OF VAR. |               |
|      | DRN                           | G.SHAYAM | SIGN. -Sd- |             | DATE 24.12.14 |
|      | CHD                           | RAVI     | -Sd-       |             | 24.12.14      |
| APD  | ANKUR                         | -Sd-     | 24.12.14   |             |               |

|     |      |         |     |      |         |                                   |                  |            |                   |             |
|-----|------|---------|-----|------|---------|-----------------------------------|------------------|------------|-------------------|-------------|
| REV | DATE | ALTERED | REV | DATE | ALTERED | DEPT. JTE                         | SCALE            | WEIGHT(Kg) | REF.TO ASSY. DRG. | ITEM No. OF |
|     |      | CHECKED |     |      | CHECKED | 209                               | NTS              | ~2.1       |                   | No. ITEMS   |
|     |      |         |     |      |         | TITLE                             | DRAWING No.      |            | REV               |             |
|     |      |         |     |      |         | L.H. CRANK FACE GROOVING TOOL W=4 | R2128-1431       |            |                   |             |
|     |      |         |     |      |         | SHEET No.01                       | No. OF SHEETS 01 |            |                   |             |

SIZE A 3