



**Packaging Instructions for Piping
Components**



Doc. No
PC: PKG:01
Rev No: 00
Date : 28 /05/ 2014

No of Sheets : 24

**PACKAGING INSTRUCTIONS FOR PIPING COMPONENTS
PC: PKG: 01**

Revision summary

| Rev No | Revision Details | Issued on |
|--------|------------------|------------|
| 00 | Fresh issue | 28-05-2014 |
| | | |
| | | |
| | | |
| | | |
| | | |
| | | |
| | | |

| Prepared by | Reviewed & Approved by |
|---|--|
|  |  |
| S.ARUN KUMAR | K.VEDAPRASAD |



**Packaging Instructions for Piping
Components**

Doc. No
PC: PKG:01
Rev No: 00
Date : 28 /05/ 2014

No of Sheets : 24

Contents

1. Scope
2. Packaging
3. Criteria for Selection of Packaging
4. Types of packaging
5. Sling protections
6. Marking and Labelling
7. Packing list
8. General Instructions for packaging
9. Reference drawings
10. Cautionary symbols
11. Packing reference table
12. Check list



**Packaging Instructions for Piping
Components**

Doc. No
PC: PKG:01
Rev No: 00
Date : 28 /05/ 2014

No of Sheets : 24

1. SCOPE

This procedure elicits the general requirements to be complied with for packaging of piping components. The packaging is intended to preserve and protect the contents.

The handling, storage, cleaning, packaging, and preservation of items shall be controlled to prevent damage or loss and to minimize deterioration.

2. PACKAGING

This procedure contains requirements for packaging of items for protection against corrosion, contamination, physical damage, or any effect that would lower the quality or cause the components to deteriorate during the time they are shipped and stored at sites.

Items shall be inspected for cleanliness immediately before packaging. Dirt, oil, residue, metal chips or other forms of contamination shall be removed.

Adequate protection shall be provided against mechanical damage and atmospheric corrosion in transit and, for equipment suitable for outside storage, for prolonged storage at the site prior to installation.

Water proof barrier material – high density polythene shall be used as a resistant to grease and water; it shall protect items from airborne and windblown soils.

Desiccants like silica gel to be used inside pipe components. Silica gel shall conform to IS 3401. The gel is to be packed in sachets placed at different positions inside the components for absorbing moisture. The quantity of silica gel shall be adequate for storage period of one year.

Components to be placed in such a way that metal to metal contact is avoided.

For mechanical components, (1) all openings shall be covered or plugged with substantial (1/2 inch minimum thick) one piece plywood or metal closures, securely fastened and suitable for prolonged exposure prior to final installation; (2) all tapped openings in equipment shall be plugged with plastic plugs to protect internal threads; and (3) all welding end connections shall be provided with adequate weld bevel protectors to protect from corrosion and physical damage.



Packaging Instructions for Piping Components

Doc. No
PC: PKG:01
Rev No: 00
Date : 28 /05/ 2014

No of Sheets : 24

Austenitic stainless steel and nickel-based alloy materials shall be handled in such a manner that they are not in direct contact with carbon steel materials or with materials containing halogen, sulphur, zinc and lead.

Each components/item of stainless steel materials should be wrapped with high density polythene.

All equipment shall be packed, securely anchored (skid mounted when required) and weather protected for the shipment method adopted.

Temporary bracing or supports, marked and tagged for removal after equipment installation, shall be provided to prevent damage during shipment and shall be painted bright, fluorescent yellow.

3. Criteria for Selection of Packaging:

Packages are to be made according to categories listed in Table-6 (see page – 24), depending on the type of materials and size.

4. TYPES OF PACKAGING:

4.1 CRATES

- These are to be made of seasoned wood and are intended for packaging heavy materials Viz., straight pipes and pipes with attachments.
- The crates are to be lined with hi-density polythene, to prevent entry of moisture.
- The dimensions of the crates are to be restricted to 20 x5x5 feet.
- Pipes up to OD 350mm are to be crated.
- Pipes are to be stacked inside the crate so that the weight of the pipe does not rest on branch stubs or carrier plates.
- Contents of the crate should not come in contact with each other or with the crating, and should be adequately cushioned to preserve the painting.
- The gross weight of the crate should not exceed 2 Tons.
- For further instructions refer ASTM D6039 Standard Specification for Open and Covered wood Crates.

Packaging Instructions for Piping Components

Doc. No
PC: PKG:01
Rev No: 00
Date : 28 /05/ 2014

No of Sheets : 24

WOODEN CRATE

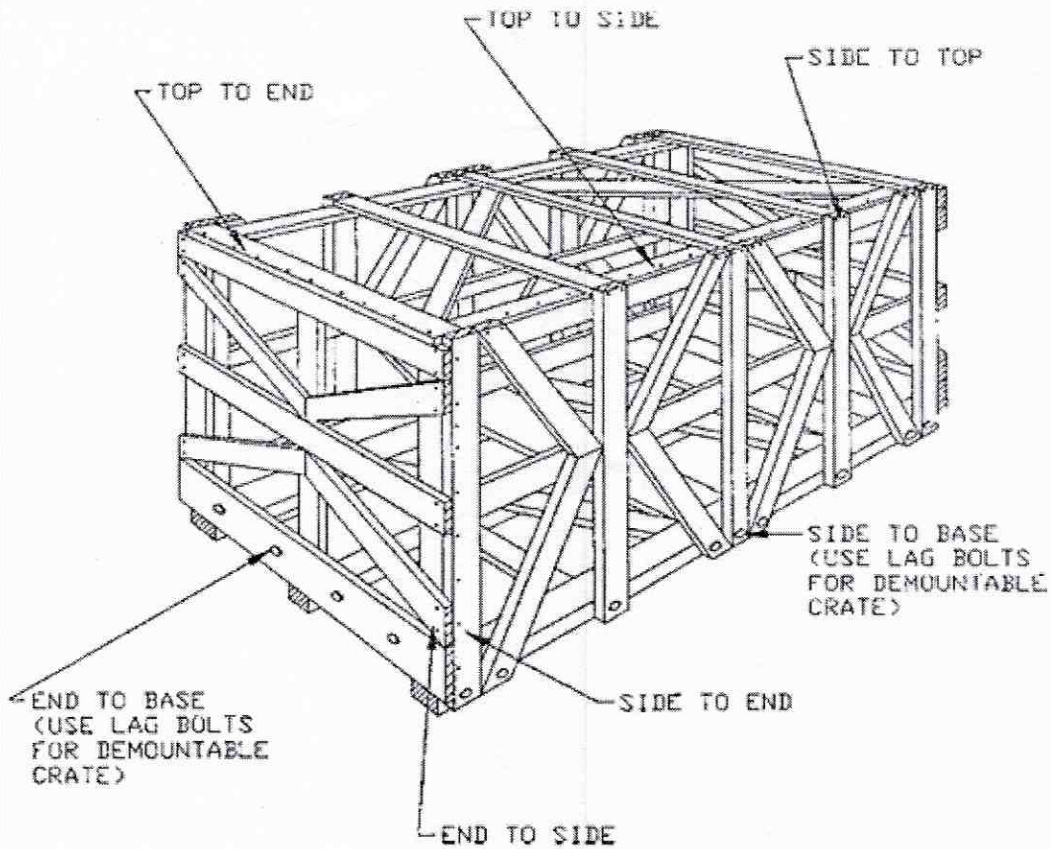

| Max Net Load (KGS) | Length (mm) | Width (mm) | Height (mm) |
|--------------------|-------------|------------|-------------|
| 2000 | 6096 | 1524 | 1524 |

All the dimensions shown in the above table are maximum inside dimensions.



**Packaging Instructions for Piping
Components**

Doc. No
PC: PKG:01

Rev No: 00
Date : 28 /05/ 2014

No of Sheets : 24

4.3 SADDLES

- Saddles are defined as profiled supports made of wood, and are used to cradle and support Tanks, pipe bends and pressure vessels.
- Ensure that the end chamfering of the bends are duly protected for the transit.
- Tanks are to be completely drained and dried.
- Adequate amount of the specified desiccant is to be placed inside the tank/ vessel.
- Ensure that all openings are covered and /or plugged.

4.4 CASES

- Other components such as fittings and Mitres are to be packed inside wooden cases.
- The insides of the cases are to be lined with hi-density polythene.
- Air vents to be provided in the cases for ventilation.
- Components to be placed in such a way that metal to metal contact is avoided.
- Small components like Fasteners, gaskets are to be packed in high density polythene covers and placed inside the wooden cases.
- Holes to be provided in the case floor to act as drains.

4.5 BUNDLES

- Bundles are transportable units where a large number of straight pipes of the same diameter and even lengths are arranged securely and are fit to be lifted by cranes and also stacked.
- Pipe ends should be covered fully with plastic end caps.
- Pipes can be bundled only when they can bear the stack compression load without additional support.
- Clamps made of wood or steel clamps with wooden inserts are to be used.
- Clamps must be locked firmly so that the pipes cannot slide out of bundle.
- Bundle must be held together by at least three sets of clamps as indicated in the diagram.



Packaging Instructions for Piping Components

Doc. No
PC: PKG:01
Rev No: 00
Date : 28 /05/ 2014

No of Sheets : 24

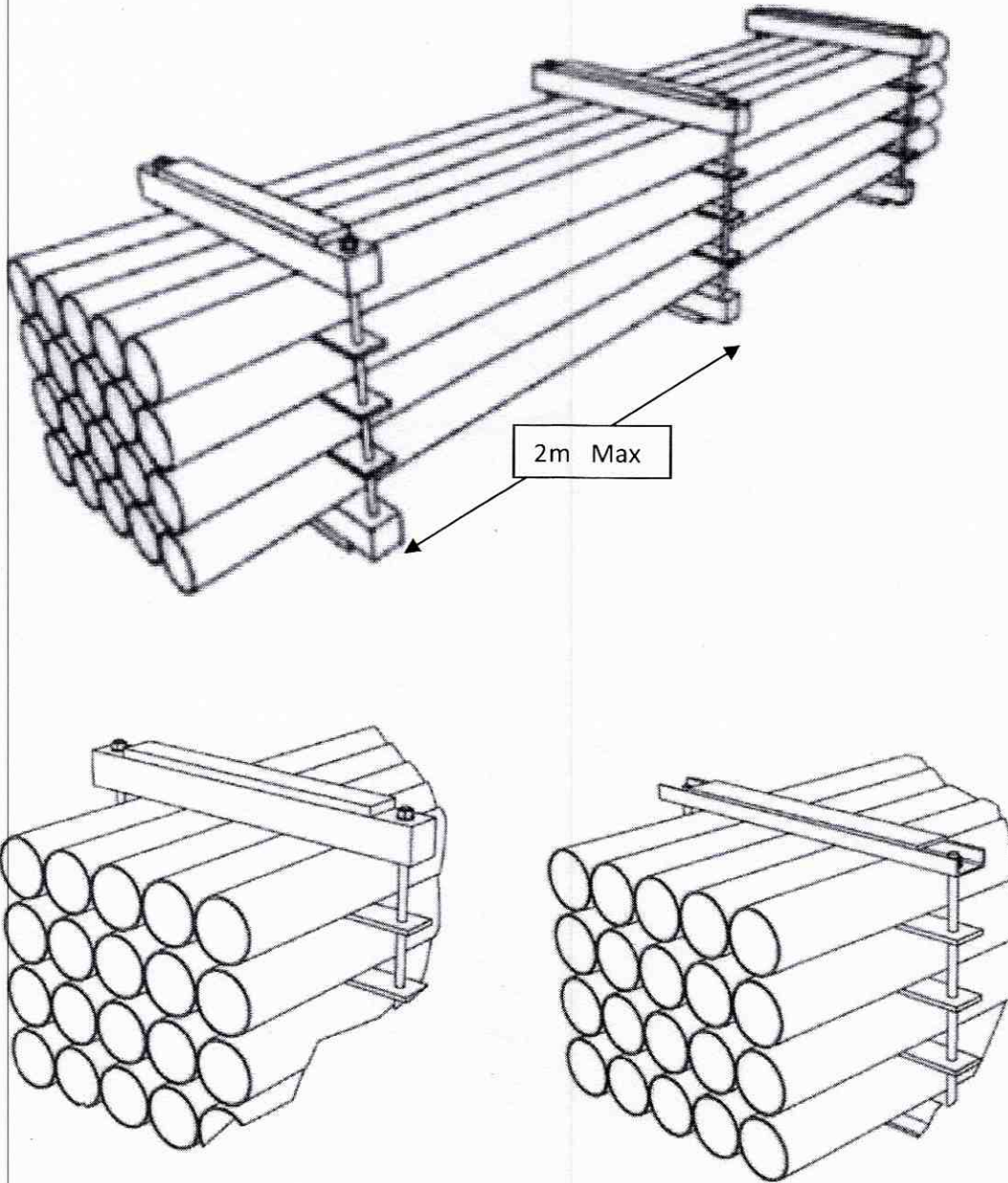



**Packaging Instructions for Piping
Components**

Doc. No
PC: PKG:01

Rev No: 00
Date : 28 /05/ 2014

No of Sheets : 24

5. SLING PROTECTIONS

The lifting points of the case or crate or bundle must be equipped with sling protections suitable to the respective package gross weight.

6. MARKING AND LABELLING

Components and their containers shall be identified by marking. Shipping marks shall be on all sides of package. The shipping marks shall be at least 3 inches high where space permits. Markings are to be in black paint or ink depending on shade of the package surface.

Cautionary symbols to be stencilled in red waterproof paint or ink.

7. PACKING LIST

One complete packing list inside a watertight envelope must be affixed outside of each package and be covered by sheet metal. One more copy of the packing slip wrapped in polyethylene bag is to be kept inside the box at the pertinent place.

| | | |
|---|-----------------------------------|---|
| Bharat Heavy Electricals Ltd., Piping Centre, Chennai – 600 017 | |  |
| Packaging Instructions for Piping Components | Doc. No PC: PKG:01 | |
| | Rev No: 00 Date : 28 /05/ 2014 | No of Sheets : 24 |

8. General Instructions for packaging

- The quantity of Slides / Runners is selected depending upon the weight and over-all dimension of the Load, to be carried. Table-1 and 2 details out the number of Slides, length and cross sections of the Slides to be provided with their carrying capacity.
- The construction of bottom frame is as shown in the Figure-2.
- The construction of the top frame is, as shown in the figure -3.
- Thickness of the boards, used for sheathing for the top, sides and end panels, shall be 25 mm.
- The top of the Box consist of Beam supported on top traverse bar and sheathing, as shown in the figure- 3.
- The dimension of items 1, 2 f figure -3 shall be as table - 3.
- Diagonal braces shall be used in packing cases with height, exceeding 600 mm as shown in the figure- 4.
- The angle between the lower (or) upper horizontal supports and diagonal braces, shall be in the range of 20° to 60° and if possible, this angle preferably be kept at 45°.
- If the height of the box exceeds more than 1400 mm the diagonal braces, shall cross each other and when this dimension exceeds 1800mm additional horizontal supports shall be provided as shown in figure-5 and figure- 6.
- Size of upper and lower horizontal supports and vertical supports, shall be as per Table 4 refer figure 7, 8, 9 & 10 for the arrangement.
- The cross section of end traverses bar (item -1) and thickness of bottom boards (item-2), shall be used as per table - 5.
- All boxes measuring more than 600 mm height shall be constructed by assembling end, side and top shoo's on a bottom, forming a complete enclosed Box (refer figure-11).
- Angle iron cleats shall be used for strengthening the joints, as indicated in figure -12.
- Boxes will be strengthened by steel bands to withstand transit damages.

Packaging Instructions for Piping
Components

Doc. No
PC: PKG:01
Rev No: 00
Date : 28 /05/ 2014

No of Sheets : 24

9. Reference drawings

1. SLIDE
2. LONGITUDINAL UNDER SLIDE BOARD.
3. BOTTOM BOARD
4. CARRIER TRAVERSE BAR
5. INTERMEDIATE VERTICAL SUPPO
6. HORIZONTAL BRACING
7. DRAINAGE HOLES
8. BATTEN
9. SLING PLATE
10. NUT BOLT WASHER
11. END TRAVERSE BAR
12. WATER PROOF LINING OF BITUMANISED PAPER
13. VERTICAL SUPPORTS
14. END SHETING BOARD
15. SIDE SHEATING BOARD
16. TOP SHEATING BOARD
17. LONGITUDINAL SUPPORT
18. TOP HORIZONTAL BEAM
19. TOP SHEATING BOARD
20. TOP CORNER STRIPS (FOR STRENGTHENING)
21. OUT SIDE DOCUMENTS CONTAINER.

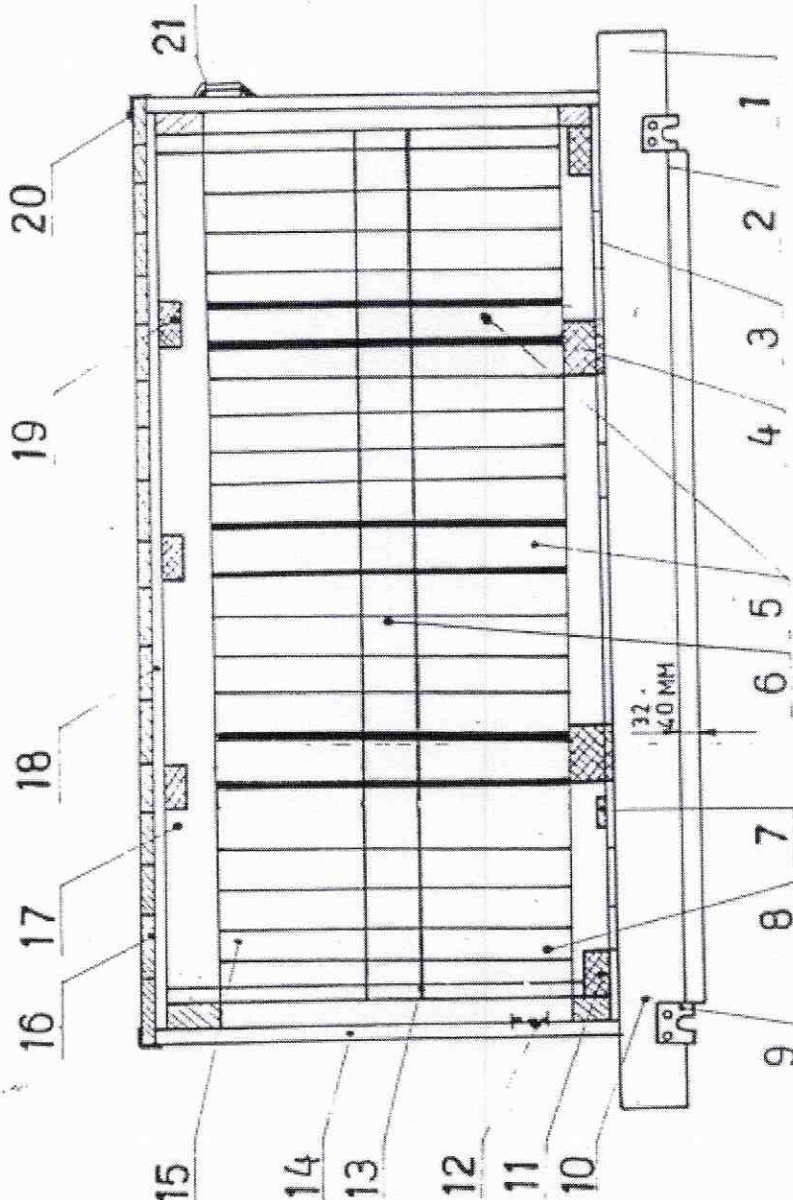

FIG. 1

NOMENCLATURE OF PARTS OF PACKING

Packaging Instructions for Piping
Components

Doc. No
PC: PKG:01
Rev No: 00
Date : 28 /05/ 2014

No of Sheets : 24

BOTTOM FRAME ARRANGEMENTS FOR TYPES
633, 654, 966, 1296, 1122, 1144, 1399, 1577

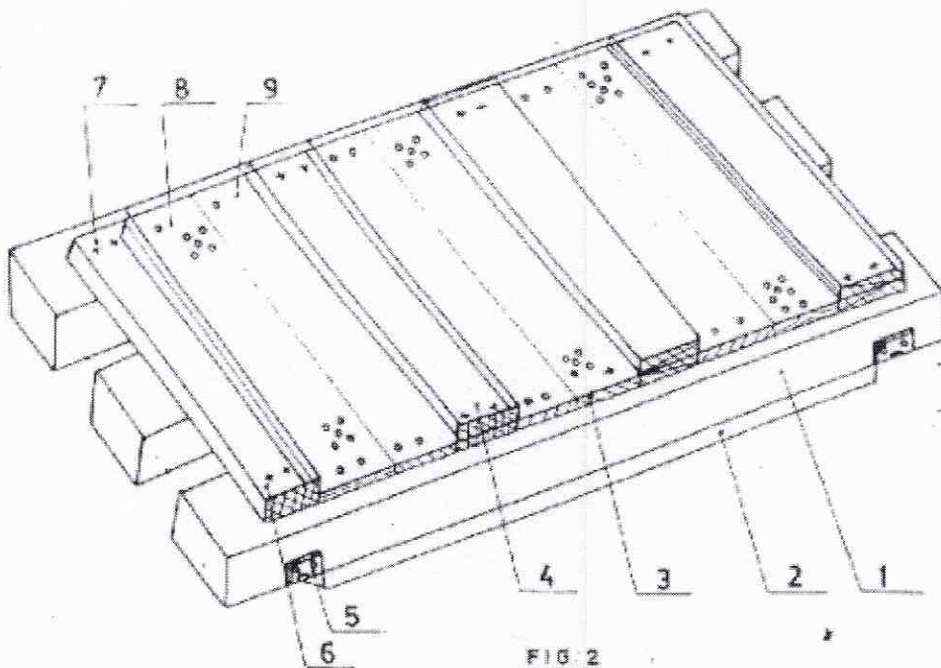

FIG 2

1. SLIDE
2. UNDER SLIDE BOARD
3. BOTTOM BOARD
4. CARRIER TRAVERSE BAR
5. SLING PLATE
6. TRAVERSE BAR
7. BOLT, NUT & WASHER
8. DRAINAGE HOLES
9. NAILS

**Packaging Instructions for Piping
Components**

Doc. No
PC: PKG:01
Rev No: 00
Date : 28 /05/ 2014

No of Sheets : 24

TOP FRAME ARRANGEMENT FOR TYPES
633, 654, 966, 1296, 1122, 1144, 1399 & 1577

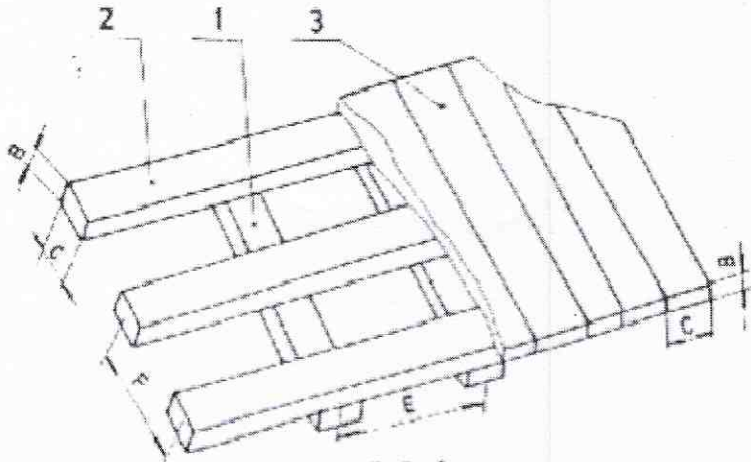

FIG - 3

- 1 - Traverse Bars
- 2 - Horizontal Scans
- 3 - Top Board

PROVISION OF DIAGONAL BRACING ARRANGEMENT

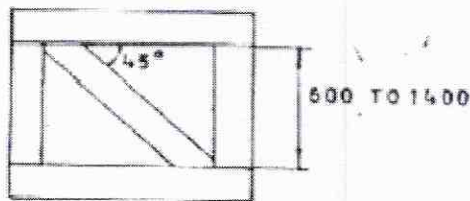

FIG:4



Packaging Instructions for Piping Components

Doc. No
PC: PKG:01
Rev No: 00
Date : 28 /05/ 2014

No of Sheets : 24

ARRANGEMENT OF DIAGONAL BRACING & HORIZONTAL SUPPORT

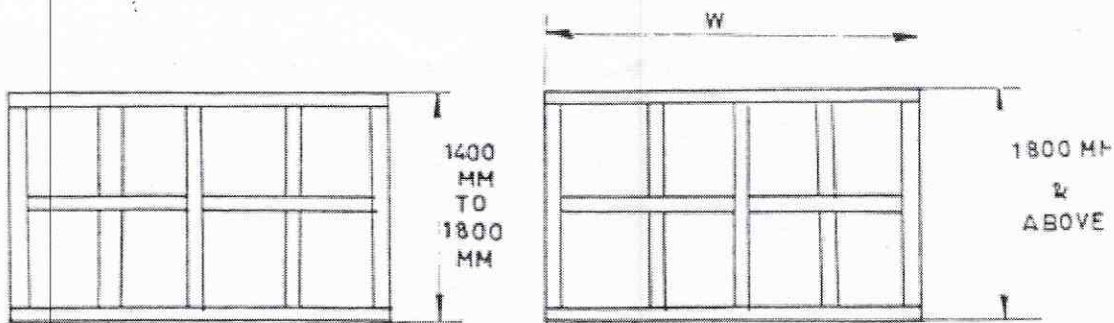

FIG. 5

FIG. 6

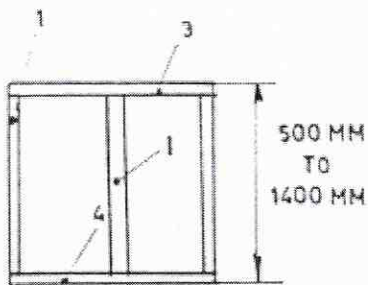

FIG : 7

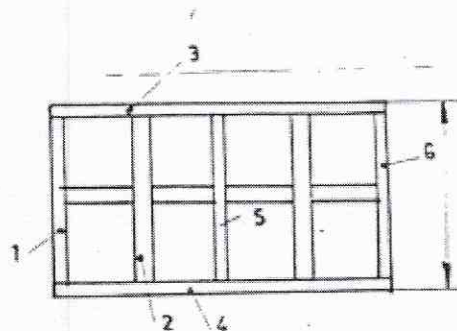

FIG: 8

1. VERTICAL SUPPORT

1, 2, 5, 6 - VERTICAL SUPPORT

3. UPPER HORIZONTAL SUPPORT

3 - UPPER HORIZONTAL SUPPORT

4. LOWER HORIZONTAL SUPPORT

4 - LOWER HORIZONTAL SUPPORT



**Packaging Instructions for Piping
Components**

Doc. No
PC: PKG:01
Rev No: 00
Date : 28 /05/ 2014

No of Sheets : 24

ARRANGEMENT OF DIAGONAL BRACING AND
HORIZONTAL SUPPORT

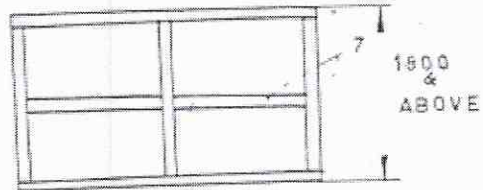
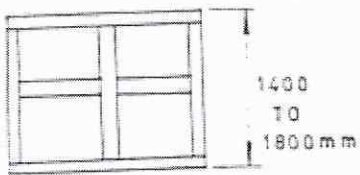

7 - MIDDLE HORIZONTAL SUPPORT

**Packaging Instructions for Piping
Components**

Doc. No
PC: PKG:01
Rev No: 00
Date : 28 /05/ 2014

No of Sheets : 24

ARRANGEMENT OF PACKING CASE

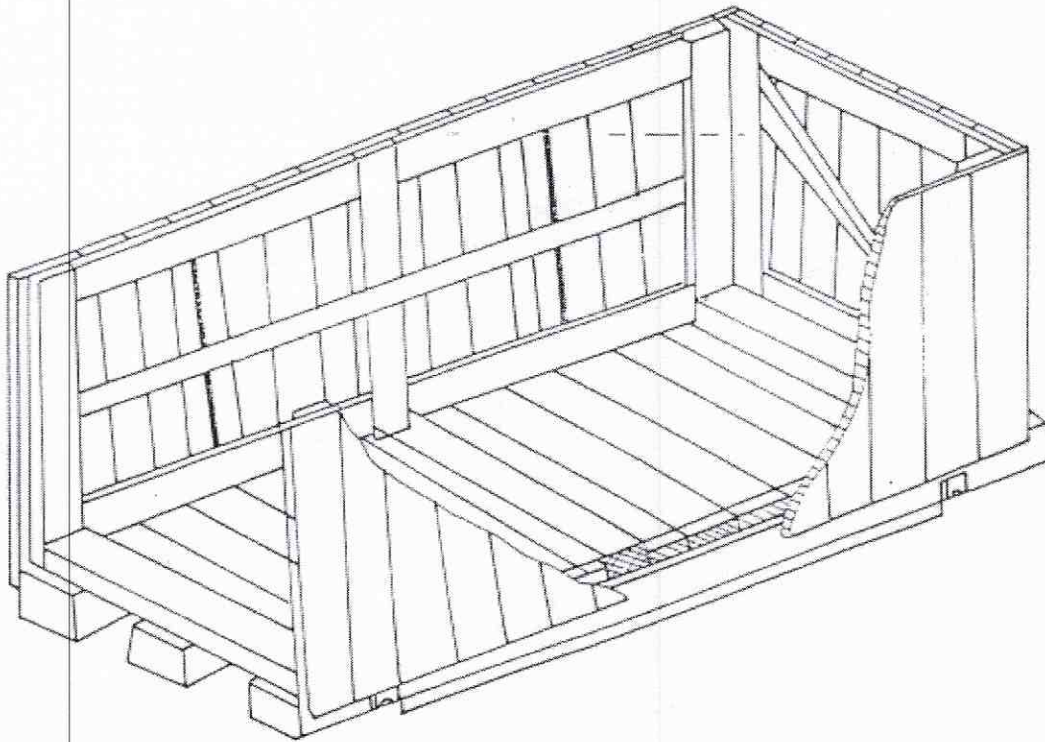

FIG : 11

**Packaging Instructions for Piping
Components**

Doc. No
PC: PKG:01
Rev No: 00
Date : 28 /05/ 2014

No of Sheets : 24

ARRANGEMENT OF ANGLE IRON CLEATS

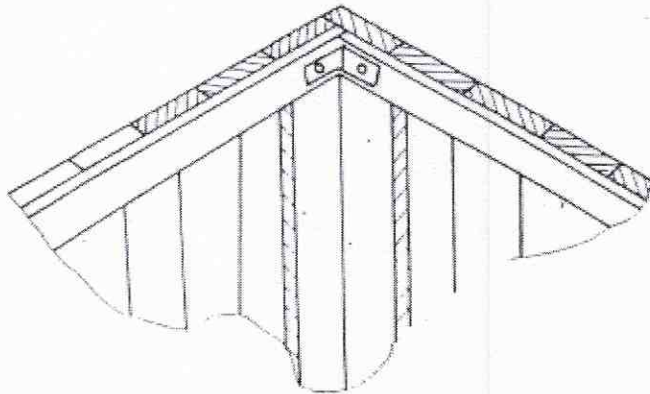

FIG:12

ARRANGEMENT OF C-CLAMPS AROUND CASES

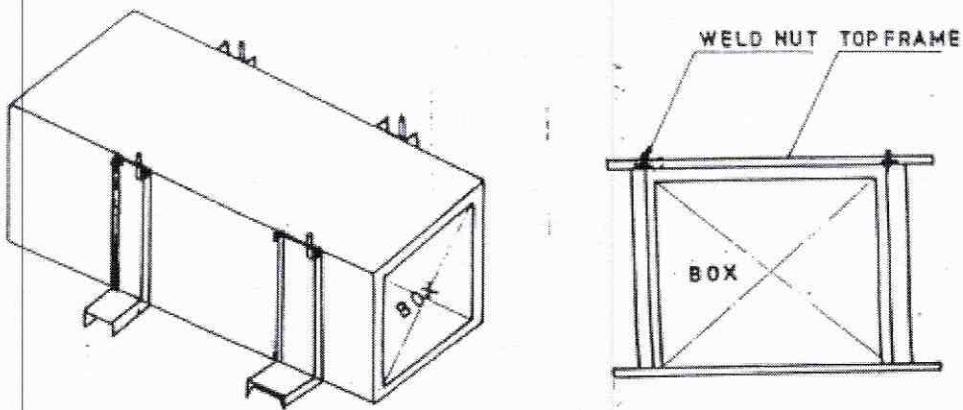

FIG:13

Packaging Instructions for Piping Components

Doc. No
PC: PKG:01
Rev No: 00
Date : 28 /05/ 2014

No of Sheets : 24

ARRANGEMENT OF SLING - PLATE ON CASES

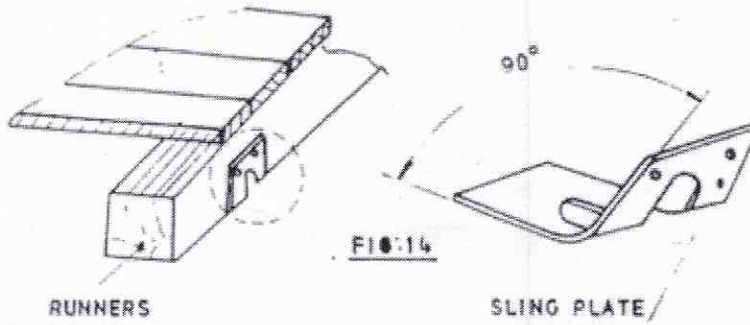

ARRANGEMENT OF SMALL CASES

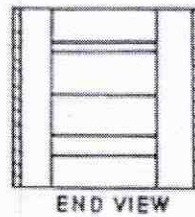
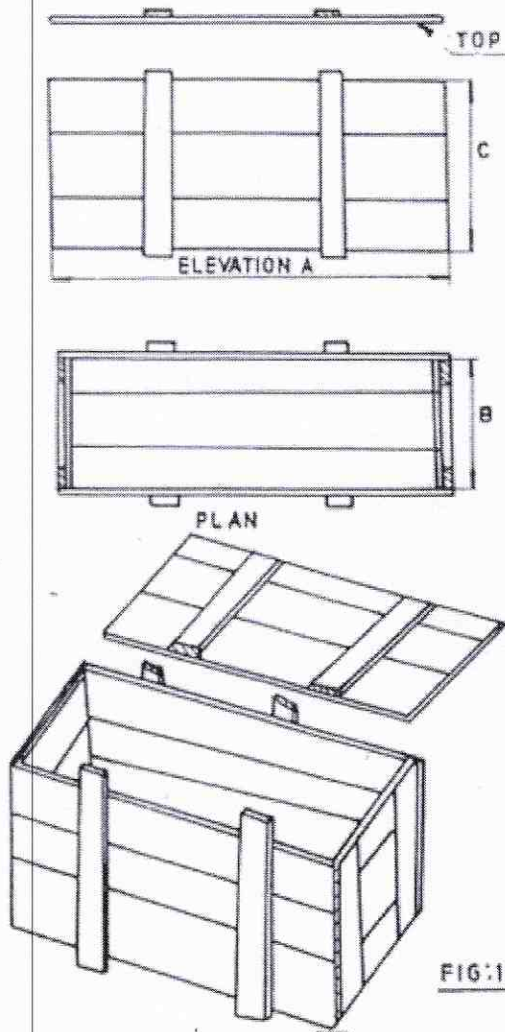

TYPE 654, 633

| DMS TYP | A | B | C |
|------------|-----|-----|-----|
| 654 | 600 | 500 | 400 |
| 633 | 600 | 300 | 300 |

IN MM ONLY

1. BOTTOM BOARD
 2. CROSS TRAVERS BOARD
- A. UNIFORMLY DISTRIBUTED
B. CONCENTRATED LOAD



Packaging Instructions for Piping Components

Doc. No
PC: PKG:01
Rev No: 00
Date : 28 /05/ 2014

No of Sheets : 24

The sizes of boxes given below are indicative. Actual sizes may vary according to size and positioning of component inside.

ANNEXURE – A

WOODEN BOXES

| TYPE | L X B X H (MM) | CARRYING CAPACITY IN KGS |
|------|-------------------------|-----------------------------|
| 633 | 600x300x300 | 200 |
| 654 | 600x500x400 | 500 |
| 966 | 900x600x600 | 1000 |
| 1296 | 1200x900x600 | 2000 |
| 1122 | 100x200x200 | 300 |
| 1144 | 110x400x400 | 300 |
| 1399 | 1300x900x900 | 2500 |
| 1577 | 1500 X 700 X 700 | 1500 |

TABLE - 1

| No. of slides | Length of slides | Weight in (kgs) | Types of loading |
|---------------|------------------|-----------------|---|
| 2 | 600 – 1800 mm | 0 – 1000 | Two slides for central loading near the ends or uniformly distributes load. |
| 3 | 1801 – 2500 mm | 1001 – 5000 | Three slides with load concentrates near the end or uniformly distributed load. |



Packaging Instructions for Piping Components

Doc. No
PC: PKG:01
Rev No: 00
Date : 28 /05/ 2014

No of Sheets : 24

TABLE - 2

| LOAD | Length of slides | | | | | | | |
|------|------------------|-----------|-----------|-----------|-----------|-----------|-----------|--|
| | 600 | 800 | 1000 | 1200 | 1300 | 1500 | 2000 | |
| | CROSS SECTION | | | | | | | |
| | B x C | | c | | | | | |
| | | | b | | | | | |
| 500 | 30 x 100 | 30 x 100 | 30 x 100 | 30 x 100 | 30 x 100 | 30 x 100 | 30 x 100 | |
| 800 | 30 x 100 | 30 x 100 | 100 x 100 | 100 x 100 | 100 x 100 | 100 x 100 | 100 x 100 | |
| 1000 | 30 x 100 | 100 x 100 | 100 x 100 | 100 x 100 | 100 x 100 | 100 x 100 | 100 x 100 | |
| 1500 | 100 x 100 | 100 x 100 | 100 x 100 | 100 x 100 | 100 x 100 | 100 x 100 | 100 x 100 | |
| 2000 | 100 x 100 | 100 x 100 | 100 x 100 | 100 x 100 | 100 x 100 | 100 x 100 | 100 x 100 | |
| 2500 | 100 x 100 | 100 x 100 | 100 x 100 | 100 x 100 | 100 x 100 | 120 x 150 | 120 x 150 | |
| 3000 | 100 x 100 | 120 x 150 | 120 x 150 | 120 x 150 | 120 x 150 | | | |

TABLE - 3

| Distance between top horizontal scans dim 'f' | Distance between the axis of the traverse bar dimension 'E' in fig -3 | | | | |
|---|---|----------|----------|----------|----------|
| | 500 | 600 | 700 | 800 | 900 |
| | Size b x c | | | | |
| 700 – 1000 mm | 30 x 100 | 30 x 100 | 30 x 100 | 30 x 100 | 30 x 100 |



Packaging Instructions for Piping Components

Doc. No
PC: PKG:01
Rev No: 00
Date : 28 /05/ 2014

No of Sheets : 24

TABLE-4

| End and side panels | Width of the panels | Distance Between Longitudinal Support DIM 'D' | | | | | | |
|---------------------|---------------------|---|----------|----------|----------|----------|----------|----------|
| | | 600 | 800 | 1000 | 1200 | 1400 | 1600 | 1800 |
| | | Cross section (b x c) Item 1 to 7 | | | | | | |
| Fig - 7 | 600 to 1200 | 30 x 100 | 30 x 100 | 30 x 100 | 30 x 130 | 30 x 130 | 30 x 130 | 30 x 130 |
| Fig - 8 | 1201 to 1600 | 30 x 130 | 30 x 130 | 30 x 130 | 30 x 130 | 30 x 130 | 30 x 130 | 30 x 130 |
| Fig - 9 | 1601 to 2000 | 30 x 130 | 30 x 130 | 30 x 130 | 30 x 130 | 30 x 130 | 30 x 130 | 30 x 130 |
| Fig - 10 | 2001 to 3000 | 30 x 130 | 30 x 130 | 30 x 130 | 30 x 130 | 30 x 130 | 30 x 130 | 40 x 150 |
| | 3001 to 4000 | 30 x 130 | 30 x 130 | 40 x 150 | 40 x 150 | 40 x 150 | 40 x 150 | 40 x 150 |



Packaging Instructions for Piping Components

Doc. No
PC: PKG:01
Rev No: 00
Date : 28 /05/ 2014

No of Sheets : 24

TABLE-5

BOTTOM TRAVERSE:

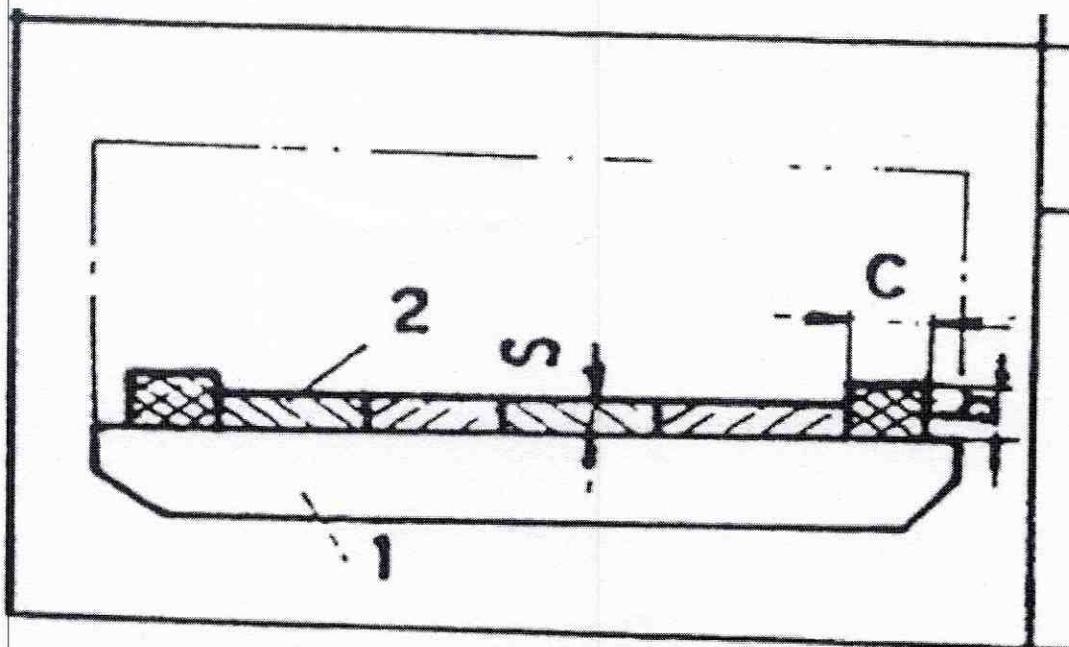

Cross section of end traverse bar item 1 fig. X and thickness of bottom board (item – 2)

| Load in kg | Width of the box | Cross section | S |
|------------|------------------|---------------|----|
| Up to 3000 | Above 1000 mm | 100 x 100 | 25 |



Packaging Instructions for Piping Components

Doc. No
PC: PKG:01
Rev No: 00
Date : 28 /05/ 2014

No of Sheets : 24

10. Cautionary symbols



FRAGILE, HANDLE WITH CARE

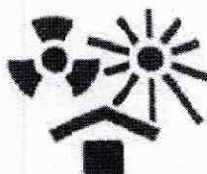

PROTECT FROM HEAT AND RADIOACTIVE SOURCES



USE NO HOOKS

NOTE: The design of heavy goods packages cannot always resist top lifting by grabhooks.



KEEP DRY

NOTE: Not all cases have waterproof internal liners; plywood used in the construction may not have a waterproof gluing.

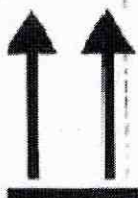

THIS WAY UP

NOTE: Certain designs of small cases make it difficult to distinguish top from bottom.

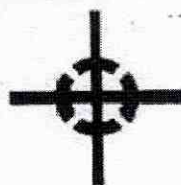

CENTRE OF GRAVITY

NOTE: This should be stencilled as a minimum on the two longest case sides (this information will normally be supplied by the manufacturer of the item(s) packed).

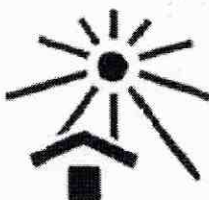

KEEP AWAY FROM HEAT

... kg max.



STACKING LIMITATION

NOTE: The maximum load in kilograms should be marked above the arrow.



International 'slings here' symbol



Packaging Instructions for Piping Components

Doc. No
PC: PKG:01
Rev No: 00
Date : 28 /05/ 2014

No of Sheets : 24

11. Packing Reference Table

TABLE-6

| No | Description | Packing Method -> | | | | | | Remarks |
|----|-----------------------------|-------------------|---------|-----------------|-----------------------------|----------------------|--------|--|
| | | Wooden Crates | Bundles | Saddle supports | HD Polythene Sheet Wrapping | Wooden boxes (Cases) | Spider | |
| 1 | Straight Pipes | ✓ | ✓ | | | | | Crates for random length |
| 2 | Pipes with attachments | ✓ | | | | | | |
| 3 | Pipes with Fittings | ✓ | | | | | | |
| 4 | Tanks | | | ✓ | | | | |
| 5 | Mitre bends | | | ✓ | | ✓ | | Saddle or cases to be used |
| 6 | Fasteners | | | | | ✓ | | |
| 7 | Hanger components | | | | | ✓ | | |
| 8 | Clamps | | | | | ✓ | | |
| 9 | Fittings >nb200/ Flanges | | | | | ✓ | | Fittings <200 shall be packed in boxes |
| 10 | Plates(Cut to size) | | | | | ✓ | | |
| 11 | SS Pipes | | ✓ | | ✓ | | | Wrap SS pipes before bundling |
| 12 | SS fittings / Flanges | ✓ | | | | ✓ | | Fittings <200 shall be packed in boxes |
| 15 | SS Fasteners | | | | | ✓ | | |
| 16 | CW piping(>900mm) | | | | | | ✓ | To maintain circularity of pipes |
| 17 | CW fittings(>900mm) | | | | | | ✓ | |
| 18 | CW fittings(<900mm) | | | | | | | |
| 19 | Structurals(<200mm) | | ✓ | | | | | |



Packaging Instructions for Piping Components

Doc. No
PC: PKG:01
Rev No: 00
Date : 28 /05/ 2014

No of Sheets : 24

12. CHECK LIST

| S No | VENDOR TO PROVIDE DETAILS | |
|------|--|--|
| 1 | On despatch of components/items , vendor has to provide the following information for each package of despatched items: 1. Contents of package (Packing list) 2. Corrosion Prevention: Rust-preventive coating /protective painting/Silica gel/ other corrosion inhibitors (please mention) 3. Lifting Instructions: Crane using slings/Fork lift/any other means (please mention) 4. Dimensions (LxBxH) mm: 5. Gross Weight (Kgs): 6. Net Weight (kgs): | |
| S No | VENDOR TO CONFIRM | |
| 1 | Where ever items are despatched as a bundle, they should be clamped together with bolted timber block clamps or bolted steel section clamps with timber block inserts. Adequate number of clamps should be provided along the length of the bundle with sufficient projection of the clamps beyond the width and height of the bundle. | |
| 2 | Only such materials which can withstand corrosion and environmental conditions are allowed to be packed in wooden crates or bundles. | |
| 3 | In case of wooden packing, planks of 20-25 mm thick and 100-150mm wide needs to be suitably placed at close intervals for giving rigidity to packing appropriately. | |
| 4 | Wood used for packing should be seasoned & shall be free of termites. | |
| 5 | Damages, if any, resulting due to improper/inadequate packing will be to vendors account. It will be the responsibility of the vendor to identify suitable and adequate packing for his supplies to protect it from damage and/or deterioration during storage, stacking, transport and handling. | |
| 6 | All packing should be suitable for loading/unloading by cranes/forklifts & suitable for transport by road. Suitable marking should be made on the packing indicating the lifting positions. | |