

DATA SHEET-C LT MOTOR

CLAUSE NO.	Bidder's Name	
	iii) No load Armature current (Amp)	
6.	Full load Field current (Amp)	
7.	No load Armature current (Amp)	
8.	Minimum permissible field current(Amp) to avoid	
	i) Maximum permissible voltage	
	ii) Rated voltage	
	iii) Minimum Permissible Voltage	
9.	Resistance (indicative Values) in ohm	
	i) Armature winding(Arm + IP + Series) at 25	
	ii) Field Winding at 25 deg. C	
10..	Inductance (indicative values)	
	i) Armature winding	
	ii) Field winding	
11	Value of trimmer resistance (ohm) to be connected in series with the shunt field to	
	i) 220 V DC	
	ii) 250 V DC	
	iii) 187 V DC	
12	Value of the external resistance (ohm)required to be connected in series with armature during starting only	
13	Technical data sheet for external resistance box	
14	GA drawing of motor	
15	Starting time calculation	
16	Starter resistance design calculation	
17	Electrical connection diagram of motor	
1X500 MW FGUTPP STAGE-IV	DATA SHEET-C LT MOTOR	



TITLE:
1 X 500 MW UNCHAHAR TPP STAGE-IV

**TECHNICAL SPECIFICATION FOR
HYDROGEN GENERATION PLANT**

SPECIFICATION NO. PE-TS-401-158-A001

VOLUME - II

SECTION -

REV.NO. 0 DATE : 01.09.2014

SHEET OF

SECTION – D3

DESIGN REQUIREMENTS CONTROL AND INSTRUMENTATION

NOTE: - Some of the design requirement specified in section D3 may not be applicable to the bidder design. These requirements shall be accepted as per manufacturer standard practice.

1.0 GENERAL TECHNICAL REQUIREMENTS (C&I)

- 1.0 The control of Hydrogen generation plant shall be through dual processor based PLC system. PLC unit shall be provided with two processors (main processing unit with memories) one for normal operation and one as cold standby. The PLC system shall be provided with necessary interface hardware and software for dual fiber optic connectivity including LIU (Light Interface Unit) at PLC end and interconnection with DDCMIS located at main plant Control Room for monitoring of signal information.

The communication protocol shall be OPC compliant. The dual fiber optic communication cable between bidder's control panels and BHEL's DDCMIS shall be in bidder's scope. Bidder shall submit PLC system configuration drawing along with functional write-up along with the offer. Provision shall be kept at PLC end to accept start/stop command from remote (DCS) through soft link.

- 1.1 Two nos. OWS with 19" color TFT monitor along with keyboard & mouse shall be provided by the bidder for operation & monitoring of the entire H2 generation plant. It shall be possible to use the same OWS as programming station. Bidder to provide one number A4 size color laser printer. Complete PLC based control system with OWS, 1x100% online intelligent UPS (30 Min back up) and 1x100% UPS battery (Ni-Cd) for H2 generation plant shall be in bidder's scope.
- 1.2 PLC control system shall be time synchronized with Master clock system of the main plant through RS-485/IRIG-B link to ensure uniform time indication throughout the Plant. The required provision shall be made by the bidder at PLC end to achieve the same. The time format shall be finalised by BHEL during detail engineering.
- 1.3 The software and hardware for the offered PLC system shall be of latest version and shall be upgradable. Bidder to ensure availability of the spares and service support for the offered PLC system for minimum 10 years after guarantee period.
- 1.4 All necessary instruments such as transmitters/ temperature elements/sensors/ switches/ gauges etc. shall be provided for safe, efficient, reliable operation and maintenance of the H2 generation plant. All instrument devices shall be provided with explosion proof enclosure as described in NEC (USA) Article 500, Class-I, Div. I or provided with suitable type Zener barriers of standard approved make meeting the requirements approved by the Chief Controller of Explosives, India and statutory authorities.
- 1.5 The quantity of instruments shall be as per tender P&ID and Design Memorandum /Philosophy as a minimum, for bidding purpose. However, bidder shall also include in his proposal all the instruments and devices, which are needed for completeness of the system/ equipment, supplied by bidder, even if the same is not specifically appearing in the P&ID and design philosophy. During detail engineering, if any such additional instruments are required for safer & reliable operation of plant, bidder shall supply the same without any price implication.
- 1.6 All the instrumentation, equipment and accessories under this specification shall be furnished as per technical specification and ranges, makes/numbers as approved by the owner during detail engineering.
- 1.7 The necessary root valves, impulse piping, drain cocks, gauge-zeroing cocks, valve manifolds and all the other accessories required for mounting / erection of the local instruments shall be furnished, even not specifically asked for, on as required basis.

The instruments fittings shall be of forged SS. Instrument piping shall be designed for maximum design pressure & temperature of the process. Pressure instrument connection shall be ½" or 12 mm pipe connection. The contacts of equipment mounted instruments, sensors, switches etc. for external connection including spare contacts shall be wired out to the LCP.

- 1.8 All electrical actuators shall be of integral starter type.
- 1.9 Following documents to be furnished by the bidder along with the bid:
 - PLC configuration diagram.
 - Duly stamped and signed copy of Quality Plans.
 - Requirement of electronic earthing, if any, for PLC based control system.
- 1.10 Drawings/Documents and data to be furnished after award of the contract:
 - Input/ Output signal list.
 - BOM of PLC.
 - Control panel/control desk/charger panel/battery GA drawings.
 - Power distribution scheme.
 - PLC control room layout drawing.
 - PLC and field instruments quality plan.
 - PLC data sheet.
 - Cable schedule and cable interconnection drawing.
 - Instrument Schedule.
 - Instrument Data sheets.
 - Any other document decided during detailed engineering.
- 1.11 Industrial grade furniture chairs (3 nos.), keypad (1 no.), Locker set (1 no.) etc. shall be in bidders scope. Revolving chairs with wheels and with provision for adjustments of height (hydraulically/gas lift) shall be provided for the operators in local control Room area. Chair pedestal shall be made of 5mm thick MS plate covered with poly-propylene cladding. Arm-rests in one piece shall be of poly-urethane and twin wheel castor of glass filled nylon. The exact details shall be finalized & approved by owner/purchaser during detailed engineering. All furniture shall be from reputed suppliers like Rittal / Godrej / Pyrotech or equivalent as approved by owner/ purchaser.
- 1.12 PLC programming console shall be provided with installed antivirus software with perpetual license.
- 1.13 Ensure, vendor shall provide all software on CDs along with required software licenses. Vendor shall maintain the Original CD's existing operating & application software. Software modification and up gradation, as & when required, shall also be covered under the vendor scope at no extra cost.
- 1.14 All instruments/drives shall be terminated on JB/Panel by Bidder. Instruments/Drives, JB/Panel, Connecting instrument cable & control cable are in Bidder's scope. The scope of cable shall be referred in Electrical scope split sheet in Electrical portion of the specification.
- 1.15 Bidder to provide Temperature transmitters along with its compensating cable, JB/rack & other Erection hardware.
- 1.16 Instrument installation and accessories required for the same shall be in Bidder's scope and shall be as per the attached instrument installation diagrams. However any

instrument/ analyser installation not covered in specification, the same shall be subject to customer and BHEL approval during detailed engineering.

- 1.17 Bidder to note that all the transmitters supplied by Bidder shall be rack mounted. The transmitter racks shall be in Bidder's scope. Also no instruments/analysers & JB's/Racks should be protruding on the walkway.

STANDARD PLC CONFIGURATION DIAGRAM FOR HYDROGEN GENERATION PLANT

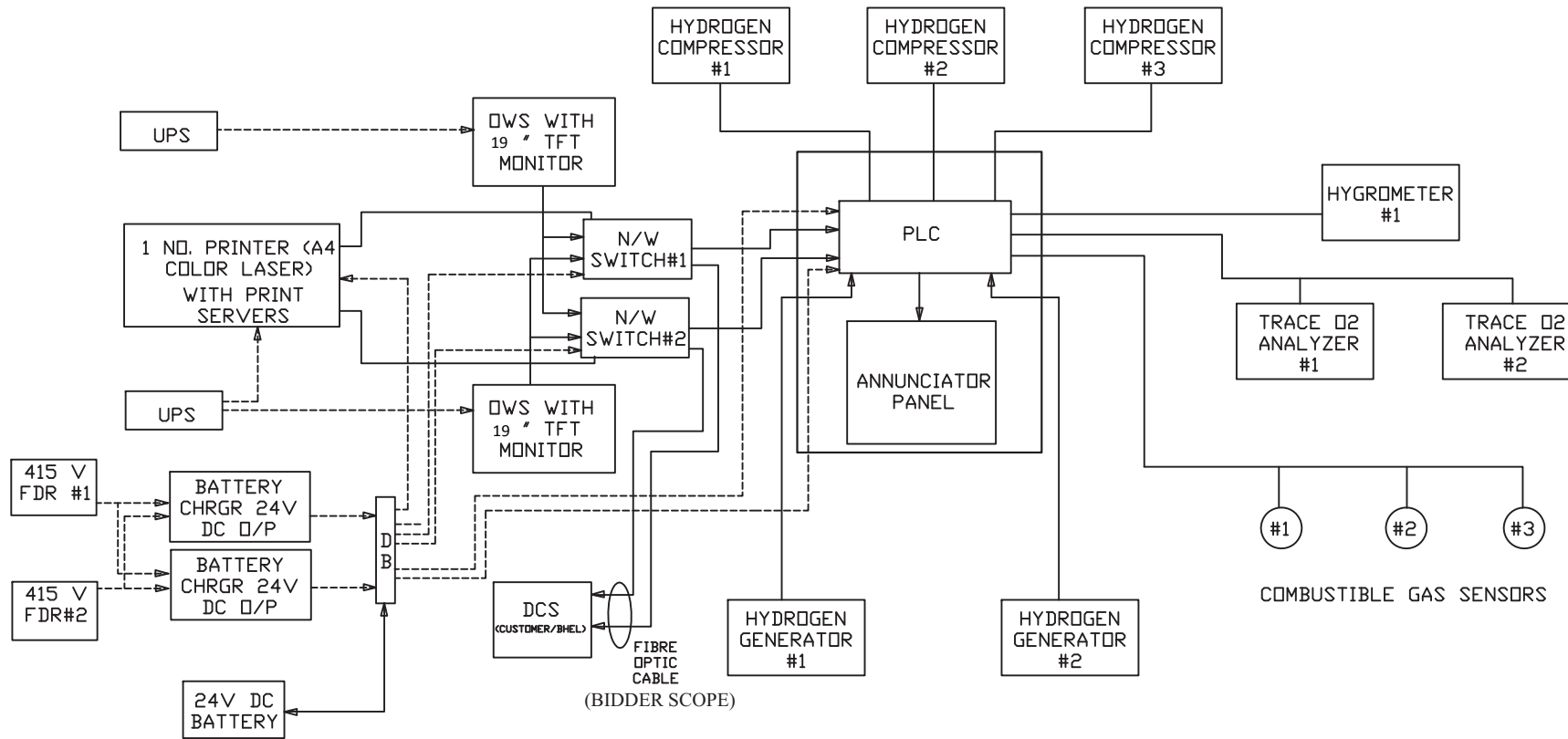

NOTES:

1. POWER TO PLC (IN THE ANNUNCIATOR PANEL) SHALL BE 24 V DC. BATTERY CHARGER AND BATTERY SHALL BE IN BIDDER'S SCOPE..
2. UPS FOR PC AND ITS MONITOR AND PRINTER SHALL BE SMART TYPE LINE INTERACTIVE TYPE WITH SOFTWARE AND HARDWARE ALONGWITH FEATURES OF SURGE SUPPRESSION & AVR FACILITY.
3. SELECTOR SWITCH SHALL BE PROVIDED IN PLC TO SELECT COLD STANDBY PROCESS INTO SERVICE.
4. FURNITURES FOR OWS, PRINTER SHALL BE IN BIDDER'S SCOPE.

CLAUSE NO.	TECHNICAL REQUIREMENTS		
PLANT AUXILIARY SYSTEM			
1.00.00	CONTROL AND INSTRUMENTATION FOR HYDROGEN GENERATION PLANT		
1.01.00	Contractor shall provide complete Control and Instrumentation system with all accessories, auxiliaries and associated equipments and cables for the safe, efficient and reliable operation of the plant auxiliary systems as indicated under scope part at IIC, Part-A, Section VI.		
1.02.00	The quantity of instruments for each plant auxiliary system shall be as per tender P&ID wherever provided of the respective system as a minimum, for bidding purpose. However, Bidder shall also include in his proposal all instruments and devices, which are needed for the completeness of the plant auxiliary system/equipment, supplied by the Contractor, even if the same is not specifically appearing in the P&ID.		
1.03.00	All electrical devices like switches/ transmitters/ controller/ analyzer/ solenoid valves which are located in the hydrogen generation plant shall be made intrinsically safe by providing suitable type of transformer isolated barrier/ Zenner barrier of standard make. Otherwise such instruments shall be provided with explosion proof enclosure suitable for hazardous areas described in National Electric Code (USA), Article 500, Class-I, Division-I or EN60079-14 or shall comply with the essential requirements of ATEX directives. All fittings, cable glands etc. shall be strictly as per NEC recommendation article, 500 to 503.		
1.04.00	Contractor shall provide PLC control systems for safe, efficient and reliable operation of each of the plant auxiliary systems. The type of control system shall be as indicated under scope part at IIC, Part-A, Section VI.		
1.05.00	Control, interlock/ protection, indication of incomers and bus-coupler (even if they are not in the scope of the contractor) are also to be performed from Contractor's Control System for each of the plant auxiliary system as applicable.		
1.06.00	It shall be possible to remove/replace online various modules (like any I/O module, interface module, etc.) from its slot for maintenance purpose without switching off power supply to the corresponding rack. System design shall ensure that while doing so, undefined signaling and releases do not occur and controller operation in any way is not affected (including controller trip to manual, etc) except that information related to removed module is not available to controller. Further, it shall also be possible to remove/replace of controller module without switching off the power to the corresponding rack and this will not result in system disturbance or loss of any controller functions for the other controller. The on-line removal/insertion of controller, I/O modules shall in no way jeopardize safety of plant and personnel.		
1.07.00	The control system shall provide safe operation under all plant disturbances and on component failure so that under no condition the safety of plant, personnel or equipment is jeopardized. Control system shall be designed to prevent abnormal swings due to loss of Control System power supply, failure of any Control System component, open circuit/short circuit etc.		
SINGRAULI STPP STAGE-III (1X500 MW) EPC PACKAGE	TECHNICAL SPECIFICATION SECTION-VI PART-B	SUB-SECTION-C-12(B) PLANT AUXILIARY SYSTEM	PAGE 1 OF 13



08642

CLAUSE NO.	TECHNICAL REQUIREMENTS		
1.08.00	<p>The Control system shall include on-line self-surveillance, monitoring and diagnostic facility giving the details of the fault on the Human Machine Interface System (HMIS). The faults to be reported shall include fault in main & standby power supplies, sensor fault, Input/ Output card failure, Memory Status, Controller fault, failure of Communication/ Network links to PLCs, LAN etc. These faults shall be reported as colour change on system status display and as messages on HMIS as well as through local indication on the faulty module and on respective rack/ cubicle. The diagnostic system shall ensure that the faults are detected before any significant change in any controller output has taken place.</p>		
1.09.00	<p>The Control system shall operate in non-air conditioned area and shall meet the minimum requirements as specified below.</p>		
2.00.00	<p>PROGRAMMABLE LOGIC BASED CONTROL SYSTEM</p>		
2.01.00	<p>PLC PROCESSOR</p> <p>The processor unit shall be capable of executing the following functions:-</p> <ul style="list-style-type: none"> a Receiving binary and analog signals from the field and providing command output to MCC/SWGR/Drive etc. through Input / Output modules and operator initiated commands from HMIS / control panel. b Implementing all logic functions for control, protection and annunciation of the equipment and systems. c Implementing modulating control function for certain application as specified elsewhere in the specification. d Providing supervisory information for alarm, various types of displays, status information, trending, historical storage of data etc. e Performing self-monitoring and diagnostic functions. 		
2.02.00	<p>The memory shall be field expandable. The memory capacity shall be sufficient for the complete system operation and have a capability for at least 20% expansion in future. Programmed operating sequences and criteria shall be stored in non volatile semi conductor memories like EPROM. All dynamic memories shall be provided with buffer battery back up which shall be for at least 360 hours. The batteries shall be lithium or Ni-Cd type.</p>		
2.03.00	<p>Priority of different commands shall be as follows:</p>		
2.03.01	<p>Manual intervention shall be possible at any stage of operation. Protection commands shall have priority over manual commands and manual commands shall prevail over auto commands.</p>		
2.03.02	<p>A forcing facility shall be provided for changing the states of inputs and outputs, timers and flags to facilitate fault finding and other testing requirements. It shall be possible to display the signal flow during operation of the program.</p>		
SINGRAULI STPP STAGE-III (1X500 MW) EPC PACKAGE	TECHNICAL SPECIFICATION SECTION-VI PART-B	SUB-SECTION-C-12(B) PLANT AUXILIARY SYSTEM	PAGE 2 OF 13

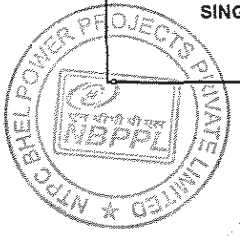

Handwritten signature

CLAUSE NO.	TECHNICAL REQUIREMENTS	एनटीपीसी NTPC	
2.04.00	HUMAN MACHINE INTERFACE SYSTEM (HMIS)		
2.04.01	Operator work station (OWS) shall perform control, monitoring and operation of all auxiliaries/ drives interacting with PLC based control system. It shall be possible to use the same as programming station of the PLC and the Human Machine Interface System. It shall basically perform the following functions. In case the PC based OWS can not be used as programming station of the PLC and the Human Machine Interface System, then separate PC based programming station shall be provided.		
2.04.02	Operator shall be able to access all control/information related data under all operating conditions including a single processor/computer failure in the HMIS.		
2.04.03	All frequently called important functions including major displays shall be assigned to dedicated function keys on a soft keyboard for the convenience of the operator for quick access to displays & other operator functions.		
2.04.04	The operator functions for each OWS shall as a minimum include Control System operation (A/M selection, raise/lower, set point/bias change, on/off, open/close operation, mode/device selection, bypassing criteria, sequence auto, start/stop selection, drive auto selection, local-remote/other multi-position selection etc.); alarm acknowledge; call all kind of displays, logs, summaries, calculation results, etc.; printing of logs & reports; retrieval of historical data; and any other functions required for smooth operation, control & management of information as finalized during detailed engineering.		
2.04.05	The display selection process shall be optimized so that the desired display can be selected with the minimum no. of operations. Navigation from one display to any other should be possible efficiently through paging soft keys as well as through targets defined on the displays. There should be no limitation on number of such targets.		
2.04.06	The system shall have built-in safety features that will allow/disallow certain functions and entry fields within a function to be under password control to protect against inadvertent and unauthorised use of these functions. Assignment of allowable functions and entry fields shall be on the basis of user profile. The system security shall contain various user levels with specific rights as finalised by the Employer during detailed engineering. However, no. of user levels, no. of users in a level and rights for each level shall be changeable by the programmer (Administrator).		
2.05.00	When any drive or sequence is being controlled from one OWS, the system shall inhibit control access of the same drive or sequence from other OWS or Local Control Panel.		
2.06.00	<p>PROGRAMMING FUNCTIONALITIES</p> <p>Programming of the PLC Processor / controller as well as programming of HMIS shall be user friendly with graphical user interface and shall not require knowledge of any specialized language. For example, the programming of PLC shall use either of the following:-</p> <ul style="list-style-type: none"> - Flow-chart or block logic representing the instructions graphically. - Ladder diagrams. 		
SINGRAULI STPP STAGE-III (1X500 MW) EPC PACKAGE	TECHNICAL SPECIFICATION SECTION-VI PART-B	SUB-SECTION-C-12(B) PLANT AUXILIARY SYSTEM	PAGE 3 OF 13

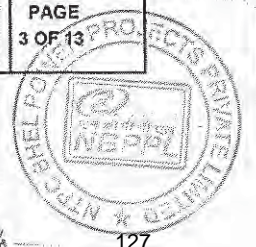

08644

CLAUSE NO.	TECHNICAL REQUIREMENTS 		
	<p>The programming of HMIS (like development and modification of data base, mimics, logs / reports, HSR functionalities etc.) shall also be possible through user-friendly menus etc</p> <p>All programming functionalities shall be password protected to avoid unauthorized modification.</p>		
2.07.00	<p>SOFTWARE REQUIREMENT</p>		
2.07.01	<p>All necessary software required for implementation of control logic, operator station displays / logs, storage & retrieval and other functional requirement shall be provided. The programs shall include high level languages as far as possible. The contractor shall provide sufficient documentation and program listing so that it is possible for the Employer to carry out modification at a later date.</p>		
2.07.02	<p>The Contractor shall provide all software required by the system for meeting the intent and functional/parametric requirements of the specification.</p>		
2.07.03	<p>Industry standard operating system like UNIX/WINDOWS (latest version) etc. to ensure openness and connectivity with other system in industry standard protocols (TCP-IP/ OPC etc.) shall be provided. The system shall have user friendly programming language & graphic user interface.</p>		
2.07.04	<p>All system related software including Real Time Operating System, File management software, screen editor, database management software. On line diagnostics/debug software, peripheral drivers software and latest versions of standard PC-based software and latest WINDOWS based packages etc. and any other standard language offered shall be furnished as a minimum.</p>		
2.07.05	<p>All application software for PLC system functioning like input scanning, acquisition, conditioning processing, control and communication and software for operator interface of monitors, displays, trends, curves, bar charts etc. Historical storage and retrieval utility, and alarm functions shall be provided.</p>		
2.07.06	<p>The Contractor shall provide software locks and passwords to Employer's engineers at site for all operating & application software so that Employer's engineers can take backup of these software and are able to do modifications at site.</p>		
2.08.00	<p>PARAMETRIC REQUIREMENTS</p> <p>The control system shall be designed such that under worst case loading conditions the response time shall not be worst than the following:-</p> <p>On/Off Command - The response time for screen update after the execution of the control command from the time the command is issued (for example command to start a motor to the time the screen is updated) shall be two seconds (excluding the drive actuation time).</p> <p>Adjustment Command - 0.5 to 1 second.</p>		
<p>SINGRAULI STPP STAGE-III (1X500 MW) EPC PACKAGE</p>	<p>TECHNICAL SPECIFICATION SECTION-VI PART-B</p>	<p>SUB-SECTION-C-12(B) PLANT AUXILIARY SYSTEM</p>	<p>PAGE 4 OF 13</p>

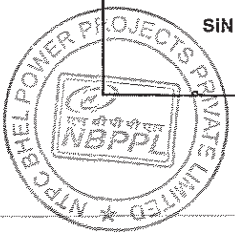

odh

CLAUSE NO.	TECHNICAL REQUIREMENTS		
	<div data-bbox="1268 264 1401 331" style="float: right; border: 1px solid black; padding: 2px;"> भारतीय NTPC </div> <p>On screen Updating - 1 second.</p> <p>All Control related displays - 1 second.</p> <p>Bar Chart displays - 2 to 3 seconds.</p> <p>Plant Mimic displays - 2 to 3 seconds.</p> <p>Group review displays - 2 to 3 seconds.</p> <p>X-T Plot Displays - 1 to 2 seconds.</p> <p>Plant Summary Displays - 1 to 2 seconds.</p> <p>Even under worst case loading condition of HMIS and system Bus, each HMIS processor shall have 50 % spare time when measured over any one minute period and the system bus shall have at least 50 % spare duty cycle.</p>		
3.00.00	INPUT/OUTPUT MODULES		
3.01.00	The PLC system should be designed according to the location of the input/output cabinets as specified.		
3.02.00	Input Output modules, as required in the Control System for all type of field input signals (4-20 mA, RTD, Thermocouple, non change over/change over type of contact inputs etc.) and outputs from the control system (non change over/change over type of contact, 24/48 VDC output signals for energizing interface relays, 4-20 mA output etc.) are to be provided by the Contractor. Contractor to refer drawing nos. 0000-999-POI-A-065 for interface/termination requirements of Field Instruments/Drives.		
3.03.00	Electrical isolation of 1.5KV with optical couplers between the plant input/output and controller shall be provided on the I/O cards. The isolation shall ensure that any inadvertent voltage or voltage spikes (as may be encountered in a plant of this nature) shall not damage or mal-operate the internal processing equipment.		
3.04.00	The Input/output system shall facilitate modular expansion in fixed stages. The individual input/output cards shall incorporate indications on the module front panels for displaying individual signal status.		
3.05.00	Individually fused output circuits with the blower fuse indicator shall be provided. All input/output points shall be provided with status indicator. Input circuits shall be provided with fuses preferably for each input, alternatively suitable combination of inputs shall be done and provided with fuses such that for any fault, fuse failure shall affect the particular drive system only without affecting other systems.		
3.06.00	All input/output cards shall have quick disconnect terminations allowing for card replacement without disconnection of external wiring and without switching of power supply.		
3.07.00	The Contractor shall provide the following monitoring features:		
<p style="text-align: center;">SINGRAULI STPP STAGE-III (1X500 MW) EPC PACKAGE</p>	<p style="text-align: center;">TECHNICAL SPECIFICATION SECTION-VI PART-B</p>	<p style="text-align: center;">SUB-SECTION-C-12(B) PLANT AUXILIARY SYSTEM</p>	<p style="text-align: center;">PAGE 5 OF 13</p>

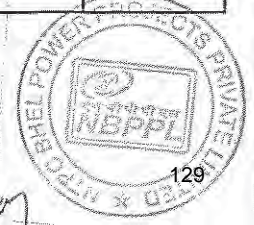

-08646

CLAUSE NO.	TECHNICAL REQUIREMENTS		
	<p>a Power supply monitoring.</p> <p>b Contact bounce filtering.</p> <p>c Optical isolation between input and output signals with the internal circuits</p> <p>d In case of power supply failure or hardware fault, the critical outputs shall be automatically switched to the fail-safe mode. The fail-safe mode shall be intimated to the successful Contractor during detailed engineering.</p>		
3.08.00	Binary Output modules shall be rated to switch ON/OFF coupling relays of approx. 3 VA at 24 VDC. Analog output modules shall be able to drive an load impedance of 500 Ohms minimum.		
3.09.00	Output module shall be capable of switching ON/OFF inductive loads like solenoid valves, auxiliary relays etc. without any extra hardware.		
3.10.00	Only one changeover contact shall be provided in MCC for control and interlock requirement. Further multiplication, if required, shall be done by the contractor in PLC system.		
3.11.00	All input field interrogation voltage shall be 24V DC or 48 V DC.		
3.12.00	In case of loss of I/O communication link with the main processing unit, the I/O shall be able to go to predetermined fail safe mode (to be decided during detailed engineering) with proper annunciation.		
3.13.00	Wiring Scheme for inputs to control system shall be as follows:		
3.13.01	Each of the triple redundant binary & analog inputs shall be wired to separate input modules. Similarly each of the dual redundant binary & analog inputs shall be wired to separate input modules. These redundant modules shall be placed in different racks, which will have separately fused power supply distribution. Implementation of multiple measurement schemes of these inputs will be performed in the redundant hardware. Loss of one input module shall not affect the signal to other modules. Other channels of these modules can be used by other inputs of the same functional group.		
3.13.02	The single (i.e. non-redundant) binary & analog signal required for control purposes shall be wired as follows:		
3.13.03	All single analog & binary inputs including the limit switches of valves/dampers MCC/SWGR check-backs of all drives & information related signals shall be wired to single (i.e. non-redundant) input modules.		
3.13.04	The on-off status of HT drives etc, however, be wired to two input modules in parallel.		
3.14.00	Inputs and Outputs related to each of the redundant drives / equipments (eg. each of the 3x50 % drives, each of the storage vessel/sump/tank storing same fluid, each of the streams and its related drives etc.) shall be wired to separate input and output modules.		
SINGRAULI STPP STAGE-III (1X500 MW) EPC PACKAGE	TECHNICAL SPECIFICATION SECTION-VI PART-B	SUB-SECTION-C-12(B) PLANT AUXILIARY SYSTEM	PAGE 6 OF 13

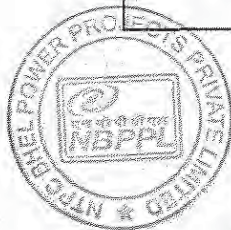

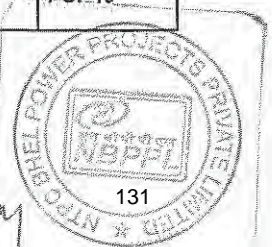

CLAUSE NO.	<p style="text-align: center;">TECHNICAL REQUIREMENTS</p> <div style="text-align: right; border: 1px solid black; padding: 2px;"> एन.डी.पी.सी. NTPC </div>																		
3.15.00	<p>The signal conditioning functions like multiple measurement schemes, square root extraction for flow signals, pressure and temperature compensation, limit value computation can be performed either in the controllers or in signal conditioning and processing hardware outside controllers.</p> <p>The maximum number of inputs/outputs to be connected to each type of module shall be as follows:</p> <table style="width: 100%; border-collapse: collapse;"> <tr> <td style="width: 5%;">1.</td> <td style="width: 85%;">Analog input module</td> <td style="width: 10%; text-align: right;">16</td> </tr> <tr> <td>2.</td> <td>Analog output module</td> <td style="text-align: right;">16</td> </tr> <tr> <td>3.</td> <td>Binary input module</td> <td style="text-align: right;">32</td> </tr> <tr> <td>4.</td> <td>Binary output module</td> <td style="text-align: right;">32</td> </tr> <tr> <td>5.</td> <td>Analog input & output (combined)</td> <td style="text-align: right;">16</td> </tr> <tr> <td>6.</td> <td>Binary input and output (combined)</td> <td style="text-align: right;">32</td> </tr> </table>	1.	Analog input module	16	2.	Analog output module	16	3.	Binary input module	32	4.	Binary output module	32	5.	Analog input & output (combined)	16	6.	Binary input and output (combined)	32
1.	Analog input module	16																	
2.	Analog output module	16																	
3.	Binary input module	32																	
4.	Binary output module	32																	
5.	Analog input & output (combined)	16																	
6.	Binary input and output (combined)	32																	
3.16.00	<p>Any single sensor/transducer/transmitter failure alarm shall be provided on programmer station screens for all sensors/transducers/transmitters. Similarly sensor break alarm for thermocouples etc. shall also be displayed on the screens.</p>																		
3.17.00	<p>Contractor shall provide remote Input/Output modules Housed in free-standing cabinets/racks (with suitable redundant data link to the central PLC system) as specified. These Input/Output modules shall meet the technical requirements as mentioned in the above clauses. Further these Input/Output modules shall be designed to continuously work under the environment expected to be encountered in assigned areas without any air-conditioning support. Wherever the cable route distance of these I/O cabinets/racks exceeds a distance of 300 meters from the Central PLC, fiber optic data link has to be provided.</p>																		
4.00.00	<p>SYSTEM SPARE CAPACITY</p>																		
4.01.00	<p>Over and above the equipment and accessories required to meet the fully implemented system as per specification requirements, Control System shall have spare capacity and necessary hardware/ equipment/ accessories to meet following requirement for future expansion at site:</p>																		
4.02.00	<p>10% spare channels in input/output modules fully wired up to cabinets TB.</p>																		
4.03.00	<p>Wired-in "usable" space for 20% modules in each of the system cabinets for mounting electronic modules wired up to corresponding spare terminals in system cabinets. Empty slots between individual modules/group of modules, kept for ease in maintenance or for heat dissipation requirement as per standard practice of Contractor shall not be considered as wired-in "usable" space for I/O modules. Terminal assemblies (if any in the offered system), corresponding to the I/O modules shall be provided for above mentioned 20 % blank space.</p>																		
SINGRAULI STPP STAGE-III (1X500 MW) EPC PACKAGE	TECHNICAL SPECIFICATION SECTION-VI PART-B	SUB-SECTION-C-12(B) PLANT AUXILIARY SYSTEM	PAGE 7 OF 13																

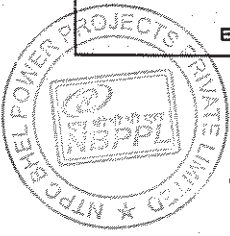

08648

CLAUSE NO.	<p style="text-align: center;">TECHNICAL REQUIREMENTS</p> 		
4.04.00	<p>Each processor / controller shall have 30% spare functional capacity to implement additional function blocks, over and above implemented logic/ loops. Further, each processor / controller shall have spare capacity to handle minimum 30% additional inputs/ outputs of each type including above specified spare requirements, over and above implemented capacity. Each of the corresponding communication controllers shall also have same spare capacity as that of processor/controller.</p>		
4.05.00	<p>The Data communication system shall have the capacity to handle the additions mentioned above.</p>		
4.06.00	<p>Twenty (20) percent spare relays of each type and rating mounted and wired in cabinets TB. All contacts of relays shall be terminated in terminal blocks of cabinets.</p>		
4.07.00	<p>The spare capacity as specified above shall be uniformly distributed throughout all cubicles. The system design shall ensure that above mentioned additions shall not require any additional controller/processor/ peripheral drivers in the system delivered at site. Further, these additions shall not deteriorate the system response-time / duty cycle, etc. from those stipulated under this specification.</p>		
5.00.00	DATA COMMUNICATION SYSTEM (DCS)		
5.01.00	<p>The Communication System shall include a Main System Bus and Other applicable bus systems like cubicle bus, local bus, I/O bus etc.</p> <p>The DCS shall have the following minimum features :</p> <ul style="list-style-type: none"> a Communication controllers shall be provided to handle the communication between I/O Modules (including remote I/O) and PLCs and between PLCs and operator work station/HMI device. b The design shall be such as to minimise interruption of signals. It shall ensure that a single failure anywhere in the media shall cause no more than a single message to be disrupted and that message shall automatically be retransmitted. Any failure or physical removal of any station/module connected to the system bus shall not result in loss of any communication function to and from any other station/module. c Built-in diagnostics shall be provided for easy fault detection. Communication error detection and correction facility (ECC) shall be provided at all levels of communication. Failure of one bus and changeover to the standby system bus shall be automatic and completely bump less and the same shall be suitably alarmed/logged. e The design and installation of the system bus shall take care of the environmental conditions as applicable. f Data transmitting speed shall be sufficient to meet the responses of the system in terms of displays, control etc. plus 25% spare capacity shall be available for future expansion. g Passive coaxial cables or fibre optic cables shall be employed. 		
<p style="text-align: center;">SINGRAULI STPP STAGE-III (1X500 MW) EPC PACKAGE</p>	<p style="text-align: center;">TECHNICAL SPECIFICATION SECTION-VI PART-B</p>	<p style="text-align: center;">SUB-SECTION-C-12(B) PLANT AUXILIARY SYSTEM</p>	<p style="text-align: center;">PAGE 8 OF 13</p>



CLAUSE NO.	TECHNICAL REQUIREMENTS									
5.02.00	<p>The Contractor shall furnish details regarding the communication system like communication protocol, bus utilisation calculations etc.</p> <p>The PLC system shall be provided with necessary hardware and software for dual fibre optic connectivity & interconnection with station wide LAN (In Employer's Scope) for two - way transfer of signals for the purpose of information sharing. The plant information shall be made available through an Ethernet link following TCP/IP standard. The system shall be OPC compliant. The exact data structure shall be as decided during detailed engg. All required plant data shall be transferred to/from through this ensuring complete security. The exact number of points to be transferred through the above communication link and the format of the data shall be finalised during detailed engineering. The Contractor shall provide all assistance to the BOP C&I System (In Employer's Scope) Supplier including co-ordination and flow of required information etc. for display of all input points under alarm, connected to PLC or generated by PLC, on various operating stations on BOP C&I System (In Employer's Scope) and various client PCs on station LAN.</p>									
6.00.00	SYSTEM REACTION TIME									
6.01.00	<p>The reaction time of the programmable control system from input signals at the input cards to output of the associated signals or commands of the output card inclusive of programmed logic processing, comprising a mixture of logic gates, arithmetic operations and other internal operations shall be less than 100 milli seconds under the most arduous control system operating conditions.</p>									
7.00.00	OPERATOR INTERFACE DISPLAYS/LOGS/REPORTS									
7.01.00	<p>Suitable Operator Interface Displays/Logs/Reports for control operation & monitoring shall be provided. The details shall be finalized during detailed Engg. stage.</p>									
7.02.00	<p>Minimum quantities shall be as follows:-</p> <ol style="list-style-type: none"> 1 Various displays on the OWS shall as a minimum include P&ID displays or mimic, bar chart displays, X-Y & X-T plot (trend) displays, operator guidance message displays, group displays, plant start-up/shutdown message displays, system status displays etc. Number of displays and the exact functionality shall be on as required basis and as finalised during detailed engineering subject to the minimum quantities as given in subsequent clauses. For X-T & X-Y plots, the facility of providing a background grid on operator request shall be variable with adequate no. of divisions in both co-ordinates. 2 The minimum quantity of major types of displays per unit shall be as follows: <table border="1" data-bbox="497 1664 1375 1877"> <tbody> <tr> <td data-bbox="497 1664 603 1783">a)</td> <td data-bbox="603 1664 1161 1783">Control displays (group/sub-group/sequence/loop)</td> <td data-bbox="1161 1664 1375 1783">(On as reqd. basis subject to 100 minimum)</td> </tr> <tr> <td data-bbox="497 1783 603 1877">b)</td> <td data-bbox="603 1783 1161 1877">P&ID/ mimic display</td> <td data-bbox="1161 1783 1375 1877">100</td> </tr> </tbody> </table>			a)	Control displays (group/sub-group/sequence/loop)	(On as reqd. basis subject to 100 minimum)	b)	P&ID/ mimic display	100	
a)	Control displays (group/sub-group/sequence/loop)	(On as reqd. basis subject to 100 minimum)								
b)	P&ID/ mimic display	100								
<p>SINGRAULI STPP STAGE-III (1X500 MW) EPC PACKAGE</p>		<p>TECHNICAL SPECIFICATION SECTION-VI PART-B</p>	<p>SUB-SECTION-C-12(B) PLANT AUXILIARY SYSTEM</p>	<p>PAGE 9 OF 13</p>						

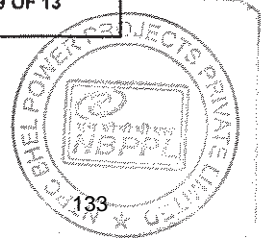

CLAUSE NO.	TECHNICAL REQUIREMENTS			एनटीपीसी NTPC
	c)	Bar chart	30	<p>The assignment for the above will be done by the contractor as per the requirement of operation of Contractor's system as well as for maintenance. The balance displays shall be left as spare for future modification/addition.</p>
	d)	X-T Plot	30	
	e)	X-Y Plot (with superimposed operating curves + using user selectable stored data)	25 + 25	
	f)	Group displays	30	
	g)	Operator guidance message	10	
	h)	System status & other diagnostic display	on as required basis	
8.00.00	HISTORICAL STORAGE AND RETRIEVAL SYSTEM (HSRS)			
8.01.00	The HSRS shall collect store and process system data from MMIPIS data base. The data shall be saved online on hard disk and automatically transferred to erasable long term storage media once in every 24 hours periodically for long term storage. Provision shall be made to notify the operator when hard disk is certain percentage full. The disk capacity shall be sufficient to store at least seven days data.			
8.02.00	The data to be stored in the above system shall include alarm and event list, periodic plant data, selected logs/reports. The data/information to be stored & frequency of storage and retrieval shall be as finalised during detailed engineering. The system shall provide user-friendly operator functions to retrieve the data from historical storage. It shall be possible to retrieve the selected data on OWS or printer in form of trend/report by specifying date, time & period. Further, suitable index files/directories shall also be provided to facilitate the same. The logs/reports for at least last seven (7) days shall be available on the disk.			
8.03.00	In addition to above, the system shall also have facility to store & retrieve important plant data for a very long duration (plant life) on portable long term storage media). These data will include any data from the database as well as processed/computed data based an various calculations/transformation. The retrieved data from long term storage media should be possible to be presented in form of X-T display, X-Y display, logs, reports, etc.			
9.00.00	CONTROL & POWER SUPPLY SCHEME			
9.01.00	<p>General Requirements</p> <p>Necessary redundant transformers and redundant chargers with 24 V DC battery back-up shall be provided by the Contractor to derive power supply from 415V, 3-phase 3-wire incomers to be arranged by the Contractor at the input terminals of power supply cabinets. The Contractor shall, however furnish all required hardware/ equipment/ cubicles for conversion and/or stabilization of the power source provided</p>			
SINGRAULI STPP STAGE-III (1X500 MW) EPC PACKAGE	TECHNICAL SPECIFICATION SECTION-VI PART-B	SUB-SECTION-C-12(B) PLANT AUXILIARY SYSTEM	PAGE 10 OF 13	

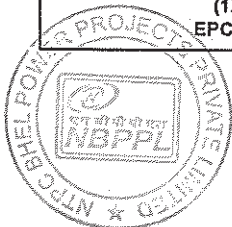

CLAUSE NO.	TECHNICAL REQUIREMENTS		
	<p>by the Owner to all other levels which may be necessary for meeting the individual requirements of equipments/ systems furnished by him within the Contractor's quoted lump sum price.</p> <p>The 24 V DC power supply system configuration shall be provided as per Appendix-1, section VI, Part – A of specifications</p>		
10.00.00	CONTROL CABINETS / PANELS		
10.01.00	<p>The cabinets shall be IP-22 protection class. The Contractor shall ensure that the packaging density of equipment in these cabinets is not excessive and abnormal temperature rise, above the cabinet temperature during normal operation or air-conditioning failure, is prevented by careful design. This shall be demonstrated to the Employer during the factory testing of the system. The Contractor shall ensure that the temperature rise is limited to 10 deg. C above ambient and is well within the safe limits for system components even under the worst condition as specified in Sub-section-basic Design criteria (Part-B, Section-VI) and specification requirements for remote I/O cabinets. Ventilation blowers shall be furnished as required by the equipment design and shall be sound proof to the maximum feasible extent. If blowers are required for satisfactory system operation, dual blowers with blower failure alarm shall be provided in each cabinet with proper enclosure and details shall be furnished with proposal. Suitable louvers with wire mesh shall be provided on the cabinet.</p>		
10.01.01	<p>The cabinets shall be designed for front access to system modules and rear access to wiring and shall be designed for bottom entry of the cables.</p>		
10.01.02	<p>The cabinets shall be totally enclosed, free standing type and shall be constructed with minimum 2 mm thick steel plate frame and 1.6 mm thick CRCA steel sheet or as per supplier's standard practice for similar applications, preferred height of the cabinet is 2200 mm. The cabinets shall be equipped with full height front and rear doors. The floor mounting arrangement for other cabinets shall be as required by the Employer and shall be furnished by the Contractor during detailed engineering.</p>		
10.01.03	<p>Cabinet doors shall be hinged and shall have turned back edges and additional bracing where required ensuring rigidity. Hinges shall be of concealed type. Door latches shall be of three-point type to assure tight closing. Detachable lifting eyes or angles shall be furnished at the top of each separately shipped section and all necessary provisions shall be made to facilitate handling without damage. Front and rear doors shall be provided with locking arrangements with a master key for all cabinets. If width of a cabinet is more than 800 mm, double doors shall be provided.</p>		
10.01.04	<p>Two spray coats of inhibitive epoxy primer-surface shall be applied to all exterior and interior surfaces. A minimum of 2 spray coats of final finish colour shall be applied to all surfaces. The final finished thickness of paint film on steel shall not be less than 65-75 micron for sheet thickness of 2 mm and 50 microns for sheet thickness of 1.6 mm. The finish colors for exterior and interior surfaces shall conform to following shades:</p> <p>(a.) Exterior:- As per RAL 9002 (End panel sides RAL 5012), to be finalized during detailed engineering.</p> <p>(b.) Interior:- Same as above.</p>		
SINGRAULI STPP STAGE-III (1X500 MW) EPC PACKAGE	TECHNICAL SPECIFICATION SECTION-VI PART-B	SUB-SECTION-C-12(B) PLANT AUXILIARY SYSTEM	PAGE 11 OF 13

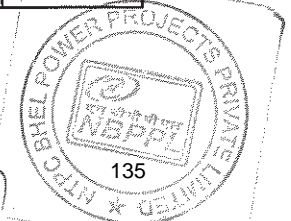

08652

CLAUSE NO.	TECHNICAL REQUIREMENTS		
10.01.05	Paint films which show sags, checks or other imperfections shall not be acceptable.		
10.01.06	As an alternative, single coat of anodic dipcoat primer along with single textured powder coating with epoxy polyester meeting the thickness requirement is also acceptable.		
10.01.07	Refer Subsection Basic Design Criteria, Part B, and Section VI for grounding requirements.		
10.01.08	The mimic shall be configured on the OWS and it shall be possible to control, monitor and operate the plant from the same.		
10.01.09	The technical specification covering panel fabrication details, wiring and termination details etc. shall be as described under Sub-Section INST CABLE of this specification.		
11.00.00	ANNUNCIATION SYSTEM		
11.01.00	Only OWS based alarm system shall be provided with audio alarm facility (beep/tone generator). No facia annunciation is envisaged in the control room. Hooters are to be provided.		
11.02.00	The system shall display history of alarms in chronological order on any of the OWS. The HMIS shall have the capability to store a minimum of 500 alarms each with paging features allowing the operator to view any page. The system shall have all alarm functions and related function keys like alarm acknowledge, reset, paging, summaries etc. Other design features like set point/dead band adjustments, provision of alarm priority, manual inhibition & automatic inhibition based on predefined logic etc., shall be provided and shall be as finalised during detailed engineering. The alarm display/report format shall be as approved by the Employer.		
11.03.00	Facility of audio annunciation shall be provided in OWS upon the occurrence OWS alarms irrespective of whether alarms are displayed or not. Facility to disable the audio annunciation shall be provided.		
11.04.00	At least three levels of alarm priority shall be available which will be displayed in different colour. It shall be possible to display & print alarms of any of the three levels.		
11.05.00	The annunciator sequence shall conform to ISA sequence ISA-2A..		
12.00.00	SOFTWARE DOCUMENTATION AND SOFTWARE LISTINGS		
12.01.00	All technical manuals, reference manuals, user's guide etc., in English required for modification/editing/addition/deletion of features in the software of the PLC System shall be furnished. The Contractor shall furnish a comprehensive list of all system/application software documentation after system finalization for Employer's review and approval.		
12.02.00	All The software listings including Source code for application software, All special - to-project data files etc. shall be submitted by the Contractor.		
SINGRAULI STPP STAGE-III (1X500 MW) EPC PACKAGE	TECHNICAL SPECIFICATION SECTION-VI PART-B	SUB-SECTION-C-12(B) PLANT AUXILIARY SYSTEM	PAGE 12 OF 13

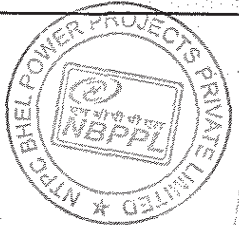

08653

CLAUSE NO.	TECHNICAL REQUIREMENTS		
13.00.00	<p>SOFTWARE LICENCES</p> <p>The Contractor shall provide software license for all software being used in Contractor's System. The software licenses shall be provided for the project (e.g. organisation or site license) and shall not be hardware/machine-specific. That is, if any hardware/machine is upgraded or changed, the same license shall hold good and it shall not be necessary for Employer to seek a new license/renew license due to upgradation/change of hardware/machine in Contractor's System at site. All licenses shall be valid for the continuous service life of the plant.</p> <p>As a customer support, the Contractor shall periodically inform the designated officer of the Employer about the software upgrades/new releases that would be taking place after the system is commissioned so that if required, same can be procured & implemented at site.</p>		
14.00.00	<p>For the Specification of OWS, GIU, printer and other Human Machine interface items please refer Part-B, Sub-Section-C02, DDCMIS of Technical Specification.</p>		
SINGRAULI STPP STAGE-III (1X500 MW) EPC PACKAGE	TECHNICAL SPECIFICATION SECTION-VI PART-B	SUB-SECTION-C-12(B) PLANT AUXILIARY SYSTEM	PAGE 13 OF 13

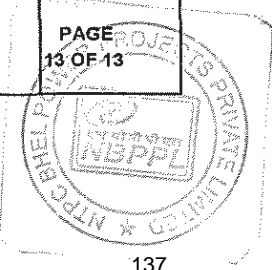

SPECIFICATION OF MASTER & SLAVE CLOCK SYSTEM, GIU, PRINTER, PC, ETHERNET SWITCHES

08405

CLAUSE NO.	TECHNICAL REQUIREMENTS		
<p>1.00.00</p> <p>1.01.00</p>	<p>Requirements for Master & Slave Clock System (Refer sub section- scope of supply & services for applicability of this annexure)</p> <p>MASTER & SLAVE CLOCK SYSTEM</p> <p>Master and Slave clock system shall be provided to ensure uniform time indication throughout the various plants facilities and time synchronization between various systems as detailed in Sub-section II Scope of Supply and Services.</p> <p>The Contractor shall provide a GPS based date insensitive master and slave clock system (common for the station) with adequate number of output signal to provide uniform timing throughout the various plant facilities supplied by Contractor as well as those not in Contractor's scope. The system shall be complete with receiving antennae (for receiving time from GPS & Radio signal), receiver and associated electronics, Redundant Master Clocks, Slave Clocks, interconnecting cables, cubicles, power supplies & any other accessories. However, a provision shall be kept for synchronisation of the master clock with other source as decided during detailed Engineering. The exact format/type of synchronisation of master clock with other sources & slave/other system with master clock shall be finalised during detailed Engg. Stage.</p> <p>The Master Clock shall drive the slave display units. It shall be ensured that loss of any slave display unit does not affect the display of any other slave unit. The character size of slave display unit shall be 100 mm.</p> <p>Since the timing synchronization of many off-site facilities are being done through station LAN, the slave clocks may be alternatively driven by respective systems/sub-systems.</p> <p>The master slave clock shall also meet the redundancy requirements specified in Cl 1.06.05 of subsection IIIC-02 for controllers, servers etc.</p> <p>The master clock shall have facility for automatic synchronising with radio & other external signals also.</p> <p>All the cables for interconnection between Master Clock and Slave Clocks & other systems shall be under Contractor's Scope. This will include all signal cables, (minimum Type-G cable as per Sub-section Instrumentation cable, Part-B Section-VI) as well as power supply cables if separately required.</p> <p>In the Main Plant area, Power supply for the slave clocks and master clock system shall be arranged by Contractor. In remote Offsite areas, slave clocks shall be powered from 240 V AC supply available at those locations. All the power supply cables, MCBs, erection hardware etc. required for powering Slave Clock form Employer furnished 240 V AC Supply shall be in the scope of Contractor.</p> <p>The inputs & outputs of the Master Clock (i.e. the source signals & the consumer signals for synchronization) are defined in Appendix-I to Part-A. (Contract quantities).</p>		
<p>SINGRAULI STPP STAGE-III (1X500 MW) EPC PACKAGE</p>	<p>TECHNICAL SPECIFICATION SECTION-VI PART-B</p>	<p>ANNEXURE -C-02F MASTER & SLAVE CLOCK</p>	<p>PAGE 1 OF 2</p>

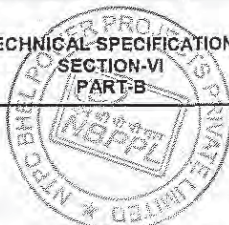

08406

CLAUSE NO.	TECHNICAL REQUIREMENTS		
	<p>Type of the output for each consumer shall be as finalised during detailed engineering.</p> <p>Software package for Time synchronization of Master slave clocks and station LAN.</p> <p>Software licences as applicable shall be provided for time synchronization of Master slave clocks and station LAN functionality as provided for other software listed at 10.04.00(b).</p>		
<p>SINGRAULI STPP STAGE-III (1X500 MW) EPC PACKAGE</p>	<p>TECHNICAL SPECIFICATION SECTION-VI PART-B</p>	<p>ANNEXURE -C-02F MASTER & SLAVE CLOCK</p>	<p>PAGE 2 OF 2</p>

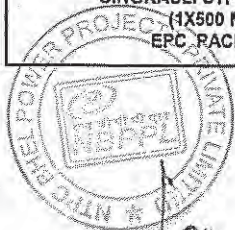

CLAUSE NO.	TECHNICAL REQUIREMENTS																																															
<p>1.01.09</p> <p>Graphical Interface Unit</p> <p>Minimum specifications of Graphical Interface unit shall be as follows:-</p> <table border="1" data-bbox="432 678 1417 1379"> <thead> <tr> <th>Sl no.</th> <th>Features</th> <th colspan="2">Description</th> </tr> </thead> <tbody> <tr> <td>1.</td> <td>Power supply</td> <td colspan="2">230 V AC</td> </tr> <tr> <td>2.</td> <td>Display Size & Type</td> <td colspan="2">10-11 inch & Color, TFT screens</td> </tr> <tr> <td>3.</td> <td>Humidity</td> <td colspan="2">5-95%</td> </tr> <tr> <td>4.</td> <td>Protection class</td> <td colspan="2">IP-65 for extremely dust prone area, otherwise IP-55. Enclosure shall be provided to prevent ingress of dust.</td> </tr> <tr> <td>5.</td> <td>Keys</td> <td colspan="2">Function keys and numeric keys</td> </tr> <tr> <td>6.</td> <td>Interfacing requirements</td> <td colspan="2">Interface with respective control systems</td> </tr> <tr> <td>7.</td> <td>Functional requirements</td> <td colspan="2"> Ability to operate drives locally using function keys. Ability to do programming. Graphics display including alarms and operator guidance messages. </td> </tr> </tbody> </table>	Sl no.	Features	Description		1.	Power supply	230 V AC		2.	Display Size & Type	10-11 inch & Color, TFT screens		3.	Humidity	5-95%		4.	Protection class	IP-65 for extremely dust prone area, otherwise IP-55. Enclosure shall be provided to prevent ingress of dust.		5.	Keys	Function keys and numeric keys		6.	Interfacing requirements	Interface with respective control systems		7.	Functional requirements	Ability to operate drives locally using function keys. Ability to do programming. Graphics display including alarms and operator guidance messages.		<p>14. Contractor shall include for each LVS, supply of lamps for three (3) years after the completion of the warranty period, based on the average life of the lamps, as per the Contractor's published literature. It during the warranty period, it is found that lamps are consumed at faster rate than the published average life of the lamps, the Contractor shall augment the quantity of the three years supply of lamps accordingly. (As a minimum for each LVS, Contractor shall supply 150% lamps with respect to the no. of lamps used in each LVS).</p> <p>1.01.10</p> <p>Printers</p> <table border="1" data-bbox="432 1451 1417 1720"> <thead> <tr> <th>Sr. No</th> <th>Features</th> <th>Colour Laser Printer</th> <th>Colour Laser Printer</th> <th>Line Impact Dot Matrix Printer</th> </tr> </thead> <tbody> <tr> <td>1</td> <td>Paper Size</td> <td>A3</td> <td>A4</td> <td>132 column continuous fan fold type</td> </tr> <tr> <td>2</td> <td>Printing Speed</td> <td>6 ppm (Color)</td> <td>4 ppm (color)</td> <td>1000 LPM</td> </tr> </tbody> </table>	Sr. No	Features	Colour Laser Printer	Colour Laser Printer	Line Impact Dot Matrix Printer	1	Paper Size	A3	A4	132 column continuous fan fold type	2	Printing Speed	6 ppm (Color)	4 ppm (color)	1000 LPM
	Sl no.	Features	Description																																													
1.	Power supply	230 V AC																																														
2.	Display Size & Type	10-11 inch & Color, TFT screens																																														
3.	Humidity	5-95%																																														
4.	Protection class	IP-65 for extremely dust prone area, otherwise IP-55. Enclosure shall be provided to prevent ingress of dust.																																														
5.	Keys	Function keys and numeric keys																																														
6.	Interfacing requirements	Interface with respective control systems																																														
7.	Functional requirements	Ability to operate drives locally using function keys. Ability to do programming. Graphics display including alarms and operator guidance messages.																																														
Sr. No	Features	Colour Laser Printer	Colour Laser Printer	Line Impact Dot Matrix Printer																																												
1	Paper Size	A3	A4	132 column continuous fan fold type																																												
2	Printing Speed	6 ppm (Color)	4 ppm (color)	1000 LPM																																												
<p>SINGRAULI STPP STAGE-III (1X500 MW) EPC PACKAGE</p>	<p>TECHNICAL SPECIFICATION SECTION-VI PART-B</p>	<p>ANNEXURE - C-02G HMI HARDWARE</p>	<p>PAGE 6 OF 12</p>																																													

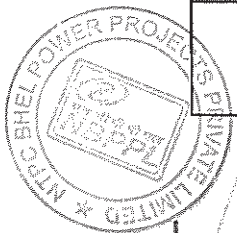

08414

CLAUSE NO.	TECHNICAL REQUIREMENTS			
1.01.11	(min.)- in normal mode for A4 size paper 3 Type 4 Resolution (black) (min.) 5 First page out time (with full graphic display) 6 Paper input capacity (min.) 7 Additional features 8 Paper sheets (1 ream = 500 sheets) with each printer 9 Additional Cartridge/toner/ ribbon of each type as used in printer with each printer Specification of PC The minimum requirement for PC shall be as below: CPU Latest generation CPU	24 ppm (B&W) Heavy duty, at least 50000 pages/month 600 dpi =<1 min for color, <45 sec for BW 500 sheets Automatic Duplex Printing 20 reams (A3) 20 reams (A4)	16 ppm (B&W) Heavy duty, at least 30000 pages/month 600 dpi =<1 min for color, <45 sec for BW 500 sheets Automatic Duplex Printing 20 reams (A4) 1	Heavy duty, at least 50000 pages/month - Continuous paper feed With printer Stand & sound proof enclosure (<60 dB) 20 reams (132 column fan-fold) 100
SINGRAULI STPP STAGE-III (1X500 MW) EPC PACKAGE	TECHNICAL SPECIFICATION SECTION-VI PART-B	ANNEXURE - C-02G HMI HARDWARE	PAGE 7 OF 12	

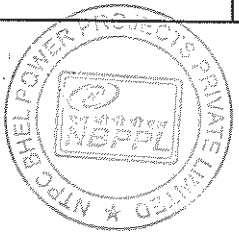

08415

CLAUSE NO.	TECHNICAL REQUIREMENTS		
1.01.12	<p>Main memory</p> <p>Drives</p> <p>Hard disk</p> <p>Monitor</p> <p>Graphic Memory</p> <p>Communication port</p> <p>Expansion slots</p> <p>Other Features</p> <p>UPS</p> <p>Accessories</p> <p>Software</p> <p>The list of PC stations, their location in plant and purpose shall be as per Appendix-I to Part-A (Annexure-I to Contract quantities for DDCMIS). All the PC stations shall be connected to Unit LAN/Station LAN.</p> <p>It shall be possible to access any information of HMIPIS data base along with operator functionality (with General purpose rights as defined in table titled SECURITY LEVELS IN HMIPIS) like mimics, logs, trends etc. from the PC station given below. To achieve this, recreation of graphics, logs & other application need not be required. Also any modification etc done in any mimic etc. need not be separately done for these stations. Therefore suitable provisions (including adequate no of OWS-license), if required shall be provided. However, normally the access will be for the purpose listed in Appendix-II to Part-A.</p> <p>Specification for Lap-Top (Note-Book) PC</p> <p>Core 2 duo latest version or better network-ready lap-top PC with 15.4 inch wide</p>	<p>1GB expandable to 4 GB</p> <p>DVD read/write drive</p> <p>80 GB</p> <p>19" Full Flat TFT, refresh rate min 75 Hz</p> <p>16 MB</p> <p>2 serial plus, one parallel, 1 USB port, Dual 100 Mbps Ethernet</p> <p>3</p> <p>101 Keys Keyboard and Optical Mouse</p> <p>1 no. on-line Intelligent UPS with 30 mins. Battery backup on machine load (for PC & its printer) and remote monitoring are to be provided for each PC.</p> <p>Industrial grade furniture (computer table & chair) for PC & its printer, as approved during detailed engineering.</p> <p>a General MS Windows latest, MS-Office, Microsoft Visual Studio, Adobe Acrobat, anti-virus McAfee or equivalent, etc.</p> <p>b Application software - to suit project specific requirement</p>	
SINGRAULI STPP STAGE-III (1X500 MW) EPC PACKAGE	TECHNICAL SPECIFICATION SECTION-VI PART-B	ANNEXURE - C-02G HMI HARDWARE	PAGE 8 OF 12

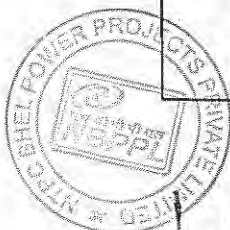

CLAUSE NO.	TECHNICAL REQUIREMENTS		
1.01.13	<p>screen TFT LCD, 2 GB RAM, 52x Combo CD/DVD RW drive, hard disk of 120 GB built in MODEM with software as specified above for PCs shall be provided. All the Lap top PC will also be used as pluggable temporary programmer's station and operator station functionalities of the programming stations mentioned in the specific shall be provided (including requisite license).</p> <p>It may be noted that the specifications for PCs/Laptop under the above clauses are indicative. The PCs/Laptop to be provided by the Contractor should be latest available in the market at the time of supply to prevent early obsolescence and shall be subject to Employer's approval. The software packages to be included with the PCs shall also be the latest version available at the time of supply.</p> <p>Switches :</p> <p>Layer-3 switches shall have the following features:</p> <ul style="list-style-type: none"> ● 48 X Gigabit Ethernet Port ● 24 or 48 x 10/100/1000 Base TX ports (STP) ● SNMP, RMON, VOIP, VLAN, Multi link Trunk support ● Broadcast/multicast storm control ● Supervisor Engine redundancy capability ● Redundant Power Supply ● Extra expansion slots for future up gradation. ● Integrated Security features (IPS, ACL, Firewall) ● 10 GB module support for future upgradeability <p>Expandability/stackability through a dedicated high speed expansion port. Routable, remotely manageable, configurable.</p> <p>One intelligent SNMP manageable mini-UPS for 30 minutes backup shall be provided with all accessories and software.</p> <p>Secondary switches shall have the following features:</p> <ul style="list-style-type: none"> ● 24 or 48 X 10/100/1000 Base TX ports (STP) ● 2 or 4 X Gigabit Ethernet Port ● SNMP, RMON, VOIP, VLAN, Multi link Trunk support. ● Support for stacking with high throughput ● Broadcast/multicast storm control 		
SINGRAULI STPP STAGE-III (1X500 MW) EPC PACKAGE	TECHNICAL SPECIFICATION SECTION-VI PART-B	ANNEXURE - C-02G HMI HARDWARE	PAGE 9 OF 12



CLAUSE NO.

TECHNICAL REQUIREMENTS

06486



	CR			c. Locker set	1 each
				d. Computer table	1 each
14	CWT / CW CHLOR RIO Room	-	-	a. Chair	1 each
				b. Computer table	1 each
15	CSSP RIO Room	-	-	a. Chair	1 each
				b. Computer table	1 each
16	Mill reject Control room			a. Chair	3 each
				b. Key pad	1 each
				c. Locker set	1 each
17	Fuel Oil pump house control room			a. Chair	3 each
				b. Key pad	1 each
				c. Locker set	1 each
				d. Computer table	1 no. to accommodate 2 OWS
18	Hydrogen Generation Plant			a. Chair	3
				b. Key pad	1
				c. Locker set	1

Note1(*):-The quantity of various items indicated above are as follows. The quantity of UCD and furniture for S. No. 1 to 3 above shall be 1 set for each generating unit and for balance it shall be 1 set for station (i.e., common for all generating units).

Note 2:- Provision for Monitors, mice, keyboards on each CD: (i) As per OWS/LVS count and HMI specification for various control areas (ii) For UCD: As per OWS/LVS count and HMI specification for Unit AND 2 Nos. monitors for SG & TG controls (under Employer's scope) AND one no. synchroscope plaque.

Note 3: Provision for no. of Monitors, mice, keyboards in each Unit-in-charge desk (UID): 2 nos./ unit

Note-4: Draw-out section/plaque shall be provided in UCD and CD for CHP as follows:

(A) UCD:

(i) One no. draw out section for process side - 16(h)X10(w) mosaic tiles, each of size 48 mm x 24 mm or 50 mm x 25 mm.

(ii) One no. draw out section for electrical side - 20(h)X13(w) mosaic tiles, each of size 48 mm x 24 mm or 50 mm x 25 mm.

SINGRAULI STPP STAGE-III
(1X500 MW)
EPC PACKAGE

INSTRUMENT AND CONTROL
DEVICE LIST
APPENDIX-I TO PART-A

CONTRACT QUANTITIES
FOR UCD AND PANELS

PAGE
4 OF 6

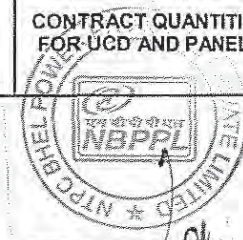

CLAUSE NO.	TECHNICAL REQUIREMENTS			
1.01.00	<p style="text-align: right; margin-right: 50px;">06480</p> <p>GENERAL REQUIREMENTS</p> <ol style="list-style-type: none"> 1. Input/output signal multiplication, and distribution of process, system and software generated points, etc. required within the TG C&I system are to be provided by the Contractor on as required basis. 2. For signal exchange with BOP C&I systems and TG C&I Systems [for information only, Contractor shall provide suitable data link/interface. However signals required to be exchanged between SG/BOP C&I systems for protection of Turbine, Boiler and other HT drives as well as for CMC shall be hardwired. The same shall be provided on as required basis. 3. The quantity of drive related inputs and outputs shall be derived from the Table 1: NO.OF INPUTS/OUTPUTS FOR DRIVES by the Bidder and the quantity of input/output modules shall be decided accordingly. 4. Bidder shall identify in his offer the different types of I/O modules offered by him which as per him are having directly or otherwise an I/O capability, (e.g., Analog input/output module, binary input/output module, etc.). However, the Contractor shall note that all such offered modules having I/O capability shall be acceptable only if they meet all the functional and hardware requirements of I/O modules as specified elsewhere. 5. The I/Os for common systems shall be provided only for one unit and for balance units these I/Os need not be provided. 6. Required Limit switch contacts of valves/dampers, breaker/contactors status contacts & other inputs etc. shall be fed as inputs to Control System at one place. The Contractor shall distribute these inputs within Control System or other places wherever required for commands, status indication, interlock and protection of drives, sequence logic, loops & other functions. 7. The spare capacity for the system shall be included and provided by the Contractor. 8. Suitable devices (like diodes, etc) are to be provided, if required, for signals which are to be shared between more than one I/O modules. 9. (i) In the Table "Drive I/Os", wherever contact type binary outputs are specified (which are applicable for drives specified in Table-I), relays are to be provided. These relays shall be driven by 24 V DC command outputs through DO modules. In case redundancy in outputs of these types is required, redundancy shall be provided only in DO modules, but not for the relays. (ii) The power supply for energizing such drives in the field shall be routed through contacts of the above mentioned relays. The monitoring of power supply extended through contacts of the relays shall be done for a group of drives. The no. of drives per group can be maximum 4. One contact of power supply monitoring device (relay/ MCB with contact or equivalent scheme, as approved by Employer during detailed engg. stage) shall be wired to DDCMIS, and the same shall be used for 'drive disturbance' for all the drives in the group. 			
SINGRAULI STPP STAGE-III (1X500 MW) EPC PACKAGE	INSTRUMENT AND CONTROL DEVICE LIST APPENDIX-I TO PART-A	APPENDIX-I-TG	PAGE 2 OF 4	

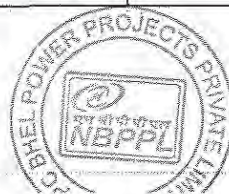



- 10. Redundancy in binary outputs for drives shall be provided for only HT, HTCHP & VFD types of drives. For DDCMIS, in each functional group, redundancy shall be provided for 10% of all the binary outputs for drives in the functional group. (Exact application shall be finalized during detailed engg.)
- 11. Redundancy in analog outputs shall be provided for 10% of CLCS drives in each functional group for DDCMIS. (Exact application shall be finalized during detailed engg.)
- 12. The contact rating of "DO (contact)" type outputs indicated in Table-IA/IB (field I/Os) shall be as follows. The contact rating for such outputs for Unit DDCMIS shall be minimum 60VA, and shall be suitable for contact interrogation at 24 V DC. For such outputs for other DDCMIS systems relays shall be provided for each of such outputs.
- 13. Field-bus compatible temperature transmitter shall be provided for Gen. Temperature monitoring.
- 14. All the remote I/O locations are air conditioned. The field bus compatible temperature transmitters, shall be located in non-air conditioned outdoor locations.
- 15. Additional note for Table "Drive I/Os"
 - (*) The on/off status of HT drives of Unit DDCMIS will be wired to DI modules in parallel. The open/ close status of sync type electrical breakers of Unit DDCMIS will be connected in parallel to DI and DISOE modules.
 - (**) The 2 signals of HT drives & sync type electrical breakers of DDCMIS are to be connected to DISOE module; for HT drives & sync type electrical breakers in other DDCMIS these will be connected to DI module.

2.00.00

LIST OF AREAS FOR WHICH SOFT SIGNALS IS TO BE CONNECTED TO TG C&I

Sl no.	Area	Connected to the DDCMIS System	Minimum Qty of links/ Location	Type	Qty of signals
1.	TG Charger in each unit	TG C&I of respective unit	04 Nos. / Charger Room per unit	RS 485 / RS232	20 per charger
2.	Generator Temps	TG C&I of respective unit	As on required basis	Field Bus/Profibus/Remote I/O (4-20mA signals only.	As on required basis

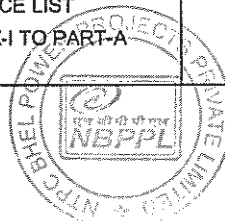

CLAUSE NO.

TECHNICAL REQUIREMENTS

06482



3.00.00

PLC based Control Systems

SI no	Area	Description of Control system
1.	Hydrogen Generation Plant	Microprocessor/PLC based Control system as per manufacturer's standard practice with redundant cold stand-by processor.

4.00.00

For the items like Measuring Instruments, Process Connection and piping, Control Valves and Actuators, Other TG C&I systems, and Instrumentation and Power supply cables, contract quantities shall be on as required basis.

SINGRAULI STPP STAGE-III
(1X500 MW)
EPC PACKAGE

INSTRUMENT AND CONTROL
DEVICE LIST
APPENDIX-I TO PART-A

APPENDIX-I-TG

PAGE
4 OF 4

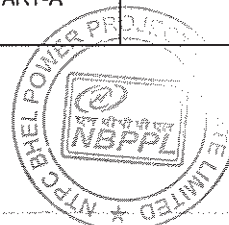

08634

CLAUSE NO.	TECHNICAL REQUIREMENTS	
8.02.00	<p>Provision shall be made to notify the operator when hard disk is certain percentage full. The disk capacity shall be sufficient to store at least seven days data .</p> <p>The data to be stored in the above system shall include alarm and event list, periodic plant data, selected logs/reports . The data/information to be stored & frequency of storage and retrieval shall be as finalised during detailed engineering. The system shall provide user-friendly operator functions to retrieve the data from historical storage. It shall be possible to retrieve the selected data on OWS or printer in form of trend/report by specifying date, time & period. Further, suitable index files/directories shall also be provided to facilitate the same. The logs/reports for at least last seven (7) days shall be available on the disk.</p>	
8.03.00	<p>In addition to above, the system shall also have facility to store & retrieve important plant data for a very long duration (plant life) on portable long term storage media). These data will include any data from the database as well as processed/computed data based an various calculations/transformation. The retrieved data from long term storage media should be possible to be presented in form of alarms, logs, reports, etc.</p>	
9.00.00	<p>CONTROL & POWER SUPPLY SCHEME</p>	
9.01.00	<p>General Requirements</p> <p>Necessary redundant transformers and redundant chargers with 24 V DC battery back-up shall be provided by the Contractor to derive power supply from 415V, 3-phase 3-wire incomers to be arranged by the Contractor at the input terminals of power supply cabinets. The Contractor shall, however furnish all required hardware/equipment/ cubicles for conversion and/or stabilization of the power source provided by the Owner to all other levels which may be necessary for meeting the individual requirements of equipments/ systems furnished by him within the Contractor,s quoted lumpsum price.</p> <p>24 V DC power supply system shall be provided as below:-</p> <ul style="list-style-type: none"> i) Power supply for each PLC based control systems and each remote I/O system shall comprise of two sets, each set shall consist of 1 x 100% microprocessor controlled, intelligent, modular rectifier banks, Controller –one for each rectifier bank, 1 x 100% Nickel - Cadmium batteries for one (1) hour duty, 1 X 100% DC distribution board ii) One set of 24V DC power supply system for each Fire alarm panel and Repeater fire alarm panel with 12 hours battery back up as per manufacturer's standard practice. 	
9.02.00	<p>POWER SUPPLY SYSTEM FOR PLC BASED CONTROL PANELS</p>	
9.02.01	<p>Microprocessor based, Intelligent, Modular Power Supply</p>	
9.02.02	<p>Microprocessor based, intelligent, modular power supply shall be sized to meet connected load requirements and keep the connected battery full charged in Float / Boost mode. Either of the bank of rectifier modules shall be able to re-charge the fully discharged battery within 8 hours automatically on-line. It shall also be possible</p>	
<p>SINGRAULI STPP STAGE-III (1X500 MW) EPC PACKAGE</p>	<p>TECHNICAL SPECIFICATION SECTION - VI PART-B</p>	<p>SUB-SECTION-C-12(A) PLC BASED CONTROL SYSTEM</p> <p>PAGE 11 OF 16</p>

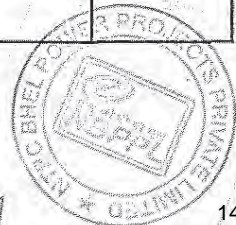

08635

CLAUSE NO.	<p style="text-align: center;">TECHNICAL REQUIREMENTS</p> 
	<p>to discharge batteries periodically manually. Each rectifier bank shall have minimum 3 nos. rectifier modules for all applications. Each rectifier module shall be of minimum 10% rating of the total capacity for Control system loads. The exact sizing of the rectifiers in one bank shall be as approved by Employer during detailed engineering. Provision shall be available to add new modules in each rectifier cabinet for future use. While selecting the components and finalizing the cooling arrangements, Bidder to note that these rectifier modules are required to operate at 30-40 % of the rated load for most of the time.</p>
9.02.03	<p>The rectifier module shall be microprocessor controlled, IGBT/Power MOSFET based, high frequency with active load sharing, designed for single and parallel operation with battery and shall have automatic voltage regulators for a close voltage stability even when AC supply voltage and DC load fluctuates, effective current limiting features, front access design, programmable temperature compensation feature for battery charging and filters on both input and output to minimize harmonics. The rectifier module output regulation shall be +/- 1% or better from no load to full load with an input power supply variation of +/- 10% in voltage and +/- 5% in frequency. In addition to indications / display on rectifier panel, potential free contacts for alarms like O/P voltage high & low, battery isolated, multiple rectifier modules failed, AC input supply out of specified range, communication fault, battery fuse blown, surge protection failure, controller faulty but system running, system overload, etc. shall also be provided for use in PLC system. Further isolated 4-20 mA signals shall be provided for important parameters like rectifier module voltage etc. The list of alarm output & 4-20 mA signals shall be as approved by Employer during detailed engineering. RS 485 Port Modbus Protocol / Ethernet TCP / IP protocol for communication with control system shall also be provided. Necessary provision shall be done in PLC end also.</p>
9.02.04	<p>"Float / Boost" charge functions shall be provided with alarm / indications.</p>
9.02.05	<p>Each rectifier bank shall be rated for 100% load requirement and keep the connected battery full charged and one spare rectifier module.</p>
9.02.06	<p>The rectifier module circuitry shall be of fail-safe design and failure of any component should not result in any rectifier bank output voltage to increase beyond acceptable limits of the C&I system being fed from it.</p>
9.02.07	<p>The rectifier module shall be current limited for circuit protection and protection of battery from overcharge. The current limit shall be continuously programmable.</p>
9.02.08	<p>The rectifier module shall have a slow walk-in circuit which shall prevent application of full load DC current in less than 10 seconds after AC power is energized.</p>
9.02.09	<p>The rectifier module shall be fed from 415 V AC, 50 HZ, 3 phase, 3 wire system. The Bidder shall provide all required power cables & other accessories etc. from 415 V AC power supply system to his electrical power supply system.</p>
9.02.10	<p>The full load efficiency at nominal input and output shall be 90%. The ripple content shall be limited to +/- 0.5% of output voltage.</p>

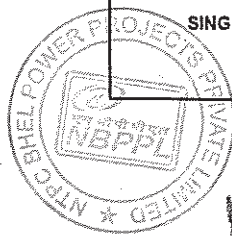

<p>SINGRAULI STPP STAGE-III (1X500 MW) EPC PACKAGE</p>	<p>TECHNICAL SPECIFICATION SECTION - VI PART-B</p>	<p>SUB-SECTION-C-12(A) PLC BASED CONTROL SYSTEM</p>	<p>PAGE 12 OF 16</p>
--	--	---	--------------------------

08636

CLAUSE NO.	TECHNICAL REQUIREMENTS		
9.02.111	The rectifier module design shall ensure that there is no component failure due to fluctuation of input supply or loss of supply and restoration. This feature shall be demonstrated during factory testing at various loads.		
9.02.112	Bidder shall furnish the equipment complete in all respect along with rectifier module rating & voltage drop calculations, supporting curves / data etc.		
9.02.13	The Controller shall be intelligent, microprocessor controlled for monitoring & control of rectifier modules with features viz. auto / manual battery discharge test, battery reserve time prediction, energy management, remote control, float / boost mode control etc.		
9.02.14	All software as required for smooth operation and monitoring of rectifier modules in conjunction with controller & BHMS shall be provided by the Contractor.		
9.03.00	Batteries for PLC system		
9.03.01	The batteries for PLC systems shall be heavy duty Nickel – cadmium type and shall be sized for one hour of full load operation during non-availability of AC supply / chargers. The Ni-cd batteries shall conform to IS: 10918. For sizing calculation, an aging factor of 0.8 and a temperature correction factor of 0.935 (based on temperature of 4 deg. C). Capacity factor shall be taken into consideration, if applicable and ambient temperature shall be considered as the electrolytic temperature. The sizing of the battery shall be as approved by Employer during detailed engineering. The system shall also be suitably designed to overcome any over voltage that may arise during low-load operation of the rectifier modules.		
9.04.00	DC DISTRIBUTION BOARD (DCDB) Redundant DC feeders (one from each DCDB) shall supply each of the connected panels. From DCDB / panel to driver/load feeder shall be in scope of Bidder. The exact design, rating & number of feeders of the each redundant DCDB shall be as finalized during detailed engineering and as approved by Employer. However, 25% spare feeder (min. 1 no.) with fuses for each rating shall be provided in each DCDB.		
10.00.00	CONTROL CABINETS / PANELS / DESKS		
10.01.00	The cabinets shall be IP-22 protection class. The Contractor shall ensure that the packaging density of equipment in these cabinets is not excessive and abnormal temperature rise, above the cabinet temperature during normal operation or air-conditioning failure, is prevented by careful design. This shall be demonstrated to the Employer during the factory testing of the system. The Contractor shall ensure that the temperature rise is limited to 10 deg. C above ambient and is well within the safe limits for system components even under the worst condition and specification requirements for remote I/O cabinets. Ventilation blowers shall be furnished as required by the equipment design and shall be sound proof to the maximum feasible extent. If blowers are required for satisfactory system operation, dual blowers with		
SINGRAULI STPP STAGE-III (1X500 MW) EPC PACKAGE	TECHNICAL SPECIFICATION SECTION - VI PART-B	SUB-SECTION-C-12(A) PLC BASED CONTROL SYSTEM	PAGE 13 OF 16

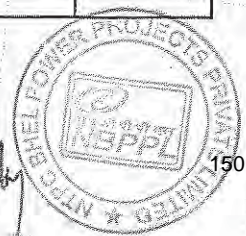

08637

CLAUSE NO.	TECHNICAL REQUIREMENTS		
	blower failure alarm shall be provided in each cabinet with proper enclosure and details shall be furnished with proposal. Suitable louvers with wire mesh shall be provided on the cabinet.		
10.01.01	The cabinets shall be designed for front access to system modules and rear access to wiring and shall be designed for bottom entry of the cables.		
10.01.02	The cabinets shall be totally enclosed, free standing type and shall be constructed with minimum 2 mm thick steel plate frame and 1.6 mm thick CRCA steel sheet or as per supplier's standard practice for similar applications, preferred height of the cabinet is 2200 mm. The cabinets shall be equipped with full height front and rear doors. The floor mounting arrangement for other cabinets shall be as required by the Employer and shall be furnished by the Contractor during detailed engineering.		
10.01.03	Cabinet doors shall be hinged and shall have turned back edges and additional braking where required ensuring rigidity. Hinges shall be of concealed type. Door latches shall be of three-point type to assure tight closing. Detachable lifting eyes or angles shall be furnished at the top of each separately shipped section and all necessary provisions shall be made to facilitate handling without damage. Front and rear doors shall be provided with locking arrangements with a master key for all cabinets. If width of a cabinet is more than 800 mm, double doors shall be provided.		
10.01.04	<p>Two spray coats of inhibitive epoxy primer-surface shall be applied to all exterior and interior surfaces. A minimum of 2 spray coats of final finish colour shall be applied to all surfaces. The final finished thickness of paint film on steel shall not be less than 65-75 micron for sheet thickness of 2 mm and 50 microns for sheet thickness of 1.6 mm. The finish colors for exterior and interior surfaces shall conform to following shades:</p> <p>(a.) Exterior:- As per RAL 9002 (End panel sides RAL 5012), to be finalised during detailed engineering.</p> <p>(b.) Interior:- Same as above.</p>		
10.01.05	<p>Paint films which show sags, checks or other imperfections shall not be acceptable.</p> <p>As an alternative, single coat of anodic dipcoat primer along with single textured powder coating with epoxy polyester meeting the thickness requirement is also acceptable.</p>		
10.01.06	Refer Subsection Basic Design Criteria, Part B, Section VI for grounding requirements.		
10.02.00	The mimic shall be configured on the OWS/CRTs and it shall be possible to control, monitor and operate the plant from the same.		
10.03.00	The technical specification covering panel fabrication details, wiring and termination details etc. shall be as described under Sub-Section INST CABLE of this specification.		
SINGRAULI STPP STAGE-III (1X600 MW) EPC PACKAGE	TECHNICAL SPECIFICATION SECTION - VI PART-B	SUB-SECTION-C-12(A) PLC BASED CONTROL SYSTEM	PAGE 14 OF 16

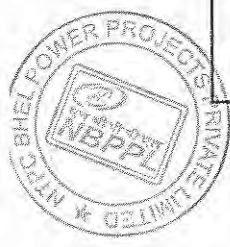

Handwritten signature/initials

08638

78888

CLAUSE NO.	TECHNICAL REQUIREMENTS			
10.04.00	CONTROL DESK			
10.04.01	Control desk shall be free standing table top type with doors at the back and shall be constructed of 3 mm thick CRCA steel plates. A 19 mm thick wooden top shall be provided on the desk to keep the TFT monitors at top and computers inside. Control desk shall consist of vertical, horizontal and base supports with their coverings for work surface, keyboard trays, mouse pads, monitor shelf and concealed cable and wire way management, perforated trays with covers in both horizontal and vertical directions. PA system hand sets, telephone sets, very few PB stations and lamps shall be mounted on the control desk on mosaic grid structure and same shall be decided during detailed engineering. ASCII Keyboard shall be capable of being pulled out through a tray.			
10.04.02	The cabling / wiring between OWS & CPU'S, power supply cables etc. shall be aesthetically routed and concealed from view.			
10.05.00	FURNITURE Chairs – Industry standard revolving chairs with wheels and with provision for adjustment of height (hydraulically/gas lift) shall be provided for the operators, unit-in-charge & other personnel in control room area. These shall be designed for sitting for long duration such that these are comfortable for the back. Chair pedestal shall be made of 5mm thick MS plate covered with poly-propylene cladding. Arm-rests in one piece shall be of poly-urethane and twin wheel castor of glass filled nylon. The exact details shall be finalized & approved by Employer during detailed engineering.			
11.00.00	ANNUNCIATION SYSTEM			
11.01.00	Only OWS / GIU based alarm system shall be provided with audio alarm facility (beep/tone generator). No facia annunciation is envisaged in the control room. Hooters are to be provided.			
11.02.00	The system shall display history of alarms in chronological order on any of the OWS / GIU. The HMIS shall have the capability to store a minimum of 500 alarms each with paging features allowing the operator to view any page. The system shall have all alarm functions and related function keys like alarm acknowledge, reset, paging, summaries etc. Other design features like set point/dead band adjustments, provision of alarm priority, manual inhibition & automatic inhibition based on predefined logic etc., shall be provided and shall be as finalised during detailed engineering. The alarm display/report format shall be as approved by the Employer.			
11.03.00	Facility of audio annunciation shall be provided in OWS / GIU upon the occurrence OWS alarms irrespective of whether alarms are displayed or not. Facility to disable the audio annunciation shall be provided.			
11.04.00	At least three levels of alarm priority shall be available which will be displayed in different colour. It shall be possible to display & print alarms of any of the three levels.			
SINGRAULI STPP STAGE-III (1X500 MW) EPC PACKAGE	TECHNICAL SPECIFICATION SECTION - VI PART-B	SUB-SECTION-C-12(A) PLC BASED CONTROL SYSTEM	PAGE 15 OF 16	

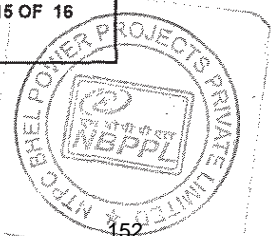

08639

CLAUSE NO.	TECHNICAL REQUIREMENTS 		
11.05.00	Alarm boxes shall be provided in each display to alert the operator about an alarm when he is viewing some other picture. No of alarm boxes shall be finalised during detailed engineering for each process area & each priority therein.		
11.06.00	The annunciator sequence shall conform to ISA sequence ISA-2A..		
12.00.00	SOFTWARE DOCUMENTATION AND SOFTWARE LISTINGS		
12.01.00	All technical manuals, reference manuals, user's guide etc., in English required for modification/editing/addition/deletion of features in the software of the PLC System shall be furnished. The Contractor shall furnish a comprehensive list of all system/application software documentation after system finalisation for Employer's review and approval.		
12.02.00	All The software listings including Source code for application software, All special - to-project data files etc. shall be submitted by the Contractor.		
13.00.00	SOFTWARE LICENCES		
	<p>The Contractor shall provide software license for all software being used in Contractor's System. The software licenses shall be provided for the project (e.g. organisation or site license) and shall not be hardware/machine-specific. That is, if any hardware/machine is upgraded or changed, the same license shall hold good and it shall not be necessary for Employer to seek a new license/renew license due to upgradation/change of hardware/machine in Contractor's System at site. All licenses shall be valid for the continuous service life of the plant.</p> <p>As a customer support, the Contractor shall periodically inform the designated officer of the Employer about the software upgrades/new releases that would be taking place after the system is commissioned so that if required, same can be procured & implemented at site.</p>		
14.00.00	For the Specification of OWS, GIU, printer and other Human Machine interface items please refer Part-B, Sub-Section-C02, DDCMIS of Technical Specification.		
15.00.00	Following C&I drawings referred in this sub-section is enclosed herewith. Drawing No.0000-151-POI-A-013 Rev-A., Configuration diagram for PLC based Offsite Control systems.		
SINGRAULI STPP STAGE-III (1X500 MW) EPC PACKAGE	TECHNICAL SPECIFICATION SECTION - VI PART-B	SUB-SECTION-C-12(A) PLC BASED CONTROL SYSTEM	PAGE 16 OF 16

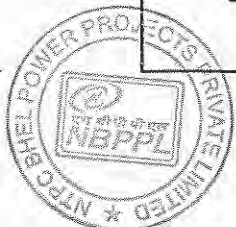

SCHEME FOR 24 VDC POWER SUPPLY SYSTEM



SET-1

SET-2

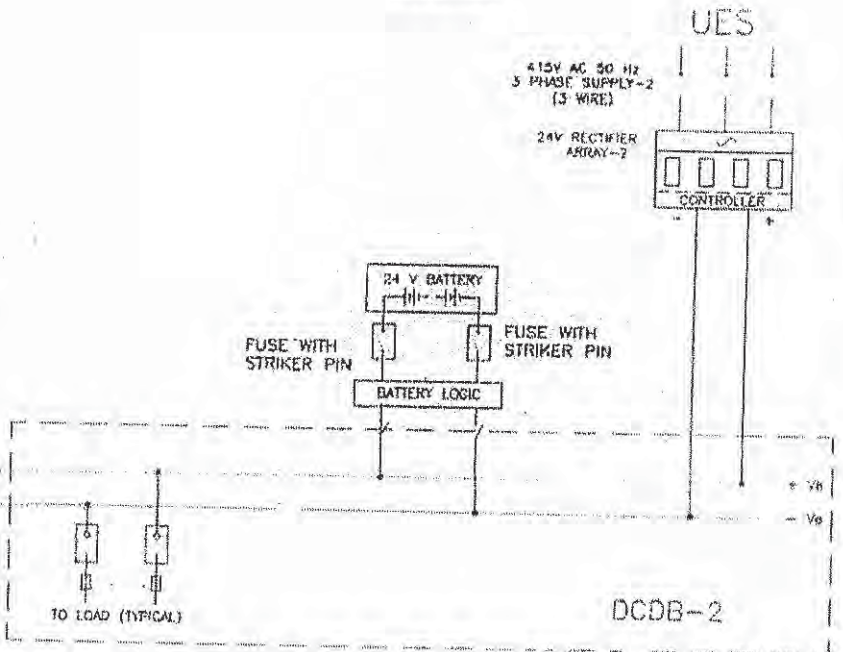
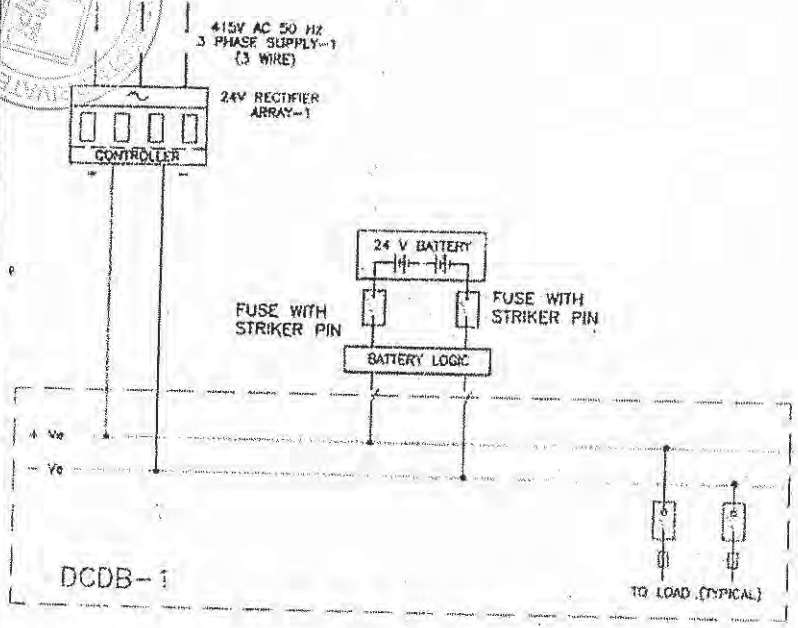

NOTES:-

- SUITABLE INTERLOCK SYSTEM SHALL BE PROVIDED IN FLOAT/HOIST CHARGING MODE.

TWO SET CONFIGURATION

- LEGEND:**
- ISOLATOR
 - MCB
 - FUSE

FOR TENDER PURPOSE ONLY

This document is the property of NATIONAL THERMAL POWER CORPORATION LTD. No part of this document will be reproduced by any means without the written permission.

NTPC Limited
(A GOVT. OF INDIA ENTERPRISE)
ENGINEERING DIVISION

PROJECT: TYPICAL THERMAL POWER PROJECT FOR DDCMIS OF OFFSITE PLANT

TITLE: SCHEME FOR 24 V DC POWER SUPPLY SYSTEM

DATE	ISSUE	BY	CHKD.	APPR.	DATE

SIZE: A3 SCALE: 1:1 DRG. NO.: 0000-999-FOI/A 019

REV. NO.	DESCRIPTION	DRAWN	DESIGN	CHKD.	DATE				
					APPR.	DATE	DATE	DATE	DATE
1	FIRST ISSUE								

00925

DCS INTERFACE FOR BIDIRECTIONAL DRIVE(WITH INTEGRAL STARTER)

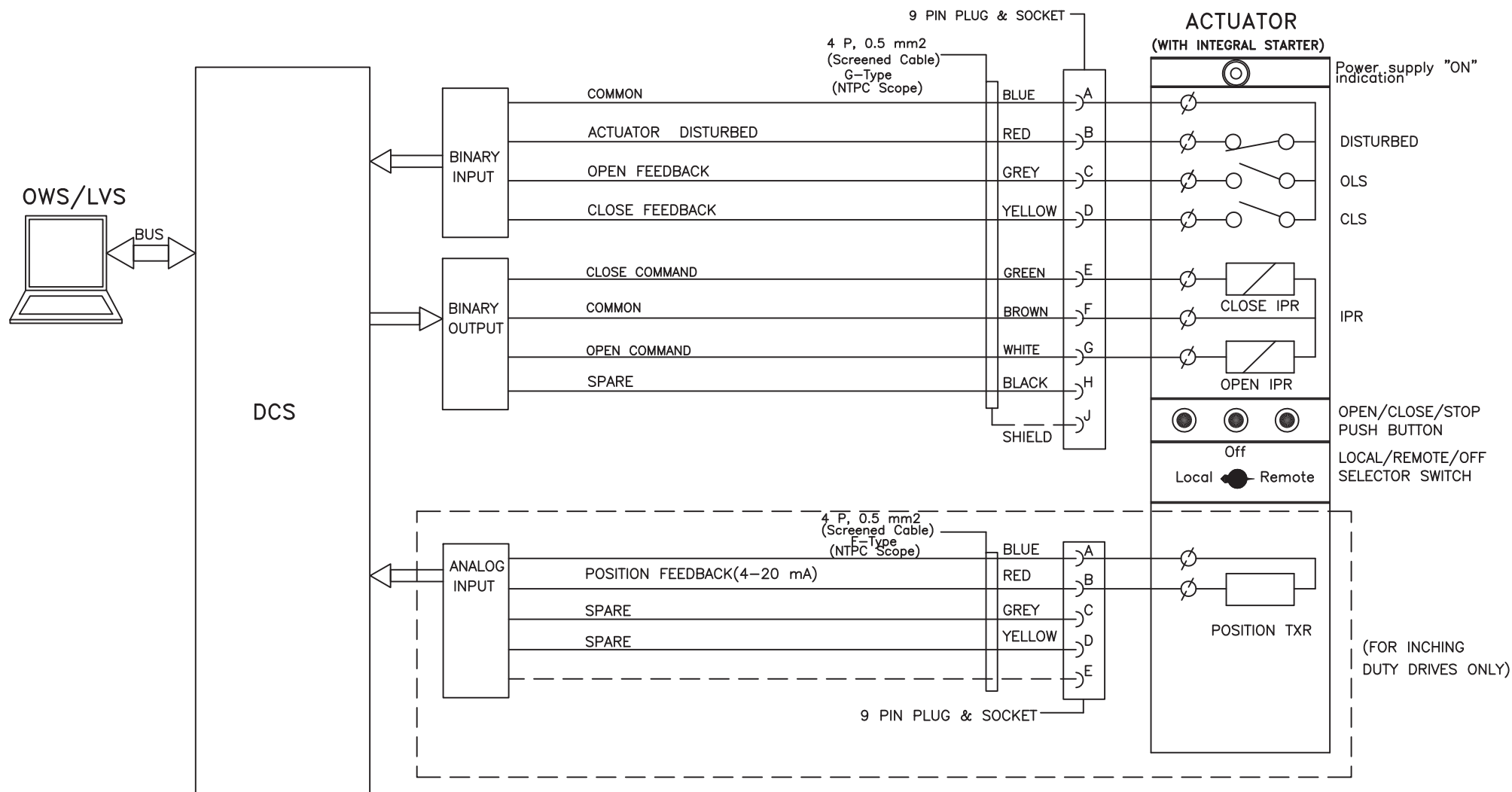

NOTE:

1. DISTURBED= Loss of Power supply (1 Phase/3 Phase),
Loss of control supply, Motor thermostat trip,
Thermal over load relay trip,
Local/Off/Remote Sel. switch in local or off mode.
Stop PB optd.



NTPC LIMITED
FEROZ GANDHI UNCHAHAR THERMAL POWER PLANT(1 X 500 MW)

TITLE
**DCS INTERFACE FOR
BIDIRECTIONAL DRIVE**

DRG.NO. **PE-DM-401-145-1002**

DATE 05.03.2014

REV.NO. 00

SHT 7 OF 13₁₅₅

DCS INTERFACE FOR UNIDIRECTIONAL LT DRIVE (CONTACTOR CONTROLLED)

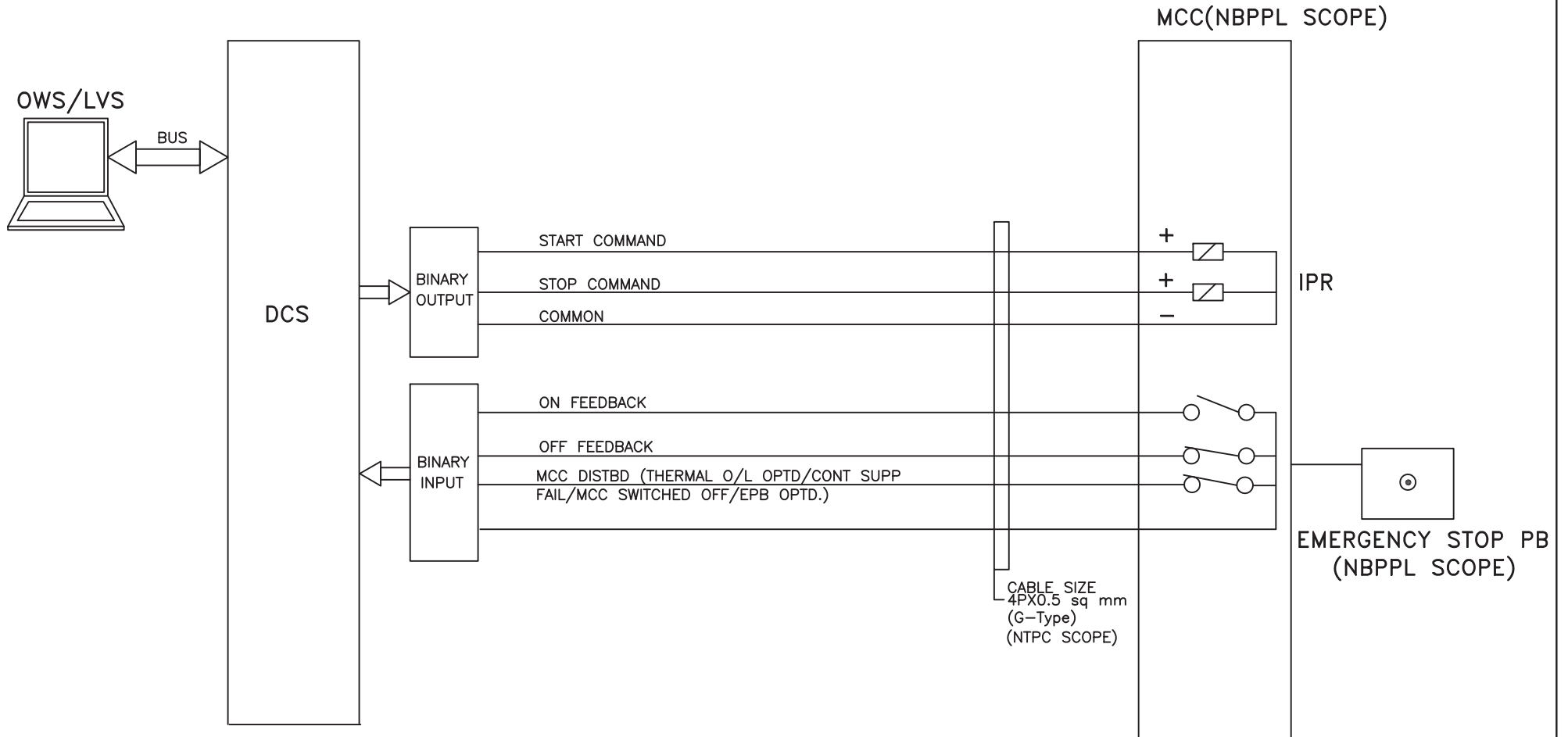

	NTPC LIMITED	DRG.NO.	PE-DM-401-145-1002	
	FEROZ GANDHI UNCHAHAR THERMAL POWER PLANT(1 X 500 MW)	DATE	05.03.2014	
	TITLE	DCS INTERFACE FOR UNIDIRECTIONAL LT DRIVE	REV.NO.	00
	SHT	8	OF	13 ₁₅₆

DCS INTERFACE FOR SOLENOID DRIVE (24V DC/240V AC)

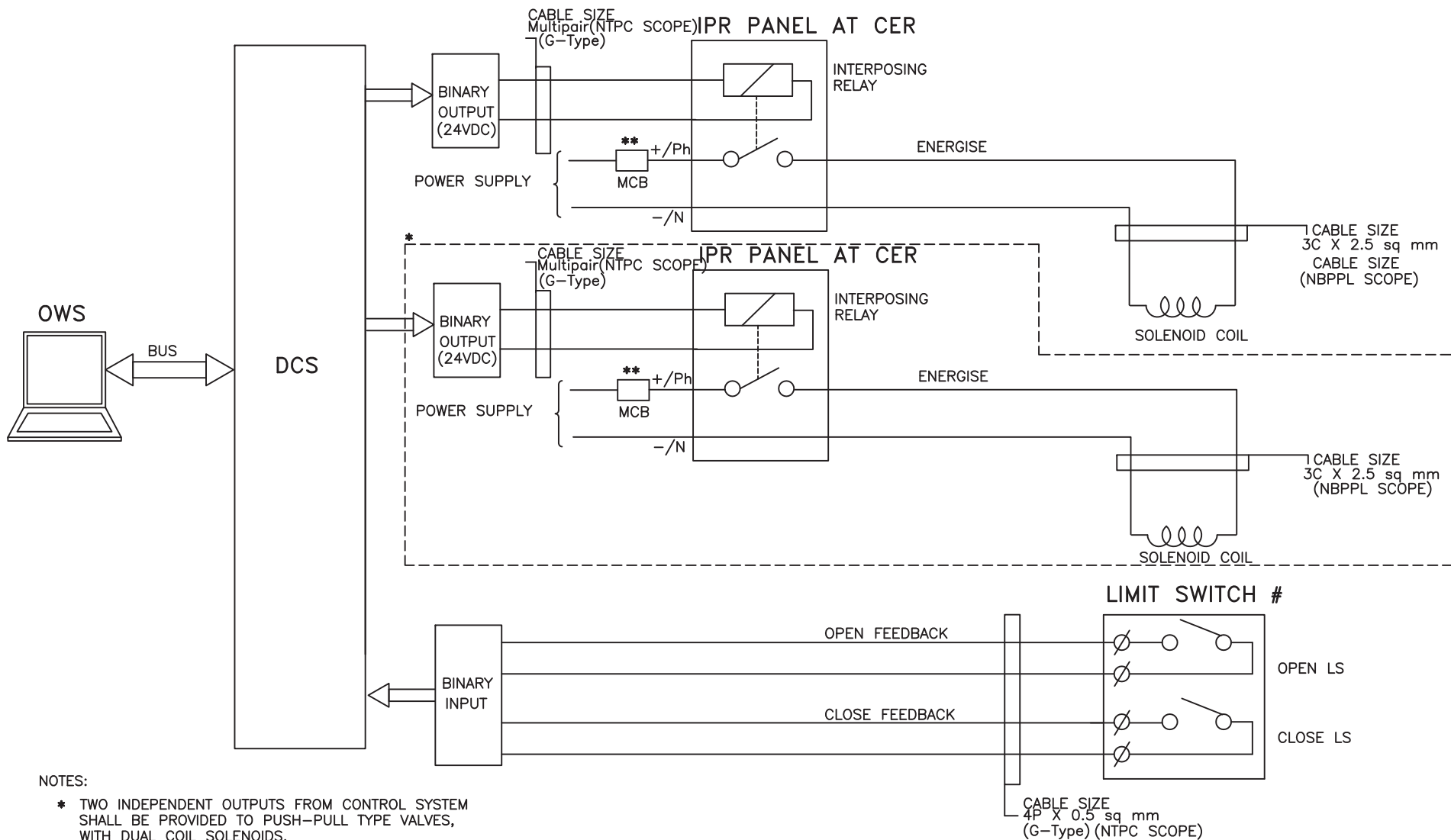

NOTES:

- * TWO INDEPENDENT OUTPUTS FROM CONTROL SYSTEM SHALL BE PROVIDED TO PUSH-PULL TYPE VALVES, WITH DUAL COIL SOLENOIDS.
- ** MCB SHALL BE PROVIDED FOR EACH SOLENOID
- # FOR ON/OFF TYPE, SOLENOID ACTUATED CONTROL VALVE.



NTPC LIMITED		DRG.NO.	PE-DM-401-145-1002
FEROZ GANDHI UNCHAHAR THERMAL POWER PLANT(1 X 500 MW)		DATE	05.03.2014
TITLE	DCS INTERFACE FOR SOLENOID DRIVE	REV.NO.	00
		SHT	9 OF 13 ₁₅₇

DCS INTERFACE FOR UNIDIRECTIONAL HT DRIVE/ LT DRIVE (BREAKER CONTROLLED)

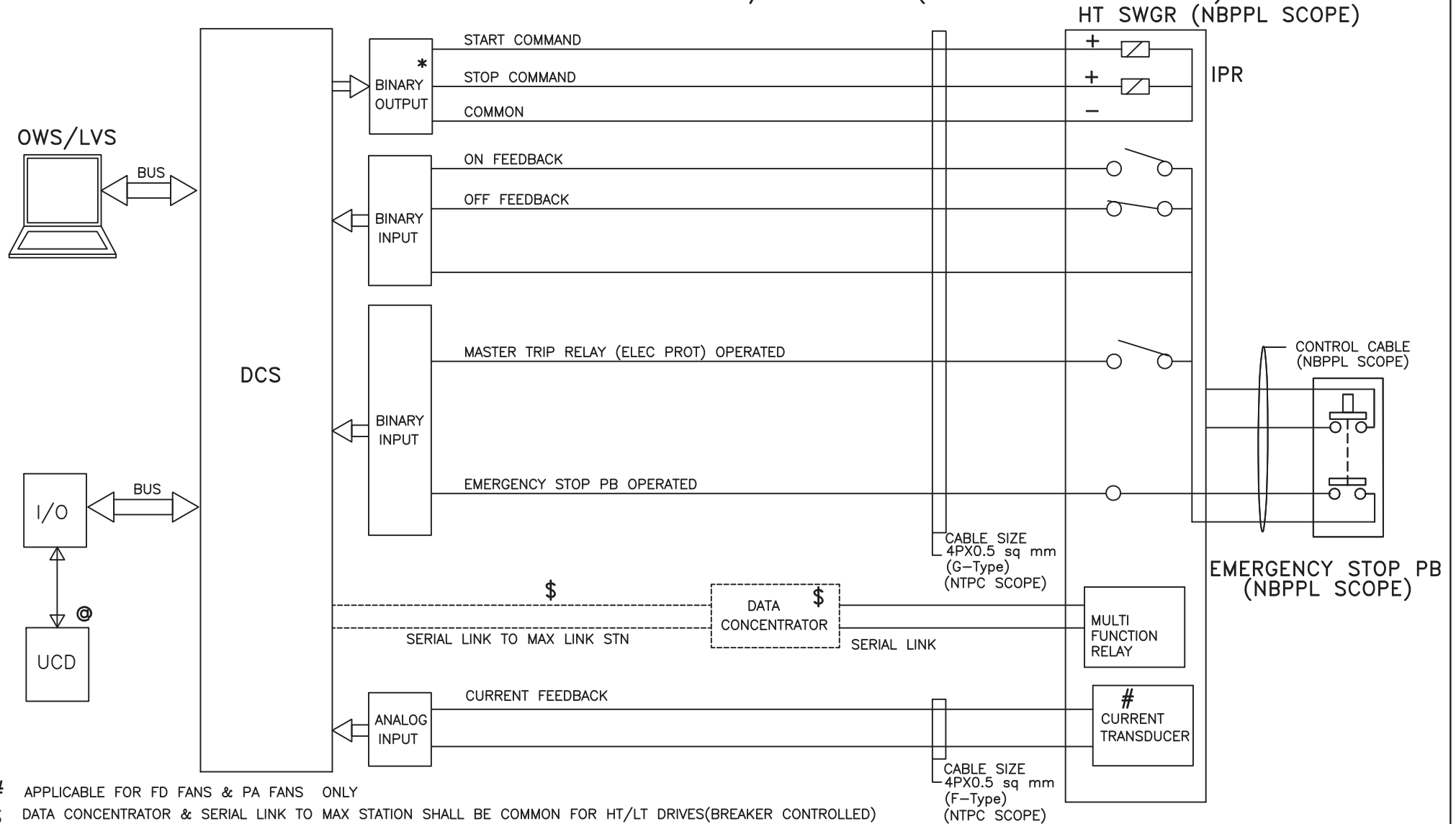

APPLICABLE FOR FD FANS & PA FANS ONLY

\$ DATA CONCENTRATOR & SERIAL LINK TO MAX STATION SHALL BE COMMON FOR HT/LT DRIVES(BREAKER CONTROLLED)

© APPLICABLE TO SELECTED DRIVES ONLY.

* REDUNDANCY SHALL BE PROVIDED AS PER CLAUSE 1.01.00, NOTE 12, CONTRACT QUANTITIES FOR DDCMIS, APPENDIX-I TO PART-A OF TECHNICAL SPECIFICATION.

NOTE: 1. EXACT NO. OF PORTS/ LINKS BETWEEN NUMERICAL RELAYS & MAX LINK STATION SHALL BE AS PER THE APPROVED SWGR & DATA CONCENTRATOR DRAWINGS.
 2. OVER LOAD ALARM, RELAY FAULT, SWGR AVAILABLE & SWGR DISTURBED SIGNALS ALONG WITH OTHER INFORMATION SHALL FLOW THROUGH SOFT LINK

	NTPC LIMITED	DRG.NO.	PE-DM-401-145-1002	
	FEROZ GANDHI UNCHAHAR THERMAL POWER PLANT(1 X 500 MW)		DATE	05.03.2014
	TITLE DCS INTERFACE FOR UNIDIRECTIONAL HT DRIVE		REV.NO.	00
			SHT	10 OF 13 ₁₅₈

DCS INTERFACE FOR CONTROL VALVE WITH SMART POSITIONER

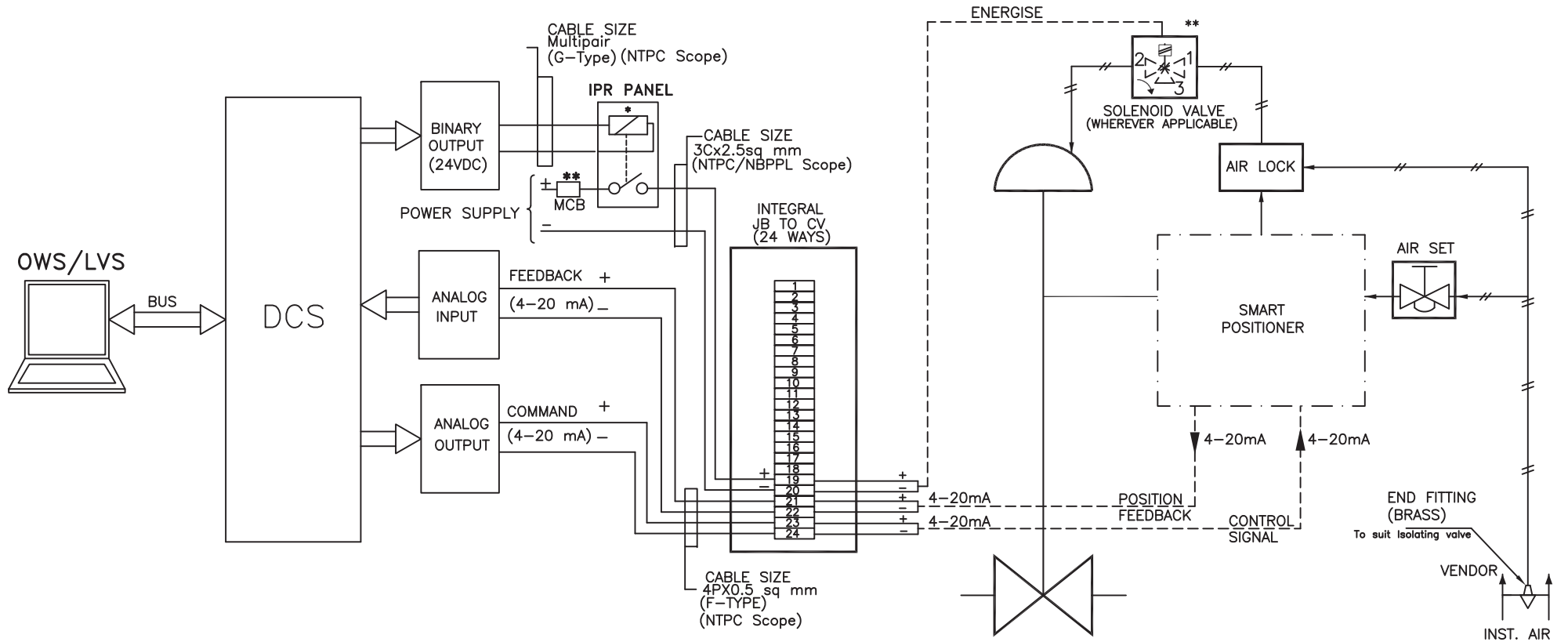

* MULTIPAIR CABLE IS TO BE USED FOR CONNECTION.

** APPLICABLE TO VALVES WHERE OPEN/CLOSE ACTION REQUIRED ON INTERLOCK CONDITION

NOTE:

1. PORT 1 & 2 SHALL BE CONNECTED IN DE-ENERGISED CONDITION.
2. PORT 2 & 3 SHALL BE CONNECTED IN ENERGISED CONDITION.





NTPC LIMITED
 FERAZ GANDHI UNCHAHAR THERMAL POWER PLANT(1 X 500 MW)

TITLE
 DCS INTERFACE FOR
 CONTROL VALVE WITH SMART POSITIONER

DRG.NO.	PE-DM-401-145-1002
DATE	05.03.2014
REV.NO.	00
SHT	11 OF 13 ₁₅₉

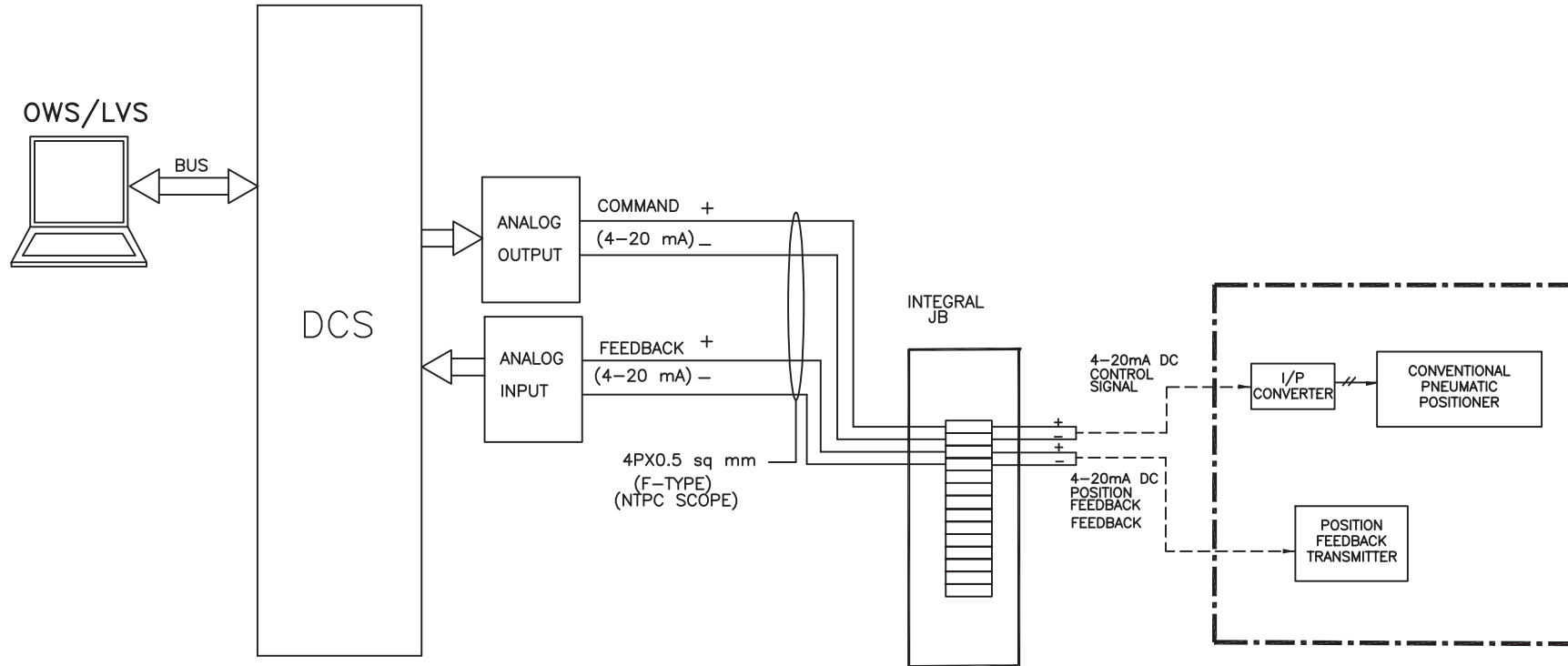
DCS INTERFACE FOR MODULATING TYPE PNEUMATIC DAMPER



	NTPC LIMITED	DRG.NO.	PE-DM-401-145-1002	
	FEROZ GANDHI UNCHAHAR THERMAL POWER PLANT(1 X 500 MW)	DATE	05.03.2014	
	TITLE	DCS INTERFACE FOR MODULATING TYPE PNEUMATIC DAMPER	REV.NO.	00
	SHT	12 OF 13	160	

DCS INTERFACE FOR VFD CONTROL DRIVE

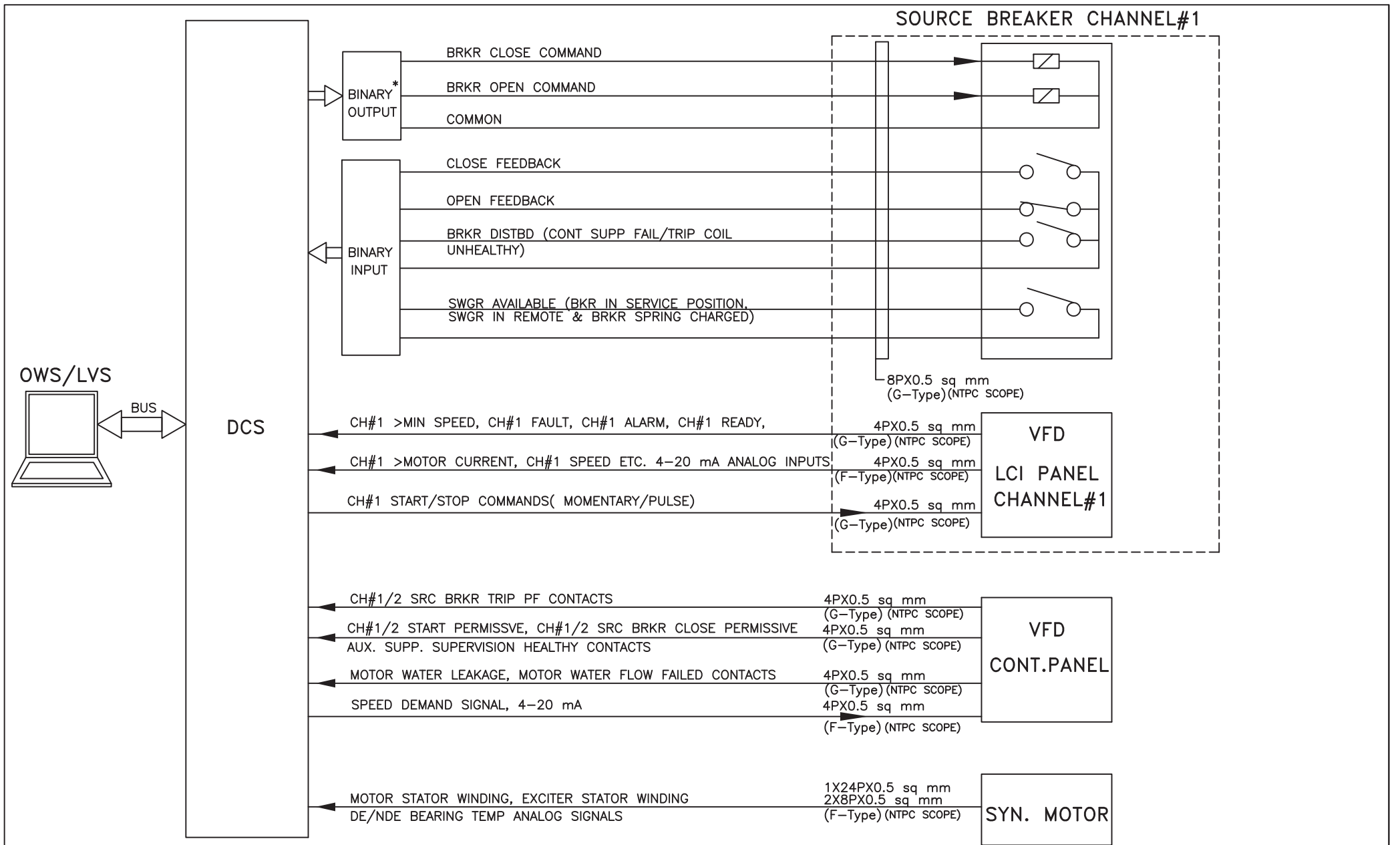

NOTES:

1. SIGNAL INTERFACE FOR CH#2 SRC BRKR AND VFD LCI PANEL SHALL BE IDENTICAL TO CH#1 AS INDICATED IN DOTTED PORTION.
- * REDUNDANCY SHALL BE PROVIDED AS PER CLAUSE 1.01.00, NOTE 12, CONTRACT QUANTITIES FOR DDCMIS, APPENDIX-I TO PART-A OF TECHNICAL SPECIFICATION.

	NTPC LIMITED	DRG.NO.	PE-DM-401-145-1002	
	FEROZ GANDHI UNCHAHAR THERMAL POWER PLANT(1 X 500 MW)	DATE	05.03.2014	
	TITLE	DCS INTERFACE FOR VFD DRIVE	REV.NO.	00
			SHT	13 OF 13, 161

CLAUSE NO.	TECHNICAL REQUIREMENTS	एनटीपीसी NTPC						
1.00.00	MEASURING INSTRUMENTS (PRIMARY AND SECONDARY)							
1.01.00	Measuring instruments/equipment and subsystems offered by the Bidder shall be from reputed experienced manufacturers of specified type and range of equipment, whose guaranteed and trouble free operation has been proven. Refer Sub-section Basic Design Criteria. Further, all instruments shall be of proven reliability, accuracy, and repeatability requiring a minimum of maintenance and shall comply with the acceptable international standards and shall be subject to Employer's approval.							
1.02.00	Every panel-mounted instrument requiring power supply shall be provided with a pair of easily replaceable glass cartridge fuses of suitable rating. Every instrument shall be provided with a grounding terminal and shall be suitably connected to the panel grounding bus.							
1.03.00	All transmitters, sensors, and switches for parameters like pressure, temperature, level, flow etc. as required for the safe and efficient operation and maintenance as well as for operator and management information (including all computation) of equipment in the system under the scope of specification shall be provided as indicated in the APPENDIX-I TO PART A OF TECHNICAL SPECIFICATIONS/ tender drawings. Estimated system parameters & instrument ranges etc. are indicated in the I & C device list. The exact value shall be provided by Employer during detailed engineering. The Contractor shall furnish all Instrumentation / Control equipment & accessories under this specification as per technical specification, ranges, makes & model as approved by the Employer during detailed engineering.							
1.04.00	The necessary root valves, impulse piping, drain cocks, gauge-zeroing cocks, valve manifolds and all the other accessories required for mounting/erection of these local instruments shall be furnished, even if not specifically asked for, on as required basis. The contacts of equipment mounted instruments, sensors, switches etc. for external connection including spare contacts shall be wired out in flexible/rigid conduits, independently to suitably located common junction boxes. The proposal shall include the necessary cables, flexible conduits, junction boxes and accessories for the above purpose. Double root valves shall be provided for all pressure tapping where the pressure exceeds 40 Kg./sq.cm.							
1.05.00	The quantity of secondary instruments etc. to be provided by Contractor is listed in Appendix-I to Part A of Technical Specifications.							
2.00.00	<p>SPECIFICATION FOR ELECTRONIC TRANSMITTER FOR PRESSURE, D.P., FLOW AND LEVEL</p> <p>ELECTRONIC TRANSMITTERS</p> <table border="1"> <thead> <tr> <th data-bbox="389 1666 485 1697">Sl.No.</th> <th data-bbox="501 1666 724 1697">Features</th> <th data-bbox="740 1666 1155 1697">Essential/Minimum Requirements</th> </tr> </thead> <tbody> <tr> <td data-bbox="389 1724 405 1756">1.</td> <td data-bbox="501 1724 628 1787">Type of Transmitter</td> <td data-bbox="740 1724 1299 1787">Microprocessor based 2 wire type, Hart protocol compatible.</td> </tr> </tbody> </table>		Sl.No.	Features	Essential/Minimum Requirements	1.	Type of Transmitter	Microprocessor based 2 wire type, Hart protocol compatible.
Sl.No.	Features	Essential/Minimum Requirements						
1.	Type of Transmitter	Microprocessor based 2 wire type, Hart protocol compatible.						
SINGRAULI STPP STAGE-III (1X500 MW) EPC PACKAGE	TECHNICAL SPECIFICATION SECTION - VI PART-B	SUB-SECTION-C-03(A) MEASURING INSTRUMENTS (PRIMARY & SECONDARY)	PAGE 1 OF 45					

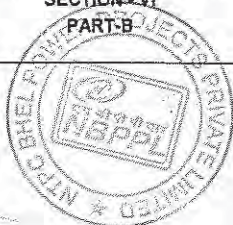

08470

CLAUSE NO.	TECHNICAL REQUIREMENTS			
	2.	Accuracy	± 0.1% of calibrated span (minimum) (upto turn down ratio of 10:1)	
	3.	Output signal range	4-20 mA DC (Analog) along with superimposed digital signal (based on HART protocol)	
	4.	Turn down ratio	10:1 for vacuum/very low pressure applications. 5:1 for very high pressure application. 30:1 for other applications.	
	5.	Stability	± 0.1% of calibrated span for six months for Ranges up to and including 70 Kg/cm ² . ± 0.25% of calibrated span for six months for Ranges more than 70 Kg/cm ² (g).	
	6.	Zero and span drift	+/- 0.015% per deg.C at max span. +/-0.11% per deg.C at min. Span.	
	7.	Load impedance	500 ohm (min.)	
	8.	Housing	Weather proof as per IP-55 with durable corrosion resistant coating.	
	9.	Over Pressure	150% of max. Operating pressure	
	10.	Connection (Electrical)	Plug and socket type	
	11.	Process connection	1/2 inch NPT (F)	
	12.	Span and Zero	Continuous, tamper proof, Remote as well as adjustability manual from instrument with zero suppression and elevation facility.	
	13.	Accessories	-Diaphragm seal, pulsation dampeners, syphon etc. as required by service and operating condition. -2 valve manifold for absolute & Gauge pressure transmitters, 3-valve manifold for vacuum pressure transmitters & where DP transmitters are being used for pressure measurement and 5 valve manifold for DP/Level/Flow applicable. -For hazardous area, explosions proof enclosure as described in NEC article 500.	
SINGRAULI STPP STAGE-III (1X500 MW) EPC PACKAGE	TECHNICAL SPECIFICATION SECTION - VI PART-B	SUB-SECTION-C-03(A) MEASURING INSTRUMENTS (PRIMARY & SECONDARY)	PAGE 2 OF 45	

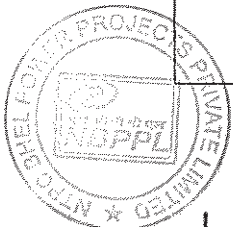

08471

CLAUSE NO.	TECHNICAL REQUIREMENTS																				
2.01.00	14. Diagnostics 15. Power supply 16. Adjustment/calibration/maintenance	Self Indicating feature 24V DC \pm 10%. From hand held calibrator/centralized PC based system (as applicable).																			
	<p>Notes</p> <p>For air/flue gas applications, DP type transmitters shall be provided for pressure measurement.</p> <p>LVDT type is not acceptable.</p> <p>Where the process fluids are corrosive, viscous, solid bearing or slurry type, diaphragm seals shall be provided. Parts below the diaphragm shall be removable for cleaning. The entire volume above the diaphragm shall be completely filled with an inert liquid suitable for the application.</p>																				
<p>GUIDED WAVE RADAR TYPE LEVEL TRANSMITTER</p>																					
<p>Guided wave radar type level transmitters shall be provided for level measurements of the vessel under vacuum or low pressure applications.</p>																					
<table border="0"> <tr> <td>Type</td> <td>Guided wave Radar</td> </tr> <tr> <td>Principle</td> <td>TDR (Time domain reflectometry)</td> </tr> <tr> <td>Probe Type& Material</td> <td>Coaxial, SS316/316L. If required, probe shall be suitable for overflow prevention.</td> </tr> <tr> <td>Signal o/p</td> <td>4-20mA with HART signal suitable for overflow prevention.</td> </tr> <tr> <td>Display</td> <td>Integral</td> </tr> <tr> <td>Power supply</td> <td>24 VDC</td> </tr> <tr> <td>Accuracy</td> <td>5mm</td> </tr> <tr> <td>Electromagnetic compatibility</td> <td>Shall meet EN 61326-1 (1997) and AmdtA1, class A equipment/EN 50081-2 & EN 5008 1-2 & EN 50082-2</td> </tr> <tr> <td>Mounting</td> <td>External cage mounting</td> </tr> </table>				Type	Guided wave Radar	Principle	TDR (Time domain reflectometry)	Probe Type& Material	Coaxial, SS316/316L. If required, probe shall be suitable for overflow prevention.	Signal o/p	4-20mA with HART signal suitable for overflow prevention.	Display	Integral	Power supply	24 VDC	Accuracy	5mm	Electromagnetic compatibility	Shall meet EN 61326-1 (1997) and AmdtA1, class A equipment/EN 50081-2 & EN 5008 1-2 & EN 50082-2	Mounting	External cage mounting
Type	Guided wave Radar																				
Principle	TDR (Time domain reflectometry)																				
Probe Type& Material	Coaxial, SS316/316L. If required, probe shall be suitable for overflow prevention.																				
Signal o/p	4-20mA with HART signal suitable for overflow prevention.																				
Display	Integral																				
Power supply	24 VDC																				
Accuracy	5mm																				
Electromagnetic compatibility	Shall meet EN 61326-1 (1997) and AmdtA1, class A equipment/EN 50081-2 & EN 5008 1-2 & EN 50082-2																				
Mounting	External cage mounting																				
<p>The transmitters shall be provided with IP-55 protection class with durable corrosion resistant coating.</p>																					
<p>SINGRAULI STPP STAGE-III (1X500 MW) EPC PACKAGE</p>	<p>TECHNICAL SPECIFICATION SECTION - VI PART-B</p>	<p>SUB-SECTION-C-03(A) MEASURING INSTRUMENTS (PRIMARY & SECONDARY)</p>	<p>PAGE 3 OF 45</p>																		

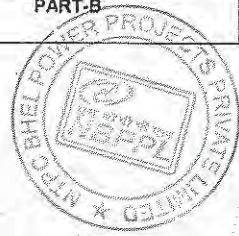

08472

CLAUSE NO.	TECHNICAL REQUIREMENTS																																																														
	<p>The transmitters shall be able to provide digital signals super imposed on 4-20 mA signal as per HART protocol.</p> <p>Ultrasonic Type level Transmitter</p> <table border="1" data-bbox="399 448 1348 1691"> <thead> <tr> <th>Sl.No.</th> <th>Features</th> <th>Essential/Minimum requirement</th> </tr> </thead> <tbody> <tr> <td>1.</td> <td>Type of Transmitter</td> <td>Non contact Microprocessor based 2 wire type, HART protocol compatible Ultrasonic transmitter</td> </tr> <tr> <td>2.</td> <td>Output signal</td> <td>Galvanically isolated 4-20mA DC (Analog) along with superimposed digital signal (based on HART protocol)</td> </tr> <tr> <td>3.</td> <td>Sensor Accuracy</td> <td>+/- 0.5% of calibrated span.</td> </tr> <tr> <td>4.</td> <td>Sensor Repeatability</td> <td>3mm or better</td> </tr> <tr> <td>5.</td> <td>Power supply</td> <td>24 V DC +/-10%</td> </tr> <tr> <td>6.</td> <td>Temperature compensation</td> <td>To be provided within transducer</td> </tr> <tr> <td>7.</td> <td>Configuration</td> <td>Sensor unit and Electronic units are to be separate. It shall be possible to mount the Electronic unit at a remote accessible location from the transducer. All cables and weather proof fittings to interconnect transducer to electronic unit shall be provided by Bidder.</td> </tr> <tr> <td>8.</td> <td>Housing</td> <td>Weather proof as per IP-55 with durable corrosion resistant coating.</td> </tr> <tr> <td>9.</td> <td>Calibration</td> <td>Through HART Communicator.</td> </tr> <tr> <td>10.</td> <td>Zero and Span adjustment</td> <td>Continuous, tamper proof, remote as well as manual adjustability from instrument. It shall be possible to calibrate the instrument without any level in the tank/sump etc.</td> </tr> <tr> <td>11.</td> <td>Sensor Material</td> <td>Corrosion resistant material to suit individual application requirement.</td> </tr> <tr> <td>12.</td> <td>False signal tolerance</td> <td>Transmitter shall be capable of ignoring false echoes from internal tank/sumps obstructions such as pipes, heating coils or agitator blades. Also transmitter shall have adjustable damping circuitry</td> </tr> <tr> <td>13.</td> <td>Range</td> <td>Range of transmitter shall be capable of covering the complete level span of tank taking care of blocking distance, frequency attenuation due to surface, obstructions, vapors etc.</td> </tr> <tr> <td>14.</td> <td>Display</td> <td>Minimum 4 character LCD display with integral keypad, access protected by user code</td> </tr> <tr> <td>15.</td> <td>Diagnostics</td> <td>Loss of echo alarm etc.</td> </tr> <tr> <td>16.</td> <td>Load Impedance</td> <td>500 ohms minimum</td> </tr> <tr> <td>17.</td> <td>Electrical Connection</td> <td>Plug and socket</td> </tr> <tr> <td>18.</td> <td>Accessories</td> <td>All weather canopy for protection from direct sunlight and direct rain. All mounting hardware and accessories required for erection and commissioning mounting fittings material shall be Ss 316. For hazardous areas, explosion proof enclosure as described in NEC article 500</td> </tr> <tr> <td colspan="2">Note:</td> <td>Contractor can also provide Radar type transmitter in place of ultrasonic transmitters subject to approval by Employer during detailed Engineer.</td> </tr> </tbody> </table>			Sl.No.	Features	Essential/Minimum requirement	1.	Type of Transmitter	Non contact Microprocessor based 2 wire type, HART protocol compatible Ultrasonic transmitter	2.	Output signal	Galvanically isolated 4-20mA DC (Analog) along with superimposed digital signal (based on HART protocol)	3.	Sensor Accuracy	+/- 0.5% of calibrated span.	4.	Sensor Repeatability	3mm or better	5.	Power supply	24 V DC +/-10%	6.	Temperature compensation	To be provided within transducer	7.	Configuration	Sensor unit and Electronic units are to be separate. It shall be possible to mount the Electronic unit at a remote accessible location from the transducer. All cables and weather proof fittings to interconnect transducer to electronic unit shall be provided by Bidder.	8.	Housing	Weather proof as per IP-55 with durable corrosion resistant coating.	9.	Calibration	Through HART Communicator.	10.	Zero and Span adjustment	Continuous, tamper proof, remote as well as manual adjustability from instrument. It shall be possible to calibrate the instrument without any level in the tank/sump etc.	11.	Sensor Material	Corrosion resistant material to suit individual application requirement.	12.	False signal tolerance	Transmitter shall be capable of ignoring false echoes from internal tank/sumps obstructions such as pipes, heating coils or agitator blades. Also transmitter shall have adjustable damping circuitry	13.	Range	Range of transmitter shall be capable of covering the complete level span of tank taking care of blocking distance, frequency attenuation due to surface, obstructions, vapors etc.	14.	Display	Minimum 4 character LCD display with integral keypad, access protected by user code	15.	Diagnostics	Loss of echo alarm etc.	16.	Load Impedance	500 ohms minimum	17.	Electrical Connection	Plug and socket	18.	Accessories	All weather canopy for protection from direct sunlight and direct rain. All mounting hardware and accessories required for erection and commissioning mounting fittings material shall be Ss 316. For hazardous areas, explosion proof enclosure as described in NEC article 500	Note:		Contractor can also provide Radar type transmitter in place of ultrasonic transmitters subject to approval by Employer during detailed Engineer.
Sl.No.	Features	Essential/Minimum requirement																																																													
1.	Type of Transmitter	Non contact Microprocessor based 2 wire type, HART protocol compatible Ultrasonic transmitter																																																													
2.	Output signal	Galvanically isolated 4-20mA DC (Analog) along with superimposed digital signal (based on HART protocol)																																																													
3.	Sensor Accuracy	+/- 0.5% of calibrated span.																																																													
4.	Sensor Repeatability	3mm or better																																																													
5.	Power supply	24 V DC +/-10%																																																													
6.	Temperature compensation	To be provided within transducer																																																													
7.	Configuration	Sensor unit and Electronic units are to be separate. It shall be possible to mount the Electronic unit at a remote accessible location from the transducer. All cables and weather proof fittings to interconnect transducer to electronic unit shall be provided by Bidder.																																																													
8.	Housing	Weather proof as per IP-55 with durable corrosion resistant coating.																																																													
9.	Calibration	Through HART Communicator.																																																													
10.	Zero and Span adjustment	Continuous, tamper proof, remote as well as manual adjustability from instrument. It shall be possible to calibrate the instrument without any level in the tank/sump etc.																																																													
11.	Sensor Material	Corrosion resistant material to suit individual application requirement.																																																													
12.	False signal tolerance	Transmitter shall be capable of ignoring false echoes from internal tank/sumps obstructions such as pipes, heating coils or agitator blades. Also transmitter shall have adjustable damping circuitry																																																													
13.	Range	Range of transmitter shall be capable of covering the complete level span of tank taking care of blocking distance, frequency attenuation due to surface, obstructions, vapors etc.																																																													
14.	Display	Minimum 4 character LCD display with integral keypad, access protected by user code																																																													
15.	Diagnostics	Loss of echo alarm etc.																																																													
16.	Load Impedance	500 ohms minimum																																																													
17.	Electrical Connection	Plug and socket																																																													
18.	Accessories	All weather canopy for protection from direct sunlight and direct rain. All mounting hardware and accessories required for erection and commissioning mounting fittings material shall be Ss 316. For hazardous areas, explosion proof enclosure as described in NEC article 500																																																													
Note:		Contractor can also provide Radar type transmitter in place of ultrasonic transmitters subject to approval by Employer during detailed Engineer.																																																													
<p>SINGRAULI STPP STAGE-III (1X500 MW) EPC PACKAGE</p>	<p>TECHNICAL SPECIFICATION SECTION - VI PART-B</p>	<p>SUB-SECTION-C-03(A) MEASURING INSTRUMENTS (PRIMARY & SECONDARY)</p>	<p>PAGE 4 OF 45</p>																																																												

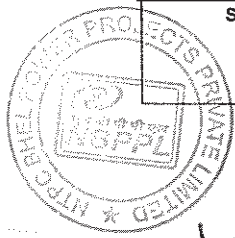

08473

S. NO.	TECHNICAL REQUIREMENTS	एनटीपीसी NTPC																											
2.00.00	<p>HART Hand Held calibrator</p> <p>Hand held calibrator shall be provided for adjustment/calibration/maintenance of the HART compatible transmitters. The hand held calibrator shall be suitable for all types of transmitters supplied in the package. If one type of hand held type calibrator is not suitable for communicating with all types of transmitters then separate hand held calibrator will be provided.</p>																												
3.00.00	<p>TEMPERATURE ELEMENTS AND ACCESSORIES</p>																												
3.00.00	<p>Thermocouple</p>																												
	<table border="1"> <thead> <tr> <th data-bbox="391 705 470 772">Sr. No.</th> <th data-bbox="502 705 837 772">Features</th> <th data-bbox="869 705 1340 772">Essential/Minimum Requirements</th> </tr> </thead> <tbody> <tr> <td data-bbox="391 795 470 840">1</td> <td data-bbox="502 795 837 840">Type of Thermocouple.</td> <td data-bbox="869 795 1340 929">: 16 AWG wire of Chromel-Alumel (Type K) or 24 AWG wire Pt-Rhodium Pt (Type R) depending on operating temperature Range (ungrounded type).</td> </tr> <tr> <td data-bbox="391 952 470 996">2</td> <td data-bbox="502 952 837 996">No. of element</td> <td data-bbox="869 952 1340 996">: Duplex</td> </tr> <tr> <td data-bbox="391 1008 470 1052">3</td> <td data-bbox="502 1008 837 1052">Housing/Head</td> <td data-bbox="869 1008 1340 1198">: IP-65/Diecast Aluminium. Head of TE to be provided with sufficient space and arrangement to mount head mounted temperature transmitter (as applicable). Plug in connectors are to be provided for external signal cable connection.</td> </tr> <tr> <td data-bbox="391 1220 470 1265">4</td> <td data-bbox="502 1220 837 1265">Sheathing of Thermocouple</td> <td data-bbox="869 1220 1340 1288">: Swaged type magnesium oxide insulation.</td> </tr> <tr> <td data-bbox="391 1310 470 1355">5</td> <td data-bbox="502 1310 837 1355">Calibration and accuracy</td> <td data-bbox="869 1310 1340 1377">: As per IEC-751/ANSI-C-96.1(special class)for T/C.</td> </tr> <tr> <td data-bbox="391 1388 470 1433">6</td> <td data-bbox="502 1388 837 1433">Characteristic</td> <td data-bbox="869 1388 1340 1456">: Linear with respect to temp, within $\pm 1/2$ percent of top range value.</td> </tr> <tr> <td data-bbox="391 1478 470 1523">7</td> <td data-bbox="502 1478 837 1523">Accessories</td> <td data-bbox="869 1478 1340 1579">: Thermo well (as specified below) and shall be spring loaded for positive contacts with the well.</td> </tr> <tr> <td data-bbox="391 1601 470 1646">8</td> <td data-bbox="502 1601 837 1646">Standard</td> <td data-bbox="869 1601 1340 1668">: ANSI C 96.1 for Thermocouple and ASME PTC-19.3 for Thermo-well.</td> </tr> </tbody> </table>	Sr. No.	Features	Essential/Minimum Requirements	1	Type of Thermocouple.	: 16 AWG wire of Chromel-Alumel (Type K) or 24 AWG wire Pt-Rhodium Pt (Type R) depending on operating temperature Range (ungrounded type).	2	No. of element	: Duplex	3	Housing/Head	: IP-65/Diecast Aluminium. Head of TE to be provided with sufficient space and arrangement to mount head mounted temperature transmitter (as applicable). Plug in connectors are to be provided for external signal cable connection.	4	Sheathing of Thermocouple	: Swaged type magnesium oxide insulation.	5	Calibration and accuracy	: As per IEC-751/ANSI-C-96.1(special class)for T/C.	6	Characteristic	: Linear with respect to temp, within $\pm 1/2$ percent of top range value.	7	Accessories	: Thermo well (as specified below) and shall be spring loaded for positive contacts with the well.	8	Standard	: ANSI C 96.1 for Thermocouple and ASME PTC-19.3 for Thermo-well.	
Sr. No.	Features	Essential/Minimum Requirements																											
1	Type of Thermocouple.	: 16 AWG wire of Chromel-Alumel (Type K) or 24 AWG wire Pt-Rhodium Pt (Type R) depending on operating temperature Range (ungrounded type).																											
2	No. of element	: Duplex																											
3	Housing/Head	: IP-65/Diecast Aluminium. Head of TE to be provided with sufficient space and arrangement to mount head mounted temperature transmitter (as applicable). Plug in connectors are to be provided for external signal cable connection.																											
4	Sheathing of Thermocouple	: Swaged type magnesium oxide insulation.																											
5	Calibration and accuracy	: As per IEC-751/ANSI-C-96.1(special class)for T/C.																											
6	Characteristic	: Linear with respect to temp, within $\pm 1/2$ percent of top range value.																											
7	Accessories	: Thermo well (as specified below) and shall be spring loaded for positive contacts with the well.																											
8	Standard	: ANSI C 96.1 for Thermocouple and ASME PTC-19.3 for Thermo-well.																											
<p>SINGRAULI STPP STAGE-III (1X500 MW) EPC PACKAGE</p>	<p>TECHNICAL SPECIFICATION SECTION - VI PART-B</p>	<p>SUB-SECTION-C-03(A) MEASURING INSTRUMENTS (PRIMARY & SECONDARY)</p>	<p>PAGE 5 OF 45</p>																										

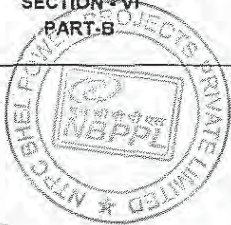

08474

CLAUSE NO.	TECHNICAL REQUIREMENTS		
3.02.00	Resistance Temperature Detector (RTD)		
	Sr. No. Features	Essential/Minimum Requirements	
	1 Type of RTD.	: Four wire, Pt-100 (100 Ohms resistance at zero degree Centigrade).	
	2 No. of element	: Duplex	
	3 Housing/Head	: IP-55/Diecast Aluminium. Head of TE to be provided with sufficient magnesium to mount head mounted temperature transmitter (as applicable). Plug in connectors are to be provided for external signal cable connection.	
	4 Sheathing of RTD	: Metal sheathed, ceramic packed	
	5 Calibration and accuracy	: As per DIN-43760 Class-A for RTD	
	6 Characteristic	: Linear with respect to temp, within $\pm 1/2$ percent of top range value.	
	7 Accessories	: Thermo well (as specified below) and shall be spring loaded for positive contacts with the well.	
	8 Standard	: DIN-43760 for RTD and ASME PTC-19.3 for Thermo-well.	
3.03.00	Metal Temperature Thermocouples		
	Measuring Medium	Metal Temperature	
	Material of Thermocouple.	Chromel Alumel Type K	
	Type of Thermocouple	Duplex with separate hot junctions, ungrounded	
	Insulation	Mineral Insulation Magnesium Oxide.	
	Thermocouple wire gauge	16 AWG	
	Protective sheath	SS 321	
	Protective sheath dia	8 mm O.D	
SINGRAULI STPP STAGE-III (1X500 MW) EPC PACKAGE	TECHNICAL SPECIFICATION SECTION - VI PART-B	SUB-SECTION-C-03(A) MEASURING INSTRUMENTS (PRIMARY & SECONDARY)	PAGE 6 OF 45

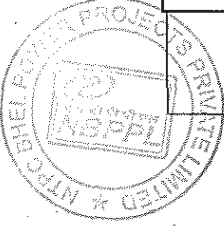

109

08475

CLAUSE NO.	TECHNICAL REQUIREMENTS		एनटीपीसी NTPC
3.04.00	Characteristics of Thermocouple	Special limits of error as in ANSI thermocouple MC 96.01.1975	
	Mounting accessories	1/2" BSP SS sliding end connector, weld pad, clamps of heat resistant steel SS310.	
	Cold end sealing	SS pot weal with colour coded PTFE headed sleeve Insulated flexible tails. Sealing compound- Epoxy resin.	
	Minimum bending radius	30 mm	
	Length of T/C	30 Mtr. (minimum)	
	<p>TEMPERATURE TRANSMITTER</p> <p>Following types of 2-wire temperature transmitter (directly powered from 4-20mA input cards of DDCMIS) shall be provided. The temperature transmitter shall be fully compatible with thermocouples and RTDs being provided by the contractor as well as Employer. Temperature compensation of the thermocouples shall be performed in the temperature transmitter itself.</p> <p>a. Single Input Head mounted Temperature Transmitter</p> <p>These shall be suitable for mounting in the head of temperature element itself. The protection class of head of thermo well along with its plug-in connector shall be min. IP65.</p> <p>b. Single Input DIN-rail mounted Temperature Transmitter</p> <p>These shall be suitable for mounting on DIN-rails in JB's. The specifications of the JB's shall be same as indicated in Subsection INST CABLE with additional DIN-rails and IP 65 Protection class . This temperature transmitter shall be the ones which are especially designed for DIN-rail mounting with IP 20 protection class. These shall have terminals for input/output provided on front side when mounted on DIN-rail. Head mounted temperature transmitter with clamps to make it suitable for DIN-rail mounting shall not be acceptable under this category.</p> <p>c. Dual-input Temperature Transmitter With Indicator:</p> <p>These shall be suitable for mounting on pipes/ support. Indicator shall be provided with these transmitters. These transmitters shall have bump less change over facility to second sensor in case first sensor fails .This change-over is to be alarmed. Protection class shall be IP65 minimum.</p> <p><i>The exact applications for which this type of transmitter is to be provided shall be finalized during detailed engineering. However, the quantity shall be as per Appendix-I to Part-A.</i></p>		
SINGRAULI STPP STAGE-III (1X500 MW) EPC PACKAGE	TECHNICAL SPECIFICATION SECTION - VI PART-B	SUB-SECTION-C-03(A) MEASURING INSTRUMENTS (PRIMARY & SECONDARY)	PAGE 7 OF 45

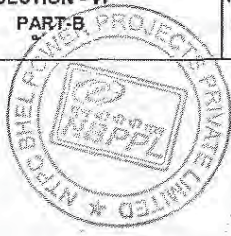

08476

CLAUSE NO.	TECHNICAL REQUIREMENTS			एन डी पी सी NTPC
	<p>d. Common requirements for each of the above type of temperature transmitters.</p> <p>Output : 2-wire (power supply from input card of Control System) with 4-20mA output with superimposed HART protocol signal.</p> <p>Input : Same transmitter shall be capable to handle Pt-100 RTD , Thermocouples –K&R types (input type to be selectable at site through HART terminal)</p> <p>Isolation : min. 500 V AC</p> <p>EMC compatibility : as per EN 61326</p> <p>Operating ambient temperature : 0 to 85 deg C (without indicator) 0 to 70 deg C (with indicator)</p> <p>Power supply : compatible with input module of Control System</p> <p>Accessories : Mounting arrangements including clamps etc.</p> <p>Composite Accuracy (a) For head mounted and DIN-rail mounted types: (Refer note 2)</p> <p>RTD = <math>\leq 0.4\%</math> of 0-250 deg C span T/C-K type = <math>\leq 0.4\%</math> of 0-600 deg C span T/C-R type = <math>\leq 0.4\%</math> of 0-1000 deg C span CJC accuracy (for thermocouples) shall be = <math>\leq 1</math> deg C</p> <p>(b) For dual-input type: RTD = <math>\leq 0.25\%</math> of 0-250 deg C span T/C-K type = <math>\leq 0.2\%</math> of 0-600 deg C span CJC accuracy (for thermocouples) shall be = <math>\leq 1</math> deg C</p> <p>e. Field bus compatible temperature transmitters</p> <p><i>Temperature transmitters of this category shall be field mounting type & shall be capable of withstanding operating ambient temperature upto 85 deg C. These modules shall be connected to DDCMIS through field bus such as Profibus, Foundation Field bus etc directly from the transmitter. Maximum Number of inputs per such temperature transmitter shall be eight. These shall be mounted in cabinets in non-AC areas.</i></p>			
SINGRAULI STPP STAGE-III (1X500 MW) EPC PACKAGE	TECHNICAL SPECIFICATION SECTION - VI PART-B	SUB-SECTION-C-03(A) MEASURING INSTRUMENTS (PRIMARY & SECONDARY)	PAGE 8 OF 45	

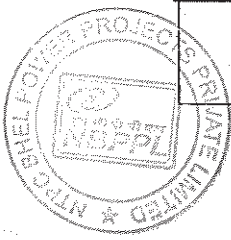

08477

CLAUSE NO.	TECHNICAL REQUIREMENTS														
	<div style="text-align: right; border: 1px solid black; padding: 2px; width: fit-content; margin: 0 auto;"> एनटीपीसी NTPC </div> <p>As an alternate, these signals from temperature transmitters can be connected to DDCMIS through standard remote I/O modules of the DCS, in which case, the temperature transmitter signals will be acquired through 4-20mA input modules in the remote I/O cabinet for connecting to DDCMIS through remote I/O bus.</p> <p>The no. of such modular systems/ JB's shall be provided as per Appendix-1 to Part-A.</p> <p>Notes (Common for a) to e) above):-</p> <ol style="list-style-type: none"> In case of failure (open or burn-out) of RTD/thermocouple, temp. Transmitter shall provide low temperature output. Composite Accuracy is to be calculated as summation of all applicable accuracies of temp transmitter, for converting sensor input to output in 4-20 mA (e.g., basic accuracy, digital accuracy, D/A accuracy, etc.) and temperature effect on these accuracies at ambient temperature of 50 deg C, based on the figure/ formula given in the standard product catalogue for span as specified above for various types of Temperature Elements specified. All such accuracy/ temp effect figures in catalogue shall be first converted to deg C, and then percentage of this converted accuracy in specified span shall be calculated to compare with the specified composite accuracy figures. <p>3.05.00 Thermo well (for all process temp. elements)</p> <ol style="list-style-type: none"> Shall be one piece solid bored type of 316 SS of step-less tapered design. (As per ASME PTC 19.3 1974) For Mill classifier outlet long life solid sintered tungsten carbide material of high abrasion resistance shall be provided. For Air & Flue gas 316 SS protecting tube with welded cap. (However contractor shall provide better material for Flue gas service if required based on the specified boiler design parameters). For furnace zone, impervious ceramic protecting tube of suitable material along with Incoloy supporting tubes and adjustable flanges. <p>3.06.00 Cold Junction Compensation (CJC) Boxes</p> <table border="0" style="width: 100%;"> <tr> <td style="width: 30%;">a) Ref. temp.</td> <td style="width: 30%;">60°C ± 1.3 °C for type K Thermocouple</td> <td style="width: 30%;"></td> </tr> <tr> <td></td> <td>60°C ± 2°C for type R Thermocouple</td> <td></td> </tr> <tr> <td>b) Effect of ambient temp. variation</td> <td>± 0.1% per 10°C</td> <td></td> </tr> <tr> <td>c) Material</td> <td>4 mm thick fiberglass reinforced polyester with Polyetherene paint & glazed finish.</td> <td></td> </tr> </table>			a) Ref. temp.	60°C ± 1.3 °C for type K Thermocouple			60°C ± 2°C for type R Thermocouple		b) Effect of ambient temp. variation	± 0.1% per 10°C		c) Material	4 mm thick fiberglass reinforced polyester with Polyetherene paint & glazed finish.	
a) Ref. temp.	60°C ± 1.3 °C for type K Thermocouple														
	60°C ± 2°C for type R Thermocouple														
b) Effect of ambient temp. variation	± 0.1% per 10°C														
c) Material	4 mm thick fiberglass reinforced polyester with Polyetherene paint & glazed finish.														
<p>SINGRAULI STPP STAGE-III (1X500 MW) EPC PACKAGE</p>	<p>TECHNICAL SPECIFICATION SECTION - VI PART-B</p>	<p>SUB-SECTION-C-03(A) MEASURING INSTRUMENTS (PRIMARY & SECONDARY)</p>	<p>PAGE 9 OF 45</p>												

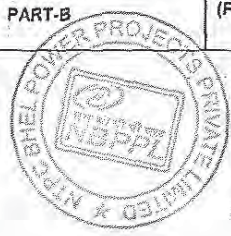

08479

CLAUSE NO.	TECHNICAL REQUIREMENTS																						
	2. Size 3. Display Accuracy Temp. coefficient 4. Mounting 5. Type	48 mm (w) x 24 mm (h)/50 mm x 25 mm 2.5% of final value 0.15% /°C of measured value Flush panel 3½ digit seven segment LED display. Float decimal.																					
4.04.00	Synchronising Relays <p>Synchronising check relay with necessary ancillary equipment shall be provided which shall permit breakers to close after checking the requirements of synchronising of incoming and running supply. The phase angle setting shall not exceed 100 and this angle shall be adjustable and shall take the account the circuit breaker closing period. This relay shall have a response time of less than 200 milliseconds when the two system conditions are met within preset limits and with the timer disconnected. The relay shall have a frequency difference setting not exceeding 0.45% at rated value and at the minimum time setting. The relay shall have a continuously adjustable time setting range of 0.5-3 secs. Additionally, a guard relay shall be provided to prevent the closing attempt by means of synchronising check relay when control switch is kept in closed position long before the two systems are in synchronism. The Control Voltage shall be 220V DC and PT input Voltage shall be 110 V AC.</p>																						
4.05.00	Auxiliary PTs for Measurement & Synchronisation <table border="0" style="width: 100%;"> <tr> <td style="width: 60%;">Applicable Standard</td> <td>IS : 3156</td> </tr> <tr> <td>Rated Voltage</td> <td>110V</td> </tr> <tr> <td>Insulation Level</td> <td>660V grade</td> </tr> <tr> <td>Frequency</td> <td>50 Hz</td> </tr> <tr> <td>Mounting</td> <td>Panel Mounting</td> </tr> <tr> <td>Test Voltage (Power frequency)</td> <td>2.5 KV for 1 min.</td> </tr> <tr> <td>Operating temperature</td> <td>(-) 40⁰C to(+) 85⁰C</td> </tr> <tr> <td>Primary Voltage</td> <td>63.5 V to 115V</td> </tr> <tr> <td>Secondary Voltage</td> <td>63.5 V to 115V</td> </tr> <tr> <td>Class of accuracy</td> <td>1</td> </tr> </table>			Applicable Standard	IS : 3156	Rated Voltage	110V	Insulation Level	660V grade	Frequency	50 Hz	Mounting	Panel Mounting	Test Voltage (Power frequency)	2.5 KV for 1 min.	Operating temperature	(-) 40 ⁰ C to(+) 85 ⁰ C	Primary Voltage	63.5 V to 115V	Secondary Voltage	63.5 V to 115V	Class of accuracy	1
Applicable Standard	IS : 3156																						
Rated Voltage	110V																						
Insulation Level	660V grade																						
Frequency	50 Hz																						
Mounting	Panel Mounting																						
Test Voltage (Power frequency)	2.5 KV for 1 min.																						
Operating temperature	(-) 40 ⁰ C to(+) 85 ⁰ C																						
Primary Voltage	63.5 V to 115V																						
Secondary Voltage	63.5 V to 115V																						
Class of accuracy	1																						
SINGRAULI STPP STAGE-III (1X500 MW) EPC PACKAGE	TECHNICAL SPECIFICATION SECTION - VI PART-B	SUB-SECTION-C-03(A) MEASURING INSTRUMENTS (PRIMARY & SECONDARY)	PAGE 11 OF 45																				

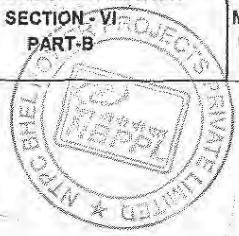

Handwritten signature

08480

CLAUSE NO.	TECHNICAL REQUIREMENTS		
4.06.00	Burden Class of Insulation	25 kA E or better	
5.00.00	Transducers for Electrical Meters Inputs (i) 110V (PT Secondary) 50 Hz (for AC) / 220V DC (for DC) for Voltage transducers. (ii) 110V (PT Secondary) 50 Hz for Frequency Output 2 Nos. isolated 4-20 mA Accuracy $\pm 0.5\%$ of full scale or better. IMPACT HEAD TYPE FLOW ELEMENT Impact head type flow elements shall be used for measurement of CW flow. The impact head type element shall be tubular insert type with four impact ports facing upstream direction, located precisely for determination of average flow velocity and shall be of 316 SS. Accuracy shall be 1.0% of actual value or better. Repeatability shall be + 0.1% of actual value or better. The elements shall be supplied complete with mounting hardware; end support plugs and CS valve manifold (1/2" NPT connection) for instrument connections. All pertinent data including Employer's instrument tag no. for the flow element shall be punched on a stainless steel plate and affixed to the element. Flushing arrangement shall be provided. For quantity and line size etc., refer Appendix-I to Part-A.		
6.00.00	FLUE GAS ANALYSER INSTRUMENTS : Common Requirements 1 Output signals Analog 4-20 mA DC galvanically isolated. If analyser provides superimposed HART signal on 4-20 mA DC output, It shall also be connected to PC based station. Binary 2 NO + 2 NC for high alarm 2 Zero & span Adjustment To be provided with range selection facility.		
SINGRAULI STPP STAGE-III (1X500 MW) EPC PACKAGE	TECHNICAL SPECIFICATION SECTION - VI PART-B	SUB-SECTION-C-03(A) MEASURING INSTRUMENTS (PRIMARY & SECONDARY)	PAGE 12 OF 45

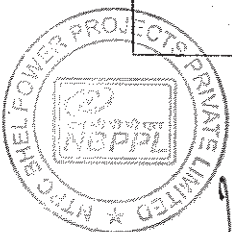

08481

CLAUSE NO.	TECHNICAL REQUIREMENTS		एनटीपीसी NTPC
	3 Ambient temp. 4 Indication 5 Enclosure Type/Material 6 Type of Electronics 7 Digital Signal transmission 8 Calibration 9 Power Supply 10. Others	50°C Digital Alphanumeric Display. Display of reading in engineering units shall be provided. Weather & Dust proof (IP 55) Die cast Aluminium/SS. Microprocessor based with self diagnostic. HART / RS 485 Port Modbus Protocol / Ethernet TCP/IP protocol for communication with plant control system. Auto & Manual (from Remote) To be arranged by Contractor subject to Employer's approval. All interconnection tubing and cabling between probe and analyser / analyser panel and cabling from analyser/ analyser panel to local junction box are to be provided. All the calibration gases required for one year continuous operation shall be provided. The calibration gas container material shall not contaminate the calibration gas.	
SINGRAULI STPP STAGE-III (1X500 MW) EPC PACKAGE	TECHNICAL SPECIFICATION SECTION - VI PART-B	SUB-SECTION-C-03(A) MEASURING INSTRUMENTS (PRIMARY & SECONDARY)	PAGE 13 OF 45

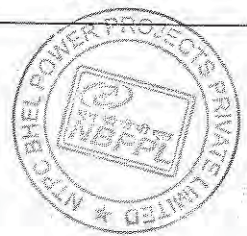

Specification Requirements system	SO2 Analyser and Nox Analyser cum monitor (combined)	Oxygen Analyser cum monitor (High temp.)	Low Temp. O2 Analyser cum monitor	CO Analyser cum monitor	Dust density Stack Opacity monitoring	CO2 ANALYZER
Type of Instrument	Sampling type	Non-heated in-situ dry type	Heated type in-situ	In-Situ type	In-Situ dry type visible light (through LED) stack	In-situ or Extractive
Principle of Measurement	Radiation absorption	Partial-pressure using Zirconium Oxide Cell	Partial-pressure using zirconium oxide cell	IR absorption	Transmission and absorption	NDIR Absorption
Measurement Range	0-300 ppm/ 0-1000ppm Selectable	0.01% to 10% oxygen	0 to 25% oxygen programmable upto min 0.5% of O ₂	0-200, 0-1000 ppm, programmable.	0 to 999mg/m ² , programmable.	0 to 40%(fully selectable)
Accuracy	+/- 1% of F.S.	+/-1% of F.S. or 0.5 % O ₂ whichever is more	+/-1% of Full Scale	+/- 5% of F.S.	2% of F.S.	+/-2% of measured value
Linearity	+/- 1% of F.S.	+/- 1% of F.S.	+/- 1% of F.S.	+/-2% of F.S.	+/- 1% of F.S.	+/- 1% of F.S.
Repeatability	≤ 1% of Span	≤ 0.5% of Span	≤ 0.5% of Span	≤ 0.5% of Span	≤ 1% of Span	≤ 0.5% of Span
Response time (up to 90% of full scale)	≤ 5 secs	≤ 5 secs	≤ 5 secs	≤ 5 secs	≤ 5 secs	≤ 5 secs
a) Temperature Drift	+/- 2% / 10 deg.C	-	-	Automatic temp compensation	+/- 1% in 24 hrs	+/- 1% in 24 hrs
b) Zero Drift	< 1% span/week	-	< 1% span/week	<1% span/week	< 1% span/week	< 1% span/week
c) Span Drift	< 1% measured value/week	Stability:- 1% deviation through out life of sensor	< 1% measured value/week	< 1% measured value / week	< 1% measured value/week	< 1% measured value/week
Operating	0-300 deg.C	600-1600 deg.C	0-450 deg.C	0-300 deg.C	0-300 deg.C	0-300 deg.C

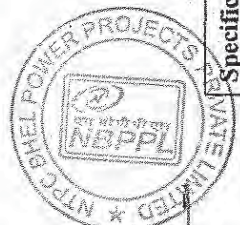

SINGRAULI STPP STAGE-III (1X500 MW) EPC PACKAGE	TECHNICAL SPECIFICATION SECTION - VI PART-B	SUB-SECTION-C-03(A) MEASURING INSTRUMENTS (PRIMARY & SECONDARY)	PAGE 14 OF 45
---	---	---	------------------

8483

Temperature Range									
Filter	Ceramic 3.5 Micron	Cell shall be protected using ceramic boot	Suitable filter to be provided	Not Applicable	To be provided	Ceramic 3.5 Micron if extractive type			
Accessories purging system	Purging system (Auto Scavenging facility)	Not applicable	Not applicable	Purging system to be provided with heavy duty blowers and shutter mechanism for automatic isolation of lens during purge air failure.	Purging system to be provided with heavy duty blowers and shutter mechanism for automatic isolation of lens during purge air failure.				
Temperature	Temperature of the sample shall be controlled before analyser.	Yes With R/B type thermocouples (to be finalised during detailed Engineering) required.	Automatic temperature control of heating circuit through thermostat.	Automatic temperature control	Yes	Yes			
Location	On chimney	SH Zone	Air heater inlet	Chimney.	On Chimney	On Chimney			

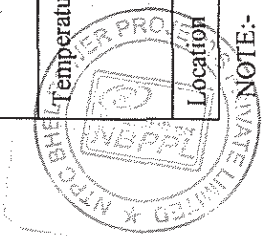

- NOTE:-
01. Sampling type systems shall be provided with dual sample probes along with all required accessories such as redundant heavy duty pumps with continuous rated motors, moisture detection facility, pre-fabricated heated sample lines from probes to analyser panel, solenoid valves, filters, coolers along with level switch in gas coolers for auto draining purpose and flow meter etc.
 02. For O₂ Analyser, the construction of the sensor shall be such that joints between dissimilar materials are avoided to prevent formation of cracks.
 03. Note:- If Extractive type CO₂ analyzer is provided, it shall be combined with SO₂ and NO_x analyzer. If In situ analyzer is provided, it shall be combined with CO analyzer.
 04. If the Sox, NO_x and CO₂ (if extractive type) analyzers do not meet the environmental conditions specified at cl. 7.00.00 of Sub Sec IIIC-01, panel AC shall be provided in analyzer cabinets to meet the requirement.

SINGRAULI STPP STAGE-III (1X500 MW) EPC PACKAGE	TECHNICAL SPECIFICATION SECTION - VI PART-B	SUB-SECTION-C-03(A) MEASURING INSTRUMENTS (PRIMARY & SECONDARY)	PAGE 15 OF 45
---	---	---	------------------

08495

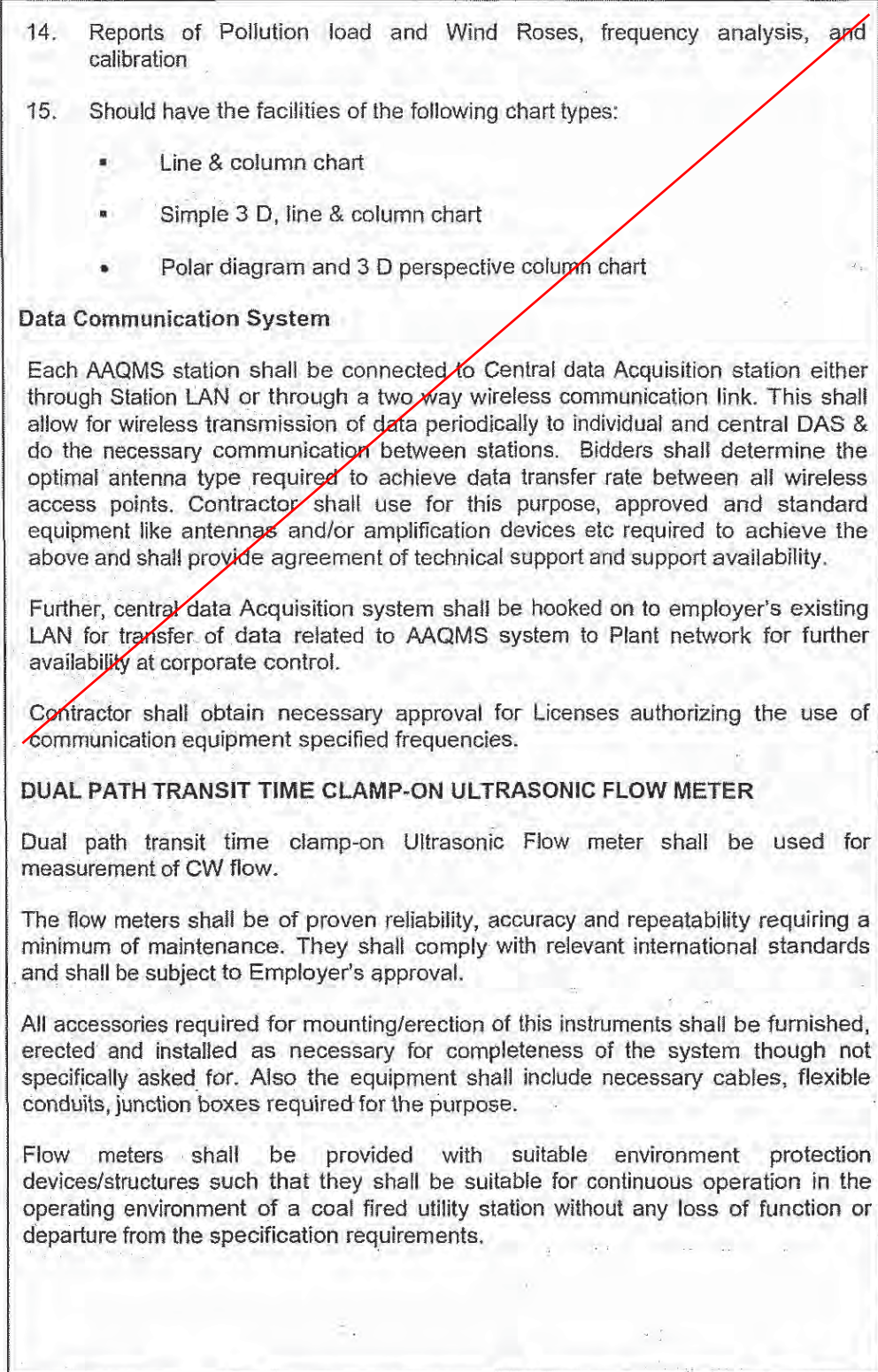
CLAUSE NO.	MEASURING INSTRUMENTS (C-03)			
11.03.03	<p>14. Reports of Pollution load and Wind Roses, frequency analysis, and calibration</p> <p>15. Should have the facilities of the following chart types:</p> <ul style="list-style-type: none"> ▪ Line & column chart ▪ Simple 3 D, line & column chart • Polar diagram and 3 D perspective column chart 			
	<p>Data Communication System</p> <p>Each AAQMS station shall be connected to Central data Acquisition station either through Station LAN or through a two way wireless communication link. This shall allow for wireless transmission of data periodically to individual and central DAS & do the necessary communication between stations. Bidders shall determine the optimal antenna type required to achieve data transfer rate between all wireless access points. Contractor shall use for this purpose, approved and standard equipment like antennas and/or amplification devices etc required to achieve the above and shall provide agreement of technical support and support availability.</p> <p>Further, central data Acquisition system shall be hooked on to employer's existing LAN for transfer of data related to AAQMS system to Plant network for further availability at corporate control.</p> <p>Contractor shall obtain necessary approval for Licenses authorizing the use of communication equipment specified frequencies.</p>			
12.00.00	<p>DUAL PATH TRANSIT TIME CLAMP-ON ULTRASONIC FLOW METER</p>			
12.01.00	<p>Dual path transit time clamp-on Ultrasonic Flow meter shall be used for measurement of CW flow.</p>			
12.02.00	<p>The flow meters shall be of proven reliability, accuracy and repeatability requiring a minimum of maintenance. They shall comply with relevant international standards and shall be subject to Employer's approval.</p>			
12.03.00	<p>All accessories required for mounting/erection of this instruments shall be furnished, erected and installed as necessary for completeness of the system though not specifically asked for. Also the equipment shall include necessary cables, flexible conduits, junction boxes required for the purpose.</p>			
12.04.00	<p>Flow meters shall be provided with suitable environment protection devices/structures such that they shall be suitable for continuous operation in the operating environment of a coal fired utility station without any loss of function or departure from the specification requirements.</p>			
<p>SINGRAULI STPP STAGE-III (1X500 MW) EPC PACKAGE</p>	<p>TECHNICAL SPECIFICATION SECTION - VI PART-B</p>	<p>SUB-SECTION-C-03(A) MEASURING INSTRUMENTS (PRIMARY & SECONDARY)</p>	<p>PAGE 27 OF 45</p>	

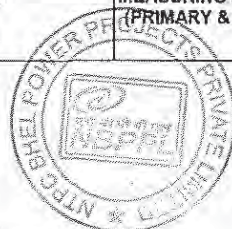

08496

CLAUSE NO.	MEASURING INSTRUMENTS (C-03)			
12.05.00	TECHNICAL REQUIREMENTS			
Type	Transit time Clamp On Ultrasonic meter			
Mounting Style	Dual path with two sets of transducers on the same pipe			
Flow measurement	Instantaneous Flow rate as well as totalized flow			
Power supply	230 V AC			
Outputs : Analog Current Binary Communication ports	Isolated 4-20mA linear outputs for each path Contact relay outputs, 2 NO + 2 NC for alarm RS 232 C digital Hand held terminal port			
Display/Indication	Flow meter with LCD screen backlight based local display and keypad . If required, transmitter shall be suitably located away from the sensor for better access and visibility.			
Recording / Totalizing/Logging Facilities	Yes. Should be able to compute cumulative flow over intervals selectable by owner i.e., daily, weekly, monthly etc. The data shall be stored in the memory of flow computer for access in future.			
Software features	Compensation for any cross path errors Programming, configuration, shall be possible from front panel.			
Diagnostics	False signal tolerance , power supply failure etc			
Protection class	IP-65 or better, Weather protection against direct sunlight, rain etc for Flow meter and suitable for Cooling water for Transducer			
SINGRAULI STPP STAGE-III (1X500 MW) EPC PACKAGE	TECHNICAL SPECIFICATION SECTION - VI PART-B	SUB-SECTION-C-03(A) MEASURING INSTRUMENTS (PRIMARY & SECONDARY)	PAGE 28 OF 45	

