

| | | | |
|---|--|--------------------------------------|-----------------|
|  | TITLE | SPECIFICATION NO. PE-TS-888-100-A001 | |
| | TECHNICAL SPECIFICATION FOR SEAWORTHY PACKING FOR EXPORT JOBS | VOLUME II B | |
| | | SECTION D | |
| | | REV. NO. 0 | DATE 10/08/2010 |
| | | SHEET 10 | OF 52 |

Electrical equipment such as, switchboards, electric motors, sensitive equipment, with non-corrosion guarantee, for a period up to twelve (12) months.

8.4.5.2 Type of Construction

Type of construction as indicated in article 8.4.2.2. Preservation by sealing an aluminium compound foil, with the addition of desiccants. Humidity indicators, if required and installed in the barrier wrapping, shall allow easy control from the outside.

Additional marking:

- Case with desiccants.

Packing Category V/VI

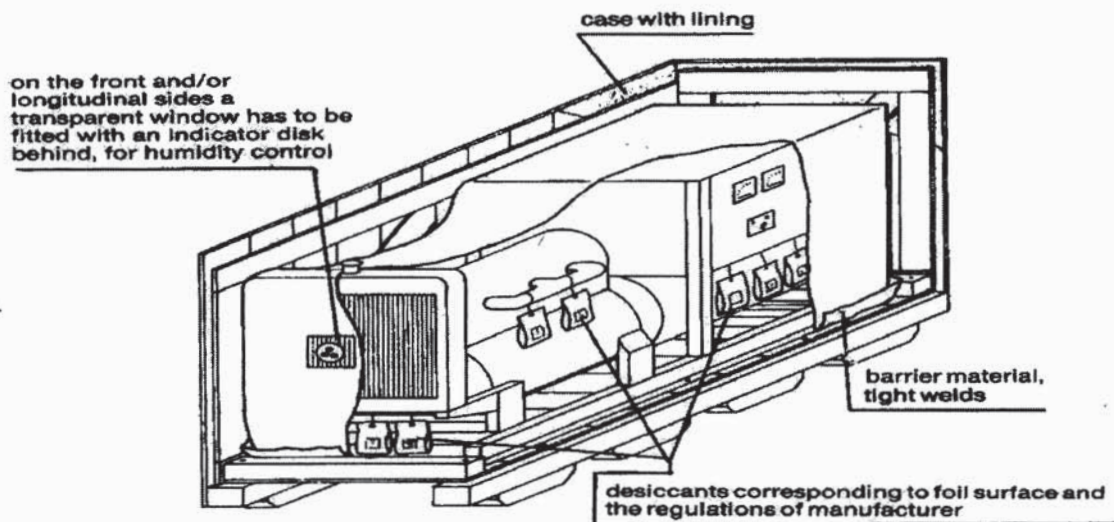

8.4.6 Double Case – Packing Category VII

8.4.6.1 Type of Equipment

GOODS which are of high sensitivity to shock, impact and vibration, for instance, special electrical equipment like computers, switchboards, laboratory instruments

8.4.6.2 Type of Construction

Case construction as indicated in article 8.4.2.2, with additional floating inner packing (case-in-case principle), padding corresponding to weight and sensitiveness. Preservation by sealing in aluminium compound foil with the addition of desiccants. The inner case has to be made of plywood or equivalent material with a thickness of 8-12 mm, depending on the weight of the GOODS to be packed. The inner buckles and/or frame borders have to be dimensioned so that the full stability of the inside case will be reached and no twisting is possible. The inner sides of the inside case will be lined with bituminous kraft paper on all sides (except bottom).

| | | | |
|---|--|--------------------------------------|-----------------|
|  | TITLE | SPECIFICATION NO. PE-TS-888-100-A001 | |
| | TECHNICAL SPECIFICATION FOR SEAWORTHY PACKING FOR EXPORT JOBS | VOLUME II B | |
| | | SECTION D | |
| | | REV. NO. 0 | DATE 10/08/2010 |
| | | SHEET 11 | OF 52 |

8.4.7 Cable Drum – Packing Category VIII

8.4.7.1 Type of Equipment

All type of cables, wires, ropes, hoses.

8.4.7.2 Type of Construction

For all type of cables refer clause no. 11.1. For other items (wires, ropes, hoses) new or practically new drums are to be used. Planking of the e drums by use of boards, thickness minimum 20 mm, with additional double steel strapping, nailed, and carefully preserved/ protected cable ends prior to packing.

8.4.8 Hazardous Materials – Packing Category IX

8.4.8.1 Type of Equipment

Hazardous materials according to the law are explosives, compressed gases, liquefied gases dissolved under pressure or deeply refrigerated, flammable liquids, flammable solids: substances liable to spontaneous combustion; substances which, on contact with water, emit flammable gases, oxidizing substances, organic peroxides, poisonous (toxic) and infectious substances; radioactive materials, corrosives, miscellaneous dangerous goods.

8.4.8.2 Type of Construction

Hazardous materials shall always be packed and documented separately from any other material. Selection of packaging materials, execution of packing and marking as well as documentation shall always be in compliance with the applicable laws and regulations. Any certificates required for transportation or for authorities to be supplied before shipment of the GOODS.

8.4.9 Wooden Floor as a Transport Support – Packing Category X

8.4.9.1 Type of Equipment

Any materials to be stuffed in containers or on flat racks and that are not stowed on standard pallets or otherwise suitably packed

8.4.9.2 Type of Construction

- Longitudinal internal square timbers bolted to the front wall runners, longitudinal skid.
- Maximum distance between longitudinal runners 90 cm (middle to middle of the runner).
- Full boarding of the floor.
- Attaching of lifting lugs and/or iron ropes for lifting/pulling the units off the transport equipment.
- If applicable, preservation of the equipment by sealing in polyethylene-foil or aluminium compound foil and the addition of desiccants.

8.5 Air Transport Packing

8.5.1 General

Certain types of material may have to be shipped by air from their country of origin. This means of transport will be exceptional, and will be used only:

- For GOODS, which are highly sensitive to shock or vibrations, such as computers, electronic instruments, or those of small dimensions and weight.
- For GOODS urgently required at the module yard(s) and/or jobsite.

| | | | | |
|---|--|--------------------------------------|-----------------|----|
|  | TITLE | SPECIFICATION NO. PE-TS-888-100-A001 | | |
| | TECHNICAL SPECIFICATION FOR SEAWORTHY PACKING FOR EXPORT JOBS | VOLUME II B | | |
| | | SECTION D | | |
| | | REV. NO. 0 | DATE 10/08/2010 | |
| | | SHEET 12 | OF | 52 |

8.5.2 Type of Packing

Depending on the goods to be packed, VENDOR may use one of the following types:

- A triple-corrugated cardboard container made with waterproofed glue and a barrier layer of polyethylene on the outsides to keep out humidity.
- Wooden/cardboard packing cases: the wood being used for the framework and base of the cases, waterproofed triple-corrugated cardboard being used for the sides and top. These cases are of the "Bell" type, and used for material of small or medium dimensions.
- For larger dimensions, plywood cases are acceptable. The timber characteristics, cross-sections and thickness will be systematically determined by the nature of the loads to be packed.

8.5.3 Dimensions

In order to optimize the existing transport facilities (passenger or cargo aircraft), the dimensions of:

- Triple-corrugated containers.
 - Wooden/cardboard packing cases.
 - Plywood cases.
- Are to be adapted to pallets used for air transportation.

9.0 Detailed specification for Wooden Crates/Boxes/Cases and other packing materials

9.1 Technical specification for wood

The wood shall be Fir, Chir, Silver Oak (Gravillea Robusta), chemically treated mango and Pinewood with moisture content not exceeding 50%. The wood shall have flexural and compressive strength, stiffness, shock absorption and nail retention properties. The wood shall be free from common defects such as warp, bone, twist, knot, cracks, splits, end splits, bend, visible sign of infection and any kind of decay caused by insects or fungus, etc. Surface cracks with maximum depth of 3mm are permissible. A continuous crack of any depth all along the length is not allowed.

9.2 Chemical Treatment of Wood:

The wood shall be chemically treated to provide protection against deterioration due to fungi and attack by termites, borers, marine organism and any other kind of infection. It shall be treated only after final processing like cutting, planning, joint grooving, etc.

9.3 TYPE, DESIGN & DIMENSION OF WOODEN PACKING CASES:

9.3.1 PACKING OF EQUIPMENTS

Various mechanical, electrical and C&I equipment e.g. Pumps, motors, equipment skids, heat exchangers, control panels, switch gears, transformers, etc. shall be wrapped in weather proof packing and then secured in wooden packing cases. The construction of wooden packing cases/crates shall be as per details given below and also given in figure 1 to 11.

9.3.1.1 Bottom Frame

| | | | | |
|---|--|---|-----------------|-------|
|  | TITLE | SPECIFICATION NO. PE-TS-888-100-A001 | | |
| | TECHNICAL SPECIFICATION FOR SEAWORTHY PACKING FOR EXPORT JOBS | VOLUME | | II B |
| | | SECTION | | D |
| | | REV. NO. 0 | DATE 10/08/2010 | |
| | | SHEET | 13 | OF 52 |

The construction of bottom frame shall be as per Fig-2. The No. of slides/runners for bottom frames shall be selected depending upon the weight and overall dimensions of the load to be carried. The equipment shall be secured by fixing their base frame/plate with the help of bolt and nuts etc. to bottom frame of the wooden packing cases/crates. The equipment not provided with base frame/plate like cylindrical vessels, etc to be secured to the bottom frame of the wooden cases with "C" clamps fabricated from steel channels/ angle iron.

9.3.1.2 TOP FRAME

The construction of top frame shall be as per fig-3.

9.3.1.3 END PANELS

The dimension of the end and lateral panels shall be calculated according to overall dimensions of the items to be packed. Diagonal braces shall be used for packing cases having height exceeding 500mm. Details of bracings shall be as per fig 5 to 9.

9.3.1.4 Sling Plate

To facilitate lifting of cases, longitudinal under slide boards shall be fixed. To avoid damage to the box while lifting sling plates shall be provided. Refer fig-11.

9.3.1.5 Angle Iron Cleats

Angle iron cleats shall be used for strengthening the joints as indicated in fig-10

9.3.1.6 Other Requirements

- The thickness of planks for top, bottom, side and end panels shall be at least 25mm. Planks used for this purpose shall be joined with each other by tongue and groove joint. The groove dimension shall be such that tongue fits tightly into groove to make the joint.
- Runners/slides, traverse bars, etc shall be of single length i.e. without any joint. Planks for sheathing, diagonal bracing etc shall also be of single length up to 2400mm, proper jointing is permitted for planks for sheathing and diagonal bracings.
- Each equipment to be individually covered with double polyethylene petticoat. Sheet thickness of polythene sheet shall not be less than 0.175 mm (175 microns). The sealing shall be such so as not to allow moisture inside.
- The inner surface of 4 sides of shooks shall be nailed with bituminized water proof craft paper. Wherever 2 pieces of kraft paper are used, joint shall have an overlap of minimum 20 mm.
- All the inner sides of the box shall be nailed with bitumen coated HESSIAN POLYTHYLENE KRAFT PAPER. For top frame it shall project on all sides by 100mm and shall be nailed on sides. Wherever 2 pieces of kraft paper are used, joint shall have an overlap of minimum 20 mm.
- For delicate equipment like control panels and switchgears, lighting panels and lighting transformers, suitable cushioning material like rubberised coir (min. 50 mm thick and 100 mm wide) shall be provided on their bottom support and the gap between the panel and casing

| | | | |
|---|--|---|-----------------|
|  | TITLE | SPECIFICATION NO. PE-TS-888-100-A001 | |
| | TECHNICAL SPECIFICATION FOR SEAWORTHY PACKING FOR EXPORT JOBS | VOLUME II B | |
| | | SECTION D | |
| | | REV. NO. 0 | DATE 10/08/2010 |
| | | SHEET 14 | OF 52 |

shall be filled with rubberized coir with distance between consecutive supports less than 500 mm (ref fig15). For other equipment suitable support from sides of the casing shall be provided.

- Switchgear cubicles, control panels and control desks shall be packed and shipped in separate convenient sections. The components e.g. circuit breakers relays and instruments etc. which are removed from panels for shipping purpose and shall be separately packed and shipped as per packing instructions in clause 10.4.
- Packing case for control panels and switchgear panels shall be finally covered with GI sheet of minimum thickness of 0.4mm.
- Packing cases shall be bound at edges by nailing MS clamps/brackets at sufficient intervals. Further heavier boxes shall be strapped with C clamps (ref fig-4) fabricated from steel channels/angles and lighter boxes shall be strapped with hoop iron strips.
- Silica gel is used for this purpose to protect contents over sufficiently long time from corrosion. Silica gel shall be indicating type confirming to IS-304 (1979) packed in cotton bags placed at different positions inside the packing for absorbing moisture and shall not come into directly contact with equipment/material inside the package. The quantity of silica gel shall be adequate for storage period of one year, however it shall not be less than 4 gm. per ltr. Volume of case subject to minimum 400 gm. Per case.

| | | | |
|---|--|--------------------------------------|-----------------|
|  | TITLE | SPECIFICATION NO. PE-TS-888-100-A001 | |
| | TECHNICAL SPECIFICATION FOR SEAWORTHY PACKING FOR EXPORT JOBS | VOLUME II B | |
| | | SECTION D | |
| | | REV. NO. 0 | DATE 10/08/2010 |
| | | SHEET 15 | OF 52 |

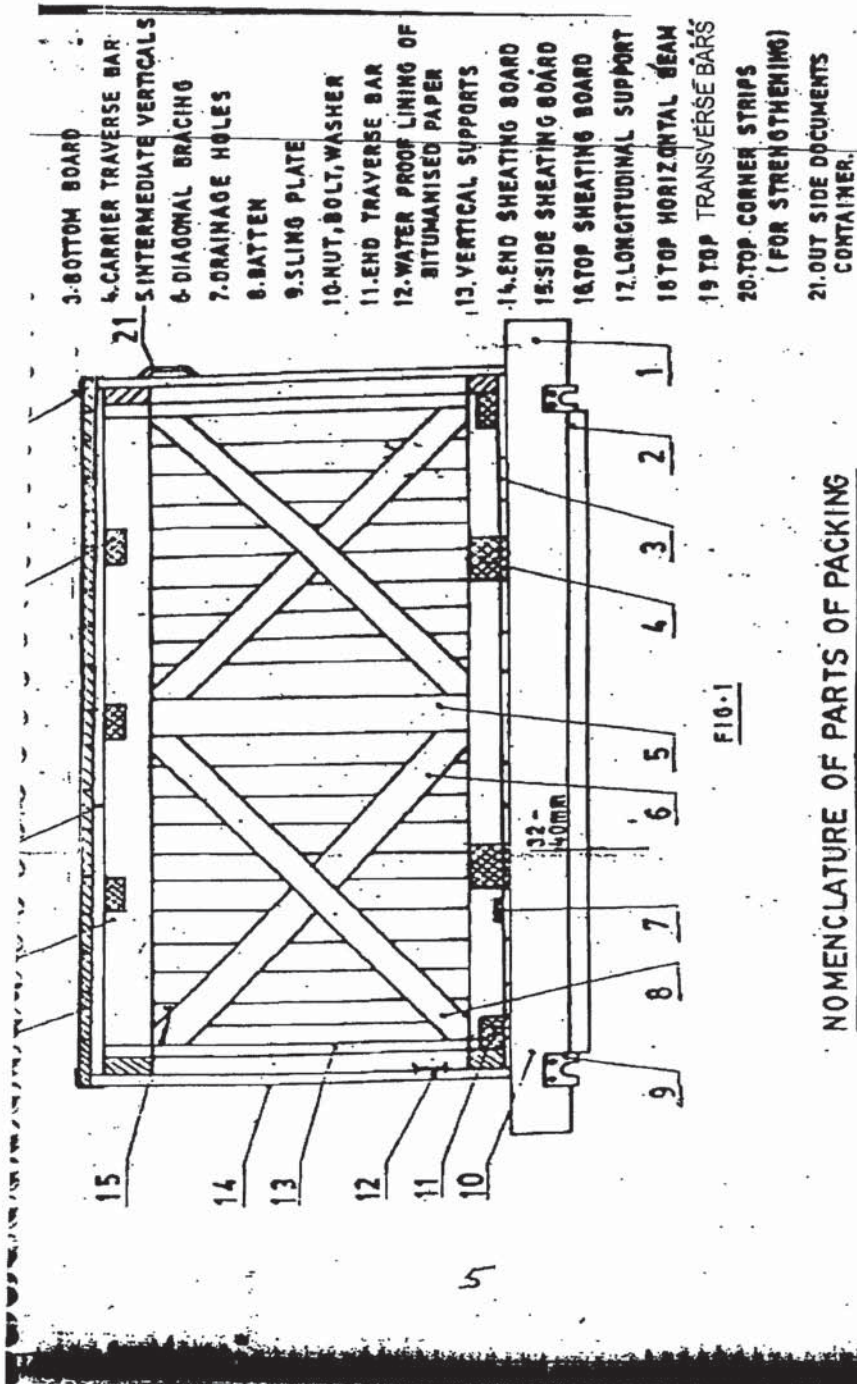

- 3. BOTTOM BOARD
- 4. CARRIER TRAVERSE BAR
- 5. INTERMEDIATE VERTICALS
- 6. DIAGONAL BRACING
- 7. DRAINAGE HOLES
- 8. BATTEN
- 9. SLING PLATE
- 10. NUT, BOLT, WASHER
- 11. END TRAVERSE BAR
- 12. WATER PROOF LINING OF BITUMANISED PAPER
- 13. VERTICAL SUPPORTS
- 14. END SHEATHING BOARD
- 15. SIDE SHEATHING BOARD
- 16. TOP SHEATHING BOARD
- 17. LONGITUDINAL SUPPORT
- 18. TOP HORIZONTAL BEAM
- 19. TOP TRANSVERSE BARS
- 20. TOP CORNER STRIPS (FOR STRENGTHENING)
- 21. OUT SIDE DOCUMENTS CONTAINER.

EC-009

| | | | | |
|---|--|--------------------------------------|-----------------|----|
|  | TITLE | SPECIFICATION NO. PE-TS-888-100-A001 | | |
| | TECHNICAL SPECIFICATION FOR SEAWORTHY PACKING FOR EXPORT JOBS | VOLUME II B | | |
| | | SECTION D | | |
| | | REV. NO. 0 | DATE 10/08/2010 | |
| | | SHEET 16 | OF | 52 |

BOTTOM FRAME ARRANGEMENTS

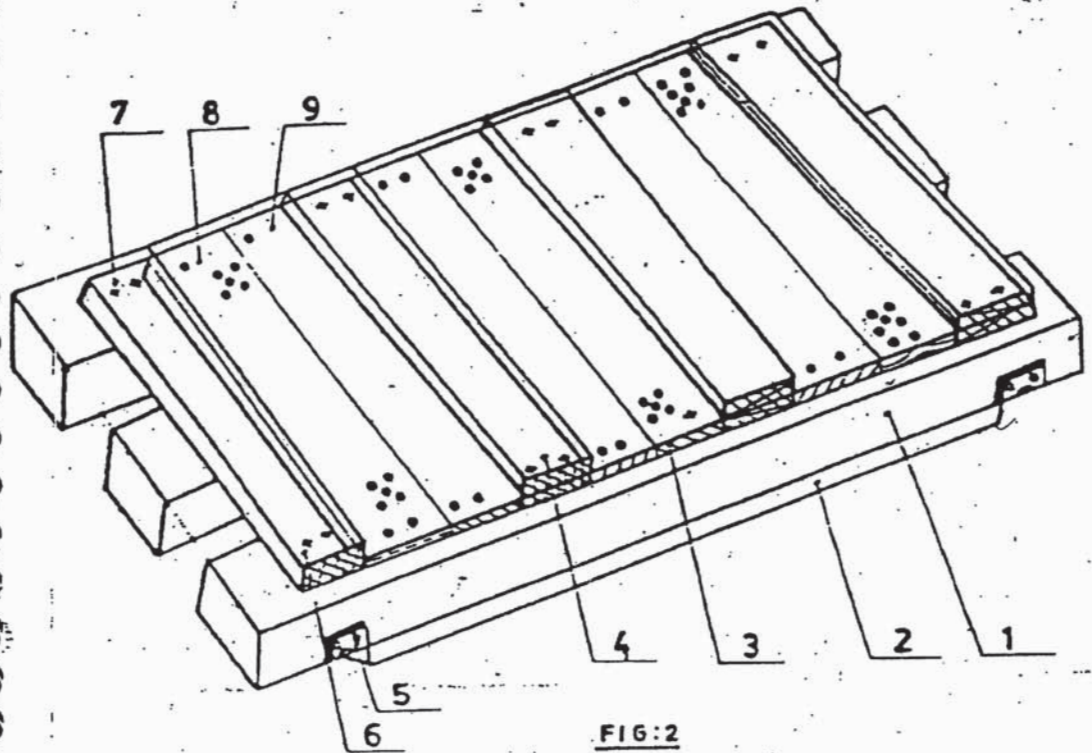



FIG:2

Nos. of slides: Minimum 2 Nos.
 For length more than 1800 mm or
 load more than 1000kg, nos. of
 slides shall be minimum 3 nos.
 For dimensions of slides, refer Table 1
 Cross section of end traverse bar; 100 x 100 mm.
 (minimum)

- 1. SLIDE
- 2. UNDER SLIDE BOARD
- 3. BOTTOM BOARD
- 4. CARRIER TRAVERSE BAR
- 5. SLING PLATE
- 6. TRAVERSE BAR
- 7. BOLT, NUT & WASHER
- 8. DRAINAGE HOLES
- 9. NAILS

6

027

| | | | |
|---|--|--------------------------------------|-----------------|
|  | TITLE | SPECIFICATION NO. PE-TS-888-100-A001 | |
| | TECHNICAL SPECIFICATION FOR SEAWORTHY PACKING FOR EXPORT JOBS | VOLUME II B | |
| | | SECTION D | |
| | | REV. NO. 0 | DATE 10/08/2010 |
| | | SHEET 17 | OF 52 |

TOP FRAME ARRANGEMENT

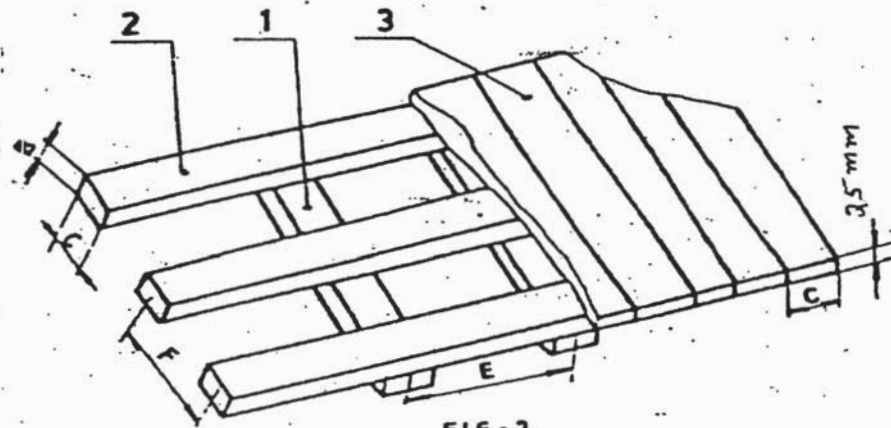
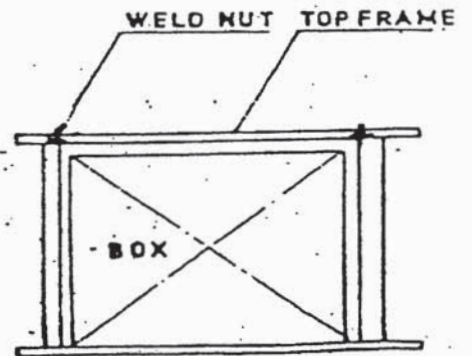
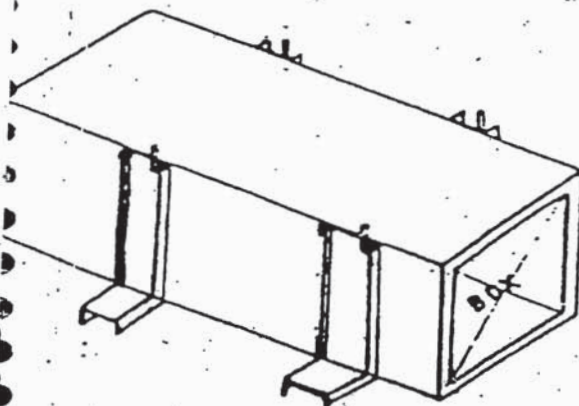

FIG-3

F : 700 t. 1000 mm
 E : 500 t. 900 mm
 30x100 mm.

- 1 - Traverse Bars
- 2 - Horizontal Soans
- 3 - Top Board

ARRANGEMENT OF C-CLAMPS AROUND CASES



028

| | | | |
|---|--|--------------------------------------|-----------------|
|  | TITLE | SPECIFICATION NO. PE-TS-888-100-A001 | |
| | TECHNICAL SPECIFICATION FOR SEAWORTHY PACKING FOR EXPORT JOBS | VOLUME II B | |
| | | SECTION D | |
| | | REV. NO. 0 | DATE 10/08/2010 |
| | | SHEET 18 | OF 52 |

**ARRANGEMENT OF DIAGONAL BRACING AND
HORIZONTAL SUPPORT**

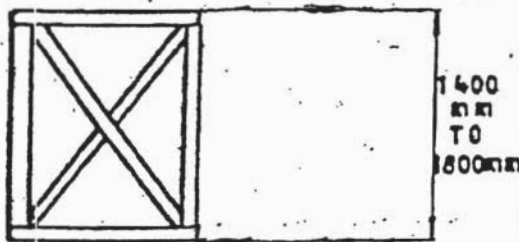

FIG:6

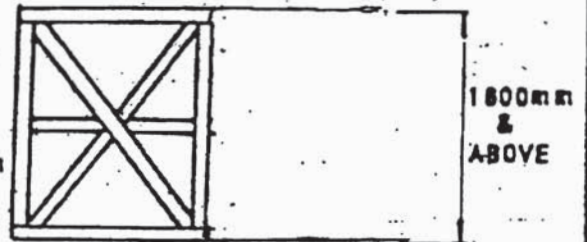

FIG:8

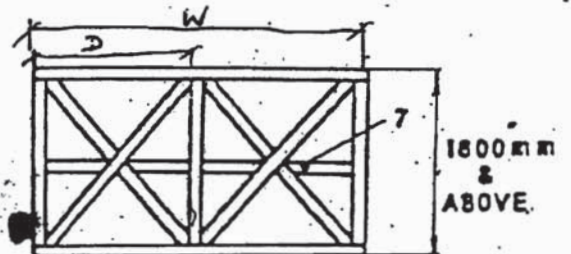

FIG:9

7- Middle Horizontal Support

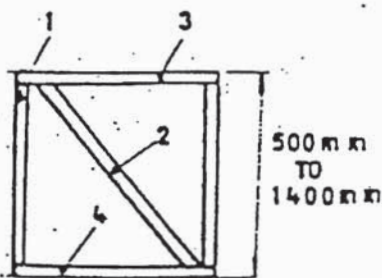

FIG:5

1- Vertical Support

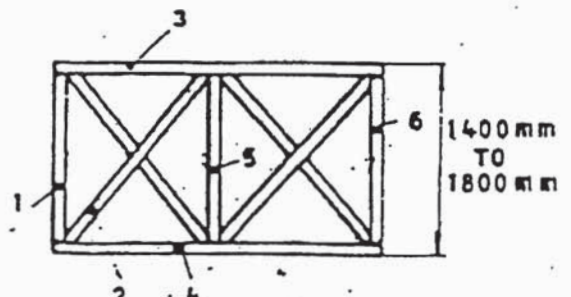



FIG:7

1, 5, 6 - Vertical Support

029

| | | | |
|---|---|--------------------------------------|-----------------|
|  | TITLE | SPECIFICATION NO. PE-TS-888-100-A001 | |
| | TECHNICAL SPECIFICATION FOR SEAWORTHY PACKING FOR EXPORT JOBS | VOLUME II B | |
| | | SECTION D | |
| | | REV. NO. 0 | DATE 10/08/2010 |
| | | SHEET 19 OF 52 | |

ARRANGEMENT OF PACKING CASE

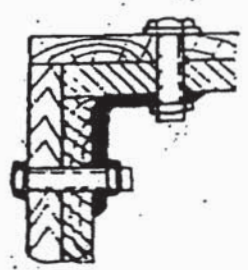
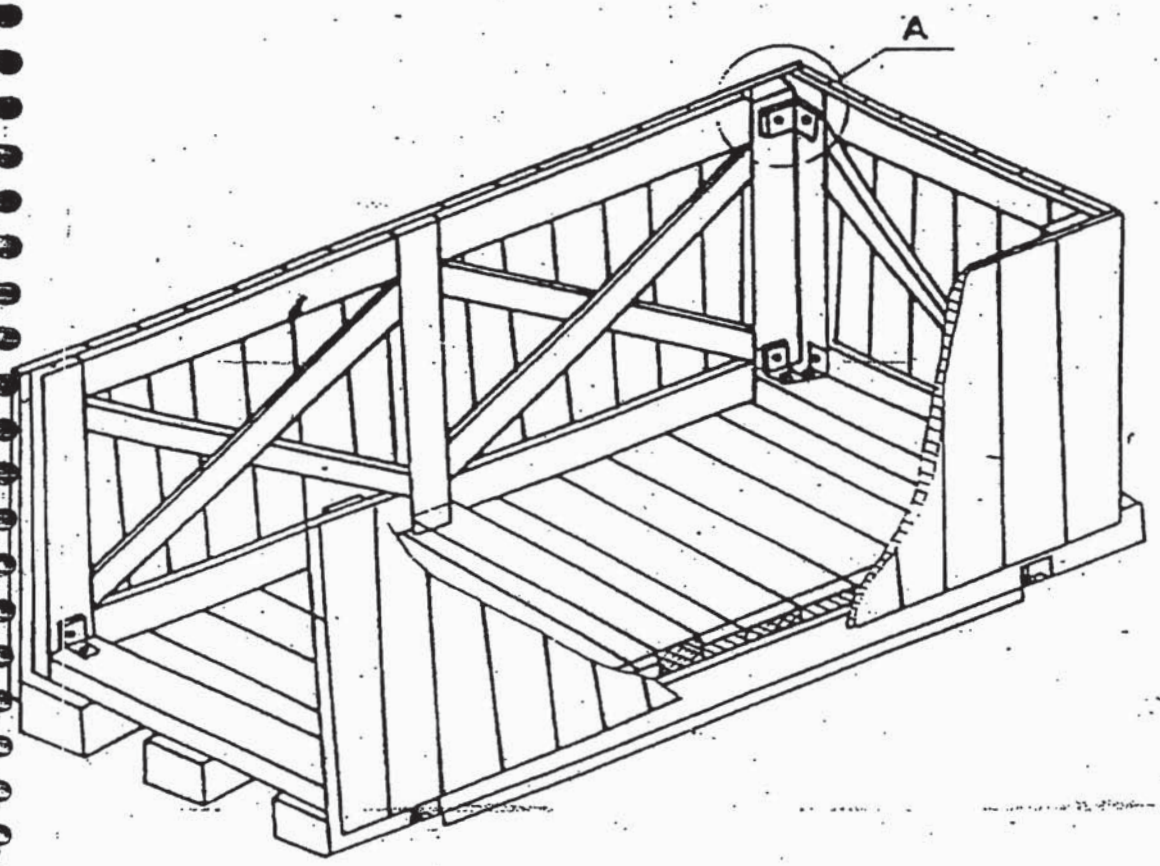

DETAIL-A

HOLE DIAMETER
MUST CONFORM
TO BOLT DIA

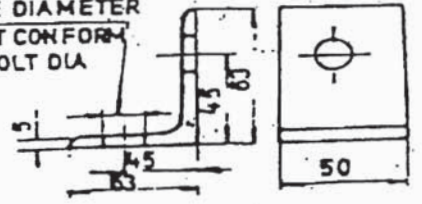



FIG:10

030

| | | | |
|---|---|--------------------------------------|-----------------|
|  | TITLE | SPECIFICATION NO. PE-TS-888-100-A001 | |
| | TECHNICAL SPECIFICATION FOR SEAWORTHY PACKING FOR EXPORT JOBS | VOLUME II B | |
| | | SECTION D | |
| | | REV. NO. 0 | DATE 10/08/2010 |
| | | SHEET 20 OF 52 | |

ARRANGEMENT OF SLING & PLATE ON

CASES

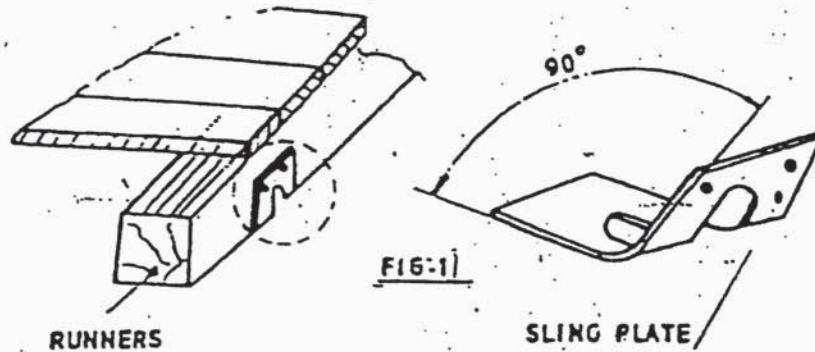



| | | | |
|---|--|--------------------------------------|-----------------|
|  | TITLE | SPECIFICATION NO. PE-TS-888-100-A001 | |
| | TECHNICAL SPECIFICATION FOR SEAWORTHY PACKING FOR EXPORT JOBS | VOLUME II B | |
| | | SECTION D | |
| | | REV. NO. 0 | DATE 10/08/2010 |
| | | SHEET 21 | OF 52 |

TABLE-1

| LOADS | LENGTHS OF SLIDES | | | | | | |
|-------|------------------------|-----|------|------|---|------|------|
| | 600 | 800 | 1000 | 1200 | 1300 | 1500 | 2000 |
| | Cross section b x c | | | |  | | |
| 500 | 50 | 50 | 50 | 50 | 75 | 75 | 100 |
| | X | X | X | X | X | X | X |
| 800 | 100 | 100 | 100 | 100 | 100 | 100 | 100 |
| | 50 | 50 | 75 | 75 | 75 | 75 | 100 |
| 1000 | X | X | X | X | X | X | X |
| | 100 | 100 | 100 | 100 | 100 | 110 | 150 |
| 1500 | 75 | 75 | 100 | 100 | 100 | 100 | 100 |
| | X | X | X | X | X | X | X |
| 2000 | 100 | 100 | 100 | 100 | 100 | 150 | 150 |
| | 75 | 100 | 100 | 100 | 100 | 100 | 150 |
| 2500 | X | X | X | X | X | X | X |
| | 100 | 100 | 150 | 150 | 150 | 150 | 150 |
| 3000 | 100 | 100 | 150 | 150 | 150 | 150 | 150 |
| | X | X | X | X | X | X | X |
| | 100 | 150 | 150 | 150 | 150 | 150 | 150 |









| | | | | | | | |
|---|--|---|--|--------------|------------------------|--|--|
|  | TITLE TECHNICAL SPECIFICATION FOR SEAWORTHY PACKING FOR EXPORT JOBS | SPECIFICATION NO. PE-TS-888-100-A001 | | | | | |
| | | VOLUME II B | | | | | |
| | | SECTION D | | | | | |
| | | REV. NO. 0 | | | DATE 10/08/2010 | | |
| | | SHEET 22 | | OF 52 | | | |

Table-2







| End and side panels | Width of the panel "W" | Distance between longitudinal support (Dimension "D") | | | | | | |
|---------------------|------------------------|---|----------------|----------------|----------------|----------------|----------------|----------------|
| | | 600 | 800 | 1000 | 1200 | 1400 | 1600 | 1800 |
| | | Cross section b x c | | | | Item 1 to 7 | | |
| Fig- 5 to Fig-9 | 600 to 1200 | 30 X 100 | 30 X 100 | 30 X 100 | 30 X 130 | 30 X 130 | 30 X 130 | 30 X 130 |
| | 1201 to 1600 | 30 X 130 | 30 X 130 | 30 X 130 | 30 X 130 | 30 X 130 | 30 X 130 | 30 X 130 |
| | 1601 to 2000 | 30 X 130 | 30 X 130 | 30 X 130 | 30 X 130 | 30 X 130 | 30 X 130 | 30 X 130 |
| | 2001 to 3000 | 30 X 130 | 30 X 130 | 30 X 130 | 30 X 130 | 30 X 130 | 30 X 130 | 40 X 150 |
| | 3001 to 4000 | 40 X 150 | 40 X 150 | 40 X 150 | 40 X 150 | 40 X 150 | 40 X 150 | 40 X 150 |

| | | | |
|---|--|--------------------------------------|-----------------|
|  | TITLE | SPECIFICATION NO. PE-TS-888-100-A001 | |
| | TECHNICAL SPECIFICATION FOR SEAWORTHY PACKING FOR EXPORT JOBS | VOLUME II B | |
| | | SECTION D | |
| | | REV. NO. 0 | DATE 10/08/2010 |
| | | SHEET 23 | OF 52 |

INDICATION MARKS ON CASES/BOXES/CRATES

| Designation | Symbol | Explanation |
|---|---|--|
| Fragile, Handle with care |  | The symbol should be applied to easily broken cargoes. Cargoes marked with this symbol should be handled carefully and should never be tipped over or slung. |
| Use no hooks |  | Any other kind of point load should also be avoided with cargoes marked with this symbol. The symbol does not automatically prohibit the use of the plate hooks used for handling bagged cargo. |
| Top |  | The package must always be transported, handled and stored in such a way that the arrows always point upwards. Rolling, swinging, severe tipping or tumbling or other such handling must be avoided. |
| Keep away from heat (solar radiation) |  | Compliance with the symbol is best achieved if the cargo is kept under the coolest possible conditions. In any event, it must be kept away from additional sources of heat. It may be appropriate to enquire whether prevailing or anticipated temperatures may be harmful. |
| Protect from heat and radioactive sources |  | Stowage as for the preceding symbol. The cargo must additionally be protected from radioactivity. |
| Sling here |  | The symbol indicates merely where the cargo should be slung, but not the method of lifting. If the symbols are applied equidistant from the middle or center of gravity, the package will hang level if the slings are of identical length. If this is not the case, the slinging equipment must be shortened on one side. |
| Keep dry |  | Cargo bearing this symbol must be protected from excessive humidity and must accordingly be stored under cover. If particularly large or bulky packages cannot be stored in warehouses or sheds, they must be carefully covered with tarpaulins. |

| | | | |
|---|--|--------------------------------------|-----------------|
|  | TITLE | SPECIFICATION NO. PE-TS-888-100-A001 | |
| | TECHNICAL SPECIFICATION FOR SEAWORTHY PACKING FOR EXPORT JOBS | VOLUME II B | |
| | | SECTION D | |
| | | REV. NO. 0 | DATE 10/08/2010 |
| | | SHEET 24 | OF 52 |

| | | |
|--------------------------------|---|--|
| Center of gravity |  | <p>This symbol is intended to provide a clear indication of the position of the center of gravity. To be meaningful, this symbol should only be used where the center of gravity is not central. The meaning is unambiguous if the symbol is applied onto two upright surfaces at right angles to each other.</p> |
| No hand truck here |  | <p>The absence of this symbol on packages amounts to permission to use a hand truck on them.</p> |
| Stacking limitation |  | <p>The maximum stacking load must be stated as "... kg max.". Since such marking is sensible only on packages with little loading capacity, cargo bearing this symbol should be stowed in the uppermost layer.</p> |
| Clamp here |  | <p>Stating that the package may be clamped at the indicated point is logically equivalent to a prohibition of clamping anywhere else.</p> |
| Temperature limitations |  | <p>According to regulations, the symbol should either be provided with the suffix "...°C" for a specific temperature or, in the case of a temperature range, with an upper ("...°C max.") and lower ("...°C min.") temperature limit. The corresponding temperatures or temperature limits should also be noted on the consignment note.</p> |
| Do not use forklift truck here |  | <p>This symbol should only be applied to the sides where the forklift truck cannot be used. Absence of the symbol on other sides of the package amounts to permission to use forklift trucks on these sides.</p> |
| Electrostatic sensitive device |  | <p>Contact with packages bearing this symbol should be avoided at low levels of relative humidity, especially if insulating footwear is being worn or the ground/floor is nonconductive. Low levels of relative humidity must in particular be expected on hot, dry summer days and very cold winter days.</p> |

| | | | |
|---|--|--------------------------------------|-----------------|
|  | TITLE TECHNICAL SPECIFICATION FOR SEAWORTHY PACKING FOR EXPORT JOBS | SPECIFICATION NO. PE-TS-888-100-A001 | |
| | | VOLUME II B | |
| | | SECTION D | |
| | | REV. NO. 0 | DATE 10/08/2010 |
| | | SHEET 25 | OF 52 |



| | | |
|------------------------|---|--|
| Do not destroy barrier |  | <p>A barrier layer which is (virtually) impermeable to water vapor and contains desiccants for corrosion protection is located beneath the outer packaging. This protection will be ineffective if the barrier layer is damaged. Since the symbol has not yet been approved by the ISO, puncturing of the outer shell must in particular be avoided for any packages bearing the words "Packed with desiccants".</p> |
| Tear off here |  | <p>This symbol is intended only for the receiver.</p> |

FIG-12

| | | | |
|---|--|--------------------------------------|-----------------|
|  | TITLE | SPECIFICATION NO. PE-TS-888-100-A001 | |
| | TECHNICAL SPECIFICATION FOR SEAWORTHY PACKING FOR EXPORT JOBS | VOLUME II B | |
| | | SECTION D | |
| | | REV. NO. 0 | DATE 10/08/2010 |
| SHEET 26 | | OF 52 | |



| | | | | | |
|---|--|----------------------|----------------|--|------------------|
|  | | BHEL-PEM-DELHI-INDIA | | | |
| CONSIGNEE | | | | | |
| MATERIAL | | | | | |
| CUSTOMER REF. | | | MD. NO. | | |
| DESPATCH ADVICE NOTE NO. | | | CASE NO. | | |
| DIMENSIONS(MM) LXBXH | | | NET WT -KGS | | GROSS WT -KGS |
| | HANDLE WITH CARE -- KEEP DRY DO NOT DROP -- DO NOT TILT | | | | |
| SPECIAL INSTRUCTIONS | | | | | |

FIG-13: MARKING PLATE

| | | |
|---|--|--------------------------------------|
|  | TITLE | SPECIFICATION NO. PE-TS-888-100-A001 |
| | TECHNICAL SPECIFICATION FOR SEAWORTHY PACKING FOR EXPORT JOBS | VOLUME II B |
| | | SECTION D |
| | | REV. NO. 0 DATE 10/08/2010 |
| | | SHEET 27 OF 52 |

THIS IS A PART OF TECHNICAL SPECIFICATION PE-TS-372-673-A001

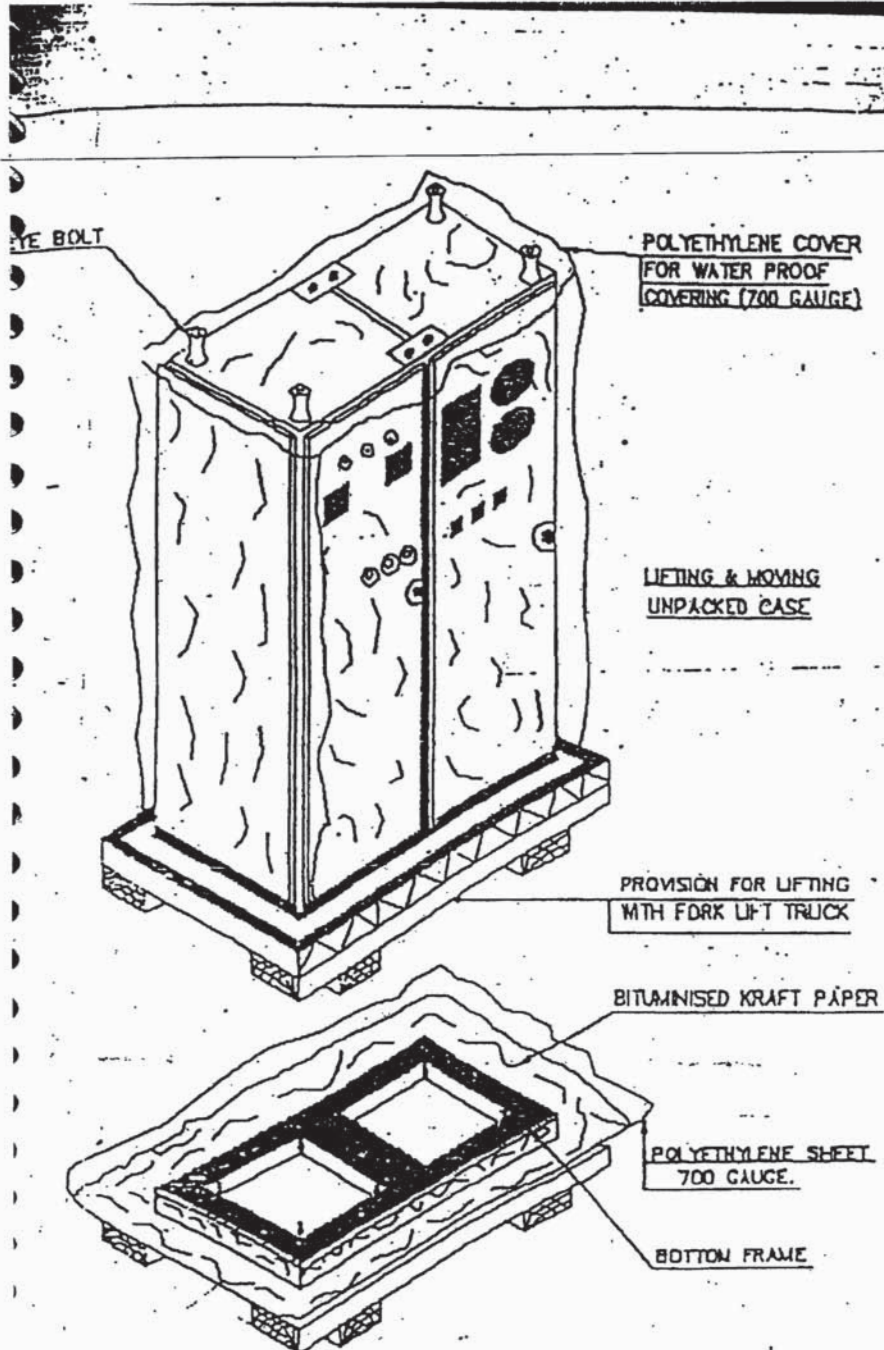



FIGURE-14

| | | | | |
|---|---|--------------------------------------|-----------------|----|
|  | TITLE | SPECIFICATION NO. PE-TS-888-100-A001 | | |
| | TECHNICAL SPECIFICATION FOR SEAWORTHY PACKING FOR EXPORT JOBS | VOLUME II B | | |
| | | SECTION D | | |
| | | REV. NO. 0 | DATE 10/08/2010 | |
| | | SHEET 28 | OF | 52 |

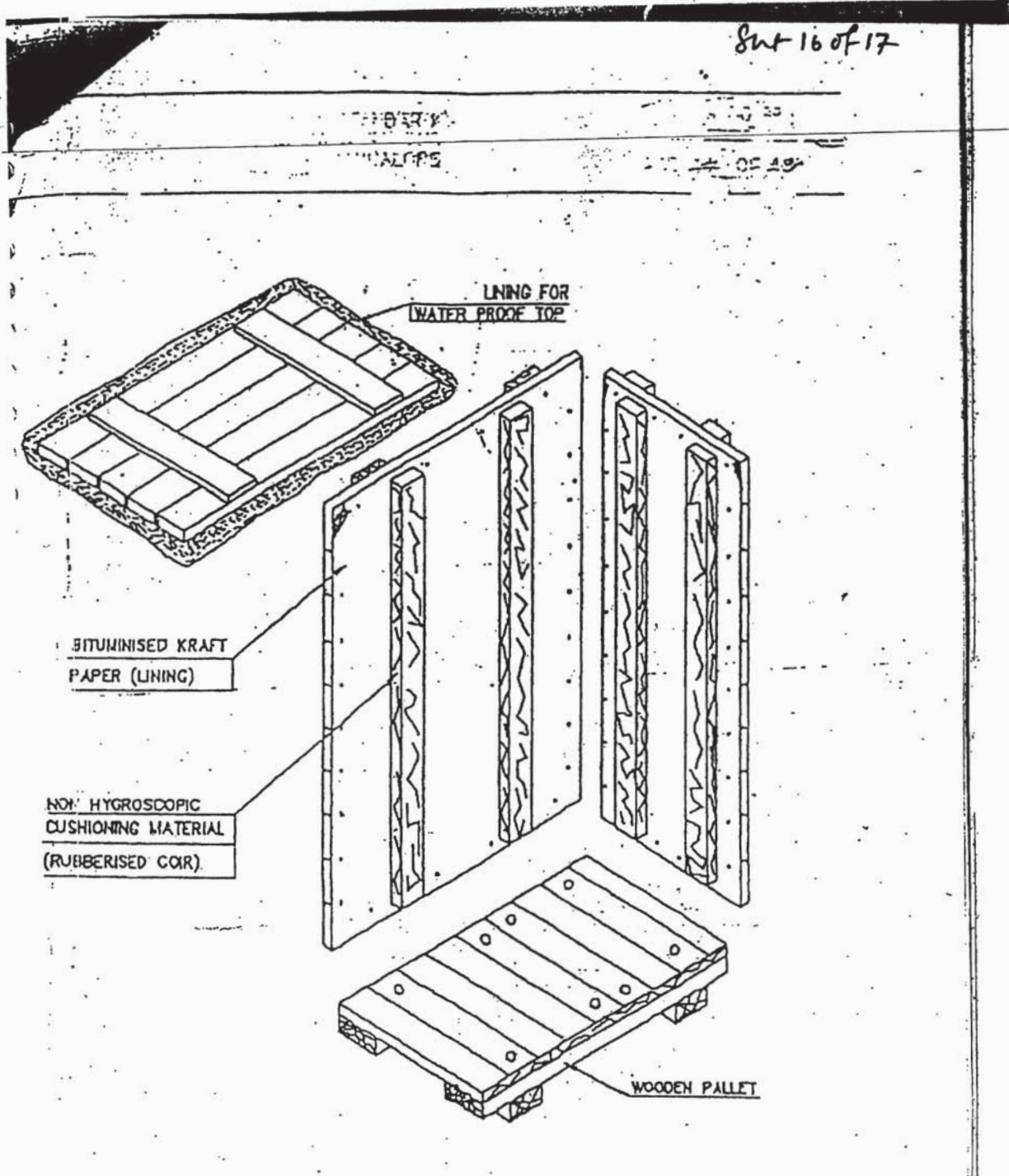



FIGURE-15

| | | | |
|---|--|--------------------------------------|-----------------|
|  | TITLE | SPECIFICATION NO. PE-TS-888-100-A001 | |
| | TECHNICAL SPECIFICATION FOR SEAWORTHY PACKING FOR EXPORT JOBS | VOLUME II B | |
| | | SECTION D | |
| | | REV. NO. 0 | DATE 10/08/2010 |
| | | SHEET 29 | OF 52 |

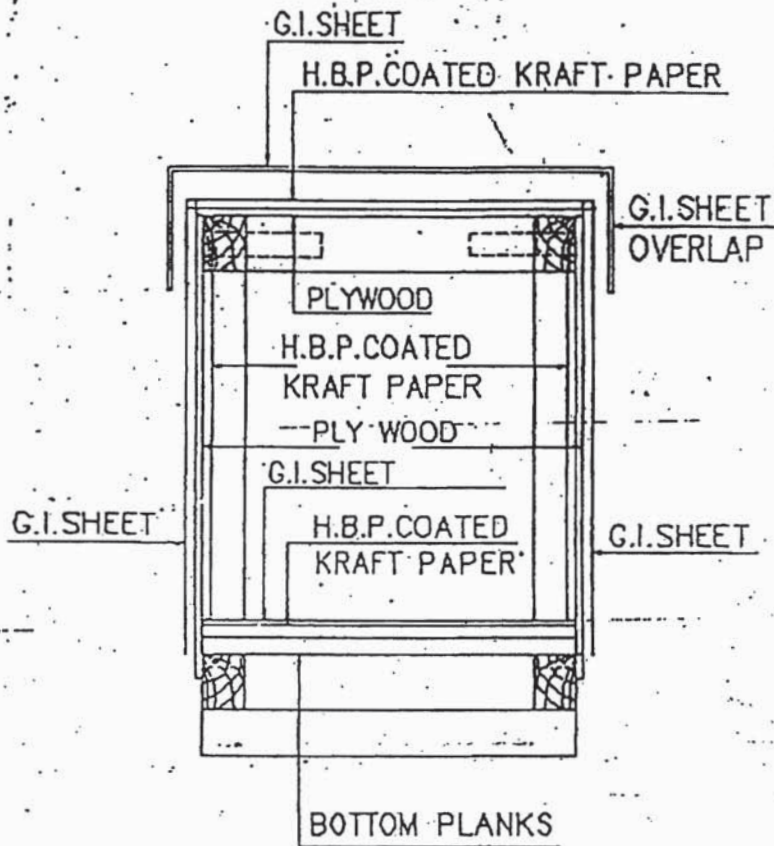



FIG-16 : CLOSED PACKING CASE WITH G.I.SHEET
SHOWING LAYERS OF PACKING MATERIALS.

| | | | |
|---|--|--------------------------------------|-----------------|
|  | TITLE | SPECIFICATION NO. PE-TS-888-100-A001 | |
| | TECHNICAL SPECIFICATION FOR SEAWORTHY PACKING FOR EXPORT JOBS | VOLUME II B | |
| | | SECTION D | |
| | | REV. NO. 0 | DATE 10/08/2010 |
| | | SHEET 30 | OF 52 |

10.0 TYPICAL PACKING DETAILS/PROCEDURE FOR MECHANICAL ITEMS

10.1 INSULATION MATERIAL (MINERAL WOOL MATTRESSES)

This specification covers the requirements of seaworthy packing and marking for bonded mineral (rock) wool mattresses having metallic hexagonal wire netting as facing on one or both sides.

10.1.1 TYPE OF CONSTRUCTION

Mattress shall be packed in Polythene (of 0.2 mm thickness) all around and sealed to prevent moisture absorption during transit and storage. Further it shall be wrapped with Bitumen coated Polythene bonded/lined Hessian and stitched and then packed in 5 ply DFC carton box.

Silica gel is used for this purpose to protect contents over sufficiently long time from corrosion. Silica gel shall be of indicating type conforming to IS:304-1979 packed in cotton bags placed at different positions inside the packing for absorbing moisture and shall not come into direct contact with the material inside the package. The quantity of silica gel shall be enough for storage period of one year. However, it shall not be less than 4 gms per litre volume of case subject to minimum of 400 gms per case.

Each mattress as well as the packages shall be serial numbered. Also, printed sheets indicating the nominal thickness, density and wire netting details (i.e. material and size) shall be placed below the wire netting.

Following details shall be legibly written on the packages. The details shall also be typed on a sheet of paper & kept in a sealed Polythene cover, inside the packages

- a) Project Name
- b) Purchase Order No.
- c) Sl. No. of package
- d) Size of mattress (Thickness x Length x Width)
- e) Density
- f) Wire netting material and size
- g) Weight of the package

10.2 INSULATION MATERIAL (ALUMINIUM COIL)

Heavy Gauge Aluminium Coil Packaging are done by Eye-to-Sky packaging or by Eye to eye packaging as per the proven practice being followed by manufacturer of Aluminium sheets.

10.2.1 Type of construction for Eye to Sky packaging

- a. Strapping of coil with polyester strap around circumference at one place.
- b. Putting paper I. D. Edge protector.
- c. Wrapping the coil with VCI stretch film after putting silica gel bags (4 nos.) Inside the coil.
- d. Wrapping the coil with HDPE film.
- e. Covering the coil including its build up & bore with masonite / particle board.
- f. Putting metallic I. D on coil.
- g. Putting O.D edge protector (paper) on coil.

| | | | |
|---|--|--------------------------------------|-----------------|
|  | TITLE | SPECIFICATION NO. PE-TS-888-100-A001 | |
| | TECHNICAL SPECIFICATION FOR SEAWORTHY PACKING FOR EXPORT JOBS | VOLUME II B | |
| | | SECTION D | |
| | | REV. NO. 0 | DATE 10/08/2010 |
| | | SHEET 31 | OF 52 |

- h. Putting circumferential polyester strap (3 nos.) & eye polyester strap (4 nos.).
- i. After placing the coil on coil tilter ply wood (10mm thick) of suitable size along with wooden pallet is to be put at the bottom side of the coil.
- j. Coil is to be tilted to eye-to-sky position.
- k. Final strapping with metallic strap to unit coil and skid at 2 places with top cover of plywood.
- l. Fixing the coil with wooden blocks at 4 corners.
- m. Labeling 2 nos.(one metallic & one adhesivetype) For specification, net wt. & gross wt.

10.2.2 Type of construction for Eye to Eye packaging

- a. Strapping of coil with polyester strap around circumference at one place.
 - b. Putting paper I. D. Edge protector.
 - c. Wrapping the coil with VCI stretch film after putting silica gel bags (4 nos.) Inside the coil.
 - d. Wrapping the coil with HDPE film.
 - e. Covering the coil including its build up & bore with masonite / particle board.
 - f. Putting metallic I. D on coil.
 - g. Putting O.D edge protector (paper) on coil.
 - h. Putting circumferential polyester strap (3 nos.) & eye polyester strap (4 nos.).
 - i. Placing of coil on wooden skid Coil is to be tilted to eye-to-sky position.
 - j. Final strapping of coil and skid at 2 places with steel strap. Fixing the coil with wooden blocks at 4 corners.
- Labeling 2 nos.(one metallic & one adhesive type) For specification net wt. & gross wt.

10.3 Packing Procedure for Online Tube Cleaning System and accessories

This procedure is applicable for the shipment of Onload Tube Cleaning System and accessories by sea.

10.3.1 Packing details:

- The Packing case shall be made of treated rubber wood. The design of the case shall be as per Annexure IIIA & IIIB.
- The Equipments shall be placed on the wooden base of the Packing case and fastened if required to arrest the movement of the same.
- Equipment shall be covered by Polythene sheet and inside wall surfaces of the wooden cases also shall be covered by polythene sheet.
- All Nozzles shall be closed with plywood dummies.
- All electrical components assembled or loose shall be covered with polythene sheets along with silica gel pack.
- Silica gel desiccants shall be kept inside each case in sufficient quantities in order to absorb the moisture.

| | | | |
|---|--|---|-----------------|
|  | TITLE | SPECIFICATION NO. PE-TS-888-100-A001 | |
| | TECHNICAL SPECIFICATION FOR SEAWORTHY PACKING FOR EXPORT JOBS | VOLUME II B | |
| | | SECTION D | |
| | | REV. NO. 0 | DATE 10/08/2010 |
| | | SHEET 32 | OF 52 |

- Thermocol packing shall be made for glass items like Ball vessel sight glass, Vpiece sight glass & pressure gauge.
- Silica gel desiccants shall be kept inside of each case to absorb the moisture.
- A Packing list covered in a polythene envelope shall be fixed inside and outside of each packing case.
- Shipping marks and consignee address shall be painted on the outer surface of the case.
- All handling instruction required for the case like top, sling, rain, handle with care etc, shall be marked on the case as per the symbol attached.
- Machined surface will be applied with Anti rust oil and covered by polyurethane sheet to protect from external oxidation.
- All valves will be closed with dummies to protect the internals and placed in the wooden case which will covered by polyurethane sheet.

| | | | |
|---|--|--------------------------------------|-----------------|
|  | TITLE | SPECIFICATION NO. PE-TS-888-100-A001 | |
| | TECHNICAL SPECIFICATION FOR SEAWORTHY PACKING FOR EXPORT JOBS | VOLUME II B | |
| | | SECTION D | |
| | | REV. NO. 0 | DATE 10/08/2010 |
| | | SHEET 33 | OF 52 |

This Type of case to be used for following items:

1. BALL SEPERATOR
2. BALL COLECTOR SKID

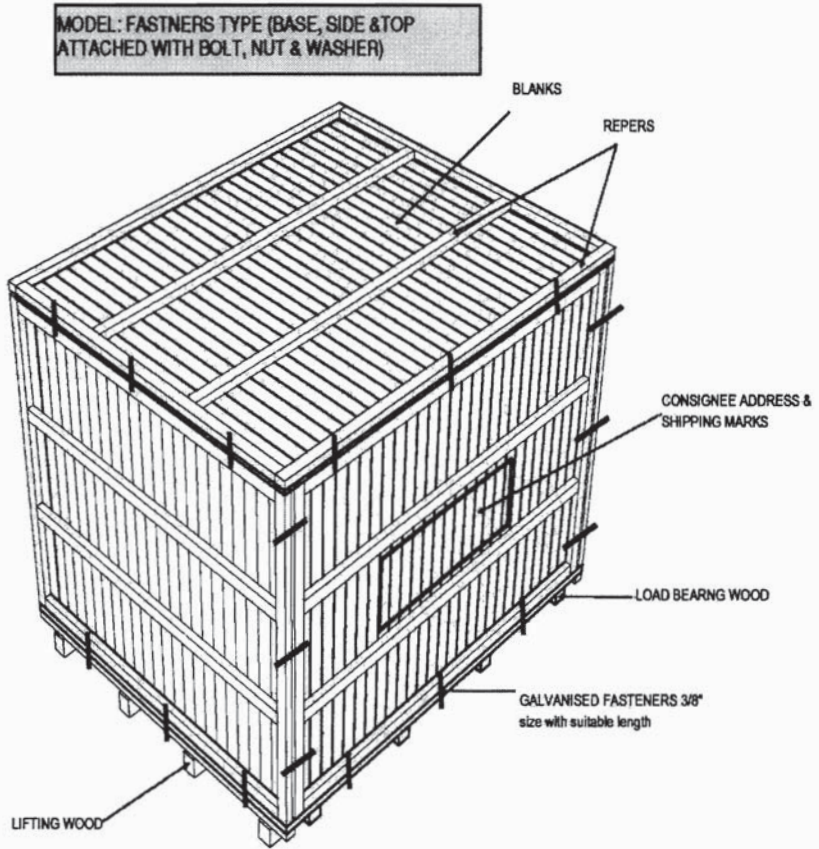

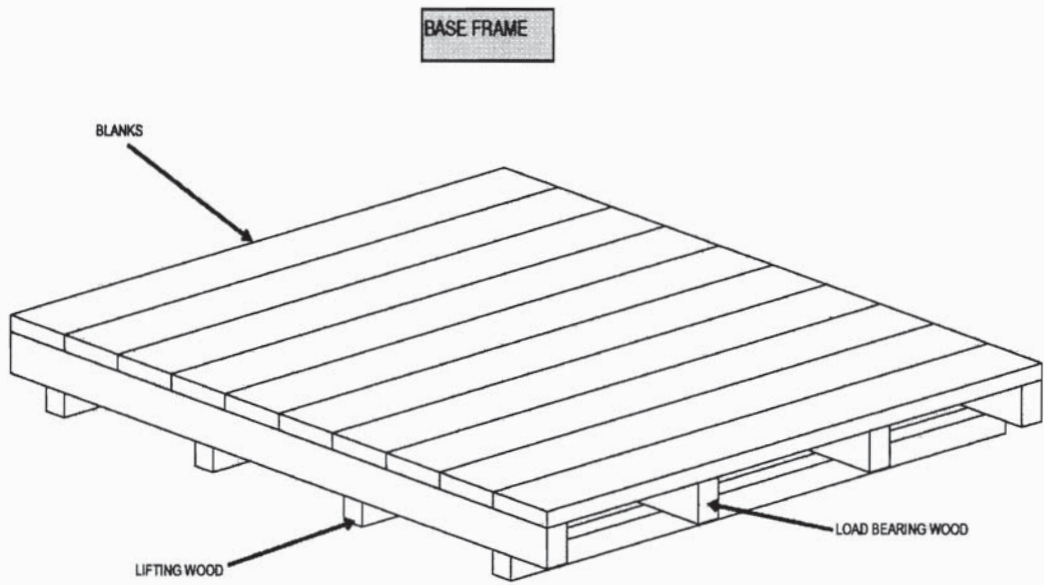

| | | | |
|---|--|---|-----------------|
|  | TITLE TECHNICAL SPECIFICATION FOR SEAWORTHY PACKING FOR EXPORT JOBS | SPECIFICATION NO. PE-TS-888-100-A001 | |
| | | VOLUME II B | |
| | | SECTION D | |
| | | REV. NO. 0 | DATE 10/08/2010 |
| | | SHEET 34 | OF 52 |



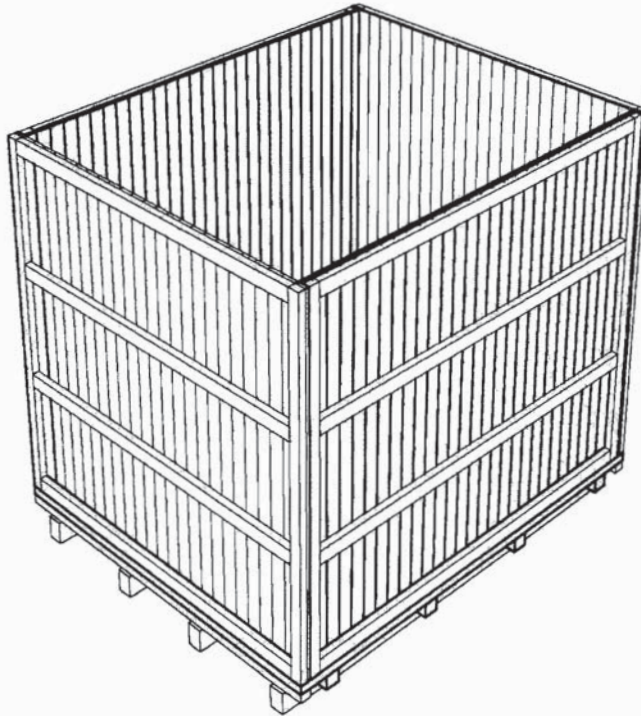

| | | | |
|---|--|---|-----------------|
|  | TITLE TECHNICAL SPECIFICATION FOR SEAWORTHY PACKING FOR EXPORT JOBS | SPECIFICATION NO. PE-TS-888-100-A001 | |
| | | VOLUME II B | |
| | | SECTION D | |
| | | REV. NO. 0 | DATE 10/08/2010 |
| | | SHEET 35 | OF 52 |

MODEL: FASTNERS TYPE - WITHOUT TOP

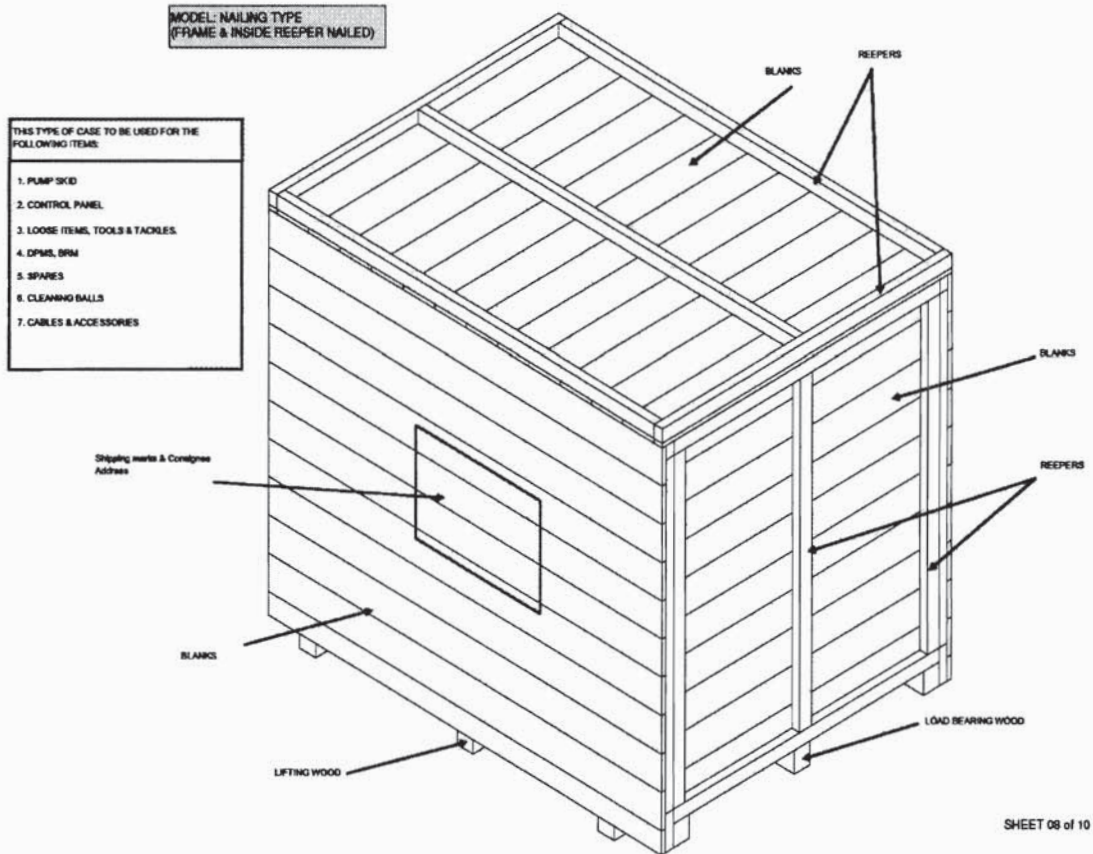

| | | | |
|---|--|--------------------------------------|-----------------|
|  | TITLE | SPECIFICATION NO. PE-TS-888-100-A001 | |
| | TECHNICAL SPECIFICATION FOR SEAWORTHY PACKING FOR EXPORT JOBS | VOLUME II B | |
| | | SECTION D | |
| | | REV. NO. 0 | DATE 10/08/2010 |
| | | SHEET 36 | OF 52 |



| | | | |
|---|--|---|-----------------|
|  | TITLE TECHNICAL SPECIFICATION FOR SEAWORTHY PACKING FOR EXPORT JOBS | SPECIFICATION NO. PE-TS-888-100-A001 | |
| | | VOLUME II B | |
| | | SECTION D | |
| | | REV. NO. 0 | DATE 10/08/2010 |
| | | SHEET 37 | OF 52 |

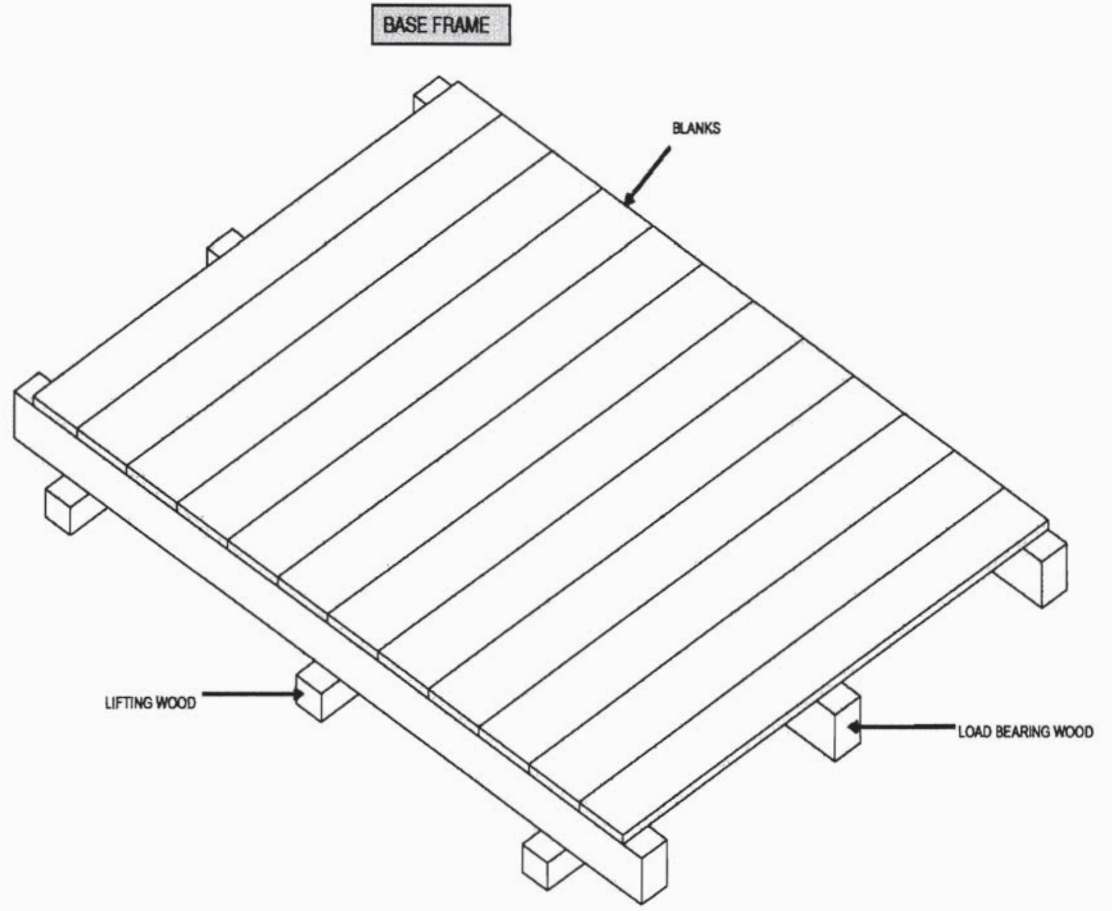

SHEET 09 of 10

| | | | | |
|---|--|---|-----------------|----|
|  | TITLE | SPECIFICATION NO. PE-TS-888-100-A001 | | |
| | TECHNICAL SPECIFICATION FOR SEAWORTHY PACKING FOR EXPORT JOBS | VOLUME II B | | |
| | | SECTION D | | |
| | | REV. NO. 0 | DATE 10/08/2010 | |
| | | SHEET 38 | OF | 52 |

NAILING TYPE MODEL WITH TOP OPEN

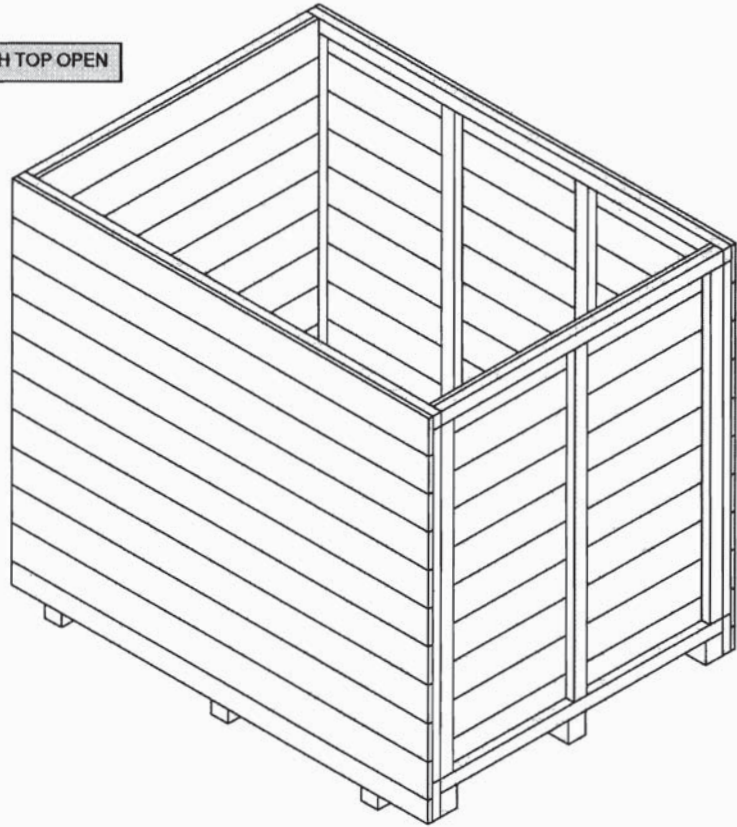

SHEET 10 of 10

| | | | |
|---|--|--------------------------------------|-----------------|
|  | TITLE | SPECIFICATION NO. PE-TS-888-100-A001 | |
| | TECHNICAL SPECIFICATION FOR SEAWORTHY PACKING FOR EXPORT JOBS | VOLUME II B | |
| | | SECTION D | |
| | | REV. NO. 0 | DATE 10/08/2010 |
| | | SHEET 39 | OF 52 |

10.4 PACKING OF LOOSE ITEMS

Resin, filter media and Membranes are also included in this category

Loose mechanical, electrical and C&I items e.g. valves, fittings, pressure/temperature gauges/switches, circuit breakers, relays etc shall be individually wrapped using polyethylene sheets/U foam/ thermocol sheets/air bubble sheets depending upon the items and then packed in wooden boxes. The left out spaces and top of the boxes shall be filled with rubberized coir to get proper cushioning effect, Special attention shall be paid to relays, instruments etc for arresting the movements of their operating mechanism during transportation.

The construction of wooden packing cases shall be as per clause 9.3.1 retaining its all features concerning strength of the box. The construction of wooden packing case for electrical and C&I items shall be as per fig-16.

Inner surface of 6 sides of the box shall be lined with bitumen coated hessian polyethylene kraft paper. Rubberized coir of min. 25mm thickness and 100 mm width shall be nailed to inner surfaces of bottom and 4 sides of the boxes.

11.0 PACKING OF ELECTRICAL ITEMS

11.1 CABLES

11.1.1 Type of Equipment
All type of cables..

11.1.2 Type of Construction

New or practically new cable drums made of steel and painted with epoxy resin paint are to be used. Cable ends are carefully protected before packing. Over the cables polyethylene sheet shall be wrapped and then sealed properly. Cable drum can be put in wooden crates for ease in transportation and handling. (Wooden cable drum is also acceptable, however vendor to furnish constructional details for approval).

| | | | |
|---|--|--------------------------------------|-----------------|
|  | TITLE TECHNICAL SPECIFICATION FOR SEAWORTHY PACKING FOR EXPORT JOBS | SPECIFICATION NO. PE-TS-888-100-A001 | |
| | | VOLUME II B | |
| | | SECTION D | |
| | | REV. NO. 0 | DATE 10/08/2010 |
| | | SHEET 40 | OF 52 |

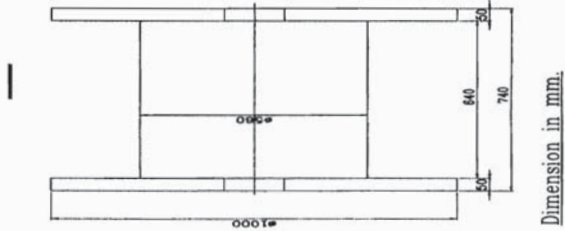
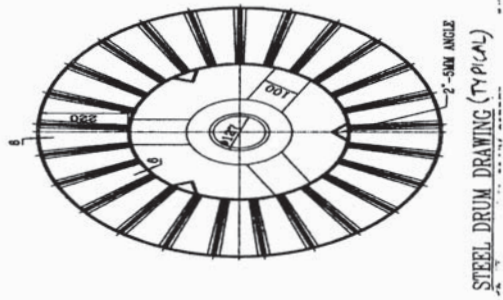

| | | | |
|---|--|--------------------------------------|-----------------|
|  | TITLE | SPECIFICATION NO. PE-TS-888-100-A001 | |
| | TECHNICAL SPECIFICATION FOR SEAWORTHY PACKING FOR EXPORT JOBS | VOLUME II B | |
| | | SECTION D | |
| | | REV. NO. 0 | DATE 10/08/2010 |
| | | SHEET 41 | OF 52 |

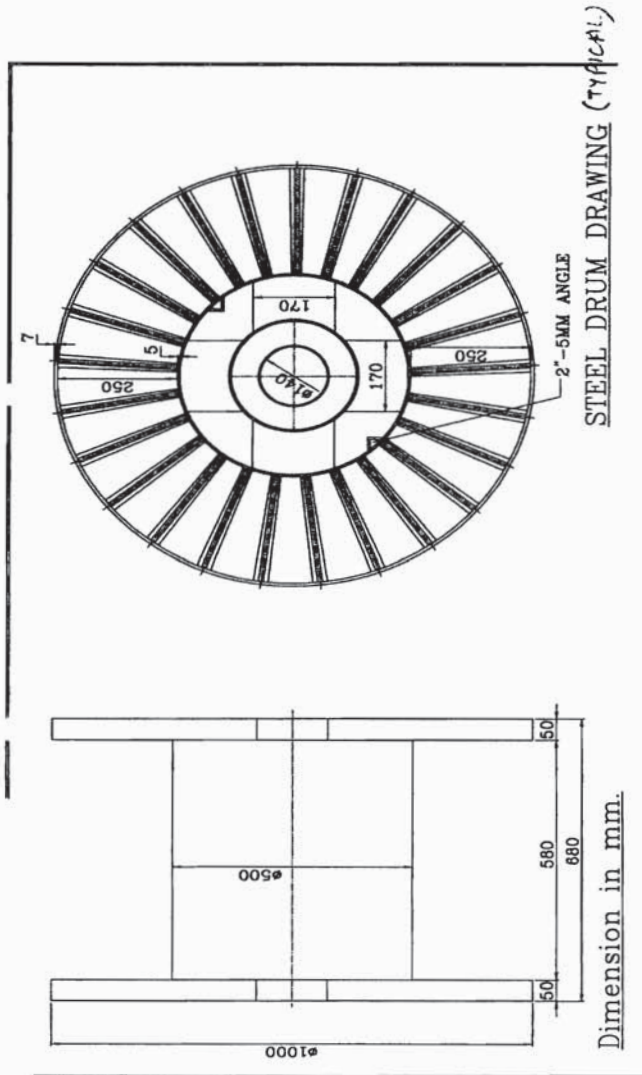

11.2 PACKING OF CABLE TRAYS & ACCESSORIES AND CABLE TRAY SUPPORT MATERIAL

11.2.1 Cable trays can be packed in wooden boxes as per fig 1 to 11 or in steel boxes. Details of steel box construction is as indicated below.

- 1) All Dimensions are in "mm" unless otherwise stated.
- 2) Packing Box shall be fabricated using 50x50x6mm MS Angle, 50x3mm Flat, 2.5 mm thick C Channel, 1mm & 1.6mm Thick sheet.
- 3) Finish of Packing Box Shall be Galvanized.
- 4) Angle & Channel Section forming part of the Main frame shall be welded thoroughly with each other to give a rigid structure.
- 5) Sheet Section and Flat section shall be bolted/ Riveted/ Welded suitably to the Main frame stated in '4' above.

| | | | |
|---|--|---|-----------------|
|  | TITLE | SPECIFICATION NO. PE-TS-888-100-A001 | |
| | TECHNICAL SPECIFICATION FOR SEAWORTHY PACKING FOR EXPORT JOBS | VOLUME II B | |
| | | SECTION D | |
| | | REV. NO. 0 | DATE 10/08/2010 |
| | | SHEET 42 | OF 52 |

- 6) Welding Portion on galvanized surfaces shall be painted with Zinc Rich Paint.
- 7) Dispatch details such as consignor/consignee address, contract and case details, 'country of origin, port of delivery, stacking instructions shall be written on one of the side of boxes. An anodized aluminium plate as per details and specifications given in page 3 of 5 shall be provided on the boxes
- 8) One copy of packing slip wrapped in polythylene bag covered with suitable aluminium .packing slip holder to be nailed on the external surface of the box. One more copy 9f the packing Slip wrapped in polythylene bag to be kept inside the box at the prominent place.
- 9) **INDICATION MARKS ON THE BOXES:** Markings shall be provided on the boxes indicating position of Boxes for handling, storage and nature of consignment. For guidelines referred page 4 of 5. The ink issued for this purpose as well as for marking dispatch instruction shall be indelible/non-washable marking ink.
- 10) Each item as mentioned in BOQ shall be packed & supplied as a set comprising of required numbers of associated fasteners & hardware etc

| | | | |
|---|--|--------------------------------------|-----------------|
|  | TITLE | SPECIFICATION NO. PE-TS-888-100-A001 | |
| | TECHNICAL SPECIFICATION FOR SEAWORTHY PACKING FOR EXPORT JOBS | VOLUME II B | |
| | | SECTION D | |
| | | REV. NO. 0 | DATE 10/08/2010 |
| | | SHEET 43 | OF 52 |

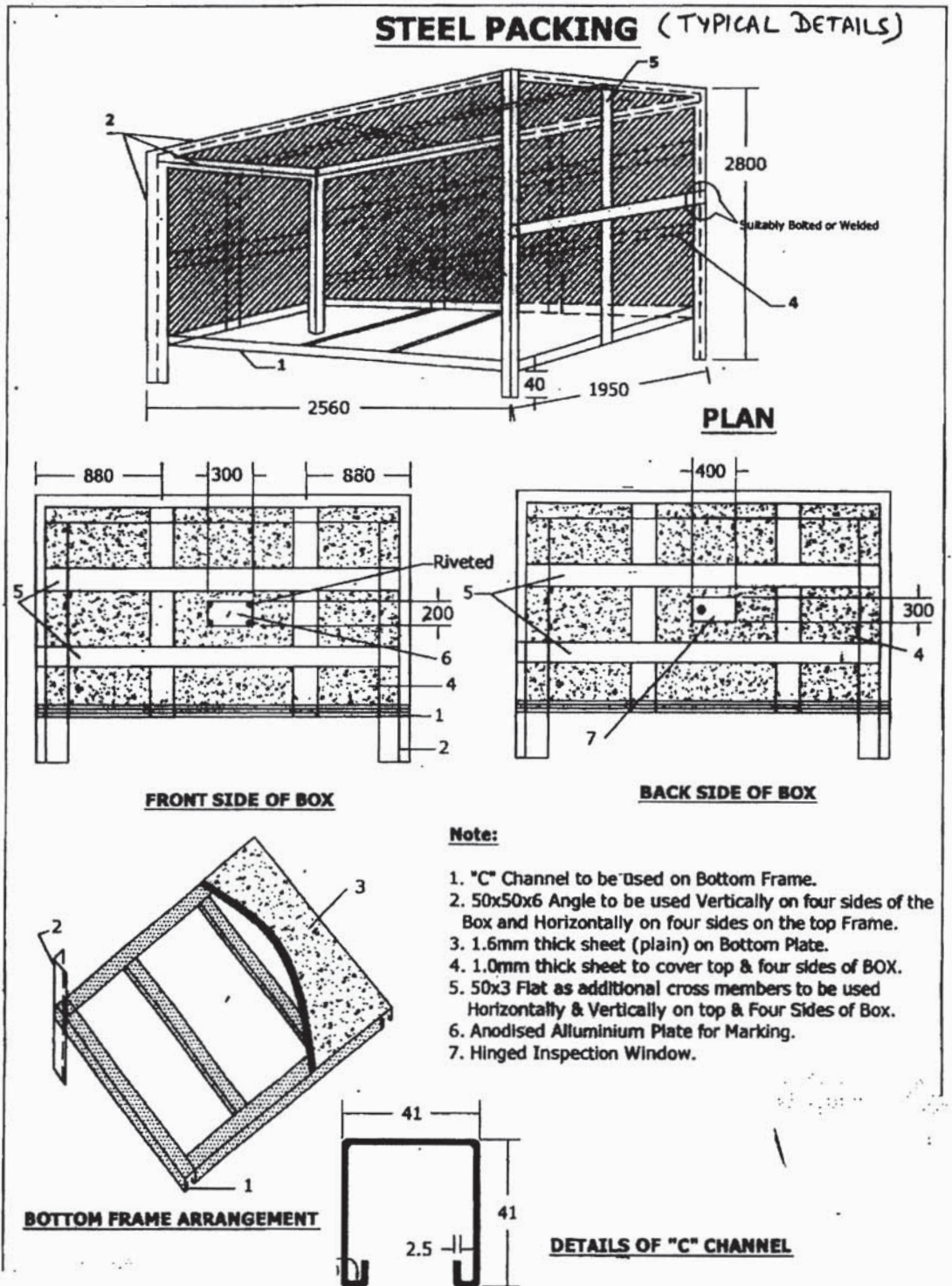

| | | | |
|---|--|--------------------------------------|-----------------|
|  | TITLE | SPECIFICATION NO. PE-TS-888-100-A001 | |
| | TECHNICAL SPECIFICATION FOR SEAWORTHY PACKING FOR EXPORT JOBS | VOLUME II B | |
| | | SECTION D | |
| | | REV. NO. 0 | DATE 10/08/2010 |
| | | SHEET 44 | OF 52 |

11.3 PACKING FOR STATION LIGHTING SYSTEM

Aspects of packing specific to equipments / items of station lighting system are given here. All other instructions / aspects as per the main specification of export packing which are not covered here shall also be applicable.

11.3.1 For LIGHTING TRANSFORMER, DISTRIBUTION BOARDS, LIGHTING PANELS,

- a) Construction of packing case for LIGHTING DIATRIBUTION BOARDS, LIGHTING PANELS, TRANSFORMER . shall be EITHER as per FIGURE 1,2,3,5,6,7,8,9,10,11 OR FIGURE 14,15,16.
- b) Each Panel/Transformer shall be individually covered with double polythene sheet of thickness 175 microns minimum.
- c) All the 6 inner surfaces of packing shall be nailed with bitumen coated hessian polythene craft paper. Wherever 2 pieces of craft paper are used, the joint shall have minimum overlap of 20mm.

For the top frame it shall be project on all sides by 100mm and shall be nailed on sides .

- d) The gap between the panels and packing case shall be filled with rubberized coir of thickness 50mm minimum and width 100mm. The distance between two consecutive supports of rubberized coir shall be less than 500mm.
- e) Silica get packed in cotton bags shall be placed at different positions inside the packing.
- f) Packing case shall be finally covered with GI sheet of thickness 0.4mm minimum.

11.3.2 For LUMINARIES, RECEPTACLES. EMERGENCY LIGHT, 240/24V TRANSFORMER, CEILING FAN, SWITCH BOARDS, FLEXIBLE CONDUIT, WIRES, EARTH WIRE. JUNCTION BOXES, ERECTION COMMISSIONING SPARES, RECOMMENDED SPARES , ERECTION MATERIAL AND CONSUMBALES

- a) Construction of packing case for THE ABOVE MATERIAL shall be as per FIGURE 1to11.
- b) Items placed inside the case shall be covered with double polythene sheet of thickness 175 microns minimum.
- c) All the 6 inner surfaces of packing shall be nailed with bitumen coated hessian craft paper. wherever 2 pieces of craft paper are used, the joint shall have minimum overlap of 20mm. For the top frame it shall be project on all sides by 100mm and shall be nailed on sides.
- d) Silica get packed in cotton bags shall be placed at different positions inside the packing.

11.3.3 For CONDUIT PIPE

As per international practice pipes are shipped in open bundles with metal strapping. Packing as per attached figure A shall be provided which is described as following:

- a) Each bundle shall be wrapped with 2 layers of 175 microns thick polythene sheet.
- b) Then bundle will be wrapped with bitumen coated hessian craft paper.
- c) Bundle shall be strapped with steel straps.
- d) An anodized aluminium packing description plate as per Figure No. 13 shall be provided.

11.3.4 For POLES

Poles will be wrapped with 2 layers of minimum 175 microns thick polythene sheet and then with bitumen coated hessian craft paper, packed as per Figure – C i.e. bundling.

11.3.5 For STRUCTURAL STEEL

| | | | |
|---|--|---|-----------------|
|  | TITLE TECHNICAL SPECIFICATION FOR SEAWORTHY PACKING FOR EXPORT JOBS | SPECIFICATION NO. PE-TS-888-100-A001 | |
| | | VOLUME II B | |
| | | SECTION D | |
| | | REV. NO. 0 | DATE 10/08/2010 |
| | | SHEET 45 | OF 52 |

Structural steel will be different sizes and shapes. Hence it will be packed as per Figure No. B and described as following :

- a) Each bundle shall be wrapped with 2 layers of 175 microns thick polythene sheet.
- b) Then bundle will be wrapped with bitumen coated hessian craft paper.
- c) Bundle shall be strapped with steel straps.
- d) An anodized aluminium packing description plate as per Figure No. 13 shall be provided.

| | | | |
|---|--|--------------------------------------|-----------------|
|  | TITLE | SPECIFICATION NO. PE-TS-888-100-A001 | |
| | TECHNICAL SPECIFICATION FOR SEAWORTHY PACKING FOR EXPORT JOBS | VOLUME II B | |
| | | SECTION D | |
| | | REV. NO. 0 | DATE 10/08/2010 |
| | | SHEET 46 | OF 52 |

PACKING PROCEDURE FOR CONDUIT PIPE

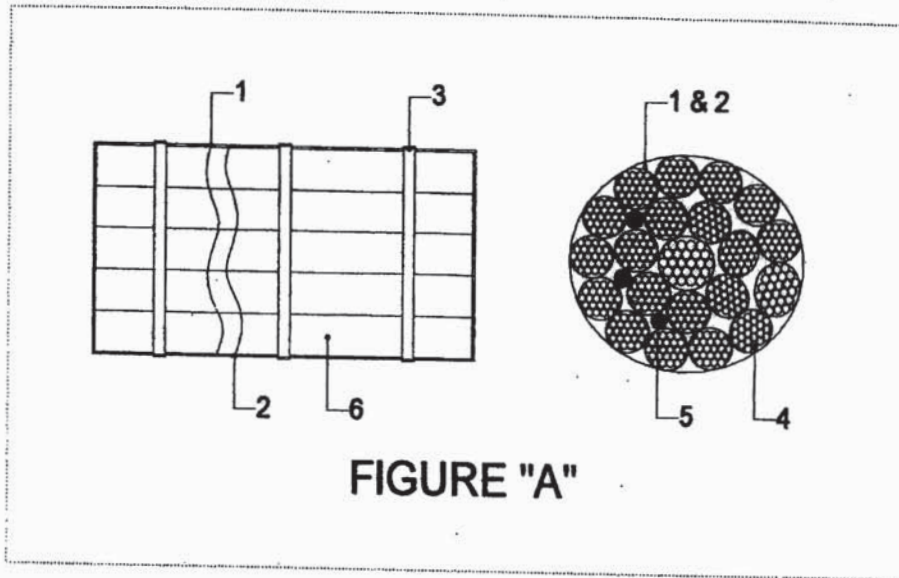



FIGURE "A"

- 1) LAYER OF BITUMEN COATED HESSIAN KRAFT PAPER.
- 2) LAYER OF POLYTHENE SHEET.
- 3) METAL STRAPPING.
- 4) CONDUIT PIPES.
- 5) SILICA GEL POUCHES.
- 6) BUNDLES OF CONDUIT PIPES.

| | | | |
|---|---|--------------------------------------|-----------------|
|  | TITLE | SPECIFICATION NO. PE-TS-888-100-A001 | |
| | TECHNICAL SPECIFICATION FOR SEAWORTHY PACKING FOR EXPORT JOBS | VOLUME II B | |
| | | SECTION D | |
| | | REV. NO. 0 | DATE 10/08/2010 |
| | | SHEET 47 | OF 52 |

PACKING PROCEDURE FOR STRUCTURAL STEEL

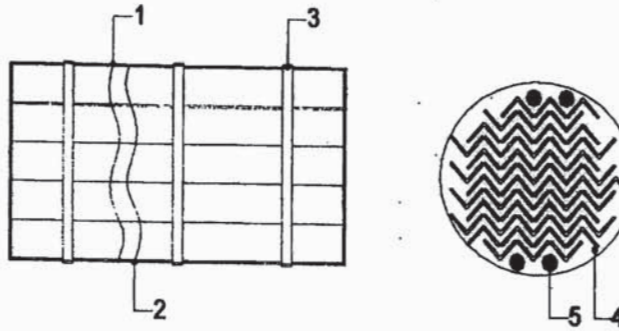

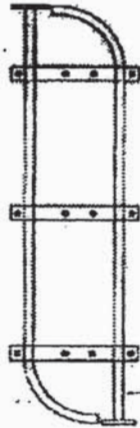

FIGURE "B"

- 1) LAYER OF BITUMEN COATED HESSIAN KRAFT PAPER.
- 2) LAYER OF POLYTHENE SHEET.
- 3) METAL STRAPPING.
- 4) STRUCTURAL STEEL.
- 5) SILICA GEL POUCHES.

| | | |
|---|--|--------------------------------------|
|  | TITLE | SPECIFICATION NO. PE-TS-888-100-A001 |
| | TECHNICAL SPECIFICATION FOR SEAWORTHY PACKING FOR EXPORT JOBS | VOLUME II B |
| | | SECTION D |
| | | REV. NO. 0 DATE 10/08/2010 |
| | | SHEET 48 OF 52 |

packing procedure for poles



POLES WRAPPED WITH POLYETHENE SHEET & EXTINGUISHER COATED HESSIAN CLOTH



TOP WOODEN BATTEN TO BE FIXED WITH L8x80x8 MM ON TOP OF IT. FOR TIEDING THE ROD 25 MM DIA



BOTTOM WOODEN BATTEN TO BE FIXED ON L8x80x8 MM ANGLE

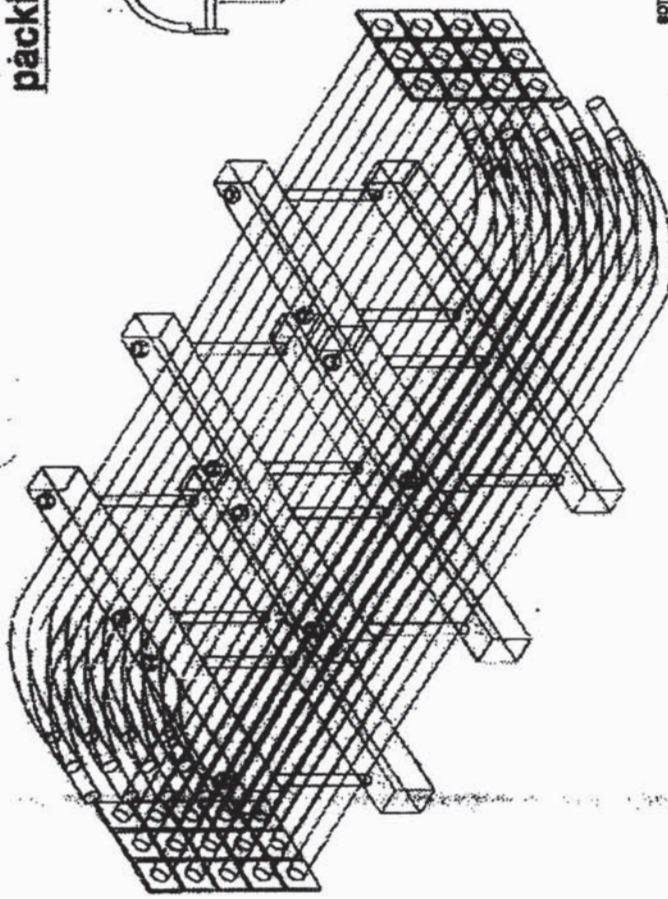



FIGURE "C"

| | | | |
|---|--|--------------------------------------|-----------------|
|  | TITLE | SPECIFICATION NO. PE-TS-888-100-A001 | |
| | TECHNICAL SPECIFICATION FOR SEAWORTHY PACKING FOR EXPORT JOBS | VOLUME II B | |
| | | SECTION D | |
| | | REV. NO. 0 | DATE 10/08/2010 |
| | | SHEET 49 | OF 52 |

11.4 PACKING FOR DC BATTERY

The packing procedure for seaworthy packing of DC Battery is defined below, which is capable of withstanding impacts, compression, vibration, toppling, sea water spray, prevention against rust, temperature and extreme atmospheric conditions. Aspects of packing specific to equipments / items of DC Battery are given here. All other instructions / aspects as per the main specification of export packing which are not covered here shall also be applicable.

The packing procedure consists of various stages namely primary packing, cushioning, securing, desiccant, outside packing box, Runners/ sliders/ transverse bars of plywood, etc., provided for each movement.

- a) The packing boxes shall be made up of plywood boxes (thickness 9mm min.) with blocks at the bottom of the box for provision for handling the boxes using the forklift. The packing boxes sizes are generally standardized to half-euro size (capable of handling equipment's weight).
- b) Rubberized coir of 25mm thickness shall be provided as cushioning material at the bottom and thermocole of 20mm shall be provided inside on all four sides. Other than this polyethylene film wrap or cover also will be provided. Left out spaces to be filled with rubberized coir/ thermocol to get cushioning effect.
- c) Silica gel in dust free air permeable cotton/paper bag shall be placed in the packing boxes for storage period of 1 year as per IS 304 (1979)
- d) While packing the cells, transit caps (polypropylene) of red and blue shall be used for big size cells for ensuring that cells does not get damaged during the transport due to vibrations etc.
- e) The battery accessories shall be packed with suitable precautions as follows:
 - i) Copper connectors shall be packed after making bunches with lead wire seals to avoid misplacement.
 - ii) Hardware items shall be packed in polyethylene bags (Thickness $\geq 0.175\text{mm}$) with item slip
 - iii) Battery rack shall be packed in dismantled condition, wrapped with polyethylene sheet
 - iv) For Ni-Cd type battery, electrolyte in solid form for dry cells shall be packed in cans with KOH, LiOH being packed separately.
 - f) Galvanized Steel straps are provided for binding the packing box sides.
 - g) The handling instructions shall be marked in indelible/ non-washable ink, indicating the upright position.

11.5 PACKING OF SERVICE TRANSFORMERS(OIL FILLED) & ACCESSORIES

This instruction is applicable for packing of transformers (oil filled), its accessories and components so as to ensure safe delivery to end user. Aspects of packing specific to equipments / items of transformers(oil filled) are given here. All other instructions / aspects as per the main specification of export packing which are not covered here shall also be applicable.

11.5.01 PACKING DETAILS :

- a) Items shall be packed in case / crates as per the shipping list.
- b) All fragile items and small items shall be packed in cases and to be marked as "Fragile, handle with care Fragile items".
- c) Fragile accessories are to be first packed in their original boxes (VENDOR's packing). Very