

FIRST ANGLE PROJECTION

(ALL DIMENSIONS ARE IN mm) FORM DG39(B)

COPYRIGHT AND CONFIDENTIAL  
 THE INFORMATION ON THIS DOCUMENT IS THE PROPERTY OF BHARAT  
 HEAVY ELECTRICALS LIMITED IT MUST NOT BE USED DIRECTLY OR  
 INDIRECTLY IN ANY WAY DETRIMENTAL TO THE INTEREST OF COMPANY

|     |      |                    |     |      |                    |                  |                   |
|-----|------|--------------------|-----|------|--------------------|------------------|-------------------|
| REV | DATE | ALTERED<br>CHECKED | REV | DATE | ALTERED<br>CHECKED | GMSNo./GR.SP.No. | STATUS<br>OF DRG. |
|     |      |                    |     |      |                    |                  |                   |
|     |      |                    |     |      |                    | AGREED<br>DEPT.  | NAME              |
|     |      |                    |     |      |                    | SIGN.            | DATE              |
|     |      |                    |     |      |                    |                  |                   |

GRADE OF UNTOL. DIM.M/CG>C/M/R/-AA0230208 WELDING M/B/C/D AA0621104 GASCUTTING-T3'AA0621101

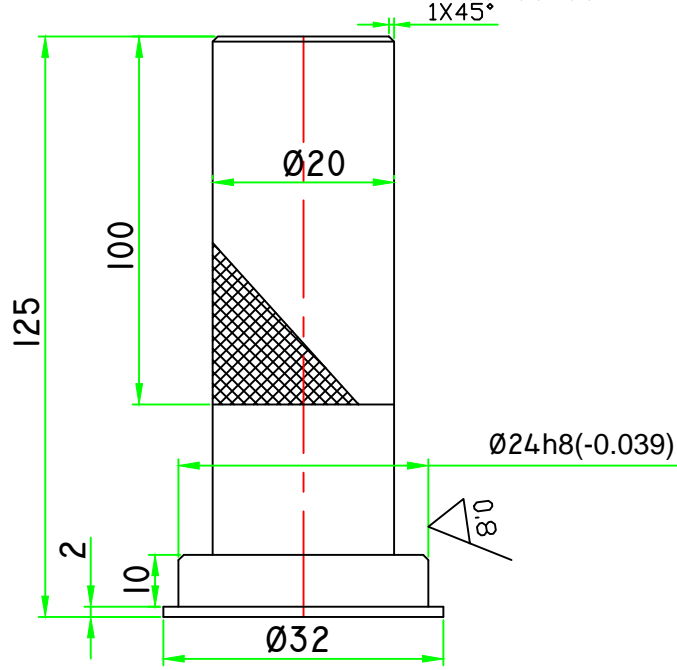

6.3/  
THE REST

1-HARDEN TO HRC 40-45 AS PER INST. NO 0912.008  
 2-SHARP EDGES TO BE ROUNDED OFF.

|                  |  |             |            |                       |                 |        |      |             |
|------------------|--|-------------|------------|-----------------------|-----------------|--------|------|-------------|
| REMARKS          | ITEM No.                                 | DESCRIPTION | STD        | VAR                   | 40Cr1/En24      | A      | UNIT | UNIT WEIGHT |
|                  |  |             |            |                       | HW10571/AA10501 |        |      |             |
|                  |  |             |            |                       | MATERIAL CODE   |        |      |             |
|                  |  |             |            |                       | MATERIAL SPECN  |        |      |             |
| SIGN & DATE      | BHARAT HEAVY ELECTRICALS LTD.<br>HARDWAR | DRN         | V.SINGH    | Sd                    | 16.1.09         | No. OF |      |             |
|                  |  | CHD         | SKB        | Sd                    | 16.1.09         | VAR    |      |             |
|                  |  | APD         |            |                       |                 |        |      |             |
| DEPT             | JTE                                      | SCALE       | WEIGHT(Kg) | REF. TO ASSY. DRG.    | ITEM No.        | No. OF | ITEM |             |
| CODE             | 209                                      | NTS         | -          | <b>R0850-0649</b>     |                 |        |      |             |
| TITLE            |  |             |            | DRAWING No.           | REV             |        |      |             |
| <b>GUIDE PIN</b> |  |             |            | <b>R0850-0649/002</b> |                 |        |      |             |
|                  |  |             |            | SHEET No.             | No. OF SHEETS   |        |      |             |

SIZE A4