

6790-0649
DRAWING No. R0850-0649

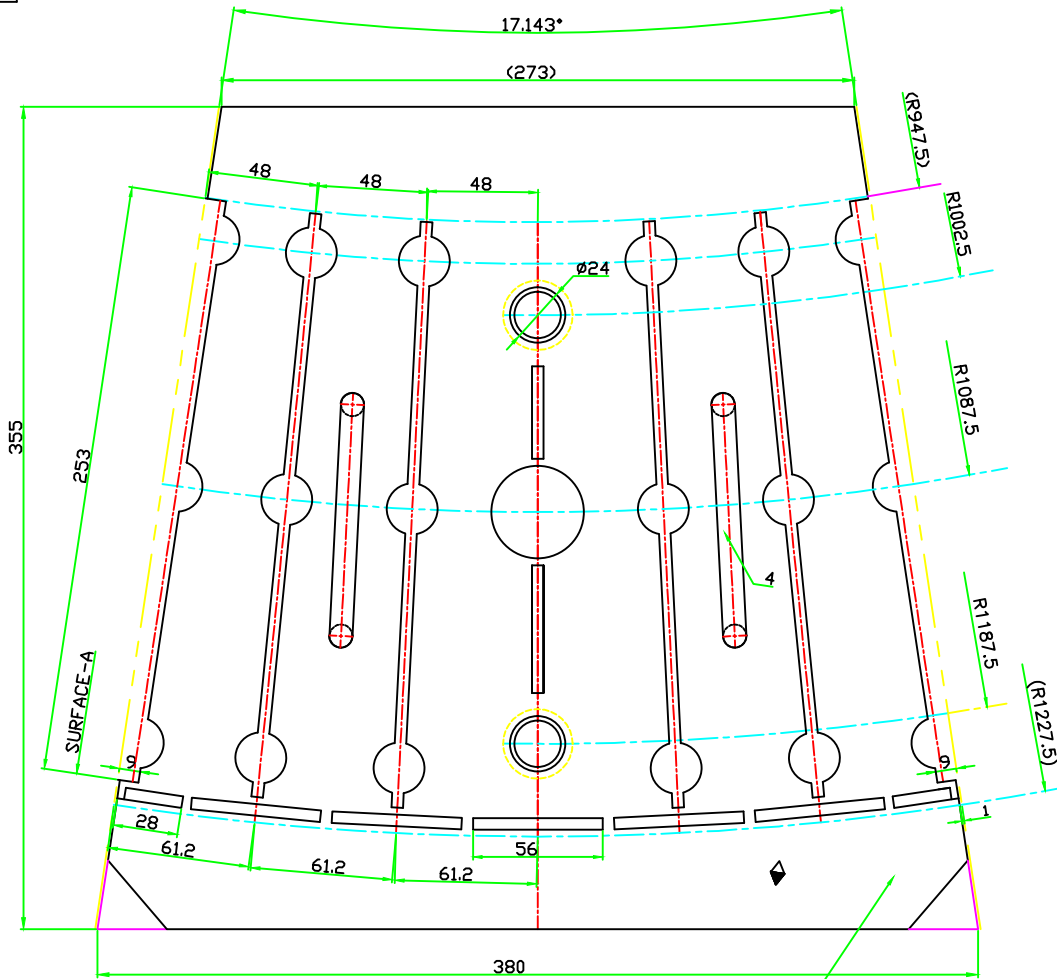

SCHEME FOR VARIANTS

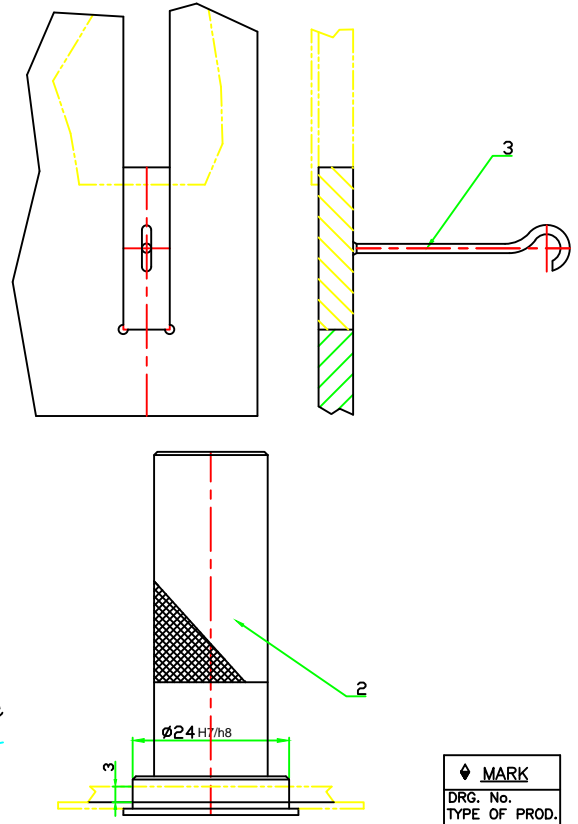

- 1-FOR WELDING OF SPACERS USE SURFACES MARKED 'A' AS REFERENCE
- 2-FIXTURE TO BE ACCEPTED AFTER TRIAL ONLY
- 3-FIXTURE TO BE CONSERVED AS PER TL-30007
- 4-FOR COMP.NO.21352101045,USE SPACER (IT.NO.3)VAR.01 R0850-0649/003
- 5-FOR COMP.NO.21352101047,USE SPACER (IT.NO.3)VAR.02 R0850-0649/004

VAR.00	REMARKS	ITEM No.	DESCRIPTION	STD.	DRAWING No.	MATERIAL CODE	UNIT WEIGHT	QTY.
		4	HANDLE		TL-10043	Fe41 OWA		2
		3	SPACER		R0850-0649/003-004	Al10108 IS2082		ONE EACH
		2	GUIDE PIN		R0850-0649/002	40Cr1/En24		2
		1	TEMPLATE		R0850-0649/001	Al10571/Al10501		3.0

GMS No./GR.SP.No.	STATUS OF DRG.	TYPE OF PRODUCT	COMP. DRG. No.	M/C TOOL TRANS. No.	REF. DRG. No.
		THDF-115/67	21352101043,45,47		R0850-0642
DESIGN ORDER No.			0704PT6TGD0446	MODEL No.	

GRADE OF UNTOL.DIM. :-	M/CG-C/M/E A4023020B	WELDING-A/B/C/D-A40821104	GAS CUTTING-T3/A40821101
DEPT.	JTE	SCALE	NTS
CODE	209	WEIGHT(Kg.)	1.7
TITLE	SPOT WELDING FIXTURE		
ISSUING No.	R0850-0649		
SHEET No.	01	No. OF SHEET	01

COPYRIGHT AND CONFIDENTIAL. THE INFORMATION ON THIS DOCUMENT IS THE PROPERTY OF BHARAT HEAVY ELECTRICALS LIMITED. IT MUST NOT BE USED WITHOUT PERMISSION IN WRITING BY THE PROPERTY OF THE COMPANY.

INVENTORY No. SIGN. & DATE REF. DRG. No.