

FIRST ANGLE PROJECTION

(ALL DIMENSIONS ARE IN mm) FORM DG39(B)

COPYRIGHT AND CONFIDENTIAL

THE INFORMATION ON THIS DOCUMENT IS THE PROPERTY OF BHARAT HEAVY ELECTRICALS LIMITED IT MUST NOT BE USED DIRECTLY OR INDIRECTLY IN ANY WAY DETRIMENTAL TO THE INTEREST OF COMPANY

REV	DATE	ALTERED	REV	DATE	ALTERED	GMSNo./GR.SP.No.		STATUS
		CHECKED			CHECKED			OF DRG.
						AGREED	NAME	SIGN.
						DEPT.		DATE

GRADE OF UNTOL. DIM.M/CG/C/M/X/-AA0230208 WELDING A/B/C/D AA0621104 GASCUTTING-T3'AA0621101

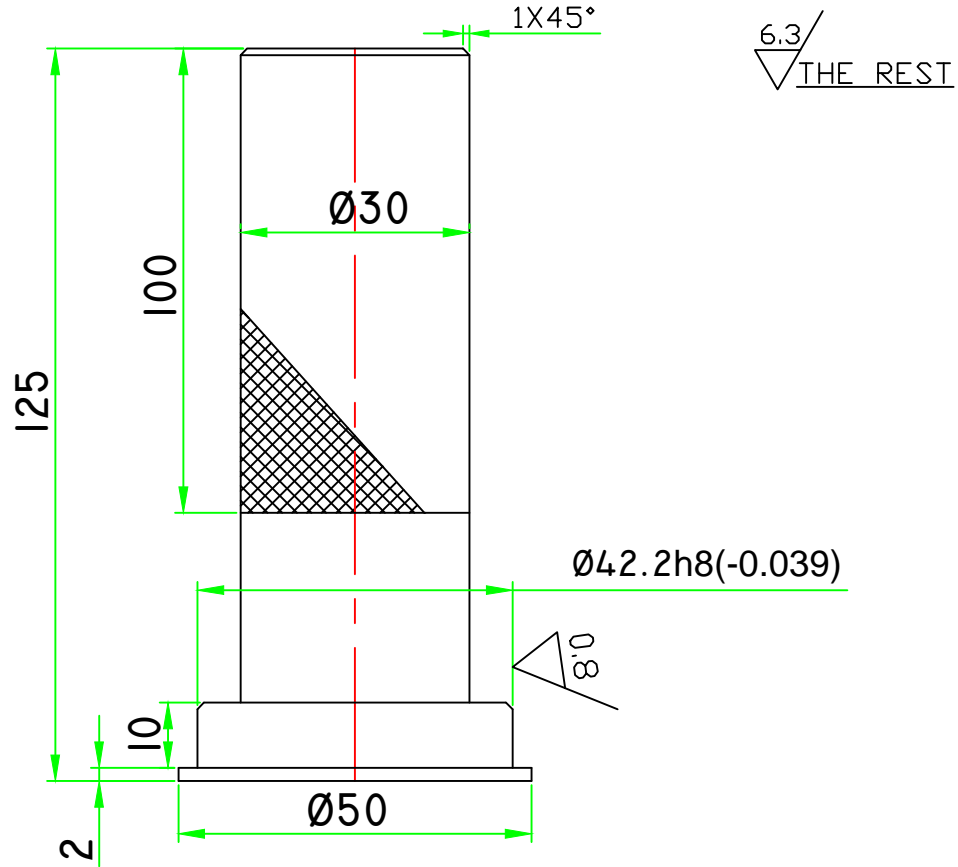

1-HARDEN TO HRC 40-45 AS PER INST. NO 0912.008
2-SHARP EDGES TO BE ROUNDED OFF.

REF.DRG.No.	40Cr1/En24						
	HW10571/AA10501						
REMARKS	ITEM No.	DESCRIPTION	STD	MATERIAL CODE	A	UNIT WEIGHT	
			VAR	MATERIAL SPECN	C		
SIGN & DATE	BHARAT HEAVY ELECTRICALS LTD. HARDWAR		NAME	SIGN	DATE	No. OF VAR	
			DRN	V.SINGH	Sd		24.1.08
			CHD	SKB	Sd		24.1.08
INVENTORY No	DEPT	JTE	SCALE	WEIGHT(Kg)	REF. TO ASSY. DRG.	ITEM No.	No. OF ITEM
	CODE	209	NTS	-	R0850-0650		
	TITLE				DRAWING No.		REV
GUIDE PIN				R0850-0650/002			
SHEET No.			No. OF SHEETS				
SIZE A4							