



ISO 9001:2008  
&14001:2004  
NAVARATNA  
COMPANY

**MATERIAL MANAGEMENT (PURCHASE)  
CENTRAL FOUNDRY FORGE PLANT, BHEL HARDWAR**

RANIPUR, HARIDWAR (INDIA) – 249403

Phone No.+91-1334-281277/284684/284548, FAX No. 225892

e-mail : [ranjank@bhelhwr.co.in](mailto:ranjank@bhelhwr.co.in); [rohit\\_v@bhelhwr.co.in](mailto:rohit_v@bhelhwr.co.in);  
[v\\_kumar@bhelhwr.co.in](mailto:v_kumar@bhelhwr.co.in)

**Sub:** Tender Enquiry No: 5403P/351/5/0063K1 due on 08.06.2015, at 2.00 PM

Dear Sir,

We are pleased to invite offer as per enclosed specifications with terms and conditions in sealed covers for the under mentioned items.

Sl No	Tender No	Description of Material	Qty	Date & Time of Opening
01	5403P/351/5/0063K1	RBMC Bricks	43000 Nos.	08.06.2015 at 2.00 PM

**KINDLY READ TERMS AND CONDITIONS. OFFER NOT IN ACCORDANCE WITH THE INSTRUCTIONS IS LIABLE TO BE DISQUALIFIED OR IGNORED.**

Please visit [www.bhel.com](http://www.bhel.com) or [www.bhelhwr.co.in](http://www.bhelhwr.co.in) for more details and tender documents.

Unregistered vendors should download Vendor Registration Form and submit same duly filled along with offer.

Thanking You,

Yours Faithfully,  
For & On behalf of CFFP, BHEL, Hardwar

(Vipin Kumar)  
Engineer (Purchase)

**Note:** Corrigendum if any shall not be published, kindly refers websites for any changes.



निविदा सूचना  
**TENDER ENQUIRY**

भारत हैवी इलेक्ट्रिकल्स लिमिटेड  
**Bharat Heavy Electricals Ltd**  
सेन्ट्रल फाउन्ड्री फोर्ज प्लांट- हरिद्वार - २४६४०३ (भारत)  
**Central Foundry Forge Plant, Haridwar-249403 (INDIA)**

Phone : (0091) 01334- 281639,281385,285336 Fax : 01334 225892 / 226458 TIN NO. 05001763485  
C S T NO. HR-5018287 Dt. 16-03-1995

निविदा सूचना सं. ENQUIRY NO.★	5403 P/ 351/5/0063K1	दिनांक Date	18-05-2015
-------------------------------	----------------------	-------------	------------

कृपया निम्नलिखित के लिए निविदा दें। PLEASE QUOTE FOR THE FOLLOWING :

M/S. :: DUEDATE **08-06-2015**  
 ::  
 :  
 INDIA Vendor Code **09285**

SL	MATERIAL CODE ITEM DESCRIPTION	QUANTITY	UNIT	LOTNO	LOT DELIVERY QTY SCHEDULE
1	FF2618081030 RESIN BONDED MAGNESIA CARBON BRICKS (RBMS-SPL) -HEAVY DUTY. Spec Rev not available <del>????????????????</del> <i>FF05066, Rev 04</i> SIZE: LADLE BRICKS, DRG OF SU745 DIM.: S	40000	NO		
2	FF2618081064 RESIN BONDED MAGNESIA CARBON B RICKS (RBMC-SPL) HEAVY DUTY, FOR BOTTOM OF VAD LADLES. AS PER CL AUSE 6.2.2 OF SPECIFICATION. SIZE: 225X250X100 MM. Spec Rev not available <del>????????????????</del> <i>FF05066 Rev 04</i> SIZE: SIZE: 225X250X100 MM. DIM.: S	3000	NO		

**\*\* IMPORTANT:** This enquiry is 2 part tender. Techno-Commercial bid (Part-1) & Price Bids (Part-2) should be submitted in separate envelopes. These two envelopes should be submitted in a common sealed envelope. Techno-Commercial Bid shall contain detailed Technical Specification, Drawings Technical documents, Catalogues, taxes & duties, payment terms, delivery period, Validity of offer, Replica of Price Bid (Copy of price bid without price part) etc. The confirmation to the special terms & conditions must be submitted alongwith Techno-Commercial bid.

Standard Instructions:  
 TEST CERTIFICATE REQUIRED.  
 GUARANTEE CERTIFICATE REQUIRED.  
 BASIC RATES, TAXES DUTIES SEPERATELY  
 CENVATABLE DUPLICATE COPY OF INVOICE.  
 INSP AFTER RECPT AT CFFP.

Special Instructions:  
 (A) VALIDITY OF OFFER SHOULD BE MIN 120 DAYS FROM DATE OF OPENING.  
 (B) OFFER MUST BE SUBMITTED STRICTELY IN LINE WITH SPECIFICATION, TERMS & CONDITIONS OF ENQUIRY ELSE OFFER MAY LIKELY BE IGNORED.  
 (C) ALL TAXES/DUTIES/LEVIES ETC. MUST BE SPECIFIED SEPERATELY IN

*V Jain*  
18/05/15

Page No 1

★ महत्वपूर्ण : कृपया कोटेशन देने से पूर्व पीछे दिए गये अनुदेशों को ध्यानपूर्वक पढ़िये।  
**IMPORTANT : PLEASE READ CAREFULLY THE INSTRUCTIONS GIVEN ON REVERSE BEFORE QUOTING**



AA-17001

निविदा सूचना  
**TENDER ENQUIRY**

भारत हेवी इलैक्ट्रिकल्स लिमिटेड  
**Bharat Heavy Electricals Ltd**  
सेन्ट्रल फाउन्ड्री फोर्ज प्लांट- हरिद्वार - २४६४०३ (भारत)  
**Central Foundry Forge Plant, Haridwar-249403 (INDIA)**

Phone : (0091) 01334- 281639,281385,285336 Fax : 01334 225892 / 226458

TIN NO. 05001763485  
C S T NO. HR-5018287 Dt. 16-03-1995

निविदा सूचना सं. ENQUIRY NO.*	5403 P/ 351/5/0063K1	दिनांक Date	13-05-2015
-------------------------------	----------------------	-------------	------------

कृपया निम्नलिखित के लिए निविदा दें। PLEASE QUOTE FOR THE FOLLOWING :

MATERIAL CODE QUANTITY UNIT LOTNO  
ITEM DESCRIPTION

AMOUNT OR IN PERCENTAGE. INCOMPLETE OFFER SHALL NOT BE ACCEPTABLE.

(D) "ANNEXURE-A" DULY FILLED &amp; SIGNED WITH COMPANY SEAL IS TO BE SUBMITTED ALONGWITH OFFER.

(E) DELIVERY :- AS PER ANNEXURE - 'A'

## General Instructions:

1. Please submit authorization letter (format enclosed) for facilitating e-payment/electronic transfer of funds
  2. 100% payment within 30 days after receipt & acceptance of material at CFFP BHEL, Hardwar through e-payment.
  3. CFFP/BHEL RESERVES THE RIGHT TO PRE-INSPECT THE MATERIAL AT VENDOR'S WORKS / GODOWN/ PREMISES BEFORE DESPATCH.
  4. ORIGINAL MANUFACTURER'S TEST CERTIFICATE IS REQUIRED ALONG WITH DESPATCH DOCUMENTS. IN CASE SUPPLIES ARE FROM TRADERS, IT SHALL BE THE RESPONSIBILITY OF THE TRADER TO PROVIDE ORIGINAL MANUFACTURER'S TEST CERTIFICATE WITH LINKAGE TO TRADER'S INVOICE STATING BATCH NO.
  5. CFFP/BHEL Reserves the right to procure from more than one vendor.
  6. Please quote prices in figures & words both. In case the prices quoted in words and figures are different, the values indicated in words will be considered for evaluation & establishing L1 status.
- \* The offers of the bidders who are on the banned list as also the offers of the bidders, who engage the services of the banned firms, shall be rejected. The list of banned firms is available on web site [www.bhel.com](http://www.bhel.com)

*Vipin Kumar*  
18/05/15  
VIPIN KUMAR  
ENGINEER (PUR)

★ महत्वपूर्ण : कृपया कोटेशन देने से पूर्व पीछे दिए गये अनुदेशों को ध्यानपूर्वक पढ़िये।

IMPORTANT : PLEASE READ CAREFULLY THE INSTRUCTIONS GIVEN ON REVERSE BEFORE QUOTING



**PLANT PURCHASE SPECIFICATION**  
(CFFP - HARDWAR)

**FF 05066 Rev04**

Page 1 of 6

**HEAVY DUTY RESIN BONDED MAGNESIA CARBON (RBMC SPL)  
BRICKS FOR EAF AND VAD/VOD /LRF LADLES.**

**1. SCOPE.**

This specification governs the quality requirement of RBMC-Spl bricks for Electric arc furnaces, VAD/ VOD & LRF ladles.

**2. APPLICATION.**

\*Used for working lining of Electric arc furnaces and Side wall & bottom lining of VAD/VOD & LRF Ladles for holding liquid steel.

**3. CONDITION OF DELIVERY.**

The different types of bricks shall be supplied as per sizes & Drawings indicated at PAGE Nos 2 to 5 of this specification.

\* Used to make working lining of:

- 6.1 : Electric arc furnaces of capacity 10T& 30T
- 6.2.1 : Side wall lining of VAD/VOD & LRF ladles.
- 6.2.2 : Bottom bricks of VAD/VOD & LRF ladles.
- 6.3 : Electric arc furnaces of capacity 70T
- 6.4 : Tap hole refractory for EBT of 70T EAF.

**4. COMPLIANCE WITH NATIONAL STANDARDS.**

There is no national specification of resin bonded Magnesia Carbon bricks

**5. PROPERTIES.**

When tested in accordance with the relevant clauses of IS-1528 or Equivalent International Standard, the test sample shall show the following values

**5.1 CHEMICAL COMPOSITION**

Sl.No	Elements	Content	
		% (Min)	%(Max)
a)	MgO (In Magnesia used)	97	-
b)	Residual Carbon (To be determined by British cocking test)	8	12
c)	Al <sub>2</sub> O <sub>3</sub>	-	2.0
d)	CaO	-	2.0
e)	SiO <sub>2</sub>	-	1.5
f)	Fe <sub>2</sub> O <sub>3</sub>	-	0.5

COPYRIGHT AND CONFIDENTIAL  
The information on this documents is the property of Bharat Heavy Electrical Limited. It must not be used directly or indirectly in any way detrimental to the interest of the company

RMI	S.N.GHOSH	<i>[Signature]</i>	WORKED BY	M.K.SAHU
MPIC	N.K.VERMA	<i>[Signature]</i>	CHECKED BY	RANJAN
CHAIRMAN CPSC	R..PARTHASARTHY	<i>[Signature]</i>	SUPERVISED BY	S.V.S NARAYANA
			APPROVED : <b>PLANT STANDARDS COMMITTEE</b>	
			PREPARED : SMS TECH	ISSUED : Steel Melting Shop
			DATE : 20/4/10	



# PLANT PURCHASE SPECIFICATION

FF 05066 Rev04

(CFFP - HARDWAR)

Page 2 of 6

COPYRIGHT AND CONFIDENTIAL

The information on this documents is the property of Bharat Heavy Electrical Limited. It must not be used directly or indirectly in any way detrimental to the interest of the company

## 5.2 PHYSICAL PROPERTIES.

Bulk density (gm/cc)	3 (Min)
A. Porosity	5% (Max)
C.C.S (N/mm <sup>2</sup> )	35 (Min)
Refractoriness under load	1600°C (Min)
Thermal Expansion up to 1400°C	2% (Max)
HMOR, (Kg/cm <sup>2</sup> ) at 1400°C * 30 min	125 (Min)

## 6.0 TYPES OF BRICKS.

	DESCRIPTION	SIZE	a (mm)	b (mm)	h (mm)	l (mm)	r (mm)	A (deg)
6.1	Bricks for lining of 30T and 10T EAF	30/20	160	140	300	100	2100	-
		30/40	170	130	300	100	975	-
6.2.1	Bricks for side wall lining of ladles.	SU 745	210	185.2	100	177.8	-	8
6.2.2	VAD/VOD/LRF Ladles	Bottom bricks for ladles	225	250	100	-	-	-

Drawing of Bricks given at PAGE NO 4

## 6.3 BRICKS FOR LINING OF 70T EAF.

QUANTITY INDICATED BELOW IS FOR ONE SET OF LINING.

SL NO	BRICKS SIZE	QUANTITY
1	400*190/110*100mm	68 nos
2	400*170/130*100mm	399 nos
3	400*160/140*100 mm	360 nos
4	350*170/130*100 mm	24 nos
5	350*160/140*100 mm	342 nos
6	400*150/100mm	402 nos
7	350*150/100mm	128 nos

(Dimensional tolerances:  $\pm 1.5\%$  or 2mm which ever is greater.)

WORKED BY

M.K.SAHU

20/4/10

CHECKED BY

RANJAN

20/4/10



# PLANT PURCHASE SPECIFICATION

(CFFP - HARDWAR)

FF 05066 Rev04

Page 3 of 6

COPYRIGHT AND CONFIDENTIAL  
The information on this documents is the property of Bharat Heavy Electrical Limited. It must not be used directly or indirectly in any way detrimental to the interest of the company

## 6.4 TAP HOLE REFRACTORIES FOR 70T EAF

Sizes and set as per drawing given at PAGE NO 5.

## 7. INSPECTION

- CFFP reserves the right to witness the testing of the material at supplier works and therefore the supplier shall notify the readiness of the material in advance.
- CFFP may, at its discretion, test the material after receipt and acceptance of the material will be based on the CFFP'S test results.
- For result of analysis and properties of material the decision of CFFP shall be final and binding on the supplier.

## 8. TEST CERTIFICATES

One Original and three copies of Test Certificate from the Manufacturer containing the following information along with the test result of all the properties given in the clause no 5 should be provided. The T.C. should contain the packing details of the materials.

Manufacturer's Name

Name of the material

Batch/Lot No.

Quantity.

## 9. PACKING AND MARKING

Packing should be such as to prevent loss / deterioration in quality during handling, transport and storage. It should be in the Manufacturer's packing. Each package should be marked with the following details.

Name of the material

Manufacturer's Name / Trade mark

Batch/Lot No.

Net weight.

WORKED  
BY

M.K.SAHU

20/4/10

CHECKED  
BY

RANJAN

20/4/10



# PLANT PURCHASE SPECIFICATION

FF 05066 Rev04

(CFFP - HARDWAR)

Page 4 of 6

COPYRIGHT AND CONFIDENTIAL

The information on this document is the property of Bharat Heavy Electrical Limited. It must not be used, directly or indirectly, in any way detrimental to the interest of the company.

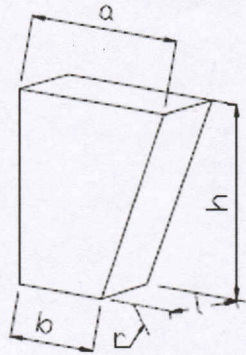

SIZE: 30/20 & 30/40

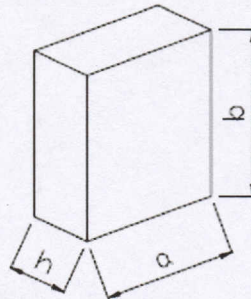

BOTTOM BRICK

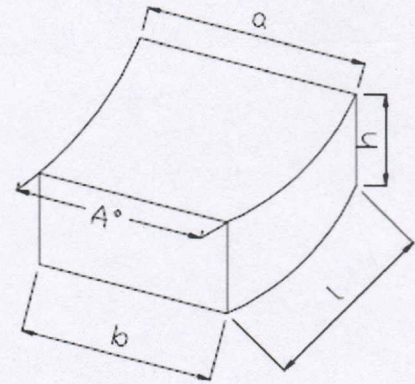

SIZE: SU 745

WORKED BY

M.K.SAHU

*M.K. Sahu* 20/4/10

CHECKED BY

RANJAN

*Ranjan* 20/4/10



# PLANT PURCHASE SPECIFICATION

(CFPP - HARDWAR)

FF 05066 Rev04

Page 5 of 6

**COPYRIGHT AND CONFIDENTIAL**  
The information on this documents is the property of Bharat Heavy Electrical Limited. It must not be used directly or indirectly in any way detrimental to the interest of the company.

## ASSEMBLY

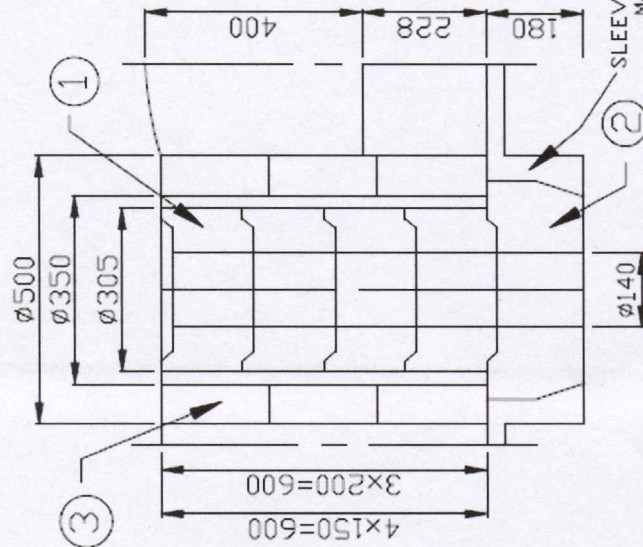

③ TAP BLOCK  
Wt/Piece: 92Kgs

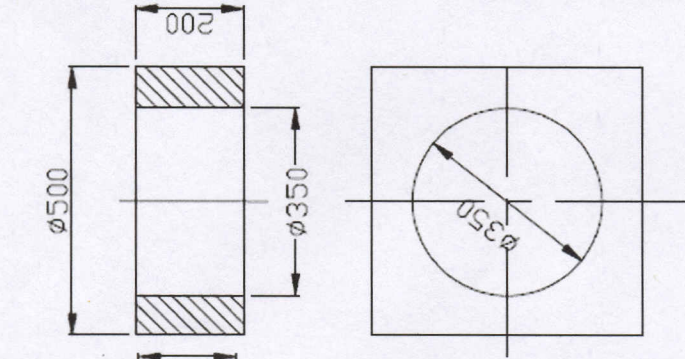

② END BRICK  
Wt/Piece: 55Kgs

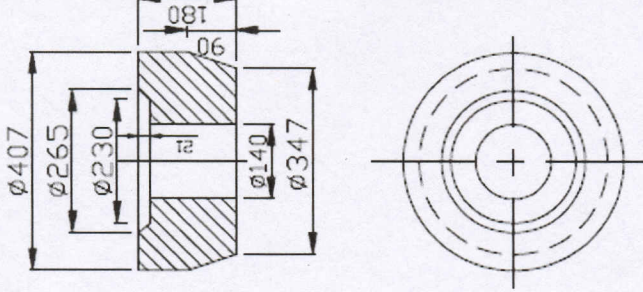

① TAP TUBE  
Wt/Piece: 26Kgs

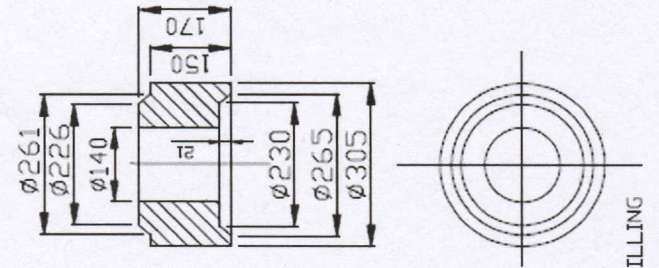

### NOTES:-

- ONE SET CONSISTS OF 4 NOS. OF ITEM 1, 1 NO. OF ITEM 2, 3 NOS. OF ITEM 3

WORKED BY

M.K.SAHU

*M.K. Sahu* 20/4/10

CHECKED BY

RANJAN

*Ranjan* 20/4/10



# PLANT PURCHASE SPECIFICATION

(CFFP - HARDWAR)

FF 05066 Rev04

Page 6 of 6

## REVISION RECORD SHEET

SN	Revision No.	Revision date	Nature of Changes
01.	03	17.07.2006	-Packing clause modified.
02.	04	20.04.2010	<p>1- Clause no 5 modified. MgO % changed from 94.5% min to 97% min and this is in used Magnesia. Residual carbon % changed to 8-12% from max of 12%. Al<sub>2</sub>O<sub>3</sub> Content changed to 2.0% max from 0.65% max. Fe<sub>2</sub>O<sub>3</sub> content limited to 0.5%.</p> <p>2- DBCM spl bricks removed from spec. Tap hole refractory for 70T EAF incorporated in the specification. SU 645 size removed.</p> <p>3- Clause no 7: Inspection by third party agency included.</p> <p>4- Clause no 8: All the properties mentioned at clause no 5 are to be given in T.C. The T.C. should contain the packing details of material.</p>

COPYRIGHT AND CONFIDENTIAL

The information on this documents is the property of Bharat Heavy Electrical Limited. It must not be used directly or indirectly in any way detrimental to the interest of the company

WORKED BY

M.K.SAHU

20/4/10

CHECKED BY

RANJAN

20/4/10

Name of Vendor:.....

Confirmation/comments on the conditions given below are mandatory. Please confirm the following or else your offer is liable to be rejected.

	Description	Vendor Confirmation /Comment (In case of blank, it shall be deemed to be accepted by vendor)
1	<p><b><u>Pre- Qualification Requirement for SU 745:</u></b></p> <p>(1) Purchase Order will be placed only on the Manufacturer.  (2) Participating Vendor has to be either Manufacturer or Manufacturer's Agent. (Agreement between agent and manufacturer need to be provided.)  (3) Original manufacturer must have manufactured and supplied at least 40000 Nos. of Magnesia carbon bricks in Semi Universal shape of SU-645 to SU-945 in one financial year within last five years.  (4) In support of Point (3) vendor has to provide copy of Purchase Order/ Invoice placed on the manufacturer for supply of Magnesia carbon bricks in Semi Universal shape of SU-645 to SU-945 in one financial year within last five years from date of Tender Enquiry.  (5) Performance Certificate of the Manufacturer by their customer to whom Semi Universal Bricks were supplied, has to be provided.</p> <p><b>Note: Vendors registered at CFFP for this item are exempted from Pre- Qualification Requirement.</b></p> <p><b><u>Pre-Qualification Requirement for RBMC Bottom Bricks:</u></b></p> <p>(1) Purchase Order will be placed only on the Manufacturer.  (2) Participating Vendor has to be either Manufacturer or Manufacturer's Agent. (Agreement between agent and manufacturer need to be provided.)  (3) Original manufacturer must have manufactured and supplied at least 3000 Nos. of Magnesia carbon bottom bricks for ladles in one financial year within last five years.  (4) In support of Point (3) vendor has to provide copy of Purchase Order/ Invoice placed on the manufacturer for supply of Magnesia carbon bottom bricks for ladles in one financial year within last five years from date of Tender Enquiry.  (5) Performance Certificate of the Manufacturer by their customer to whom Bottom bricks were supplied, has to be provided.</p> <p><b>Note: Vendors registered at CFFP for this item are exempted from Pre- Qualification Requirement.</b></p>	
2	Guarantee Certificate (as per specification/enquiry) shall be provided along with despatch documents.	
3	Please specify whether you are a manufacturer or a manufacturer's agent of this material	
4	Original Manufacturer's Test Certificate shall be provided along with despatch documents.	
5	Final inspection shall be carried out after receipt of material at CFFP. However, CFFP reserves the right to pre Inspect the material at supplier works.	

6	<p>Delivery shall be made on FOR Destination basis, destination being Stores/CFFP/BHEL Haridwar, Freight &amp; Insurance charges to vendor's account. From foreign vendors (on whom order is placed) the delivery preferred is on DDP / DAP basis, However Delivery on FOB basis is also acceptable.</p>	
7	<p>BHEL reserves the right to go for Reverse Auction (RA) instead of opening the sealed envelope price bid submitted by the bidder. This will be decided after techno-commercial evaluation. All bidders to give their acceptance for participation in RA. Non-acceptance to participate in RA may result in non-consideration of their bids, in case BHEL decides to go for RA.</p> <p>In case BHEL decides to go for Reverse Auction, only those bidders who have given their acceptance to participate in RA will be allowed to participate in the Reverse Auction. Those bidders who have given their acceptance to participate in Reverse Auction will have to necessarily submit online sealed bid in the Reverse Auction. Non-submission of online sealed bid by the bidder will be considered as tampering of the tender process and will invite action by BHEL as per extant guidelines in vogue.</p> <p>In case BHEL decides to go for reverse auction, the H1 bidder(s) (whose quote is highest in Online Sealed bid) may not be allowed to participate in further RA process.</p>	
8	<p><b>Payment Term:</b>  For indigenous suppliers: 100% within 30 days after receipt &amp; acceptance of material at CFFP / BHEL, Haridwar through e-payment.  For foreign suppliers: Payment through USANCE LC on 70<sup>th</sup> day of bill of lading date. All bank charges shall be to vendor's account.</p> <p>* In case vendor does not agree, proper loading shall be done. Base rate of SBI (as applicable on the date of bid opening: Techno commercial bid opening in case of two part bids) + 6%, shall be considered for loading for the period of relaxation sought by bidders.</p> <p>Also in that case, third party inspection shall have to be arranged by supplier from any of the five inspection agencies namely: LRS/ BVQI/ DNV/ TUV-SUD / Alfred H Knight at their cost.</p>	
9	<p>Validity of offer: Minimum 120 days from tender opening date. Offers with validity less than 120 days may not be considered.</p>	
10	<p>Delivery schedule for FOR Destination / DDP / DAP basis (DDP / DAP for foreign vendors only on whom order is placed) is as under:  75 days from PO date</p> <p>The delivery schedule in case of FOB shall be: BOL date should be within 30 days of PO date</p>	
11	<p>Prices shall be firm till execution of Order</p>	
12	<p>CFFP/BHEL reserves the right to order part quantity.</p>	
13	<p><b>Currency of offer:</b> Indian Vendors to quote their price only in INR.  Foreign vendors to quote their price in USD/ EURO/ UK POUND STERLING/ JAPANESE YEN only.  For evaluation of price bids, exchange rate (TT selling rate of SBI) as on scheduled date of tender opening (Part-1 bid in case of two part bid) shall be considered.</p>	
14	<p>Liquidated damage : The delivery of the goods shall be made strictly as per time limit specified in delivery schedule of purchase order, failure to supply within this period will make the supplier liable to penalty of 1/2 (half) percent of the price of the goods in arrears per week subject to a maximum of 10%.</p>	
15	<p>Provide name, mobile no. &amp; email address of the contact person</p>	

16	In case vendor is not registered with CFFP BHEL Haridwar for this material, duly filled up "Supplier Registration Form" must be submitted with techno-commercial bid (form available on website <a href="http://www.bhelhwr.co.in">www.bhelhwr.co.in</a> & <a href="http://www.bhel.com">www.bhel.com</a> ). If duly filled SRF is not received within 15 days of opening of techno commercial bid, offer may not be considered for price bid opening.	
17	Risk Purchase: In case of delayed/defective supplies or non fulfillment of any other terms & conditions given in the Purchase Order, the purchaser may cancel the purchase order in full or part thereof and may also make the purchase of such material at the risk & cost of supplier.	
18	In case of any difference observed in conditions confirmed above & elsewhere in the offer, terms quoted above shall be treated as final and binding on vendor.	

Note: Evaluation for L1 status shall be done on the basis of "Landed cost net of Cenvat at CFFP".

Date:

Signature with Seal of the Company

The scope of third party inspection shall be as under:

1. The inspection is to be carried out as per the ordered specification ensuring original manufacturer's packing, Original manufacturer test certificates etc as per specification and the linkage.
2. The material should be identified as per the specification like original manufacturer's name, Batch/lot no, Net weight, material name. The material should be packed as per specification and sealed by the inspection agency. The seal details should be mentioned in the third party inspection report.
3. The test certificate should contain the complete witnessing of the chemical analysis of material as per IS1472 for nos of test required in a lot and their testing methodology for evaluating nos of element required by the material specification, size verification as per P.O. Specification, purchase order no, Batch/lot no of material, seal details of the inspector along with corresponding packing (packing list).

The scope of third party inspection shall be as under:

1. The inspection is to be carried out as per the ordered specification ensuring original manufacturer's packing, Original manufacturer test certificates etc as per specification and the linkage.
2. The material should be identified as per the specification like original manufacturer's name, Batch/lot no, Net weight, material name. The material should be packed as per specification and sealed by the inspection agency. The seal details should be mentioned in the third party inspection report.
3. The test certificate should contain the complete witnessing of the chemical analysis of material as per IS1472 for nos of test required in a lot and their testing methodology for evaluating nos of element required by the material specification, size verification as per P.O. Specification, purchase order no, Batch/lot no of material, seal details of the inspector along with corresponding packing (packing list).

GENERAL TERMS AND CONDITIONS OF TENDER ENQUIRY  
ANNEXURE-B

01 Submit the tender in two parts i.e.

**Part-I Techno-Commercial Bid**

**Part-II Price Bid**

Techo - Commercial (part one) Price Bid (part two) should be put in separate sealed envelopes. Both envelopes should be super scribed with **Tender Number, Date of opening & Technical / Commercial Bid and Price Bid** respectively along with name of firm.

Both the envelopes i.e. containing Techno-Commercial Bid and Price Bid should again be kept in one envelope super scribed again with Tender No. and Date of opening and the name of firm submitting the tender and send it to **AGM (MM), Purchase Department, CFFP/BHEL, Hardwar, Ranipur, Hardwar 249403, Uttarakhand, India before due date / tender opening date & time**. Normally tender opening time is 2.00 PM on due date or as mentioned in enquiry.

**Responsibility for submission of tender in time solely lies with vendor. Late offers received after specified time / Date shall not be considered.**

1. Part-I Envelopes super scribed with **Techno-Commercial Bid** must contain all information especially-
  - (a) Specification of the material offered should be strictly as per CFFP/BHEL specifications of enquired material in tender documents **Deviations if any must be indicated clearly in the offer. Rates to be quoted on For Destination Basis.**
  - (b) All commercial terms i.e. packing, forwarding Custom duty, Additional Duty, ST/STT/VAT/CST, Excise Duty/CVD. Bank charges, payment terms & insurance etc as applicable (**except price**) should be clearly mentioned in Techno-Commercial bid. Also mention present rate of applicable taxes & duties even if inclusive in rates along with the concessional forms required if any.
  - (c) Confirm to submit all required commercial documents (tax invoice centvatable duplicate copy of invoice, packing list, transit sale agreement etc.) & technical documents (TC/GC/QP etc).
  - (d) Registration Numbers of SSI, Central Excise, Sales tax, Income Tax, DGS & D.ECC etc.
  - (e) **Un-priced copy of Price Bid.**

Part-II Envelopes super scribed with Price Bid should contain priced copy of Price Bid. The price should be mentioned both in figures and words.

2. Authorized Signatory should authenticate all tender documents.
3. **Techno-commercial bid (Part-I)** will be opened on the due date at 2.00 PM in the presence of participating vendors or authorized representatives, who may wish to be present. Representative deputed to witness tender opening must produce an authority letter from the signatory of offer. After evaluation of technical bids & finalization of technical, commercial terms & conditions, price bid of only successful vendors will be opened. Priced bid opening date shall be intimated separately.
4. The material offered must conform to the required BHEL specifications and drawings as well as instructions and details made available.
5. For new vendors, Vendor Registration from duly filled must be submitted along with the offer which can be downloaded from our web site [www.bhel.com](http://www.bhel.com) or [www.bhelhwr.co.in](http://www.bhelhwr.co.in).
6. Original manufacturer's Test Certificate is required along with dispatch documents. In case supplies are from traders, it shall be the responsibility of the trader to provide original manufacture's test certificate with linkage to traders invoice stating batch no.
7. **Validity** of offers should be minimum 90 working days from the date of tender (Techno-Commercial Bid) opening.

8. **Delivery** in the promised period is the essence of contract. Confirm to supply according to delivery schedule mentioned.
9. **Payment terms:**  
For indigenous suppliers: 100% within 30 days after receipt & acceptance of material at CFFP / BHEL, Haridwar through e-payment.  
For foreign suppliers: Payment through USANCE LC on 70<sup>th</sup> day of bill of lading date. All bank charges shall be to vendor's account.  
  
\* In case vendor does not agree, proper loading shall be done. Also in that case, third party inspection shall have to be arranged by supplier from any of the five inspection agencies namely: LRS/ BVQI/ DNV/ TUV/ Alfred H Knight at their cost.
10. CFFP/BHEL, Hardwar reserves the right to accept or reject any or all tenders without assigning any reason thereof.
11. Tenders not submitted in the prescribed manner are likely to be ignored / rejected.
12. Agent/Agency Commissioning: Payment of any kind at any stage will not be made to agent on account of agent commission or otherwise by CFFP/BHEL, Hardwar.
13. CFFP/BHEL, Hardwar may opt for E-auction/Reverse auction for obtaining best prices for part or full tendered quantity. BHEL also reserve the right to negotiate price with L1 vendor after reverse auction.
14. Please do intimate the personal contact details like Name, Mobile Number, Email-id etc of authorized executive for correspondence.
15. **Penalty:** Orders placed against this enquiry will be subject to normal clauses for imposing penalty. Liquidated Damages, Risk purchases, cancellation, arbitration as per terms and conditions of Tender Enquiry and Purchase orders in case of delay in effecting supply and/ or other defaults.  
**Liquidated damage:** The delivery of the goods shall be made strictly as per time limit specified in delivery schedule, failure to supply within this period will make the supplier liable to an conditional penalty of 1/2 (half) percent of the price of the goods in arrears per week subject to a maximum of 10%.
16. **Inspection:** Final inspection of material shall be done after receipt of material at CFFP/BHEL, Hardwar. Acceptance of material shall be after final inspection and shall be binding. However, CFFP reserves the right to pre Inspect the material at supplier works. In case material is found defective during warranty period, the same will be returned for repair and/ or replacement. For this vendor has to bear all the charges such as Freight, to and fro insurance etc. Bank Guarantee for the equal amount to the cost of the item is to be furnished by vendor. In case the repair is done at CFFP/BHEL the amount on actual shall have to be reimbursed by the Vendor and or adjusted on actual from their bill.
17. **Currency of Payment:** Mention the currency in which payment has to be made. For evaluation of price bids, exchange rate (TT selling rate of SBI) as on scheduled date of tender opening (Part-1 bid in case of two part bid) shall be considered.
18. Traders should submit authorization letter from their principal alongwith offer.
19. Disputes: In event of any dispute arising out of contractual obligation, the order being finalized at Hardwar, India will be subject to Indian Laws and falls under jurisdiction of the court of Law at Haridwar, India. The overseas supplier hereafter referred to as "Vendor" shall therefore abide by the verdict of Court of Law at Hardwar, India.  
OR  
All disputes arising out of or in connection with the present contract, if any shall be finally settled under the rules of arbitration of International chamber of commerce by one or more arbitrator appointed in accordance with the said Rules in India.
20. BHEL reserves the right to place P.O. for part / full qty and on one or more than one sources.
21. Any Term & condition of the specific tender (if specified in tender & contradicts with above term) will supersede the above general terms & conditions.

**Terms and conditions regarding Indian agent of foreign suppliers:**

01. BHEL shall deal directly with foreign vendors, wherever required, for procurement of goods. However, if the foreign principal desires to avail of the services of an Indian agent, then the foreign principal should ensure compliance to regulatory guidelines- which require mandatory submission of an Agency agreement.
02. It shall be incumbent on the Indian agent and the foreign principal to adhere to the relevant guidelines of Government of India, issued from time to time.
03. The agency agreement should specify the precise relationship between the foreign OEM/Foreign principal and their Indian agent and their mutual interest in the business. All services to be rendered by agent/associate, whether of general nature or in relation to the particular contract, must be clearly stated by the foreign supplier / Indian agent. Any payment, which the agent or associate receives in India or aboard from the OEM, whether as commission or as a general retainer fee should be brought on record in the agreement and be made explicit in order to ensure compliance to laws of the country.
04. Any agency commission to be paid by BHEL to the Indian agent shall be in Indian currency only.
05. Tax deduction at source is applicable to the agency commission paid to the Indian agent as per the prevailing rules.
06. In the absence of any agency agreement, BHEL shall not deal with any Indian agent (authorized representatives/ associate/consultant, or by whatever name called) and shall deal directly with the foreign principal only for all correspondence and business purposes.
07. The "Guidelines for Indian Agents of Foreign Suppliers" enclosed at annexure- 'A' shall apply in all such cases.
08. The supply and execution of the Purchase Order (including indigenous suppliers/service) shall be in the scope of the OEM/ Foreign principal. The OEM/ Foreign principal should submit their offer inclusive of all indigenous suppliers/services and evaluation will be based on 'total cost to BHEL'. In case OEM/ foreign principal recommends placement of order(s) towards indigenous portion of supplies/services on Indian Supplier (s)/ agent on their behalf, the credentials/capacity/capability of the Indian Supplier (s)/ agent to make the supplies/Services shall be checked by BHEL as per the extant guidelines of Supplier Evaluation, Approval and Review Procedure (SEARP), before opening of price bids. In this regards, details may be checked as per Annexure- 'B' (copy enclosed). It will be the responsibility of the OEM/ Foreign Principal to get acquainted with the evaluation requirements of Indian supplier/agent as per SEARP available on [www.bhel.com](http://www.bhel.com).

The responsibility for successful execution of the contract (including indigenous supplies/services) lies with the OEM/ foreign principal. All bank guarantees to this effect shall be in the scope of the OEM/Foreign principal.

**Guidelines for Indian Agents of Foreign Suppliers**

- 1.0 There shall be compulsory registration of agents for all Global (Open) Tender and Limited Tender. An agent who is not registered with BHEL shall apply for registration in the registration form in line with SEARP.
- 1.1 Registered agents will file an authenticated Photostat copy duly attested by a Notary Public/Original certificate of the Principal confirming the agency agreement and giving the status being enjoyed by the agent and the commission/ remuneration/ salary/ retainership being paid by the principal to the agent before the placement of order by BHEL.
- 1.2 Wherever the Indian representatives have communicated on behalf of their principals and the foreign parties have stated that they are not paying any commission to the Indian agents, and the Indian representative is working on the basis of salary or as retainer, a written declaration to this effect should be submitted by the party (i.e. Principal) before finalizing the order.
- 2.0 **Disclosure of particulars of agents/ representatives in India, if any.**
- 2.1 Tenderers of Foreign nationality shall furnish the following details in their offers:
  - 2.1.1 The Bidder(s)/ Contractor(s) of foreign origin shall disclose the name and address of the agents/ representatives in India if any and the extent of authorization and authority given to commit the Principals. In case the agent/ representative be a foreign Company, it shall be confirmed whether it is existing Company and details of the same shall be furnished.
  - 2.1.2 The amount of commission/ remuneration included in the quoted price(s) for such agents/ representatives in India.
  - 2.1.3 Confirmation of the Tenderer that the commission/ remuneration, if any, payable to his agents/ representatives in India, may be paid by BHEL in Indian Rupees only.
- 2.2 Tenderers of Indian Nationality shall furnish the following details in their offers:
  - 2.2.1 The Bidder(s)/ Contractor(s) of Indian Nationality shall furnish the name and address of the foreign principals, if any, indicating their nationality as well as their status, i.e. whether manufacturer or agents of manufacturer holding the Letter of Authority of the Principal specifically authorizing the agent to make an offer in India in response to tender either directly or through the agents/ representatives.
  - 2.2.2 The amount of commission/ remuneration included in the price (s) quoted by the Tenderer for himself.
  - 2.2.3 Confirmation of the foreign principals of the Tenderer that the commission/ remuneration, if any, reserved for the Tenderer in the quoted price(s), may be paid by BHEL in India in equivalent Indian Rupees on satisfactory completion of the Project or supplies of Stores and Spares in case of operation items.
- 2.3 In either case, in the event of contract materializing, the terms of payment will provide for payment of the commission/ remuneration, if any payable to the agents/ representatives in India in Indian Rupees on expiry of 90 days after the discharge of the obligations under the contract.
- 2.4 Failure to furnish correct and detailed information as called for in paragraph 2.0 above will render the concerned tender liable to rejection or in the event of a contract materializing, the same liable to termination by BHEL. Besides this there would be a penalty of banning business dealings with BHEL or damage or payment of a named sum.

---X---

## Annexure-B

This format is applicable only to Indian Suppliers/ Agents supplying indigenous portion of Foreign Purchases.

\* In all other cases, extant guidelines of SEARP, 2010 are to be followed.

SEARP (SRF) Clause No	Detail
	<b>Name &amp; address of the firm</b>
<b>1.0</b>	<b>Products/ Systems / Services being considered for</b>
<b>2.0</b>	<b>General Information</b>
2.2	Name of Chief Executive
2.3	Details of authorized signatory
<b>3.0</b>	<b>Ownership Information</b>
3.1	Type of firm
3.2	Nature of Business <ul style="list-style-type: none"> <li>• Attach <b>authorization letter</b> and <b>agency agreement</b> from Principal ( from whom capital equipment is procured)</li> <li>• Attach copy of declaration from Foreign Principal for <b>total guarantee/ warranty of indigenous supplies</b></li> </ul>
3.3	Year of establishment
3.4	Year of commencement of business
<b>4.0</b>	<b>Registration particulars</b>
4.1	Permanent Account No.
4.2 / 4.3	Sales Tax / TIN no
4.6	Service tax no. (in case of E&C)
<b>5.0</b>	<b>Organisational strength</b>
<b>6.0</b>	<b>Other particulars</b>
6.1	If the company is already registered with other units
6.2	Directors/ Partners, if related to any BHEL Employee
6.9	If any Ex BHEL Personnel employed by the Company
6.12	Details of pending legal issues with BHEL
6.13	Bank Account information
<b>9.0</b>	<b>Financial information</b>
9.6	Sales/ Turnover details of last 3 years (or from the date of incorporation whichever is less )

---X---